

# ***Puductor Robot***

User manual V1.0

PT1



PuduTech

Copyright © 2020 Pudu Technology Inc. All Rights Reserved.

# Legal information

## User manual

Copyright © 2020 Pudu Technology Inc.

### ALL RIGHTS RESERVED.

Without the express written permission of Pudu Technology Inc., no unit or individual may imitate, reproduce, copy or translate the contents of this manual in part or in whole, the dissemination by any means (electronic, photocopying, recording, etc.) shall not be carried out for the purpose of making profits. Product specifications and information mentioned in this manual are for reference only and are subject to change without notice. Unless otherwise specified, this manual is for guidance only and does not constitute a warranty of any kind.

### Declaration

This device complies with part 15 of the FCC Rules. Operation is subject to the condition that this device does not cause harmful interference (1) this device may not cause harmful interference, and (2) this device must accept any interference received, including interference that may cause undesired operation.

Any changes or modifications not expressly approved by the party responsible for compliance could void the user's authority to operate the equipment.

NOTE: This equipment has been tested and found to comply with the limits for a Class B digital device, pursuant to Part 15 of the FCC Rules. These limits are designed to provide reasonable protection against harmful interference in a residential installation. This equipment generates, uses and can radiate radio frequency energy and, if not installed and used in accordance with the instructions, may cause harmful interference to radio communications. However, there is no guarantee that interference will not occur in a particular installation.

If this equipment does cause harmful interference to radio or television reception, which can be determined by turning the equipment off and on, the user is encouraged to try to correct the interference by one or more of the following measures:

- Reorient or relocate the receiving antenna.
- Increase the separation between the equipment and receiver.
- Connect the equipment into an outlet on a circuit different from that to which the receiver is connected.
- Consult the dealer or an experienced radio/TV technician for help.

To maintain compliance with FCC' s RF Exposure guidelines, This equipment should be installed and operated with minimum distance between 20cm the radiator your body: Use only the supplied antenna.

FCC ID: 2AXDW-PT1

# CATALOG

## Safety Instructions

Instructions for use	4
Environmental notes	5-7
Power and power requirements	8
Safety instructions	9-10

## Product Composition

Component description	11
Performance parameters	12
Introduction to disinfection component	13-14

## Product Use

Charging instructions	15
Charging interface	15
Power ON, Power OFF, Pause, Start	16-17
Disinfection mode	18-19
Alarm display	20

## Service functions

Map settings	21
Voice settings	21
Speed settings	22
Version upgrade	22
Advanced settings	22
Parking instructions	23

## Product Maintenance

Disinfection component, drive wheel and auxiliary wheel	24
Sensors	24
Robot body maintenance	24
Handling of robot	24
Sign maintenance	25

## Troubleshooting

## After-sales Service

# Safety Instruction

## Instructions for use

1. DO NOT block the port of disinfectant spray, and DO NOT put anything into the port.
2. DO NOT drag the robot during the disinfection task, if necessary, tap the screen, and then push it after the pause, the disinfection mode pauses for 20s, and the robot will automatically resume moving after the pause.
3. DO NOT press hard on the screen or tap the screen.
4. DO NOT push the robot backwards while the robot is powered on
5. If the robot enters the wrong position due to factors such as blockage, please pause the task and push it to the correct route to continue the task.
6. In the event of a collision, please cancel the current task or pause, re-enter the task, DO NOT artificially block the robot.
7. The top camera is used for precise positioning of the robot, DO NOT block it with a cover during starting and running.
8. DO NOT tap or make other actions to the robot, otherwise it may easily cause equipment damage.
9. During a disinfection task, the atomized disinfectant may be harmful to the human body, therefore, during the operation of the robot, it is necessary to wear protective equipment such as masks and goggles.

### Environmental notes

1. The robot is suitable for use in flat environments such as floors, tiles, and thin carpets, it is not suitable for use in environments where there are steps, the slope is too large, or the environment is too tight.
2. It is not recommended to use the robot on wet or obviously watery ground.
3. Any kind of debris such as the power cord that has been scattered on the ground may catch or wrap the robot, be sure to remove it before use.
4. The use of this product in the case of obvious protrusions such as sills may cause the disinfectant to sprinkle, please make sure that the height of the protrusions is within 5mm.
5. Minimum traffic width is 0.80m; if the long passage needs to be wider than 1m, the moving fluency is the best; the width greater than 2 meters can meet bidirectional moving.

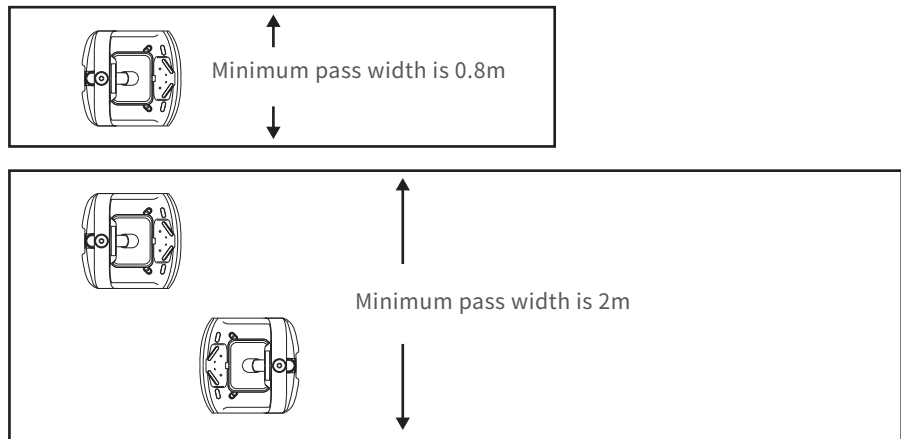

6. The pure black (such as skirting), mirror surface (such as wall), or full transparency (such as floor-to-ceiling glass) items within 10cm from the ground, it may interfere with the robot radar reflection, causing the robot to move abnormally, and it may be necessary to make some modifications to the site so that the radar can reflect (such as applying stickers).

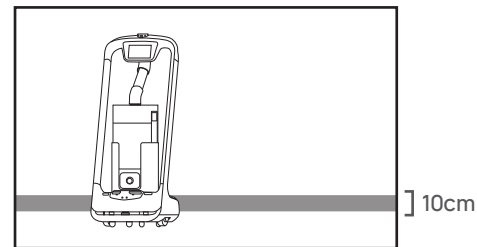

7. The ceiling height is within the range of 2-8 meters (higher or lower may require technical evaluation); taking the height of 3 meters as an example, it is necessary to apply a graphic mark every 2 meters or so, there is no lighting fixture or other strong light source in the 30cm area around the graphic mark. (Data for specific interval needs to be provided by Technology Dept.)

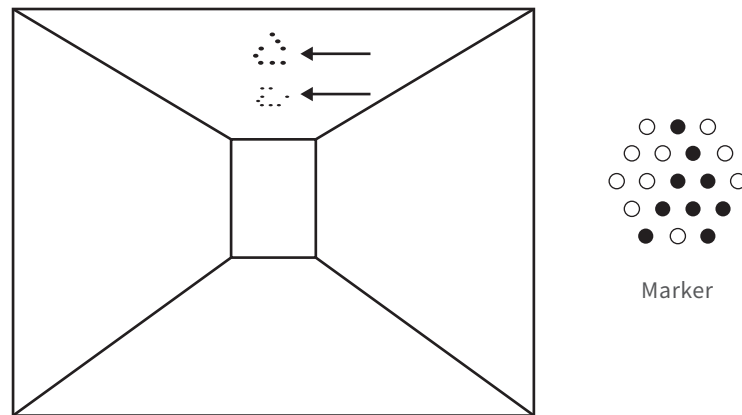

8. The designed maximum climbing angle of the robot is 5°, but in order to prevent the abnormality of the disinfection component, it is recommended that the slope of the operating environment for disinfection tasks should be within 2.5°; to prevent the robot from falling accidentally on the slope, the width of the slope should not be less than the minimum passing width of 0.80cm, and the rollover angle should not exceed 2.5°.

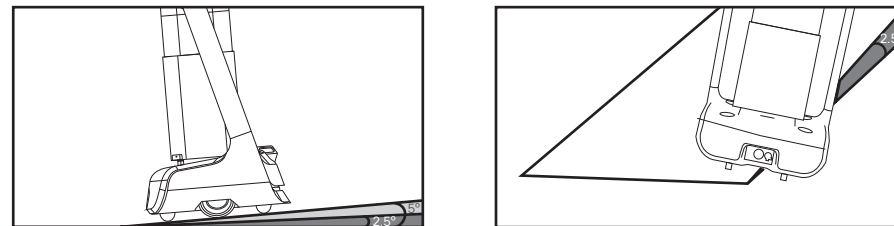

9. There is a 35cm space between the two robots placed side by side at the standby point, and a clearance of 15cm from the rear wall and 35cm from the side wall.

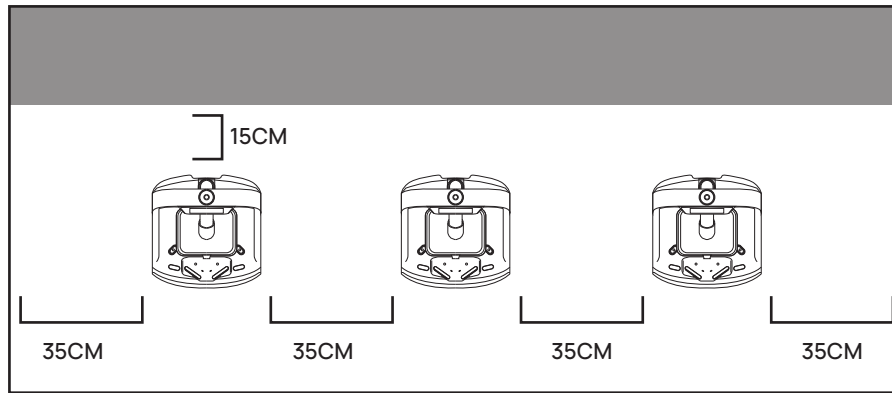

10. It is necessary to add fences or other blocking protection at the locations, such as the edge of the stairs and entrance of the downhill, where there is a risk of the robot falling.

## Power and power requirements

1. When the remaining power of the robot is less than 10%, please charge it in time, as low battery operation for a long time may shorten battery life.
2. After charging, please disconnect the power supply in time, be sure not to charge for a long time when the robot is fully charged.
3. If the robot is not used for a long time, please power off the product in time to protect the battery.
4. ALWAYS use the original rechargeable battery and charging device, NEVER use a non genuine charger to charge the robot.
5. Charge the main unit according to the power supply voltage indicated on the nameplate of charger.
6. Make sure that the power supply voltage meets the voltage indicated on the charger, otherwise the charger may be damaged.
7. Carefully protect the power cord from pulling and twisting.
8. Please designate a full-time staff to charge the robot, be sure not to charge it unattended.
9. Be sure not to charge the robot near flammable or explosive objects.
10. Please keep the robot's storage and charging position dry and at normal temperature, it is strictly prohibited to place the robot and charger in high temperature area ( $>40^{\circ}\text{C}$ ), and it is forbidden to allow water entering the robot and charger.
11. It is strictly forbidden that the charger collides with foreign objects, causing damage to the charger.
12. If the charger is found damaged or the charging current is abnormal, please replace the charger in time.
13. When receiving a robot alarm, disconnect the charging device immediately.

\*因不当操作所引发的所有意外, 本公司不承担任何责任。

## Safety instructions

1. DO NOT place any open flame on the robot, and DO NOT place any flammable solids, gases or liquids.
2. It is forbidden to do cleaning and maintenance work when the machine is powered on.
3. To ensure safety, it is recommended to adjust the robot speed to medium or below, and it is forbidden to play in front of the robot to avoid unnecessary injury.
4. Temporary refilling of disinfectant is prohibited during the robot's travel, all operations should be performed after tapping the screen to stop the robot from moving.
5. When refilling disinfectant, be careful not to spill the disinfectant into the robot.
6. If the robot is going away and the screen operation is invalid, or other emergency situations occur, please use the toe to kick the emergency switch at the charging port.
7. This product is a wheeled robot, which is limited to indoor flat environment (smooth ground, slope less than 5 degrees, protrusions not higher than 1cm), DO NOT use it in outdoor environments (such as open balconies) or on rugged floors (such as stairs).
8. DO NOT use it in an environment where the ambient temperature is above 40°C or below 0°C, or if there is any liquid or viscous material on the floor.
9. Please put away all kinds of wires on the ground in the environment before use to avoid dragging when the main unit is running. Remove sharp objects on the ground (such as decoration waste, glass, nails, etc.) before use to avoid damage to the machine chassis.
10. To push or move the robot while it is moving, first tap the screen to pause it.
11. DO NOT spill any liquid into the product.
12. The robot has automatic obstacle avoidance function, but it is strictly forbidden to block the robot suddenly during the high-speed operation, otherwise it may cause a safety accident.

13. The blind-spot recognition area of the robot is shown below.

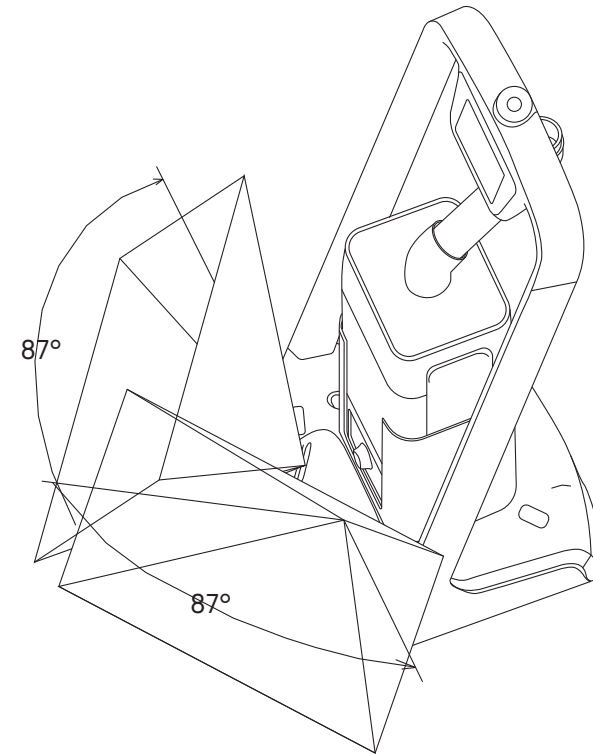

\* Our company does not assume any responsibility for all accidents caused by improper operation.

# Product Composition

## Component description

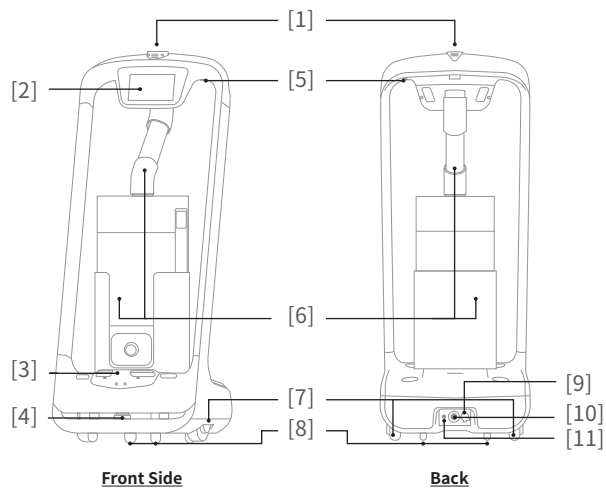

- [1] Vision positioning sensor
- [2] Screen
- [3] Depth vision sensor
- [4] Lidar
- [5] Power Switch
- [6] Disinfection component
- [7] Drive Wheel
- [8] Auxiliary Wheel
- [9] Key Switch
- [10] E-stop Switch
- [11] Charging Jack

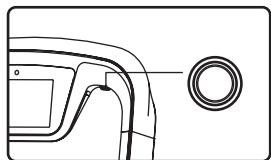

Power Switch

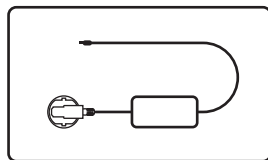

Charging Cable

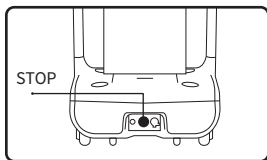

E-stop Switch

## Performance parameters

Model	PT1
Operating voltage	DC 23-29.4V
Power input	AC 100-240V, 50/60Hz
Power output	29.4V-3.5A
Charging time	6.5h
Battery lifetime	4~8h
Cruise speed	0.5~1.2m/s adjustable
Applicable disinfection area	150m <sup>2</sup> ~600m <sup>2</sup>
Size of disinfection component	310*250*620mm
Atomization rate of disinfectant	2000mL/h
Disinfectant tank capacity	23.8L
Climbing slope	Climbing slope: maximum 5°, safe operation 2.5°
Machine material	ABS/aviation-grade aluminum alloy
Battery capacity	21000mAh
Machine weight	37Kg
Machine size	516*500*1288(mm)
Screen specifications	7-inch HD color touch screen
Audio power	20W*2 Stereo
Design life	10 years
Working temperature	0~40°C
Storage temperature	-40~65°
Charging method	Manual plugging and charging
Operating humidity	85%RH
Environmental pollution	Grade 3
Operating altitude	below 2000m
Working environment	Indoor environment, flat and smooth ground
Enclosure	IP20

## Introduction to disinfection component

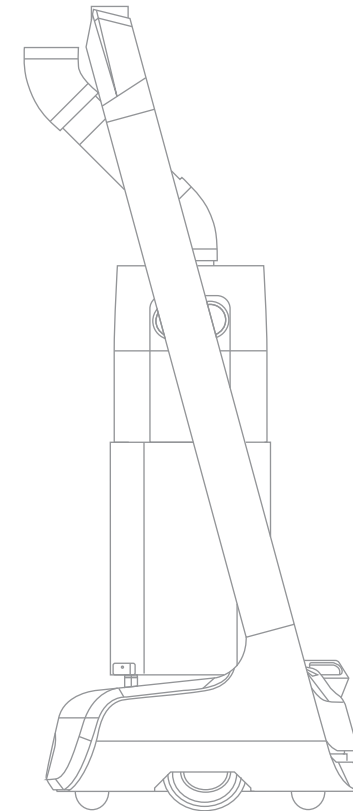
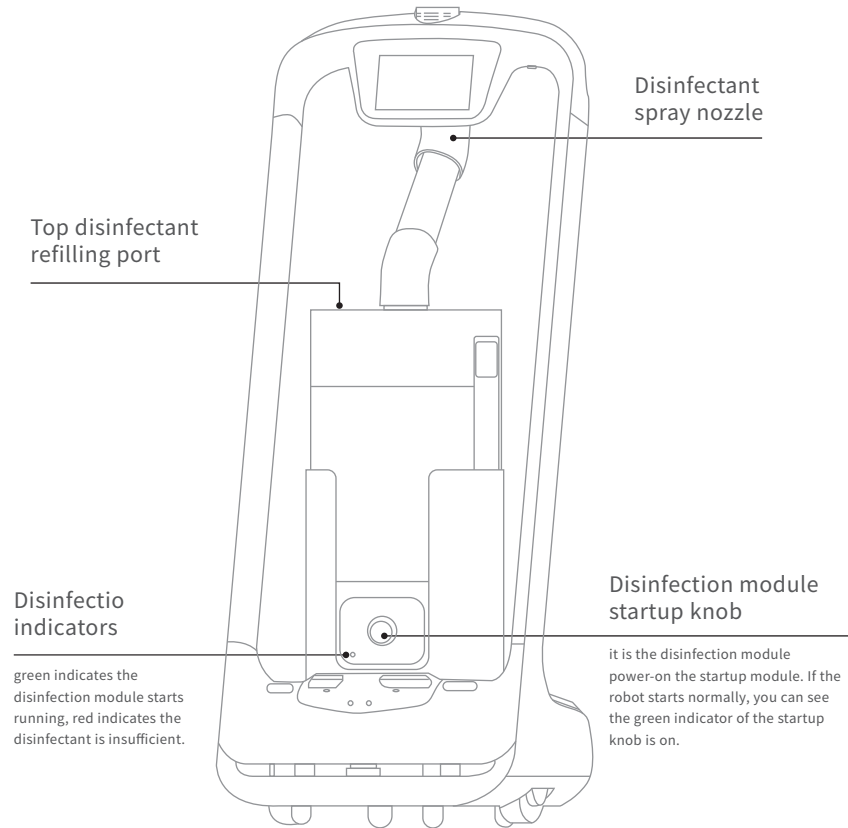



## Product Use

### Charging instructions

Charging mode: Connect the charging interface of the robot to the charging cable to ensure that the charging port of the robot is connected to the charging cable, if the connection is successful, the robot will prompt it is charging.

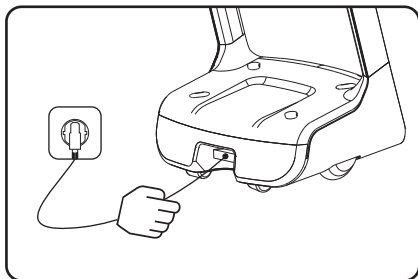
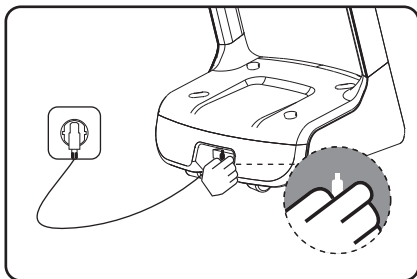

Power requirements:

1. In order to ensure the efficiency of the robot and battery life, please keep the robot power at 10% or more at any time;
2. When the power is lower than 10%, the robot is in a low battery state and needs to be charged as soon as possible;
3. When the power is lower than 2%, the battery is protected, the robot will not be able to perform the task, and it needs to be charged before use.

### Charging interface

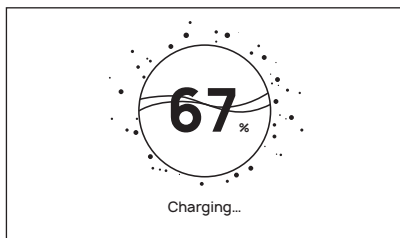

The screen displays an indication that charging is in progress, indicating that the machine is charging.

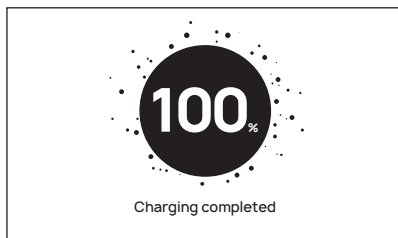

After charging is complete, the screen displays a reminder that the charging container is saturated.

### Power ON, Power OFF, Pause, Start

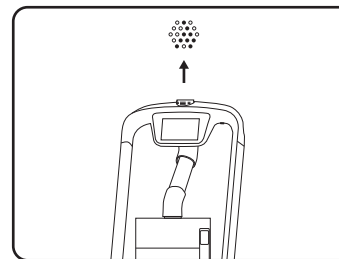

#### Before each power-on

Move the robot directly below the visual mark before each power-on.

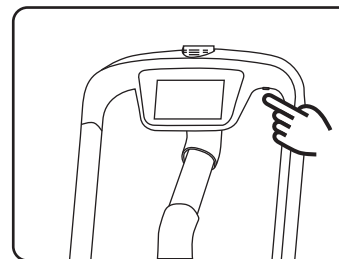

#### Power-on

Press and hold the power button for 3 seconds, and the bottom light strip will display blue.

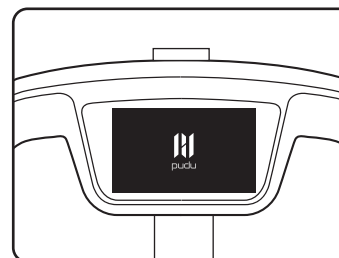

#### starting up

The screen enters the working mode, indicating that the boot is successful.

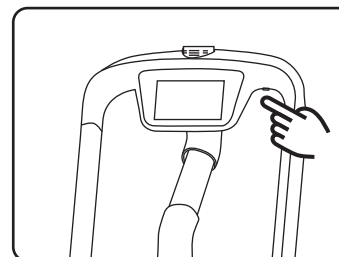

#### Power-off

Press and hold the power off button for 3 seconds, the bottom light strip is off, and the screen is black, indicating that the shutdown is successful.

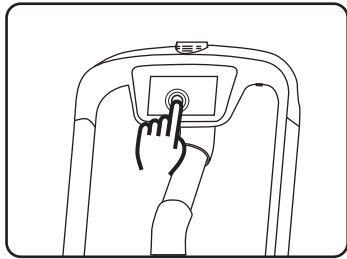

### Pause

While the robot is running, touch the screen to make the robot pause.

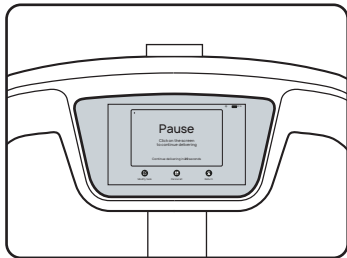

### Pausing

The screen enters the pause interface.

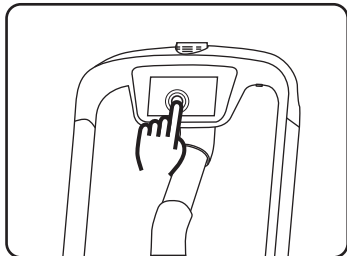

### Running

If it is necessary to continue running, you need to click the screen again. In disinfection mode, if there is no other action in the pause interface, the robot will automatically resume moving after 20s.

### Disinfection mode

Disinfection mode: In the disinfection mode, the robot performs intelligent circular motion according to the route selected by the user, after entering the route, the robot starts the disinfection component and starts atomizing the disinfectant to disinfect the environment; during operation, the robot does not play voice.

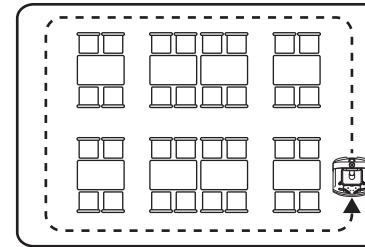

The disinfection mode is the basic function of the robot, and the specific steps are as follows:

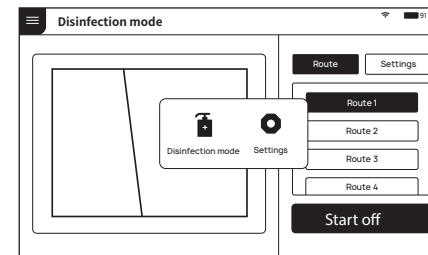

1. Select the disinfection mode at the parking location.
2. Add disinfectant, or make sure that a sufficient amount of disinfectant has been added to the disinfection component.

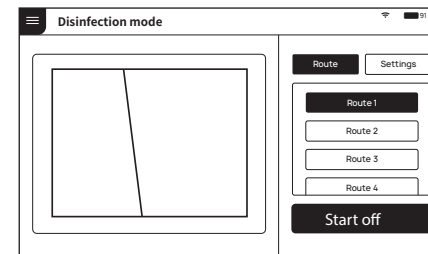

3. Select the disinfection route required for the current task.

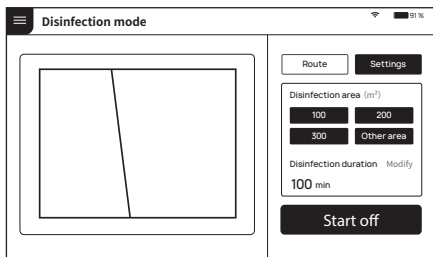

4. Select or enter the indoor space area of the disinfection task.
5. Please make sure that the disinfection mode knob is turned on before the disinfection task, otherwise the robot cannot start working.

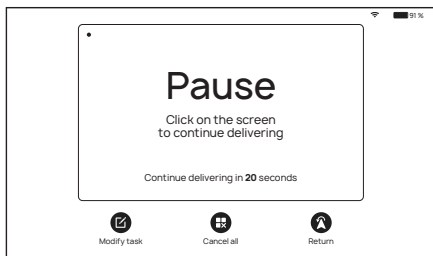

6. After pausing during a task, the screen enters this interface, you can perform operations such as modifying the task, returning to parking location, and canceling all tasks.

## Alarm display

In the following cases, the robot will stop working and give an alarm tone, the tablet interface will prompt the corresponding instructions, and the machine will need your assistance.

Alarm display	Solutions
Battery is too low	Please push the robot back for charging(Figure 1)
Loss of positioning	Push the robot directly below the visual mark (Figure 2)

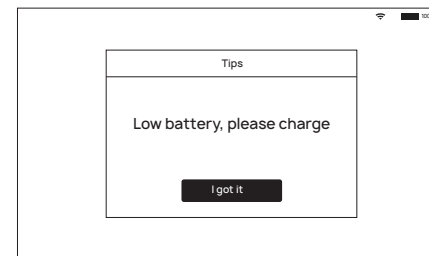

(Figure 1)

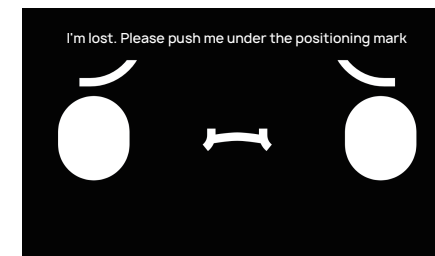

(Figure 2)

## Emergency handling

An abnormal state of the robot or an unexpected situation may cause damages to the surrounding environment, the user can press the emergency stop switch at the bottom to stop the robot.

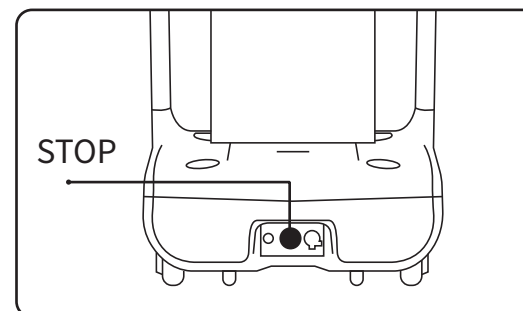

# Service functions

## Map settings

In the “Map settings” function, you can select from multiple maps. In the robot one-to-one parking mode, select the current map to configure the parking position for the robot.

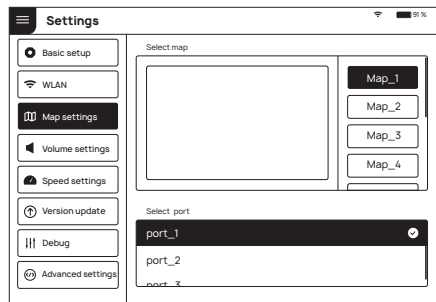

## Voice settings

The “Voice settings” function provides voice packet replacement and custom settings of cruise voice.

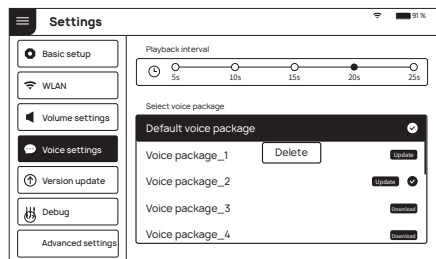

1. Check the available voice packets for update support and choose to download the voice packets.
2. After downloading, select the corresponding voice packet for replacement.
3. Select “Default” to restore the default voice packet
4. Press and hold the voice packet to delete it.

## Speed settings

With the “Speed settings” function, you can set the disinfection speed, supporting the speed settings of 0.5m/s, 0.6m/s, 0.7m/s, 0.8m/s and 0.9m/s.

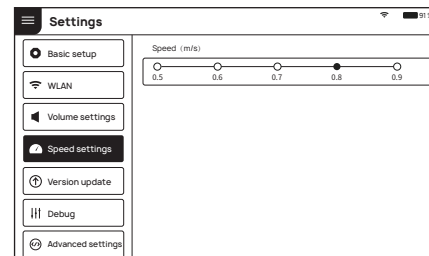

## Version upgrade

With the “Version upgrade” function, you can check the current version and whether it is up-to-date. If it is not up-to-date, you can choose to check for updates, download and update the latest version.

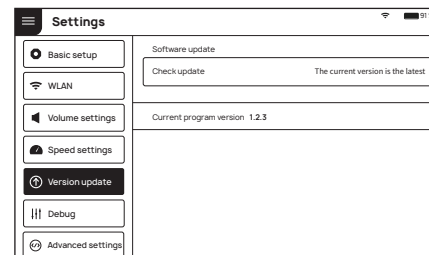

## Advanced settings

Select advanced settings to set the speed of the disinfection mode, supporting 1.0m/s, 1.1m/s and 1.2m/s.

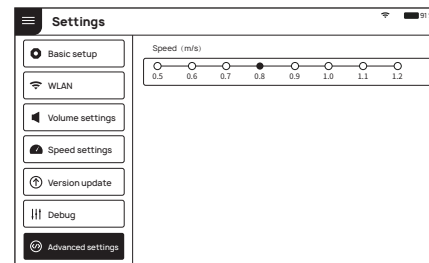

Note: The commissioning setting is advanced robot operation, which requires consulting technical support personnel before proceeding with the operation, the Company does not assume any responsibility for all accidents caused by unauthorized operation.

## Parking instructions

According to the size of the use scene location, there are three robot parking options available.

1. One-to-one parking: fixed parking locations can be set for each robot.
2. Free mode: multiple parking locations can be set the robots, and the robots can be parked according to priority.
3. Parking replenishment mode: In addition to the settings of parking locations in 1) and 2), you can also set temporary parking locations in other areas, and when there is location available, the robot can automatically go to the parking location for replenishment. When a robot is parking at non-parking location with no task designated, you can choose the "Return" command to let the robot return to the parking location automatically, or push the robot to the parking location.

Note: The robot at the temporary location will display "Temporary parking" in the normal state, when there is location available at food pick-up position, the robot will automatically to to the pick-up position for parking.



## Product Maintenance

### Disinfection component, drive wheel and auxiliary wheel

Keep the disinfection component clean and tidy, for disinfectant spray ports, check and clean at least once a week. Clean with a clean cotton cloth, when the bottom wheel is entangled or stuck by debris, the robot needs to be lifted for cleaning.

### Sensor maintenance

Keep the robot body clean with clean cotton cloth. Do not lift, climb, bump, push, or break the robot or stack things on its body. If it operates abnormally, do not uninstall any screw or open any cover without permission or instruction of our technical support engineers.

### Robot body maintenance

Keep the robot body clean with clean cotton cloth. Do not lift, climb, bump, push, or break the robot or stack things on its body. If it operates abnormally, do not uninstall any screw or open any cover without permission or instruction of our technical support engineers.

### Handling of robot

During the transportation of the robot, it is necessary to meet GB/T 4857.23-2012 requirements for road transport of steel spring vibration-damped trucks, please use forklifts and other handling tools for transportation. The robot is a valuable equipment, when you need to manually move the robot, please strictly follow the instructions below. As shown in the figure, the left and right profiles of the robot (indicated by the arrows) are the parts that can be stressed, and you can lift the robot through this part. Please ask two colleagues to lift the profile from both sides, pay attention to balance, and keep the robot's upright posture during the handling.

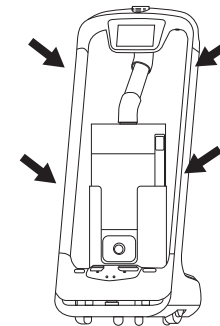

## Sign maintenance

No other objects (such as balloons, barbed wire, slogans, etc.) can be hung directly under the sign, and no billboards or safety exit signs can be hung near the sign; pay attention not to damage the sign during routine ceiling cleaning and maintenance, and the sign cannot be moved or rotated.

## Troubleshooting

### POST fails

If the robot has sufficient battery power, restart the robot under the positioning mark, if the self-test still fails, please contact the after-sales service personnel in time.

### Robot stops during operation

1. Click the interface to show the pause page, the robot pauses, click again to run normally.
2. Voice prompt "Excuse me": Click the screen to pause the robot, then the robot will be on the right track, then click Continue.

### "Signal Loss" prompt

The robot interface prompts "I am lost, please push me directly below the positioning mark". At this time, the robot will issue a voice prompt for help, please push the robot directly below the positioning mark.

### Robot can't boot normally

1. Check if the emergency switch is pressed or damaged, if it is damaged, please contact customer service.
2. The battery is insufficient, please connect the robot through the adapter for charging.
3. For other reasons, please contact customer service staff for processing.

## After Sales

### Free Warranty Services

Shenzhen Pudu Technology Co., Ltd undertakes that, under the following circumstances, from the date of product sale, a free product warranty service will be provided during the warranty period (the warranty period for different parts of the product may vary, see the [Main Parts Warranty] for details), and the customer does not need to pay for the inspection, labor, replacement parts, test fees and courier charges for the repairs. When the warranty period expires, a certain fee will be charged according to the normal price. Please contact the After-sales Service Hotline on official website for product maintenance.

### The following conditions must be met for the free warranty services

1. The purchased product is under normal use within the specified warranty period, and a non-human failure of performance occurs.
2. There is no unauthorized disassembly, no modification or addition against non-official instructions, and other non-human failures of performance.
3. The product serial number, factory label and other indications are not torn or altered.
4. Valid proof of purchase, documents and order number are available.
5. Damaged spare parts replaced during the free warranty period are owned by Pudu Technology and should be returned as requested by the Company, otherwise the Company reserves the right not to grant free warranty service.

### The free warranty service does not cover the following circumstances

1. Deliberate collision or burning accident caused by quality problems resulted from human operations, but not related to product.
2. Damage caused by unauthorized modification, dismantling, shell opening, etc., against unofficial instructions.
3. Damage caused by improper installation, use and operation that are not instructed by the instructions.
4. In the absence of official instructions, the damage caused by the customer's unauthorized repair to the assembly.
5. Damage caused by circuit modifications, improper use of battery packs and chargers against non-official instructions.
6. Damage caused by use over the safe load weight.
7. Damage caused by insufficient discharge when the battery is low or when using a battery with quality problems.
8. Failure or damage caused by force majeure factors (such as earthquakes, fires, etc.).
9. Other circumstances that do not meet the free warranty conditions.

### Under one of the following circumstances, a request for return can be made

1. Within 7 natural days after the customer receives the goods, the product has no manufacturing defects, the product packaging, accessories, gifts, and instructions are complete, and there is no human damage, and no impact on resale.
2. Within 7 natural days after the customer receives the goods, the customer finds obvious manufacturing defects before the goods are used.

### Under the following circumstances, we have the right to reject the customer's request for return

1. The goods were damaged, but the delivery person was not required for return on the spot upon customer's receipt of the goods.
2. The request for return is made after the valid period of 7 natural days for return of goods expires (calculated from the date of receipt).
3. The returned product is incomplete, the outer packaging, accessories, gifts, and instructions are incomplete, or the appearance has human damage.
4. Legal proof of purchase or receipt cannot be provided when returning, or to forge or alter the documents.
5. The occurrence of collisions, burns, and artificial modifications, the introduction of foreign objects (water, oil, sand, etc.), improper installation, failure to use and operate according to the instructions.
6. Tearing, altering of labels, machine serial number, waterproof mark, anti-counterfeit mark, etc.
7. Product damaged by force majeure such as fire, flood, lightning, traffic accidents, etc.
8. After contacting PuduTech to confirm the return service, if the corresponding item is not sent within 7 days from the date of contacting PuduTech, PuduTech has the right to reject such request.

### Under one of the following circumstances, a request for replacement can be made

1. Within 7 natural days after the customer receives the goods, the product has no manufacturing defects, the product packaging, accessories, gifts, and instructions are complete, and there is no human damage, and no impact on resale.
2. Within 15 natural days after the customer receives the goods, the customer finds obvious manufacturing defects before the goods are used.
3. Within 15 natural days after the customer receives the goods, the product cannot be started properly according to the instructions or under the guidance of the technicians after unpacking, or a non-human quality defect of the product is found.
4. The customer unpacks and inspects the goods in front of the delivery person upon receipt of the goods, and finds that the product is damaged due to transportation.
5. There is a clear discrepancy between the goods actually received and the description.

## Under the following circumstances, we have the right to reject the customer's request for replacement

1. When making the request for replacement, the customer fails to provide legal proof of purchase or documents, or the customer forges or alters the documents.
2. The goods were damaged, but the delivery person was not required for return or replacement on the spot upon customer's receipt of the goods.
3. The request for replacement is made after the valid period of 15 natural days for replacement of goods expires (calculated from the date of receipt).
4. The returned product is incomplete, the outer packaging, accessories, gifts, and instructions are incomplete, or the appearance is with human damage.
5. The goods are tested by the technical support department of PuduTech, and no quality problem is found with the product itself.
6. The occurrence of collisions, burns, and artificial modifications, the introduction of foreign objects (water, oil, sand, etc.), improper installation, failure to use and operate according to the instructions.
7. Tearing, altering of labels, machine serial number, waterproof mark, anti-counterfeit mark, etc.
8. Product damaged by force majeure such as fire, flood, lightning, traffic accidents, etc.
9. After contacting PuduTech to confirm the return service, if the corresponding item is not sent within 7 days from the date of contacting PuduTech, we have the right to reject such request.

## Process of after-sales service

1. Please contact PuduTech's technical support personnel at hotline: 400-0826-660 in time.
2. PuduTech's technical support personnel will record your product information in relevant forms.
3. PuduTech's technical support personnel will verify and carry out follow-up processing as soon as possible within 7 working days.

## Notice for goods replacing & returning & free-maintenance

1. Free door-to-door service  
The after-sales technical personnel will evaluate the application report you submitted and negotiate with you at the first time for the best solution such as remote technical support or door-door maintenance, and will handle it in time to give you the most satisfactory reply.
2. Processing time of returning goods  
After your application for return is approved, PuduTech will handle it within 7 days after the date we recorded when we received your problem goods in our official website.

3. Processing time of replacing goods  
After your application for replacement is approved, PuduTech will handle it within 15 days after the date we recorded when we received your problem goods in our official website.
4. Processing time of maintenance  
After your maintenance application is approved, PuduTech will repair the problem goods within 30 days after the date we recorded when we received your problem goods in our official website. The repair time will be delayed if there is national holiday or after-sales service center of some brand manufacturers is delayed. Please understand the inconvenience.
5. Processing time of refund  
The refund will be paid to your bank account within 10 working days after PuduTech receive your refunding goods. Please check with your issuing bank for details.

## After-sales Service Beyond the Scope of the Warranty

For after-sales services that are not covered by the free warranty (exceeding the warranty period or not meeting the free warranty terms during the warranty period), PuduTech provides after-sales services with a certain fee.

## Remote technical guidance service

Pudu Technology officially provides online and remote technical support channels (please refer to the product manual for details) to provide customers with technical guidance for remotely answering usage problems and preliminary problem diagnosis.

## On-site service

If Pudu Technology engineers diagnosed that they must go to the site to solve the problem, the Company may assign professional and technical personnel to provide on-site services.

## Standards for after-sales service fees

For after-sales services that are not covered by the free warranty, you need to fill in the Pudu Technology After-sales Service Record Form, as shown in Annex IX; the after-sales service costs of the Company include: spare parts costs and maintenance costs;

- a. For the after-sales issues with remote technical guidance services provided by Pudu Technology technicians and assistance by customers, Pudu Technology only charges the cost of spare parts;
- b. For the after-sales issues with on-site services provided by Pudu Technology technicians, the after-sales service costs include spare parts costs and maintenance costs, and the maintenance costs will be charged at: 500 Yuan/day in Guangdong Province and 1,000 Yuan/day outside Guangdong Province;



## After-sales Service Contact

If you have any question, please call our service hotline: 400-0826-660

PuduTech's after-sales service hours are: Monday to Saturday, 9:00 am to 12:00 am, 14:00 to 18:00 pm.

## Main Parts Warranty

Main components	Warranty period
Upper computer master control board	12 months
Upper computer expansion board	12 months
Upper computer cooling fan	12 months
Lower computer master control board	12 months
Audio amplifier board	12 months
Lidar	12 months
RGBD vision sensors	12 months
Audio device	12 months
Camera module	12 months
Disinfection component	12 months
Chassis lower front shell	12 months
Chassis left shell	12 months
Chassis right shell	12 months
Display assembly	12 months
Bottom light strip	12 months
Universal wheel	12 months
DC hub motor	12 months
Battery	12 months
E-stop switch	12 months
In-line charger	12 months