

TEST REPORT



Dt&C Co., Ltd.

42, Yurim-ro, 154Beon-gil, Cheoin-gu, Yongin-si, Gyeonggi-do, Korea, 17042
Tel : 031-321-2664, Fax : 031-321-1664

1. Report No : DRTFCC2403-0026

2. Customer

- Name (FCC) : DASAN Networks, Inc.
- Address (FCC) : DASAN Tower, 49, Daewangpangyo-ro644Beon-gil, Bundang-gu, Seongnam-si, South Korea 13493

3. Use of Report : FCC Original Grant

4. Product Name / Model Name : Telematics Gateway Unit / TGU (300611-02707)
FCC ID : 2AXDMTGU5GGLOBAL

5. FCC Regulation(s): Part 96

Test Method used: KDB971168 D01v03, ANSI/TIA-603-E-2016, ANSI C63.26-2015

6. Date of Test : 2023.12.28 ~ 2024.02.20



7. Location of Test : Permanent Testing Lab On Site Testing

8. Testing Environment : See appended test report.

9. Test Result : Refer to the attached Test Result

The results shown in this test report refer only to the sample(s) tested unless otherwise stated.

This test report is not related to KOLAS accreditation.

Affirmation	Tested by	Technical Manager
	Name : SeungMin Gil 	Name : JaeJin Lee  (Signature)

2024 . 03 . 08 .

Dt&C Co., Ltd.

If this report is required to confirmation of authenticity, please contact to report@dtnc.net

Test Report Version

Test Report No.	Date	Description	Revised by	Reviewed by
DRTFCC2403-0026	Mar. 08, 2024	Initial issue	SeungMin Gil	JaeJin Lee

Table of Contents

1. GENERAL INFORMATION	4
2. INTRODUCTION	6
2.1. EUT DESCRIPTION	6
2.2. TESTING ENVIRONMENT	6
2.3. MEASURING INSTRUMENT CALIBRATION.....	6
2.4. MEASUREMENT UNCERTAINTY	6
2.5. TEST FACILITY.....	6
3. DESCRIPTION OF TESTS.....	7
3.1. MAXIMUM OUTPUT POWER	7
3.2. UNDESIRABLE EMISSIONS	9
4. LIST OF TEST EQUIPMENT	11
5. SUMMARY OF TEST RESULTS.....	12
6. SAMPLE CALCULATION	13
7. TEST DATA.....	14
7.1. MAXIMUM OUTPUT POWER	14
7.2. UNDESIRABLE EMISSIONS (Radiated).....	16

1. GENERAL INFORMATION

FCC Classification	Citizens Band End User Devices (CBE)
FCC ID	2AXDMTGU5GGLOBAL
Product Name	Telematics Gateway Unit
Model Name	TGU (300611-02707)
Add Model Name	-
FVIN(Firmware Version Identification Number)	V0.03
EUT Serial Number	No specified
Supplying power	DC 24 V, 12 V
Waveform	CP-OFDM, DFT-S-OFDM
Modulation type	$\pi/2$ BPSK, QPSK, 16QAM, 64QAM, 256QAM

Antenna Information (5GNR)

NR Band	Internal Chip Antenna 1 (dBi)	External Antenna 1 (dBi)	Internal Chip Antenna 2 (dBi)	External Antenna 2 (dBi)
n48	3.3	3.4	0.6	3.9

Note: The antenna gain was corrected for path loss from the conducted feed point to the antenna terminal.

Transmitting configuration and Directional Gain

-	Transmitting configuration	Directional Gain(dBi) ^{Note2}
SISO	Internal Chip Antenna 2	0.6
SISO	External Antenna 2	3.9
MIMO	Internal Chip Antenna 1 + Internal Chip Antenna 2	2.2
MIMO	External Antenna 1 + External Antenna 2	3.7

Note 1. The device supports the MIMO for NR band n48.

Note 2. Directional gain (Uncorrelated signal with unequal antenna gain and equal transmit power)

$$10 \log [(10^{G1/10} + 10^{G2/10} + \dots + 10^{GN/10}) / N_{ANT}] \text{ dBi}$$

NR Frequency Band	Channel Bandwidth (MHz)	Modulation	TX Frequency (MHz)	Conducted Output Power (dBm)		EIRP	
				Max power (dBm)	Max power (W)	Max power (dBm)	Max power (W)
n48	40	$\pi/2$ BPSK	3 570.00 ~ 3 679.98	15.15	0.033	19.05	0.080
n48	40	QPSK	3 570.00 ~ 3 679.98	15.13	0.033	19.03	0.080
n48	40	16QAM	3 570.00 ~ 3 679.98	14.72	0.030	18.62	0.073
n48	40	64QAM	3 570.00 ~ 3 679.98	13.72	0.024	17.62	0.058
n48	40	256QAM	3 570.00 ~ 3 679.98	11.26	0.013	15.16	0.033
n48	20	$\pi/2$ BPSK	3 560.01 ~ 3 690.00	15.13	0.033	19.03	0.080
n48	20	QPSK	3 560.01 ~ 3 690.00	15.12	0.033	19.02	0.080
n48	20	16QAM	3 560.01 ~ 3 690.00	14.41	0.028	18.31	0.068
n48	20	64QAM	3 560.01 ~ 3 690.00	13.33	0.022	17.03	0.050
n48	20	256QAM	3 560.01 ~ 3 690.00	11.14	0.013	15.04	0.032
n48	10	$\pi/2$ BPSK	3 555.00 ~ 3 694.98	15.12	0.033	19.02	0.080
n48	10	QPSK	3 555.00 ~ 3 694.98	15.14	0.033	19.04	0.080
n48	10	16QAM	3 555.00 ~ 3 694.98	14.33	0.027	18.23	0.067
n48	10	64QAM	3 555.00 ~ 3 694.98	12.82	0.019	16.72	0.047
n48	10	256QAM	3 555.00 ~ 3 694.98	11.26	0.013	15.16	0.033

2. INTRODUCTION

2.1. EUT DESCRIPTION

This device supports the following capabilities:

Bluetooth LE, WCDMA, LTE/LTE up-link carrier aggregation, 5G NR(FR1)/5G NR up-link carrier aggregation and ENDC

5G NR supports SCS 15 kHz for FDD Band and SCS 30 kHz for TDD Band.

2.2. TESTING ENVIRONMENT

Ambient Condition	
▪ Temperature	+21 °C ~ +22 °C
▪ Relative Humidity	38 % ~ 40 %

2.3. MEASURING INSTRUMENT CALIBRATION

The measuring equipment, which was utilized in performing the tests documented herein, has been calibrated in accordance with the manufacturer's recommendations for utilizing calibration equipment, which is traceable to recognized national standards.

2.4. MEASUREMENT UNCERTAINTY

The measurement uncertainties shown below were calculated in accordance with requirements of ANSI C 63.4-2014. All measurement uncertainty values are shown with a coverage factor of $k = 2$ to indicate a 95 % level of confidence.

Parameter	Measurement uncertainty
Radiated Disturbance (Below 1 GHz)	5.0 dB (The confidence level is about 95 %, $k = 2$)
Radiated Disturbance (1 GHz ~ 18 GHz)	4.8 dB (The confidence level is about 95 %, $k = 2$)
Radiated Disturbance (Above 18 GHz)	5.0 dB (The confidence level is about 95 %, $k = 2$)

2.5. TEST FACILITY

Dt&C Co., Ltd.	
The 3 m test site and conducted measurement facility used to collect the radiated data are located at the 42, Yurim-ro, 154beon-gil, Cheoin-gu, Yongin-si, Gyeonggi-do, Korea 17042.	
The test site complies with the requirements of Part 2.948 according to ANSI C63.4-2014.	
- FCC & IC MRA Designation No. : KR0034	
- ISED#: 5740A	
www.dtnc.net	
Telephone	: + 82-31-321-2664
FAX	: + 82-31-321-1664

3. DESCRIPTION OF TESTS

3.1. MAXIMUM OUTPUT POWER

Conducted Output Power Test Set-up

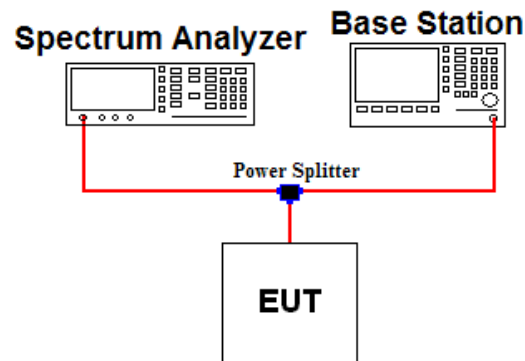

Test Procedure

- KDB971168 D01v03 - Section 5.4
- ANSI C63.26-2015 – Section 5.2.4.5, 5.2.4.4.2

Test setting

1. Set span to 2 x to 3 x the OBW.
2. Set RBW = 10 MHz
3. Set VBW \geq 3 x RBW.
4. Set number of points in sweep \geq 2 \times span / RBW.
5. Sweep time:
 - 1) Set = auto-couple, or
 - 2) Set \geq [10 \times (number of points in sweep) \times (transmission symbol period)] for single sweep (automation-compatible) measurement.
6. Detector = power averaging (rms).
7. Set sweep trigger to "free run"
8. Trace average at least 100 traces in power averaging (rms) mode if sweep is set to auto-couple. To accurately determine the average power over the on and off time of the transmitter, it can be necessary to increase the number of traces to be averaged above 100, or if using a manually configured sweep time, increase the sweep time.
9. By using the marker function to identify the maximum PSD instead of summing the power across the OBW.
10. Add 10 log (1/duty cycle) to the measured power level to compute the average power during continuous transmission. For example, add [10 log (1/0.25)] = 6 dB if the duty cycle is a constant 25 %.

EUT duty cycle

NR Band	T _{on} (ms)	T _{on+off} (ms)	Duty cycle = T _{on} / (T _{on+off})	10 log (1/duty cycle)
n48	1.0	5.0	0.2	7.0 dB

- ERP & EIRP (Effective Radiated Power & Equivalent Isotropic Radiated Power)

Test Procedure

- KDB971168 D01v03 - Section 5.6
- ANSI C63.26-2015 – Section 5.2.5.5

Determining ERP and EIRP from conducted RF output power measurement results

$$\text{ERP or EIRP} = P_{\text{Meas}} + G_{\text{T}} - L_{\text{C}}$$

where:

ERP or EIRP = effective radiated power or equivalent isotropically radiated power, respectively (expressed in the same units as P_{Meas} , typically dBW or dBm);

P_{Meas} = measured transmitter output power or PSD, in dBm or dBW;

G_{T} = gain of the transmitting antenna, in dBd (ERP) or dBi (EIRP);

L_{C} = signal attenuation in the connecting cable between the transmitter and antenna, in dB.

3.2. UNDESIRABLE EMISSIONS

Test Set-up

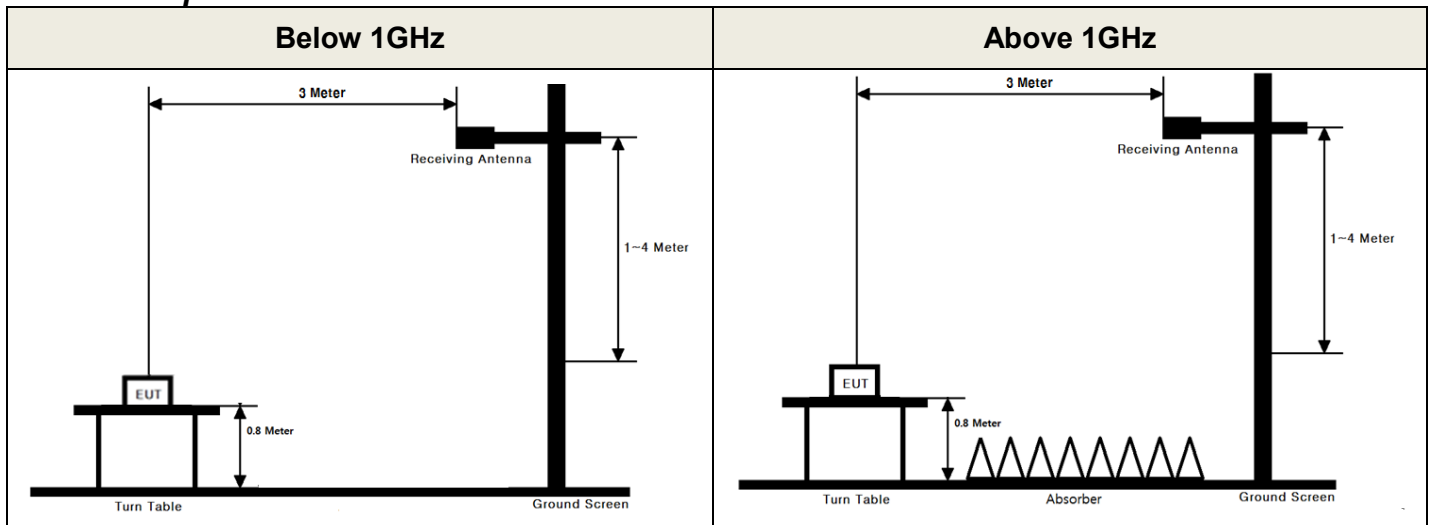

These measurements were performed at 3 test site. The equipment under test is placed on a non-conductive table 0.8 or 1.5 meters above a turntable which is flush with the ground plane and 3 meters from the receive antenna. For measurements above 1GHz absorbers are placed on the floor between the turn table and the antenna mast in such a way so as to maximize the reduction of reflections. For measurements below 1 GHz, the absorbers are removed.

Test Procedure

- ANSI/TIA-603-E-2016 - Section 2.2.12
- KDB971168 D01v03 - Section 5.8
- ANSI C63.26-2015 – Section 5.5

Test setting

1. RBW = 100 kHz for below 1 GHz and 1 MHz for above 1 GHz / VBW $\geq 3 \times$ RBW
2. Detector = RMS & Trace mode = Average
3. Sweep time = Auto couple
4. Number of sweep point $\geq 2 \times$ span / RBW
5. The trace was allowed to stabilize

If the device cannot be configured to transmit continuously (duty cycle $< 98\%$) and a free- running sweep must be used, set the sweep time so that the averaging is performed over multiple on/off cycles by setting the sweep time $>$ (number of points in sweep) \times (transmitter period) (i.e., the transmit on-time + the off-time). The spectrum analyzer readings shall subsequently be corrected by $[10 \log (1/\text{duty cycle})]$. This assumes that the transmission period and duty cycle is relatively constant (duty cycle variation $\leq \pm 2\%$).

The receive antenna height and turntable rotations were adjusted for the highest reading on the receive spectrum analyzer.

For radiated power measurements below 1 GHz, a half-wave dipole was substituted in place of the EUT. This dipole antenna was driven by a signal generator and the level of the signal generator was adjusted to obtain the same spectrum analyzer reading.

For radiated power measurements above 1 GHz, a Horn antenna was substituted in place of the EUT. This Horn antenna was driven by a signal generator and the level of the signal generator was adjusted to obtain the same spectrum analyzer reading. The difference between the gain of the horn and an isotropic antenna are taken into consideration.

4. LIST OF TEST EQUIPMENT

Type	Manufacturer	Model	Cal.Date (yy/mm/dd)	Next.Cal. Date (yy/mm/dd)	S/N
Spectrum Analyzer	Agilent Technologies	N9020A	23/12/15	24/12/15	MY50110097
Spectrum Analyzer	KEYSIGHT	N9020A	23/12/15	24/12/15	MY52440526
Spectrum Analyzer	KEYSIGHT	N9030B	23/12/15	24/12/15	MY55480168
Spectrum Analyzer	Rohde Schwarz	FSW85	23/12/15	24/12/15	101530
DC power supply	H.P	6633A	23/12/15	24/12/15	3524A06634
Multimeter	FLUKE	17B+	23/12/15	24/12/15	36390701WS
Radio Communication Analyzer	KEYSIGHT	E7515B	23/06/23	24/06/23	MY60192461
Thermohygrometer	BODYCOM	BJ5478	23/12/15	24/12/15	120612-1
Thermohygrometer	BODYCOM	BJ5478	23/12/15	24/12/15	090205-4
Power Splitter	Anritsu	K241B	23/06/23	24/06/23	020611
Signal Generator	Rohde Schwarz	SMBV100A	23/12/15	24/12/15	255571
Signal Generator	ANRITSU	MG3695C	23/12/15	24/12/15	173501
Loop Antenna	ETS-Lindgren	6502	23/11/09	24/11/09	00060496
Bilog Antenna	Schwarzbeck	VULB 9160	23/12/15	24/12/15	3362
HORN ANT	ETS	3117	23/12/15	24/12/15	00140394
HORN ANT	A.H.Systems	SAS-574	23/06/23	24/06/23	155
PreAmplifier	H.P	8447D	23/12/15	24/12/15	2944A07774
PreAmplifier	Agilent	8449B	23/12/15	24/12/15	3008A02108
PreAmplifier	tsj	MLA-1840-J02-45	23/06/23	24/06/23	16966-10728
High-pass filter	Wainwright	WHKX12-935-1000-15000-40SS	23/12/15	24/12/15	7
High-pass filter	Wainwright	WHKX10-2838-3300-18000-60SS	23/12/15	24/12/15	2
High-pass filter	Wainwright	WHKX6-6320-8000-26500-40CC	23/12/15	24/12/15	2
High-pass filter	Wainwright	WHNX5.0/26.5G-6SS	23/06/23	24/06/23	8
Cable	HUBER+SUHNER	SUCOFLEX100	24/01/03	25/01/03	M-1
Cable	HUBER+SUHNER	SUCOFLEX100	24/01/03	25/01/03	M-2
Cable	JUNKOSHA	MWX241/B	24/01/03	25/01/03	M-3
Cable	JUNKOSHA	MWX221	24/01/03	25/01/03	M-4
Cable	JUNKOSHA	MWX221	24/01/03	25/01/03	M-5
Cable	JUNFLON	J12J101757-00	24/01/03	25/01/03	M-7
Cable	HUBER+SUHNER	SUCOFLEX104	24/01/03	25/01/03	M-8
Cable	HUBER+SUHNER	SUCOFLEX106	24/01/03	25/01/03	M-9
Cable	JUNKOSHA	MWX315	24/01/03	25/01/03	M-10
Cable	JUNKOSHA	MWX241	24/01/03	25/01/03	mmW-1
Cable	JUNKOSHA	MWX241	24/01/03	25/01/03	mmW-4

Note1: The measurement antennas were calibrated in accordance to the requirements of ANSI C63.5-2017.

Note2: The cable is not a regular calibration item, so it has been calibrated by Dt&C itself.

5. SUMMARY OF TEST RESULTS

FCC Part Section(s)	Test Description	Test Limit	Status Note 1
96.41(b)	Maximum EIRP	< 23 dBm / 10MHz (End user device)	C
2.1053 96.41	Undesirable Emissions	< -40 dBm / MHz	C

Note 1: **C**=Comply **NC**=Not Comply **NT**=Not Tested **NA**=Not Applicable

Note 2: This device uses the certified module and the power configuration was reduced by software.

The output power and radiated test items were measured and spot-check testing were performed on other FCC requirements.(OBW, Conducted band edge, Conducted spurious emission) Spot-check test results do not exceed the module results.

Please refer to the module test report for conducted signal test items. (FCC ID: XMR2022RM520NGL)

Note 3: Radiated test items were performed in three orthogonal EUT positions and the worst case data was reported.

6. SAMPLE CALCULATION

A. For substitution method

Unwanted emissions

- 1) The EUT was placed on a turntable with 0.8 meter height for frequency below 1GHz and 1.5 meter height for frequency above 1 GHz respectively above ground.
- 2) The EUT was set 3 meters from the receiving antenna mounted on the antenna tower.
- 3) Vary the measurement antenna height through 1 m to 4 m and the rotate EUT through 360° in order to determine the maximum emission level.
- 4) Record the measured emission level and frequency using the available test method.
If required by the test method, add $10 \log(1/\text{duty cycle})$ to measured emission level.
- 5) Replace the EUT with dipole/Horn antenna that is connected to a calibrated signal generator.
- 6) Vary the measurement antenna height between 1 m to 4 m to maximize the received (measured) signal amplitude. And adjust the signal generator output power level until the amplitude detected by the measurement instrument equals the previously emission level[Measured level + $10 \log(1/\text{duty cycle})$].
- 7) The conducted power at the terminal of the substitute antenna is measured.
- 8) Record the level at substituted antenna terminal.
- 9) The result is calculated as below;

$$\text{EIRP(dBm)} = \text{LEVLE@ANTENNA TERMINAL} + \text{TX Antenna Gain (dBi)}$$

$$\text{ERP(dBm)} = \text{LEVLE@ANTENNA TERMINAL} + \text{TX Antenna Gain (dBd)}$$

$$\text{Where, TX Antenna Gain (dBd)} = \text{TX Antenna Gain (dBi)} - 2.15 \text{ dB}$$

7. TEST DATA

7.1. MAXIMUM OUTPUT POWER

- Test Notes

- 1) Conducted Output power(dBm/10MHz) = Reading value(dBm/10MHz) + 10 log (1/duty cycle)(dB)
 EIRP(dBm/10MHz) = Conducted Output power(dBm/10MHz) + EUT Antenna Gain(dBi)

SISO: External Antenna 2

Channel Bandwidth (MHz)	Frequency (MHz)	Modulation	RB Size/ Offset	Reading Value (dBm/10MHz)	10 log (1/duty cycle) (dB)	Conducted Output Power (dBm/10MHz)	Antenna Gain(dBi)	EIRP (dBm)
40	3 570.00	π/2 BPSK	1/Inner right	8.14	7.0	15.14	3.9	19.04
		QPSK	1/inner left	8.06	7.0	15.06	3.9	18.96
		16QAM	1/inner left	7.37	7.0	14.37	3.9	18.27
		64QAM	1/inner left	5.92	7.0	12.92	3.9	16.82
		256QAM	1/inner left	3.97	7.0	10.97	3.9	14.87
	3 624.99	π/2 BPSK	1/inner left	8.14	7.0	15.14	3.9	19.04
		QPSK	1/inner left	8.13	7.0	15.13	3.9	19.03
		16QAM	1/Inner right	7.27	7.0	14.27	3.9	18.17
		64QAM	1/Inner right	6.22	7.0	13.22	3.9	17.12
		256QAM	1/inner left	3.95	7.0	10.95	3.9	14.85
	3 679.98	π/2 BPSK	1/Inner right	8.15	7.0	15.15	3.9	19.05
		QPSK	1/Inner right	8.12	7.0	15.12	3.9	19.02
		16QAM	1/Inner right	7.72	7.0	14.72	3.9	18.62
		64QAM	1/Inner right	6.72	7.0	13.72	3.9	17.62
		256QAM	1/Inner right	4.26	7.0	11.26	3.9	15.16
20	3 560.01	π/2 BPSK	1/inner left	8.13	7.0	15.13	3.9	19.03
		QPSK	1/Inner right	8.12	7.0	15.12	3.9	19.02
		16QAM	1/Inner right	7.39	7.0	14.39	3.9	18.29
		64QAM	1/Mid	5.70	7.0	12.70	3.9	16.60
		256QAM	1/Inner right	3.55	7.0	10.55	3.9	14.45
	3 624.99	π/2 BPSK	1/inner left	7.99	7.0	14.99	3.9	18.89
		QPSK	1/inner left	8.00	7.0	15.00	3.9	18.90
		16QAM	1/Mid	7.15	7.0	14.15	3.9	18.05
		64QAM	1/Mid	6.13	7.0	13.13	3.9	17.03
		256QAM	1/inner left	3.92	7.0	10.92	3.9	14.82
	3 690.00	π/2 BPSK	1/Inner right	8.13	7.0	15.13	3.9	19.03
		QPSK	1/Inner right	8.10	7.0	15.10	3.9	19.00
		16QAM	1/Inner right	7.41	7.0	14.41	3.9	18.31
		64QAM	1/Mid	5.88	7.0	12.88	3.9	16.78
		256QAM	1/Mid	4.14	7.0	11.14	3.9	15.04
10	3 555.00	π/2 BPSK	1/Inner right	8.12	7.0	15.12	3.9	19.02
		QPSK	1/inner left	8.14	7.0	15.14	3.9	19.04
		16QAM	1/inner left	7.33	7.0	14.33	3.9	18.23
		64QAM	1/inner left	5.82	7.0	12.82	3.9	16.72
		256QAM	1/inner left	4.26	7.0	11.26	3.9	15.16
	3 624.99	π/2 BPSK	1/inner left	8.08	7.0	15.08	3.9	18.98
		QPSK	1/inner left	7.93	7.0	14.93	3.9	18.83
		16QAM	1/Inner right	7.05	7.0	14.05	3.9	17.95
		64QAM	1/Inner right	5.58	7.0	12.58	3.9	16.48
		256QAM	1/inner left	3.40	7.0	10.40	3.9	14.30
	3 694.98	π/2 BPSK	1/Inner right	7.79	7.0	14.79	3.9	18.69
		QPSK	1/Inner right	7.86	7.0	14.86	3.9	18.76
		16QAM	1/Inner right	6.73	7.0	13.73	3.9	17.63
		64QAM	1/Inner right	5.68	7.0	12.68	3.9	16.58
		256QAM	1/Inner right	3.40	7.0	10.40	3.9	14.30

MIMO: External Antenna 1 + External Antenna 2

Channel Bandwidth (MHz)	Frequency (MHz)	Modulation	RB Size/ Offset	Ext Ant 1 Conducted Output Power (dBm/10MHz)	Ext Ant 2 Conducted Output Power (dBm/10MHz)	Summed Conducted Output Power (dBm/10MHz)	Directional Antenna Gain(dBi)	EIRP (dBm)
40	3 570.00	QPSK	1/inner left	11.01	11.07	14.05	3.7	17.75
		16QAM	1/Mid	10.78	10.67	13.74	3.7	17.44
		64QAM	1/inner left	9.479	9.479	12.49	3.7	16.19
		256QAM	1/Mid	6.46	6.41	9.45	3.7	13.15
	3 624.99	QPSK	1/inner left	11.17	11.06	14.13	3.7	17.83
		16QAM	1/Mid	10.75	10.53	13.65	3.7	17.35
		64QAM	1/Mid	9.55	9.39	12.48	3.7	16.18
		256QAM	1/Mid	6.48	6.46	9.48	3.7	13.18
	3 679.98	QPSK	1/inner left	11.66	11.15	14.42	3.7	18.12
		16QAM	1/inner left	11.03	10.83	13.94	3.7	17.64
		64QAM	1/Mid	10.68	9.38	13.09	3.7	16.79
		256QAM	1/Mid	6.9	6.48	9.71	3.7	13.41
20	3 560.01	QPSK	1/inner left	11.06	11.07	14.08	3.7	17.78
		16QAM	1/Mid	10.74	10.61	13.69	3.7	17.39
		64QAM	1/inner left	9.45	9.38	12.43	3.7	16.13
		256QAM	1/Mid	6.47	6.5	9.50	3.7	13.20
	3 624.99	QPSK	1/inner left	11.03	11.21	14.13	3.7	17.83
		16QAM	1/Mid	10.8	10.94	13.88	3.7	17.58
		64QAM	1/Mid	9.56	9.6	12.59	3.7	16.29
		256QAM	1/inner left	6.33	6.78	9.57	3.7	13.27
	3 690.00	QPSK	1/inner left	11.66	11.23	14.46	3.7	18.16
		16QAM	1/Mid	11.27	10.89	14.09	3.7	17.79
		64QAM	1/inner left	10.87	9.69	13.33	3.7	17.03
		256QAM	1/inner right	6.95	6.65	9.81	3.7	13.51
10	3 555.00	QPSK	1/inner left	11.12	11.25	14.20	3.7	17.90
		16QAM	1/Mid	10.72	10.94	13.84	3.7	17.54
		64QAM	1/Mid	9.58	9.58	12.59	3.7	16.29
		256QAM	1/Mid	6.43	6.69	9.57	3.7	13.27
	3 624.99	QPSK	1/inner left	11.06	11.08	14.08	3.7	17.78
		16QAM	1/Mid	10.6	10.65	13.64	3.7	17.34
		64QAM	1/inner left	9.6	9.44	12.53	3.7	16.23
		256QAM	1/Mid	6.48	6.45	9.48	3.7	13.18
	3 694.98	QPSK	1/inner left	11.12	11.13	14.14	3.7	17.84
		16QAM	1/inner left	10.62	10.81	13.73	3.7	17.43
		64QAM	1/inner left	9.59	9.34	12.48	3.7	16.18
		256QAM	1/Mid	6.46	6.46	9.47	3.7	13.17

7.2. UNDESIRABLE EMISSIONS (Radiated)

- Test Notes

- 1) Limit = -40 dBm/MHz
- 2) Result(dBm) = Level at Substitute antenna terminal(dBm) + Substitute Antenna Gain (dBi)
- 3) The frequency spectrum is examined from 9 kHz to the 10th harmonic of the fundamental frequency of the transmitter. No other spurious and harmonic emissions were reported greater than listed emissions above table.

- 5GNR n48

MIMO: Internal chip Antenna 1 + Internal chip Antenna 2

Channel Bandwidth (MHz)	Frequency (MHz)	Modulation	RB size/offset	Freq.(MHz)	Ant Pol (H/V)	Level at Antenna Terminal(dBm)	Substitute Antenna Gain(dBi)	Result (dBm)	Limit (dBm)	Margin (dB)
40	3 570	QPSK	1/104	7 177.98	H	-60.01	11.73	-48.28	-40.00	8.28
	3 624.99		1/1	7 210.66	H	-59.97	11.77	-48.20	-40.00	8.20
	3 679.98		1/104	7 397.90	H	-59.48	12.04	-47.44	-40.00	7.44

MIMO: External Antenna 1 + External Antenna 2

Channel Bandwidth (MHz)	Frequency (MHz)	Modulation	RB size/offset	Freq.(MHz)	Ant Pol (H/V)	Level at Antenna Terminal(dBm)	Substitute Antenna Gain(dBi)	Result (dBm)	Limit (dBm)	Margin (dB)
40	3 624.99	QPSK	1/1	7 211.78	H	-60.06	11.77	-48.29	-40.00	8.29