

EW-BLED-26
Bluetooth module

V1.0

About this Manual

<< EW-BLED-26 Module Specifications>> provides an introduction to the basic functions of the EW-BLED-26 module, including its electrical specifications, RADIO frequency performance, pin size, and reference schematic design. Readers can refer to this document for a detailed understanding of the overall functional parameters of the module.

Revision history

Rev. Information management

Rev No.	Date	Update history	Editor
V1.0	2020.12.08	Initial release	Jon

Contents

About this manual.....	2
Revision history.....	2
Contents.....	3
1. Profile.....	4
1.1 Features	4
1.2 Application scope.....	5
2. Electrical specification.....	6
3. Pins explanation.....	7
3.1 Pins layout.....	8
3.2 Pins definition.....	8
4. Design reference.....	9
4.1 Reference schematic.....	9
4.2 Module dimension.....	10
4.3 Attention.....	11
4.4 Reference PCB package.....	12
5. Reflow parameter recommendation.....	13

1.Profile

1.1 Features

EW-BLED -26 is a small and low-cost BT and BLE 5.0 dual-mode Bluetooth module developed by Jiaying Tech-leading Co., Ltd.

The features of this module are as follows:

- Built-in high performance RISC 32-bit CPU, 160MHz main frequency, 512KB Flash, 128KB RAM
- Meet Bluetooth 5.0 standard, support 1 Mbps, 500 Kbps, 125 Kbps rate
- Transmitting power: BLE:4.82dBm; BR(GFSK):0.24dBm; EDR($\pi/4$ -DQPSK):1.02dBm .
- Receiving sensitivity: The receiving sensitivity reaches -94dBm in 125Kbps mode
- Support USB, UART, ADC, SPI, PWM and other interfaces
- Support FTMS protocol, can be customized according to the customer communication protocol
- Support true random number generator
- Support BT classic Bluetooth and BLE data Bluetooth dual - mode operation
- On-board high performance PCB antenna
- Stamp hole pin, easy and reliable welding
- Ultra-small package: 11.2x16mm
- Ultra-wide supply voltage: 2.2V-5.5V
- Working temperature: -20℃ ~ + 70℃

The EW-BLED-26 module needs to connect the four lines of VCC,GND,TX and RX to complete the data transmission and communication function, and can customize the specific communication protocol and customization function under the specific application environment according to the needs of customers.After the module is configured, you can use relevant hand software to test the communication data function.Users can conduct Bluetooth connection and communication test through the commonly used mobile Bluetooth communication test tool. BT audio transmission can be directly connected to the two channels of DAC R and L of the test module through the mobile Bluetooth for audio signal output.

Tech-leading company has been engaged in the field of Bluetooth for many years, and has strong research and development strength. It can easily realize the interconnection, data transmission and other various applications of users' Bluetooth devices.Our company can customize and design the Bluetooth module according to customers' requirements based on the EW-BLED -26 dual mode Bluetooth module and provide corresponding software and hardware support.

1.2 Application Scope

IoT devices; Fitness equipment: treadmill, rhythm machine, etc

2. Electrical specifications

- Absolute Maximum Ratings

Rating		Min	Max	Unit
Supply Voltage	VCC	2.2	5.5	V
I/O Voltage	ALDO_OUT	2.2	3.6	V
Storage Temperature	Tstr	-20	70	°C

Attention:

The electrical characteristics listed are target specifications for reference only. Some of the data may be updated based on actual test results

The voltage values shown are based on GND in the module. Any voltage exceeding the "maximum rating" may cause permanent damage to the equipment

Recommended Operating Conditions

Item	Symbol	Min	Type.	Max	Unit
Supply Voltage	VCC	2.2	3.3	5.5	V
I/O Voltage	ALDO_OUT	2.2	3.3	3.6	V
Operating Temperature	Topr	-20	-	70	°C

Power Consumption

Operation Mode	Average	Maximum	Unit
TX peek current(0 dB)		16	mA
RX peek current		30	mA
Deep sleep current(include 128K retention RAM)	300		μA
Power off	10		μA

5

■ Audio CODEC

Digital to Analogue Converter(Mono)					
PARAMETER	CONDITIONS	MIN	TYP	MAX	UNIT
Resolution	-	-	-	20	Bits
Sampling frequency	The synchronized clock	8		48	kHz
SNR (Signal to Noise Ratio)	Fin=1kHz B/W=20Hz—20KHz A-Weighted THD_N<0.01% Fs(8K,16K,32K,44.1K,48K)		92		dB
Digital Gain	Digital Gain	-48		32	dB
Analogue Gain	Analog Gain Resolution =	0		-30	dB
Output voltage	VDDA=2.9V		1500		mV
Stopband attenuation		65			dB
Analog to Digital Converter(Mono)					
PARAMETER	CONDITIONS	MIN	TYP	MAX	UNIT
Resolution	-	-	-	16	Bits
Sampling frequency	The synchronized clock	8		48	kHz
Signal to Noise Ratio	A-weighted		79		dBFS
	W/O weighting		79		dBFS
Digital Gain	Digital Gain	-48		32	dB
Analogue Gain	Analog Gain Resolution =	0		30	dB

3. Pins description

3.1 Pins distribution

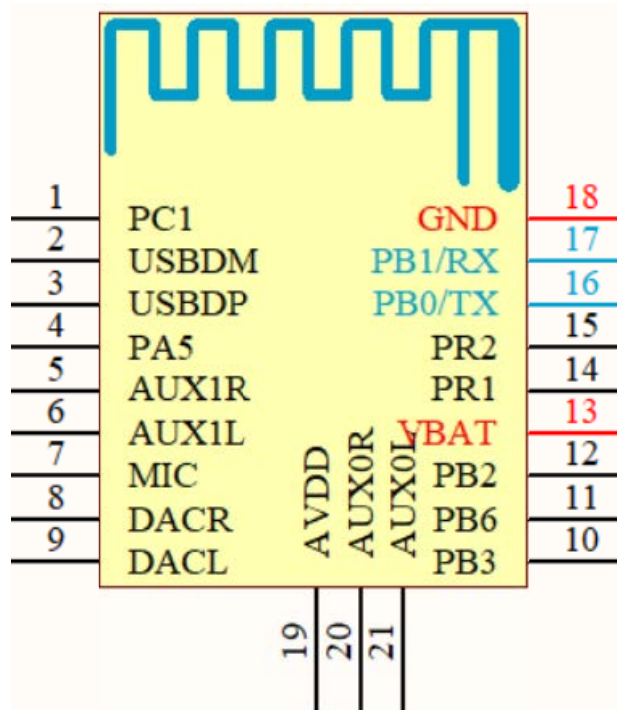

Figure 3-1 Module pins figure

Note: Figure 3-1 Pin functionality can be redefined by pin reuse

3.2 Pins definition

PIN #	Pin name	Type	Description
1	PA4	I/O	PWMH1H
2	USBDM	I/O	ADC11/USBDM
3	USBDP	I/O	USBDP
4	PA5	I/O	ADC2
5	PA3	I/O	PDC0/AUX1L/PA1
6	PA4	I/O	PWM1/ADC1/AUX1R
7	PA0	I/O	MIC
8	DACR	Analog Output	DACR
9	DACR	Analog Output	DACL
10	PB3	I/O	SD0DAT/AUX2R/PWM2
11	PB6	I/O	AUX2L
12	PB2	I/O	SPI2DIA/ UART2TXC/ SPI0_CLKB
13	VCC	POWER	VCC (2.2V~5.5V)
14	PR2	I/O	RESET1/ADC12
15	PR2	I/O	RESET2
16	PB0	I/O	ADC6/PWMH2L/TXD
17	PB1	I/O	ADC7/RXD
18	GND	GND	GND of module
19	VDDIO	IO POWER	VDDIO
20	PB5	I/O	SD0CLK/AUX0R/ADC9
21	PB4	I/O	SD0CMD/AUX0L/ADC8/PWM3

4.2 Module size

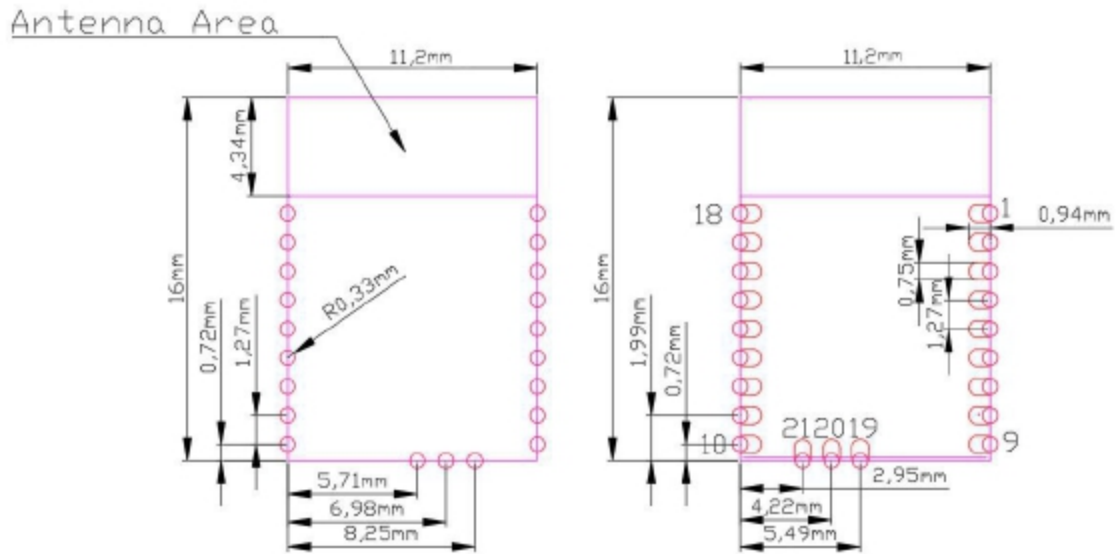

4-1 Top View (Seen from Top) Bottom View (Seen from Bottom)

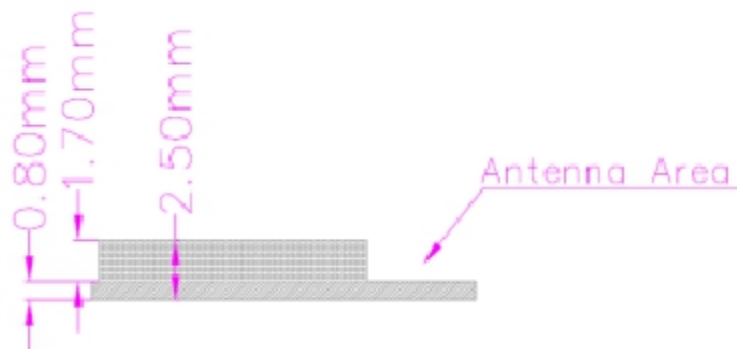

4-2 Module thickness

Note: Tech-Leadingcompany reserves the right to select components from different suppliers to realize the function of modules.All mechanical, electrical specifications and module certifications are maintained.All dimensions are in mm (mm)

Table 4-3 Module design size

Module profile size	Š^)* @ŸD	FFŒ€† €ŒÍ { {
	Y ãc@ŸD	FÍ Œ€ €ŒÍ { {
Antenna location size	Š^)* @ŸD	FFŒ€ { {
	Y ãc@ŸD	I ŒH { {
PCB thickness	P^ã @ŸD	€ŒÍ €† €ŒÍ { {
Total module thickness (PCB thickness maximum component height)	P^ã @ŸD	ŒŒÍ € { { €] ãc†

4.3 Attention

Bluetooth works at the frequency of 2.4GHz, so the influence of various factors on the wireless transceiver should be avoided as far as possible. Please note the following points:

Avoid using metal as part of the product housing surrounding the module. If the housing is metal, consider using an external antenna

The metal screws inside the product should be kept away from the RF part of the module To maximize RF performance, the user main board layout should follow the following recommendations:

Antenna clearance area: the user's main board located directly below the module antenna area shall not have any copper foil wiring, including power supply, ground and signal layer)。

Module location: Ideally, the module should be placed in a corner of the user's motherboard. The PCB antenna is located at the far end of the motherboard.This position minimizes the antenna clearance area。

(Refer to the following figure for the definition of antenna clearance area)

4- 4 Antenna Keep out

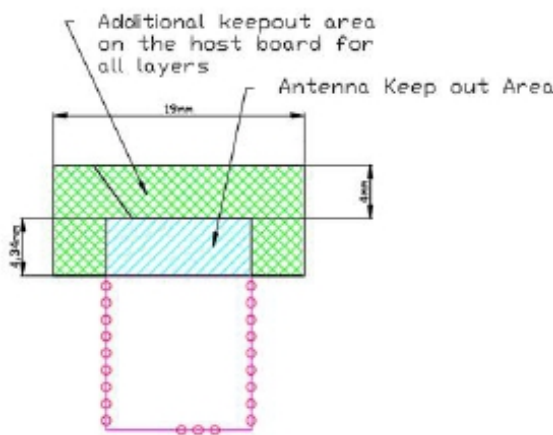

4.4 Reference PCB packaging

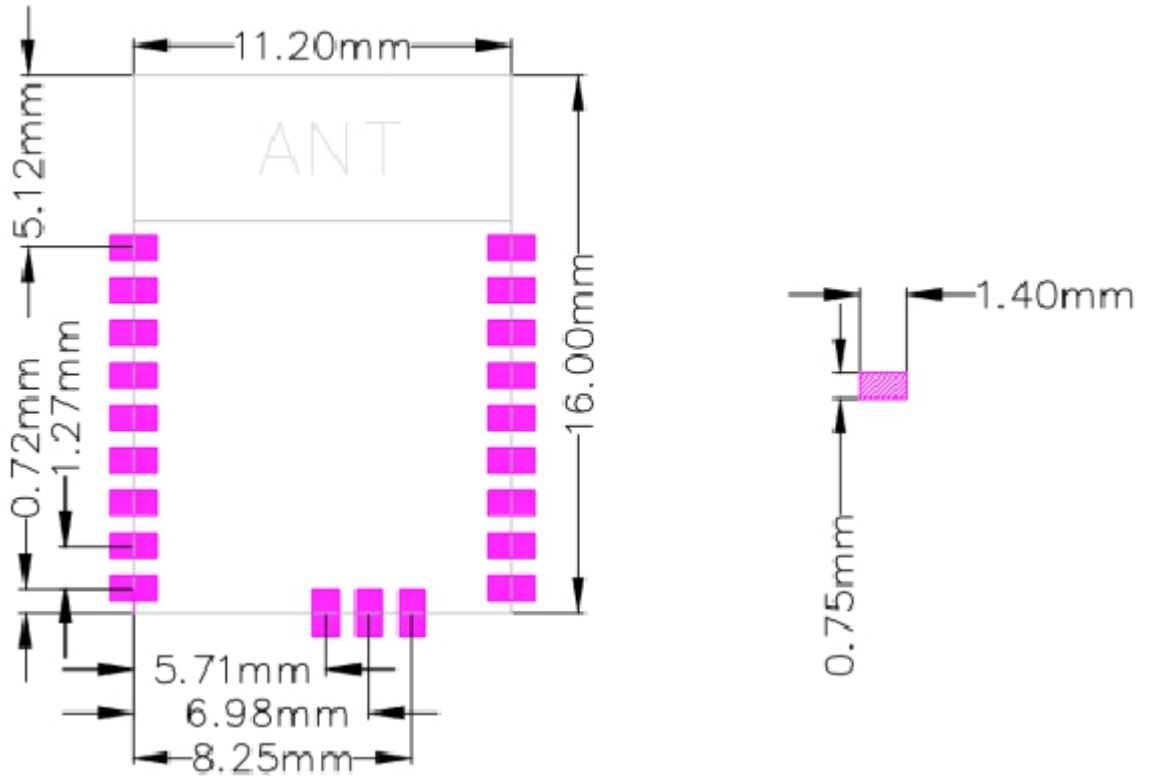

4-5 Reference packaging size

5. Reflow parameter recommendation

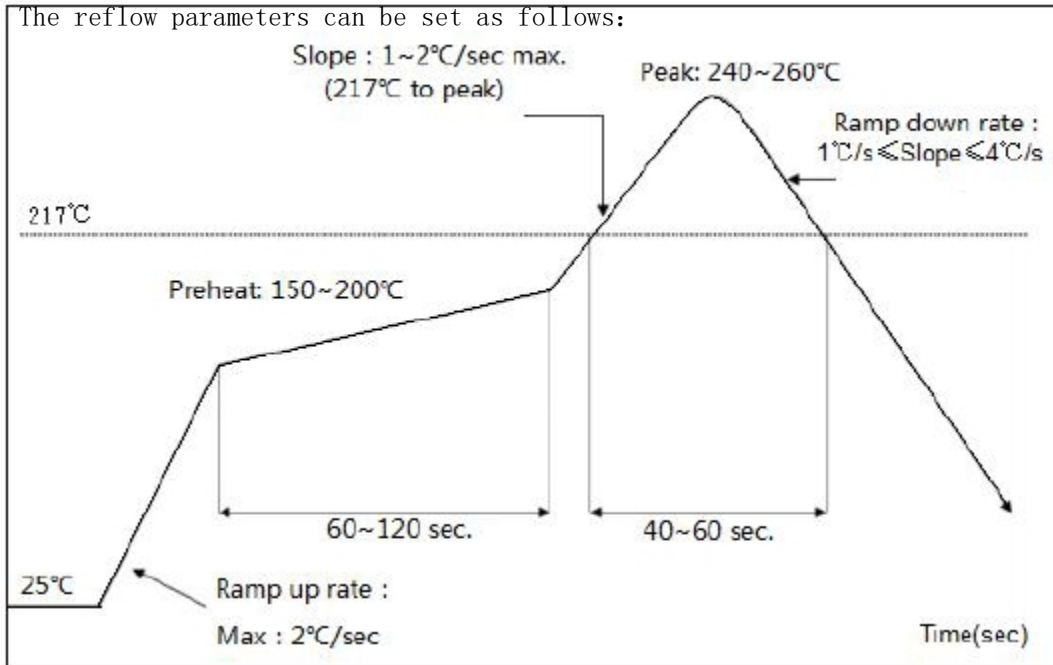

Figure 5-1 Recommended reflow curv

Wavelength (nm)	Wavelength (nm)	Wavelength (nm)
10~15°C	10~15°C	10~15°C
10~15°C	10~15°C	10~15°C
10~15°C	10~15°C	10~15°C
10~15°C	10~15°C	10~15°C

Table 5-1 Recommended parameters for reflow

FCC Statement:

Any Changes or modifications not expressly approved by the party responsible for compliance could void the user's authority to operate the equipment.

This device complies with part 15 of the FCC Rules. Operation is subject to the following two conditions: (1) This device may not cause harmful interference, and (2) this device must accept any interference received, including interference that may cause undesired operation.

OEM Guidance

1. Applicable FCC rules

This module is granted by Single Modular Approval. It complies to the requirements of FCC part 15C, section 15.247 rules.

2. The specific operational use conditions

This module can be used in IoT devices. The input voltage to the module is nominally 3.3V DC. The operational ambient temperature of the module is -20 to 70 degree C. Only the embedded PCB antenna is allowed. Any other external antenna is prohibited.

3. Limited module procedures

N/A

4. Trace antenna design

N/A

5. RF exposure considerations

The equipment complies with FCC radiation exposure limits set forth for an uncontrolled environment. This equipment can operated with minimum distance 5mm between the radiator and your body.

6. Antenna

Antenna type: PCB antenna; Antenna Gain: 0 dBi

7. Label and compliance information

An exterior label on OEM's end product can use wording such as the following: "Contains Transmitter Module FCC ID: 2AXDJ-EW-BLED-26" or "Contains FCC ID: 2AXDJ-EW-BLED-26"

8. Information on test modes and additional testing requirements

a) The modular transmitter has been fully tested by the module grantee on the required number of channels, modulation types, and modes, it should not be necessary for the host installer to re-test all the available transmitter modes or settings. It is recommended that the host product manufacturer, installing the modular transmitter, perform some investigative measurements to confirm that the resulting composite system does not exceed the spurious emissions limits or band edge limits (e.g., where a different antenna may be causing additional emissions).

b) The testing should check for emissions that may occur due to the intermixing of emissions with the other transmitters, digital circuitry, or due to physical properties of the host product (enclosure). This investigation is especially important when integrating multiple modular transmitters where the certification is based on testing each of them in a stand-alone configuration. It is important to note that host product manufacturers should not assume that because the modular transmitter is certified that they do not have any responsibility for final product compliance.

c) If the investigation indicates a compliance concern the host product manufacturer is obligated to mitigate the issue. Host products using a modular transmitter are subject to all the applicable individual technical rules as well as to the general conditions of operation in Sections 15.5, 15.15, and 15.29 to not cause interference. The operator of the host product will be obligated to stop operating the device until the interference have been corrected .

9. Additional testing, Part 15 Sub part B disclaimer The final host / module combination need to be evaluated against the FCC Part 15B criteria for unintentional radiators in order to be properly authorized for operation as a Part 15 digital device.

The host integrator installing this module into their product must ensure that the final composite product complies with the FCC requirements by a technical assessment or evaluation to the FCC rules, including the transmitter operation and should refer to guidance in KDB 996369. For host products with certified modular transmitter, the frequency range of investigation of the composite system is specified by rule in Sections 15.33(a)(1) through (a)(3), or the range applicable to the digital device, as shown in Section 15.33(b)(1), whichever is the higher frequency range of investigation When testing the host product, all the transmitters must be operating. The transmitters can be enabled by using publicly-available drivers and turned on, so the transmitters are active. In certain conditions it might be appropriate to use a technology-specific call box (test set) where accessory 50 devices or drivers are not available. When testing for emissions from the unintentional radiator, the transmitter shall be placed in the receive mode or idle mode, if possible. If receive mode only is not possible then, the radio shall be passive (preferred) and/or active scanning. In these cases, this would need to enable activity on the communication BUS (i.e., PCIe, SDIO, USB) to ensure the unintentional radiator circuitry is enabled. Testing laboratories may need to add attenuation or filters depending on the signal strength of any active beacons (if applicable) from the enabled radio(s). See ANSI C63.4, ANSI C63.10 and ANSI C63.26 for further general testing details.

The product under test is set into a link/association with a partnering device, as per the normal intended use of the product. To ease testing, the product under test is set to transmit at a high duty cycle, such as by sending a file or streaming some media content.