

DFS Test Report

Applicant : Kaonbroadband CO., LTD
Product Name : WiFi6E XGS-PON Gateway
Trade Name : KAON
Model Number : PG2494
Applicable Standard : FCC 47 CFR PART 15 SUBPART E
ANSI C63.10:2013
Received Date : Apr. 08, 2022
Test Period : May 12 ~ May 13, 2022
Issued Date : Jul. 29, 2022

Issued by

A Test Lab Techno Corp.
No. 140-1, Changan Street, Bade District,
Taoyuan City 334025, Taiwan (R.O.C.)
Tel : +886-3-2710188 / Fax : +886-3-2710190



Taiwan Accreditation Eoundation accreditation number: 1330

Frequency Range : 9 kHz to 40 GHz

Test Firm MRA designation number: TW0010

Note:

1. The test results are valid only for samples provided by customers and under the test conditions described in this report.
2. This report shall not be reproduced except in full, without the written approval of A Test Lab Technology Corporation.
3. The relevant information is provided by customers in this test report. According to the correctness, appropriateness or completeness of the information provided by the customer, if there is any doubt or error in the information which affects the validity of the test results, the laboratory does not take the responsibility.

Revision History

| Rev. | Issued Date | Revisions | Revised By |
|------|---------------|---------------|------------|
| 00 | Jul. 29, 2022 | Initial Issue | Snow Wang |
| | | | |
| | | | |
| | | | |

Verification of Compliance

Applicant : Kaonbroadband CO., LTD

Product Name : WiFi6E XGS-PON Gateway

Trade Name : KAON

Model Number : PG2494

FCC ID : 2AXCW-PG2494

Applicable Standard : FCC 47 CFR PART 15 SUBPART E
ANSI C63.10:2013

Test Result : Complied

Performing Lab. : A Test Lab Techno Corp.
No. 140-1, Changan Street, Bade District,
Taoyuan City 334025, Taiwan (R.O.C.)
Tel : +886-3-2710188 / Fax : +886-3-2710190
Taiwan Accreditation Foundation accreditation number: 1330



A Test Lab Techno Corp. tested the above equipment in accordance with the requirements set forth in the above standards. All indications of Pass/Fail in this report are opinions expressed by A Test Lab Techno Corp. based on interpretations and/or observations of test results. The test results show that the equipment tested is capable of demonstrating compliance with the requirements as documented in this report.

Approved By :

(Kai Yu Yang)

TABLE OF CONTENTS

| | | |
|----------|---|-----------|
| 1 | EUT Description..... | 5 |
| 2 | Test Methodology..... | 7 |
| 3 | Dynamic Frequency Selection..... | 8 |
| | 3.1. Limits | 8 |
| | 3.2. Test and Measurement System | 12 |
| | 3.3. Test Instruments | 14 |
| 4 | Test Methodology..... | 15 |
| | 4.1. Mode of Operation..... | 15 |
| | 4.2. EUT Test Step..... | 15 |
| | 4.3. Test Site Environment..... | 15 |
| 5 | Test Results | 16 |
| | 5.1. Channel Availability Check Time..... | 16 |
| | 5.2. Channel Move Time and Channel Closing Transmission Time..... | 16 |
| | 5.3. Non-Occupancy Period | 17 |
| | 5.4. U-NII Detection Bandwidth | 17 |
| | 5.5. Statistical Performance check | 17 |
| | 5.6. Channel Loading | 18 |

Appendix A. Test Result

Appendix B. Test Setup Photographs

1 EUT Description

| | | | | |
|---------------------|--|----------------|-----------------------|--------------------|
| Applicant | Kaonbroadband CO., LTD 884-3, Seongnam-daero, Bundang-gu, Seongnam-si, Gyeonggi-do, Republic of Korea | | | |
| Product Name | WiFi6E XGS-PON Gateway | | | |
| Trade Name | KAON | | | |
| Model Number | PG2494 | | | |
| FCC ID | 2AXCW-PG2494 | | | |
| Operate Frequency | Frequency Band | | Frequency Range (MHz) | Number of Channels |
| | IEEE 802.11a | U-NII Band 2-A | 5260 – 5320 | 3 |
| | | U-NII Band 2-C | 5500 – 5700 | 3 |
| | | Straddle band | 5720 | 1 |
| | IEEE 802.11n 5 GHz 20 MHz / IEEE 802.11ac 20 MHz/ IEEE 802.11ax 20 MHz | U-NII Band 2-A | 5260 – 5320 | 3 |
| | | U-NII Band 2-C | 5500 – 5700 | 3 |
| | | Straddle band | 5720 | 1 |
| | IEEE 802.11n 5 GHz 40 MHz / IEEE 802.11ac 40 MHz/ IEEE 802.11ax 40 MHz | U-NII Band 2-A | 5270 – 5310 | 2 |
| | | U-NII Band 2-C | 5510 – 5670 | 3 |
| | | Straddle band | 5710 | 1 |
| | IEEE 802.11ac 80 MHz/ IEEE 802.11ax 80 MHz | U-NII Band 2-A | 5290 | 1 |
| | | U-NII Band 2-C | 5530 – 5610 | 2 |
| Straddle band | | 5690 | 1 | |
| Modulation Type | OFDM/OFDMA | | | |
| Antenna information | ANT | Model Number | Type | Max. Gain (dBi) |
| | ANT-3 | SW25DEC100P | Internal PCB Antenna | 2.0 |
| | ANT-0/1/2 | SW25DEC200P | Internal PCB Antenna | 2.0 |
| Antenna Delivery | IEEE 802.11a : 4TX (CDD) IEEE 802.11n / ac /ax :4TX (CDD/Beamforming on) | | | |
| Operate Temp. Range | 0 ~ 40 °C | | | |
| EUT Power Rating | DC 12 V, 3.33 A | | | |

| Items | Description | |
|--------------------------------|---|--|
| Communication Mode | <input checked="" type="checkbox"/> IP Based (Load Based) | <input type="checkbox"/> Frame Based |
| TPC Function | <input checked="" type="checkbox"/> With TPC | <input type="checkbox"/> Without TPC |
| Weather Band (5600 ~ 5650 MHz) | <input checked="" type="checkbox"/> With 5600 ~ 5650 MHz | <input type="checkbox"/> Without 5600 ~ 5650 MHz |
| Beamforming Function | <input checked="" type="checkbox"/> With Beamforming | <input type="checkbox"/> Without Beamforming |
| Equipment Type | <input type="checkbox"/> Outdoor access point (point-to-point) | |
| | <input type="checkbox"/> Outdoor access point (point-to-multipoint) | |
| | <input checked="" type="checkbox"/> Indoor access point | |
| | <input type="checkbox"/> Fixed point-to-point access points | |
| | <input type="checkbox"/> Client devices | |
| Operating mode | <input checked="" type="checkbox"/> Master | |
| | <input type="checkbox"/> Client with radar detection | |
| | <input type="checkbox"/> Client without radar detection | |
| | <input type="checkbox"/> Ad-Hoc | |
| | <input type="checkbox"/> Bridge | |
| | <input type="checkbox"/> MESH | |

Note : DFS controls (hardware or software) related to radar detection are NOT accessible to the user.

Manufacturer statement confirming that information regarding the parameters of the detected Radar Waveforms is not available to the end user.

2 Test Methodology

The tests documented in this report were performed in accordance with ANSI C63.10-2013, FCC CFR 47 Part 2, FCC CFR 47 Part 15.

The tests documented in this report were performed in accordance with FCC KDB request:

- FCC KDB 905462 D02 UNII DFS Compliance Procedures New Rules v02
- FCC KDB 905462 D03 UNII Clients Without Radar Detection New Rules v01r02

3 Dynamic Frequency Selection

3.1. Limits

§15.407 (h) and FCC KDB 905462 D02 UNII DFS Compliance Procedures New Rules v02 Compliance measurement procedures for unlicensed-national information infrastructure devcies operating in the 5250-5350 MHZ and 5470-5725 MHZ bands incorporating dynamic frequency selection.

| Table 1: Applicability of DFS Requirements Prior to Use of a Channel | | | |
|---|------------------|----------------------------------|-------------------------------|
| Requirement | Operational Mode | | |
| | Master | Client (without Radar Detection) | Client (with Radar Detection) |
| Non-Occupancy Period | Yes | Not required | Yes |
| DFS Detection Threshold | Yes | Not required | Yes |
| Channel Availability Check Time | Yes | Not required | Not required |
| U-NII Detection Bandwidth | Yes | Not required | Yes |

| Table 2: Applicability of DFS requirements during normal operation | | |
|---|--|--------------------------------|
| Requirement | Operational Mode | |
| | Master Device or Client With Radar Detection | Client without Radar Detection |
| DFS Detection Threshold | Yes | Not required |
| Channel Closing Transmission Time | Yes | Yes |
| Channel Move Time | Yes | Yes |
| U-NII Detection Bandwidth | Yes | Not required |

| Additional requirements for devices with multiple bandwidth modes | Master Device or Client With Radar Detection | Client without Radar Detection |
|---|--|--|
| U-NII Detection Bandwidth and Statistical Performance Check | All BW modes must be tested | Not required |
| Channel Move Time and Channel Closing Transmission Time | Test using widest BW mode available | Test using the widest BW mode available for the link |
| All other tests | Any single BW mode | Not required |

Note : Frequencies selected for statistical performance check (Section 7.8.4) should include several frequencies within the radar detection bandwidth and frequencies near the edge of the radar detection bandwidth. For 802.11 devices it is suggested to select frequencies in all 20 MHz channel blocks and a null frequencies between the bonded 20 MHz channel blocks

| Table 3: DFS Detection Thresholds for Master Devices and Client Devices With Radar Detection | |
|---|--|
| Maximum Transmit Power | U-NII Band 2-Aalue (See Notes 1,2 and 3) |
| EIRP \geq 200 milliwatt | -64 dBm |
| EIRP < 200 milliwatt and Power spectral density < 10 dBm/MHz | -62 dBm |
| EIRP < 200 milliwatt that do not meet the power spectral density requirement | -64 dBm |
| <p>Note 1: This is the level at the input of the receiver assuming a 0 dBi receive antenna.</p> <p>Note 2: Throughout these test procedures an additional 1 dB has been added to the amplitude of the test transmission waveforms to account for variations in measurement equipment. This will ensure that the test signal is at or above the detection threshold level to trigger a DFS response.</p> <p>Note 3: EIRP is based on the highest antenna gain. For MIMO devices refer to FCC KDB Publication 662911 D01.</p> | |

| Table 4: DFS Response Requirement U-NII Band 2-Aalues | |
|---|--|
| Parameter | U-NII Band 2-Aalue |
| Non-occupancy period | Minimum 30 minutes |
| Channel Availability Check Time | 60 seconds |
| Channel Move Time | 10 seconds See Note 1. |
| Channel Closing Transmission Time | 200 milliseconds + an aggregate of 60 milliseconds over remaining 10 second period. See Notes 1 and 2. |
| U-NII Detection Bandwidth | Minimum 100 % of the U-NII 99 % transmission power bandwidth. See Note 3. |
| <p>Note 1: Channel Move Time and the Channel Closing Transmission Time should be performed with Radar Type 0. The measurement timing begins at the end of the Radar Type 0 burst.</p> <p>Note 2: The Channel Closing Transmission Time is comprised of 200 milliseconds starting at the beginning of the Channel Move Time plus any additional intermittent control signals required to facilitate a Channel move (an aggregate of 60 milliseconds) during the remainder of the 10 second period. The aggregate duration of control signals will not count quiet periods in between transmissions.</p> <p>Note 3: During the U-NII Detection Bandwidth detection test, radar type 0 should be used. For each frequency step the minimum percentage of detection is 90 percent. Measurements are performed with no data traffic.</p> | |

| Table 5: Short Pulse Radar Test Waveforms | | | | | |
|--|--------------------|--|--|--|--------------------------|
| Radar Type | Pulse Width (μsec) | PRI (μsec) | Number of Pulses | Minimum Percentage of Successful Detection | Minimum Number of Trials |
| 0 | 1 | 1428 | 18 | See Note 1 | See Note 1 |
| 1 | 1 | Test A: 15 unique PRI values randomly selected from the list of 23 PRI values in Table 5a <hr/> Test B: 15 unique PRI values randomly selected within the range of 518-3066 μsec, with a minimum increment of 1 μsec, excluding PRI values selected in Test A | $\text{Roundup} \left\{ \begin{array}{l} \left(\frac{1}{360} \right) \cdot \\ \left(\frac{19 \cdot 10^6}{\text{PRI}_{\mu\text{sec}}} \right) \end{array} \right\}$ | 60 % | 30 |
| 2 | 1-5 | 150-230 | 23-29 | 60 % | 30 |
| 3 | 6-10 | 200-500 | 16-18 | 60 % | 30 |
| 4 | 11-20 | 200-500 | 12-16 | 60 % | 30 |
| Aggregate (Radar Types 1-4) | | | | 80 % | 120 |
| Note 1: Short Pulse Radar Type 0 should be used for the detection bandwidth test, channel move time, and channel closing time tests. | | | | | |

| Table 5a: Pulse Repetition Intervals U-NII Band 2-Aalues for Test A | | |
|---|--|--|
| Pulse Repetition Frequency Number | Pulse Repetition Frequency (Pulses Per Second) | Pulse Repetition Interval (Microseconds) |
| 1 | 1930.5 | 518 |
| 2 | 1858.7 | 538 |
| 3 | 1792.1 | 558 |
| 4 | 1730.1 | 578 |
| 5 | 1672.2 | 598 |
| 6 | 1618.1 | 618 |
| 7 | 1567.4 | 638 |
| 8 | 1519.8 | 658 |
| 9 | 1474.9 | 678 |
| 10 | 1432.7 | 698 |
| 11 | 1392.8 | 718 |
| 12 | 1355 | 738 |
| 13 | 1319.3 | 758 |
| 14 | 1285.3 | 778 |
| 15 | 1253.1 | 798 |
| 16 | 1222.5 | 818 |
| 17 | 1193.3 | 838 |
| 18 | 1165.6 | 858 |
| 19 | 1139 | 878 |
| 20 | 1113.6 | 898 |
| 21 | 1089.3 | 918 |
| 22 | 1066.1 | 938 |
| 23 | 326.2 | 3066 |

| Table 6 – Long Pulse Radar Test Signal | | | | | | | |
|--|--------|------------------|--------------------|-------------------|------------|--|----------------|
| Radar Waveform | Bursts | Pulses per Burst | Pulse Width (µsec) | Chirp Width (MHz) | PRI (µsec) | Minimum Percentage of Successful Detection | Minimum Trials |
| 5 | 8-20 | 1-3 | 50-100 | 5-20 | 1000-2000 | 80 % | 30 |

| Table 7 – Frequency Hopping Radar Test Signal | | | | | | | |
|---|--------------------|------------|-------------------|----------------|--------------------|--|----------------|
| Radar Waveform | Pulse Width (µsec) | PRI (µsec) | Burst Length (ms) | Pulses per Hop | Hopping Rate (kHz) | Minimum Percentage of Successful Detection | Minimum Trials |
| 6 | 1 | 333 | 300 | 9 | 0.333 | 70 % | 30 |

3.2. Test and Measurement System

3.2.1. Setup for Master with injection at the Master

Example Radiated Setup where UUT is a Master and Radar Test Waveforms are injected into the Master

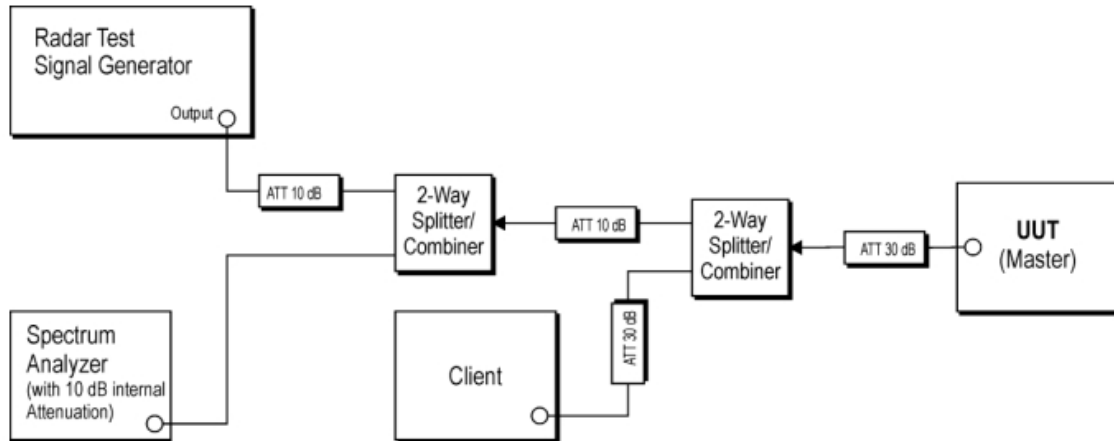

Tested System Details

The types for all equipments, plus descriptions of all cables used in the tested system (including inserted cards) are:

| | Product | Manufacturer | Model No. | ID |
|----|------------------------|--------------|-----------|--------------|
| 1. | WiFi6E XGS-PON Gateway | KAON | PG2494 | 2AXCW-PG2494 |

3.2.2. System Calibration

The short pulse types 0,1,2, 3 and 4, and the long pulse type 5 parameters are randomized at run-time. The hopping type 6 pulse parameters are fixed while the hopping sequence is based on the May 2014 NTIA Hopping Frequency List. The initial starting point randomized at run-time and each subsequent starting point is incremented by 475. Each frequency in the 100-length segment is compared to the boundaries of the EUT Detection Bandwidth and the software creates a hopping burst pattern in accordance with Section 7.4.1.3 Method #2 Simulated Frequency Hopping Radar Waveform Generating Subsystem of FCC KDB 905462 D02 UNII DFS Compliance Procedures New Rules v02 The frequency of the signal generator is incremented in 1 MHz steps from FL to FH for each successive trial. This incremental sequence is repeated as required to generate a minimum of 30 total trials and to maintain a uniform frequency distribution over the entire Detection Bandwidth.

The signal monitoring equipment consists of a spectrum analyzer. The aggregate ON time is calculated by multiplying the number of bins above a threshold during a particular observation period by the dwell time per bin, with the analyzer set to peak detection and max hold.

3.2.3. System Calibration

The Interference Radar Detection Threshold Level is (-63 dBm), The above equipment setup was used to calibrate the radiated Radar Waveform. A vector signal generator was utilized to establish the test signal level for each radar type. During this process there were replace 50 ohm terminal form Master and Client device and no transmissions by either the Master or Client Device. The spectrum analyzer was switched to the zero span (Time Domain) at the frequency of the Radar Waveform generator. Peak detection was used. The spectrum analyzer resolution bandwidth (RBW) and video bandwidth (U-NII Band 2-ABW) were set to at least 3 MHz.

The vector signal generator amplitude was set so that the power level measured at the spectrum analyzer was (-63 dBm). Capture the spectrum analyzer plots on short pulse radar types, long pulse radar type and hopping radar waveform.

3.2.4. Adjustment of Displayed Traffic Level

A link is established between the Master and Slave and the distance between the units is adjusted as needed to provide a suitable received level at the Master and Slave devices. Software to ping the client is permitted to simulate data transfer but must have random ping intervals. The monitoring antenna is adjusted so that the WLAN traffic level, as displayed on the spectrum analyzer, is at lower amplitude than the radar detection threshold.

3.3. Test Instruments

For Conducted

Test Period: May.12 ~ 13, 2022

Testing Engineer: Jeremy Lin

| Use | Equipment | Manufacturer | Model Number | Serial Number | Cal. Date | Cal. Period |
|-------------------------------------|---------------------------------------|--------------|--------------|---------------|---------------|-------------|
| <input type="checkbox"/> | Power Sensor | Anritsu | MA2411B | 1126022 | Sep. 03, 2021 | 1 year |
| <input type="checkbox"/> | Power Meter | Anritsu | ML2495A | 1135009 | Sep. 03, 2021 | 1 year |
| <input type="checkbox"/> | Power Sensor | Agilent | N1921A | MY45241957 | Dec. 06, 2021 | 1 year |
| <input type="checkbox"/> | Power Meter | Agilent | N1911A | MY45101619 | Dec. 06, 2021 | 1 year |
| <input type="checkbox"/> | Spectrum Analyzer (10 Hz~26.5 GHz) | Keysight | N9010B | MY59071418 | Mar. 16, 2022 | 1 year |
| <input type="checkbox"/> | Spectrum Analyzer (9 kHz~26.5 GHz) | Agilent | N9010A | MY48030518 | Jul. 23, 2021 | 1 year |
| <input type="checkbox"/> | Spectrum Analyzer (20 Hz~26.5 GHz) | Agilent | N9020A | US47520902 | Sep. 09, 2021 | 1 year |
| <input type="checkbox"/> | Spectrum Analyzer (3 Hz~50 GHz) | Agilent | N9030A | MY53120541 | Jan. 05, 2022 | 1 year |
| <input type="checkbox"/> | Temperature & Humidity Chamber | TAICHY | MHU-225LA | 980729 | Mar. 30, 2021 | 1 year |
| <input type="checkbox"/> | Signal Generator | Keysight | N5182B | MY53052569 | Apr. 20, 2021 | 1 year |
| <input type="checkbox"/> | Signal Generator | Keysight | N5182BX07 | MY59360221 | Apr. 20, 2021 | 1 year |
| <input type="checkbox"/> | Bluetooth Tester | R&S | CBT | 100350 | Mar. 17, 2021 | 2 years |
| <input type="checkbox"/> | Wireless Connectivity Tester | R&S | CMW270 | 102208 | Jun. 02, 2021 | 1 year |
| <input type="checkbox"/> | Power Supply | KEITHLEY | 2303 | 4045290 | Jan. 19, 2022 | 1 year |
| <input type="checkbox"/> | RF Communication Test Set | HP | 8920A | 3344A03297 | Aug. 10, 2021 | 1 year |
| <input checked="" type="checkbox"/> | Spectrum Analyzer | R&S | FSV3044 | 101255 | Dec. 20, 2021 | 1 year |
| <input checked="" type="checkbox"/> | Switch Box | R&S | OSP-B157W8 | 100850 | Dec. 20, 2021 | 1 year |
| <input checked="" type="checkbox"/> | Signal Generator | R&S | SMM100A | 101740 | Dec. 20, 2021 | 1 year |
| <input type="checkbox"/> | Signal Generator | R&S | SMB100A03 | 183027 | Dec. 20, 2021 | 1 year |

Note: N.C.R. = No Calibration Request.

4 Test Methodology

4.1. Mode of Operation

Decision of Test ATL has verified the construction and function in typical operation. All the test modes were carried out with the EUT in normal operation, which was shown in this test report and defined as:

| Test Mode |
|---|
| IEEE 802.11ax 20 MHz Continuous TX mode |
| IEEE 802.11ax 40 MHz Continuous TX mode |
| IEEE 802.11ax 80 MHz Continuous TX mode |

4.2. EUT Test Step

| | |
|----|--|
| 1. | Setup the EUT shown on 3.2. |
| 2. | Turn on the power of all equipment. |
| 3. | Turn on Wi-Fi function link to Access Point. |
| 4. | The EUT is operated in the normal mode to the purposes of measurement. |

4.3. Test Site Environment

| Items | Required (IEC 60068-1) | Actual |
|------------------|------------------------|--------|
| Temperature (°C) | 15-35 | 20-30 |
| Humidity (%RH) | 25-75 | 45-75 |

5 Test Results

5.1. Channel Availability Check Time

5.1.1. Procedure to Determine Initial Power-Up Cycle Time

A link was established on channel then the EUT was rebooted. The time from the cessation of traffic to the re-initialization of traffic was measured as the time required for the EUT to complete the total power-up cycle. The time to complete the initial power-up period is 60 seconds less than this total power-up time.

5.1.2. Procedure for Timing Of Radar Burst

With a link established on channel, the EUT was rebooted. A radar signal was triggered within 0 to 6 seconds after the initial power-up period, and transmissions on the channel were monitored on the spectrum analyzer.

The Non-Occupancy list was cleared. With a link established on channel, the EUT was rebooted. A radar signal was triggered within 54 to 60 seconds after the initial power-up period, and transmissions on the channel were monitored on the spectrum analyzer.

5.1.3. Test Results

See to the Appendix A

5.2. Channel Move Time and Channel Closing Transmission Time

5.2.1. Reporting Notes

The reference marker is set at the end of last radar pulse.

The delta marker is set at the end of the last WLAN transmission following the radar pulse.

This delta is the channel move time.

The aggregate channel closing transmission time is calculated as follows:

Aggregate Transmission Time = (Number of analyzer bins showing transmission) * (dwell time per bin)

The Channel Closing Transmission Time is comprised of 200 milliseconds starting at the beginning of the Channel Move Time plus any additional intermittent control signals required to facilitate a Channel move (an aggregate of 60 milliseconds) during the remainder of the 10 second period. The aggregate duration of control signals will not count quiet periods in between transmissions.

5.2.2. Test Results

See to the Appendix A

5.3. Non-Occupancy Period

5.3.1. Reporting Notes

Non-Occupancy Period time is 30 minute during which a Channel will not be utilized after a Radar Waveform is detected on that Channel.

5.3.2. Test Results

See to the Appendix A

5.4. U-NII Detection Bandwidth

5.4.1. Test Results

See to the Appendix A

5.5. Statistical Performance check

5.5.1. Test Results

See to the Appendix A

5.6. Channel Loading

■ Duty cycle $\geq 17\%$

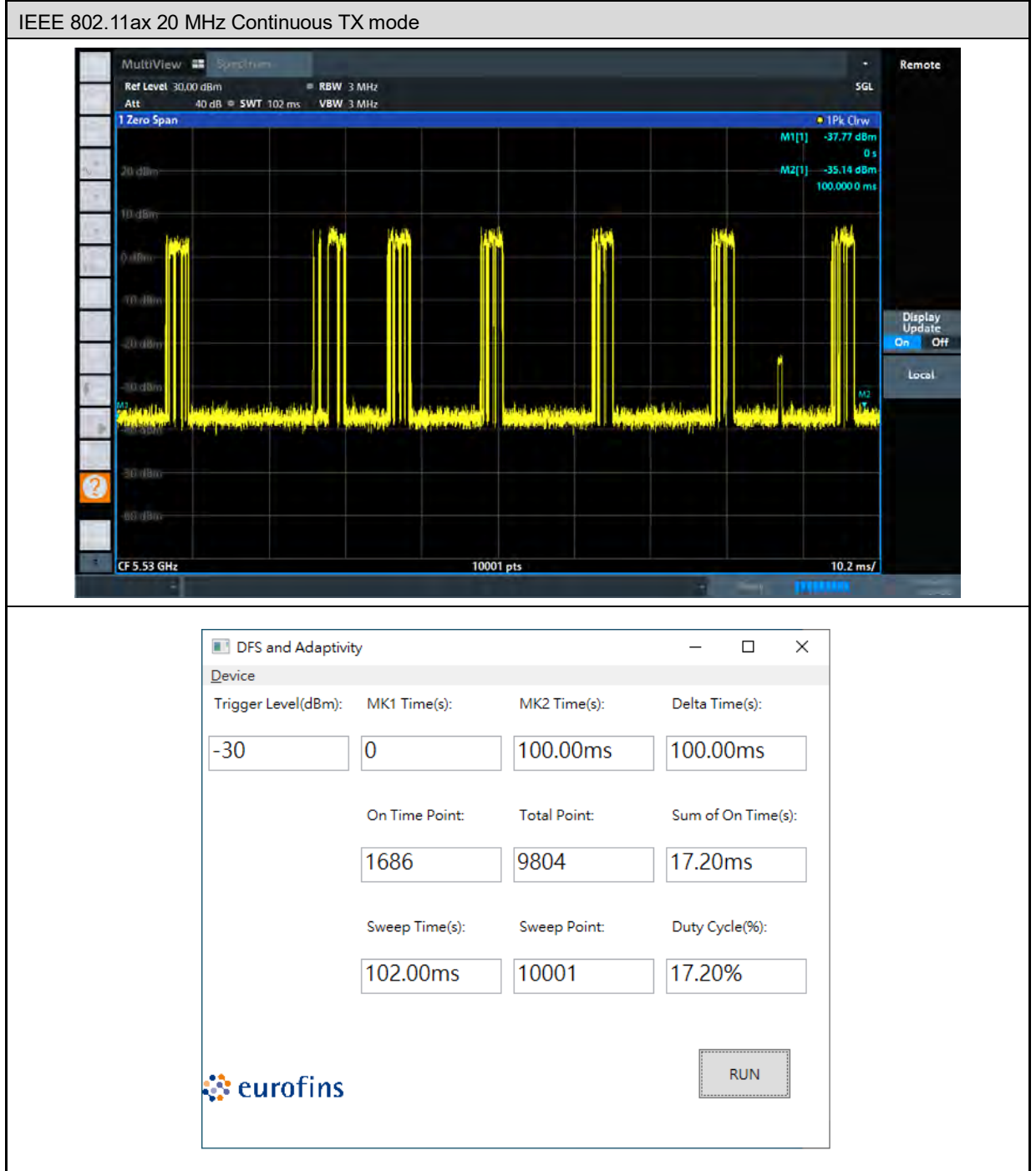

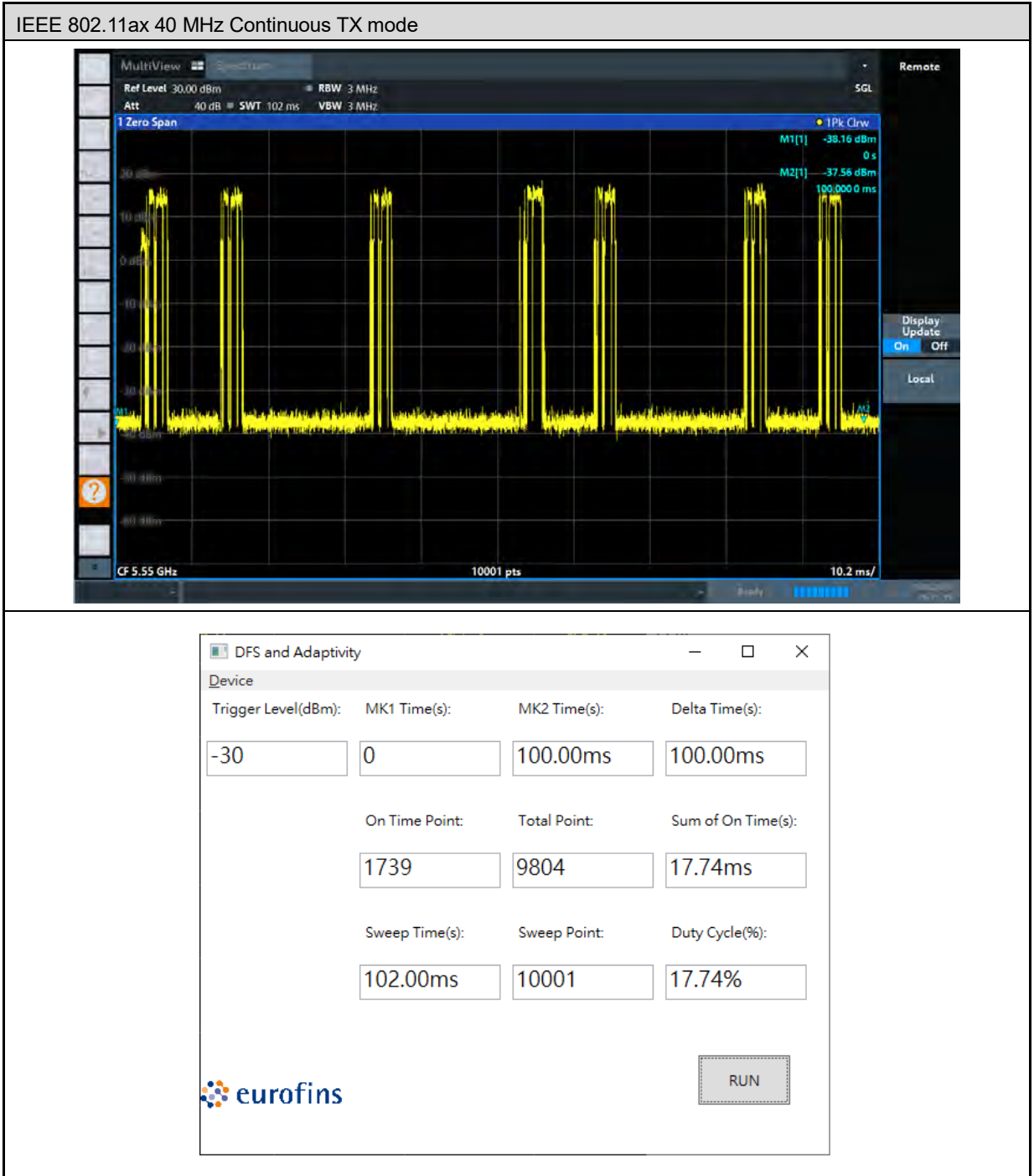

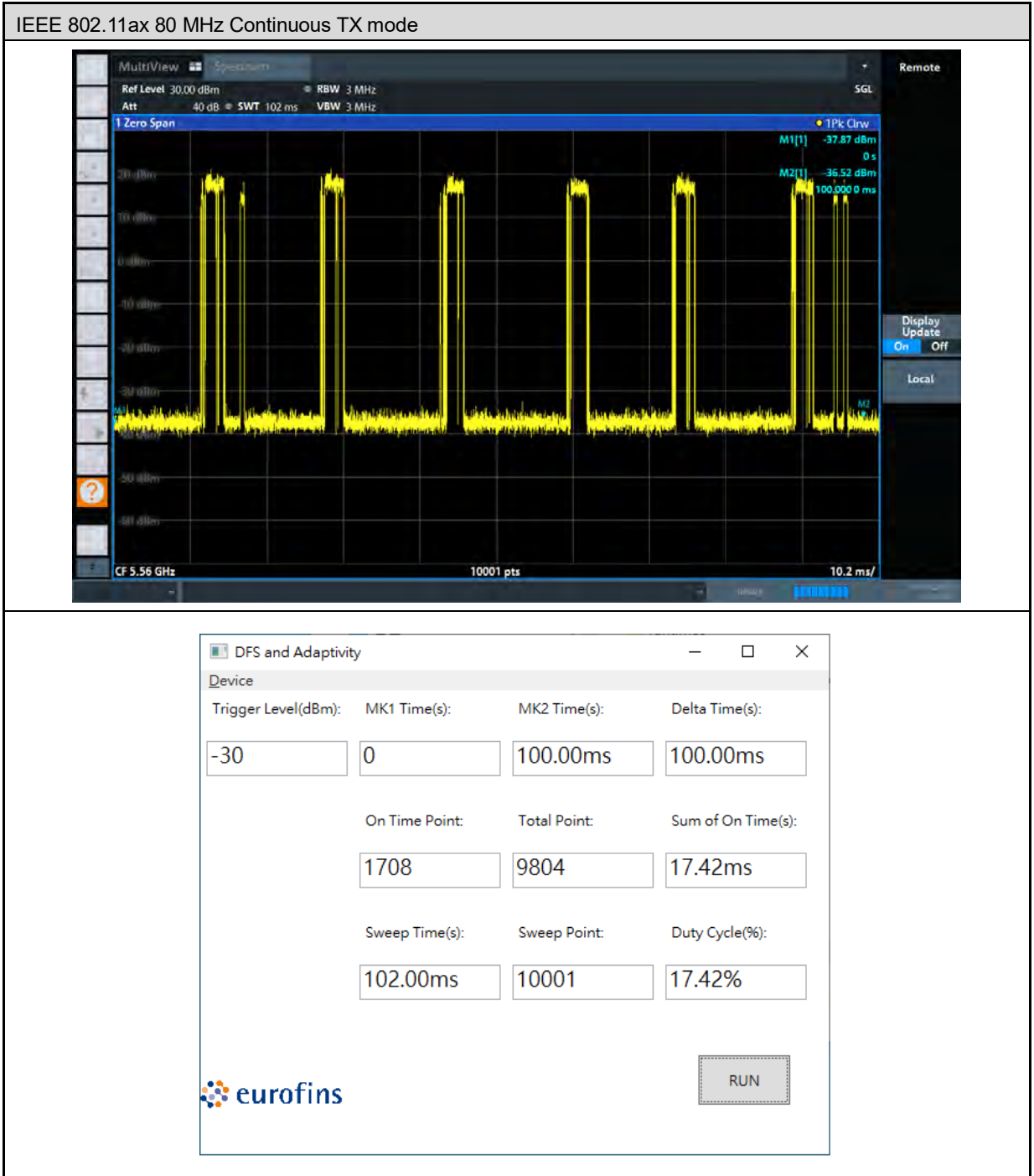

---END---