

RF Test Report

Applicant : Kaonbroadband CO., LTD

Product Name : WiFi6E XGS-PON Gateway

Trade Name : KAON

Model Number : PG2494

Applicable Standrd : FCC 47 CFR PART 15 SUBPART E
ANSI C63.10:2013

Received Date : Apr. 08, 2022

Test Period : Apr. 21 ~ Jun 23, 2022

Issued Date : Aug. 05, 2022

Issued by

A Test Lab Techno Corp.
No. 140-1, Changan Street, Bade District,
Taoyuan City 334025, Taiwan (R.O.C.)
Tel : +886-3-2710188 / Fax : +886-3-2710190



Taiwan Accreditation Foundation accreditation number: 1330
Frequency Range : 9 kHz to 40 GHz
Test Firm MRA designation number: TW0010

Note:

- 1.The test results are valid only for samples provided by customers and under the test conditions described in this report.
- 2.This report shall not be reproduced except in full, without the written approval of A Test Lab Technology Corporation.
- 3.The relevant information is provided by customers in this test report. According to the correctness, appropriateness or completeness of the information provided by the customer, if there is any doubt or error in the information which affects the validity of the test results, the laboratory does not take the responsibility.

Revision History

Rev.	Issued Date	Revisions	Revised By
00	Jul. 29, 2022	Initial Issue	Snow Wang
01	Aug. 05, 2022	Update report information (P.1) Update chapter 5.2 (P.311) Update chapter 5.3 (P.433)	Snow Wang

Verification of Compliance

Applicant : Kaonbroadband CO., LTD

Product Name : WiFi6E XGS-PON Gateway

Trade Name : KAON

Model Number : PG2494

FCC ID : 2AXCW-PG2494

Applicable Standard : FCC 47 CFR PART 15 SUBPART E
ANSI C63.10:2013

Test Result : Complied

Performing Lab. : A Test Lab Techno Corp.
No. 140-1, Changan Street, Bade District,
Taoyuan City 334025, Taiwan (R.O.C.)
Tel : +886-3-2710188 / Fax : +886-3-2710190
Taiwan Accreditation Foundation accreditation number: 1330



A Test Lab Techno Corp. tested the above equipment in accordance with the requirements set forth in the above standards. All indications of Pass/Fail in this report are opinions expressed by A Test Lab Techno Corp. based on interpretations and/or observations of test results. The test results show that the equipment tested is capable of demonstrating compliance with the requirements as documented in this report.

Approved By : _____
(Kai Yu Yang)

TABLE OF CONTENTS

1	General Information	5
	1.1. Summary of Test Result.....	5
	1.2. Measurement Uncertainty.....	6
2	EUT Description	7
3	Test Methodology.....	10
	3.1. Mode of Operation.....	10
	3.2. EUT Test Step.....	12
	3.3. Configuration of Test System Details	13
	3.4. Test Instruments	14
	3.5. Test Site Environment.....	16
4	Measurement Procedure.....	17
	4.1. AC Power Conducted Emission Measurement	17
	4.2. Transmitter Radiated Emissions Measurement.....	19
	4.3. Maximum Conducted Output Power and Transmit power control Measurement	24
	4.4. 26 dB RF Bandwidth Measurement	25
	4.5. 6 dB RF Bandwidth Measurement	26
	4.6. Maximum Power Spectral Density Measurement.....	27
	4.7. Automatically discontinue transmission.....	29
	4.8. Antenna Requirement.....	29
5	Test Results.....	32
	5.1. Conducted Emission.....	32
	5.2. Radiated Emission Measurement	34
	5.3. Conducted Test Results	356

Appendix A. Test Setup Photographs

1 General Information

1.1. Summary of Test Result

Standard	Item	Result	Remark
15.407(b)(9) 15.207	AC Power Conducted Emission	PASS	---
15.407(b) 15.205 / 15.209	Transmitter Radiated Emissions	PASS	---
15.407(a)	Maximum Conducted Output Power	PASS	---
15.407(a)	26 dB RF Bandwidth	Reference	---
15.407(e)	6 dB RF Bandwidth	PASS	---
15.407(a)	Maximum Power Spectral Density	PASS	---
15.407(c)	Automatically discontinue transmission	PASS	---
15.407(a) 15.203	Antenna Requirement	PASS	---

Decision Rule

- Uncertainty is not included.
- Uncertainty is included.

Standard	Description
CFR47, Part 15, Subpart C	Intentional Radiators
CFR47, Part 15, Subpart E	Unlicensed National Information Infrastructure Devices
ANSI C63. 10: 2013	American National Standard of Procedures for Compliance Testing of Unlicensed Wireless Devices
KDB789033: D02	Guidelines for Compliance Testing of Unlicensed National Information Infrastructure (U-NII) Devices Part 15, Subpart E
KDB 662911 D01 v02r01	Emissions Testing of Transmitters with Multiple Outputs in the Same Band (e.g., MIMO, Smart Antenna, etc)

1.2. Measurement Uncertainty

Test Item	Frequency Range	Uncertainty
Conducted Emission	150 kHz ~ 30 MHz	2.7 dB
Radiated Emission	9 kHz ~ 30 MHz	2.2 dB
	30 MHz ~ 1000 MHz	5.1 dB
	1000 MHz ~ 18000 MHz	5.2 dB
	18000 MHz ~ 26500 MHz	4.6 dB
	26500 MHz ~ 40000 MHz	4.6 dB
Conducted Output Power		1.1 dB
RF Bandwidth		4.7 %
Power Spectral Density		1.1 dB
Frequency Stability		1.3×10^{-7}
Duty Cycle		1.1 %
Time Occupancy		1.5 %

2 EUT Description

Applicant	Kaonbroadband CO., LTD 884-3, Seongnam-daero, Bundang-gu, Seongnam-si, Gyeonggi-do, Republic of Korea			
Product Name	WiFi6E XGS-PON Gateway			
Trade Name	KAON			
Model Number	PG2494			
FCC ID	2AXCW-PG2494			
Operate Frequency	Frequency Band		Frequency Range (MHz)	Number of Channels
	IEEE 802.11a	U-NII Band 1	5180 – 5240	3
		U-NII Band 2-A	5260 – 5320	3
		U-NII Band 2-C	5500 – 5700	3
		Straddle band	5720	1
		U-NII Band 3	5745 – 5825	3
	IEEE 802.11n 5 GHz 20 MHz / IEEE 802.11ac 20 MHz/ IEEE 802.11ax 20 MHz	U-NII Band 1	5180 – 5240	3
		U-NII Band 2-A	5260 – 5320	3
		U-NII Band 2-C	5500 – 5700	3
		Straddle band	5720	1
		U-NII Band 3	5745 – 5825	3
	IEEE 802.11n 5 GHz 40 MHz / IEEE 802.11ac 40 MHz/ IEEE 802.11ax 40 MHz	U-NII Band 1	5190 – 5230	2
		U-NII Band 2-A	5270 – 5310	2
		U-NII Band 2-C	5510 – 5670	3
		Straddle band	5710	1
		U-NII Band 3	5755 – 5795	2
	IEEE 802.11ac 80 MHz/ IEEE 802.11ax 80 MHz	U-NII Band 1	5210	1
		U-NII Band 2-A	5290	1
		U-NII Band 2-C	5530 – 5610	2
		Straddle band	5690	1
U-NII Band 3		5775	1	
Modulation Type	OFDM/OFDMA			

Antenna information	Antenna	Model	Type	Max. Gain (dBi)
	ANT-3	SW25DEC100P	Internal PCB Antenna	2.0
	ANT-0/1/2	SW25DEC200P	Internal PCB Antenna	2.0
Antenna Delivery	Reference section 3.1			
Operate Temp. Range	0 ~ 40 °C			
EUT Power Rating	DC 12 V, 3.33 A			

EUT Modify Description :

<p>Modify Description: Add DFS bands, Straddle Channel and IEEE 802.11ax Partial RU via software and there is no hardware changes or modifications.</p>
FCC ID: 2AXCW-PG2494

Frequency Band	RF Output Power (W)	
IEEE 802.11a	U-NII Band 2-A	0.126
	U-NII Band 2-C	0.114
IEEE 802.11n 5 GHz 20 MHz	U-NII Band 2-A	0.119
	U-NII Band 2-C	0.094
IEEE 802.11n 5 GHz 40 MHz	U-NII Band 2-A	0.097
	U-NII Band 2-C	0.160
IEEE 802.11ac 20 MHz	U-NII Band 2-A	0.116
	U-NII Band 2-C	0.120
IEEE 802.11ac 40 MHz	U-NII Band 2-A	0.097
	U-NII Band 2-C	0.204
IEEE 802.11ac 80 MHz	U-NII Band 2-A	0.079
	U-NII Band 2-C	0.216
IEEE 802.11ax 20 MHz	U-NII Band 2-A	0.123
	U-NII Band 2-C	0.122
IEEE 802.11ax 40 MHz	U-NII Band 2-A	0.108
	U-NII Band 2-C	0.212
IEEE 802.11ax 80 MHz	U-NII Band 2-A	0.083
	U-NII Band 2-C	0.224

Beamforming on

Frequency Band		RF Output Power (W)
IEEE 802.11n 5 GHz 20 MHz	U-NII Band 2-A	0.118
	U-NII Band 2-C	0.094
IEEE 802.11n 5 GHz 40 MHz	U-NII Band 2-A	0.096
	U-NII Band 2-C	0.158
IEEE 802.11ac 20 MHz	U-NII Band 2-A	0.115
	U-NII Band 2-C	0.118
IEEE 802.11ac 40 MHz	U-NII Band 2-A	0.095
	U-NII Band 2-C	0.200
IEEE 802.11ac 80 MHz	U-NII Band 2-A	0.078
	U-NII Band 2-C	0.211
IEEE 802.11ax 20 MHz	U-NII Band 2-A	0.122
	U-NII Band 2-C	0.119
IEEE 802.11ax 40 MHz	U-NII Band 2-A	0.107
	U-NII Band 2-C	0.209
IEEE 802.11ax 80 MHz	U-NII Band 2-A	0.082
	U-NII Band 2-C	0.222

Equipment Type

Outdoor access point	point-to-point	---
	point-to-multipoint	---
Indoor access point		V
Fixed point-to-point access points		---
Client devices		---

3 Test Methodology

3.1. Mode of Operation

Decision of Test ATL has verified the construction and function in typical operation. All the test modes were carried out with the EUT in normal operation, which was shown in this test report and defined as:

Test Mode
Mode 1: Transmit mode
Mode 2: IEEE 802.11a Continuous TX Mode
Mode 3: IEEE 802.11n 5 GHz 20 MHz Continuous TX Mode
Mode 4: IEEE 802.11n 5 GHz 40 MHz Continuous TX Mode
Mode 5: IEEE 802.11ac 20 MHz Continuous TX Mode
Mode 6: IEEE 802.11ac 40 MHz Continuous TX Mode
Mode 7 IEEE 802.11ac 80 MHz Continuous TX Mode
Mode 8: IEEE 802.11ax 20 MHz Continuous TX Mode
Mode 9: IEEE 802.11ax 40 MHz Continuous TX Mode
Mode 10: IEEE 802.11ax 80 MHz Continuous TX Mode

Final-Test Mode
Mode 1: Transmit mode
Mode 2: IEEE 802.11a Continuous TX mode
Mode 8: IEEE 802.11ax 20 MHz Continuous TX Mode
Mode 9: IEEE 802.11ax 40 MHz Continuous TX Mode
Mode 10: IEEE 802.11ax 80 MHz Continuous TX Mode

Software used to control the EUT for staying in continuous transmitting mode was programmed.

After verification, all tests were carried out with the worst case test modes.

Note 1: This product supports normal mode and Beamforming on mode. According to power table, the normal mode is worst power. So, normal mode has to test and record results for Conducted.

Note 2: Investigation has been done on all the possible configurations for searching the worst cases (HE20/HE40/HE80 covers HT20/HT40/VHT20/VHT40/VHT80). The table is a list of the test modes show in this test report.

Note 3: Investigation has been done on all the possible configurations for searching the worst cases (IEEE 802.11ax test results Full RU Covers Partial RU).

Test Mode	ANT-0	ANT-1	ANT-2	ANT-3	ANT-0+1+2+3
Mode 2	V	V	V	V	V
Mode 3	V	V	V	V	V
Mode 4	V	V	V	V	V
Mode 5	V	V	V	V	V
Mode 6	V	V	V	V	V
Mode 7	V	V	V	V	V
Mode 8	V	V	V	V	V
Mode 9	V	V	V	V	V
Mode 10	V	V	V	V	V

Test Mode	Antenna Delivery	Data Rate (Mbps)	Band	Test Channel
Mode 2	4TX (CDD)	6	U-NII Band 2-A	52, 56, 64
			U-NII Band 2-C	100, 112, 140, 144
Mode 3	4TX (CDD/Beamforming on)	26	U-NII Band 2-A	52, 56, 64
			U-NII Band 2-C	100, 112, 140, 144
Mode 4	4TX (CDD/Beamforming on)	54	U-NII Band 2-A	54, 62
			U-NII Band 2-C	102, 110, 134, 142
Mode 5	4TX (CDD/Beamforming on)	26	U-NII Band 2-A	52, 56, 64
			U-NII Band 2-C	100, 112, 140, 144
Mode 6	4TX (CDD/Beamforming on)	54	U-NII Band 2-A	54, 62
			U-NII Band 2-C	102, 110, 134, 142
Mode 7	4TX (CDD/Beamforming on)	117.2	U-NII Band 2-A	58
			U-NII Band 2-C	106, 122, 138
Mode 8	4TX (CDD/Beamforming on)	MCS0	U-NII Band 2-A	52, 56, 64
			U-NII Band 2-C	100, 112, 140, 144
Mode 9	4TX (CDD/Beamforming on)	MCS0	U-NII Band 2-A	54, 62
			U-NII Band 2-C	102, 110, 134, 142
Mode 10	4TX (CDD/Beamforming on)	MCS0	U-NII Band 2-A	58
			U-NII Band 2-C	106, 122, 138

3.2. EUT Test Step

The EUT is operated in the engineering mode to fix the TX frequency for the purposes of measurement. According to its specifications, the EUT must comply with the requirements of Section 15.407 under the FCC Rules Part 15 Subpart E.

1.	Setup the EUT shown on "Configuration of Test System Details".
2.	Turn on the power of all equipment.
3.	Turn on TX function.
4.	EUT run test program.

3.3. Configuration of Test System Details

Conduction Emission

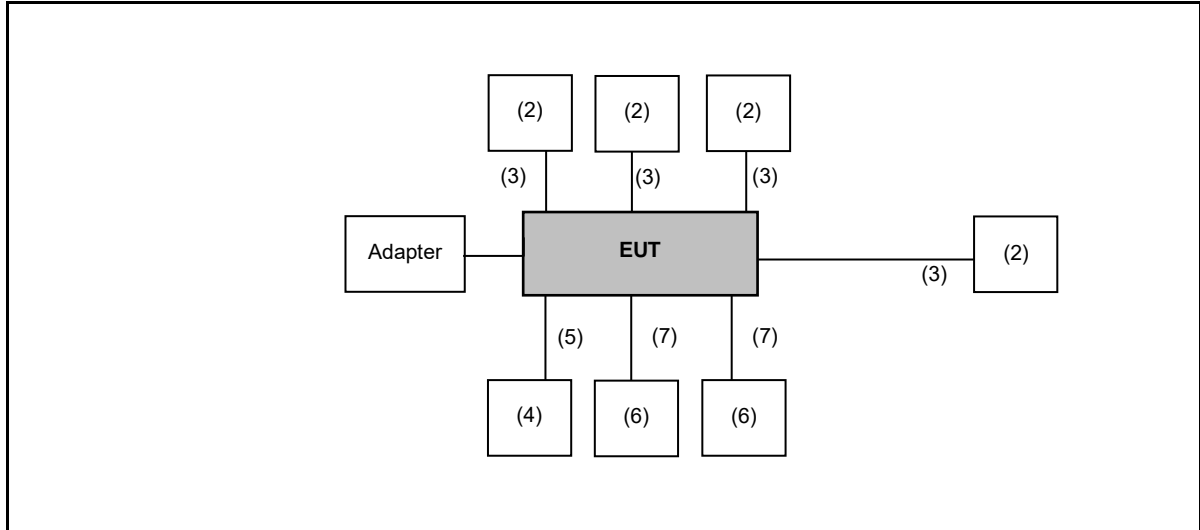

Radiated Emission

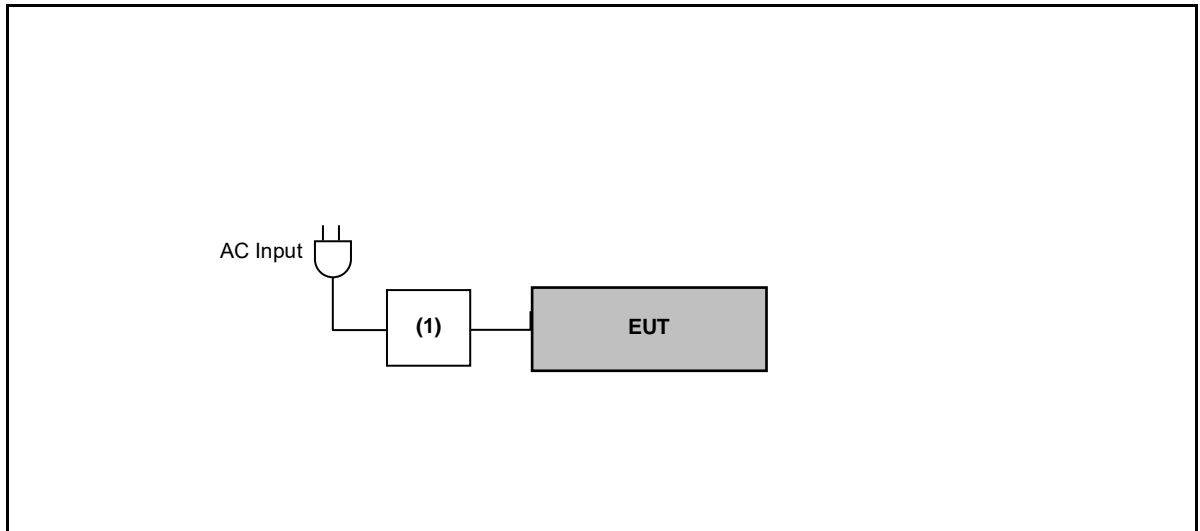

Devices Description					
	Product	Manufacturer	Model Number	Serial Number	Power Cord
(1)	Notebook	ASUS	UX410UQ	---	---
(2)	Notebook	ASUS	P1448U	---	---
(3)	LAN Cable	TATUNG	CAT6E	---	---
(4)	HDD	Transcend	TS1TSJ25A3K-RU	---	---
(5)	USB Cable	Transcend	TS1TSJ25A3K-RU	---	---
(6)	Telephone	TENDEL	K-762	---	---
(7)	RJ11	TENDEL	K-762	---	---

3.4. Test Instruments

For Conducted Emission
 Test Period: May 14, 2022
 Testing Engineer: Chi Chang

Use	Equipment	Manufacturer	Model Number	Serial Number	Cal. Date	Cal. Period
<input checked="" type="checkbox"/>	Test Receiver	R&S	ESCI	100367	May 21, 2021	1 year
<input type="checkbox"/>	Test Receiver	R&S	ESCI	100722	Nov. 02, 2021	1 year
<input type="checkbox"/>	Test Receiver	R&S	ESCI	101000	Nov. 26, 2021	1 year
<input checked="" type="checkbox"/>	LISN	R&S	ENV216	101040	Apr. 06, 2022	1 year
<input checked="" type="checkbox"/>	LISN	R&S	ENV216	101041	Apr. 15, 2022	1 year
<input checked="" type="checkbox"/>	RF Cable	Woken	00100D1380194M	TE-02-03	May 28, 2021	1 year
<input checked="" type="checkbox"/>	Software	EZ EMC	1.1.4.3	N/A	N.C.R.	---

For Conducted
 Test Period: Apr. 28 ~ Jun 23, 2022
 Testing Engineer: Brian Lin

Use	Equipment	Manufacturer	Model Number	Serial Number	Cal. Date	Cal. Period
<input checked="" type="checkbox"/>	Power Sensor	Anritsu	MA2411B	1126022	Sep. 03, 2021	1 year
<input checked="" type="checkbox"/>	Power Meter	Anritsu	ML2495A	1135009	Sep. 03, 2021	1 year
<input type="checkbox"/>	Power Sensor	Agilent	N1921A	MY45241957	Dec. 06, 2021	1 year
<input type="checkbox"/>	Power Meter	Agilent	N1911A	MY45101619	Dec. 06, 2021	1 year
<input type="checkbox"/>	Spectrum Analyzer (10 Hz~26.5 GHz)	Keysight	N9010B	MY59071418	Mar. 16, 2022	1 year
<input checked="" type="checkbox"/>	Spectrum Analyzer (9 kHz~26.5 GHz)	Agilent	N9010A	MY48030518	Jul. 23, 2021	1 year
<input type="checkbox"/>	Spectrum Analyzer (20 Hz~26.5 GHz)	Agilent	N9020A	US47520902	Sep. 09, 2021	1 year
<input type="checkbox"/>	Spectrum Analyzer (3 Hz~50 GHz)	Agilent	N9030A	MY53120541	Jan. 05, 2022	1 year
<input type="checkbox"/>	Temperature & Humidity Chamber	TAICHY	MHU-225LA	980729	Mar. 30, 2021	1 year
<input checked="" type="checkbox"/>	Signal Generator	Keysight	N5182B	MY53052569	Apr. 20, 2021	1 year
<input checked="" type="checkbox"/>	Signal Generator	Keysight	N5182BX07	MY59360221	Apr. 20, 2021	1 year
<input type="checkbox"/>	Bluetooth Tester	R&S	CBT	100350	Mar. 17, 2021	2 years
<input type="checkbox"/>	Wireless Connectivity Tester	R&S	CMW270	102208	Jun. 02, 2021	1 year
<input type="checkbox"/>	Power Supply	KEITHLEY	2303	4045290	Jan. 19, 2022	1 year
<input type="checkbox"/>	RF Communication Test Set	HP	8920A	3344A03297	Aug. 10, 2021	1 year

Note: N.C.R. = No Calibration Request.

For Radiated Emissions
 Test Period: Apr. 21 ~ Jun. 21, 2022
 Testing Engineer: Louis Shen, Marc Yeh

Radiation test sites		Semi Anechoic Room				
Use	Equipment	Manufacturer	Model Number	Serial Number	Cal. Date	Cal. Period
<input checked="" type="checkbox"/>	Spectrum Analyzer (10 Hz~44 GHz)	Keysight	N9010A	MY52221312	Jan. 13, 2022	1 year
<input type="checkbox"/>	Spectrum Analyzer (3 Hz~50 GHz)	Agilent	N9030A	MY53120541	Jan. 05, 2022	1 year
<input type="checkbox"/>	Amplifier (100 kHz~1.3 GHz)	Agilent	8447D	2944A11119	Jan. 14, 2022	1 year
<input type="checkbox"/>	Amplifier (100 kHz~1.3 GHz)	Agilent	8447D	2944A10961	Jul. 06, 2021	1 year
<input checked="" type="checkbox"/>	Preamplifier (10k Hz~3000 MHz)	EMCI	EMC001330	980862	Nov. 30, 2021	1 year
<input type="checkbox"/>	Amplifier (1 GHz~26.5 GHz)	Agilent	8449B	3008A02237	Oct. 21, 2021	1 year
<input checked="" type="checkbox"/>	Pre Amplifier (1~26.5 GHz)	Agilent	8449B	3008A02455	Jul. 12, 2021	1 year
<input type="checkbox"/>	Preamplifier (1 GHz~26.5 GHz)	EMCI	EMC012645SE	980289	Jan. 13, 2022	1 year
<input checked="" type="checkbox"/>	Preamplifier (26.5 GHz~40 GHz)	EMCI	EMC2654045	980028	Aug. 19, 2021	1 year
<input type="checkbox"/>	Loop Antenna (9 kHz~30 MHz)	COM-POWER CORPORATION	AL-130	121014	Apr. 07, 2021	1 year
<input type="checkbox"/>	Trilog Broadband Antenna (30 kHz~1 GHz)	Schwarzbeck Mess-Elektronik	VULB9168	01146	Jul. 19, 2021	1 year
<input type="checkbox"/>	Trilog Broadband Antenna (30 kHz~1 GHz)	Schwarzbeck Mess-Elektronik	VULB9168	416	Nov. 17, 2021	1 year
<input type="checkbox"/>	Broadband Horn Antenna (1 GHz~18 GHz)	Schwarzbeck Mess-Elektronik	9120D	02207	Jul. 09, 2021	1 year
<input checked="" type="checkbox"/>	Broadband Horn Antenna (1 GHz~18 GHz)	Schwarzbeck Mess-Elektronik	9120D	9120D-550	Aug. 24, 2021	1 year
<input checked="" type="checkbox"/>	Broadband Horn Antenna (18 GHz~40 GHz)	Schwarzbeck Mess-Elektronik	9170	9170-320	Aug. 24, 2021	1 year
<input type="checkbox"/>	Horn Antenna (18 GHz~40 GHz)	ETS	3116	00086467	Dec. 03, 2021	1 year
<input checked="" type="checkbox"/>	Microwave Cable	EMCI	EMC104-SM-SM- 13000	170814	Feb. 18, 2022	1 year
<input checked="" type="checkbox"/>	Microwave Cable	SUHNER	suflex104	313229/4	Fed. 18, 2022	1 year
<input type="checkbox"/>	Microwave Cable	EMCI	EMC102-KM-KM- 14000	151001	Feb. 18, 2022	1 year

Note: N.C.R. = No Calibration Request

Radiation test sites		Semi Anechoic Room				
Use	Equipment	Manufacturer	Model Number	Serial Number	Cal. Date	Cal. Period
<input checked="" type="checkbox"/>	Cable	EMCI	EMCCFD400-NM-NM-6000	210902	Feb. 18, 2022	1 year
<input type="checkbox"/>	RF Cable (30-1000 MHz)	EMCI	EMC104-N-N-2000	TE01-2	Feb. 18, 2022	1 year
<input type="checkbox"/>	RF Cable (30-1000 MHz)	EMCI	EMC104-N-N-6000	TE01-1	Feb. 18, 2022	1 year
<input type="checkbox"/>	RF Cable (30-1000 MHz)	EMCI	EMC106-SM-NM-1000	171219 (TE01-3)	Feb. 18, 2022	1 year
<input type="checkbox"/>	Bluetooth Tester	R&S	CBT	100350	Mar. 17, 2021	2 years
<input type="checkbox"/>	Wireless Connectivity Tester	R&S	CMW270	102208	Jun. 02, 2021	1 year
<input type="checkbox"/>	Power Supply	KEITHLEY	2303	4045290	Jan. 19, 2022	1 year
<input checked="" type="checkbox"/>	Software	EZ EMC	1.1.4.4	N/A	N.C.R.	---

Note: N.C.R. = No Calibration Request

3.5. Test Site Environment

Items	Required (IEC 60068-1)	Actual
Temperature (°C)	15-35	20-30
Humidity (%RH)	25-75	45-75

4 Measurement Procedure

4.1. AC Power Conducted Emission Measurement

■ Limit

Frequency (MHz)	Quasi-peak	Average
0.15 - 0.5	66 to 56	56 to 46
0.50 - 5.0	56	46
5.0 - 30.0	60	50

■ Test Setup

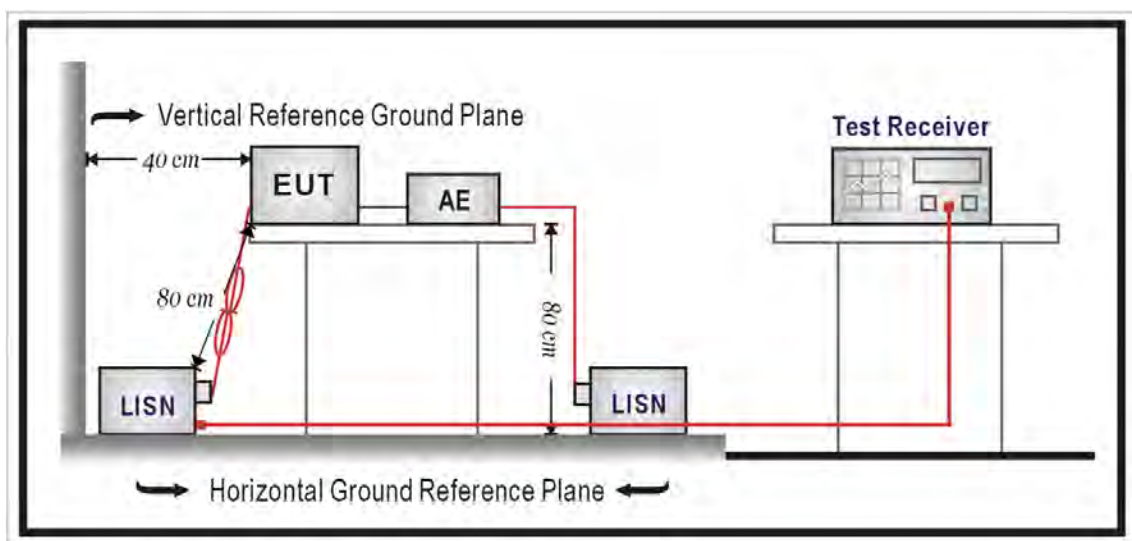

■ Test Procedure

The EUT and simulators are connected to the main power through a line impedance stabilization network (L.I.S.N.). This provides a $50 \Omega // 50 \mu\text{H}$ coupling impedance for the measuring equipment. The peripheral devices are also connected to the main power through a LISN that provides a $50 \Omega // 50 \mu\text{H}$ coupling impedance with 50 ohm termination.

Tabletop device shall be placed on a non-conducting platform, of nominal size 1 m by 1.5 m, raised 80 cm above the reference ground plane. The wall of screened room shall be located 40 cm to the rear of the EUT. Other surfaces of tabletop or floor standing EUT shall be at least 80 cm from any other ground conducting surface including one or more LISNs. For floor-standing device shall be placed under the EUT with a 12 mm insulating material.

Conducted emissions were investigated over the frequency range from 0.15 MHz to 30 MHz using a resolution bandwidth of 9 kHz. The equipment under test (EUT) shall be meet the limits in section 4.1, as applicable, including the average limit and the quasi-peak limit when using respectively, an average detector and quasi-peak detector measured in accordance with the methods described of related standard. When all of peak value were complied with quasi-peak and average limit from 150 kHz to 30 MHz then quasi-peak and average measurement was unnecessary.

The AMN shall be placed 0.8 m from the boundary of the unit under test and bonded to a ground reference plane for AMNs mounted on top of the ground reference plane. This distance is between the closest points of the AMN and the EUT. All other units of the EUT and associated equipment shall be at least 0.8 m from the AMN. If the mains power cable is longer than 1 m then the cable shall be folded back and forth at the centre of the lead to form a bundle no longer than 0.4 m. All of interconnecting cables that hang closer than 40 cm to the ground plane shall be folded back and forth in the center forming a bundle 30 cm to 40 cm long. All of EUT and AE shall be separate place more than 0.1 m. All 50Ω ports of the LISN shall be resistively terminated into 50Ω loads when not connected to the measuring instrument.

If the reading of the measuring receiver shows fluctuations close to the limit, the reading shall be observed for at least 15 s at each measurement frequency; the higher reading shall be recorded with the exception of any brief isolated high reading which shall be ignored

4.2. Transmitter Radiated Emissions Measurement

■ Limit

(1) Undesirable emission limits. Except as shown in paragraph (b)(9) of this section, the maximum emissions outside of the frequency bands of operation shall be attenuated in accordance with the following limits:

(a) For transmitters operating in the 5.15-5.25 GHz band: All emissions outside of the 5.15-5.35 GHz band shall not exceed an e.i.r.p. of -27 dBm/MHz.

(b) For transmitters operating in the 5.25-5.35 GHz band: All emissions outside of the 5.15-5.35 GHz band shall not exceed an e.i.r.p. of -27 dBm/MHz.

(c) For transmitters operating in the 5.47-5.725 GHz band: All emissions outside of the 5.47-5.725 GHz band shall not exceed an e.i.r.p. of -27 dBm/MHz.

(d) For transmitters operating in the 5.725-5.85 GHz band:

(i) All emissions shall be limited to a level of -27 dBm/MHz at 75 MHz or more above or below the band edge increasing linearly to 10 dBm/MHz at 25 MHz above or below the band edge, and from 25 MHz above or below the band edge increasing linearly to a level of 15.6 dBm/MHz at 5 MHz above or below the band edge, and from 5 MHz above or below the band edge increasing linearly to a level of 27 dBm/MHz at the band edge.

EIRP (dBm)	Field Strength at 3 m (dBuV/m)
-27	68.3

(2) Limits of Radiated Emission Measurement

Emissions radiated outside of the specified bands, shall be according to the general radiated limits in 15.209 as following:

Frequency Range (MHz)	Field Strength (microvolts/meter)	Measurement Distance (meters)
0.009 ~ 0.490	2400/F(kHz)	300
0.490 ~ 1.705	24000/F(kHz)	30
1.705 ~ 30.0	30	30
30 ~ 88	10	3
88 ~ 216	150	3
216 ~ 960	200	3
Above 960	500	3

- Note:
1. The lower limit shall apply at the transition frequencies.
 2. Emission level (dBuV/m) = 20 log Emission level (uV/m).
 3. As shown in 15.35(b), for frequencies above 1000 MHz, the field strength limits are based on average detector, however, the peak field strength of any emission shall not exceed the maximum permitted average limits, specified above by more than 20 dB under any condition of modulation.

■ Setup

9 kHz ~ 30 MHz

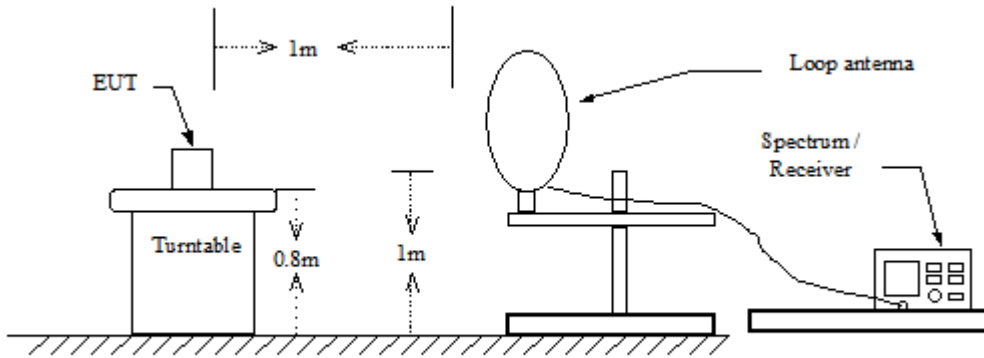

30 MHz ~ 1 GHz

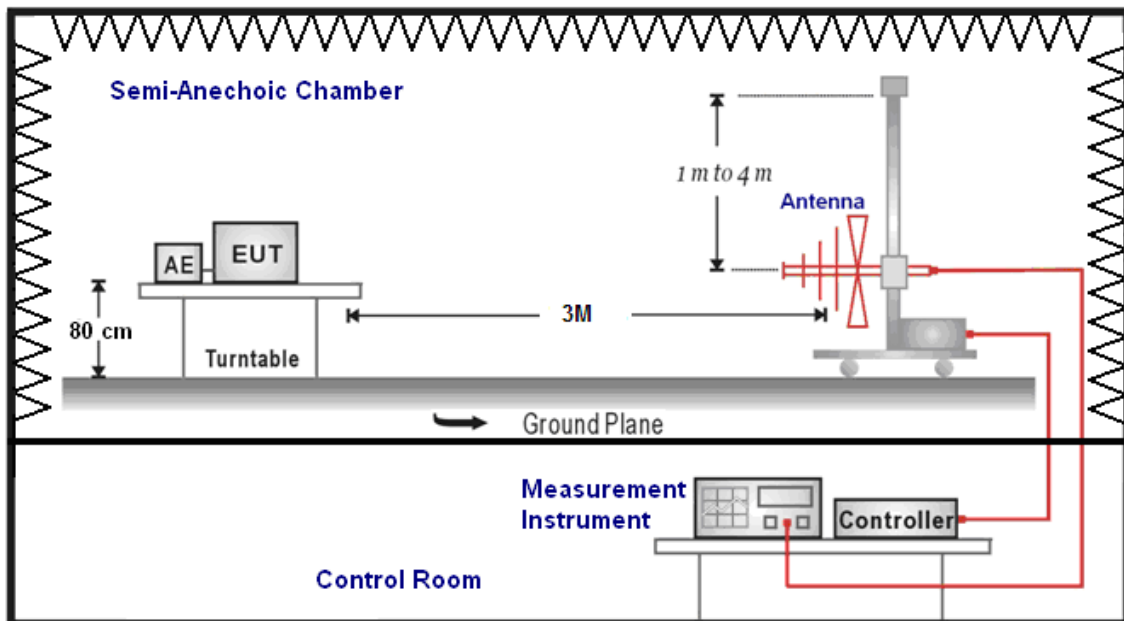

Above 1 GHz

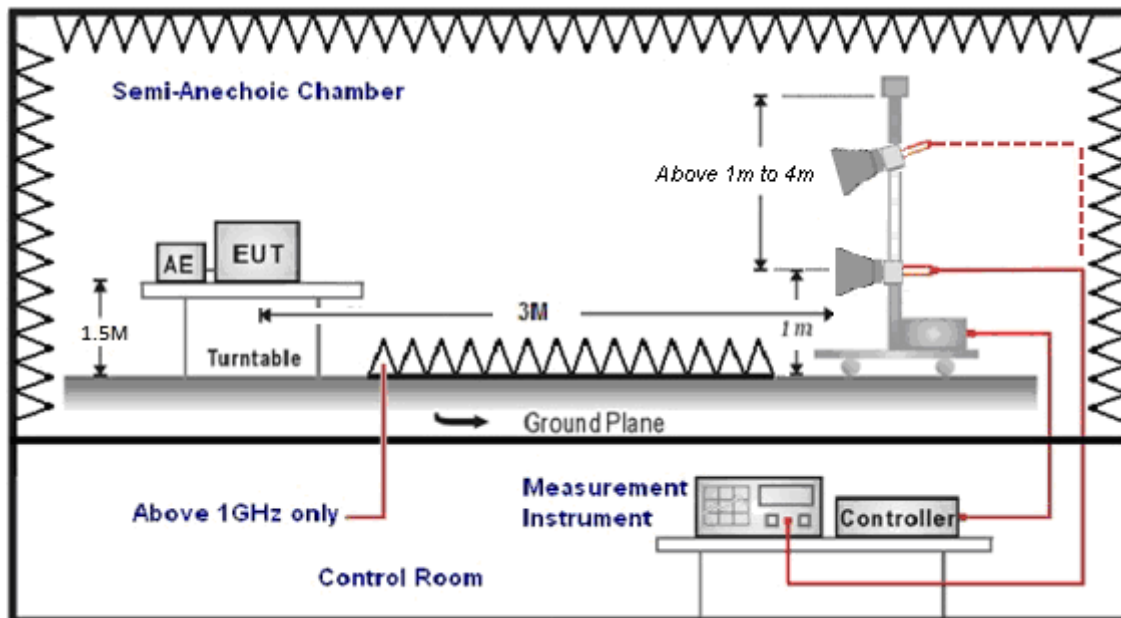

■ Test Procedure

Final radiation measurements were made on a three-meter, Semi Anechoic Chamber. The EUT system was placed on a nonconductive turntable which is 0.8 or 1.5 meters height (below 1 GHz use 0.8 m turntable / above 1 GHz use 1.5 m turntable), top surface 1.0 x 1.5 meter. The spectrum was examined from 250 MHz to 2.5 GHz in order to cover the whole spectrum below 10th harmonic which could generate from the EUT. During the test, EUT was set to transmit continuously & Measurements spectrum range from 9 kHz to 40 GHz is investigated.

For measurements below 1 GHz the resolution bandwidth is set to 100 kHz for peak detection measurements or 120 kHz for quasi-peak detection measurements. Peak detection is used unless otherwise noted as quasi-peak.

For restricted measurements above 1 GHz the resolution bandwidth is set to 1 MHz, and then the video bandwidth is set to 3 MHz for peak measurements and 10 Hz for average measurements when Duty cycle > 0.98 / 1/T for average measurements when Duty cycle < 0.98.

For out of band measurements above 1 GHz the resolution bandwidth is set to 1 MHz, and then the video bandwidth is set to 3 MHz for peak measurements.

A nonconductive material surrounded the EUT to supporting the EUT for standing on three orthogonal planes. At each condition, the EUT was rotated 360 degrees, and the antenna was raised and lowered from one to four meters to find the maximum emission levels. Measurements were taken using both horizontal and vertical antenna polarization.

SCHWARZBECK MESS-ELEKTRONIK Trilog-Broadband Antenna at 3 Meter and the ETS-Lindgren Double-Ridged Waveguide Horn antenna Schwarzbeck Mess-Elektronik Broadband Horn Antenna was used in frequencies 1 – 40 GHz at a distance of 3 meter. The antenna at an angle toward the source of the emission. All test results were extrapolated to equivalent signal at 3 meters utilizing an inverse linear distance extrapolation Factor (20 dB/decade).

For testing above 1 GHz, the emission level of the EUT in peak mode was 20 dB lower than average limit (that means the emission level in peak mode also complies with the limit in average mode), then testing will be stopped and peak values of EUT will be reported, otherwise, the emissions will be measured in average mode again and reported.

Appropriate preamplifiers were used for improving sensitivity and precautions were taken to avoid overloading or desensitizing the spectrum analyzer. No post – detector video filters were used in the test.

The spectrum analyzer's 6 dB bandwidth was set to 1 MHz, and the analyzer was operated in the peak detection mode, for frequencies both below and up 1 GHz. The average levels were obtained by subtracting the duty cycle correction factor from the peak readings.

The following procedures were used to convert the emission levels measured in decibels referenced to 1 microvolt (dBuV) into field intensity in micro volts per meter (uV/m).

The actual field intensity in decibels referenced to 1 microvolt in to field intensity in micro volts per meter (dBuV/m).

Data of measurement within this frequency range without mark in the table above means the reading of emissions are attenuated more than 20 dB below the permissible limits or the field strength is too small to be measured.

The actual field intensity in referenced to 1 microvolt per meter (dBuV/m) is determined by algebraically adding the measured reading in dBuV, the antenna factor (dB), and cable loss (dB) and Subtracting the gain of preamplifier (dB) is auto calculate in spectrum analyzer.

(1) $\text{Amplitude (dBuV/m)} = \text{FI (dBuV)} + \text{AF (dBuV)} + \text{CL (dBuV)} - \text{Gain (dB)}$

FI= Reading of the field intensity.

AF= Antenna factor.

CL= Cable loss.

P.S Amplitude is auto calculate in spectrum analyzer.

(2) $\text{Actual Amplitude (dBuV/m)} = \text{Amplitude (dBuV)} - \text{Dis(dB)}$

The FCC specified emission limits were calculated according the EUT operating frequency and by following linear interpolation equations:

(a) For fundamental frequency : Transmitter Output < +30 dBm

(b) For spurious frequency : Spurious emission limits = fundamental emission limit /10

Measuring Instruments and setting

The following table is the setting of spectrum analyzer and receiver.

Spectrum Parameter	Setting
Attenuation	Auto
Start Frequency	1000 MHz
Stop Frequency	40 GHz
RBW/VBW(Emission in restricted band)	1 MHz / 3 MHz for Peak 1 MHz / (1/T) for Average
RBW/VBW(Emission in non-restricted band)	1 MHz / 3 MHz for Peak

4.3. Maximum Conducted Output Power and Transmit power control Measurement

■ **Limit**

Frequency Range (MHz)	FCC Maximum Conducted Output Power Limit
	Master
5.150 ~ 5.250 GHz	The lesser of 1 W (30 dBm)
5.250 ~ 5.350 GHz	The lesser of 250 mW (24 dBm) or 11 dBm + 10 log (B)
5.470 ~ 5.725 GHz	The lesser of 250 mW (24 dBm) or 11 dBm + 10 log (B)
5.725 ~ 5.850 GHz	The lesser of 1 W (30 dBm)

According FCC KDB 662911 D01 v02r01 – for power measurements on IEEE802.11 devices,

CDD Mode

* Max Gain = 2 dBi < 6 dBi

IEEE 802.11a 5.47 ~ 5.725 GHz

* Power Limit = 11 + 10 * Log 16.38 = 23.14 dBm

■ **Test Setup**

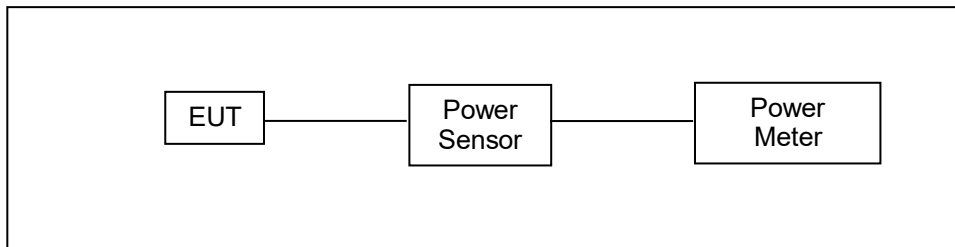

■ **Test Procedure**

The test is performed in accordance with ANSI C63.10:2013 section 12.3.3.2, Guidelines for Compliance Testing of Unlicensed National Information Infrastructure (U-NII) Devices

Section (E) Maximum Conducted Output Power

3. Measurement using a Power Meter (PM)

b) Method PM-G (Measurement using a gated RF average power meter)

4.4. 26 dB RF Bandwidth Measurement

■ **Limit**

N/A

■ **Test Setup**

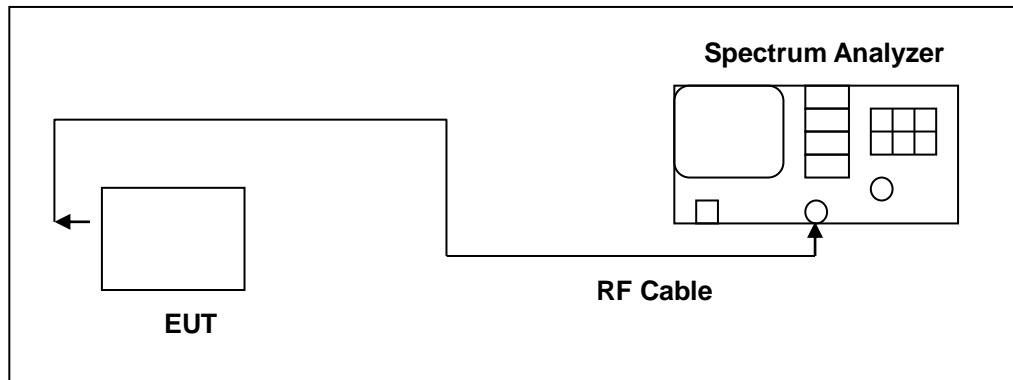

■ **Test Procedure**

The test is performed in accordance with ANSI C63.10:2013 section 12.4.1, Guidelines for Compliance Testing of Unlicensed National Information Infrastructure (U-NII) Devices - Part 15, Subpart E.

Spectrum Parameter	Setting
Attenuation	Auto
Span Frequency	>26 dB Bandwidth
RBW	Approximately 1 % of the emission bandwidth
VBW	VBW > RBW
Detector	Peak
Trace	Max Hold
Sweep Time	Auto

4.5. 6 dB RF Bandwidth Measurement

- **Limit**

- **6 dB RF Bandwidth**

Systems using digital modulation techniques may operate in the 5725~5850 MHz bands. The minimum 6 dB band-width shall be at least 500 kHz.

- **Test Setup**

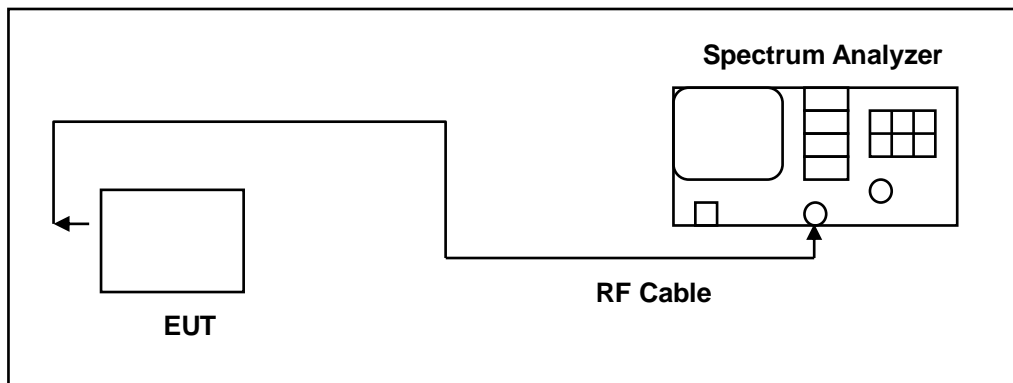

- **Test Procedure**

- **6 dB RF Bandwidth**

The EUT tested to UNII test procedure of ANSI C63.10:2013 section 6.9.2 for compliance to FCC 47CFR 15.407 requirements.

The antenna port of the EUT was connected to the input of a spectrum analyzer. Analyzer RES BW was set to 100 kHz. For each RF output channel investigated, the spectrum analyzer center frequency was set to the channel carrier. A peak output reading was taken, a DISPLAY line was drawn 6 dB lower than peak level. The 6 dB bandwidth was determined from where the channel output spectrum intersected the display line.

The test was performed at 3 channels.

4.6. Maximum Power Spectral Density Measurement

■ **Limit**

Frequency Range (MHz)	FCC Limit
	Master
5.150 ~ 5.250 GHz	17 dBm/MHz
5.250 ~ 5.350 GHz	11 dBm/MHz
5.470 ~ 5.725 GHz	11 dBm/MHz
5.725 ~ 5.850 GHz	30 dBm/500 kHz

According FCC KDB 662911 D01 v02r01 – for power spectral density measurements on IEEE802.11 devices,

■ **Test Setup**

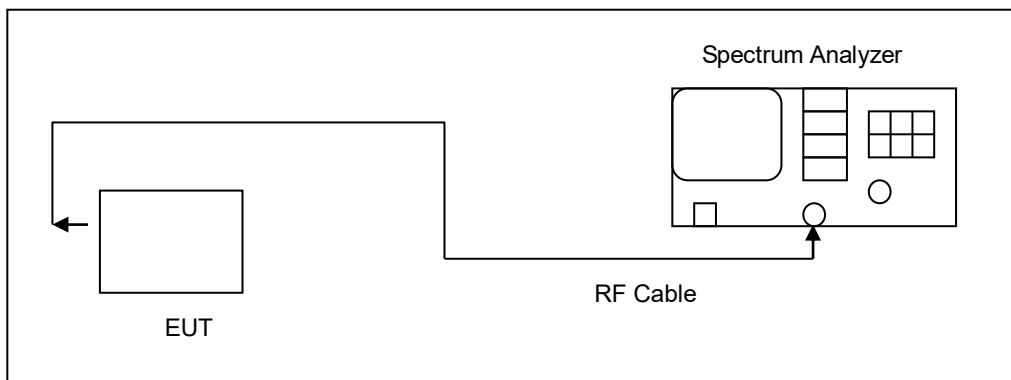

■ **Test Procedure**

The test is performed in accordance with ANSI C63.10:2013 section 12.5, Guidelines for Compliance Testing of Unlicensed National Information Infrastructure (U-NII) Devices - Part 15, Subpart E.

Spectrum Parameter	Setting
Attenuation	Auto
Span Frequency	Encompass the entire emissions bandwidth (EBW) of the signal
RBW	1 MHz (5725 ~ 5850 MHz use 100 kHz)
VBW	3 MHz (5725 ~ 5850 MHz use 300 kHz)
Detector	RMS
Trace	AVERAGE
Sweep Time	Auto
Trace Average	100 times
Note: If measurement bandwidth of Maximum PSD is specified in 500 kHz, add $10 \log(500 \text{ kHz}/100 \text{ kHz})$ to the measured result.	

4.7. Automatically discontinue transmission

The device shall automatically discontinue transmission in case of either absence of information to transmit or operational failure. These provisions are not intended to preclude the transmission of control or signalling information or the use of repetitive codes used by certain digital technologies to complete frame or burst intervals. Applicants shall include in their application for equipment authorization a description of how this requirement is met.

- **Declare**

While the EUT is not transmitting any information, the EUT can automatically discontinue transmission and become standby mode for power saving.

The EUT can detect the controlling signal of ACK message transmitting from remote device and verify whether it shall resend or discontinue transmission.

4.8. Antenna Requirement

- **Requirement**

For intentional device, according to 15.203, an intentional radiator shall be designed to ensure that no antenna other than that furnished by the responsible party shall be used with the device.

And According to 15.407 (a), if transmitting antennas of directional gain greater than 6 dBi are used, the power shall be reduced by the amount in dB that the directional gain of the antenna exceeds 6 dBi.

- **Antenna Connector Construction**

See section 2 – antenna information.

■ **Directional Gain Calculated**

For Maximum Conducted Output Power

$$\text{Directional Gain} = 10 \cdot \log\left\{\frac{10^{G1/10} + 10^{G2/10} + \dots + 10^{Gn/10}}{NANT}\right\}$$

Operate Freq. Band		Directional Gain (dBi)
IEEE 802.11a	U-NII Band 1	2
	U-NII Band 2-A	2
	U-NII Band 2-C	2
	U-NII Band 3	2
IEEE 802.11n 5 GHz 20 MHz / IEEE 802.11ac 20 MHz/ IEEE 802.11ax 20 MHz	U-NII Band 1	2
	U-NII Band 2-A	2
	U-NII Band 2-C	2
	U-NII Band 3	2
IEEE 802.11n 5 GHz 40 MHz / IEEE 802.11ac 40 MHz/ IEEE 802.11ax 40 MHz	U-NII Band 1	2
	U-NII Band 2-A	2
	U-NII Band 2-C	2
	U-NII Band 3	2
IEEE 802.11ac 80 MHz/ IEEE 802.11ax 80 MHz	U-NII Band 1	2
	U-NII Band 2-A	2
	U-NII Band 2-C	2
	U-NII Band 3	2

For Maximum Power Density

$$\text{Directional Gain} = GANT + \text{Array Gain}$$

Array Gain is the actual measurement.

Operate Freq. Band		Directional Gain (dBi)
IEEE 802.11a	U-NII Band 1	4.81
	U-NII Band 2-A	4.81
	U-NII Band 2-C	4.81
	U-NII Band 3	4.81
IEEE 802.11n 5 GHz 20 MHz / IEEE 802.11ac 20 MHz/ IEEE 802.11ax 20 MHz	U-NII Band 1	4.81
	U-NII Band 2-A	4.81
	U-NII Band 2-C	4.81
	U-NII Band 3	4.81
IEEE 802.11n 5 GHz 40 MHz / IEEE 802.11ac 40 MHz/ IEEE 802.11ax 40 MHz	U-NII Band 1	4.81
	U-NII Band 2-A	4.81
	U-NII Band 2-C	4.81
	U-NII Band 3	4.81
IEEE 802.11ac 80 MHz/ IEEE 802.11ax 80 MHz	U-NII Band 1	4.81
	U-NII Band 2-A	4.81
	U-NII Band 2-C	4.81
	U-NII Band 3	4.81

Beamforming on

For Maximum Conducted Output Power

Directional Gain = GANT + Array Gain

Array Gain is the actual measurement.

Operate Freq. Band		Directional Gain (dBi)
IEEE 802.11n 5 GHz 20 MHz / IEEE 802.11ac 20 MHz/ IEEE 802.11ax 20 MHz	U-NII Band 1	4.81
	U-NII Band 2-A	4.81
	U-NII Band 2-C	4.81
	U-NII Band 3	4.81
IEEE 802.11n 5 GHz 40 MHz / IEEE 802.11ac 40 MHz/ IEEE 802.11ax 40 MHz	U-NII Band 1	4.81
	U-NII Band 2-A	4.81
	U-NII Band 2-C	4.81
	U-NII Band 3	4.81
IEEE 802.11ac 80 MHz/ IEEE 802.11ax 80 MHz	U-NII Band 1	4.81
	U-NII Band 2-A	4.81
	U-NII Band 2-C	4.81
	U-NII Band 3	4.81

For Maximum Power Density

Directional Gain = GANT + Array Gain

Array Gain is the actual measurement.

Operate Freq. Band		Directional Gain (dBi)
IEEE 802.11n 5 GHz 20 MHz / IEEE 802.11ac 20 MHz/ IEEE 802.11ax 20 MHz	U-NII Band 1	4.81
	U-NII Band 2-A	4.81
	U-NII Band 2-C	4.81
	U-NII Band 3	4.81
IEEE 802.11n 5 GHz 40 MHz / IEEE 802.11ac 40 MHz/ IEEE 802.11ax 40 MHz	U-NII Band 1	4.81
	U-NII Band 2-A	4.81
	U-NII Band 2-C	4.81
	U-NII Band 3	4.81
IEEE 802.11ac 80 MHz/ IEEE 802.11ax 80 MHz	U-NII Band 1	4.81
	U-NII Band 2-A	4.81
	U-NII Band 2-C	4.81
	U-NII Band 3	4.81

5 Test Results

5.1. Conducted Emission

Standard:	FCC Part 15.407	Line:	L1
Test item:	Conducted Emission	Power:	AC 120 V/60 Hz
Mode:	Mode 1		
Description:			

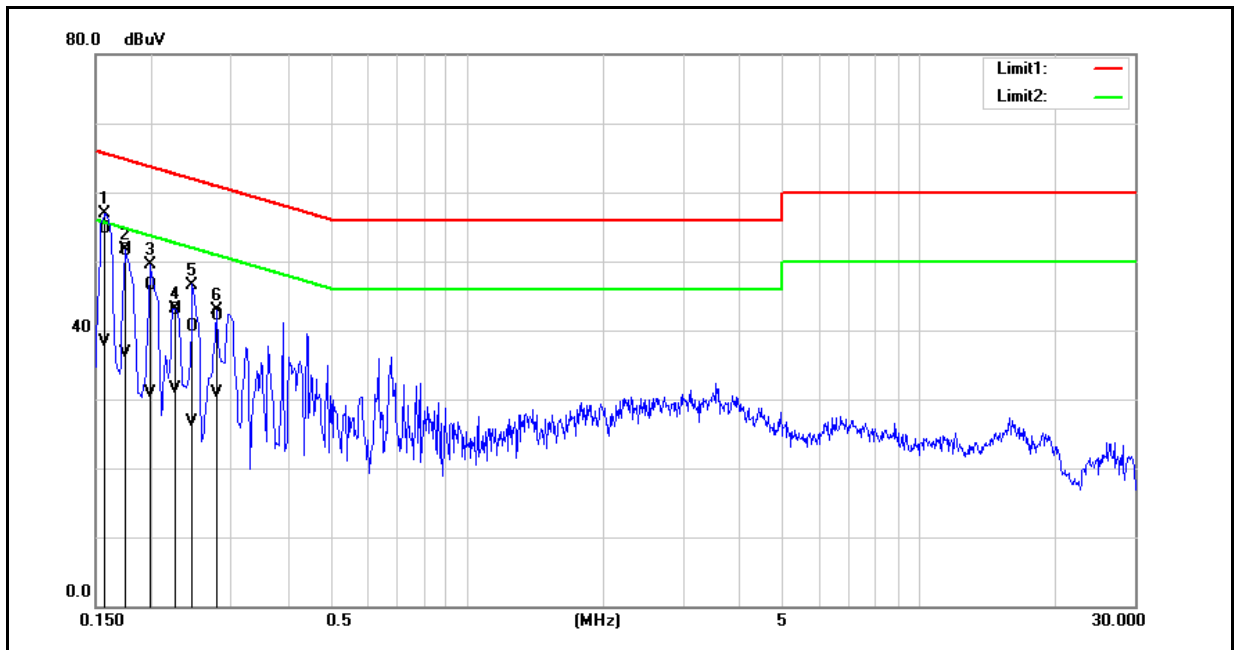

No.	Frequency (MHz)	QP reading (dBuV)	AVG reading (dBuV)	Correction factor (dB)	QP result (dBuV)	AVG result (dBuV)	QP limit (dBuV)	AVG limit (dBuV)	QP margin (dB)	AVG margin (dB)	Remark
1	0.1580	45.17	28.76	9.60	54.77	38.36	65.57	55.57	-10.80	-17.21	Pass
2	0.1740	41.94	27.07	9.60	51.54	36.67	64.77	54.77	-13.23	-18.10	Pass
3	0.1980	36.99	21.36	9.60	46.59	30.96	63.69	53.69	-17.10	-22.73	Pass
4	0.2260	33.38	21.81	9.60	42.98	31.41	62.60	52.60	-19.62	-21.19	Pass
5	0.2460	30.96	17.19	9.60	40.56	26.79	61.89	51.89	-21.33	-25.10	Pass
6	0.2780	32.42	21.35	9.60	42.02	30.95	60.88	50.88	-18.86	-19.93	Pass

Note: 1. Result (dBuV) = Correction factor (dB) + Reading(dBuV).

2. Correction factor (dB) = Cable loss (dB) + L.I.S.N. factor (dB).

Standard:	FCC Part 15.407	Line:	N
Test item:	Conducted Emission	Power:	AC 120 V/60 Hz
Mode:	Mode 1		
Description:			

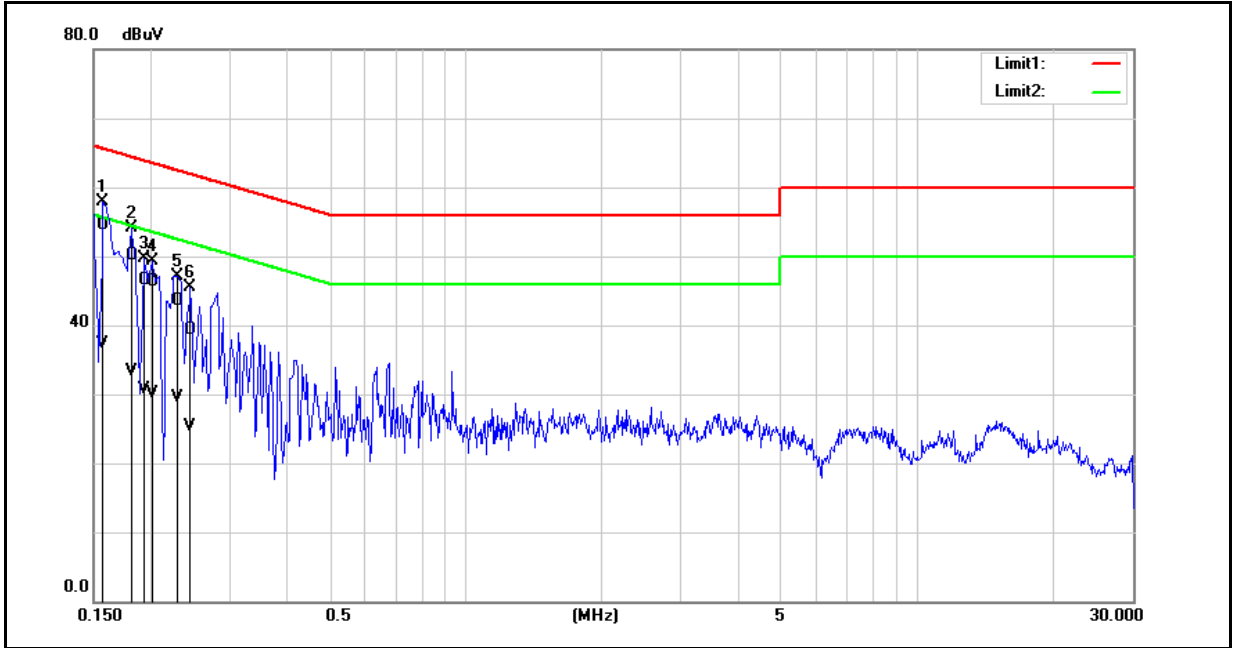

No.	Frequency (MHz)	QP reading (dBuV)	AVG reading (dBuV)	Correction factor (dB)	QP result (dBuV)	AVG result (dBuV)	QP limit (dBuV)	AVG limit (dBuV)	QP margin (dB)	AVG margin (dB)	Remark
1	0.1580	44.80	27.70	9.66	54.46	37.36	65.57	55.57	-11.11	-18.21	Pass
2	0.1820	40.38	23.67	9.66	50.04	33.33	64.39	54.39	-14.35	-21.06	Pass
3	0.1940	36.81	21.03	9.66	46.47	30.69	63.86	53.86	-17.39	-23.17	Pass
4	0.2020	36.69	20.44	9.66	46.35	30.10	63.53	53.53	-17.18	-23.43	Pass
5	0.2300	33.93	19.83	9.66	43.59	29.49	62.45	52.45	-18.86	-22.96	Pass
6	0.2460	29.70	15.74	9.66	39.36	25.40	61.89	51.89	-22.53	-26.49	Pass

Note: 1. Result (dBuV) = Correction factor (dB) + Reading(dBuV).
2. Correction factor (dB) = Cable loss (dB) + L.I.S.N. factor (dB).

5.2. Radiated Emission Measurement

Below 1 GHz

Standard:	FCC Part 15.407	Test Distance:	3 m
Test item:	Radiated Emission		
Frequency:	5500 MHz		
Mode:	Mode 2		
Ant.Polar.:	Horizontal		

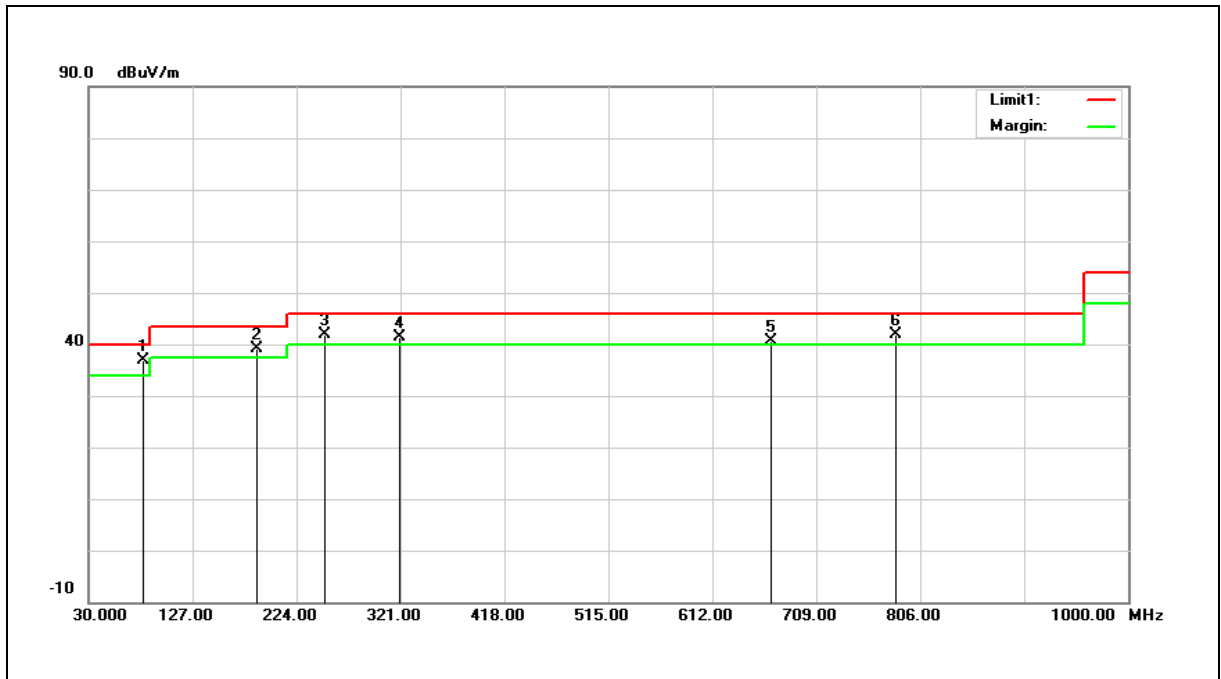

No.	Frequency (MHz)	Reading (dBuV)	Correct Factor (dB/m)	Result (dBuV/m)	Limit (dBuV/m)	Margin (dB)	Remark
1	81.4100	52.47	-15.54	36.93	40.00	-3.07	QP
2	187.1400	51.76	-12.65	39.11	43.50	-4.39	QP
3	250.1900	53.14	-11.36	41.78	46.00	-4.22	QP
4	320.0300	50.42	-9.11	41.31	46.00	-4.69	QP
5	666.3200	41.85	-1.29	40.56	46.00	-5.44	QP
6	783.6900	41.34	0.66	42.00	46.00	-4.00	QP

Note:1.Result (dBuV/m) = Correct Factor (dB/m) + Reading(dBuV).

2.Correction factor (dB/m) = Antenna Factor (dB/m) + Cable loss (dB) – Pre-Amplifier gain (dB).

3.When the peak results are less than average limit, so not need to evaluate the average.

Standard:	FCC Part 15.407	Test Distance:	3 m
Test item:	Radiated Emission		
Frequency:	5500 MHz		
Mode:	Mode 2		
Ant.Polar.:	Vertical		

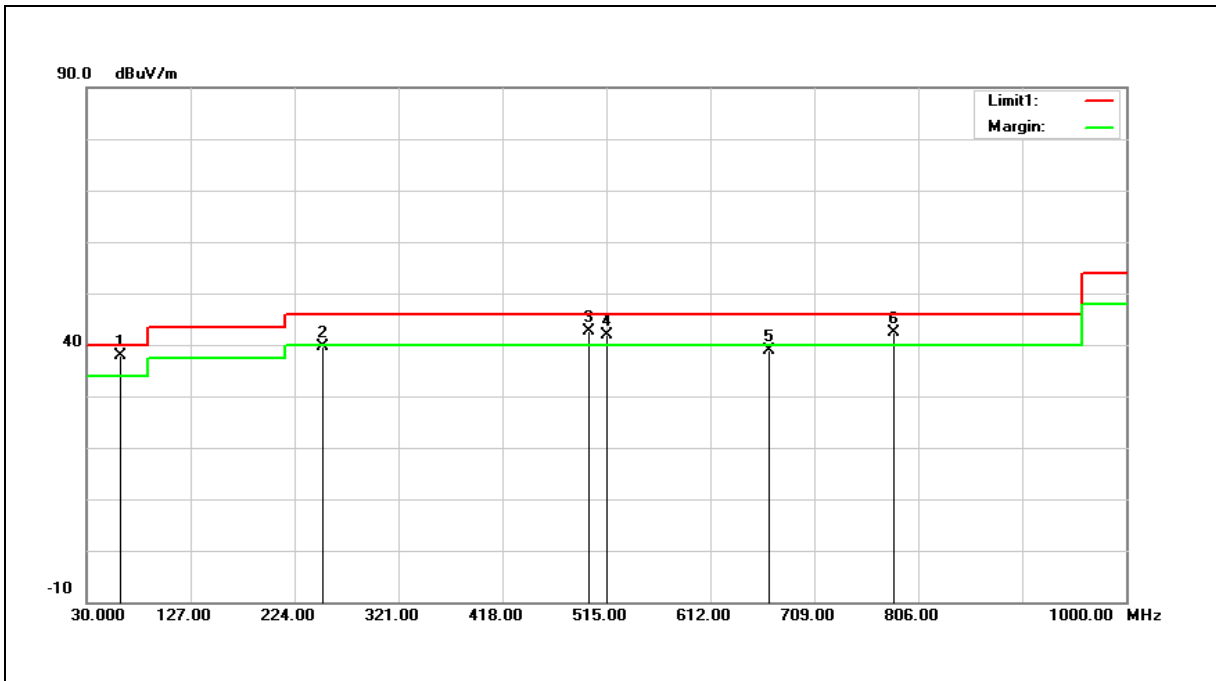

No.	Frequency (MHz)	Reading (dBuV)	Correct Factor (dB/m)	Result (dBuV/m)	Limit (dBuV/m)	Margin (dB)	Remark
1	62.0100	49.35	-11.52	37.83	40.00	-2.17	QP
2	250.1900	51.06	-11.36	39.70	46.00	-6.30	QP
3	498.5100	47.23	-4.54	42.69	46.00	-3.31	QP
4	515.0000	46.18	-4.29	41.89	46.00	-4.11	QP
5	666.3200	40.06	-1.29	38.77	46.00	-7.23	QP
6	783.6900	41.83	0.66	42.49	46.00	-3.51	QP

Note:1.Result (dBuV/m) = Correct Factor (dB/m) + Reading(dBuV).

2.Correction factor (dB/m) = Antenna Factor (dB/m) + Cable loss (dB) – Pre-Amplifier gain (dB).

3.When the peak results are less than average limit, so not need to evaluate the average.

Above 1 GHz

Standard:	FCC Part 15.407	Test Distance:	3 m
Test item:	Harmonic		
Frequency:	5260 MHz		
Mode:	Mode 2		
Ant.Polar.:	Horizontal		

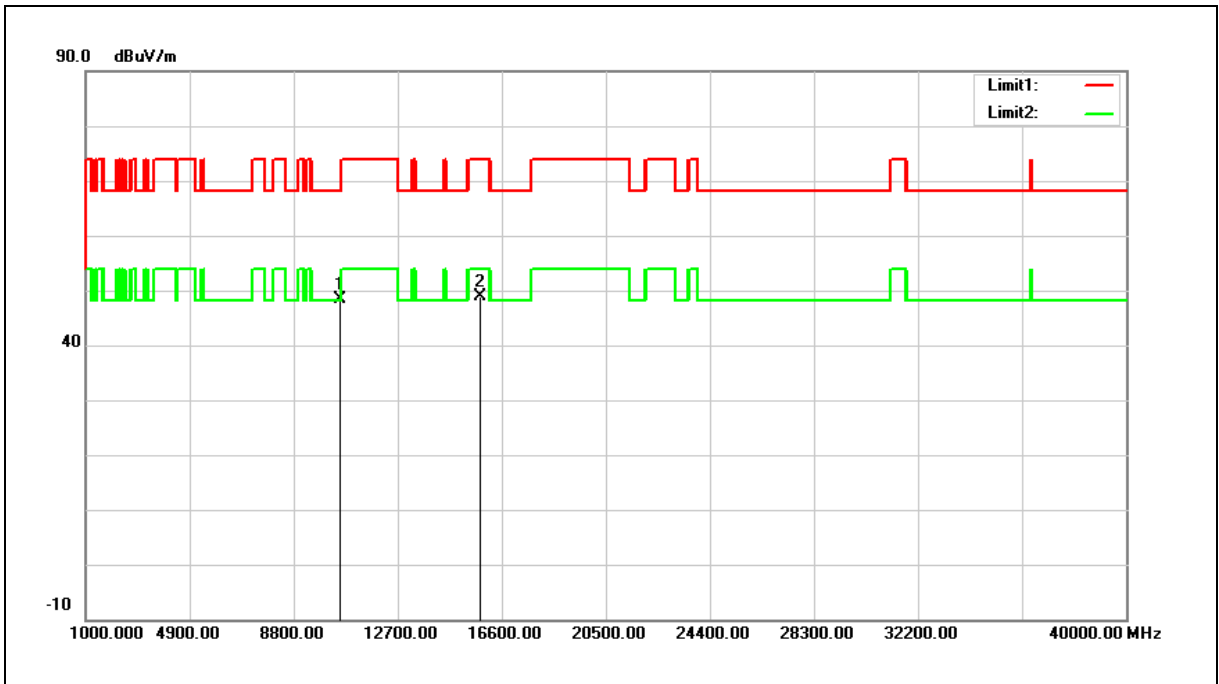

No.	Frequency (MHz)	Reading (dBuV)	Correct Factor (dB/m)	Result (dBuV/m)	Limit (dBuV/m)	Margin (dB)	Remark
1	10520.000	31.12	17.20	48.17	68.20	-20.03	peak
2	15780.000	31.15	17.82	48.78	74.00	-25.22	peak

Note:1.Result (dBuV/m) = Correct Factor (dB/m) + Reading(dBuV).

2.Correction factor (dB/m) = Antenna Factor (dB/m) + Cable loss (dB) – Pre-Amplifier gain (dB).

3.When the peak results are less than average limit, so not need to evaluate the average.

Standard:	FCC Part 15.407	Test Distance:	3 m
Test item:	Harmonic		
Frequency:	5260 MHz		
Mode:	Mode 2		
Ant.Polar.:	Vertical		

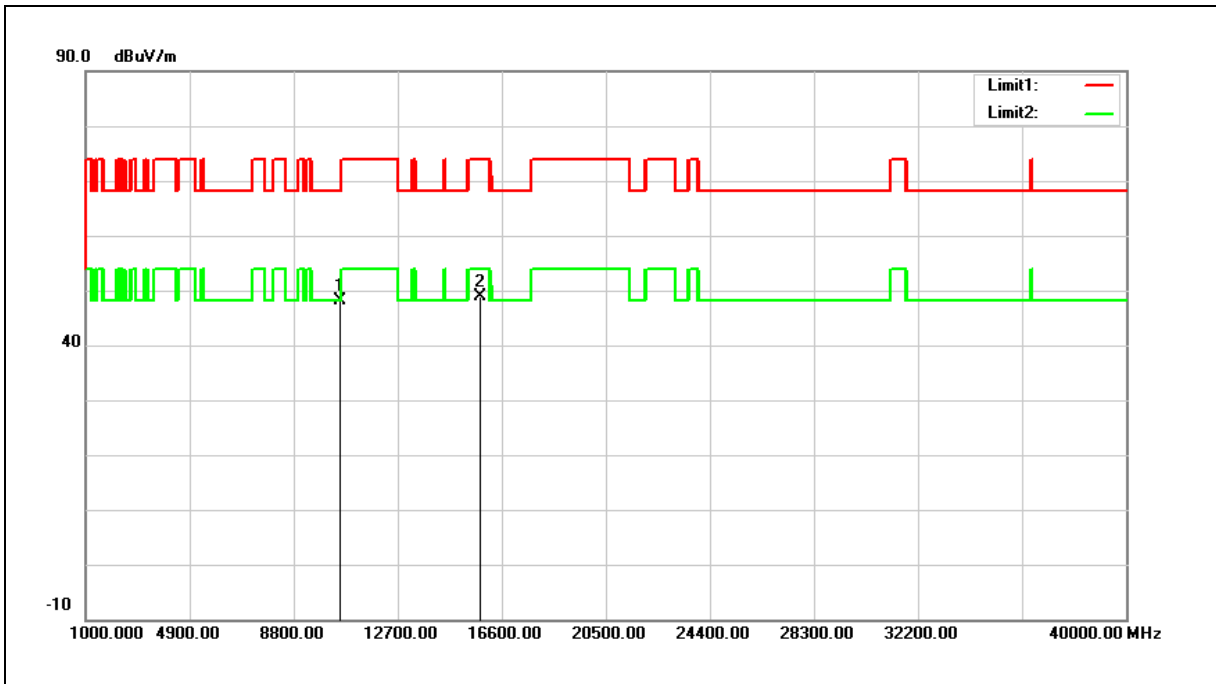

No.	Frequency (MHz)	Reading (dBuV)	Correct Factor (dB/m)	Result (dBuV/m)	Limit (dBuV/m)	Margin (dB)	Remark
1	10520.000	31.02	17.20	48.14	68.20	-20.06	peak
2	15780.000	30.95	17.82	48.75	74.00	-25.25	peak

Note:1.Result (dBuV/m) = Correct Factor (dB/m) + Reading(dBuV).

2.Correction factor (dB/m) = Antenna Factor (dB/m) + Cable loss (dB) – Pre-Amplifier gain (dB).

3.When the peak results are less than average limit, so not need to evaluate the average.

Standard:	FCC Part 15.407	Test Distance:	3 m
Test item:	Harmonic		
Frequency:	5280 MHz		
Mode:	Mode 2		
Ant.Polar.:	Horizontal		

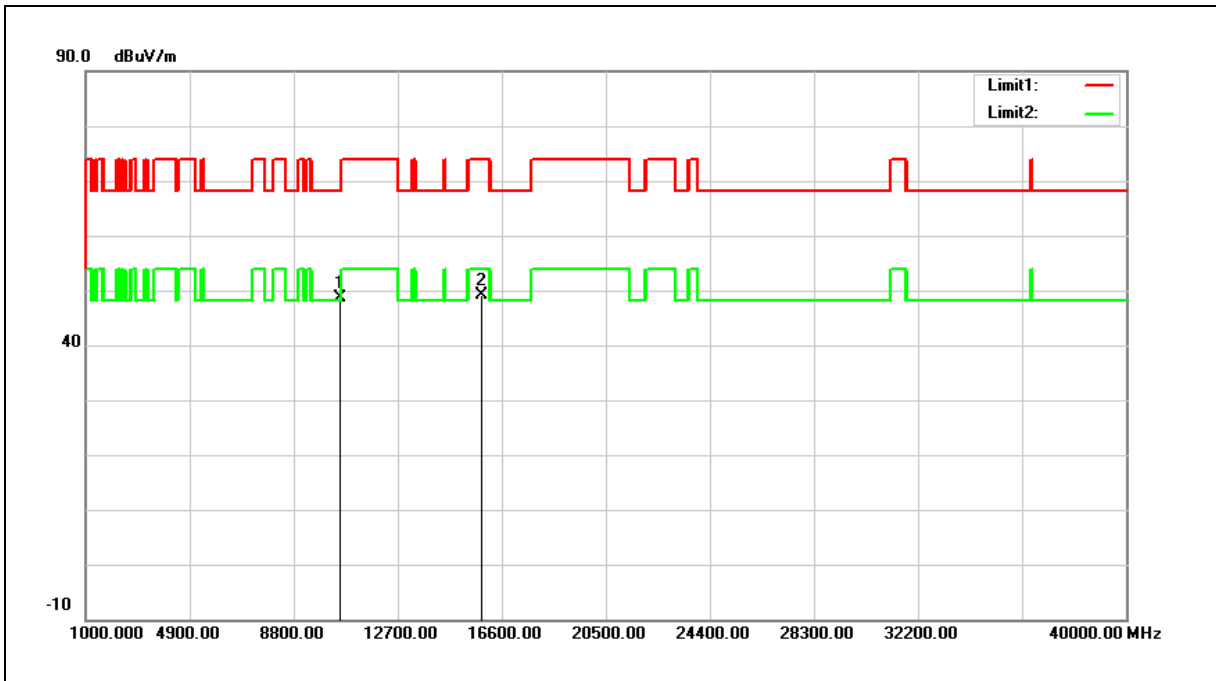

No.	Frequency (MHz)	Reading (dBuV)	Correct Factor (dB/m)	Result (dBuV/m)	Limit (dBuV/m)	Margin (dB)	Remark
1	10560.000	31.22	17.29	48.46	68.20	-19.74	peak
2	15840.000	31.47	17.65	49.01	74.00	-24.99	peak

Note:1.Result (dBuV/m) = Correct Factor (dB/m) + Reading(dBuV).

2.Correction factor (dB/m) = Antenna Factor (dB/m) + Cable loss (dB) – Pre-Amplifier gain (dB).

3.When the peak results are less than average limit, so not need to evaluate the average.

Standard:	FCC Part 15.407	Test Distance:	3 m
Test item:	Harmonic		
Frequency:	5280 MHz		
Mode:	Mode 2		
Ant.Polar.:	Vertical		

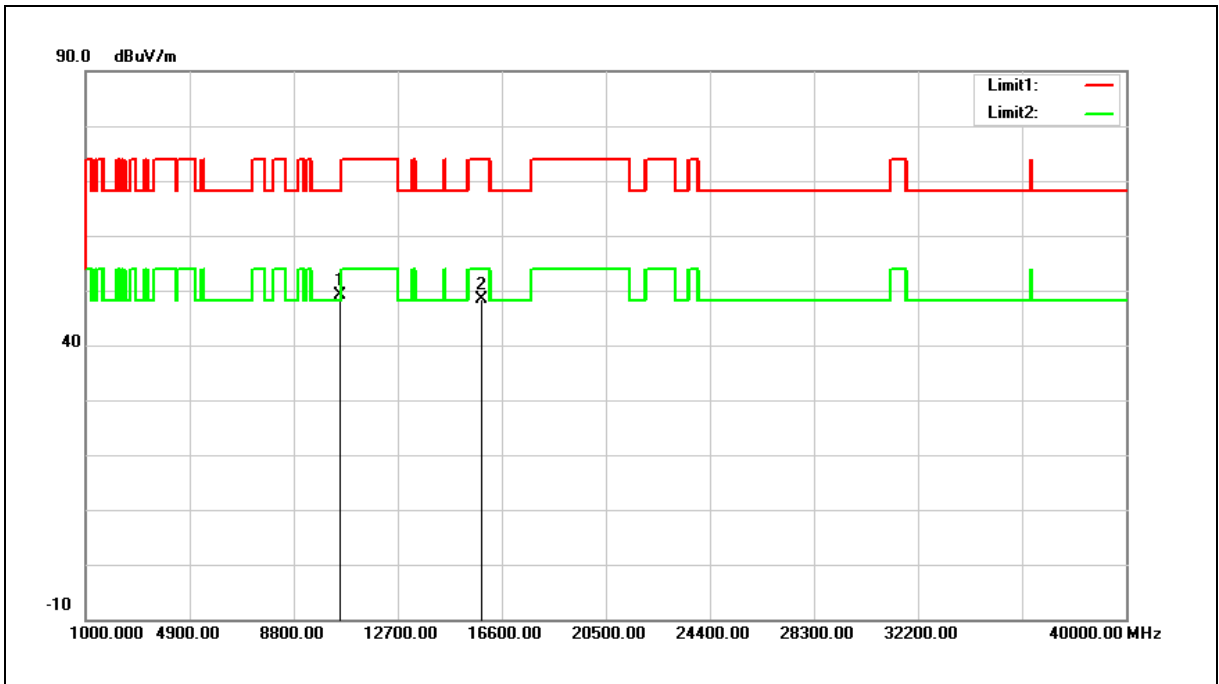

No.	Frequency (MHz)	Reading (dBuV)	Correct Factor (dB/m)	Result (dBuV/m)	Limit (dBuV/m)	Margin (dB)	Remark
1	10560.000	31.94	17.29	49.15	68.20	-19.05	peak
2	15840.000	30.81	17.65	48.37	74.00	-25.63	peak

Note:1.Result (dBuV/m) = Correct Factor (dB/m) + Reading(dBuV).

2.Correction factor (dB/m) = Antenna Factor (dB/m) + Cable loss (dB) – Pre-Amplifier gain (dB).

3.When the peak results are less than average limit, so not need to evaluate the average.

Standard:	FCC Part 15.407	Test Distance:	3 m
Test item:	Harmonic		
Frequency:	5320 MHz		
Mode:	Mode 2		
Ant.Polar.:	Horizontal		

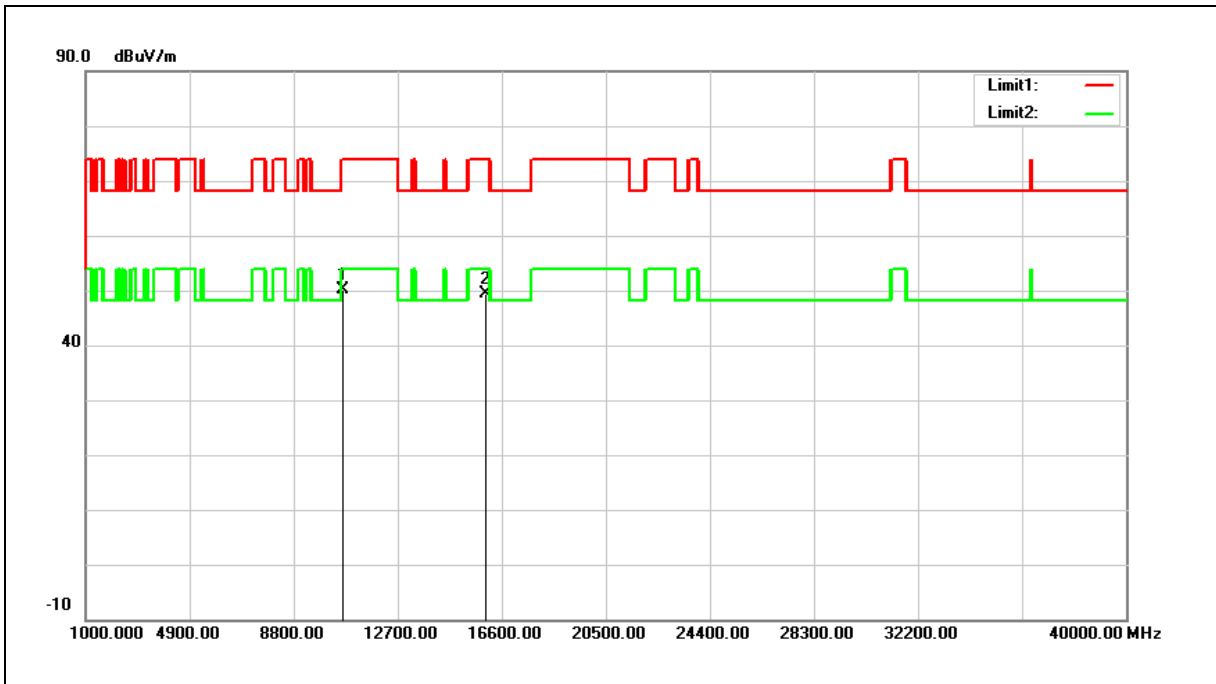

No.	Frequency (MHz)	Reading (dBuV)	Correct Factor (dB/m)	Result (dBuV/m)	Limit (dBuV/m)	Margin (dB)	Remark
1	10640.000	32.58	17.48	50.06	74.00	-23.94	peak
2	15960.000	32.03	17.31	49.34	74.00	-24.66	peak

- Note:1.Result (dBuV/m) = Correct Factor (dB/m) + Reading(dBuV).
 2.Correction factor (dB/m) = Antenna Factor (dB/m) + Cable loss (dB) – Pre-Amplifier gain (dB).
 3.When the peak results are less than average limit, so not need to evaluate the average.

Standard:	FCC Part 15.407	Test Distance:	3 m
Test item:	Harmonic		
Frequency:	5320 MHz		
Mode:	Mode 2		
Ant.Polar.:	Vertical		

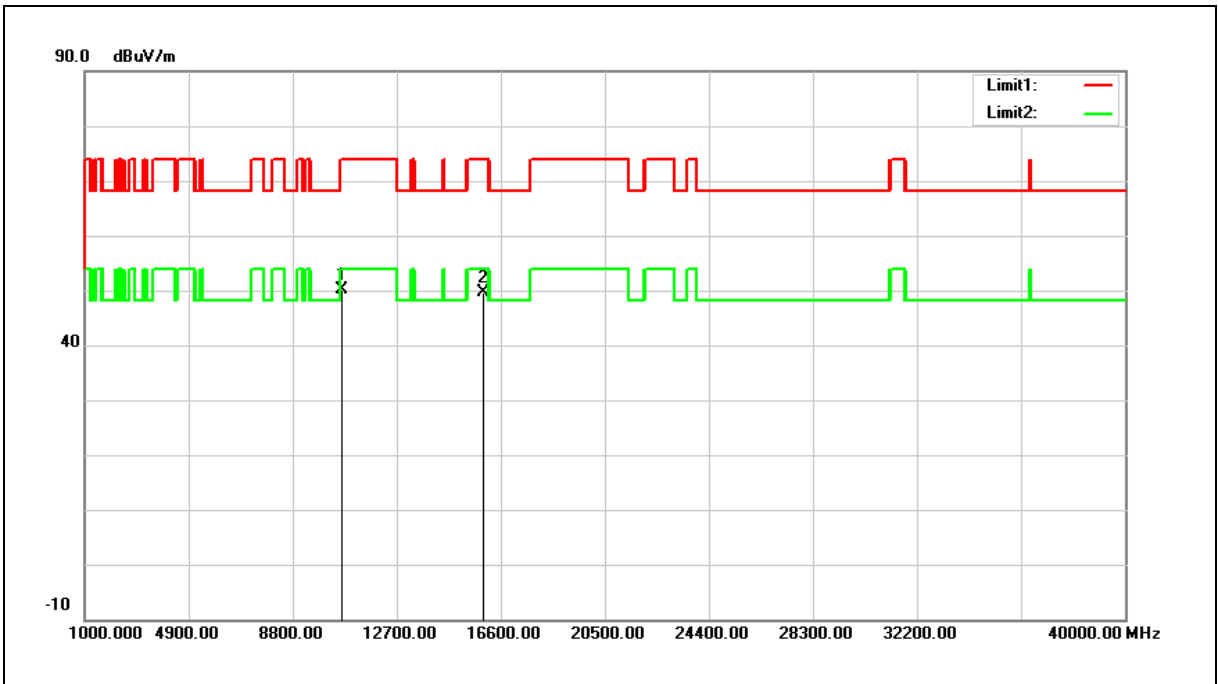

No.	Frequency (MHz)	Reading (dBuV)	Correct Factor (dB/m)	Result (dBuV/m)	Limit (dBuV/m)	Margin (dB)	Remark
1	10640.000	32.61	17.48	50.09	74.00	-23.91	peak
2	15960.000	32.32	17.31	49.63	74.00	-24.37	peak

Note:1.Result (dBuV/m) = Correct Factor (dB/m) + Reading(dBuV).

2.Correction factor (dB/m) = Antenna Factor (dB/m) + Cable loss (dB) – Pre-Amplifier gain (dB).

3.When the peak results are less than average limit, so not need to evaluate the average.

Standard:	FCC Part 15.407	Test Distance:	3 m
Test item:	Harmonic		
Frequency:	5500 MHz		
Mode:	Mode 2		
Ant.Polar.:	Horizontal		

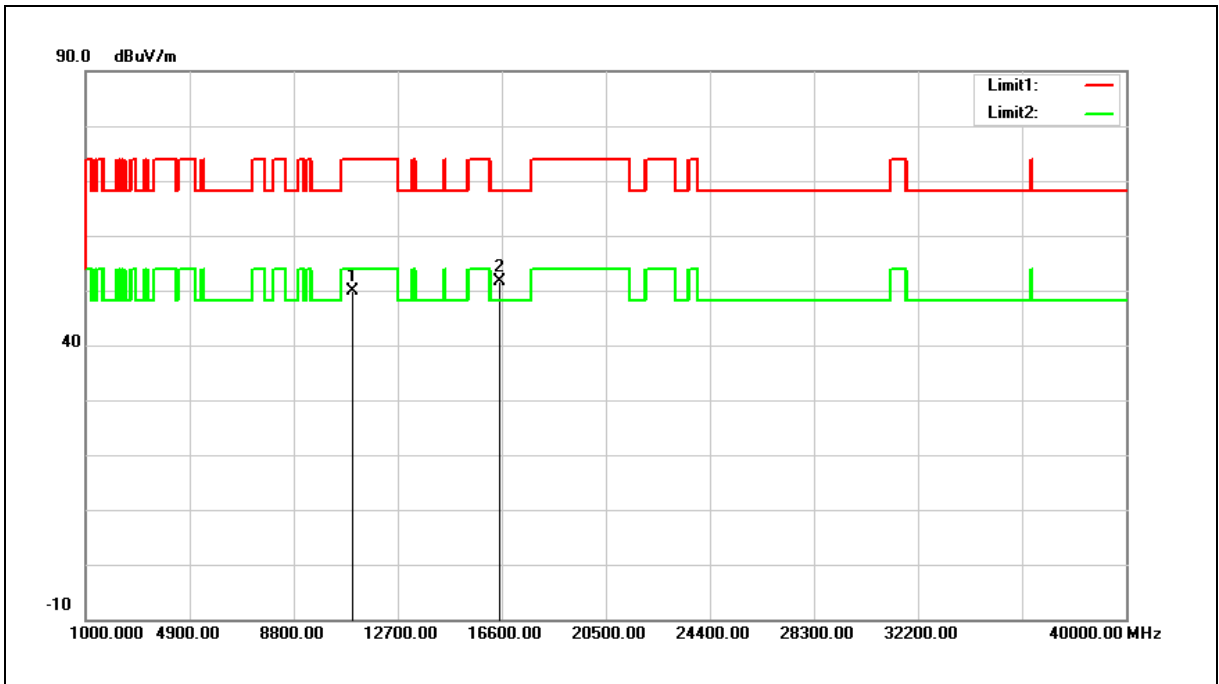

No.	Frequency (MHz)	Reading (dBuV)	Correct Factor (dB/m)	Result (dBuV/m)	Limit (dBuV/m)	Margin (dB)	Remark
1	11000.000	31.64	18.29	49.93	74.00	-24.07	peak
2	16500.000	31.73	19.79	51.52	68.20	-16.68	peak

Note:1.Result (dBuV/m) = Correct Factor (dB/m) + Reading(dBuV).

2.Correction factor (dB/m) = Antenna Factor (dB/m) + Cable loss (dB) – Pre-Amplifier gain (dB).

3.When the peak results are less than average limit, so not need to evaluate the average.

Standard:	FCC Part 15.407	Test Distance:	3 m
Test item:	Harmonic		
Frequency:	5500 MHz		
Mode:	Mode 2		
Ant.Polar.:	Vertical		

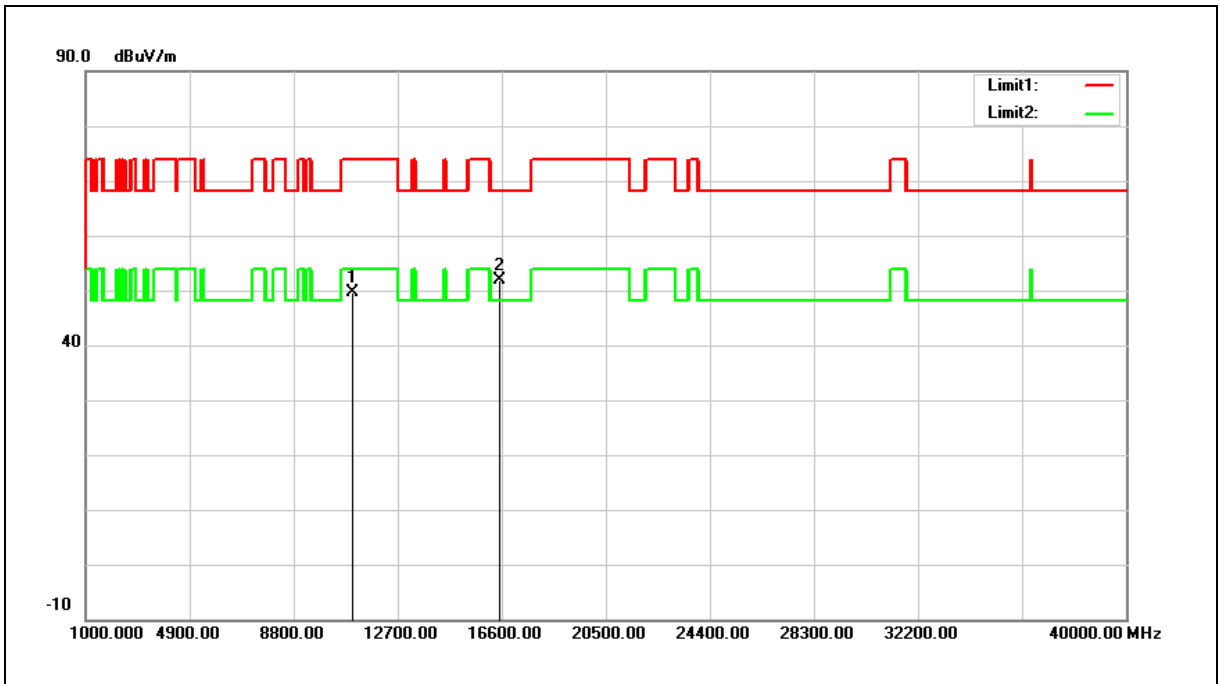

No.	Frequency (MHz)	Reading (dBuV)	Correct Factor (dB/m)	Result (dBuV/m)	Limit (dBuV/m)	Margin (dB)	Remark
1	11000.000	31.37	18.29	49.66	74.00	-24.34	peak
2	16500.000	32.06	19.79	51.85	68.20	-16.35	peak

Note:1.Result (dBuV/m) = Correct Factor (dB/m) + Reading(dBuV).

2.Correction factor (dB/m) = Antenna Factor (dB/m) + Cable loss (dB) – Pre-Amplifier gain (dB).

3.When the peak results are less than average limit, so not need to evaluate the average.

Standard:	FCC Part 15.407	Test Distance:	3 m
Test item:	Harmonic		
Frequency:	5560 MHz		
Mode:	Mode 2		
Ant.Polar.:	Horizontal		

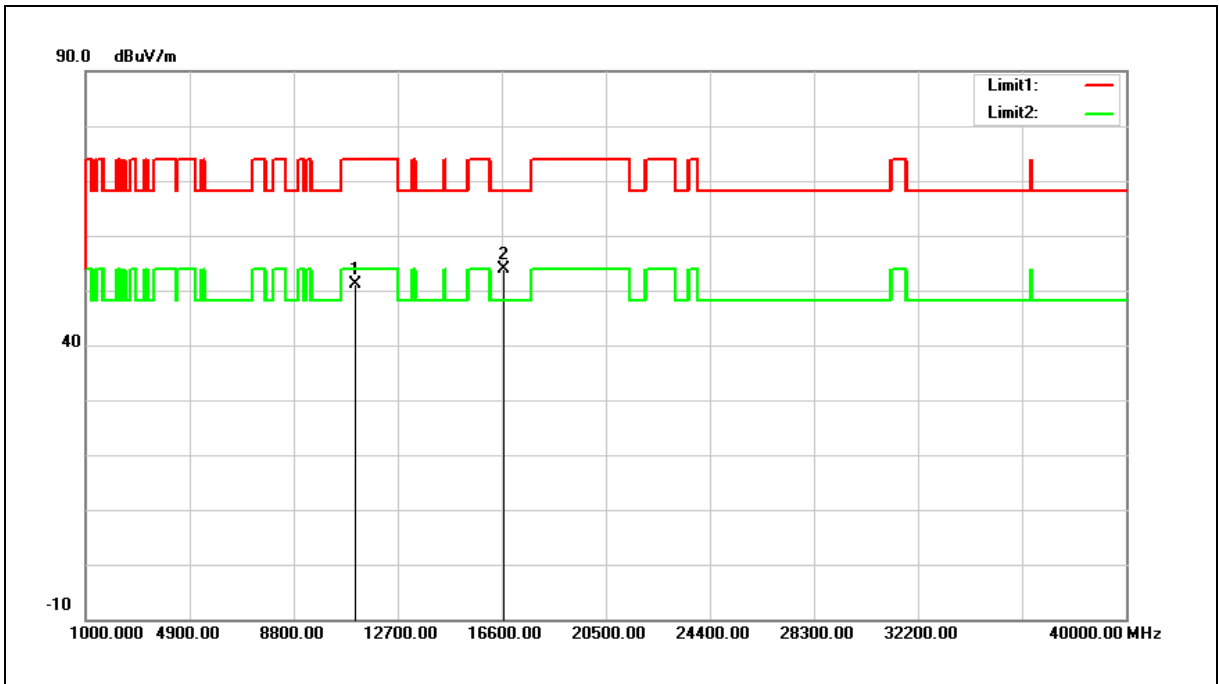

No.	Frequency (MHz)	Reading (dBuV)	Correct Factor (dB/m)	Result (dBuV/m)	Limit (dBuV/m)	Margin (dB)	Remark
1	11120.000	32.87	18.34	51.21	74.00	-22.79	peak
2	16680.000	32.82	20.94	53.76	68.20	-14.44	peak

Note:1.Result (dBuV/m) = Correct Factor (dB/m) + Reading(dBuV).

2.Correction factor (dB/m) = Antenna Factor (dB/m) + Cable loss (dB) – Pre-Amplifier gain (dB).

3.When the peak results are less than average limit, so not need to evaluate the average.

Standard:	FCC Part 15.407	Test Distance:	3 m
Test item:	Harmonic		
Frequency:	5560 MHz		
Mode:	Mode 2		
Ant.Polar.:	Vertical		

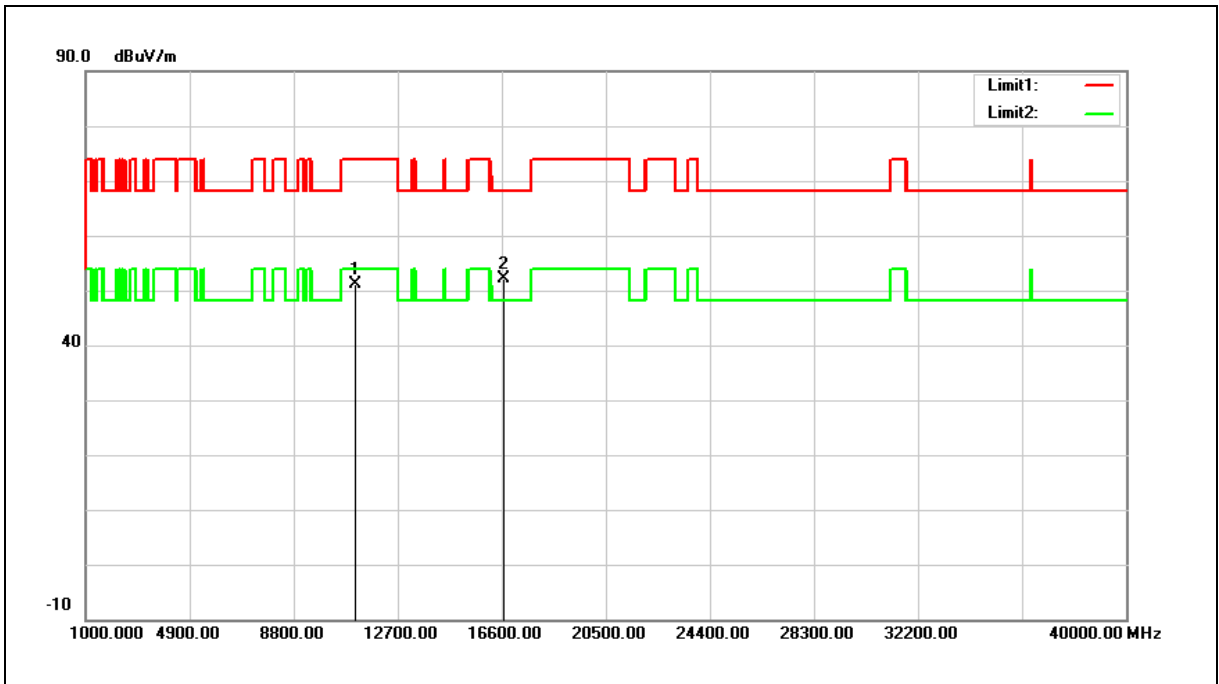

No.	Frequency (MHz)	Reading (dBuV)	Correct Factor (dB/m)	Result (dBuV/m)	Limit (dBuV/m)	Margin (dB)	Remark
1	11120.000	32.85	18.34	51.19	74.00	-22.81	peak
2	16680.000	31.22	20.94	52.16	68.20	-16.04	peak

Note:1.Result (dBuV/m) = Correct Factor (dB/m) + Reading(dBuV).

2.Correction factor (dB/m) = Antenna Factor (dB/m) + Cable loss (dB) – Pre-Amplifier gain (dB).

3.When the peak results are less than average limit, so not need to evaluate the average.

Standard:	FCC Part 15.407	Test Distance:	3 m
Test item:	Harmonic		
Frequency:	5700 MHz		
Mode:	Mode 2		
Ant.Polar.:	Horizontal		

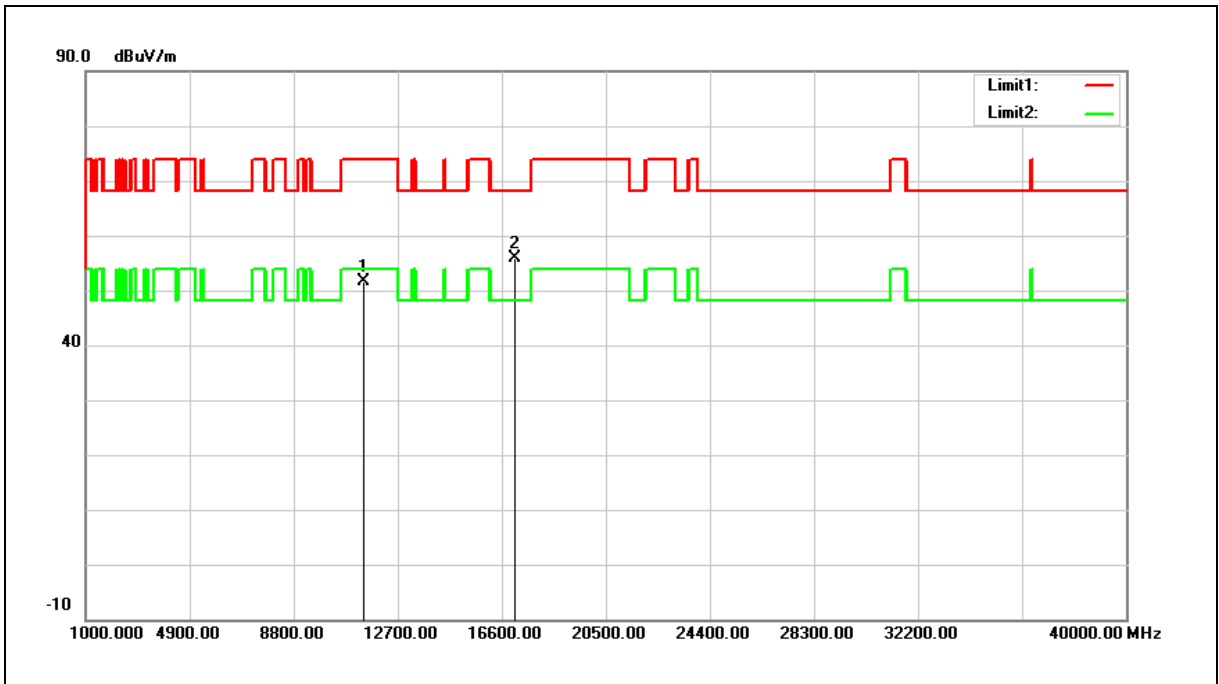

No.	Frequency (MHz)	Reading (dBuV)	Correct Factor (dB/m)	Result (dBuV/m)	Limit (dBuV/m)	Margin (dB)	Remark
1	11400.000	33.12	18.45	51.57	74.00	-22.43	peak
2	17100.000	32.20	23.56	55.76	68.20	-12.44	peak

Note:1.Result (dBuV/m) = Correct Factor (dB/m) + Reading(dBuV).

2.Correction factor (dB/m) = Antenna Factor (dB/m) + Cable loss (dB) – Pre-Amplifier gain (dB).

3.When the peak results are less than average limit, so not need to evaluate the average.

Standard:	FCC Part 15.407	Test Distance:	3 m
Test item:	Harmonic		
Frequency:	5700 MHz		
Mode:	Mode 2		
Ant.Polar.:	Vertical		

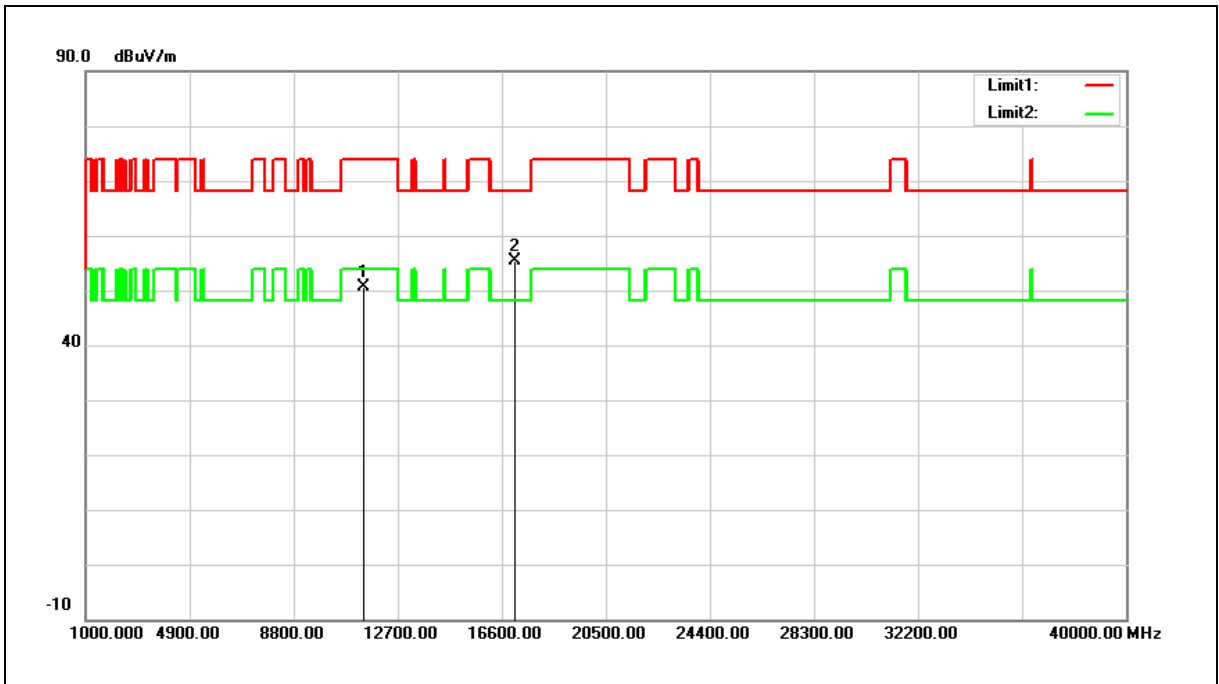

No.	Frequency (MHz)	Reading (dBuV)	Correct Factor (dB/m)	Result (dBuV/m)	Limit (dBuV/m)	Margin (dB)	Remark
1	11400.000	32.08	18.45	50.53	74.00	-23.47	peak
2	17100.000	31.92	23.56	55.48	68.20	-12.72	peak

Note:1.Result (dBuV/m) = Correct Factor (dB/m) + Reading(dBuV).

2.Correction factor (dB/m) = Antenna Factor (dB/m) + Cable loss (dB) – Pre-Amplifier gain (dB).

3.When the peak results are less than average limit, so not need to evaluate the average.

Standard:	FCC Part 15.407	Test Distance:	3 m
Test item:	Harmonic		
Frequency:	5720 MHz		
Mode:	Mode 2		
Ant.Polar.:	Horizontal		

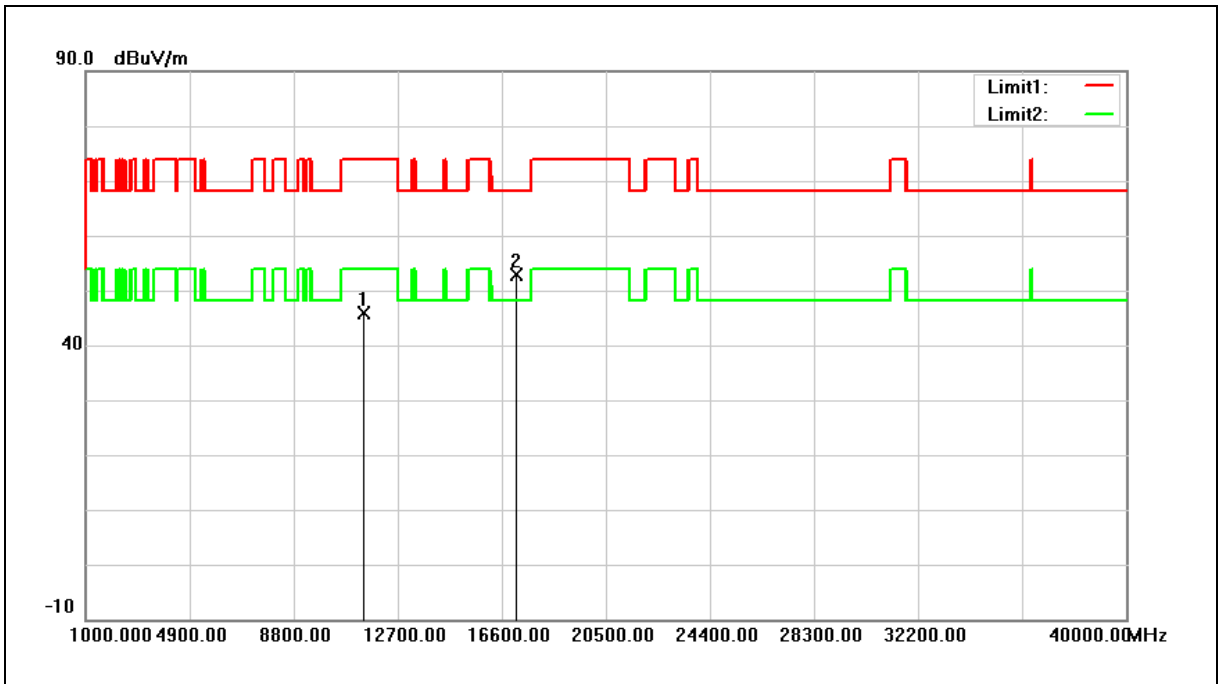

No.	Frequency (MHz)	Reading (dBuV)	Correct Factor (dB/m)	Result (dBuV/m)	Limit (dBuV/m)	Margin (dB)	Remark
1	11440.000	27.32	18.67	45.99	74.00	-28.01	peak
2	17160.000	29.08	23.91	52.99	68.20	-15.21	peak

Note:1.Result (dBuV/m) = Correct Factor (dB/m) + Reading(dBuV).

2.Correction factor (dB/m) = Antenna Factor (dB/m) + Cable loss (dB) – Pre-Amplifier gain (dB).

3.When the peak results are less than average limit, so not need to evaluate the average.

Standard:	FCC Part 15.407	Test Distance:	3 m
Test item:	Harmonic		
Frequency:	5720 MHz		
Mode:	Mode 2		
Ant.Polar.:	Vertical		

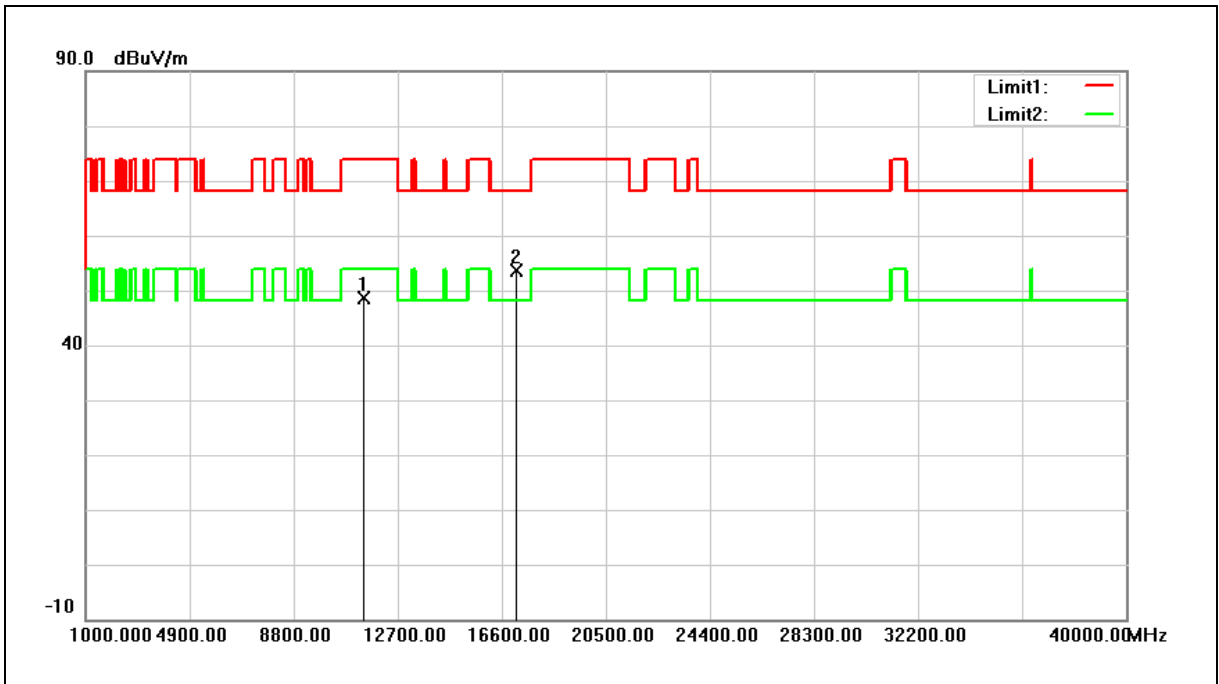

No.	Frequency (MHz)	Reading (dBuV)	Correct Factor (dB/m)	Result (dBuV/m)	Limit (dBuV/m)	Margin (dB)	Remark
1	11440.000	29.92	18.67	48.59	74.00	-25.41	peak
2	17160.000	29.67	23.91	53.58	68.20	-14.62	peak

Note:1.Result (dBuV/m) = Correct Factor (dB/m) + Reading(dBuV).

2.Correction factor (dB/m) = Antenna Factor (dB/m) + Cable loss (dB) – Pre-Amplifier gain (dB).

3.When the peak results are less than average limit, so not need to evaluate the average.

Standard:	FCC Part 15.407	Test Distance:	3 m
Test item:	Harmonic		
Frequency:	5260 MHz		
Mode:	Mode 8		
Ant.Polar.:	Horizontal		

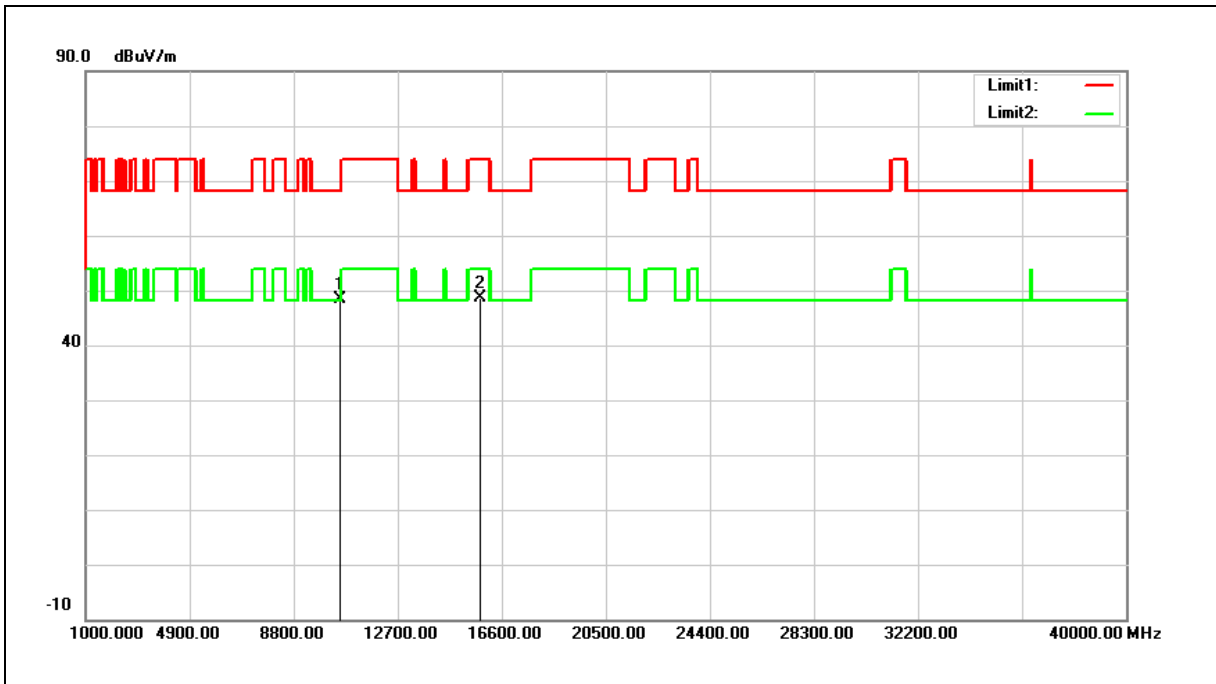

No.	Frequency (MHz)	Reading (dBuV)	Correct Factor (dB/m)	Result (dBuV/m)	Limit (dBuV/m)	Margin (dB)	Remark
1	10520.000	31.06	17.20	48.26	68.20	-19.94	peak
2	15780.000	30.73	17.82	48.55	74.00	-25.45	peak

Note:1.Result (dBuV/m) = Correct Factor (dB/m) + Reading(dBuV).

2.Correction factor (dB/m) = Antenna Factor (dB/m) + Cable loss (dB) – Pre-Amplifier gain (dB).

3.When the peak results are less than average limit, so not need to evaluate the average.

Standard:	FCC Part 15.407	Test Distance:	3 m
Test item:	Harmonic		
Frequency:	5260 MHz		
Mode:	Mode 8		
Ant.Polar.:	Vertical		

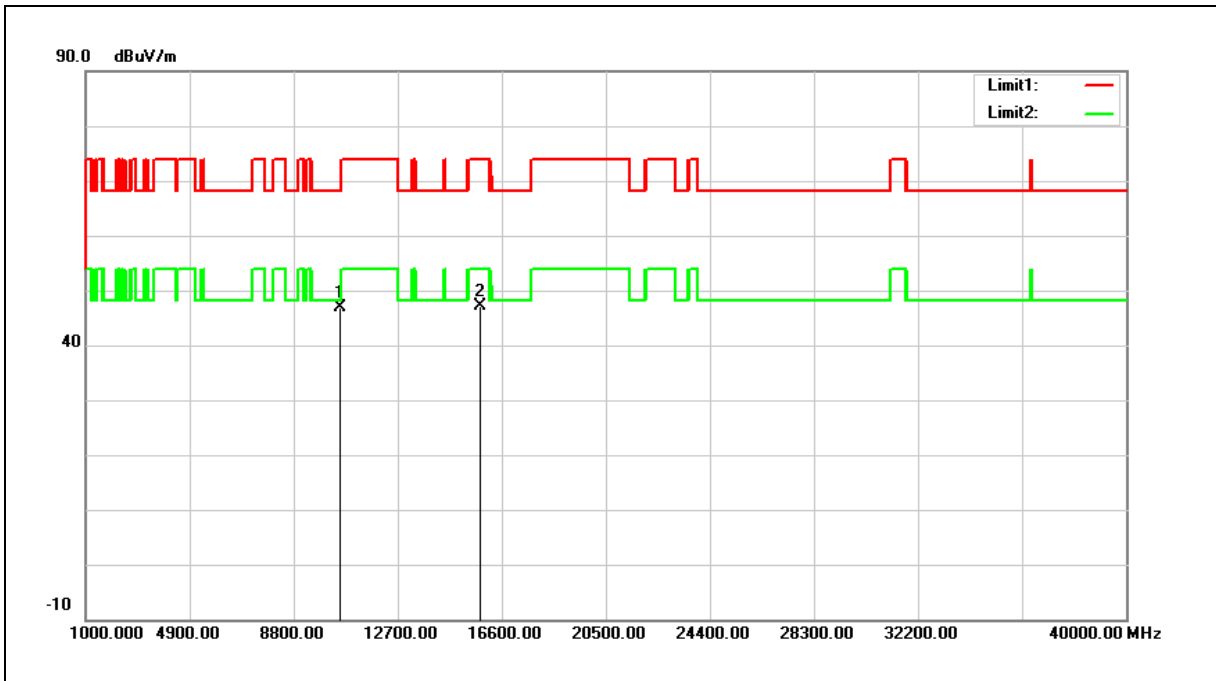

No.	Frequency (MHz)	Reading (dBuV)	Correct Factor (dB/m)	Result (dBuV/m)	Limit (dBuV/m)	Margin (dB)	Remark
1	10520.000	29.60	17.20	46.80	68.20	-21.40	peak
2	15780.000	29.38	17.82	47.20	74.00	-26.80	peak

Note:1.Result (dBuV/m) = Correct Factor (dB/m) + Reading(dBuV).

2.Correction factor (dB/m) = Antenna Factor (dB/m) + Cable loss (dB) – Pre-Amplifier gain (dB).

3.When the peak results are less than average limit, so not need to evaluate the average.

Standard:	FCC Part 15.407	Test Distance:	3 m
Test item:	Harmonic		
Frequency:	5280 MHz		
Mode:	Mode 8		
Ant.Polar.:	Horizontal		

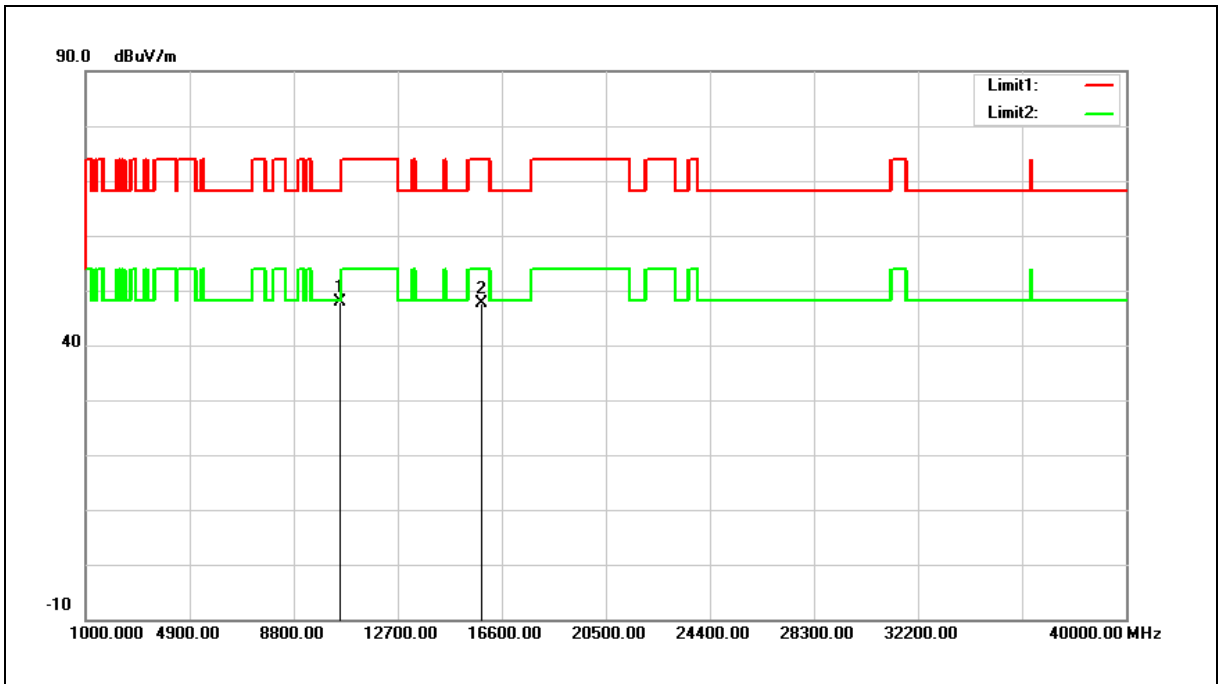

No.	Frequency (MHz)	Reading (dBuV)	Correct Factor (dB/m)	Result (dBuV/m)	Limit (dBuV/m)	Margin (dB)	Remark
1	10560.000	30.50	17.29	47.79	68.20	-20.41	peak
2	15840.000	30.05	17.65	47.70	74.00	-26.30	peak

Note:1.Result (dBuV/m) = Correct Factor (dB/m) + Reading(dBuV).

2.Correction factor (dB/m) = Antenna Factor (dB/m) + Cable loss (dB) – Pre-Amplifier gain (dB).

3.When the peak results are less than average limit, so not need to evaluate the average.

Standard:	FCC Part 15.407	Test Distance:	3 m
Test item:	Harmonic		
Frequency:	5280 MHz		
Mode:	Mode 8		
Ant.Polar.:	Vertical		

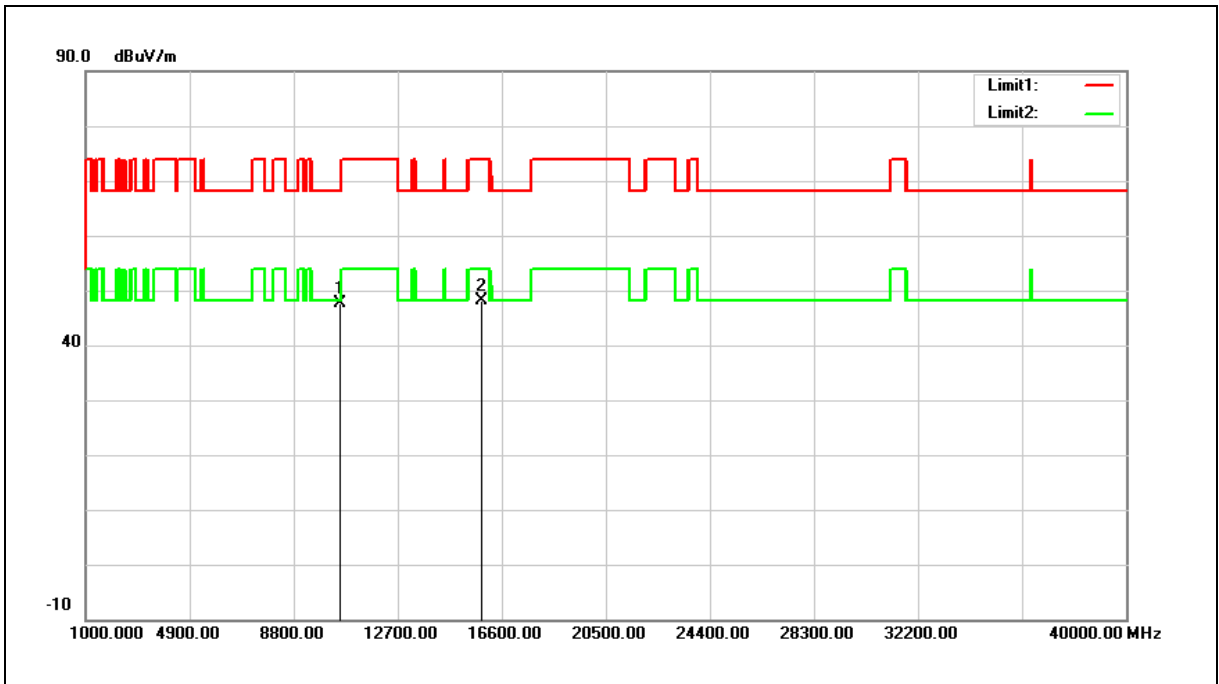

No.	Frequency (MHz)	Reading (dBuV)	Correct Factor (dB/m)	Result (dBuV/m)	Limit (dBuV/m)	Margin (dB)	Remark
1	10560.000	30.22	17.29	47.51	68.20	-20.69	peak
2	15840.000	30.45	17.65	48.10	74.00	-25.90	peak

Note:1.Result (dBuV/m) = Correct Factor (dB/m) + Reading(dBuV).

2.Correction factor (dB/m) = Antenna Factor (dB/m) + Cable loss (dB) – Pre-Amplifier gain (dB).

3.When the peak results are less than average limit, so not need to evaluate the average.

Standard:	FCC Part 15.407	Test Distance:	3 m
Test item:	Harmonic		
Frequency:	5320 MHz		
Mode:	Mode 8		
Ant.Polar.:	Horizontal		

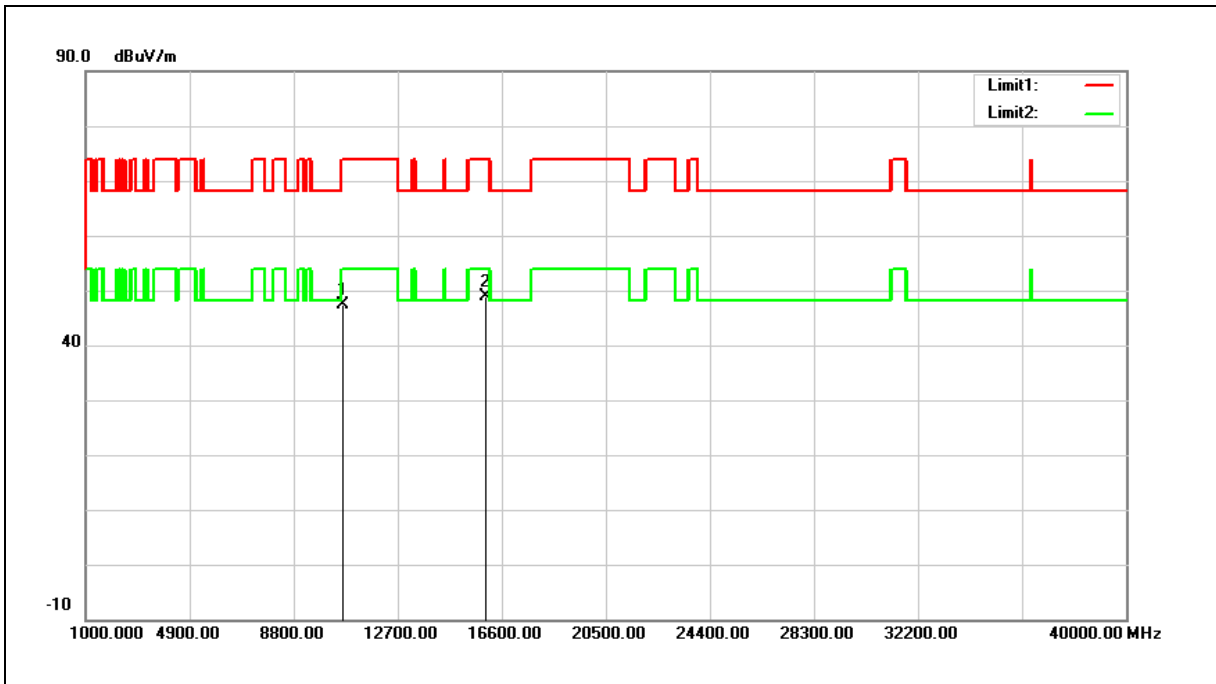

No.	Frequency (MHz)	Reading (dBuV)	Correct Factor (dB/m)	Result (dBuV/m)	Limit (dBuV/m)	Margin (dB)	Remark
1	10640.000	29.86	17.48	47.34	74.00	-26.66	peak
2	15960.000	31.64	17.31	48.95	74.00	-25.05	peak

Note:1.Result (dBuV/m) = Correct Factor (dB/m) + Reading(dBuV).

2.Correction factor (dB/m) = Antenna Factor (dB/m) + Cable loss (dB) – Pre-Amplifier gain (dB).

3.When the peak results are less than average limit, so not need to evaluate the average.

Standard:	FCC Part 15.407	Test Distance:	3 m
Test item:	Harmonic		
Frequency:	5320 MHz		
Mode:	Mode 8		
Ant.Polar.:	Vertical		

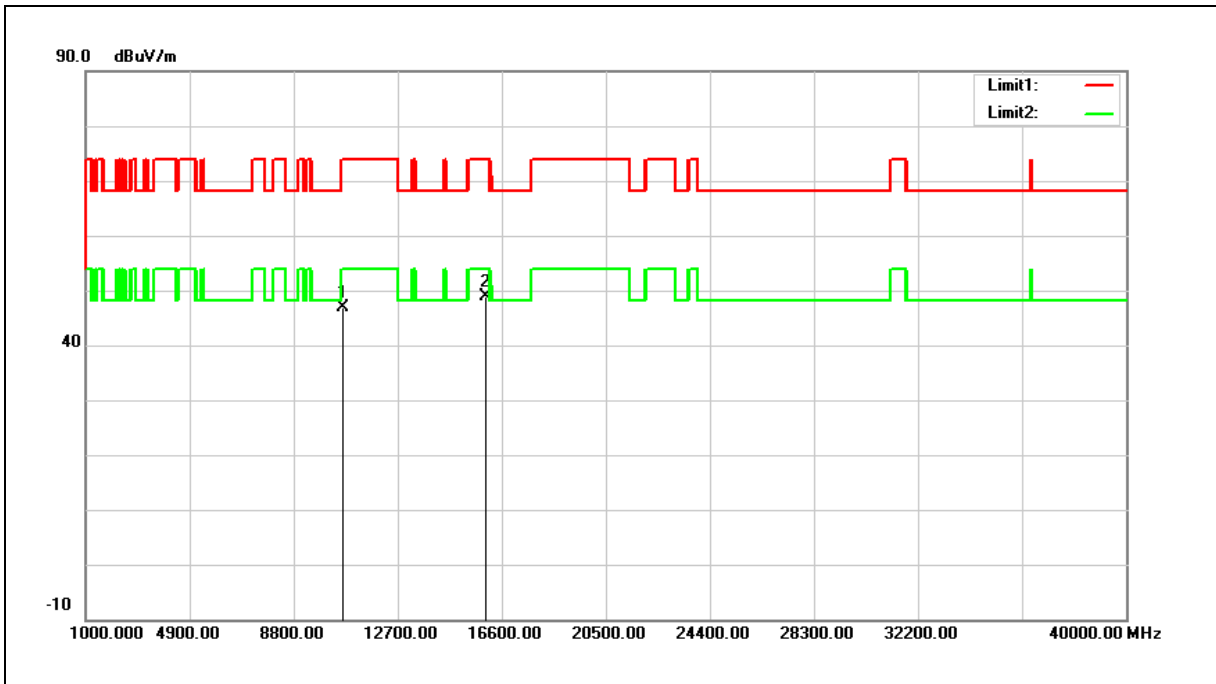

No.	Frequency (MHz)	Reading (dBuV)	Correct Factor (dB/m)	Result (dBuV/m)	Limit (dBuV/m)	Margin (dB)	Remark
1	10640.000	29.44	17.48	46.92	74.00	-27.08	peak
2	15960.000	31.57	17.31	48.88	74.00	-25.12	peak

Note:1.Result (dBuV/m) = Correct Factor (dB/m) + Reading(dBuV).

2.Correction factor (dB/m) = Antenna Factor (dB/m) + Cable loss (dB) – Pre-Amplifier gain (dB).

3.When the peak results are less than average limit, so not need to evaluate the average.

Standard:	FCC Part 15.407	Test Distance:	3 m
Test item:	Harmonic		
Frequency:	5500 MHz		
Mode:	Mode 8		
Ant.Polar.:	Horizontal		

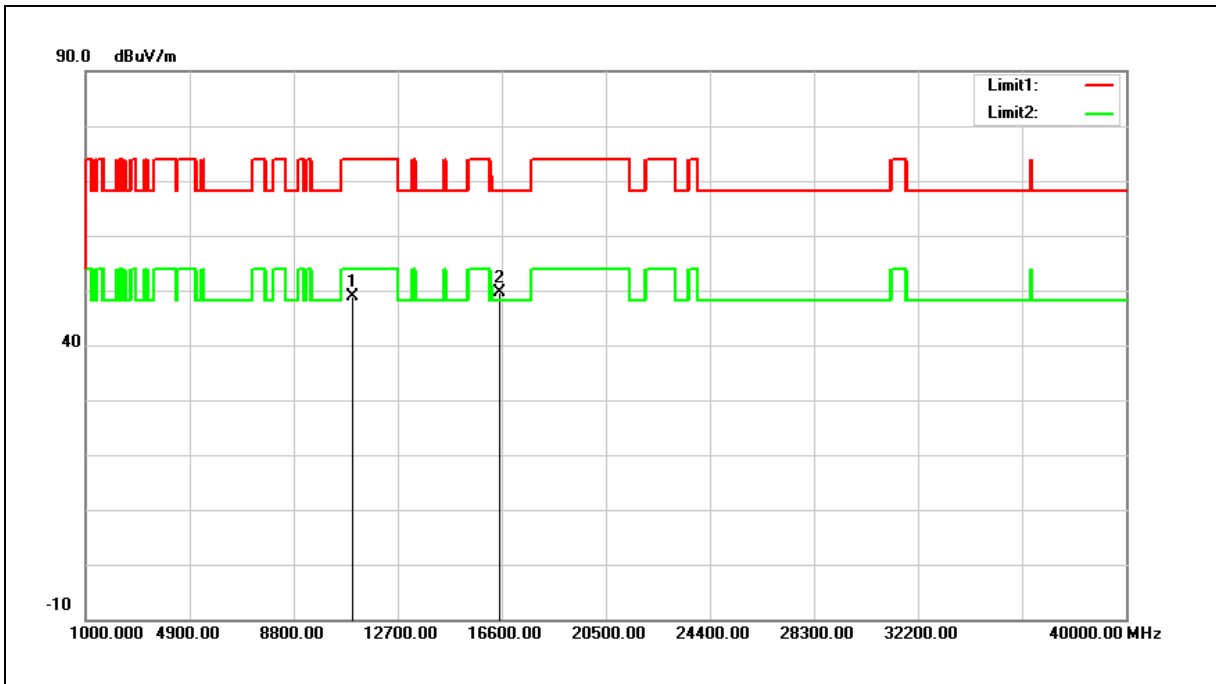

No.	Frequency (MHz)	Reading (dBuV)	Correct Factor (dB/m)	Result (dBuV/m)	Limit (dBuV/m)	Margin (dB)	Remark
1	11000.000	30.53	18.29	48.82	74.00	-25.18	peak
2	16500.000	29.84	19.79	49.63	68.20	-18.57	peak

Note:1.Result (dBuV/m) = Correct Factor (dB/m) + Reading(dBuV).

2.Correction factor (dB/m) = Antenna Factor (dB/m) + Cable loss (dB) – Pre-Amplifier gain (dB).

3.When the peak results are less than average limit, so not need to evaluate the average.

Standard:	FCC Part 15.407	Test Distance:	3 m
Test item:	Harmonic		
Frequency:	5500 MHz		
Mode:	Mode 8		
Ant.Polar.:	Vertical		

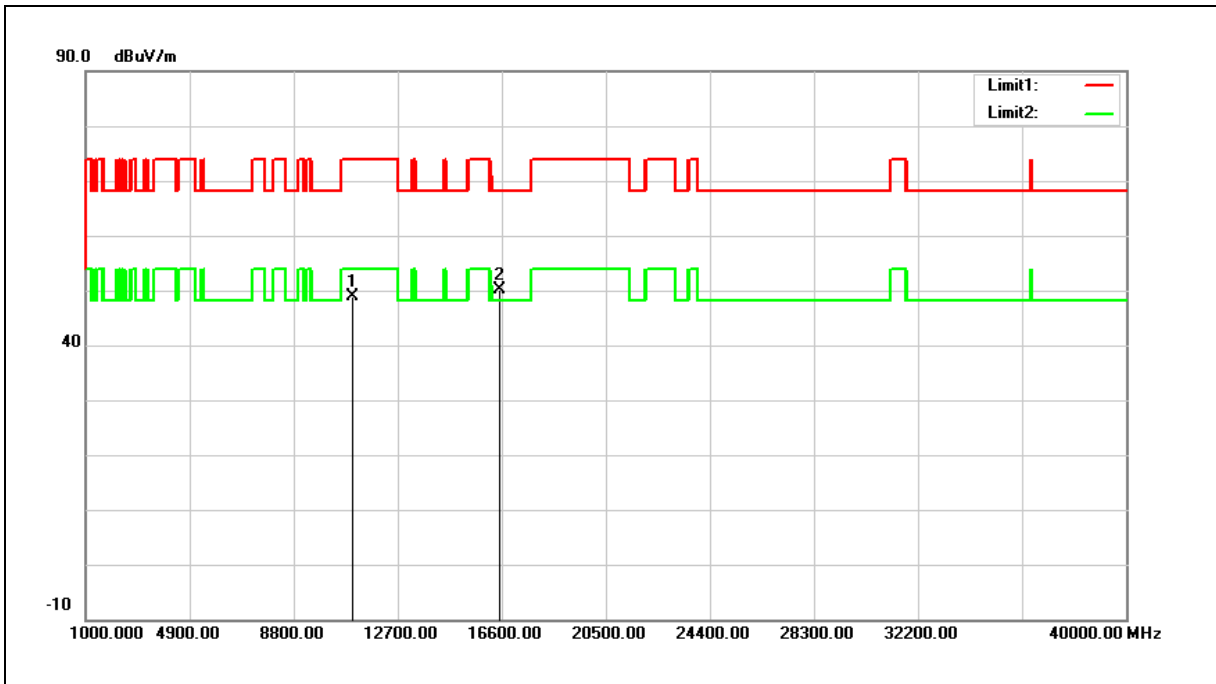

No.	Frequency (MHz)	Reading (dBuV)	Correct Factor (dB/m)	Result (dBuV/m)	Limit (dBuV/m)	Margin (dB)	Remark
1	11000.000	30.55	18.29	48.84	74.00	-25.16	peak
2	16500.000	30.46	19.79	50.25	68.20	-17.95	peak

Note:1.Result (dBuV/m) = Correct Factor (dB/m) + Reading(dBuV).

2.Correction factor (dB/m) = Antenna Factor (dB/m) + Cable loss (dB) – Pre-Amplifier gain (dB).

3.When the peak results are less than average limit, so not need to evaluate the average.

Standard:	FCC Part 15.407	Test Distance:	3 m
Test item:	Harmonic		
Frequency:	5560 MHz		
Mode:	Mode 8		
Ant.Polar.:	Horizontal		

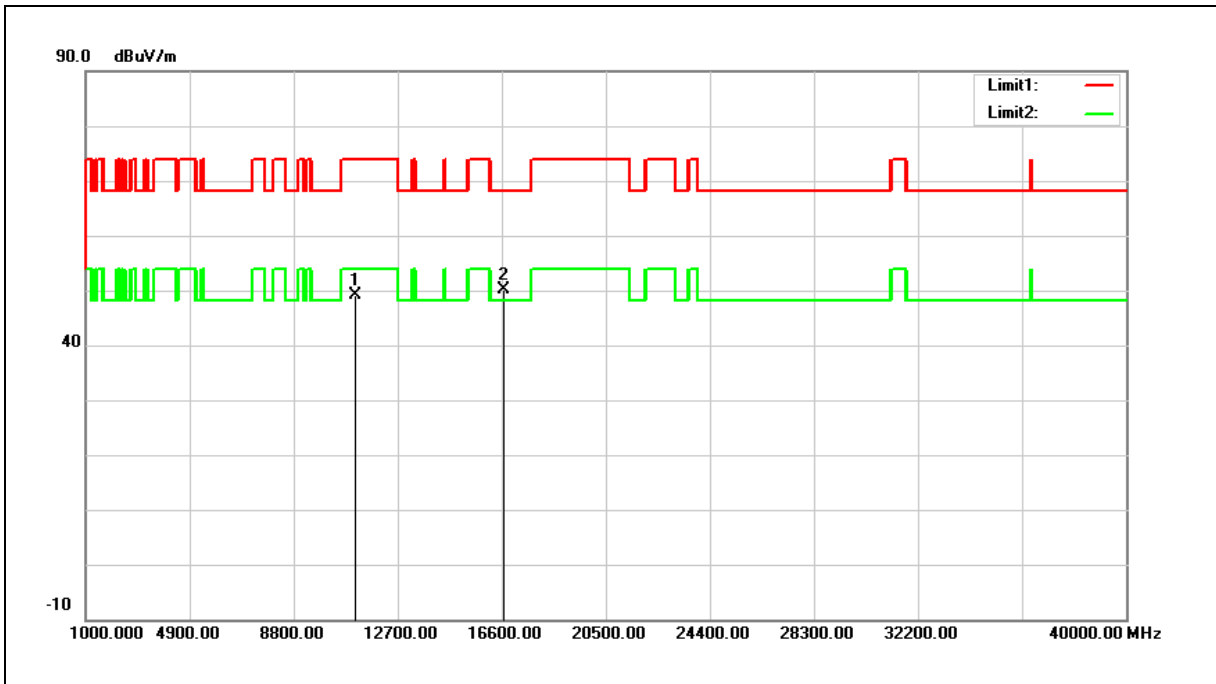

No.	Frequency (MHz)	Reading (dBuV)	Correct Factor (dB/m)	Result (dBuV/m)	Limit (dBuV/m)	Margin (dB)	Remark
1	11120.000	30.69	18.34	49.03	74.00	-24.97	peak
2	16680.000	29.20	20.94	50.14	68.20	-18.06	peak

- Note:1.Result (dBuV/m) = Correct Factor (dB/m) + Reading(dBuV).
 2.Correction factor (dB/m) = Antenna Factor (dB/m) + Cable loss (dB) – Pre-Amplifier gain (dB).
 3.When the peak results are less than average limit, so not need to evaluate the average.

Standard:	FCC Part 15.407	Test Distance:	3 m
Test item:	Harmonic		
Frequency:	5560 MHz		
Mode:	Mode 8		
Ant.Polar.:	Vertical		

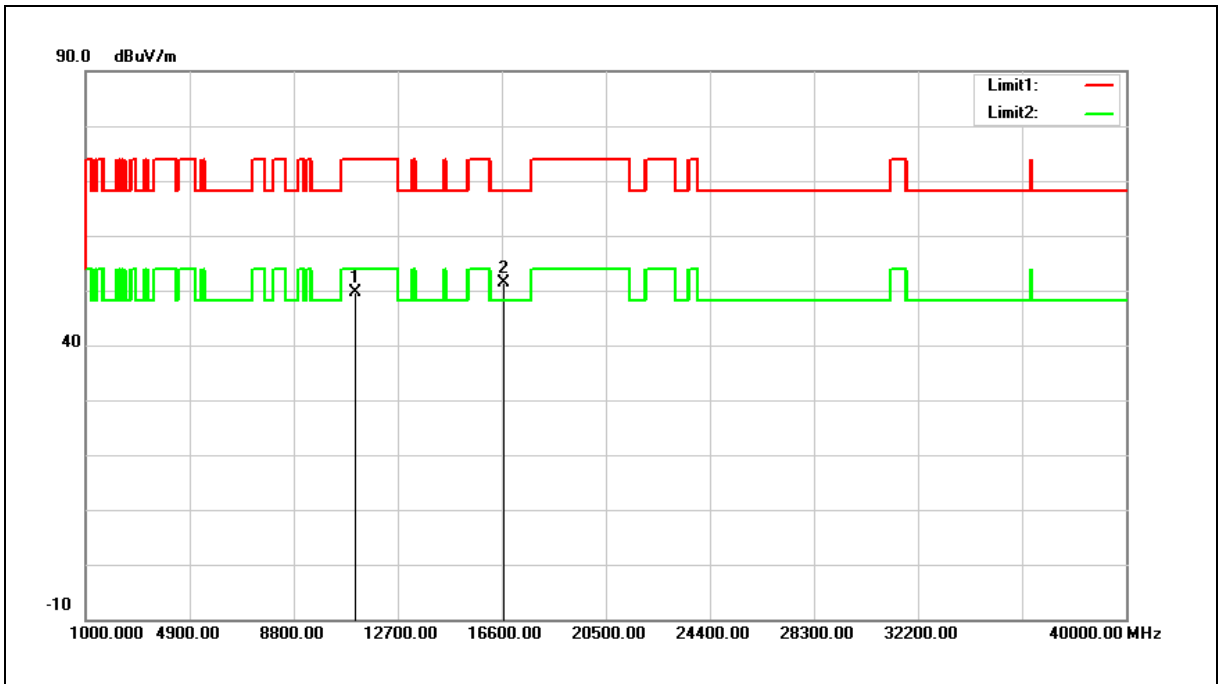

No.	Frequency (MHz)	Reading (dBuV)	Correct Factor (dB/m)	Result (dBuV/m)	Limit (dBuV/m)	Margin (dB)	Remark
1	11120.000	31.29	18.34	49.63	74.00	-24.37	peak
2	16680.000	30.41	20.94	51.35	68.20	-16.85	peak

Note:1.Result (dBuV/m) = Correct Factor (dB/m) + Reading(dBuV).

2.Correction factor (dB/m) = Antenna Factor (dB/m) + Cable loss (dB) – Pre-Amplifier gain (dB).

3.When the peak results are less than average limit, so not need to evaluate the average.

Standard:	FCC Part 15.407	Test Distance:	3 m
Test item:	Harmonic		
Frequency:	5700 MHz		
Mode:	Mode 8		
Ant.Polar.:	Horizontal		

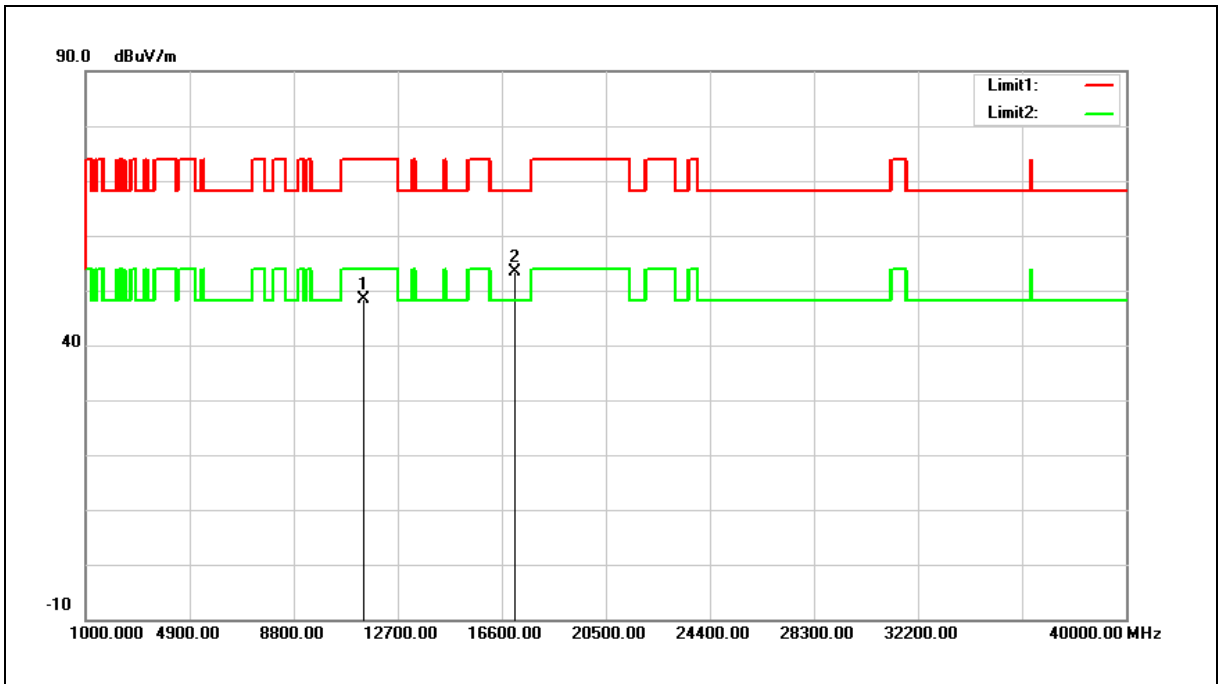

No.	Frequency (MHz)	Reading (dBuV)	Correct Factor (dB/m)	Result (dBuV/m)	Limit (dBuV/m)	Margin (dB)	Remark
1	11400.000	29.92	18.45	48.37	74.00	-25.63	peak
2	17100.000	29.82	23.56	53.38	68.20	-14.82	peak

Note:1.Result (dBuV/m) = Correct Factor (dB/m) + Reading(dBuV).

2.Correction factor (dB/m) = Antenna Factor (dB/m) + Cable loss (dB) – Pre-Amplifier gain (dB).

3.When the peak results are less than average limit, so not need to evaluate the average.

Standard:	FCC Part 15.407	Test Distance:	3 m
Test item:	Harmonic		
Frequency:	5700 MHz		
Mode:	Mode 8		
Ant.Polar.:	Vertical		

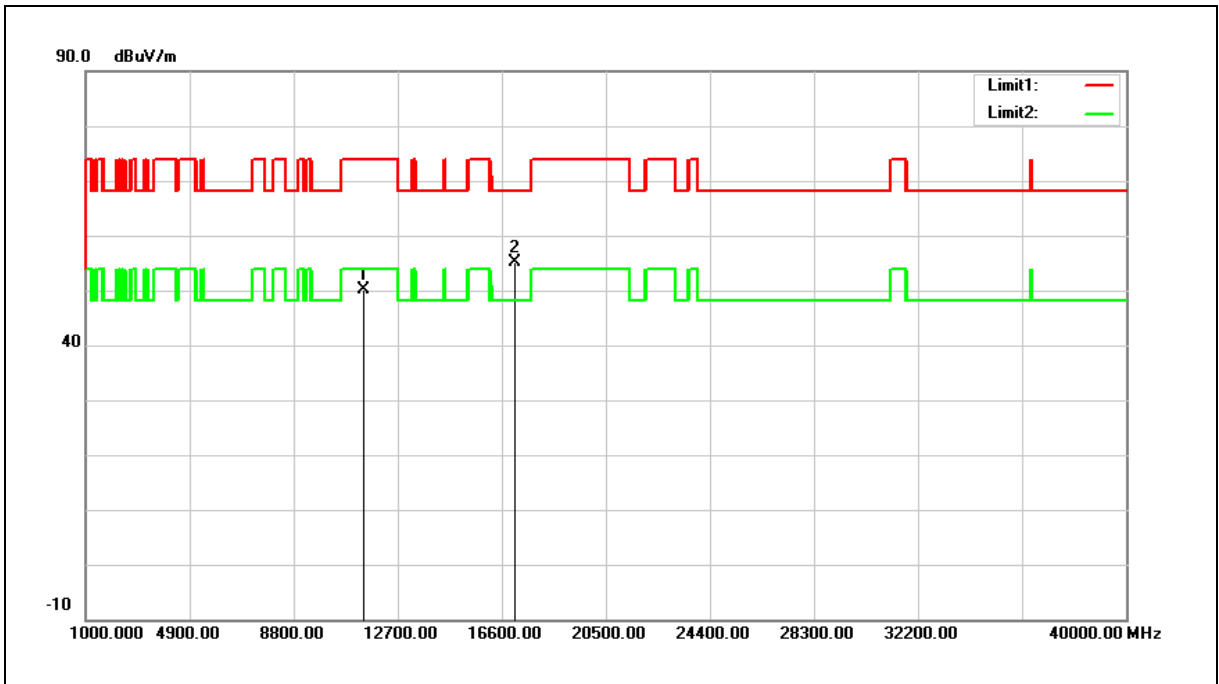

No.	Frequency (MHz)	Reading (dBuV)	Correct Factor (dB/m)	Result (dBuV/m)	Limit (dBuV/m)	Margin (dB)	Remark
1	11400.000	31.74	18.45	50.19	74.00	-23.81	peak
2	17100.000	31.57	23.56	55.13	68.20	-13.07	peak

Note:1.Result (dBuV/m) = Correct Factor (dB/m) + Reading(dBuV).

2.Correction factor (dB/m) = Antenna Factor (dB/m) + Cable loss (dB) – Pre-Amplifier gain (dB).

3.When the peak results are less than average limit, so not need to evaluate the average.

Standard:	FCC Part 15.407	Test Distance:	3 m
Test item:	Harmonic		
Frequency:	5720 MHz		
Mode:	Mode 8		
Ant.Polar.:	Horizontal		

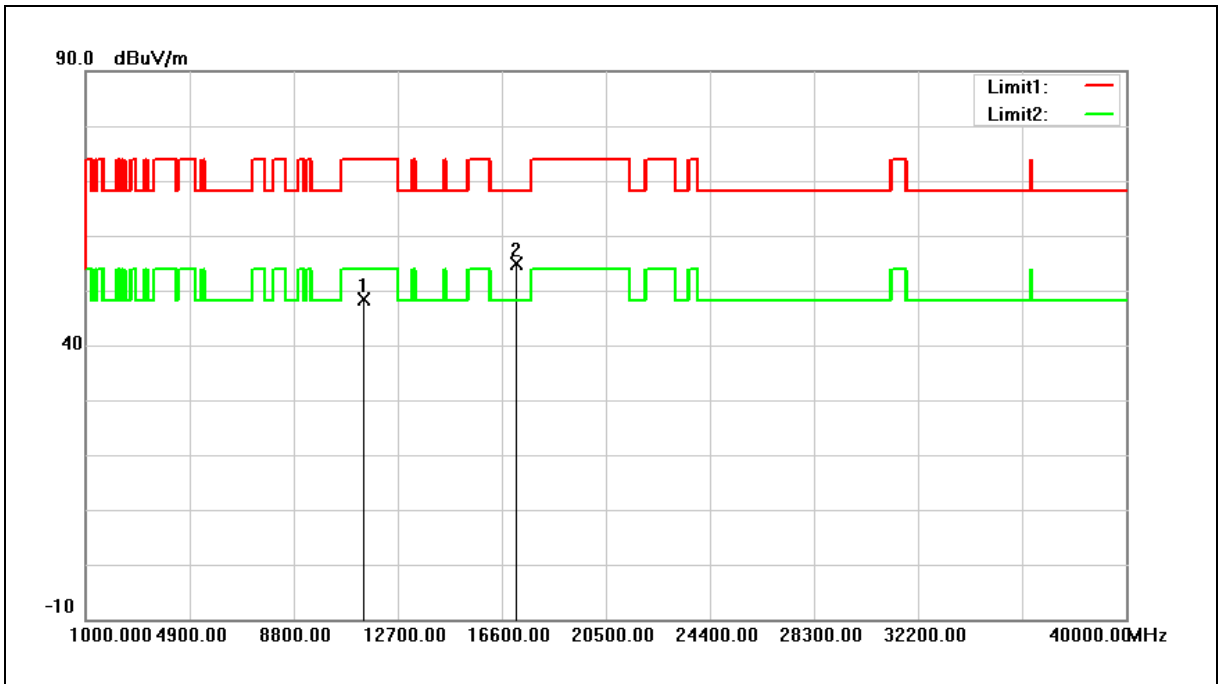

No.	Frequency (MHz)	Reading (dBuV)	Correct Factor (dB/m)	Result (dBuV/m)	Limit (dBuV/m)	Margin (dB)	Remark
1	11440.000	29.89	18.47	48.36	74.00	-25.64	peak
2	17160.000	31.09	23.87	54.96	68.20	-13.24	peak

Note:1.Result (dBuV/m) = Correct Factor (dB/m) + Reading(dBuV).

2.Correction factor (dB/m) = Antenna Factor (dB/m) + Cable loss (dB) – Pre-Amplifier gain (dB).

3.When the peak results are less than average limit, so not need to evaluate the average.

Standard:	FCC Part 15.407	Test Distance:	3 m
Test item:	Harmonic		
Frequency:	5720 MHz		
Mode:	Mode 8		
Ant.Polar.:	Vertical		

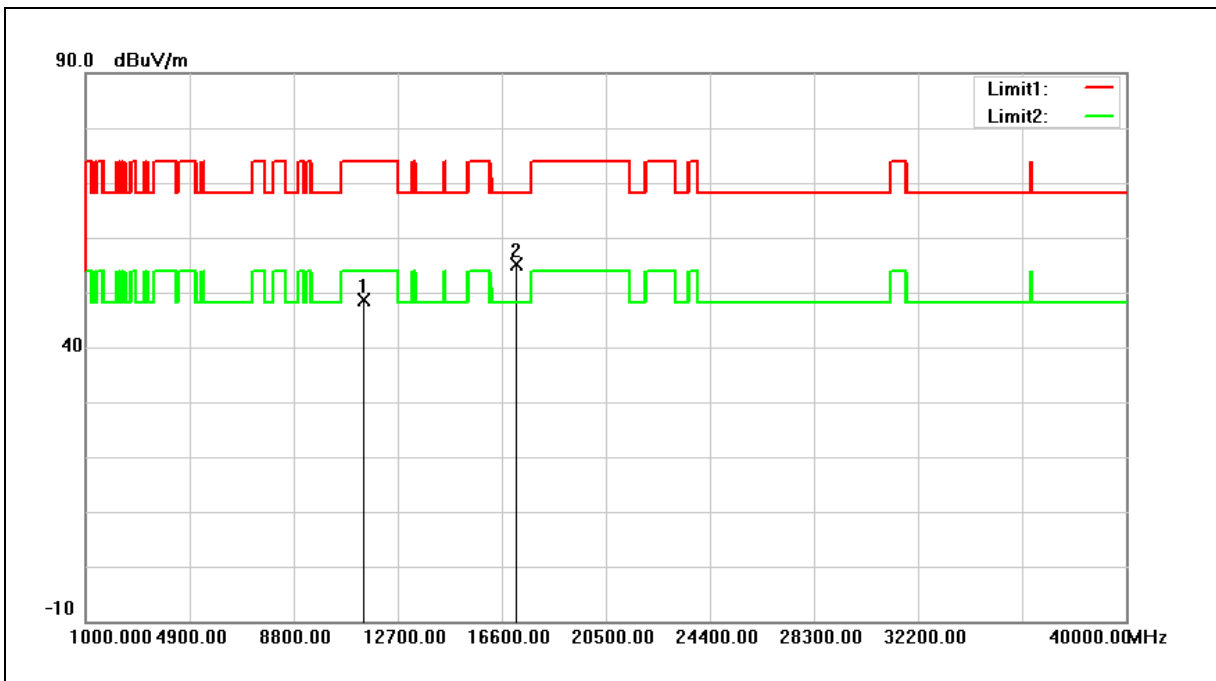

No.	Frequency (MHz)	Reading (dBuV)	Correct Factor (dB/m)	Result (dBuV/m)	Limit (dBuV/m)	Margin (dB)	Remark
1	11440.000	30.12	18.47	48.59	74.00	-25.41	peak
2	17160.000	31.16	23.87	55.03	68.20	-13.17	peak

- Note:1.Result (dBuV/m) = Correct Factor (dB/m) + Reading(dBuV).
- 2.Correction factor (dB/m) = Antenna Factor (dB/m) + Cable loss (dB) – Pre-Amplifier gain (dB).
- 3.When the peak results are less than average limit, so not need to evaluate the average.

Standard:	FCC Part 15.407	Test Distance:	3 m
Test item:	Harmonic		
Frequency:	5270 MHz		
Mode:	Mode 9		
Ant.Polar.:	Horizontal		

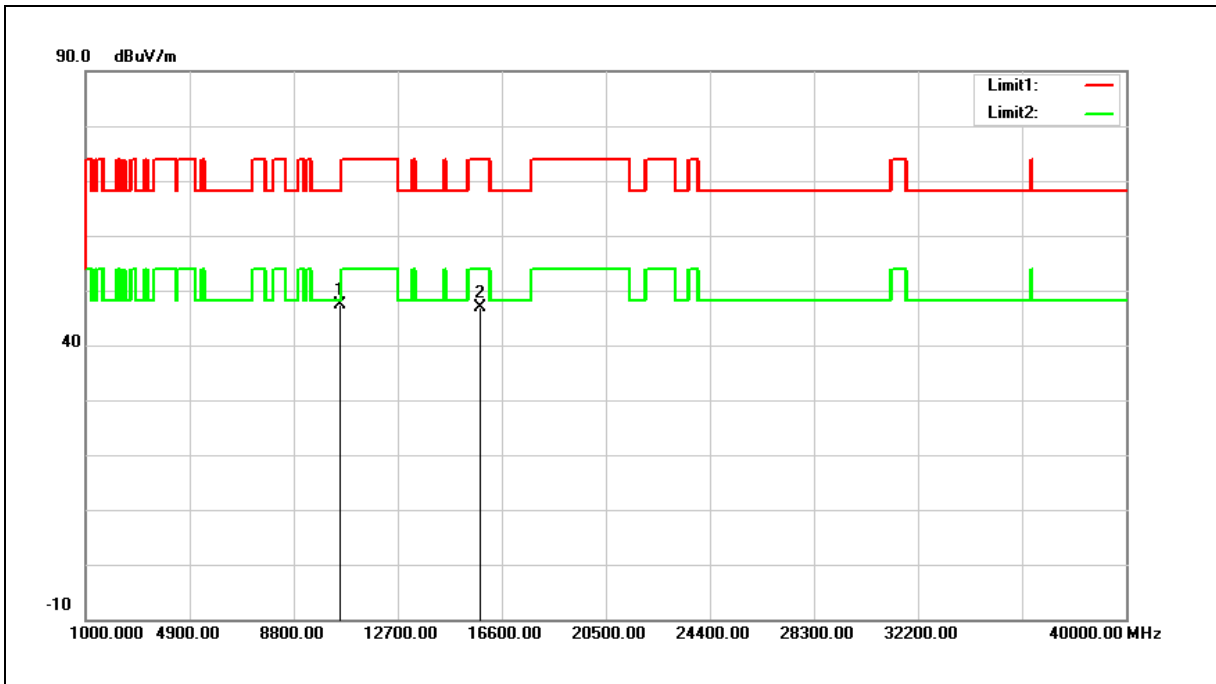

No.	Frequency (MHz)	Reading (dBuV)	Correct Factor (dB/m)	Result (dBuV/m)	Limit (dBuV/m)	Margin (dB)	Remark
1	10540.000	30.11	17.26	47.37	68.20	-20.83	peak
2	15810.000	29.04	17.74	46.78	74.00	-27.22	peak

- Note:1.Result (dBuV/m) = Correct Factor (dB/m) + Reading(dBuV).
 2.Correction factor (dB/m) = Antenna Factor (dB/m) + Cable loss (dB) – Pre-Amplifier gain (dB).
 3.When the peak results are less than average limit, so not need to evaluate the average.

Standard:	FCC Part 15.407	Test Distance:	3 m
Test item:	Harmonic		
Frequency:	5270 MHz		
Mode:	Mode 9		
Ant.Polar.:	Vertical		

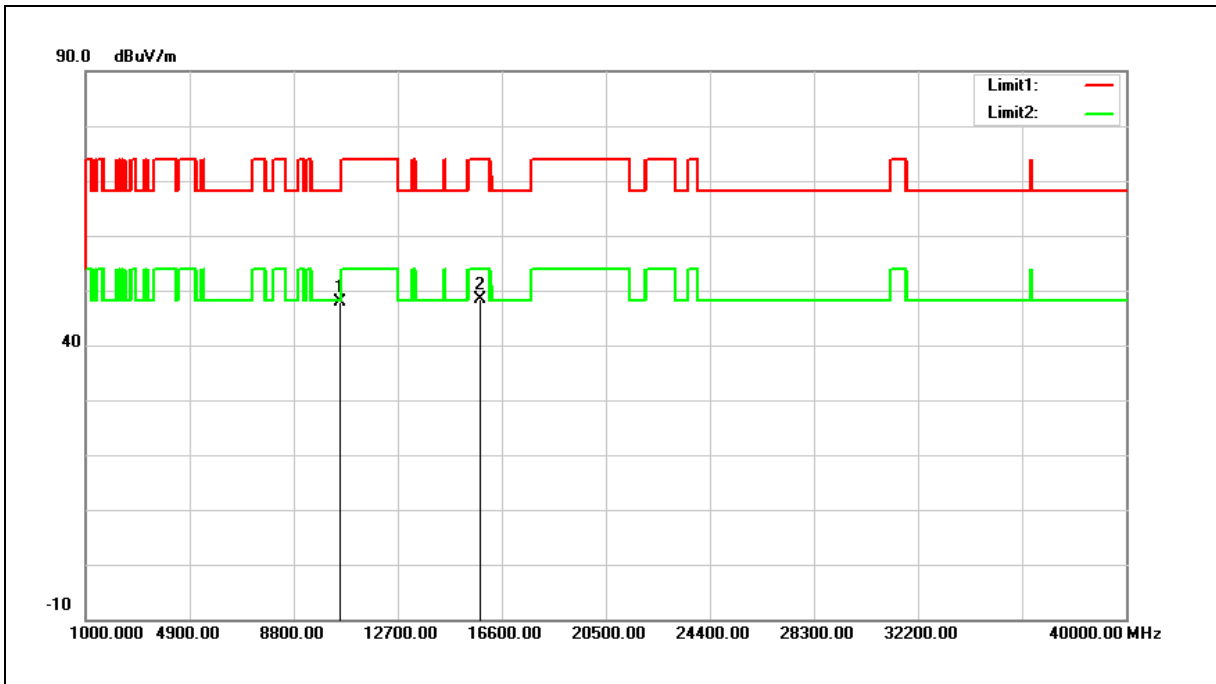

No.	Frequency (MHz)	Reading (dBuV)	Correct Factor (dB/m)	Result (dBuV/m)	Limit (dBuV/m)	Margin (dB)	Remark
1	10540.000	30.58	17.26	47.84	68.20	-20.36	peak
2	15810.000	30.71	17.74	48.45	74.00	-25.55	peak

- Note:1.Result (dBuV/m) = Correct Factor (dB/m) + Reading(dBuV).
 2.Correction factor (dB/m) = Antenna Factor (dB/m) + Cable loss (dB) – Pre-Amplifier gain (dB).
 3.When the peak results are less than average limit, so not need to evaluate the average.

Standard:	FCC Part 15.407	Test Distance:	3 m
Test item:	Harmonic		
Frequency:	5310 MHz		
Mode:	Mode 9		
Ant.Polar.:	Horizontal		

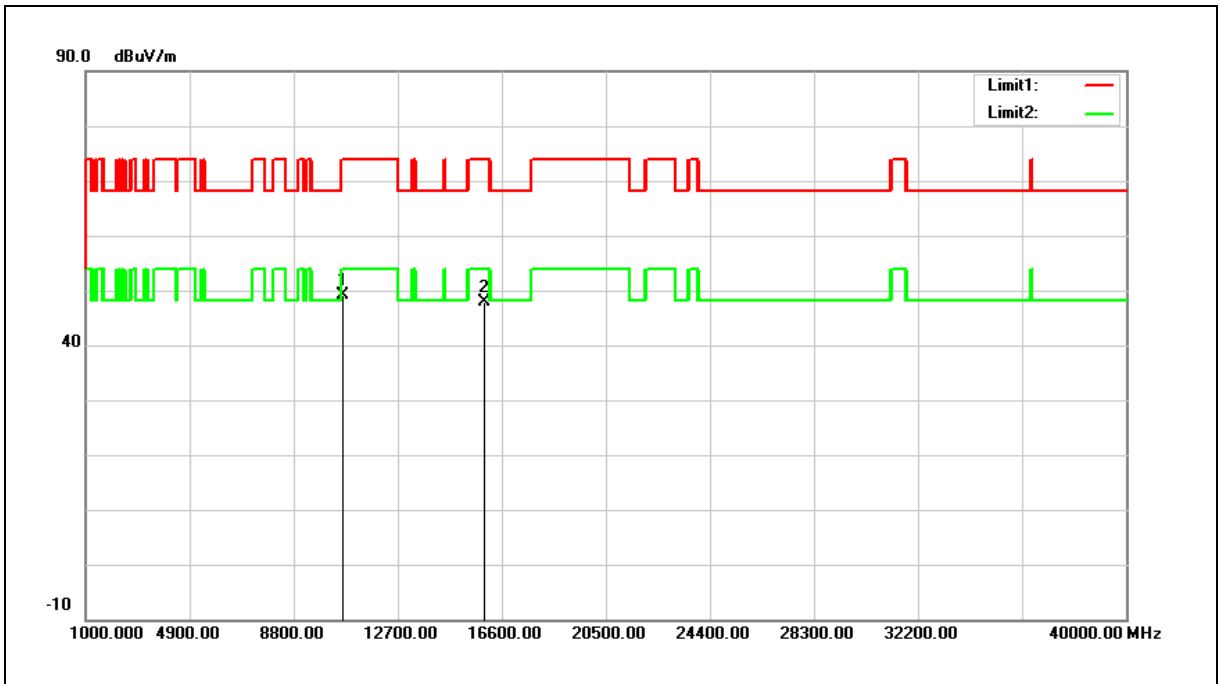

No.	Frequency (MHz)	Reading (dBuV)	Correct Factor (dB/m)	Result (dBuV/m)	Limit (dBuV/m)	Margin (dB)	Remark
1	10620.000	31.64	17.44	49.08	74.00	-24.92	peak
2	15930.000	30.38	17.39	47.77	74.00	-26.23	peak

Note:1.Result (dBuV/m) = Correct Factor (dB/m) + Reading(dBuV).

2.Correction factor (dB/m) = Antenna Factor (dB/m) + Cable loss (dB) – Pre-Amplifier gain (dB).

3.When the peak results are less than average limit, so not need to evaluate the average.

Standard:	FCC Part 15.407	Test Distance:	3 m
Test item:	Harmonic		
Frequency:	5310 MHz		
Mode:	Mode 9		
Ant.Polar.:	Vertical		

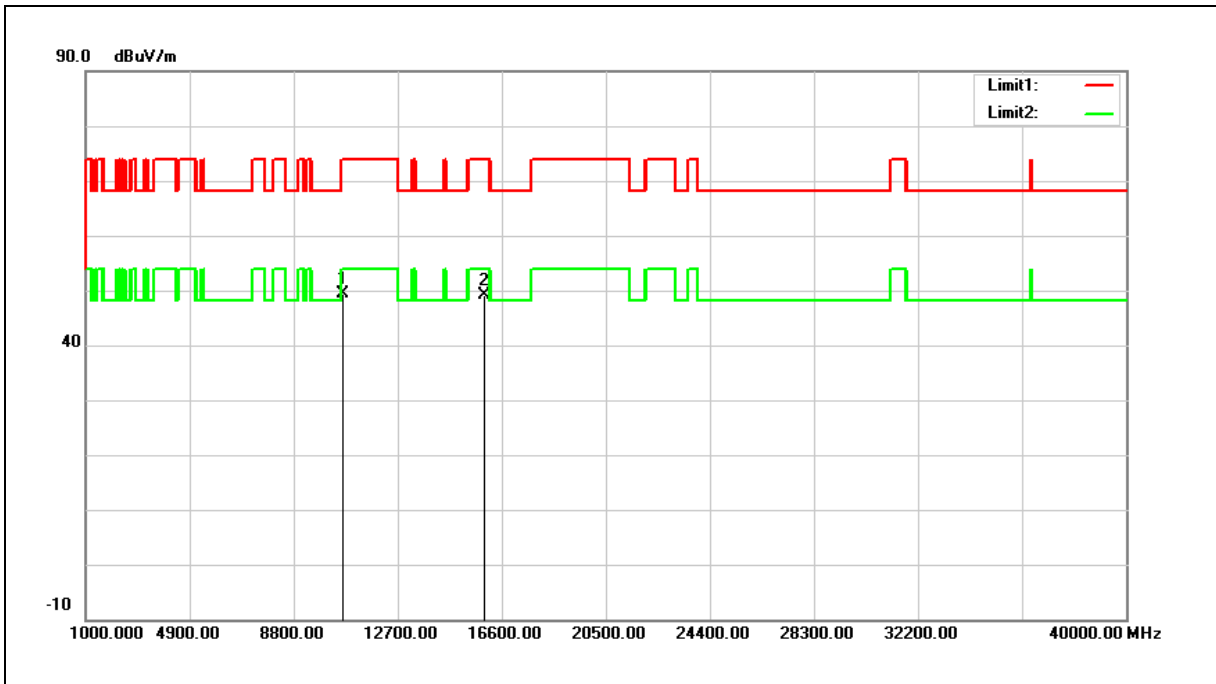

No.	Frequency (MHz)	Reading (dBuV)	Correct Factor (dB/m)	Result (dBuV/m)	Limit (dBuV/m)	Margin (dB)	Remark
1	10620.000	31.89	17.44	49.33	74.00	-24.67	peak
2	15930.000	31.73	17.39	49.12	74.00	-24.88	peak

Note:1.Result (dBuV/m) = Correct Factor (dB/m) + Reading(dBuV).

2.Correction factor (dB/m) = Antenna Factor (dB/m) + Cable loss (dB) – Pre-Amplifier gain (dB).

3.When the peak results are less than average limit, so not need to evaluate the average.

Standard:	FCC Part 15.407	Test Distance:	3 m
Test item:	Harmonic		
Frequency:	5510 MHz		
Mode:	Mode 9		
Ant.Polar.:	Horizontal		

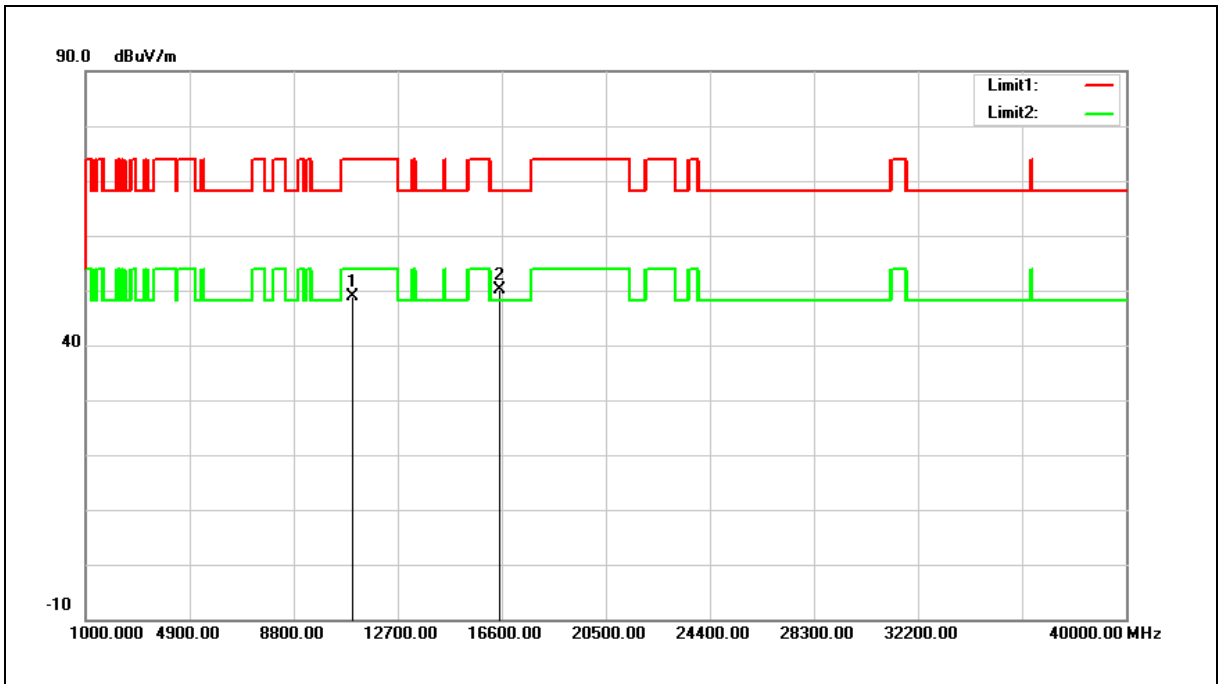

No.	Frequency (MHz)	Reading (dBuV)	Correct Factor (dB/m)	Result (dBuV/m)	Limit (dBuV/m)	Margin (dB)	Remark
1	11020.000	30.64	18.30	48.94	74.00	-25.06	peak
2	16530.000	30.26	19.98	50.24	68.20	-17.96	peak

Note:1.Result (dBuV/m) = Correct Factor (dB/m) + Reading(dBuV).

2.Correction factor (dB/m) = Antenna Factor (dB/m) + Cable loss (dB) – Pre-Amplifier gain (dB).

3.When the peak results are less than average limit, so not need to evaluate the average.

Standard:	FCC Part 15.407	Test Distance:	3 m
Test item:	Harmonic		
Frequency:	5510 MHz		
Mode:	Mode 9		
Ant.Polar.:	Vertical		

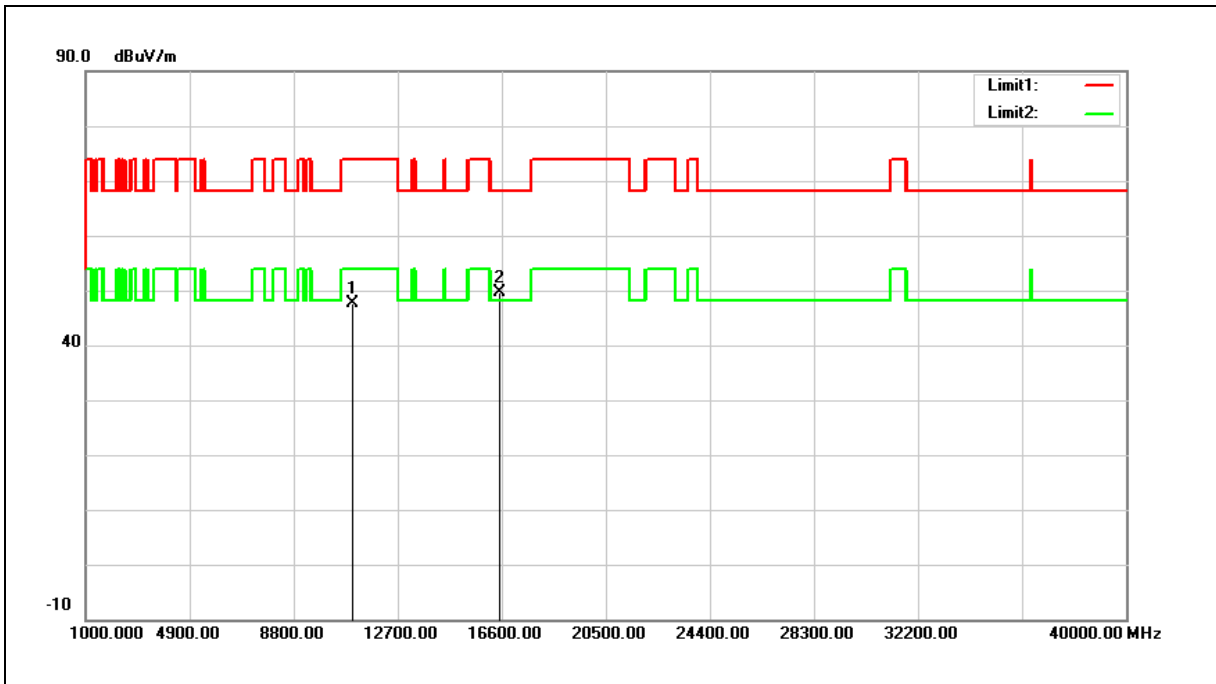

No.	Frequency (MHz)	Reading (dBuV)	Correct Factor (dB/m)	Result (dBuV/m)	Limit (dBuV/m)	Margin (dB)	Remark
1	11020.000	29.43	18.30	47.73	74.00	-26.27	peak
2	16530.000	29.56	19.98	49.54	68.20	-18.66	peak

Note:1.Result (dBuV/m) = Correct Factor (dB/m) + Reading(dBuV).

2.Correction factor (dB/m) = Antenna Factor (dB/m) + Cable loss (dB) – Pre-Amplifier gain (dB).

3.When the peak results are less than average limit, so not need to evaluate the average.

Standard:	FCC Part 15.407	Test Distance:	3 m
Test item:	Harmonic		
Frequency:	5550 MHz		
Mode:	Mode 9		
Ant.Polar.:	Horizontal		

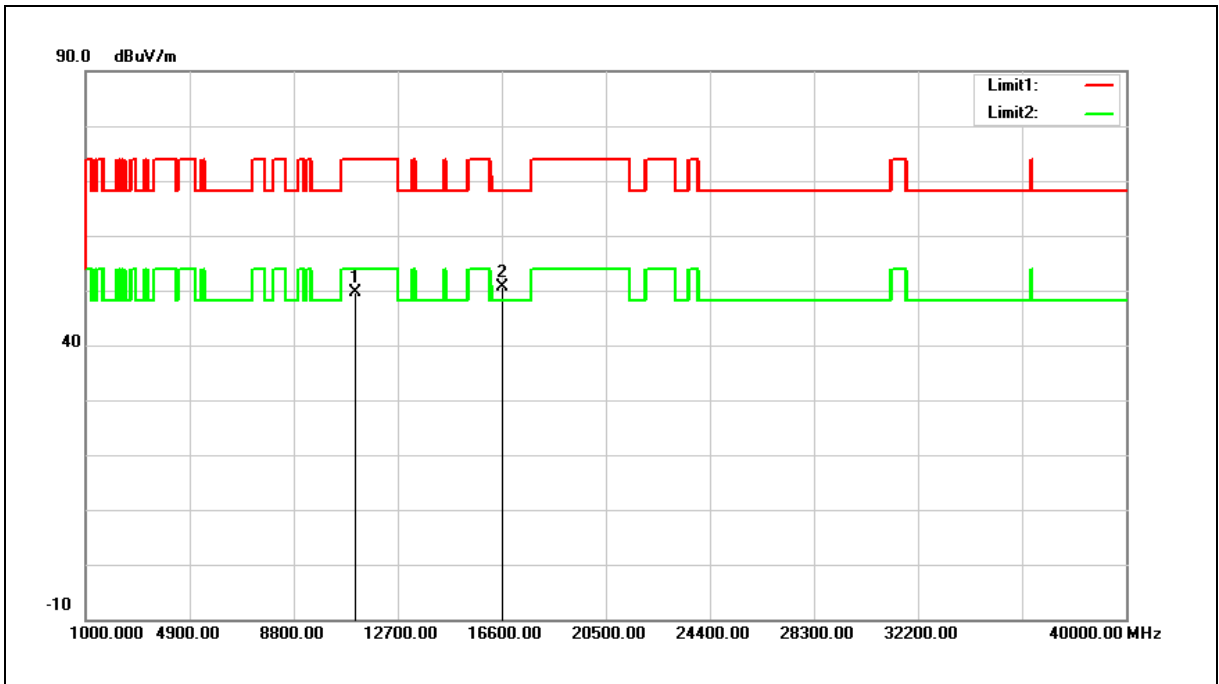

No.	Frequency (MHz)	Reading (dBuV)	Correct Factor (dB/m)	Result (dBuV/m)	Limit (dBuV/m)	Margin (dB)	Remark
1	11100.000	31.42	18.33	49.75	74.00	-24.25	peak
2	16650.000	29.83	20.76	50.59	68.20	-17.61	peak

Note:1.Result (dBuV/m) = Correct Factor (dB/m) + Reading(dBuV).

2.Correction factor (dB/m) = Antenna Factor (dB/m) + Cable loss (dB) – Pre-Amplifier gain (dB).

3.When the peak results are less than average limit, so not need to evaluate the average.

Standard:	FCC Part 15.407	Test Distance:	3 m
Test item:	Harmonic		
Frequency:	5550 MHz		
Mode:	Mode 9		
Ant.Polar.:	Vertical		

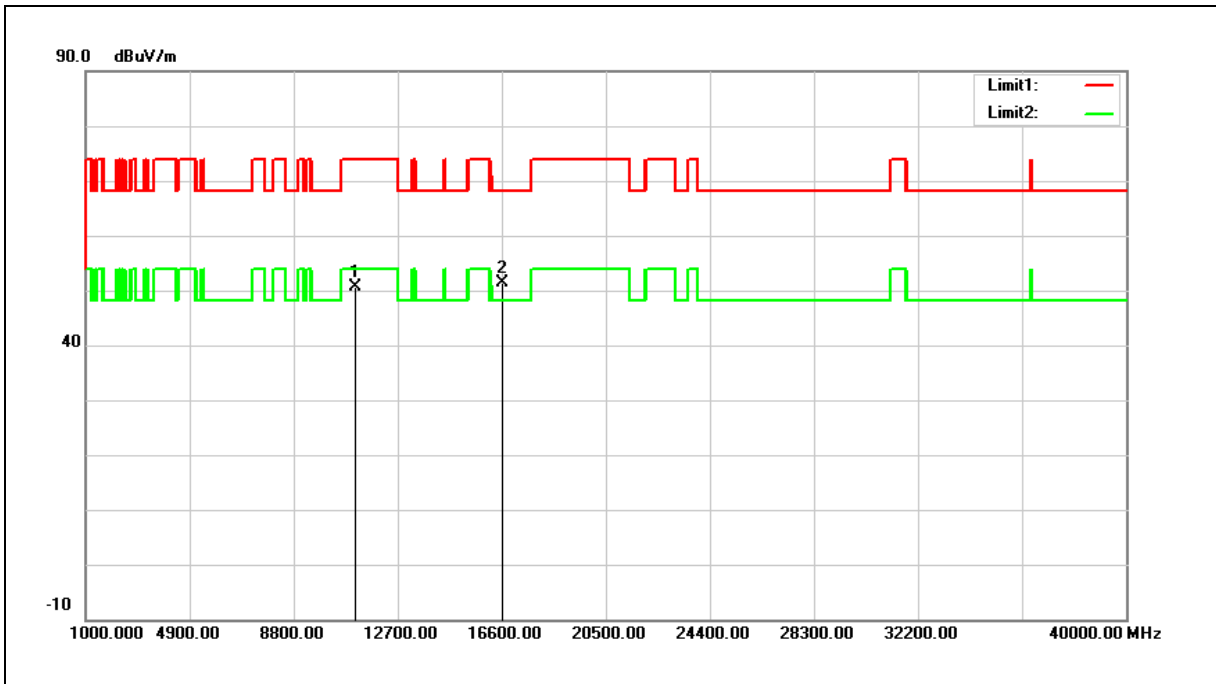

No.	Frequency (MHz)	Reading (dBuV)	Correct Factor (dB/m)	Result (dBuV/m)	Limit (dBuV/m)	Margin (dB)	Remark
1	11100.000	32.34	18.33	50.67	74.00	-23.33	peak
2	16650.000	30.67	20.76	51.43	68.20	-16.77	peak

Note:1.Result (dBuV/m) = Correct Factor (dB/m) + Reading(dBuV).

2.Correction factor (dB/m) = Antenna Factor (dB/m) + Cable loss (dB) – Pre-Amplifier gain (dB).

3.When the peak results are less than average limit, so not need to evaluate the average.

Standard:	FCC Part 15.407	Test Distance:	3 m
Test item:	Harmonic		
Frequency:	5670 MHz		
Mode:	Mode 9		
Ant.Polar.:	Horizontal		

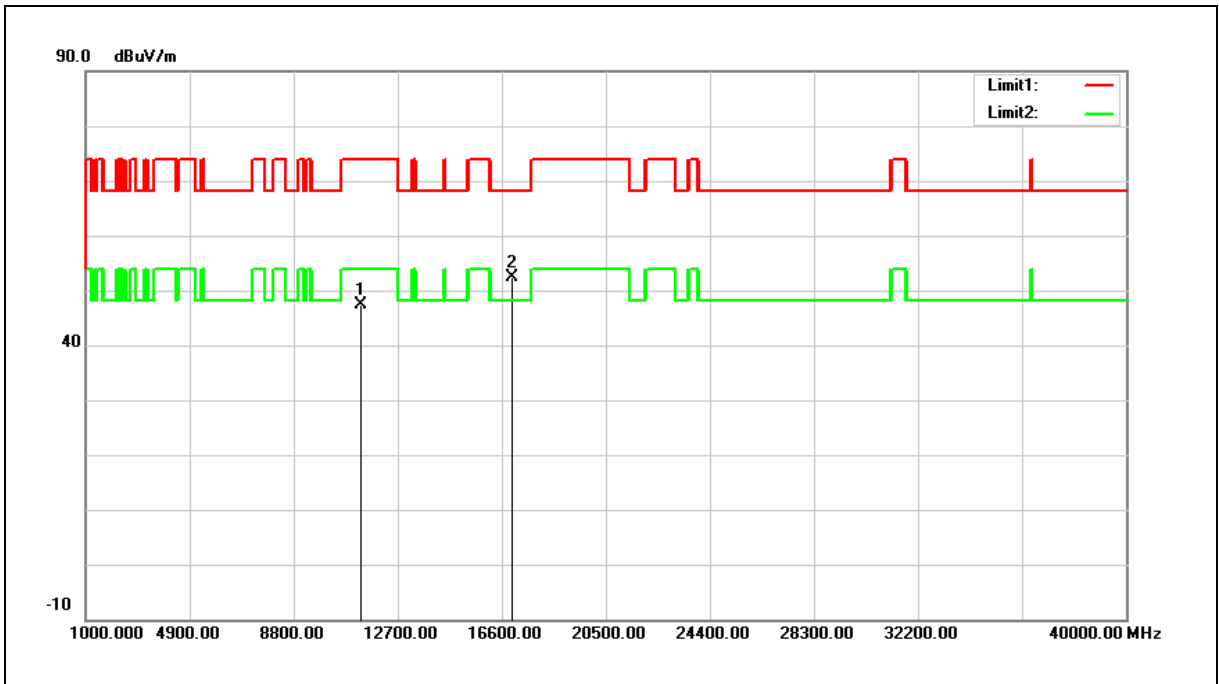

No.	Frequency (MHz)	Reading (dBuV)	Correct Factor (dB/m)	Result (dBuV/m)	Limit (dBuV/m)	Margin (dB)	Remark
1	11340.000	29.05	18.43	47.48	74.00	-26.52	peak
2	17010.000	29.33	23.06	52.39	68.20	-15.81	peak

Note:1.Result (dBuV/m) = Correct Factor (dB/m) + Reading(dBuV).

2.Correction factor (dB/m) = Antenna Factor (dB/m) + Cable loss (dB) – Pre-Amplifier gain (dB).

3.When the peak results are less than average limit, so not need to evaluate the average.

Standard:	FCC Part 15.407	Test Distance:	3 m
Test item:	Harmonic		
Frequency:	5670 MHz		
Mode:	Mode 9		
Ant.Polar.:	Vertical		

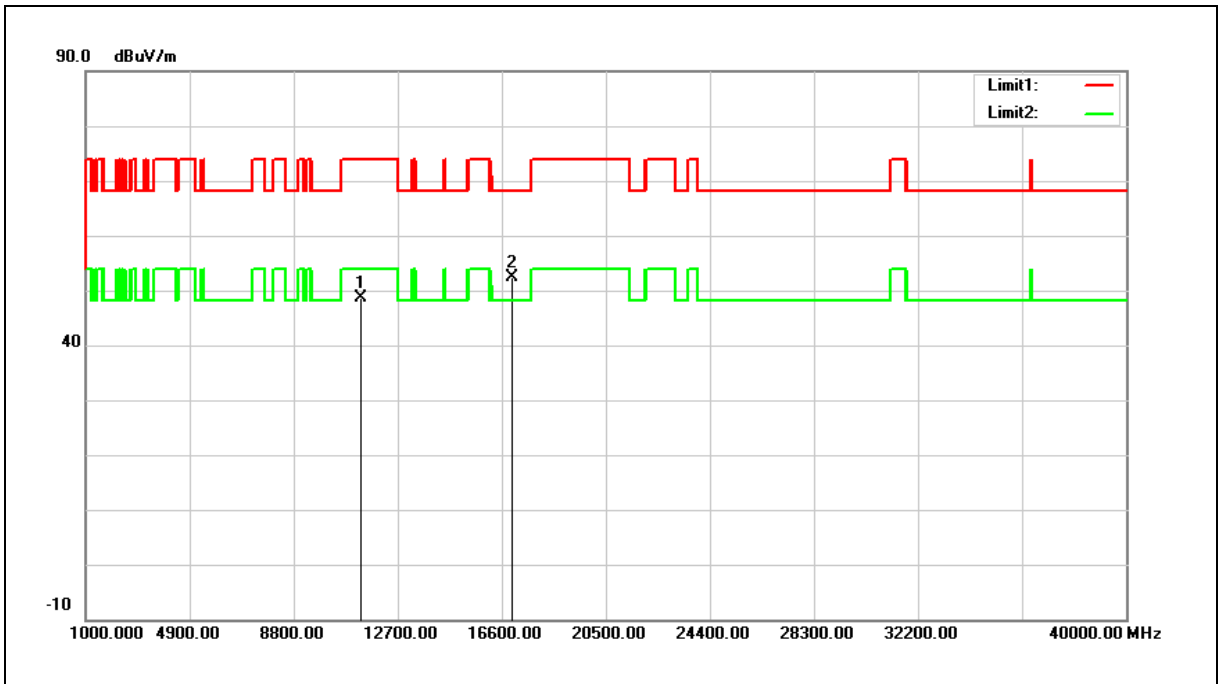

No.	Frequency (MHz)	Reading (dBuV)	Correct Factor (dB/m)	Result (dBuV/m)	Limit (dBuV/m)	Margin (dB)	Remark
1	11340.000	30.22	18.43	48.65	74.00	-25.35	peak
2	17010.000	29.36	23.06	52.42	68.20	-15.78	peak

Note:1.Result (dBuV/m) = Correct Factor (dB/m) + Reading(dBuV).

2.Correction factor (dB/m) = Antenna Factor (dB/m) + Cable loss (dB) – Pre-Amplifier gain (dB).

3.When the peak results are less than average limit, so not need to evaluate the average.

Standard:	FCC Part 15.407	Test Distance:	3 m
Test item:	Harmonic		
Frequency:	5710 MHz		
Mode:	Mode 9		
Ant.Polar.:	Horizontal		

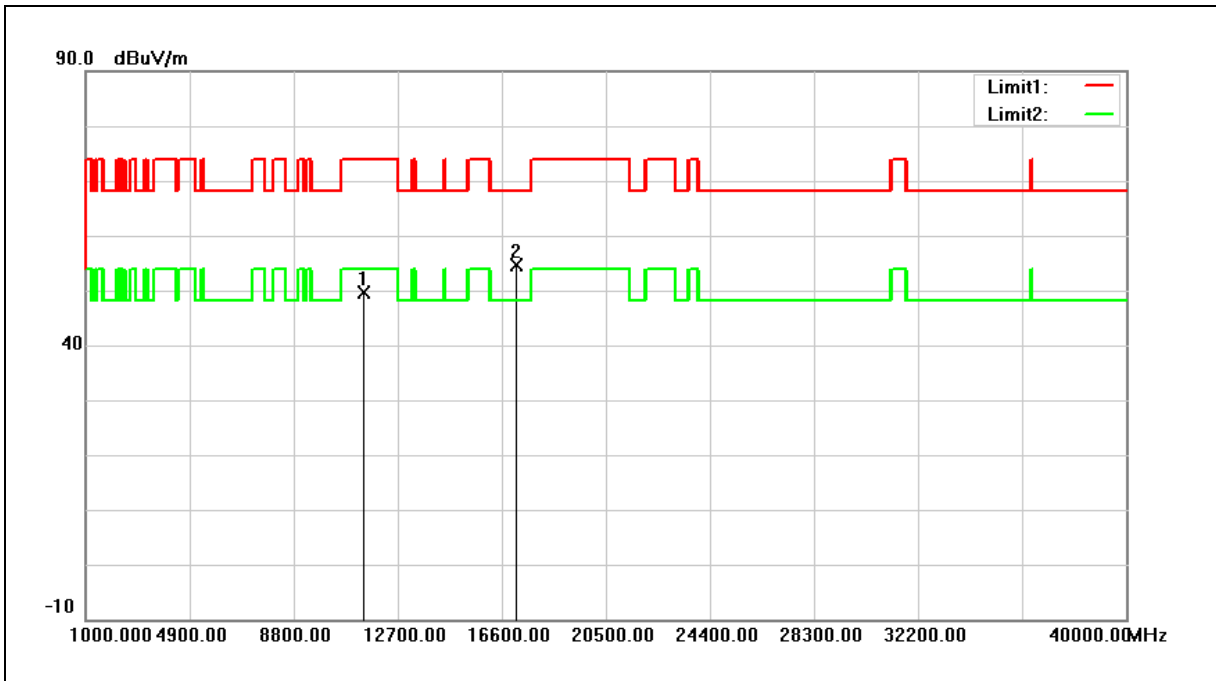

No.	Frequency (MHz)	Reading (dBuV)	Correct Factor (dB/m)	Result (dBuV/m)	Limit (dBuV/m)	Margin (dB)	Remark
1	11420.000	31.08	18.47	49.55	74.00	-24.45	peak
2	17130.000	30.81	23.71	54.52	68.20	-13.68	peak

Note:1.Result (dBuV/m) = Correct Factor (dB/m) + Reading(dBuV).

2.Correction factor (dB/m) = Antenna Factor (dB/m) + Cable loss (dB) – Pre-Amplifier gain (dB).

3.When the peak results are less than average limit, so not need to evaluate the average.

Standard:	FCC Part 15.407	Test Distance:	3 m
Test item:	Harmonic		
Frequency:	5710 MHz		
Mode:	Mode 9		
Ant.Polar.:	Vertical		

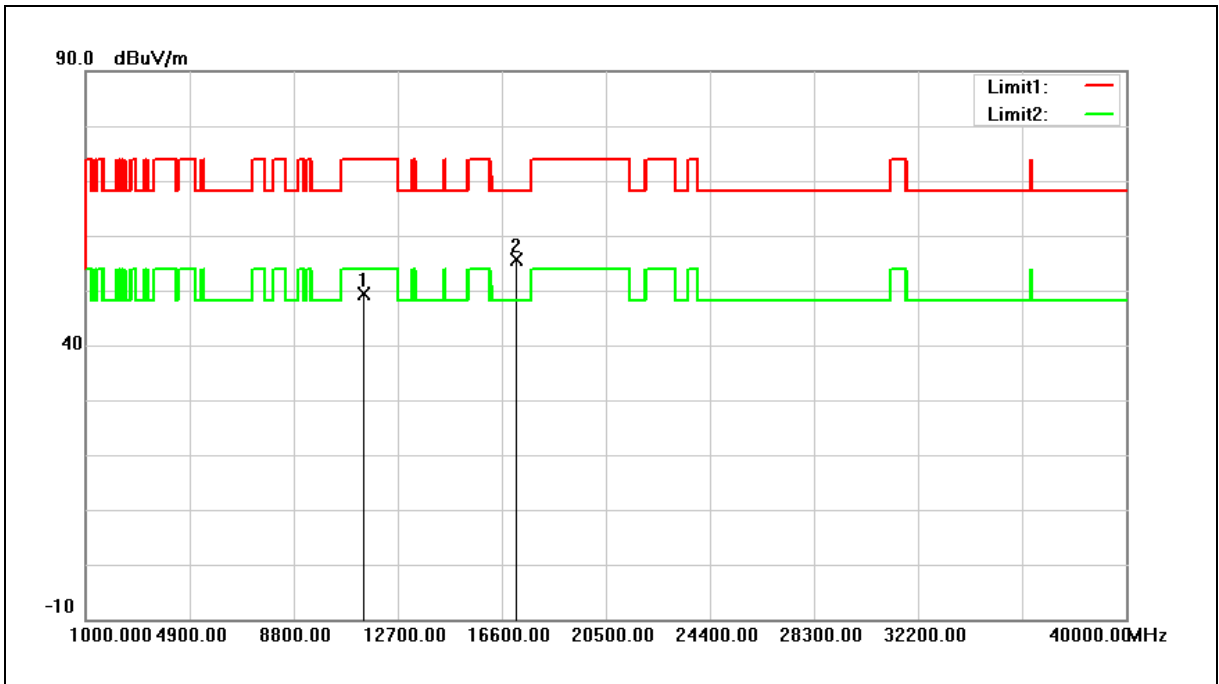

No.	Frequency (MHz)	Reading (dBuV)	Correct Factor (dB/m)	Result (dBuV/m)	Limit (dBuV/m)	Margin (dB)	Remark
1	11420.000	30.98	18.47	49.45	74.00	-24.55	peak
2	17130.000	31.93	23.71	55.64	68.20	-12.56	peak

Note:1.Result (dBuV/m) = Correct Factor (dB/m) + Reading(dBuV).

2.Correction factor (dB/m) = Antenna Factor (dB/m) + Cable loss (dB) – Pre-Amplifier gain (dB).

3.When the peak results are less than average limit, so not need to evaluate the average.

Standard:	FCC Part 15.407	Test Distance:	3 m
Test item:	Harmonic		
Frequency:	5290 MHz		
Mode:	Mode 10		
Ant.Polar.:	Horizontal		

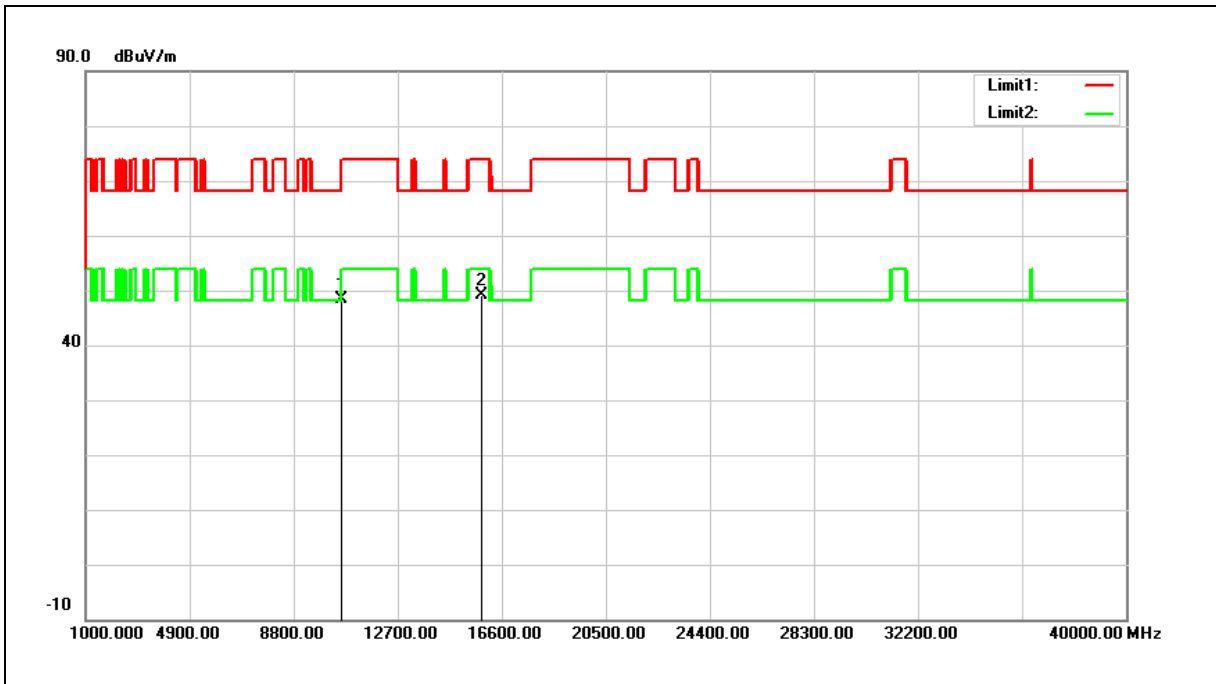

No.	Frequency (MHz)	Reading (dBuV)	Correct Factor (dB/m)	Result (dBuV/m)	Limit (dBuV/m)	Margin (dB)	Remark
1	10580.000	31.12	17.34	48.46	68.20	-19.74	peak
2	15870.000	31.56	17.57	49.13	74.00	-24.87	peak

Note:1.Result (dBuV/m) = Correct Factor (dB/m) + Reading(dBuV).

2.Correction factor (dB/m) = Antenna Factor (dB/m) + Cable loss (dB) – Pre-Amplifier gain (dB).

3.When the peak results are less than average limit, so not need to evaluate the average.

Standard:	FCC Part 15.407	Test Distance:	3 m
Test item:	Harmonic		
Frequency:	5290 MHz		
Mode:	Mode 10		
Ant.Polar.:	Vertical		

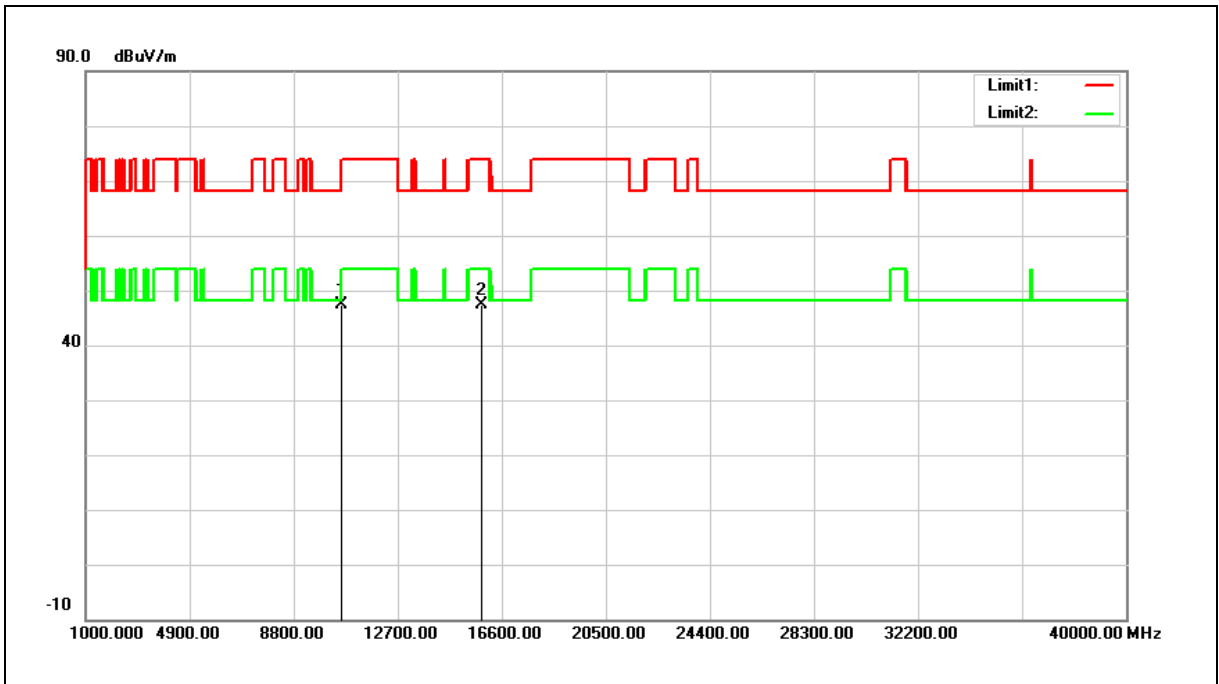

No.	Frequency (MHz)	Reading (dBuV)	Correct Factor (dB/m)	Result (dBuV/m)	Limit (dBuV/m)	Margin (dB)	Remark
1	10580.000	30.11	17.34	47.45	68.20	-20.75	peak
2	15870.000	29.78	17.57	47.35	74.00	-26.65	peak

Note:1.Result (dBuV/m) = Correct Factor (dB/m) + Reading(dBuV).

2.Correction factor (dB/m) = Antenna Factor (dB/m) + Cable loss (dB) – Pre-Amplifier gain (dB).

3.When the peak results are less than average limit, so not need to evaluate the average.

Standard:	FCC Part 15.407	Test Distance:	3 m
Test item:	Harmonic		
Frequency:	5530 MHz		
Mode:	Mode 10		
Ant.Polar.:	Horizontal		

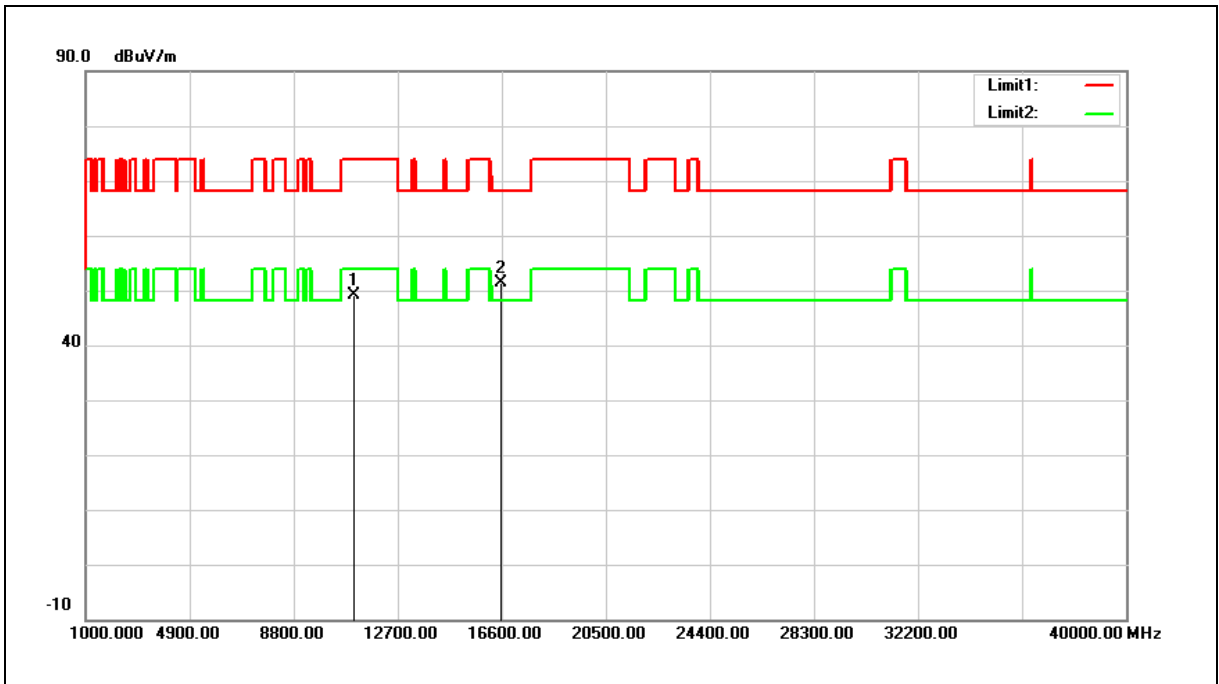

No.	Frequency (MHz)	Reading (dBuV)	Correct Factor (dB/m)	Result (dBuV/m)	Limit (dBuV/m)	Margin (dB)	Remark
1	11060.000	30.71	18.31	49.02	74.00	-24.98	peak
2	16590.000	30.94	20.37	51.31	68.20	-16.89	peak

Note:1.Result (dBuV/m) = Correct Factor (dB/m) + Reading(dBuV).

2.Correction factor (dB/m) = Antenna Factor (dB/m) + Cable loss (dB) – Pre-Amplifier gain (dB).

3.When the peak results are less than average limit, so not need to evaluate the average.

Standard:	FCC Part 15.407	Test Distance:	3 m
Test item:	Harmonic		
Frequency:	5530 MHz		
Mode:	Mode 10		
Ant.Polar.:	Vertical		

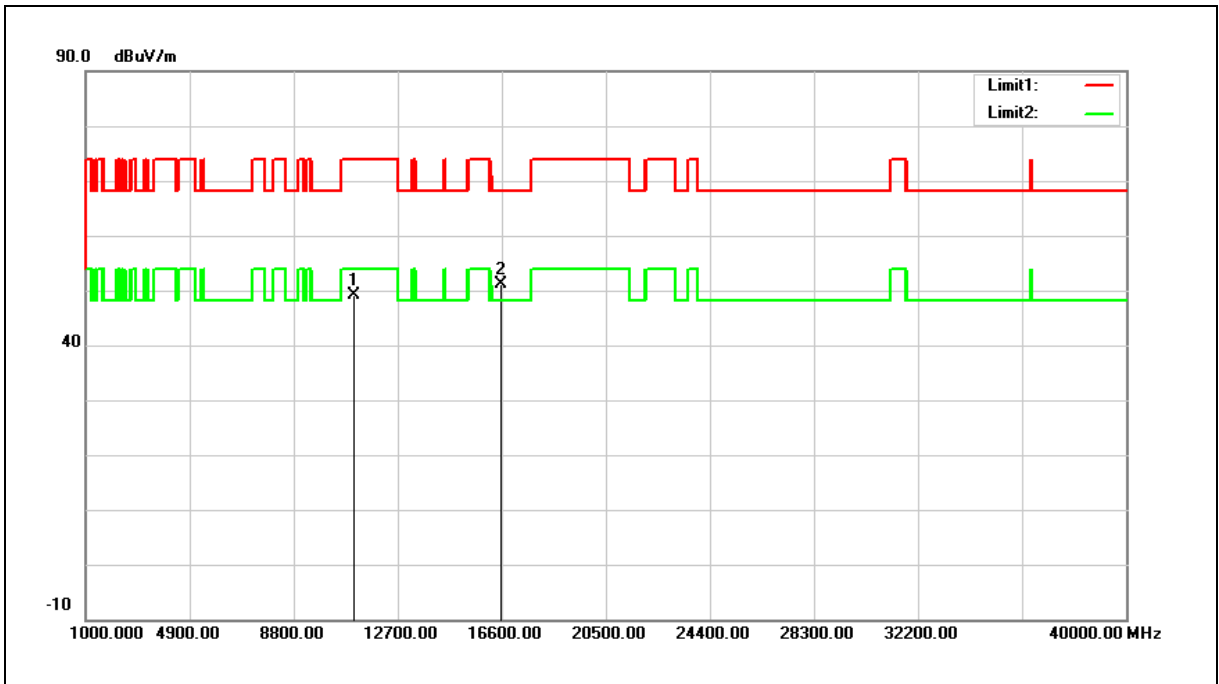

No.	Frequency (MHz)	Reading (dBuV)	Correct Factor (dB/m)	Result (dBuV/m)	Limit (dBuV/m)	Margin (dB)	Remark
1	11060.000	30.92	18.31	49.23	74.00	-24.77	peak
2	16590.000	30.79	20.37	51.16	68.20	-17.04	peak

Note:1.Result (dBuV/m) = Correct Factor (dB/m) + Reading(dBuV).

2.Correction factor (dB/m) = Antenna Factor (dB/m) + Cable loss (dB) – Pre-Amplifier gain (dB).

3.When the peak results are less than average limit, so not need to evaluate the average.

Standard:	FCC Part 15.407	Test Distance:	3 m
Test item:	Harmonic		
Frequency:	5610 MHz		
Mode:	Mode 10		
Ant.Polar.:	Horizontal		

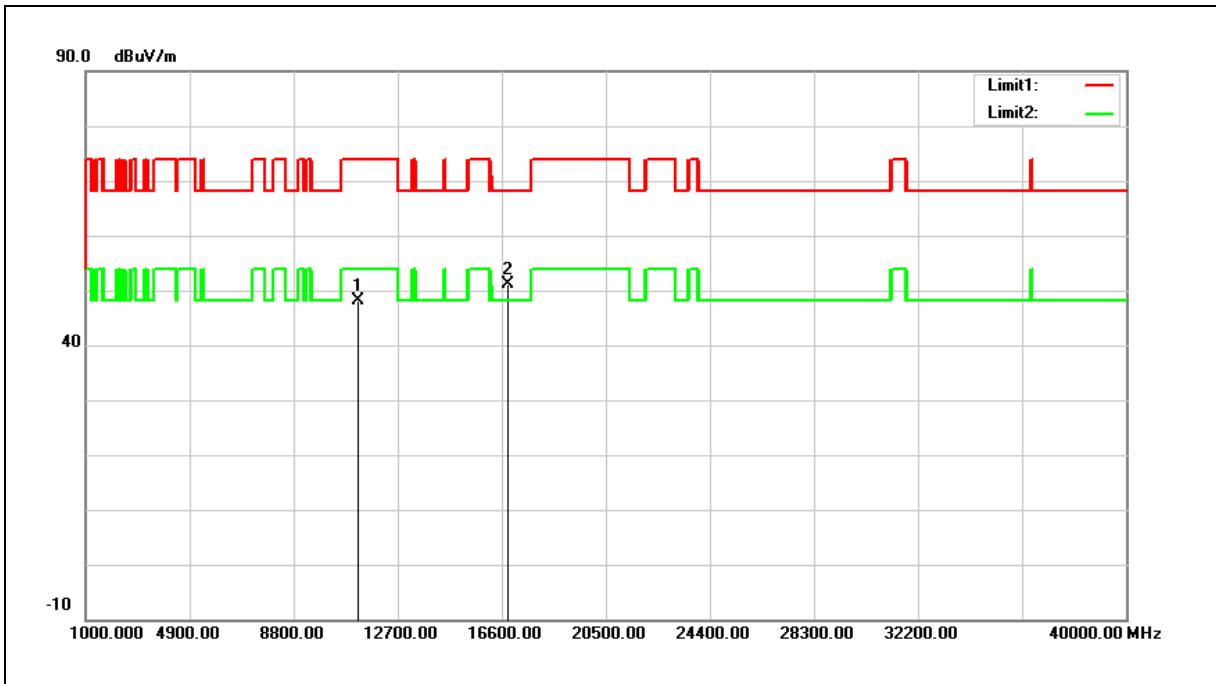

No.	Frequency (MHz)	Reading (dBuV)	Correct Factor (dB/m)	Result (dBuV/m)	Limit (dBuV/m)	Margin (dB)	Remark
1	11220.000	29.63	18.38	48.01	74.00	-25.99	peak
2	16830.000	29.17	21.91	51.08	68.20	-17.12	peak

Note:1.Result (dBuV/m) = Correct Factor (dB/m) + Reading(dBuV).

2.Correction factor (dB/m) = Antenna Factor (dB/m) + Cable loss (dB) – Pre-Amplifier gain (dB).

3.When the peak results are less than average limit, so not need to evaluate the average.

Standard:	FCC Part 15.407	Test Distance:	3 m
Test item:	Harmonic		
Frequency:	5610 MHz		
Mode:	Mode 10		
Ant.Polar.:	Vertical		

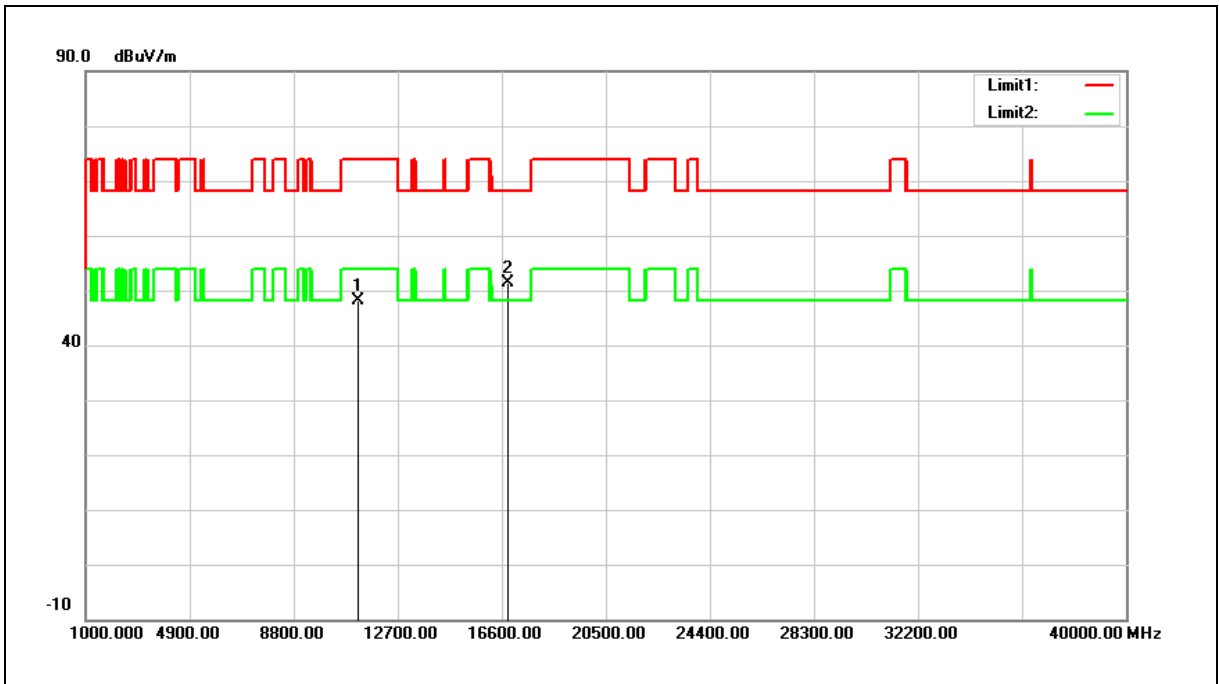

No.	Frequency (MHz)	Reading (dBuV)	Correct Factor (dB/m)	Result (dBuV/m)	Limit (dBuV/m)	Margin (dB)	Remark
1	11220.000	29.69	18.38	48.07	74.00	-25.93	peak
2	16830.000	29.44	21.91	51.35	68.20	-16.85	peak

Note:1.Result (dBuV/m) = Correct Factor (dB/m) + Reading(dBuV).

2.Correction factor (dB/m) = Antenna Factor (dB/m) + Cable loss (dB) – Pre-Amplifier gain (dB).

3.When the peak results are less than average limit, so not need to evaluate the average.

Standard:	FCC Part 15.407	Test Distance:	3 m
Test item:	Harmonic		
Frequency:	5690 MHz		
Mode:	Mode 10		
Ant.Polar.:	Horizontal		

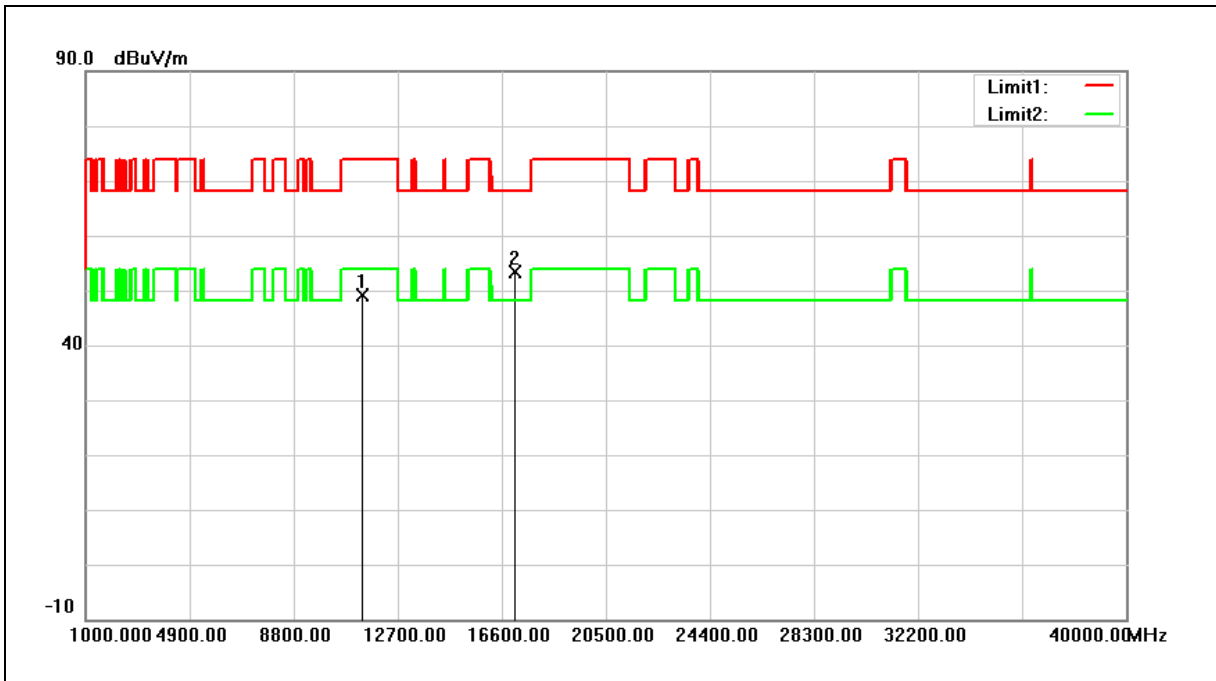

No.	Frequency (MHz)	Reading (dBuV)	Correct Factor (dB/m)	Result (dBuV/m)	Limit (dBuV/m)	Margin (dB)	Remark
1	11380.000	30.66	18.44	49.10	74.00	-24.90	peak
2	17070.000	29.91	23.40	53.31	68.20	-14.89	peak

- Note:1.Result (dBuV/m) = Correct Factor (dB/m) + Reading(dBuV).
- 2.Correction factor (dB/m) = Antenna Factor (dB/m) + Cable loss (dB) – Pre-Amplifier gain (dB).
- 3.When the peak results are less than average limit, so not need to evaluate the average.

Standard:	FCC Part 15.407	Test Distance:	3 m
Test item:	Harmonic		
Frequency:	5690 MHz		
Mode:	Mode 10		
Ant.Polar.:	Vertical		

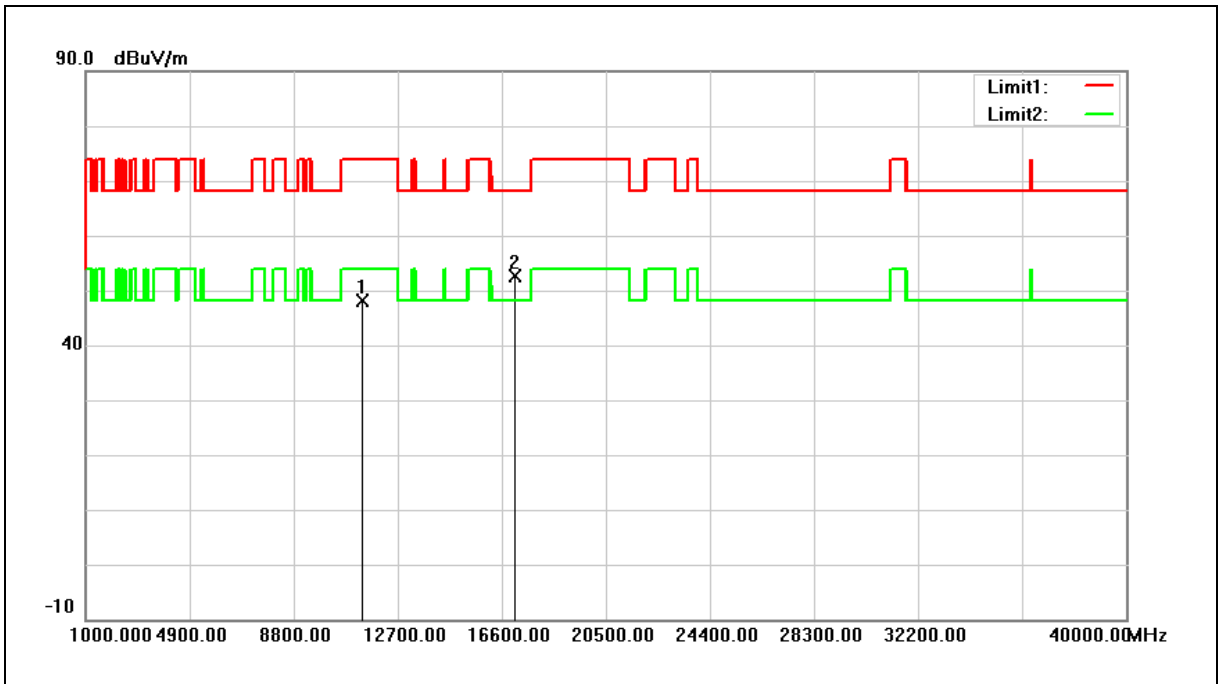

No.	Frequency (MHz)	Reading (dBuV)	Correct Factor (dB/m)	Result (dBuV/m)	Limit (dBuV/m)	Margin (dB)	Remark
1	11380.000	29.76	18.44	48.20	74.00	-25.80	peak
2	17070.000	29.32	23.40	52.72	68.20	-15.48	peak

Note:1.Result (dBuV/m) = Correct Factor (dB/m) + Reading(dBuV).

2.Correction factor (dB/m) = Antenna Factor (dB/m) + Cable loss (dB) – Pre-Amplifier gain (dB).

3.When the peak results are less than average limit, so not need to evaluate the average.

Standard:	FCC Part 15.407	Test Distance:	3 m
Test item:	Transmitter Unwanted Emissions		
Test Mode:	Simultaneous Transmitting (WLAN 2.4 + 5 GHz)		
Ant.Polar.:	Horizontal		

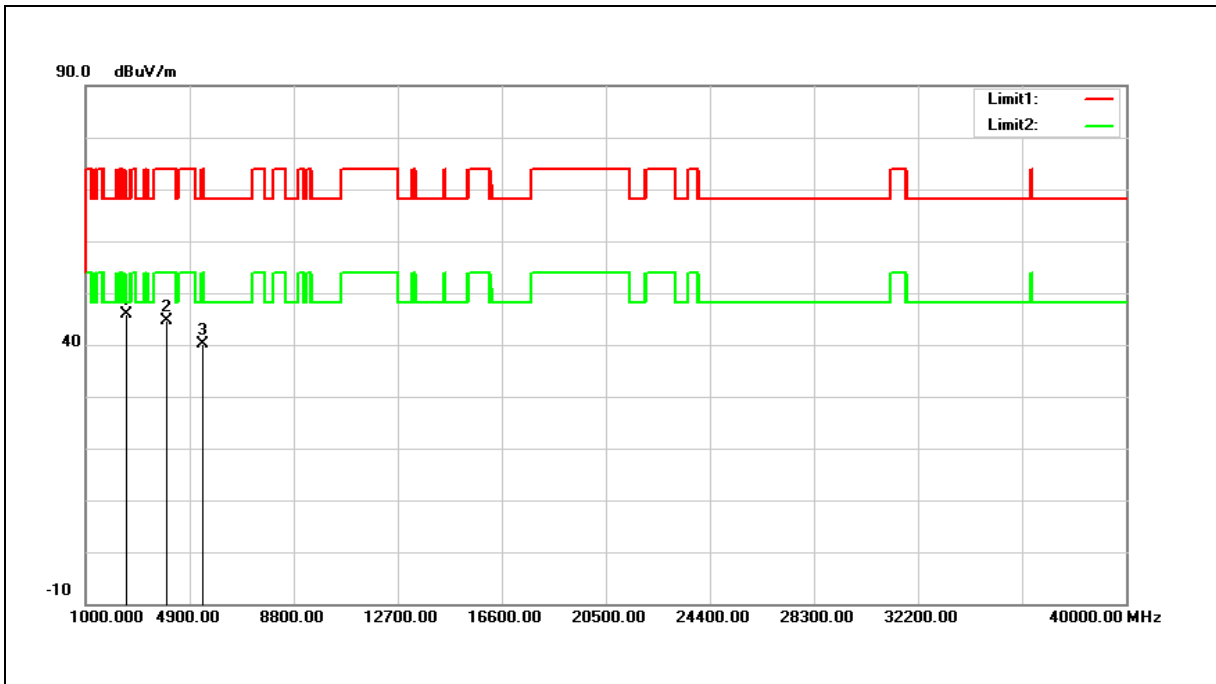

No.	Frequency (MHz)	Reading (dBuV)	Correct Factor (dB/m)	Result (dBuV/m)	Limit (dBuV/m)	Margin (dB)	Remark
1	2496.000	47.76	-1.84	45.92	74.00	-28.08	peak
2	4009.000	41.37	3.16	44.53	74.00	-29.47	peak
3	5403.000	34.03	6.10	40.13	74.00	-33.87	peak

Note:1.Result (dBuV/m) = Correct Factor (dB/m) + Reading(dBuV).

2.Correction factor (dB/m) = Antenna Factor (dB/m) + Cable loss (dB) – Pre-Amplifier gain (dB).

3.When the peak results are less than average limit, so not need to evaluate the average.

Standard:	FCC Part 15.407	Test Distance:	3 m
Test item:	Transmitter Unwanted Emissions		
Test Mode:	Simultaneous Transmitting (WLAN 2.4 + 5 GHz)		
Ant.Polar.:	Vertical		

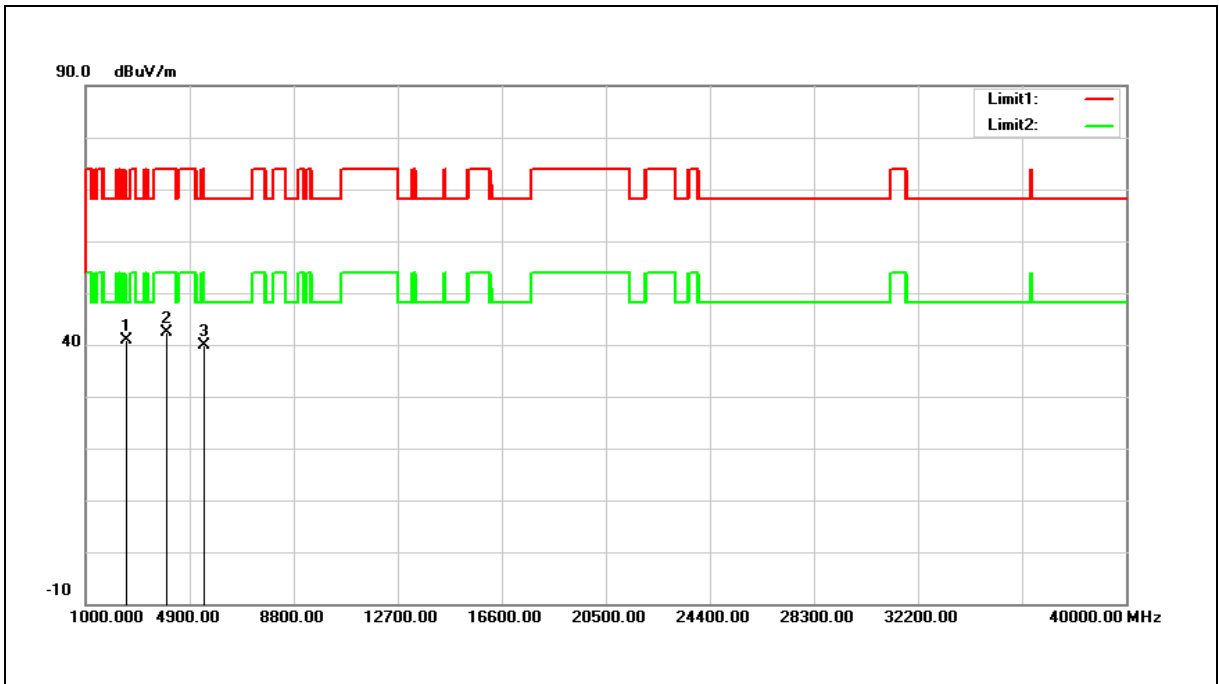

No.	Frequency (MHz)	Reading (dBuV)	Correct Factor (dB/m)	Result (dBuV/m)	Limit (dBuV/m)	Margin (dB)	Remark
1	2496.000	42.65	-1.84	40.81	74.00	-33.19	peak
2	4009.000	39.15	3.16	42.31	74.00	-31.69	peak
3	5420.000	33.83	6.12	39.95	74.00	-34.05	peak

Note:1.Result (dBuV/m) = Correct Factor (dB/m) + Reading(dBuV).

2.Correction factor (dB/m) = Antenna Factor (dB/m) + Cable loss (dB) – Pre-Amplifier gain (dB).

3.When the peak results are less than average limit, so not need to evaluate the average.

Band Edge

Peak

Standard:	FCC Part 15.407	Test Distance:	3 m
Test item:	Band edge		
Frequency:	5260 MHz		
Mode:	Mode 2		
Ant.Polar.:	Horizontal		

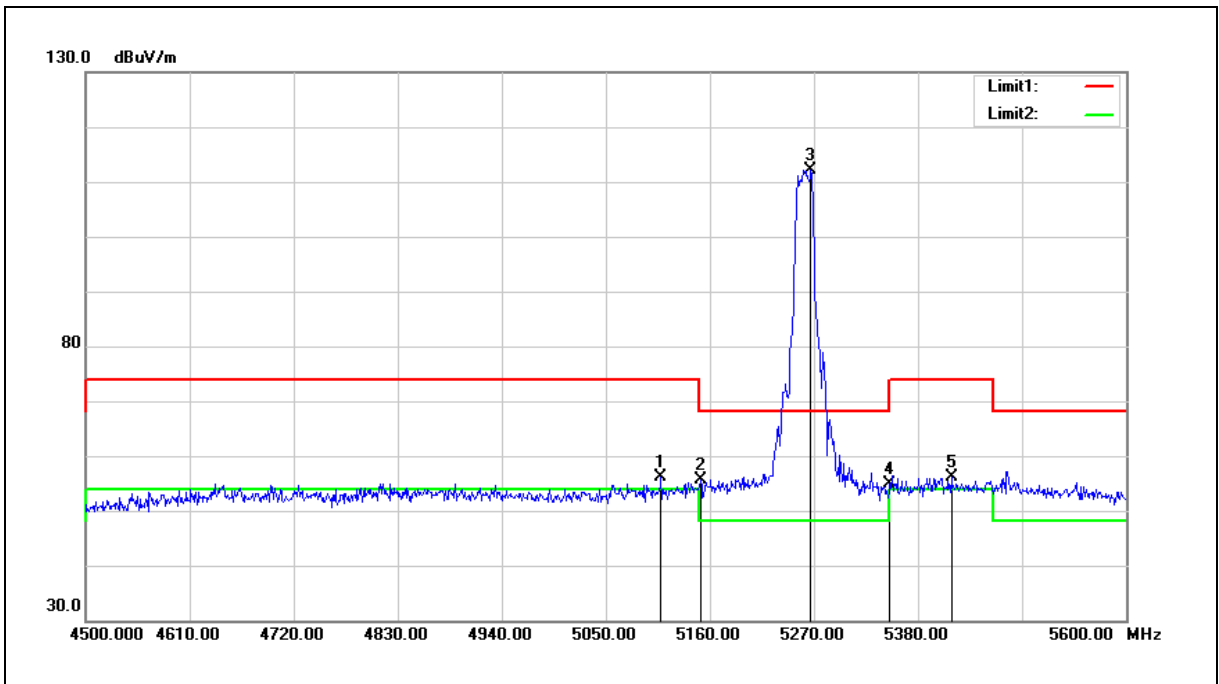

No.	Frequency (MHz)	Reading (dBuV)	Correct Factor (dB/m)	Result (dBuV/m)	Limit (dBuV/m)	Margin (dB)	Remark
1	5108.300	50.33	5.71	56.04	74.00	-17.96	peak
2	5150.000	49.85	5.75	55.60	74.00	-18.40	peak
3	5266.700	106.30	5.89	112.19	68.20	43.99	peak
4	5350.000	48.90	6.00	54.90	74.00	-19.10	peak
5	5415.200	50.04	6.08	56.12	74.00	-17.88	peak

Note:1.Result (dBuV/m) = Correct Factor (dB/m) + Reading(dBuV).

2.Correction factor (dB/m) = Antenna Factor (dB/m) + Cable loss (dB) – Pre-Amplifier gain (dB).

3.When the peak results are less than average limit, so not need to evaluate the average.

Standard:	FCC Part 15.407	Test Distance:	3 m
Test item:	Band edge		
Frequency:	5260 MHz		
Mode:	Mode 2		
Ant.Polar.:	Vertical		

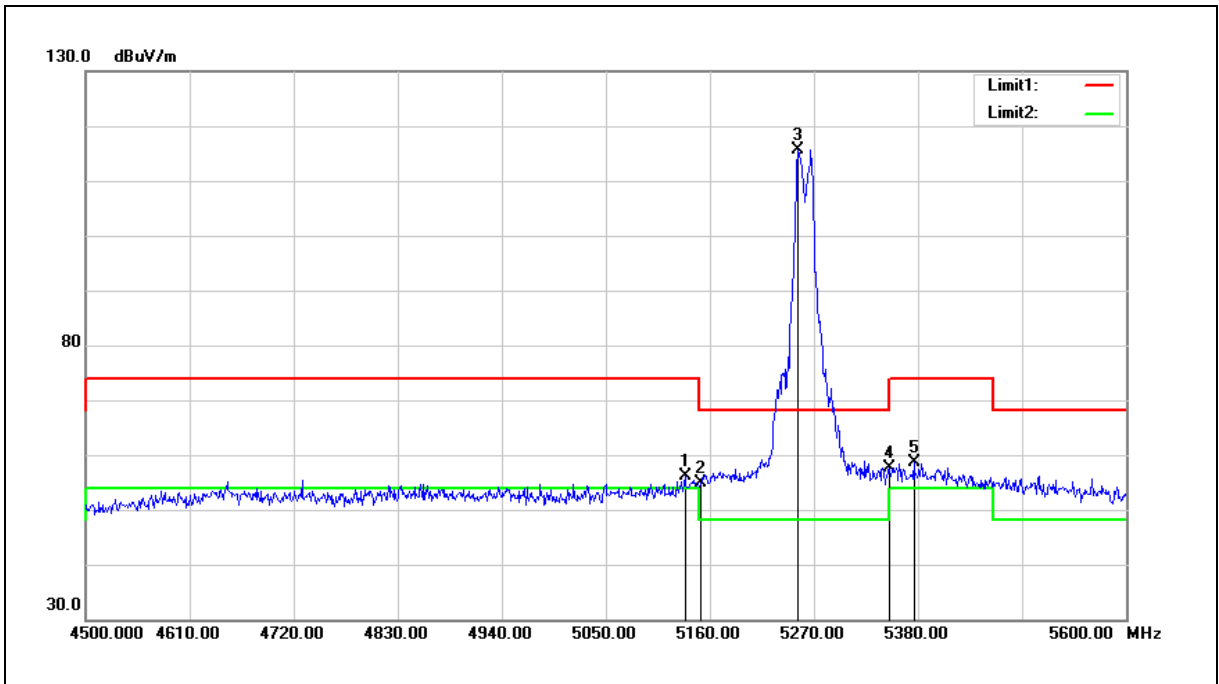

No.	Frequency (MHz)	Reading (dBuV)	Correct Factor (dB/m)	Result (dBuV/m)	Limit (dBuV/m)	Margin (dB)	Remark
1	5133.600	50.41	5.74	56.15	74.00	-17.85	peak
2	5150.000	49.23	5.75	54.98	74.00	-19.02	peak
3	5253.500	109.81	5.88	115.69	68.20	47.49	peak
4	5350.000	51.65	6.00	57.65	74.00	-16.35	peak
5	5375.600	52.50	6.03	58.53	74.00	-15.47	peak

Note:1.Result (dBuV/m) = Correct Factor (dB/m) + Reading(dBuV).

2.Correction factor (dB/m) = Antenna Factor (dB/m) + Cable loss (dB) – Pre-Amplifier gain (dB).

3.When the peak results are less than average limit, so not need to evaluate the average.

Standard:	FCC Part 15.407	Test Distance:	3 m
Test item:	Band edge		
Frequency:	5280 MHz		
Mode:	Mode 2		
Ant.Polar.:	Horizontal		

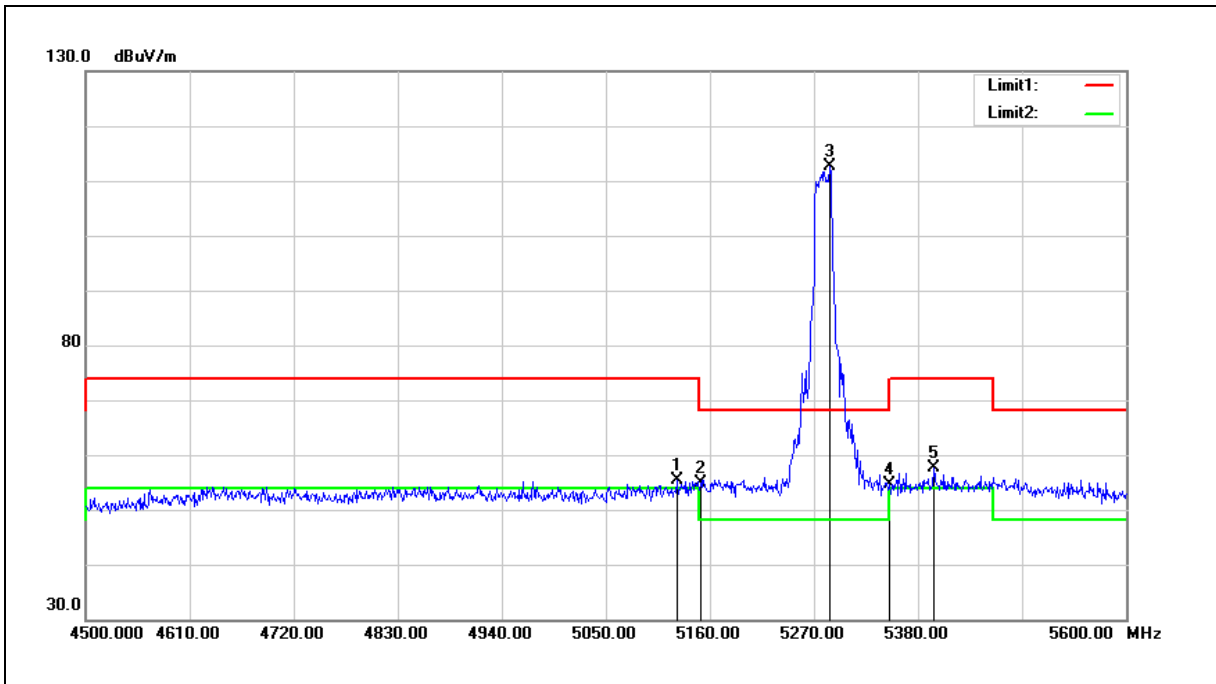

No.	Frequency (MHz)	Reading (dBuV)	Correct Factor (dB/m)	Result (dBuV/m)	Limit (dBuV/m)	Margin (dB)	Remark
1	5124.800	49.61	5.73	55.34	74.00	-18.66	peak
2	5150.000	49.08	5.75	54.83	74.00	-19.17	peak
3	5286.500	106.64	5.92	112.56	68.20	44.36	peak
4	5350.000	48.72	6.00	54.72	74.00	-19.28	peak
5	5396.500	51.65	6.06	57.71	74.00	-16.29	peak

Note:1.Result (dBuV/m) = Correct Factor (dB/m) + Reading(dBuV).

2.Correction factor (dB/m) = Antenna Factor (dB/m) + Cable loss (dB) – Pre-Amplifier gain (dB).

3.When the peak results are less than average limit, so not need to evaluate the average.

Standard:	FCC Part 15.407	Test Distance:	3 m
Test item:	Band edge		
Frequency:	5280 MHz		
Mode:	Mode 2		
Ant.Polar.:	Vertical		

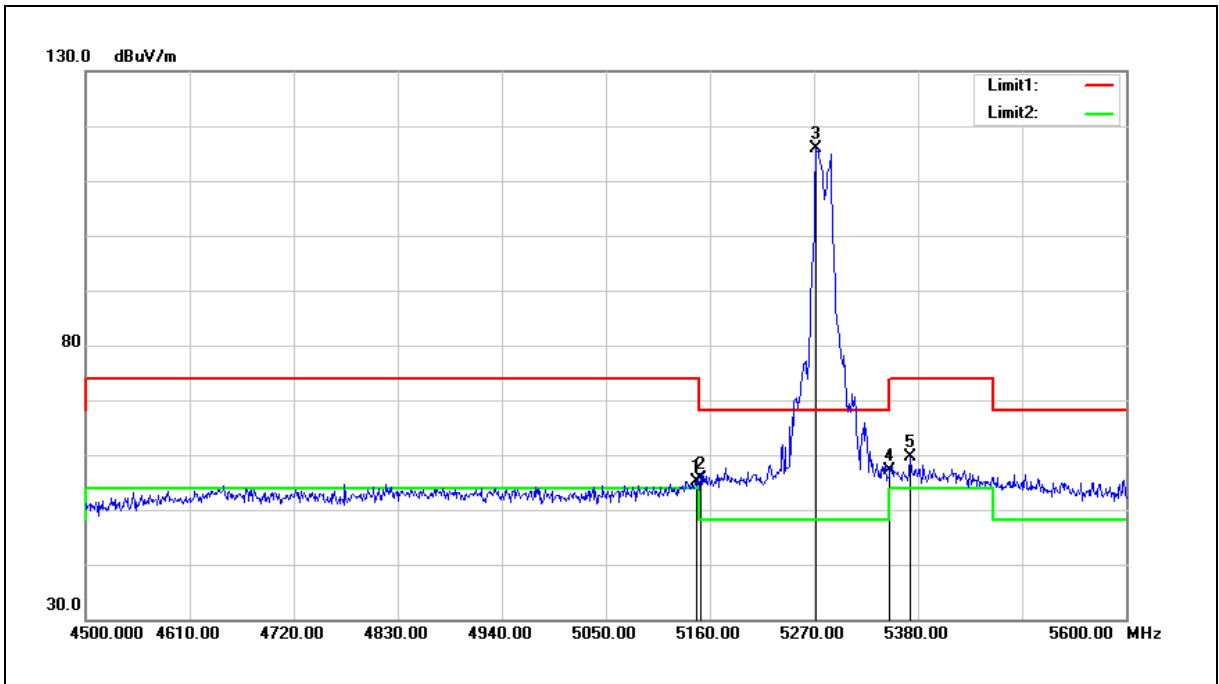

No.	Frequency (MHz)	Reading (dBuV)	Correct Factor (dB/m)	Result (dBuV/m)	Limit (dBuV/m)	Margin (dB)	Remark
1	5145.700	49.37	5.76	55.13	74.00	-18.87	peak
2	5150.000	49.92	5.75	55.67	74.00	-18.33	peak
3	5272.200	109.97	5.91	115.88	68.20	47.68	peak
4	5350.000	51.02	6.00	57.02	74.00	-16.98	peak
5	5371.200	53.56	6.03	59.59	74.00	-14.41	peak

Note:1.Result (dBuV/m) = Correct Factor (dB/m) + Reading(dBuV).

2.Correction factor (dB/m) = Antenna Factor (dB/m) + Cable loss (dB) – Pre-Amplifier gain (dB).

3.When the peak results are less than average limit, so not need to evaluate the average.

Standard:	FCC Part 15.407	Test Distance:	3 m
Test item:	Band edge		
Frequency:	5320 MHz		
Mode:	Mode 2		
Ant.Polar.:	Horizontal		

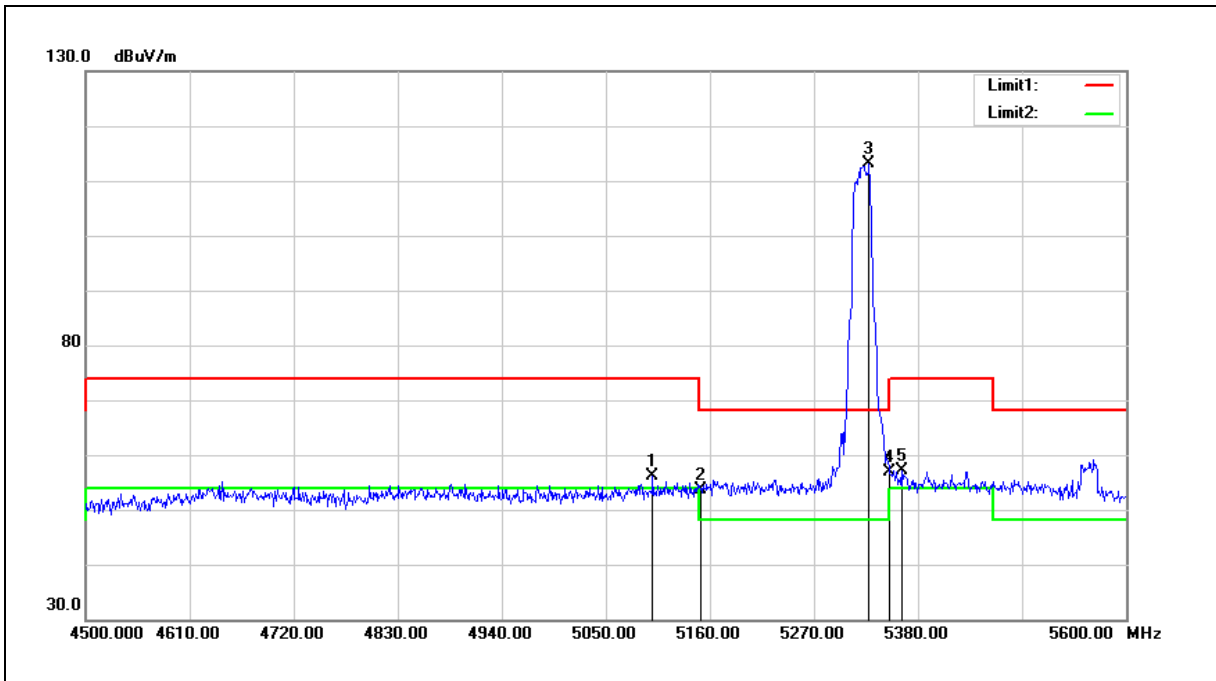

No.	Frequency (MHz)	Reading (dBuV)	Correct Factor (dB/m)	Result (dBuV/m)	Limit (dBuV/m)	Margin (dB)	Remark
1	5099.500	50.41	5.69	56.10	74.00	-17.90	peak
2	5150.000	47.87	5.75	53.62	74.00	-20.38	peak
3	5328.300	107.06	5.98	113.04	68.20	44.84	peak
4	5350.000	50.95	6.00	56.95	74.00	-17.05	peak
5	5362.400	51.07	6.02	57.09	74.00	-16.91	peak

Note:1.Result (dBuV/m) = Correct Factor (dB/m) + Reading(dBuV).

2.Correction factor (dB/m) = Antenna Factor (dB/m) + Cable loss (dB) – Pre-Amplifier gain (dB).

3.When the peak results are less than average limit, so not need to evaluate the average.

Standard:	FCC Part 15.407	Test Distance:	3 m
Test item:	Band edge		
Frequency:	5320 MHz		
Mode:	Mode 2		
Ant.Polar.:	Vertical		

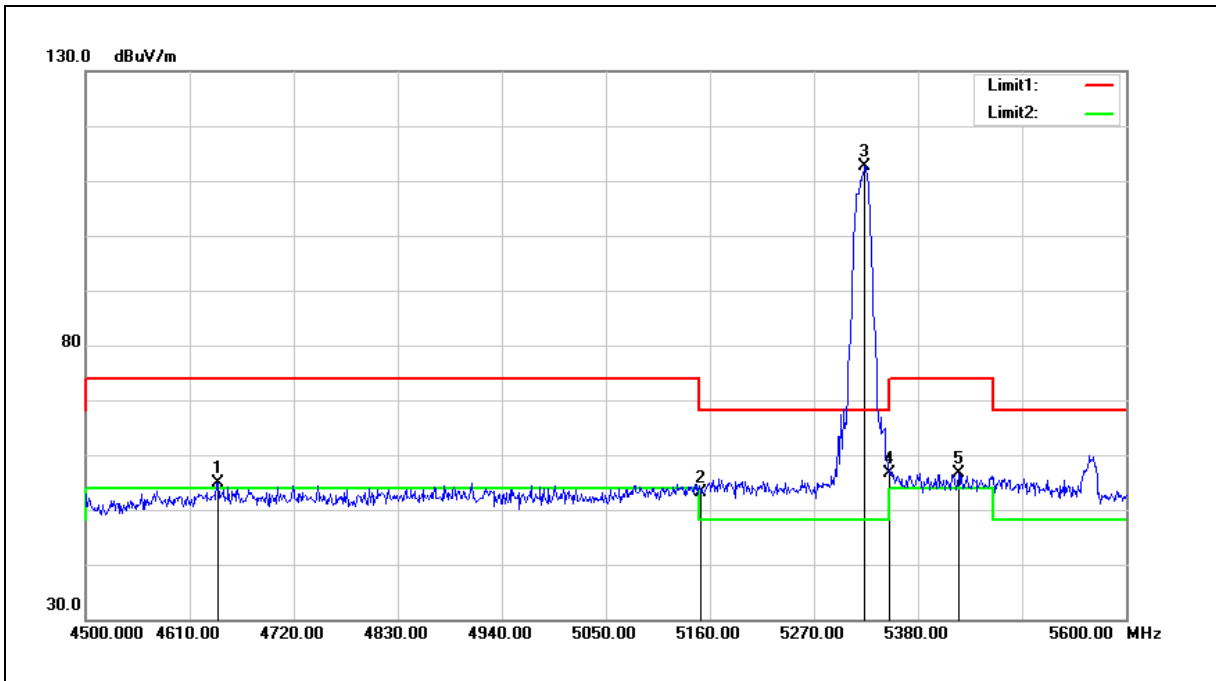

No.	Frequency (MHz)	Reading (dBuV)	Correct Factor (dB/m)	Result (dBuV/m)	Limit (dBuV/m)	Margin (dB)	Remark
1	4639.700	50.41	4.59	55.00	74.00	-19.00	peak
2	5150.000	47.50	5.75	53.25	74.00	-20.75	peak
3	5323.900	106.78	5.97	112.75	68.20	44.55	peak
4	5350.000	50.63	6.00	56.63	74.00	-17.37	peak
5	5422.900	50.64	6.10	56.74	74.00	-17.26	peak

Note:1.Result (dBuV/m) = Correct Factor (dB/m) + Reading(dBuV).

2.Correction factor (dB/m) = Antenna Factor (dB/m) + Cable loss (dB) – Pre-Amplifier gain (dB).

3.When the peak results are less than average limit, so not need to evaluate the average.

Standard:	FCC Part 15.407	Test Distance:	3 m
Test item:	Band edge		
Frequency:	5500 MHz		
Mode:	Mode 2		
Ant.Polar.:	Horizontal		

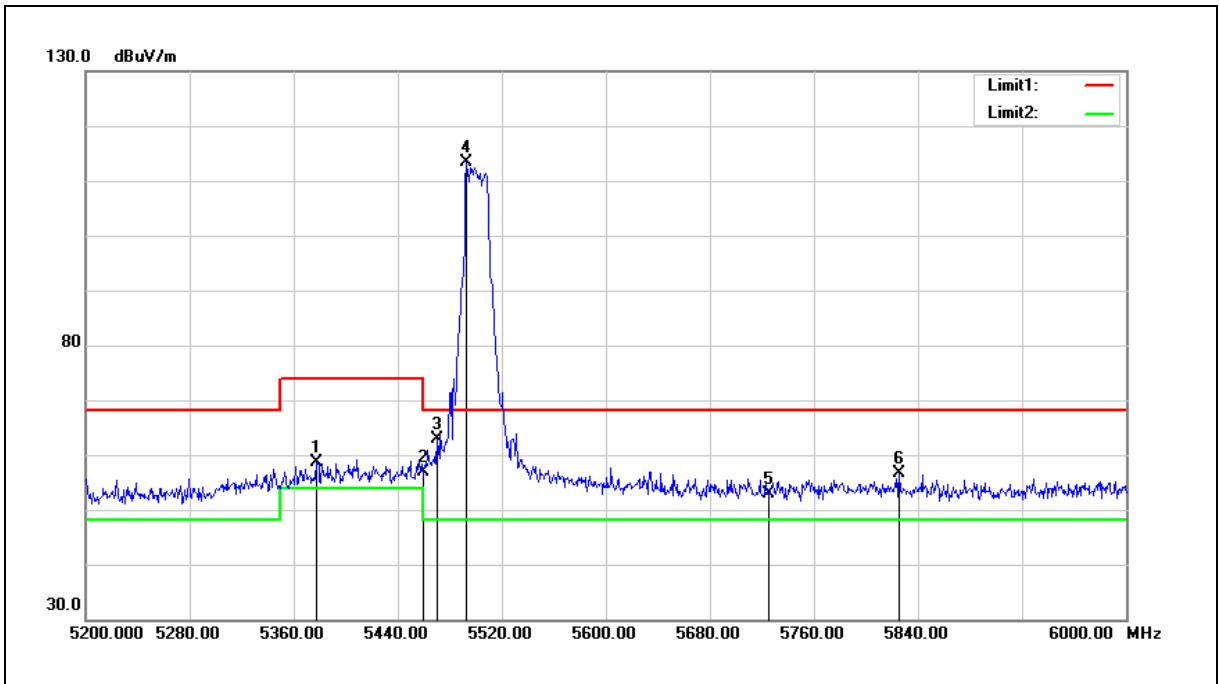

No.	Frequency (MHz)	Reading (dBuV)	Correct Factor (dB/m)	Result (dBuV/m)	Limit (dBuV/m)	Margin (dB)	Remark
1	5377.600	52.55	6.03	58.58	74.00	-15.42	peak
2	5460.000	50.62	6.14	56.76	74.00	-17.24	peak
3	5470.000	56.84	6.15	62.99	68.20	-5.21	peak
4	5492.800	107.10	6.18	113.28	68.20	45.08	peak
5	5725.000	46.05	6.76	52.81	68.20	-15.39	peak
6	5825.600	49.58	7.00	56.58	68.20	-11.62	peak

Note:1.Result (dBuV/m) = Correct Factor (dB/m) + Reading(dBuV).

2.Correction factor (dB/m) = Antenna Factor (dB/m) + Cable loss (dB) – Pre-Amplifier gain (dB).

3.When the peak results are less than average limit, so not need to evaluate the average.

Standard:	FCC Part 15.407	Test Distance:	3 m
Test item:	Band edge		
Frequency:	5500 MHz		
Mode:	Mode 2		
Ant.Polar.:	Vertical		

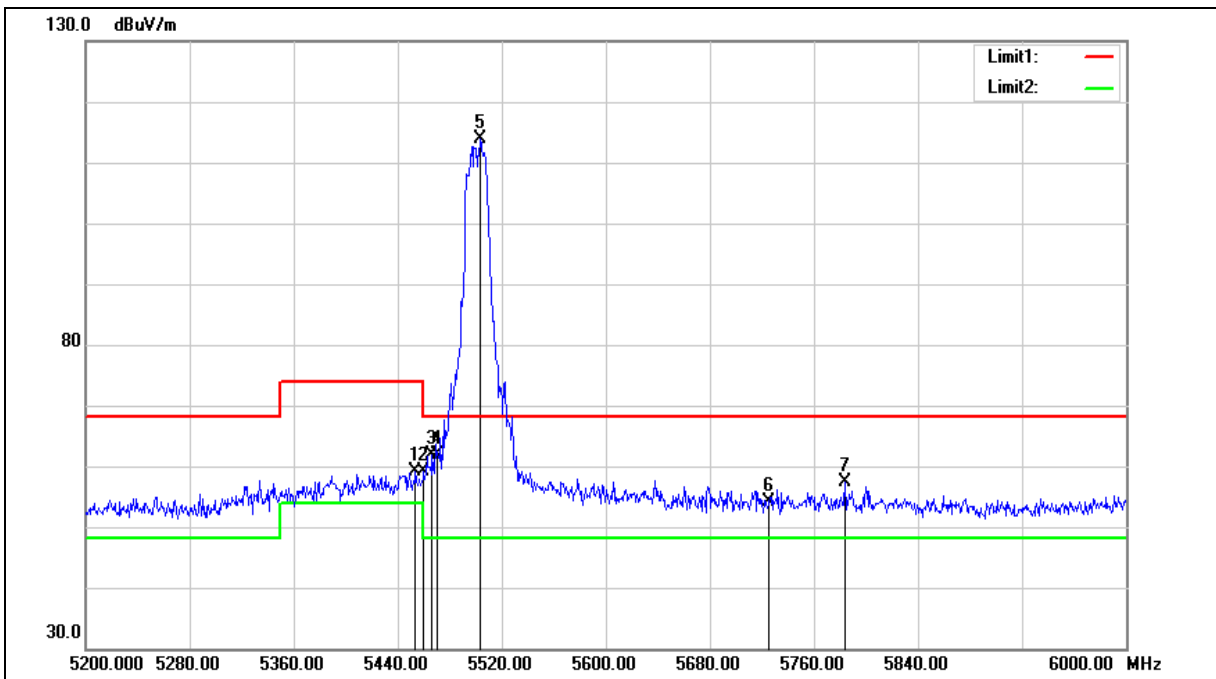

Standard:	FCC Part 15.407	Test Distance:	3 m
Test item:	Band edge		
Frequency:	5500 MHz		
Mode:	Mode 2		
Ant.Polar.:	Vertical		

No.	Frequency (MHz)	Reading (dBuV)	Correct Factor (dB/m)	Result (dBuV/m)	Limit (dBuV/m)	Margin (dB)	Remark
1	5453.600	53.00	6.12	59.12	74.00	-14.88	peak
2	5460.000	53.00	6.14	59.14	74.00	-14.86	peak
3	5466.400	55.85	6.14	61.99	68.20	-6.21	peak
4	5470.000	55.69	6.15	61.84	68.20	-6.36	peak
5	5503.200	107.64	6.19	113.83	68.20	45.63	peak
6	5725.000	47.40	6.76	54.16	68.20	-14.04	peak
7	5784.000	50.52	6.90	57.42	68.20	-10.78	peak

Note:1.Result (dBuV/m) = Correct Factor (dB/m) + Reading(dBuV).

2.Correction factor (dB/m) = Antenna Factor (dB/m) + Cable loss (dB) – Pre-Amplifier gain (dB).

3.When the peak results are less than average limit, so not need to evaluate the average.

Standard:	FCC Part 15.407	Test Distance:	3 m
Test item:	Band edge		
Frequency:	5560 MHz		
Mode:	Mode 2		
Ant.Polar.:	Horizontal		

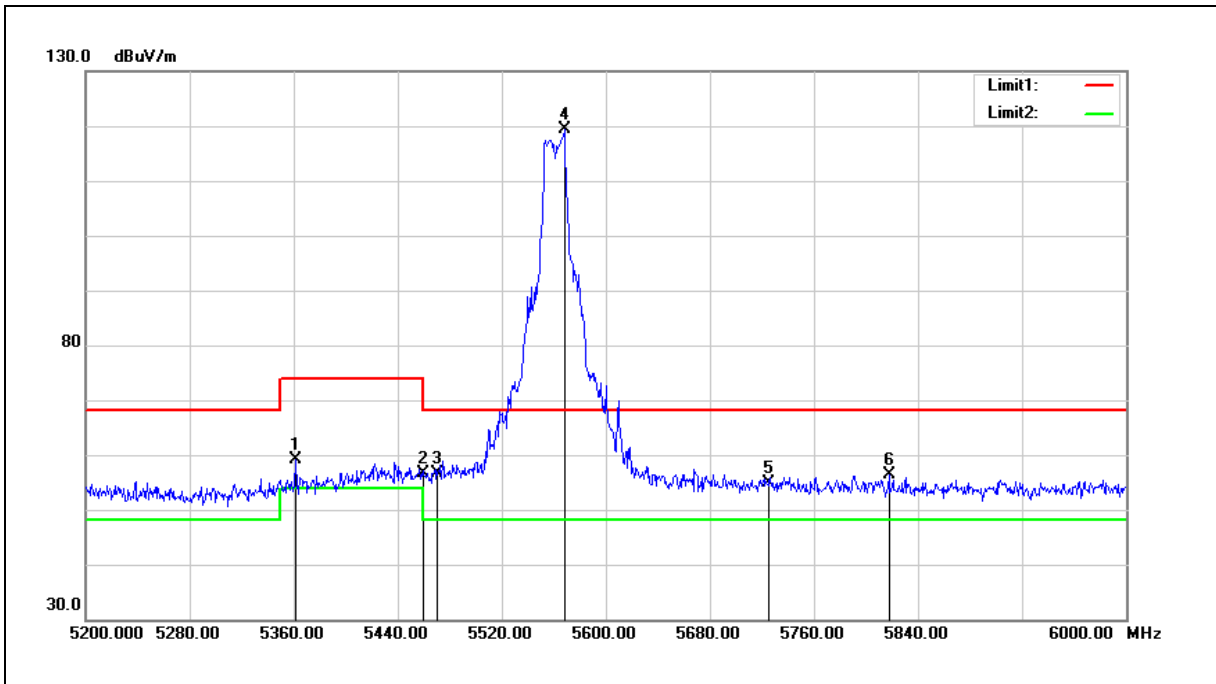

No.	Frequency (MHz)	Reading (dBuV)	Correct Factor (dB/m)	Result (dBuV/m)	Limit (dBuV/m)	Margin (dB)	Remark
1	5361.600	53.09	6.02	59.11	74.00	-14.89	peak
2	5460.000	50.40	6.14	56.54	74.00	-17.46	peak
3	5470.000	50.50	6.15	56.65	68.20	-11.55	peak
4	5568.000	112.96	6.36	119.32	68.20	51.12	peak
5	5725.000	48.05	6.76	54.81	68.20	-13.39	peak
6	5817.600	49.34	6.97	56.31	68.20	-11.89	peak

Note:1.Result (dBuV/m) = Correct Factor (dB/m) + Reading(dBuV).

2.Correction factor (dB/m) = Antenna Factor (dB/m) + Cable loss (dB) – Pre-Amplifier gain (dB).

3.When the peak results are less than average limit, so not need to evaluate the average.

Standard:	FCC Part 15.407	Test Distance:	3 m
Test item:	Band edge		
Frequency:	5560 MHz		
Mode:	Mode 2		
Ant.Polar.:	Vertical		

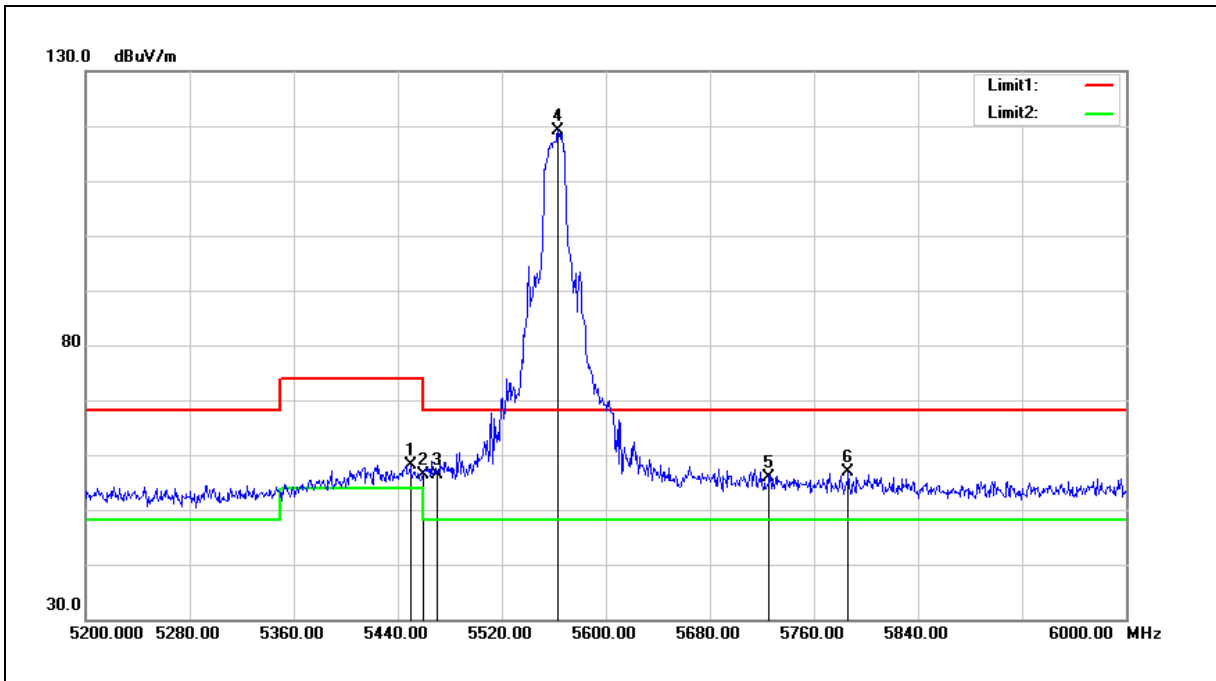

No.	Frequency (MHz)	Reading (dBuV)	Correct Factor (dB/m)	Result (dBuV/m)	Limit (dBuV/m)	Margin (dB)	Remark
1	5449.600	52.08	6.13	58.21	74.00	-15.79	peak
2	5460.000	50.32	6.14	56.46	74.00	-17.54	peak
3	5470.000	50.11	6.15	56.26	68.20	-11.94	peak
4	5563.200	112.91	6.34	119.25	68.20	51.05	peak
5	5725.000	49.21	6.76	55.97	68.20	-12.23	peak
6	5786.400	50.05	6.90	56.95	68.20	-11.25	peak

Note:1.Result (dBuV/m) = Correct Factor (dB/m) + Reading(dBuV).

2.Correction factor (dB/m) = Antenna Factor (dB/m) + Cable loss (dB) – Pre-Amplifier gain (dB).

3.When the peak results are less than average limit, so not need to evaluate the average.

Standard:	FCC Part 15.407	Test Distance:	3 m
Test item:	Band edge		
Frequency:	5700 MHz		
Mode:	Mode 2		
Ant.Polar.:	Horizontal		

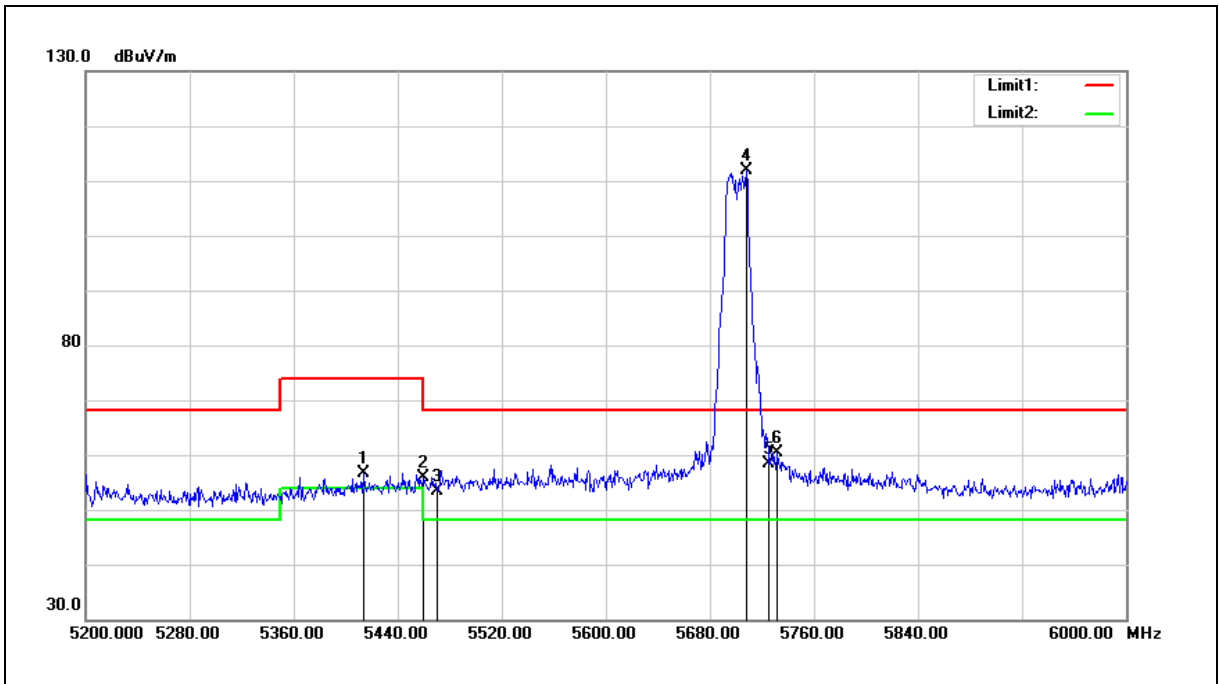

No.	Frequency (MHz)	Reading (dBuV)	Correct Factor (dB/m)	Result (dBuV/m)	Limit (dBuV/m)	Margin (dB)	Remark
1	5413.600	50.53	6.08	56.61	74.00	-17.39	peak
2	5460.000	49.65	6.14	55.79	74.00	-18.21	peak
3	5470.000	47.15	6.15	53.30	68.20	-14.90	peak
4	5708.000	105.29	6.71	112.00	68.20	43.80	peak
5	5725.000	51.50	6.76	58.26	68.20	-9.94	peak
6	5732.000	53.60	6.76	60.36	68.20	-7.84	peak

Note:1.Result (dBuV/m) = Correct Factor (dB/m) + Reading(dBuV).

2.Correction factor (dB/m) = Antenna Factor (dB/m) + Cable loss (dB) – Pre-Amplifier gain (dB).

3.When the peak results are less than average limit, so not need to evaluate the average.

Standard:	FCC Part 15.407	Test Distance:	3 m
Test item:	Band edge		
Frequency:	5700 MHz		
Mode:	Mode 2		
Ant.Polar.:	Vertical		

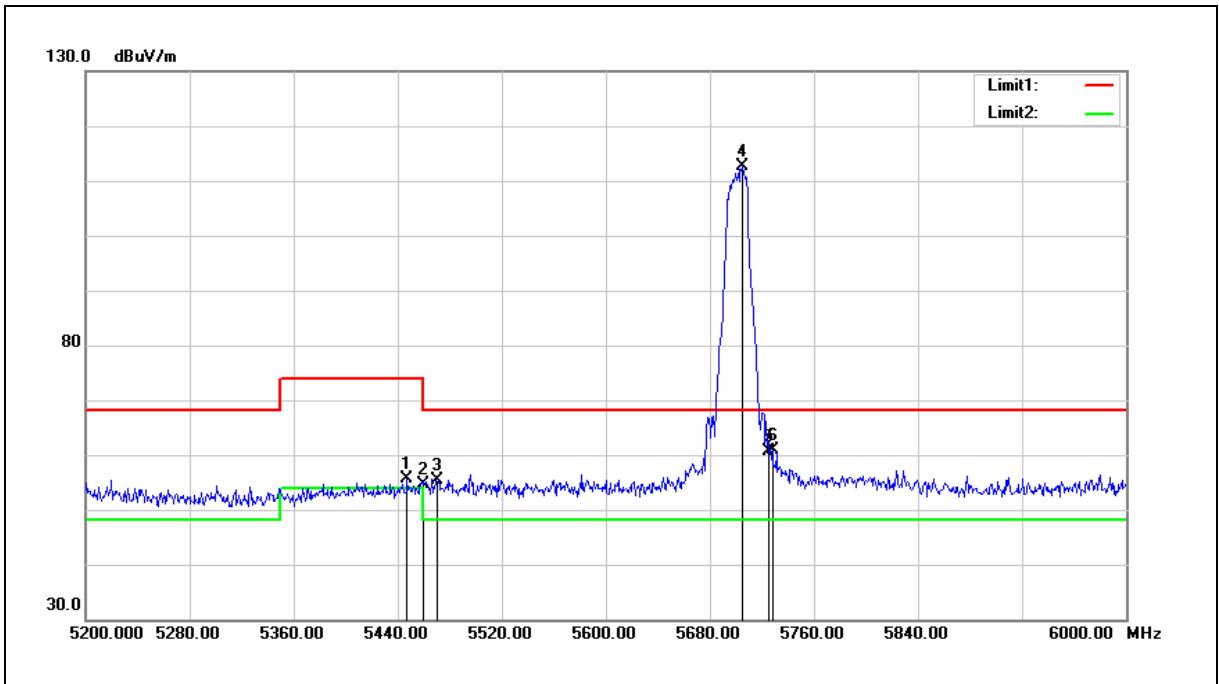

No.	Frequency (MHz)	Reading (dBuV)	Correct Factor (dB/m)	Result (dBuV/m)	Limit (dBuV/m)	Margin (dB)	Remark
1	5447.200	49.44	6.13	55.57	74.00	-18.43	peak
2	5460.000	48.42	6.14	54.56	74.00	-19.44	peak
3	5470.000	49.35	6.15	55.50	68.20	-12.70	peak
4	5704.800	106.03	6.70	112.73	68.20	44.53	peak
5	5725.000	53.95	6.76	60.71	68.20	-7.49	peak
6	5728.000	54.16	6.76	60.92	68.20	-7.28	peak

Note:1.Result (dBuV/m) = Correct Factor (dB/m) + Reading(dBuV).

2.Correction factor (dB/m) = Antenna Factor (dB/m) + Cable loss (dB) – Pre-Amplifier gain (dB).

3.When the peak results are less than average limit, so not need to evaluate the average.

Standard:	FCC Part 15.407	Test Distance:	3 m
Test item:	Band edge		
Frequency:	5720 MHz		
Mode:	Mode 2		
Ant.Polar.:	Horizontal		

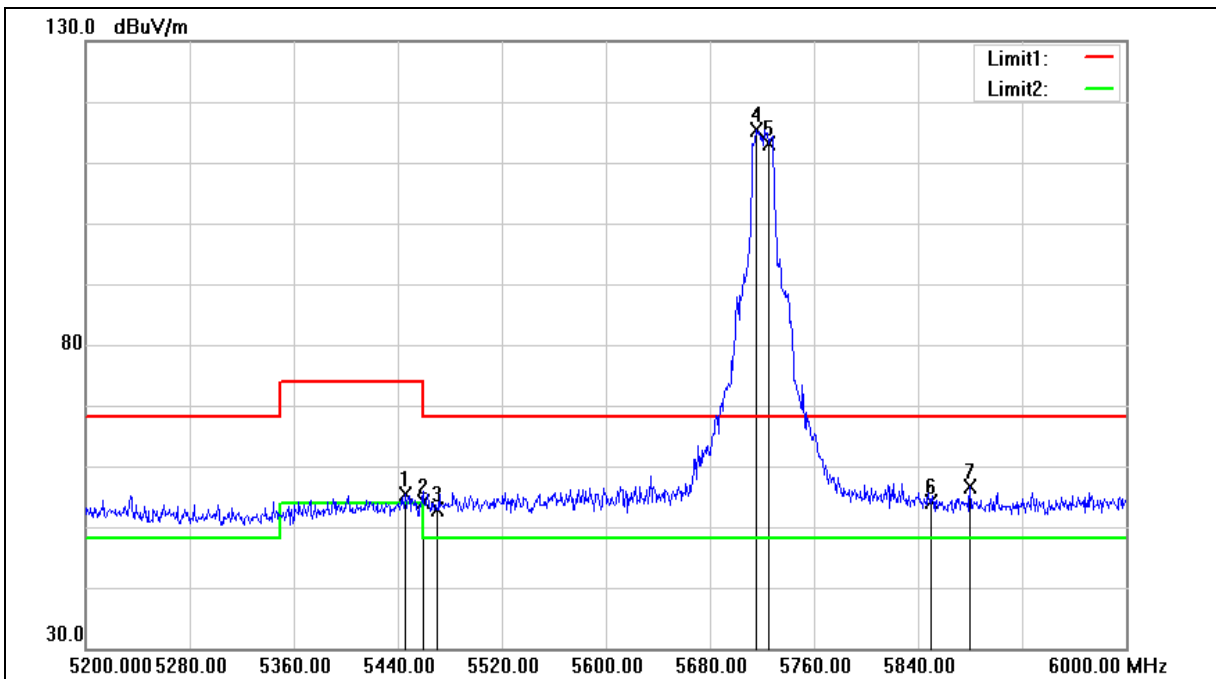

Standard:	FCC Part 15.407	Test Distance:	3 m
Test item:	Band edge		
Frequency:	5720 MHz		
Mode:	Mode 2		
Ant.Polar.:	Horizontal		

No.	Frequency (MHz)	Reading (dBuV)	Correct Factor (dB/m)	Result (dBuV/m)	Limit (dBuV/m)	Margin (dB)	Remark
1	5445.600	49.21	6.13	55.34	74.00	-18.66	peak
2	5460.000	47.97	6.14	54.11	74.00	-19.89	peak
3	5470.000	46.70	6.15	52.85	68.20	-15.35	peak
4	5715.200	108.56	6.72	115.28	68.20	47.08	peak
5	5725.000	106.27	6.76	113.03	68.20	44.83	peak
6	5850.000	46.97	7.05	54.02	68.20	-14.18	peak
7	5880.000	49.38	7.13	56.51	68.20	-11.69	peak

Note:1.Result (dBuV/m) = Correct Factor (dB/m) + Reading(dBuV).

2.Correction factor (dB/m) = Antenna Factor (dB/m) + Cable loss (dB) – Pre-Amplifier gain (dB).

3.When the peak results are less than average limit, so not need to evaluate the average.

Standard:	FCC Part 15.407	Test Distance:	3 m
Test item:	Band edge		
Frequency:	5720 MHz		
Mode:	Mode 2		
Ant.Polar.:	Vertical		

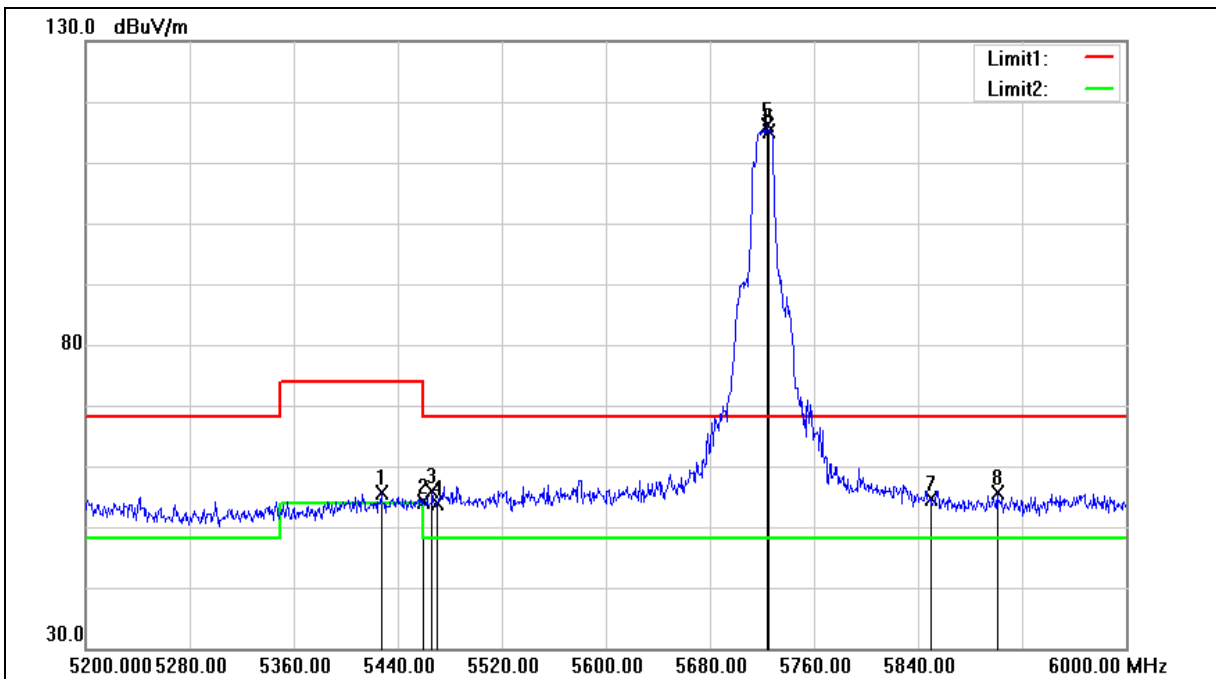

Standard:	FCC Part 15.407	Test Distance:	3 m
Test item:	Band edge		
Frequency:	5720 MHz		
Mode:	Mode 2		
Ant.Polar.:	Vertical		

No.	Frequency (MHz)	Reading (dBuV)	Correct Factor (dB/m)	Result (dBuV/m)	Limit (dBuV/m)	Margin (dB)	Remark
1	5427.200	49.47	6.10	55.57	74.00	-18.43	peak
2	5460.000	48.10	6.14	54.24	74.00	-19.76	peak
3	5466.400	49.72	6.14	55.86	68.20	-12.34	peak
4	5470.000	47.67	6.15	53.82	68.20	-14.38	peak
5	5724.000	109.41	6.74	116.15	68.20	47.95	peak
6	5725.000	108.39	6.76	115.15	68.20	46.95	peak
7	5850.000	47.58	7.05	54.63	68.20	-13.57	peak
8	5900.800	48.36	7.18	55.54	68.20	-12.66	peak

Note:1.Result (dBuV/m) = Correct Factor (dB/m) + Reading(dBuV).

2.Correction factor (dB/m) = Antenna Factor (dB/m) + Cable loss (dB) – Pre-Amplifier gain (dB).

3.When the peak results are less than average limit, so not need to evaluate the average.

Standard:	FCC Part 15.407	Test Distance:	3 m
Test item:	Band edge		
Frequency:	5260 MHz		
Mode:	Mode 8		
Ant.Polar.:	Horizontal		

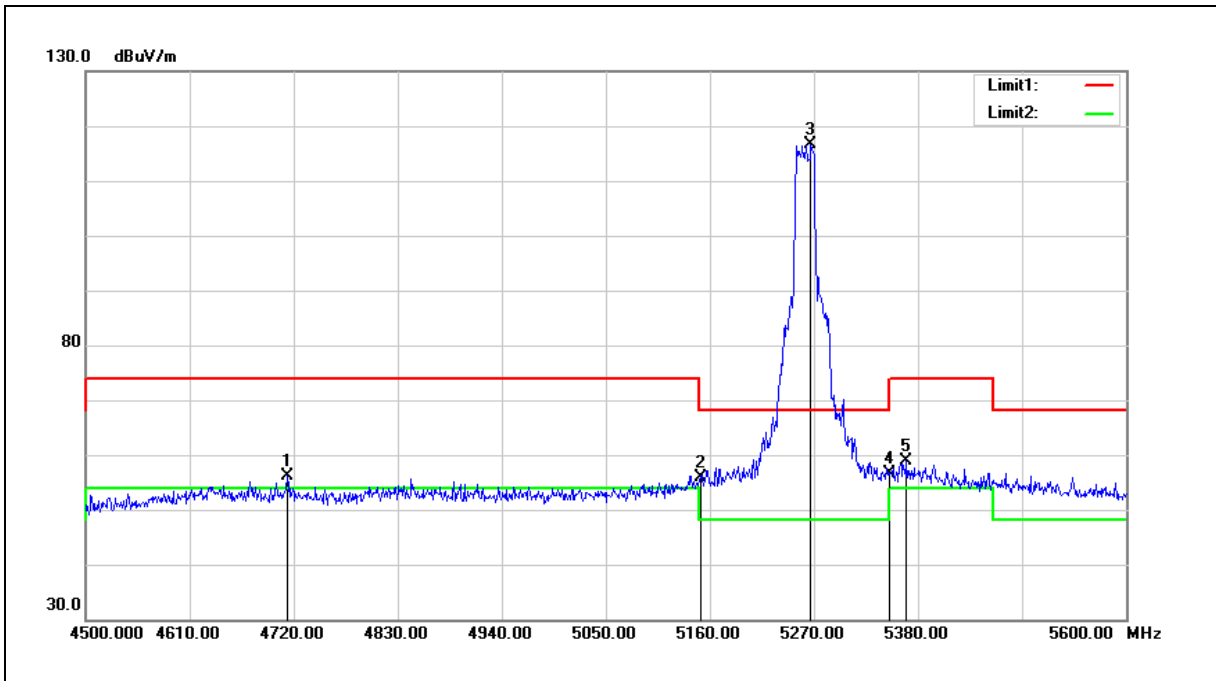

No.	Frequency (MHz)	Reading (dBuV)	Correct Factor (dB/m)	Result (dBuV/m)	Limit (dBuV/m)	Margin (dB)	Remark
1	4713.400	51.28	4.78	56.06	74.00	-17.94	peak
2	5150.000	50.25	5.75	56.00	74.00	-18.00	peak
3	5266.700	110.79	5.89	116.68	68.20	48.48	peak
4	5350.000	50.51	6.00	56.51	74.00	-17.49	peak
5	5367.900	52.96	6.02	58.98	74.00	-15.02	peak

Note:1.Result (dBuV/m) = Correct Factor (dB/m) + Reading(dBuV).

2.Correction factor (dB/m) = Antenna Factor (dB/m) + Cable loss (dB) – Pre-Amplifier gain (dB).

3.When the peak results are less than average limit, so not need to evaluate the average.

Standard:	FCC Part 15.407	Test Distance:	3 m
Test item:	Band edge		
Frequency:	5260 MHz		
Mode:	Mode 8		
Ant.Polar.:	Vertical		

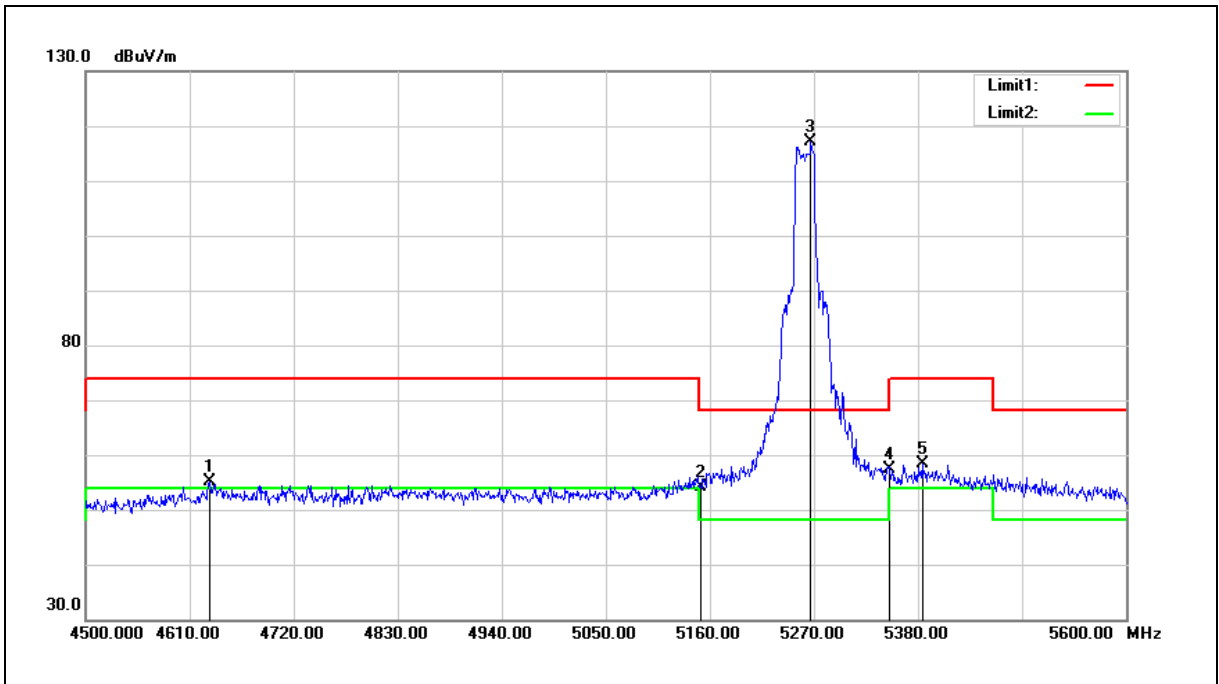

No.	Frequency (MHz)	Reading (dBuV)	Correct Factor (dB/m)	Result (dBuV/m)	Limit (dBuV/m)	Margin (dB)	Remark
1	4630.900	50.44	4.57	55.01	74.00	-18.99	peak
2	5150.000	48.28	5.75	54.03	74.00	-19.97	peak
3	5266.700	111.12	5.89	117.01	68.20	48.81	peak
4	5350.000	51.26	6.00	57.26	74.00	-16.74	peak
5	5384.400	52.32	6.05	58.37	74.00	-15.63	peak

Note:1.Result (dBuV/m) = Correct Factor (dB/m) + Reading(dBuV).

2.Correction factor (dB/m) = Antenna Factor (dB/m) + Cable loss (dB) – Pre-Amplifier gain (dB).

3.When the peak results are less than average limit, so not need to evaluate the average.

Standard:	FCC Part 15.407	Test Distance:	3 m
Test item:	Band edge		
Frequency:	5280 MHz		
Mode:	Mode 8		
Ant.Polar.:	Horizontal		

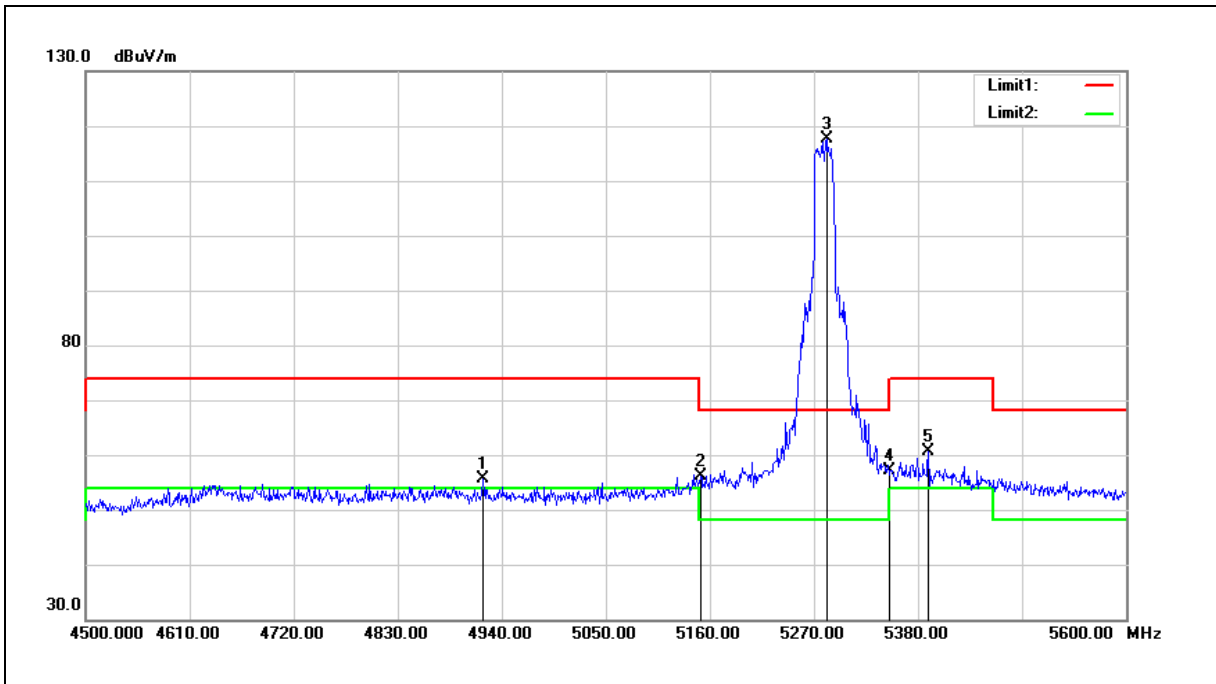

No.	Frequency (MHz)	Reading (dBuV)	Correct Factor (dB/m)	Result (dBuV/m)	Limit (dBuV/m)	Margin (dB)	Remark
1	4920.200	50.34	5.35	55.69	74.00	-18.31	peak
2	5150.000	50.31	5.75	56.06	74.00	-17.94	peak
3	5283.200	111.60	5.92	117.52	68.20	49.32	peak
4	5350.000	51.02	6.00	57.02	74.00	-16.98	peak
5	5391.000	54.59	6.05	60.64	74.00	-13.36	peak

Note:1.Result (dBuV/m) = Correct Factor (dB/m) + Reading(dBuV).

2.Correction factor (dB/m) = Antenna Factor (dB/m) + Cable loss (dB) – Pre-Amplifier gain (dB).

3.When the peak results are less than average limit, so not need to evaluate the average.

Standard:	FCC Part 15.407	Test Distance:	3 m
Test item:	Band edge		
Frequency:	5280 MHz		
Mode:	Mode 8		
Ant.Polar.:	Vertical		

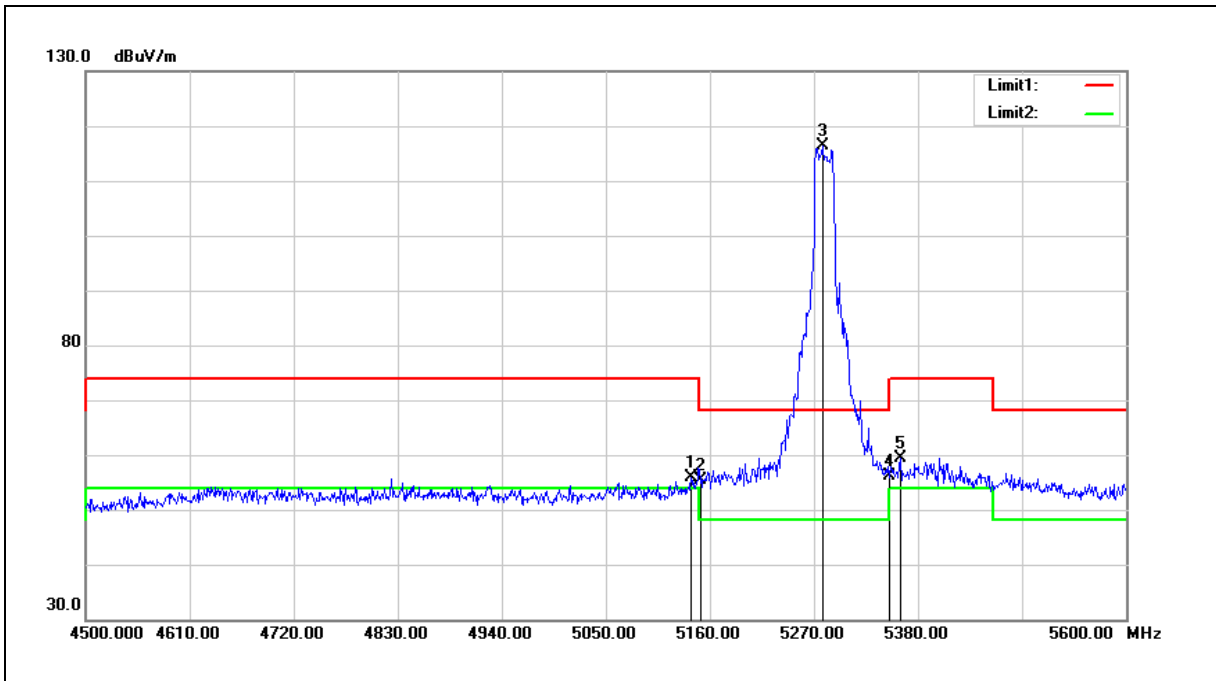

No.	Frequency (MHz)	Reading (dBuV)	Correct Factor (dB/m)	Result (dBuV/m)	Limit (dBuV/m)	Margin (dB)	Remark
1	5140.200	50.25	5.75	56.00	74.00	-18.00	peak
2	5150.000	49.67	5.75	55.42	74.00	-18.58	peak
3	5278.800	110.36	5.91	116.27	68.20	48.07	peak
4	5350.000	50.25	6.00	56.25	74.00	-17.75	peak
5	5361.300	53.44	6.02	59.46	74.00	-14.54	peak

Note:1.Result (dBuV/m) = Correct Factor (dB/m) + Reading(dBuV).

2.Correction factor (dB/m) = Antenna Factor (dB/m) + Cable loss (dB) – Pre-Amplifier gain (dB).

3.When the peak results are less than average limit, so not need to evaluate the average.

Standard:	FCC Part 15.407	Test Distance:	3 m
Test item:	Band edge		
Frequency:	5320 MHz		
Mode:	Mode 8		
Ant.Polar.:	Horizontal		

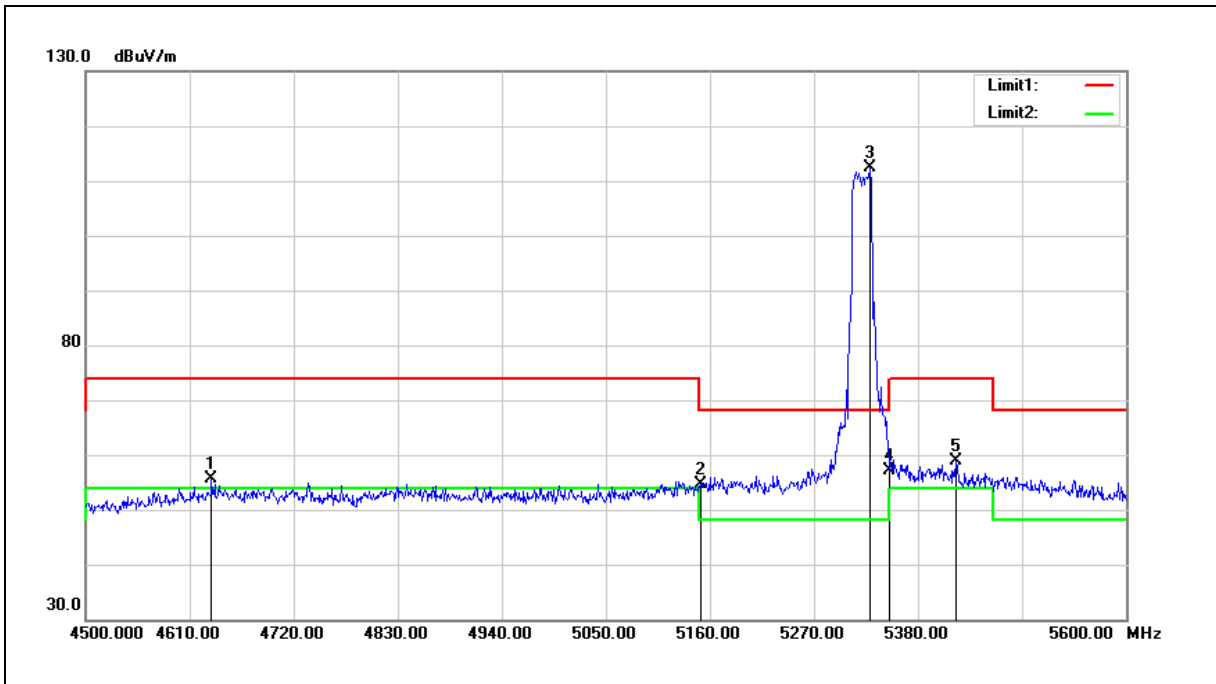

No.	Frequency (MHz)	Reading (dBuV)	Correct Factor (dB/m)	Result (dBuV/m)	Limit (dBuV/m)	Margin (dB)	Remark
1	4633.100	51.03	4.57	55.60	74.00	-18.40	peak
2	5150.000	48.85	5.75	54.60	74.00	-19.40	peak
3	5329.400	106.35	5.98	112.33	68.20	44.13	peak
4	5350.000	51.22	6.00	57.22	74.00	-16.78	peak
5	5420.700	52.70	6.10	58.80	74.00	-15.20	peak

Note:1.Result (dBuV/m) = Correct Factor (dB/m) + Reading(dBuV).

2.Correction factor (dB/m) = Antenna Factor (dB/m) + Cable loss (dB) – Pre-Amplifier gain (dB).

3.When the peak results are less than average limit, so not need to evaluate the average.

Standard:	FCC Part 15.407	Test Distance:	3 m
Test item:	Band edge		
Frequency:	5320 MHz		
Mode:	Mode 8		
Ant.Polar.:	Vertical		

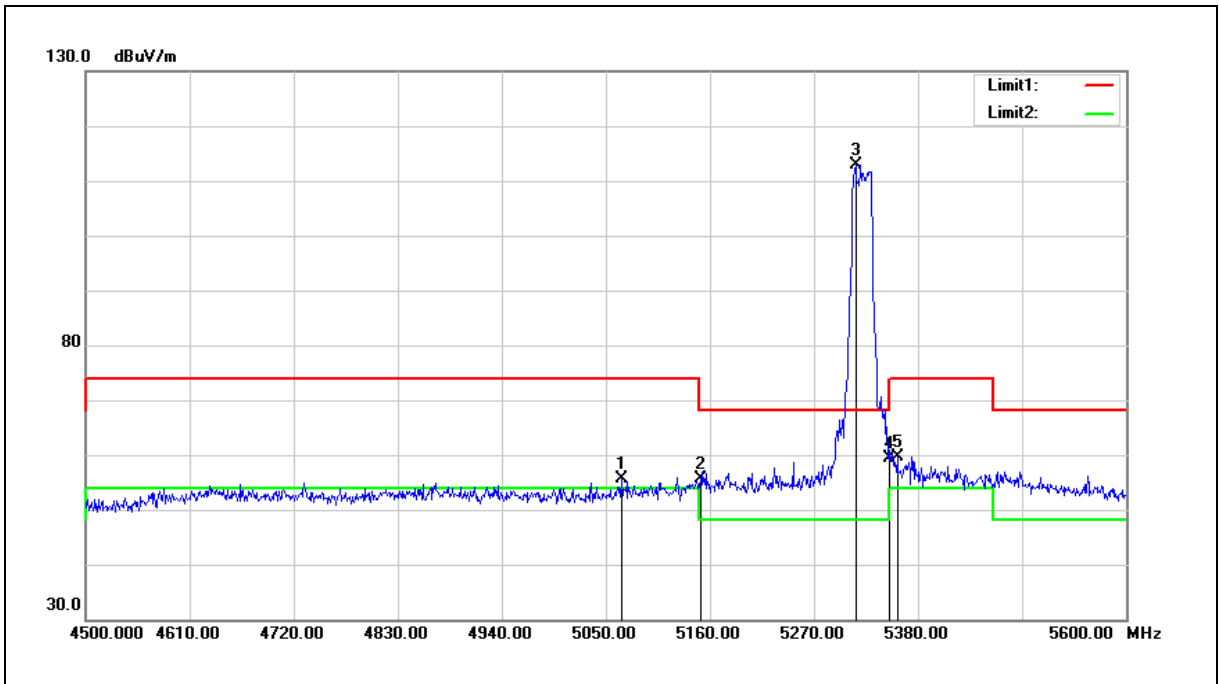

No.	Frequency (MHz)	Reading (dBuV)	Correct Factor (dB/m)	Result (dBuV/m)	Limit (dBuV/m)	Margin (dB)	Remark
1	5066.500	49.88	5.65	55.53	74.00	-18.47	peak
2	5150.000	49.95	5.75	55.70	74.00	-18.30	peak
3	5314.000	106.98	5.96	112.94	68.20	44.74	peak
4	5350.000	53.31	6.00	59.31	74.00	-14.69	peak
5	5358.000	53.69	6.01	59.70	74.00	-14.30	peak

Note:1.Result (dBuV/m) = Correct Factor (dB/m) + Reading(dBuV).

2.Correction factor (dB/m) = Antenna Factor (dB/m) + Cable loss (dB) – Pre-Amplifier gain (dB).

3.When the peak results are less than average limit, so not need to evaluate the average.

Standard:	FCC Part 15.407	Test Distance:	3 m
Test item:	Band edge		
Frequency:	5500 MHz		
Mode:	Mode 8		
Ant.Polar.:	Horizontal		

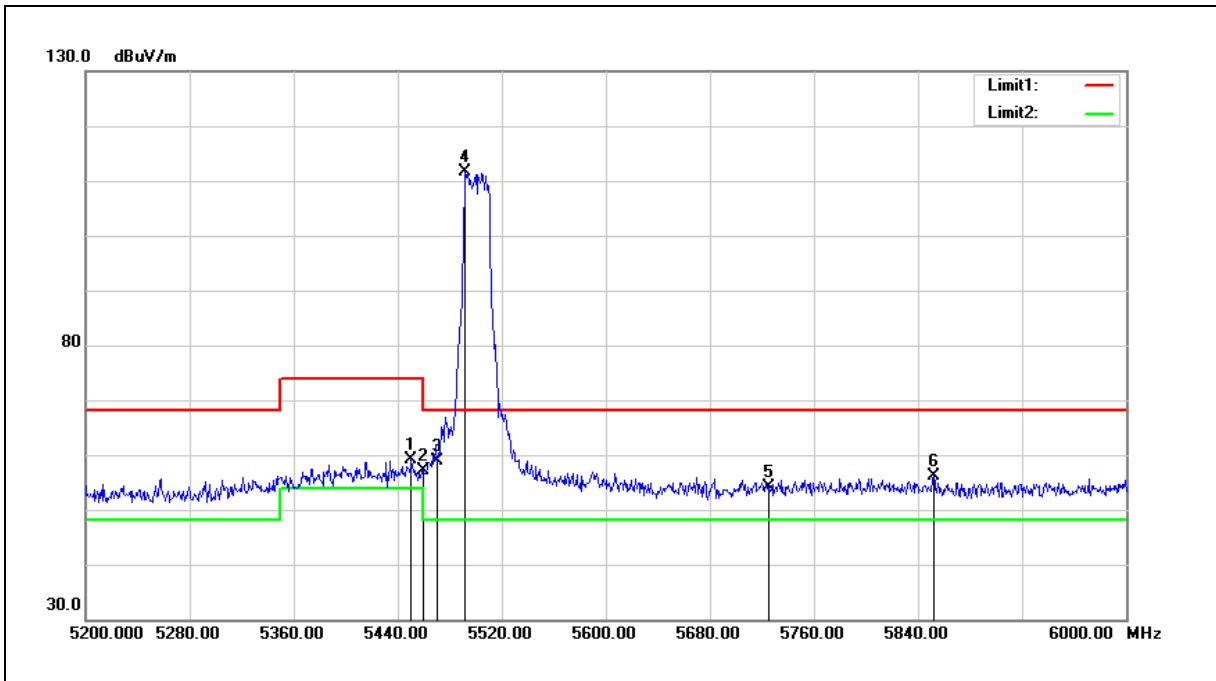

No.	Frequency (MHz)	Reading (dBuV)	Correct Factor (dB/m)	Result (dBuV/m)	Limit (dBuV/m)	Margin (dB)	Remark
1	5450.400	52.99	6.12	59.11	74.00	-14.89	peak
2	5460.000	50.92	6.14	57.06	74.00	-16.94	peak
3	5470.000	52.76	6.15	58.91	68.20	-9.29	peak
4	5492.000	105.53	6.18	111.71	68.20	43.51	peak
5	5725.000	47.41	6.76	54.17	68.20	-14.03	peak
6	5852.000	49.07	7.06	56.13	68.20	-12.07	peak

Note:1.Result (dBuV/m) = Correct Factor (dB/m) + Reading(dBuV).

2.Correction factor (dB/m) = Antenna Factor (dB/m) + Cable loss (dB) – Pre-Amplifier gain (dB).

3.When the peak results are less than average limit, so not need to evaluate the average.

Standard:	FCC Part 15.407	Test Distance:	3 m
Test item:	Band edge		
Frequency:	5500 MHz		
Mode:	Mode 8		
Ant.Polar.:	Vertical		

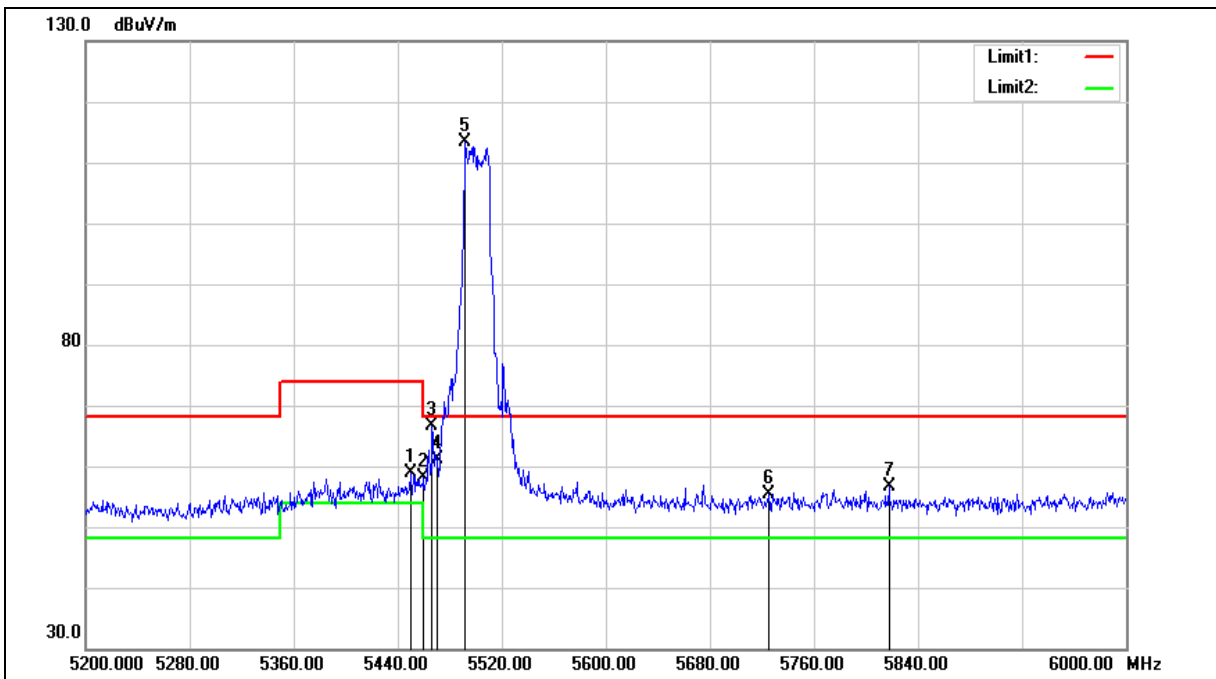

Standard:	FCC Part 15.407	Test Distance:	3 m
Test item:	Band edge		
Frequency:	5500 MHz		
Mode:	Mode 8		
Ant.Polar.:	Vertical		

No.	Frequency (MHz)	Reading (dBuV)	Correct Factor (dB/m)	Result (dBuV/m)	Limit (dBuV/m)	Margin (dB)	Remark
1	5450.400	52.70	6.12	58.82	74.00	-15.18	peak
2	5460.000	52.06	6.14	58.20	74.00	-15.80	peak
3	5466.400	60.38	6.14	66.52	68.20	-1.68	peak
4	5470.000	54.96	6.15	61.11	68.20	-7.09	peak
5	5492.000	107.19	6.18	113.37	68.20	45.17	peak
6	5725.000	48.64	6.76	55.40	68.20	-12.80	peak
7	5817.600	49.71	6.97	56.68	68.20	-11.52	peak

Note:1.Result (dBuV/m) = Correct Factor (dB/m) + Reading(dBuV).

2.Correction factor (dB/m) = Antenna Factor (dB/m) + Cable loss (dB) – Pre-Amplifier gain (dB).

3.When the peak results are less than average limit, so not need to evaluate the average.

Standard:	FCC Part 15.407	Test Distance:	3 m
Test item:	Band edge		
Frequency:	5560 MHz		
Mode:	Mode 8		
Ant.Polar.:	Horizontal		

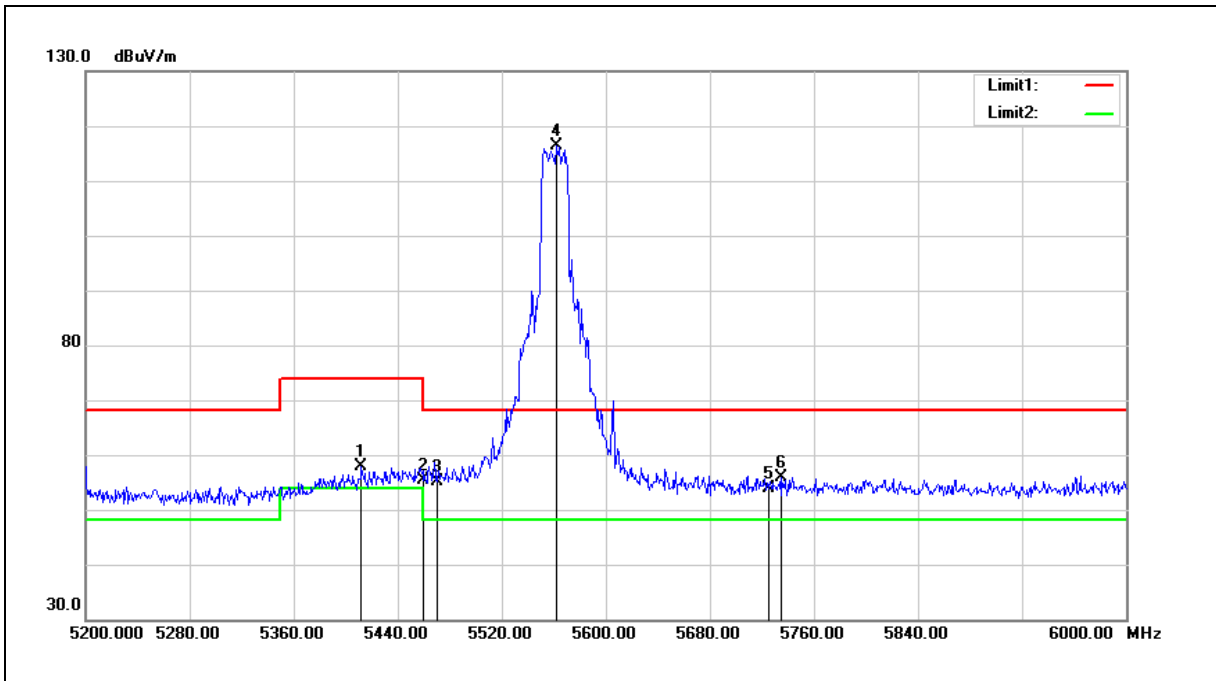

No.	Frequency (MHz)	Reading (dBuV)	Correct Factor (dB/m)	Result (dBuV/m)	Limit (dBuV/m)	Margin (dB)	Remark
1	5412.000	51.76	6.08	57.84	74.00	-16.16	peak
2	5460.000	49.29	6.14	55.43	74.00	-18.57	peak
3	5470.000	49.02	6.15	55.17	68.20	-13.03	peak
4	5561.600	110.09	6.34	116.43	68.20	48.23	peak
5	5725.000	47.14	6.76	53.90	68.20	-14.30	peak
6	5735.200	49.16	6.78	55.94	68.20	-12.26	peak

Note:1.Result (dBuV/m) = Correct Factor (dB/m) + Reading(dBuV).

2.Correction factor (dB/m) = Antenna Factor (dB/m) + Cable loss (dB) – Pre-Amplifier gain (dB).

3.When the peak results are less than average limit, so not need to evaluate the average.

Standard:	FCC Part 15.407	Test Distance:	3 m
Test item:	Band edge		
Frequency:	5560 MHz		
Mode:	Mode 8		
Ant.Polar.:	Vertical		

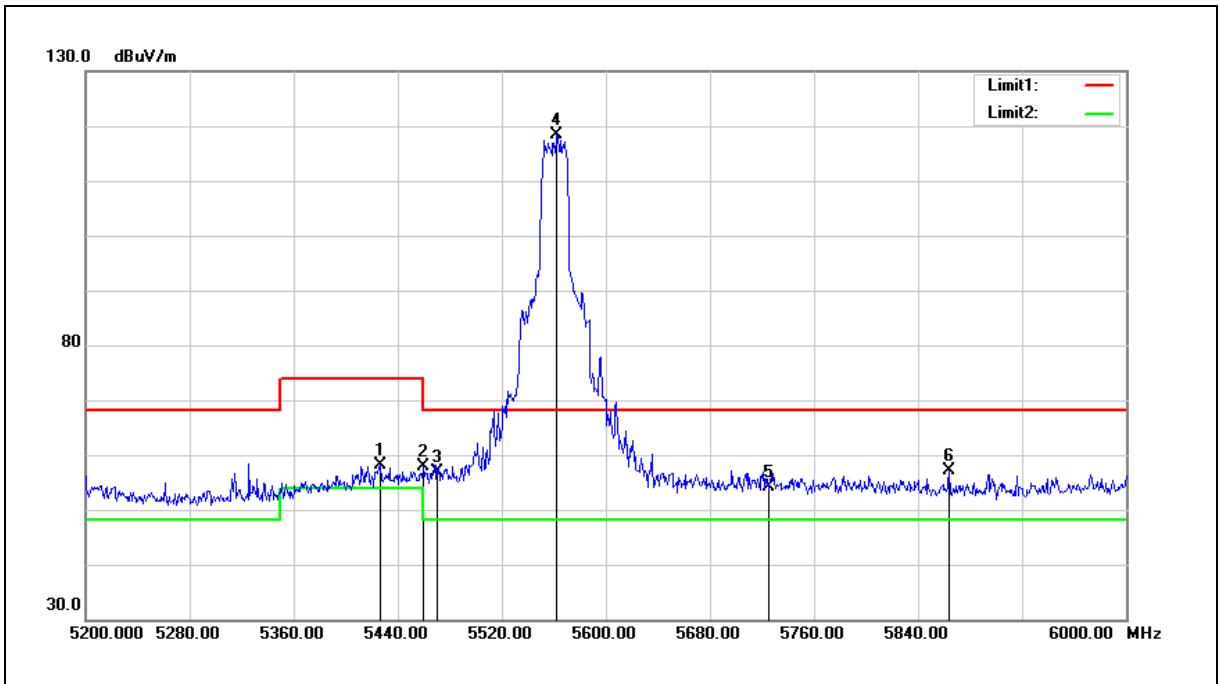

No.	Frequency (MHz)	Reading (dBuV)	Correct Factor (dB/m)	Result (dBuV/m)	Limit (dBuV/m)	Margin (dB)	Remark
1	5426.400	52.11	6.10	58.21	74.00	-15.79	peak
2	5460.000	51.64	6.14	57.78	74.00	-16.22	peak
3	5470.000	50.69	6.15	56.84	68.20	-11.36	peak
4	5562.400	112.11	6.34	118.45	68.20	50.25	peak
5	5725.000	47.46	6.76	54.22	68.20	-13.98	peak
6	5864.000	50.15	7.09	57.24	68.20	-10.96	peak

Note:1.Result (dBuV/m) = Correct Factor (dB/m) + Reading(dBuV).

2.Correction factor (dB/m) = Antenna Factor (dB/m) + Cable loss (dB) – Pre-Amplifier gain (dB).

3.When the peak results are less than average limit, so not need to evaluate the average.

Standard:	FCC Part 15.407	Test Distance:	3 m
Test item:	Band edge		
Frequency:	5700 MHz		
Mode:	Mode 8		
Ant.Polar.:	Horizontal		

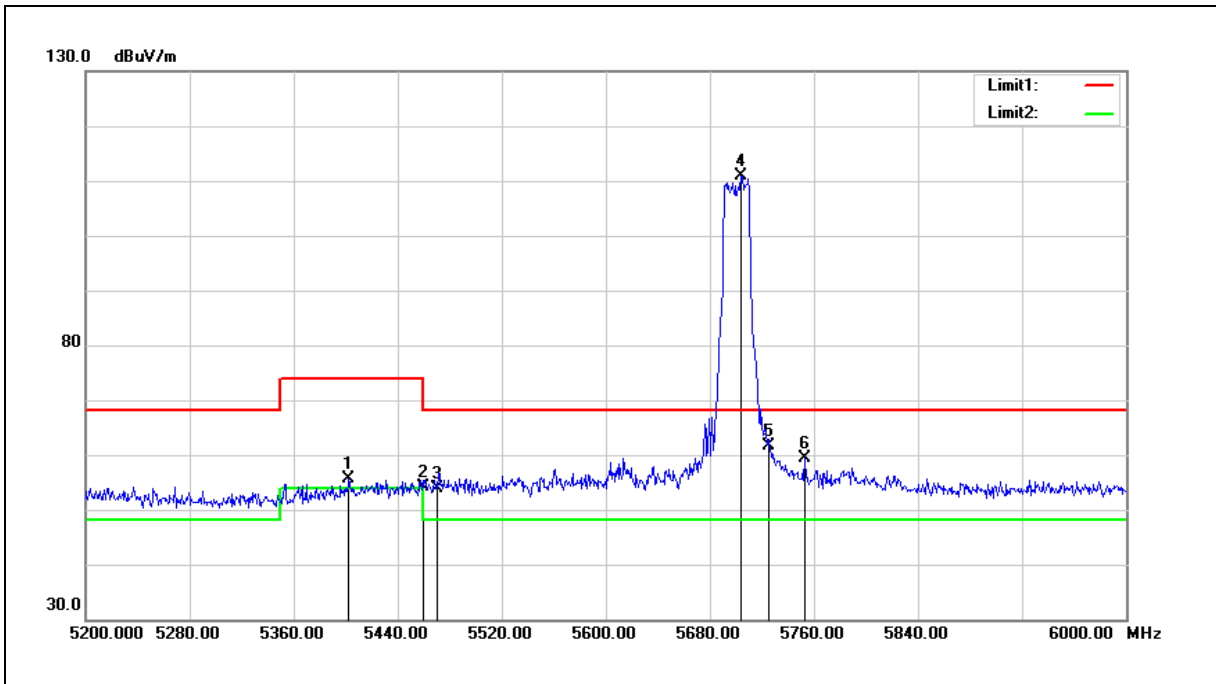

No.	Frequency (MHz)	Reading (dBuV)	Correct Factor (dB/m)	Result (dBuV/m)	Limit (dBuV/m)	Margin (dB)	Remark
1	5402.400	49.50	6.07	55.57	74.00	-18.43	peak
2	5460.000	48.00	6.14	54.14	74.00	-19.86	peak
3	5470.000	47.77	6.15	53.92	68.20	-14.28	peak
4	5704.000	104.13	6.70	110.83	68.20	42.63	peak
5	5725.000	54.76	6.76	61.52	68.20	-6.68	peak
6	5752.800	52.47	6.81	59.28	68.20	-8.92	peak

Note:1.Result (dBuV/m) = Correct Factor (dB/m) + Reading(dBuV).

2.Correction factor (dB/m) = Antenna Factor (dB/m) + Cable loss (dB) – Pre-Amplifier gain (dB).

3.When the peak results are less than average limit, so not need to evaluate the average.

Standard:	FCC Part 15.407	Test Distance:	3 m
Test item:	Band edge		
Frequency:	5700 MHz		
Mode:	Mode 8		
Ant.Polar.:	Vertical		

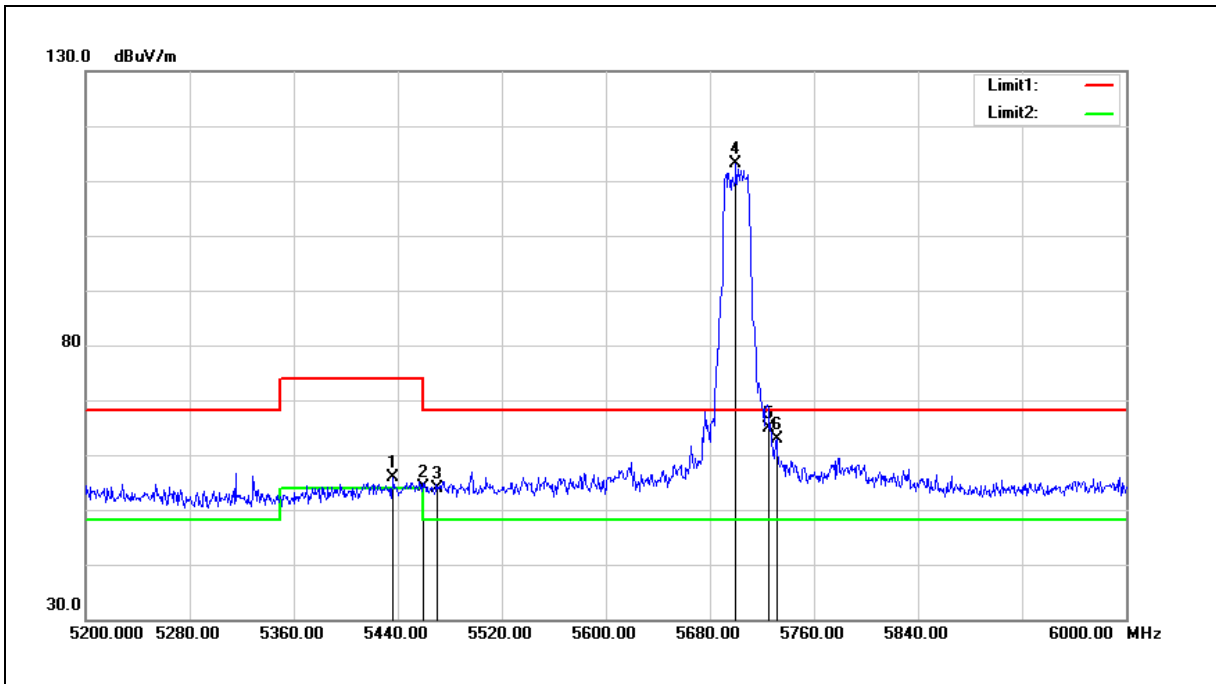

No.	Frequency (MHz)	Reading (dBuV)	Correct Factor (dB/m)	Result (dBuV/m)	Limit (dBuV/m)	Margin (dB)	Remark
1	5436.000	49.77	6.12	55.89	74.00	-18.11	peak
2	5460.000	47.90	6.14	54.04	74.00	-19.96	peak
3	5470.000	47.70	6.15	53.85	68.20	-14.35	peak
4	5700.000	106.42	6.69	113.11	68.20	44.91	peak
5	5725.000	58.03	6.76	64.79	68.20	-3.41	peak
6	5731.200	56.13	6.76	62.89	68.20	-5.31	peak

Note:1.Result (dBuV/m) = Correct Factor (dB/m) + Reading(dBuV).

2.Correction factor (dB/m) = Antenna Factor (dB/m) + Cable loss (dB) – Pre-Amplifier gain (dB).

3.When the peak results are less than average limit, so not need to evaluate the average.

Standard:	FCC Part 15.407	Test Distance:	3 m
Test item:	Band edge		
Frequency:	5720 MHz		
Mode:	Mode 8		
Ant.Polar.:	Horizontal		

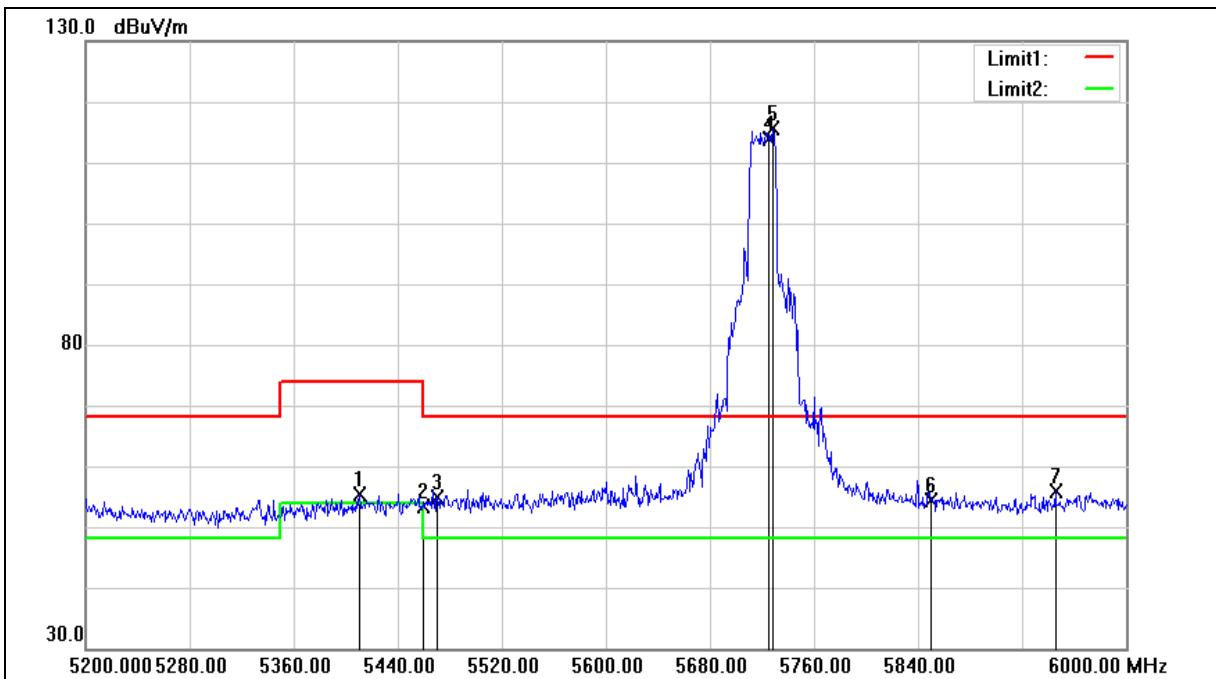

Standard:	FCC Part 15.407	Test Distance:	3 m
Test item:	Band edge		
Frequency:	5720 MHz		
Mode:	Mode 8		
Ant.Polar.:	Horizontal		

No.	Frequency (MHz)	Reading (dBuV)	Correct Factor (dB/m)	Result (dBuV/m)	Limit (dBuV/m)	Margin (dB)	Remark
1	5410.400	49.26	6.08	55.34	74.00	-18.66	peak
2	5460.000	47.15	6.14	53.29	74.00	-20.71	peak
3	5470.000	48.65	6.15	54.80	68.20	-13.40	peak
4	5725.000	107.22	6.76	113.98	68.20	45.78	peak
5	5728.800	108.85	6.76	115.61	68.20	47.41	peak
6	5850.000	47.30	7.05	54.35	68.20	-13.85	peak
7	5945.600	48.51	7.30	55.81	68.20	-12.39	peak

Note:1.Result (dBuV/m) = Correct Factor (dB/m) + Reading(dBuV).

2.Correction factor (dB/m) = Antenna Factor (dB/m) + Cable loss (dB) – Pre-Amplifier gain (dB).

3.When the peak results are less than average limit, so not need to evaluate the average.

Standard:	FCC Part 15.407	Test Distance:	3 m
Test item:	Band edge		
Frequency:	5720 MHz		
Mode:	Mode 8		
Ant.Polar.:	Vertical		

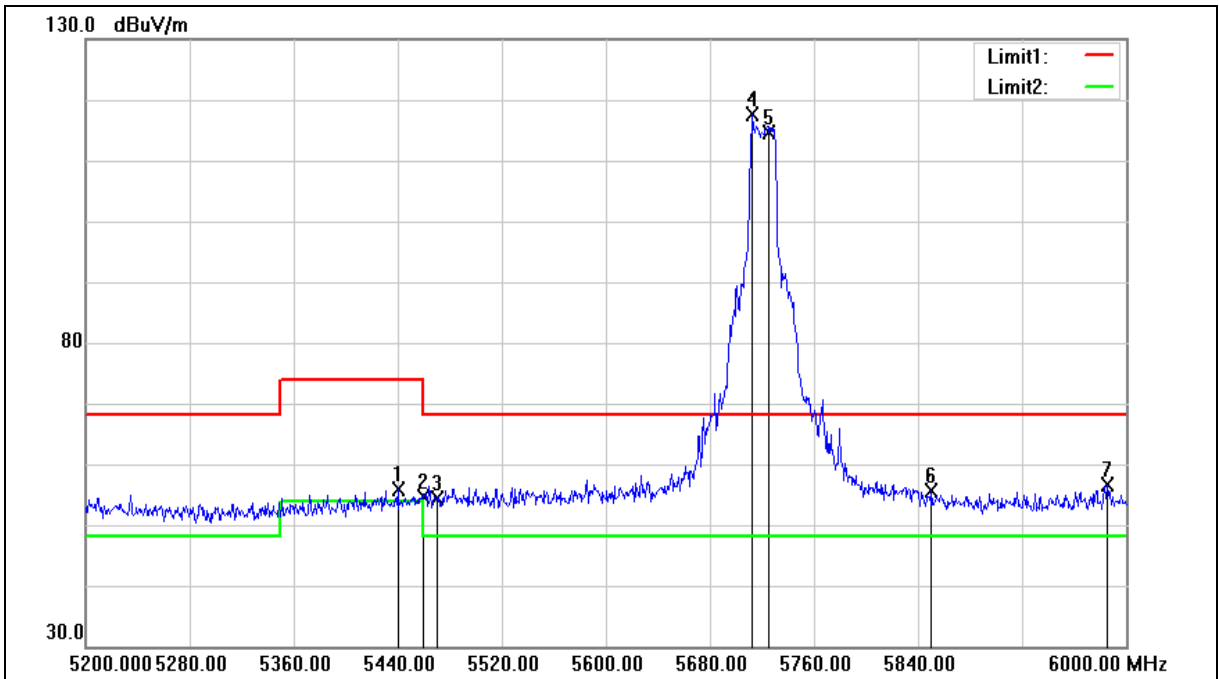

Standard:	FCC Part 15.407	Test Distance:	3 m
Test item:	Band edge		
Frequency:	5720 MHz		
Mode:	Mode 8		
Ant.Polar.:	Vertical		

No.	Frequency (MHz)	Reading (dBuV)	Correct Factor (dB/m)	Result (dBuV/m)	Limit (dBuV/m)	Margin (dB)	Remark
1	5440.000	49.67	6.12	55.79	74.00	-18.21	peak
2	5460.000	48.52	6.14	54.66	74.00	-19.34	peak
3	5470.000	48.19	6.15	54.34	68.20	-13.86	peak
4	5712.800	110.89	6.72	117.61	68.20	49.41	peak
5	5725.000	107.85	6.76	114.61	68.20	46.41	peak
6	5850.000	48.51	7.05	55.56	68.20	-12.64	peak
7	5985.600	49.31	7.39	56.70	68.20	-11.50	peak

Note:1.Result (dBuV/m) = Correct Factor (dB/m) + Reading(dBuV).

2.Correction factor (dB/m) = Antenna Factor (dB/m) + Cable loss (dB) – Pre-Amplifier gain (dB).

3.When the peak results are less than average limit, so not need to evaluate the average.

Standard:	FCC Part 15.407	Test Distance:	3 m
Test item:	Band edge		
Frequency:	5270 MHz		
Mode:	Mode 9		
Ant.Polar.:	Horizontal		

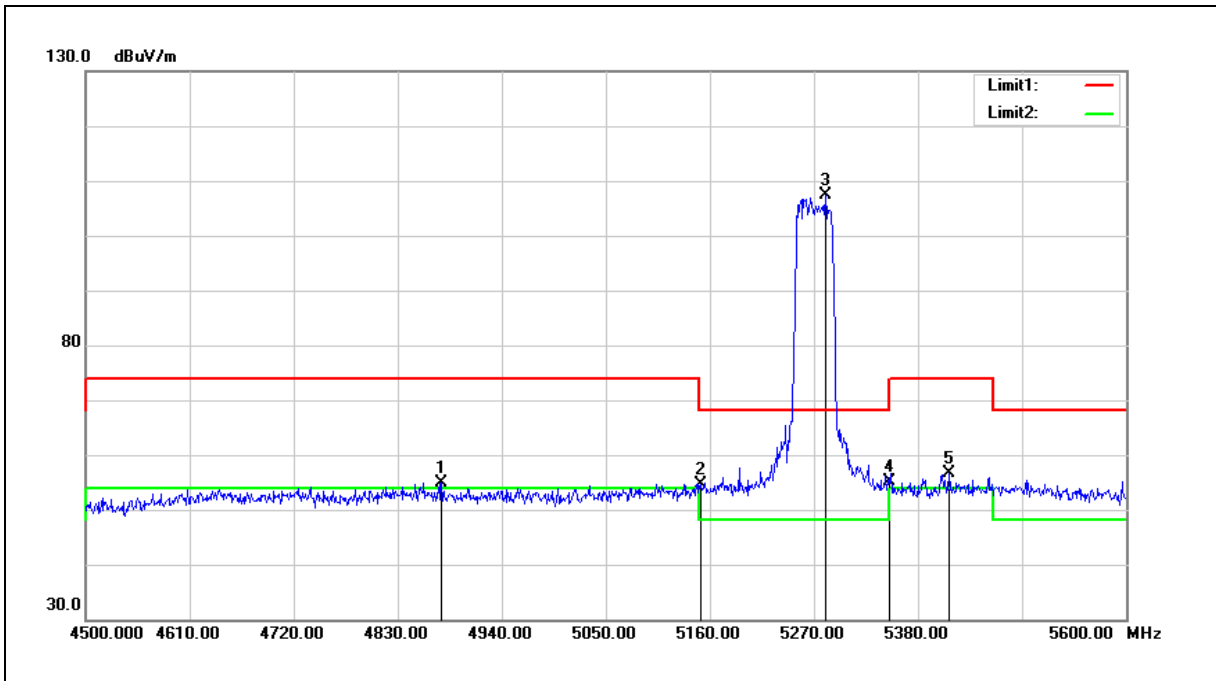

No.	Frequency (MHz)	Reading (dBuV)	Correct Factor (dB/m)	Result (dBuV/m)	Limit (dBuV/m)	Margin (dB)	Remark
1	4876.200	49.69	5.23	54.92	74.00	-19.08	peak
2	5150.000	48.96	5.75	54.71	74.00	-19.29	peak
3	5282.100	101.39	5.92	107.31	68.20	39.11	peak
4	5350.000	49.11	6.00	55.11	74.00	-18.89	peak
5	5413.000	50.43	6.08	56.51	74.00	-17.49	peak

Note:1.Result (dBuV/m) = Correct Factor (dB/m) + Reading(dBuV).

2.Correction factor (dB/m) = Antenna Factor (dB/m) + Cable loss (dB) – Pre-Amplifier gain (dB).

3.When the peak results are less than average limit, so not need to evaluate the average.

Standard:	FCC Part 15.407	Test Distance:	3 m
Test item:	Band edge		
Frequency:	5270 MHz		
Mode:	Mode 9		
Ant.Polar.:	Vertical		

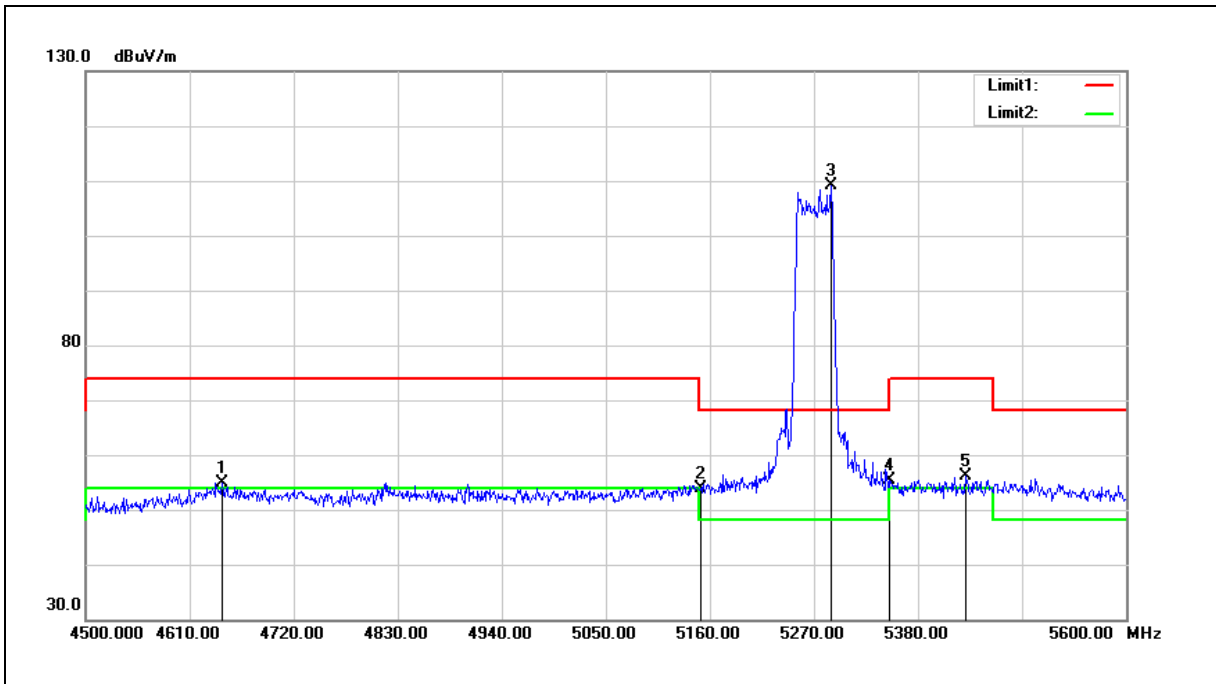

No.	Frequency (MHz)	Reading (dBuV)	Correct Factor (dB/m)	Result (dBuV/m)	Limit (dBuV/m)	Margin (dB)	Remark
1	4644.100	50.39	4.60	54.99	74.00	-19.01	peak
2	5150.000	48.11	5.75	53.86	74.00	-20.14	peak
3	5288.700	103.26	5.93	109.19	68.20	40.99	peak
4	5350.000	49.35	6.00	55.35	74.00	-18.65	peak
5	5430.600	50.01	6.10	56.11	74.00	-17.89	peak

Note:1.Result (dBuV/m) = Correct Factor (dB/m) + Reading(dBuV).

2.Correction factor (dB/m) = Antenna Factor (dB/m) + Cable loss (dB) – Pre-Amplifier gain (dB).

3.When the peak results are less than average limit, so not need to evaluate the average.

Standard:	FCC Part 15.407	Test Distance:	3 m
Test item:	Band edge		
Frequency:	5310 MHz		
Mode:	Mode 9		
Ant.Polar.:	Horizontal		

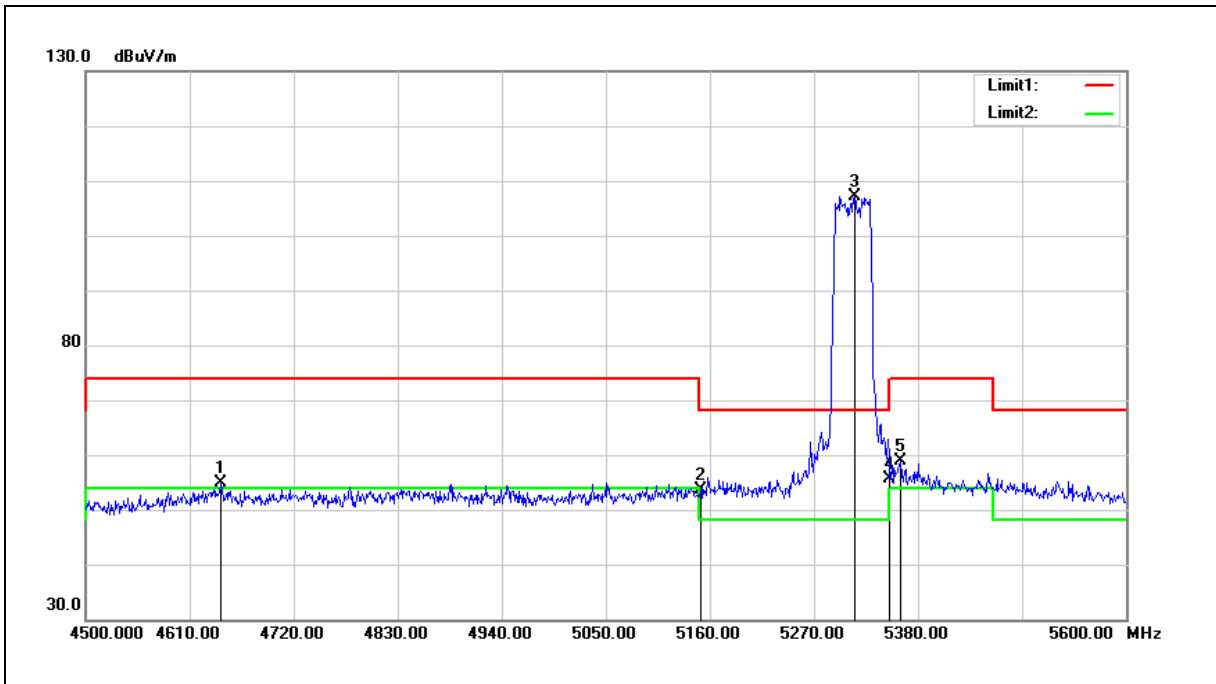

No.	Frequency (MHz)	Reading (dBuV)	Correct Factor (dB/m)	Result (dBuV/m)	Limit (dBuV/m)	Margin (dB)	Remark
1	4643.000	50.26	4.60	54.86	74.00	-19.14	peak
2	5150.000	47.83	5.75	53.58	74.00	-20.42	peak
3	5312.900	101.12	5.96	107.08	68.20	38.88	peak
4	5350.000	49.72	6.00	55.72	74.00	-18.28	peak
5	5361.300	52.83	6.02	58.85	74.00	-15.15	peak

Note:1.Result (dBuV/m) = Correct Factor (dB/m) + Reading(dBuV).

2.Correction factor (dB/m) = Antenna Factor (dB/m) + Cable loss (dB) – Pre-Amplifier gain (dB).

3.When the peak results are less than average limit, so not need to evaluate the average.

Standard:	FCC Part 15.407	Test Distance:	3 m
Test item:	Band edge		
Frequency:	5310 MHz		
Mode:	Mode 9		
Ant.Polar.:	Vertical		

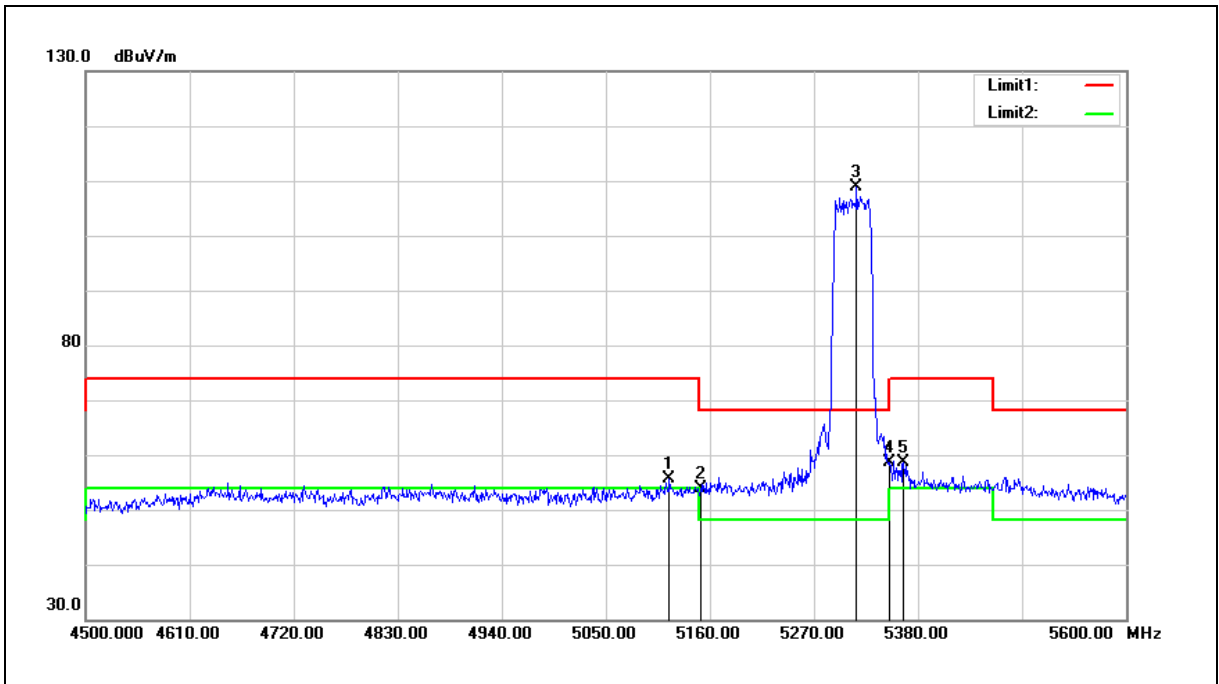

No.	Frequency (MHz)	Reading (dBuV)	Correct Factor (dB/m)	Result (dBuV/m)	Limit (dBuV/m)	Margin (dB)	Remark
1	5117.100	49.99	5.71	55.70	74.00	-18.30	peak
2	5150.000	48.09	5.75	53.84	74.00	-20.16	peak
3	5315.100	102.86	5.96	108.82	68.20	40.62	peak
4	5350.000	52.63	6.00	58.63	74.00	-15.37	peak
5	5364.600	52.59	6.02	58.61	74.00	-15.39	peak

Note:1.Result (dBuV/m) = Correct Factor (dB/m) + Reading(dBuV).

2.Correction factor (dB/m) = Antenna Factor (dB/m) + Cable loss (dB) – Pre-Amplifier gain (dB).

3.When the peak results are less than average limit, so not need to evaluate the average.

Standard:	FCC Part 15.407	Test Distance:	3 m
Test item:	Band edge		
Frequency:	5510 MHz		
Mode:	Mode 9		
Ant.Polar.:	Horizontal		

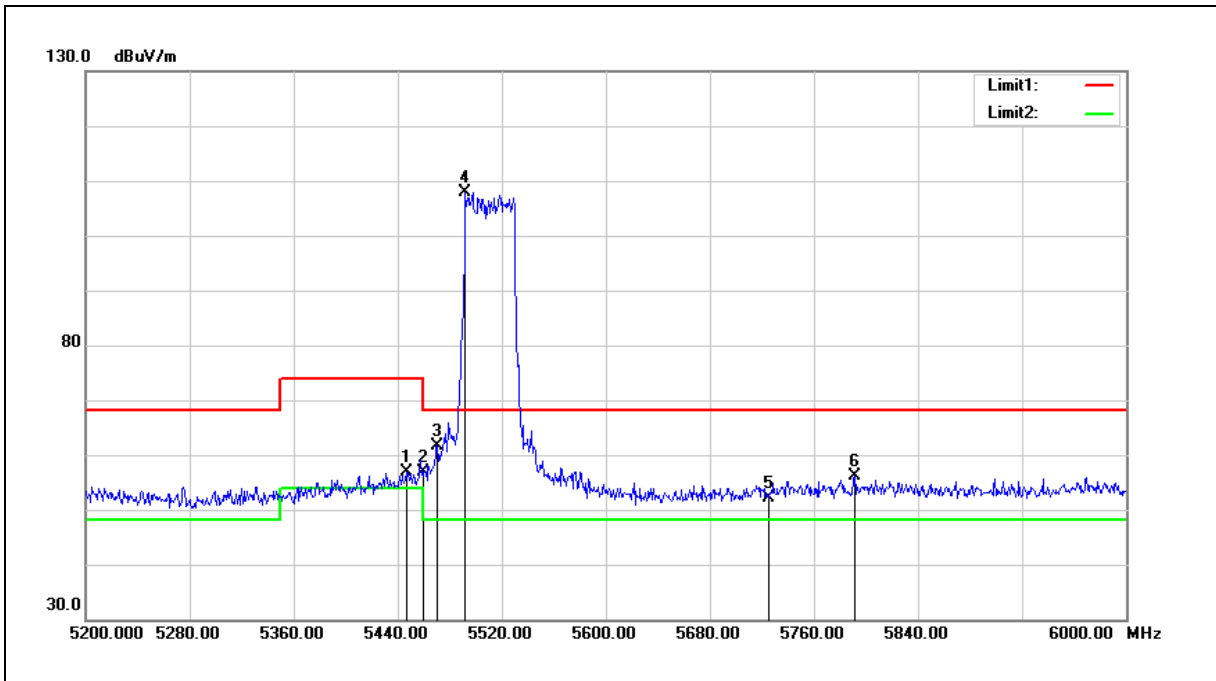

No.	Frequency (MHz)	Reading (dBuV)	Correct Factor (dB/m)	Result (dBuV/m)	Limit (dBuV/m)	Margin (dB)	Remark
1	5446.400	50.68	6.13	56.81	74.00	-17.19	peak
2	5460.000	50.82	6.14	56.96	74.00	-17.04	peak
3	5470.000	55.45	6.15	61.60	68.20	-6.60	peak
4	5492.000	101.76	6.18	107.94	68.20	39.74	peak
5	5725.000	45.31	6.76	52.07	68.20	-16.13	peak
6	5791.200	49.17	6.91	56.08	68.20	-12.12	peak

Note:1.Result (dBuV/m) = Correct Factor (dB/m) + Reading(dBuV).

2.Correction factor (dB/m) = Antenna Factor (dB/m) + Cable loss (dB) – Pre-Amplifier gain (dB).

3.When the peak results are less than average limit, so not need to evaluate the average.

Standard:	FCC Part 15.407	Test Distance:	3 m
Test item:	Band edge		
Frequency:	5510 MHz		
Mode:	Mode 9		
Ant.Polar.:	Vertical		

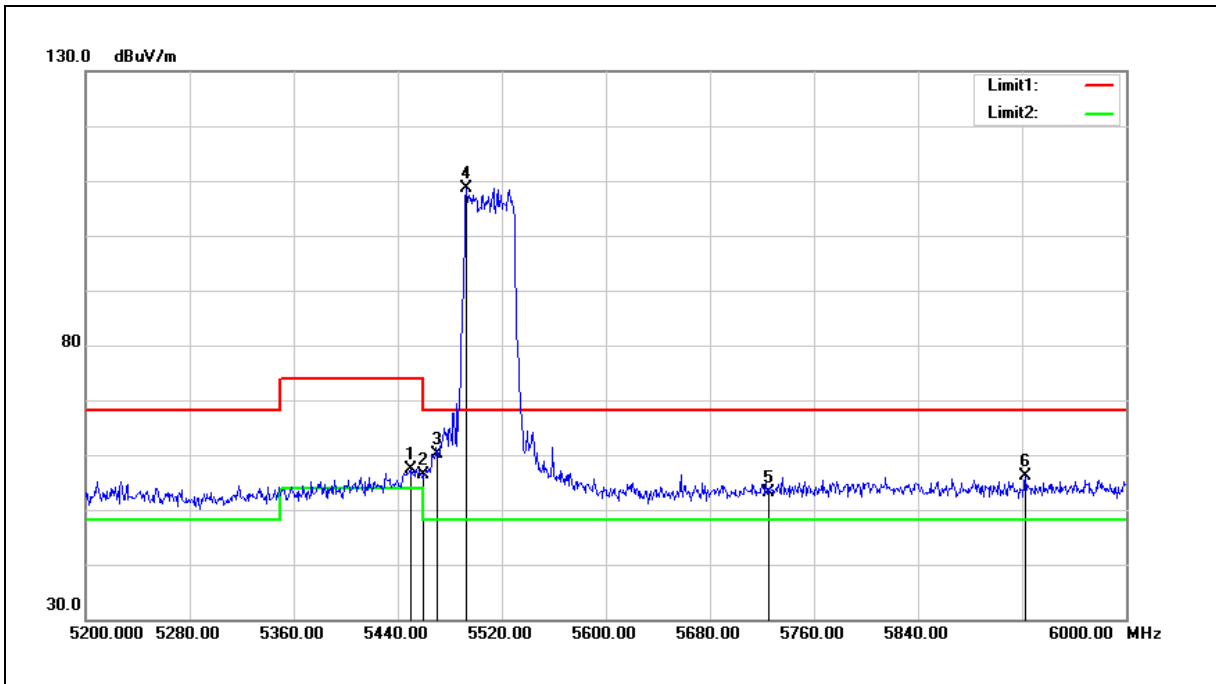

No.	Frequency (MHz)	Reading (dBuV)	Correct Factor (dB/m)	Result (dBuV/m)	Limit (dBuV/m)	Margin (dB)	Remark
1	5449.600	51.13	6.13	57.26	74.00	-16.74	peak
2	5460.000	50.15	6.14	56.29	74.00	-17.71	peak
3	5470.000	54.10	6.15	60.25	68.20	-7.95	peak
4	5492.800	102.47	6.18	108.65	68.20	40.45	peak
5	5725.000	46.36	6.76	53.12	68.20	-15.08	peak
6	5922.400	48.96	7.24	56.20	68.20	-12.00	peak

Note:1.Result (dBuV/m) = Correct Factor (dB/m) + Reading(dBuV).

2.Correction factor (dB/m) = Antenna Factor (dB/m) + Cable loss (dB) – Pre-Amplifier gain (dB).

3.When the peak results are less than average limit, so not need to evaluate the average.

Standard:	FCC Part 15.407	Test Distance:	3 m
Test item:	Band edge		
Frequency:	5550 MHz		
Mode:	Mode 9		
Ant.Polar.:	Horizontal		

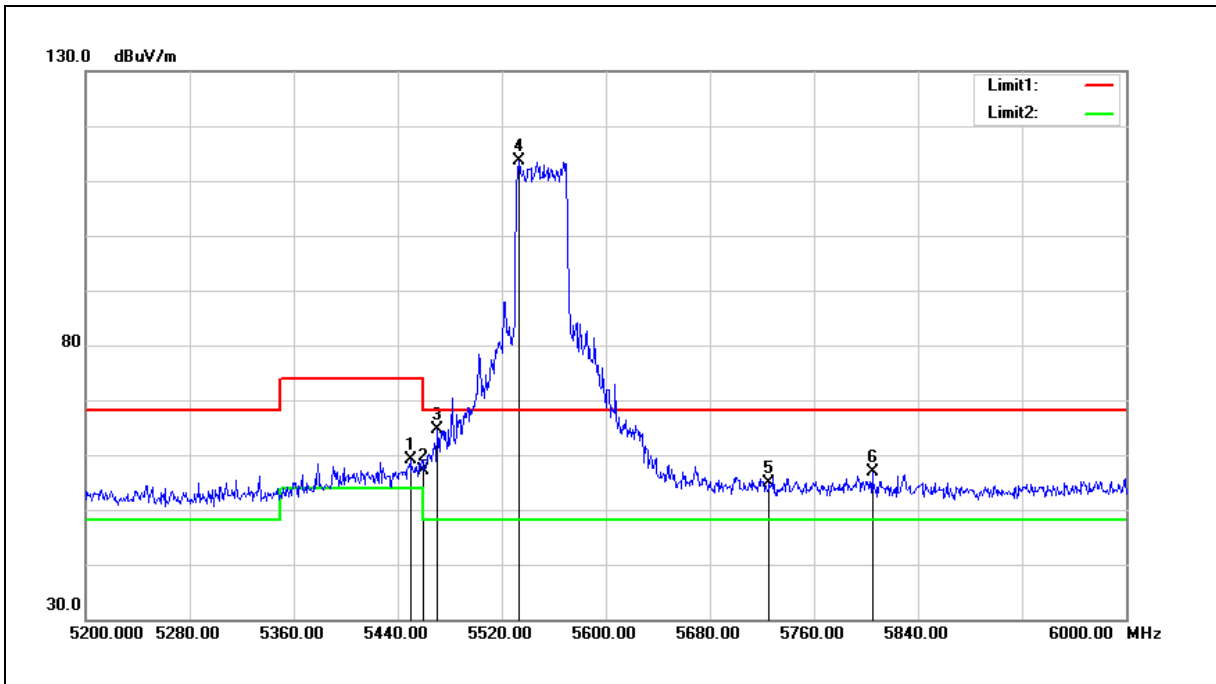

No.	Frequency (MHz)	Reading (dBuV)	Correct Factor (dB/m)	Result (dBuV/m)	Limit (dBuV/m)	Margin (dB)	Remark
1	5449.600	53.11	6.13	59.24	74.00	-14.76	peak
2	5460.000	50.95	6.14	57.09	74.00	-16.91	peak
3	5470.000	58.46	6.15	64.61	68.20	-3.59	peak
4	5533.600	107.36	6.28	113.64	68.20	45.44	peak
5	5725.000	48.08	6.76	54.84	68.20	-13.36	peak
6	5804.800	49.86	6.95	56.81	68.20	-11.39	peak

Note:1.Result (dBuV/m) = Correct Factor (dB/m) + Reading(dBuV).

2.Correction factor (dB/m) = Antenna Factor (dB/m) + Cable loss (dB) – Pre-Amplifier gain (dB).

3.When the peak results are less than average limit, so not need to evaluate the average.

Standard:	FCC Part 15.407	Test Distance:	3 m
Test item:	Band edge		
Frequency:	5550 MHz		
Mode:	Mode 9		
Ant.Polar.:	Vertical		

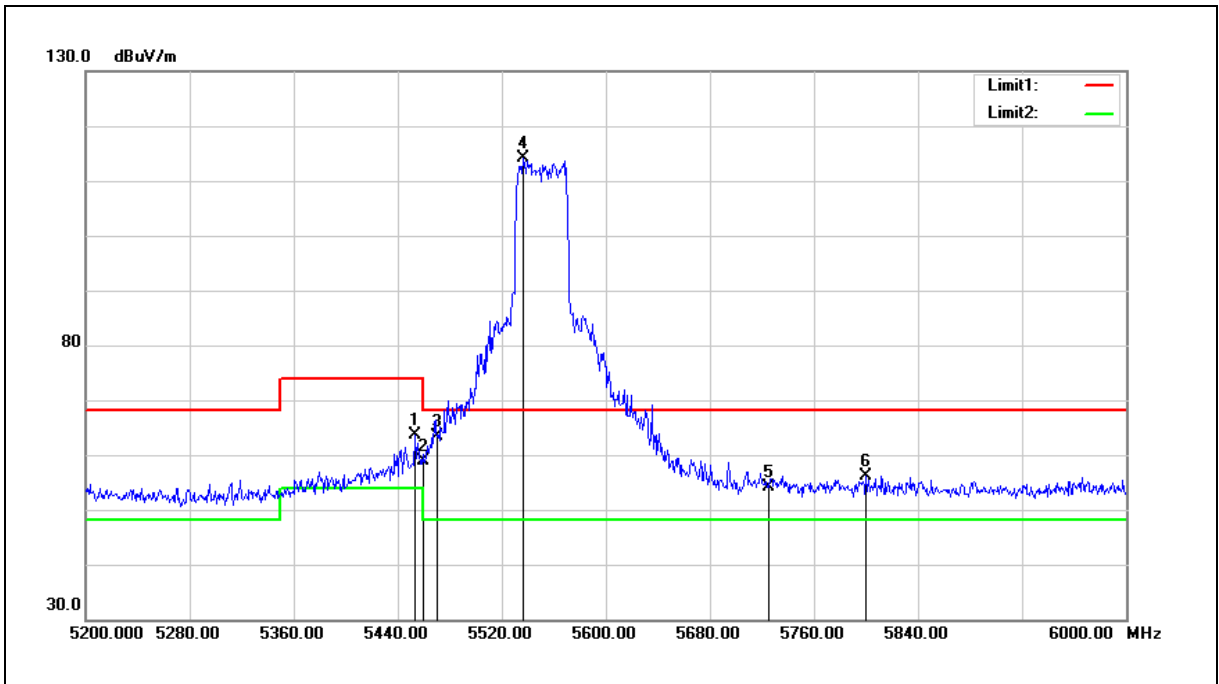

No.	Frequency (MHz)	Reading (dBuV)	Correct Factor (dB/m)	Result (dBuV/m)	Limit (dBuV/m)	Margin (dB)	Remark
1	5453.600	57.48	6.12	63.60	74.00	-10.40	peak
2	5460.000	52.78	6.14	58.92	74.00	-15.08	peak
3	5470.000	57.25	6.15	63.40	68.20	-4.80	peak
4	5536.800	107.85	6.28	114.13	68.20	45.93	peak
5	5725.000	47.41	6.76	54.17	68.20	-14.03	peak
6	5800.000	49.27	6.93	56.20	68.20	-12.00	peak

Note:1.Result (dBuV/m) = Correct Factor (dB/m) + Reading(dBuV).

2.Correction factor (dB/m) = Antenna Factor (dB/m) + Cable loss (dB) – Pre-Amplifier gain (dB).

3.When the peak results are less than average limit, so not need to evaluate the average.

Standard:	FCC Part 15.407	Test Distance:	3 m
Test item:	Band edge		
Frequency:	5670 MHz		
Mode:	Mode 9		
Ant.Polar.:	Horizontal		

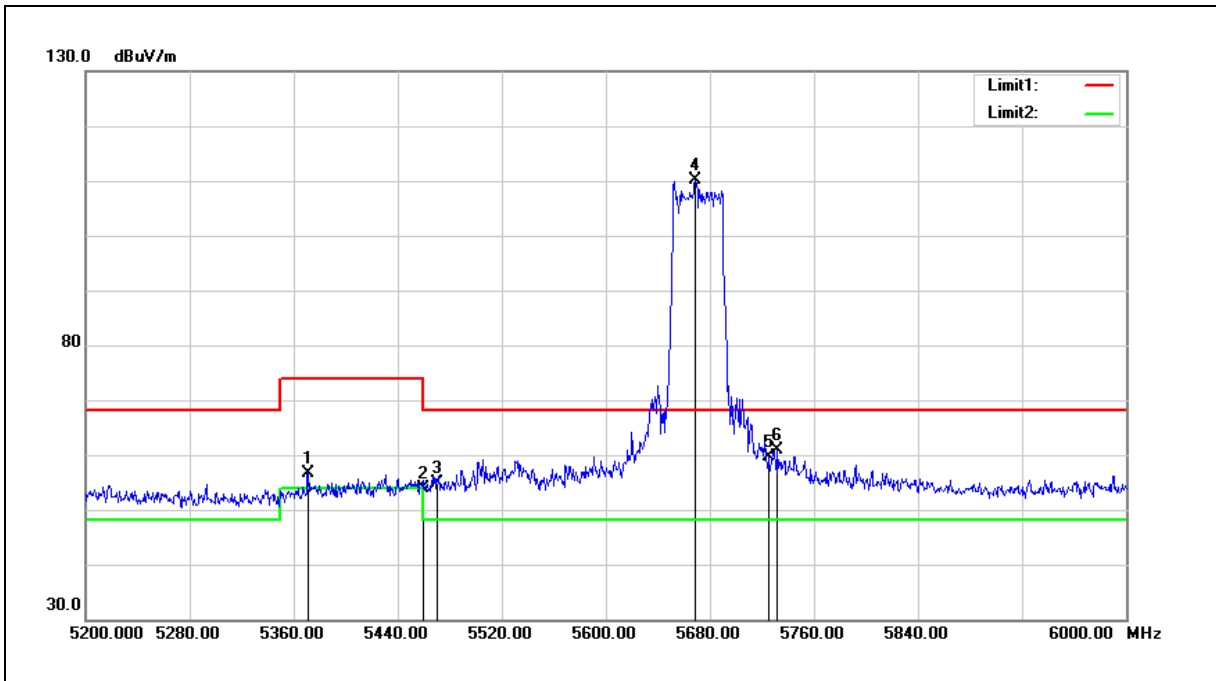

No.	Frequency (MHz)	Reading (dBuV)	Correct Factor (dB/m)	Result (dBuV/m)	Limit (dBuV/m)	Margin (dB)	Remark
1	5371.200	50.54	6.03	56.57	74.00	-17.43	peak
2	5460.000	47.75	6.14	53.89	74.00	-20.11	peak
3	5470.000	48.85	6.15	55.00	68.20	-13.20	peak
4	5668.800	103.50	6.61	110.11	68.20	41.91	peak
5	5725.000	52.90	6.76	59.66	68.20	-8.54	peak
6	5732.000	54.23	6.76	60.99	68.20	-7.21	peak

Note:1.Result (dBuV/m) = Correct Factor (dB/m) + Reading(dBuV).

2.Correction factor (dB/m) = Antenna Factor (dB/m) + Cable loss (dB) – Pre-Amplifier gain (dB).

3.When the peak results are less than average limit, so not need to evaluate the average.

Standard:	FCC Part 15.407	Test Distance:	3 m
Test item:	Band edge		
Frequency:	5670 MHz		
Mode:	Mode 9		
Ant.Polar.:	Vertical		

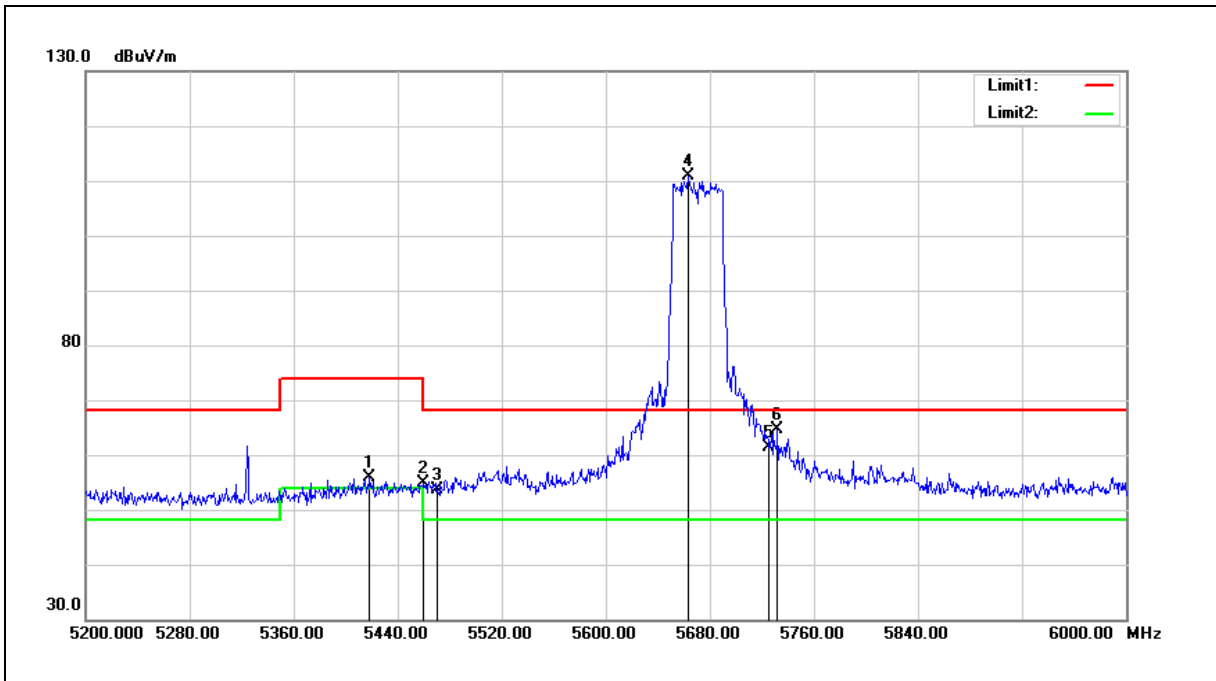

No.	Frequency (MHz)	Reading (dBuV)	Correct Factor (dB/m)	Result (dBuV/m)	Limit (dBuV/m)	Margin (dB)	Remark
1	5418.400	49.84	6.09	55.93	74.00	-18.07	peak
2	5460.000	48.81	6.14	54.95	74.00	-19.05	peak
3	5470.000	47.42	6.15	53.57	68.20	-14.63	peak
4	5663.200	104.26	6.59	110.85	68.20	42.65	peak
5	5725.000	54.58	6.76	61.34	68.20	-6.86	peak
6	5732.000	57.92	6.76	64.68	68.20	-3.52	peak

Note:1.Result (dBuV/m) = Correct Factor (dB/m) + Reading(dBuV).

2.Correction factor (dB/m) = Antenna Factor (dB/m) + Cable loss (dB) – Pre-Amplifier gain (dB).

3.When the peak results are less than average limit, so not need to evaluate the average.

Standard:	FCC Part 15.407	Test Distance:	3 m
Test item:	Band edge		
Frequency:	5710 MHz		
Mode:	Mode 9		
Ant.Polar.:	Horizontal		

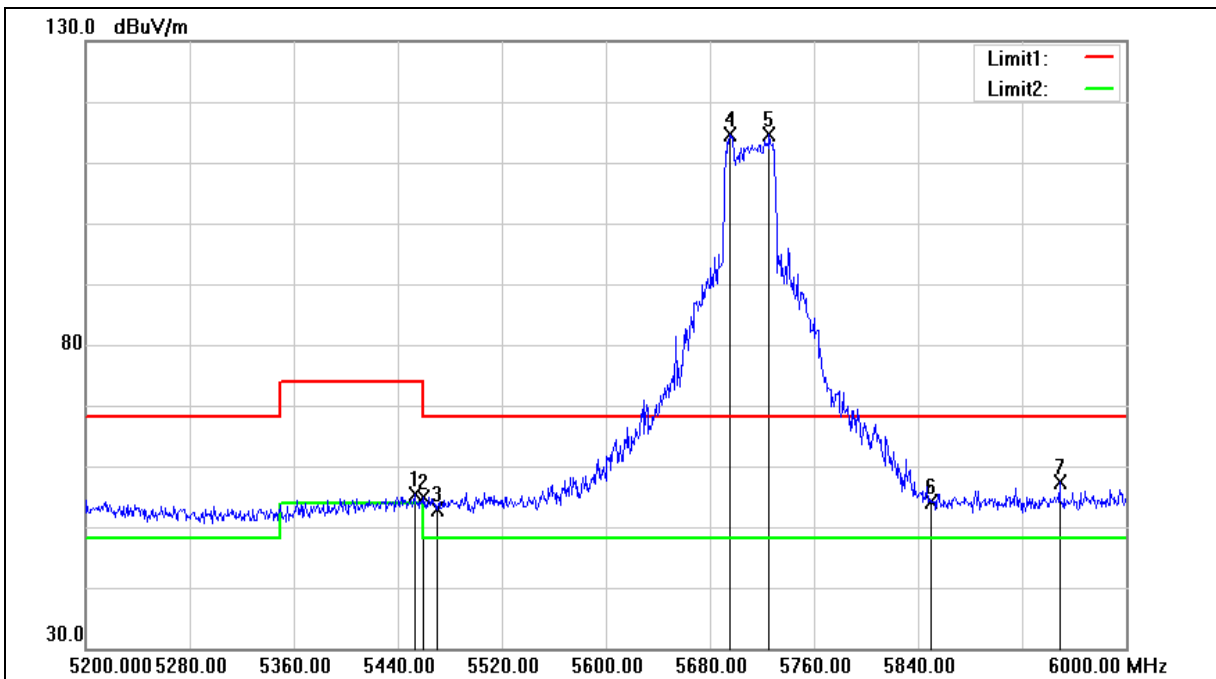

Standard:	FCC Part 15.407	Test Distance:	3 m
Test item:	Band edge		
Frequency:	5710 MHz		
Mode:	Mode 9		
Ant.Polar.:	Horizontal		

No.	Frequency (MHz)	Reading (dBuV)	Correct Factor (dB/m)	Result (dBuV/m)	Limit (dBuV/m)	Margin (dB)	Remark
1	5452.800	49.16	6.12	55.28	74.00	-18.72	peak
2	5460.000	48.80	6.14	54.94	74.00	-19.06	peak
3	5470.000	46.67	6.15	52.82	68.20	-15.38	peak
4	5695.200	108.00	6.67	114.67	68.20	46.47	peak
5	5725.000	107.83	6.76	114.59	68.20	46.39	peak
6	5850.000	46.97	7.05	54.02	68.20	-14.18	peak
7	5948.800	49.96	7.31	57.27	68.20	-10.93	peak

Note:1.Result (dBuV/m) = Correct Factor (dB/m) + Reading(dBuV).

2.Correction factor (dB/m) = Antenna Factor (dB/m) + Cable loss (dB) – Pre-Amplifier gain (dB).

3.When the peak results are less than average limit, so not need to evaluate the average.

Standard:	FCC Part 15.407	Test Distance:	3 m
Test item:	Band edge		
Frequency:	5710 MHz		
Mode:	Mode 9		
Ant.Polar.:	Vertical		

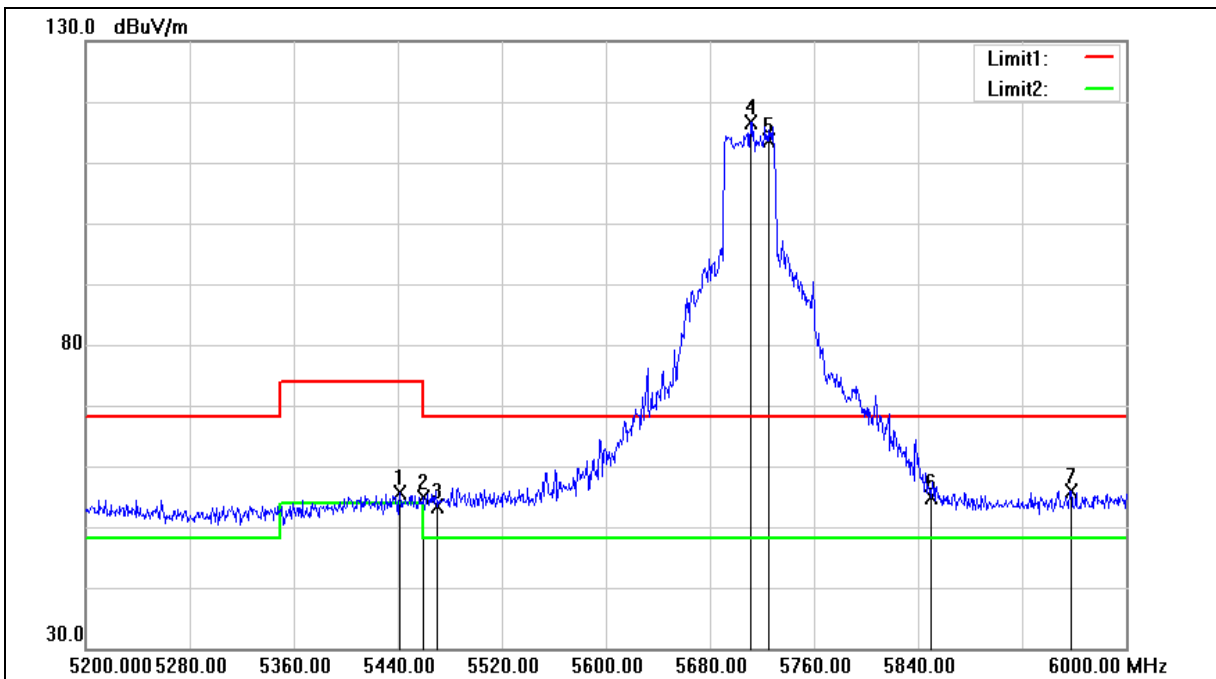

Standard:	FCC Part 15.407	Test Distance:	3 m
Test item:	Band edge		
Frequency:	5710 MHz		
Mode:	Mode 9		
Ant.Polar.:	Vertical		

No.	Frequency (MHz)	Reading (dBuV)	Correct Factor (dB/m)	Result (dBuV/m)	Limit (dBuV/m)	Margin (dB)	Remark
1	5441.600	49.53	6.12	55.65	74.00	-18.35	peak
2	5460.000	48.62	6.14	54.76	74.00	-19.24	peak
3	5470.000	47.13	6.15	53.28	68.20	-14.92	peak
4	5711.200	109.94	6.72	116.66	68.20	48.46	peak
5	5725.000	106.89	6.76	113.65	68.20	45.45	peak
6	5850.000	47.74	7.05	54.79	68.20	-13.41	peak
7	5957.600	48.56	7.32	55.88	68.20	-12.32	peak

Note:1.Result (dBuV/m) = Correct Factor (dB/m) + Reading(dBuV).

2.Correction factor (dB/m) = Antenna Factor (dB/m) + Cable loss (dB) – Pre-Amplifier gain (dB).

3.When the peak results are less than average limit, so not need to evaluate the average.

Standard:	FCC Part 15.407	Test Distance:	3 m
Test item:	Band edge		
Frequency:	5290 MHz		
Mode:	Mode 10		
Ant.Polar.:	Horizontal		

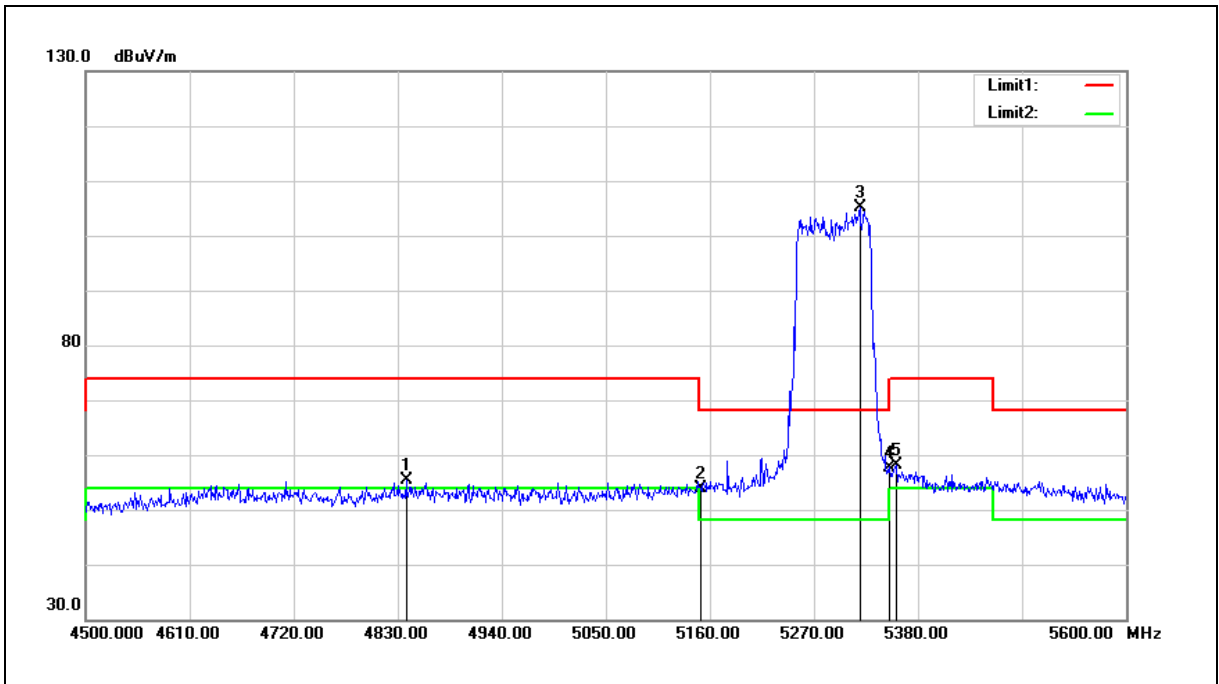

No.	Frequency (MHz)	Reading (dBuV)	Correct Factor (dB/m)	Result (dBuV/m)	Limit (dBuV/m)	Margin (dB)	Remark
1	4838.800	50.22	5.11	55.33	74.00	-18.67	peak
2	5150.000	48.07	5.81	53.88	74.00	-20.12	peak
3	5318.400	99.21	6.00	105.21	68.20	37.01	peak
4	5350.000	51.68	6.03	57.71	74.00	-16.29	peak
5	5356.900	52.02	6.05	58.07	74.00	-15.93	peak

Note:1.Result (dBuV/m) = Correct Factor (dB/m) + Reading(dBuV).

2.Correction factor (dB/m) = Antenna Factor (dB/m) + Cable loss (dB) – Pre-Amplifier gain (dB).

3.When the peak results are less than average limit, so not need to evaluate the average.

Standard:	FCC Part 15.407	Test Distance:	3 m
Test item:	Band edge		
Frequency:	5290 MHz		
Mode:	Mode 10		
Ant.Polar.:	Vertical		

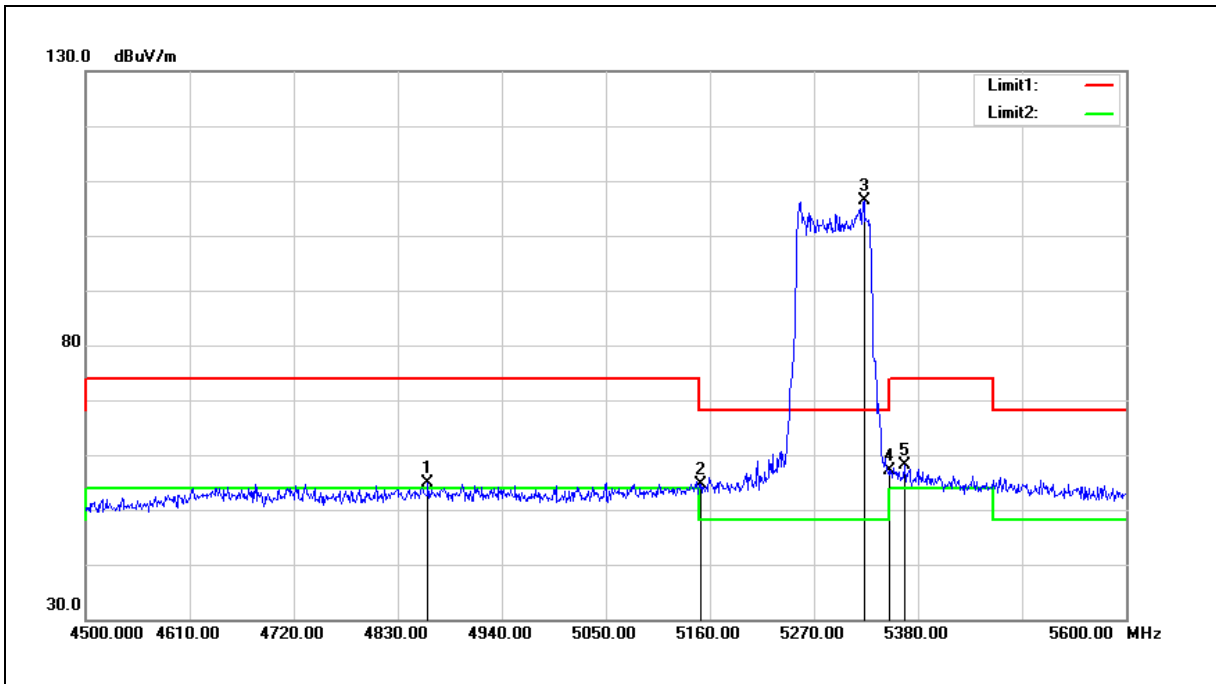

No.	Frequency (MHz)	Reading (dBuV)	Correct Factor (dB/m)	Result (dBuV/m)	Limit (dBuV/m)	Margin (dB)	Remark
1	4861.900	49.65	5.19	54.84	74.00	-19.16	peak
2	5150.000	48.82	5.81	54.63	74.00	-19.37	peak
3	5322.800	100.43	6.01	106.44	68.20	38.24	peak
4	5350.000	51.19	6.03	57.22	74.00	-16.78	peak
5	5365.700	52.07	6.05	58.12	74.00	-15.88	peak

Note:1.Result (dBuV/m) = Correct Factor (dB/m) + Reading(dBuV).

2.Correction factor (dB/m) = Antenna Factor (dB/m) + Cable loss (dB) – Pre-Amplifier gain (dB).

3.When the peak results are less than average limit, so not need to evaluate the average.

Standard:	FCC Part 15.407	Test Distance:	3 m
Test item:	Band edge		
Frequency:	5530 MHz		
Mode:	Mode 10		
Ant.Polar.:	Horizontal		

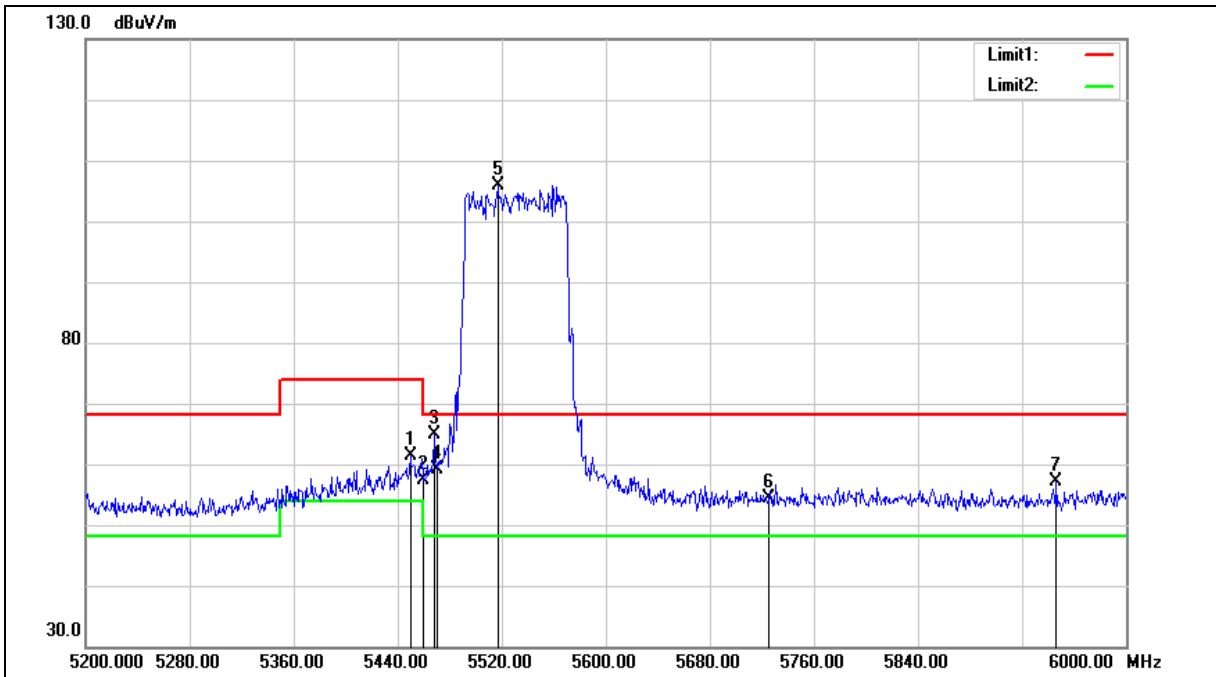

Standard:	FCC Part 15.407	Test Distance:	3 m
Test item:	Band edge		
Frequency:	5530 MHz		
Mode:	Mode 10		
Ant.Polar.:	Horizontal		

No.	Frequency (MHz)	Reading (dBuV)	Correct Factor (dB/m)	Result (dBuV/m)	Limit (dBuV/m)	Margin (dB)	Remark
1	5449.600	55.33	6.16	61.49	74.00	-12.51	peak
2	5460.000	51.33	6.16	57.49	74.00	-16.51	peak
3	5468.000	58.82	6.17	64.99	68.20	-3.21	peak
4	5470.000	52.89	6.18	59.07	68.20	-9.13	peak
5	5516.800	99.65	6.25	105.90	68.20	37.70	peak
6	5725.000	47.67	6.81	54.48	68.20	-13.72	peak
7	5946.400	49.68	7.39	57.07	68.20	-11.13	peak

Note:1.Result (dBuV/m) = Correct Factor (dB/m) + Reading(dBuV).

2.Correction factor (dB/m) = Antenna Factor (dB/m) + Cable loss (dB) – Pre-Amplifier gain (dB).

3.When the peak results are less than average limit, so not need to evaluate the average.

Standard:	FCC Part 15.407	Test Distance:	3 m
Test item:	Band edge		
Frequency:	5530 MHz		
Mode:	Mode 10		
Ant.Polar.:	Vertical		

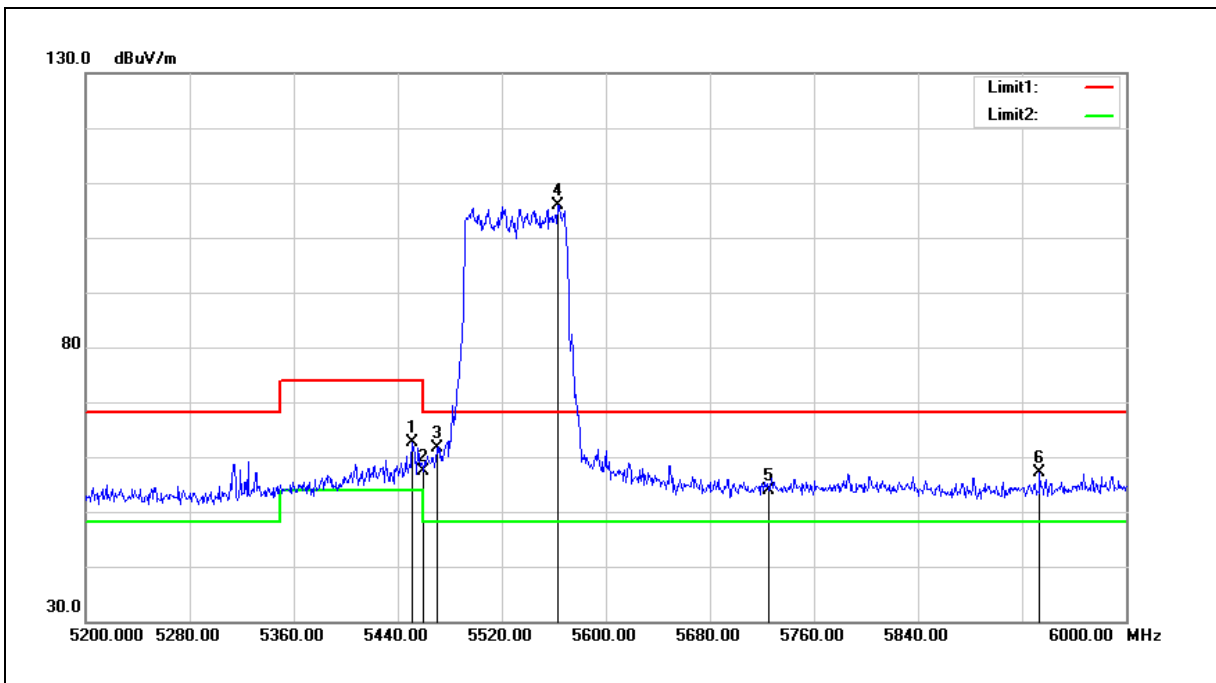

No.	Frequency (MHz)	Reading (dBuV)	Correct Factor (dB/m)	Result (dBuV/m)	Limit (dBuV/m)	Margin (dB)	Remark
1	5451.200	56.39	6.15	62.54	74.00	-11.46	peak
2	5460.000	51.27	6.16	57.43	74.00	-16.57	peak
3	5470.000	55.39	6.18	61.57	68.20	-6.63	peak
4	5563.200	99.45	6.37	105.82	68.20	37.62	peak
5	5725.000	47.01	6.81	53.82	68.20	-14.38	peak
6	5933.600	49.77	7.36	57.13	68.20	-11.07	peak

Note:1.Result (dBuV/m) = Correct Factor (dB/m) + Reading(dBuV).

2.Correction factor (dB/m) = Antenna Factor (dB/m) + Cable loss (dB) – Pre-Amplifier gain (dB).

3.When the peak results are less than average limit, so not need to evaluate the average.

Standard:	FCC Part 15.407	Test Distance:	3 m
Test item:	Band edge		
Frequency:	5610 MHz		
Mode:	Mode 10		
Ant.Polar.:	Horizontal		

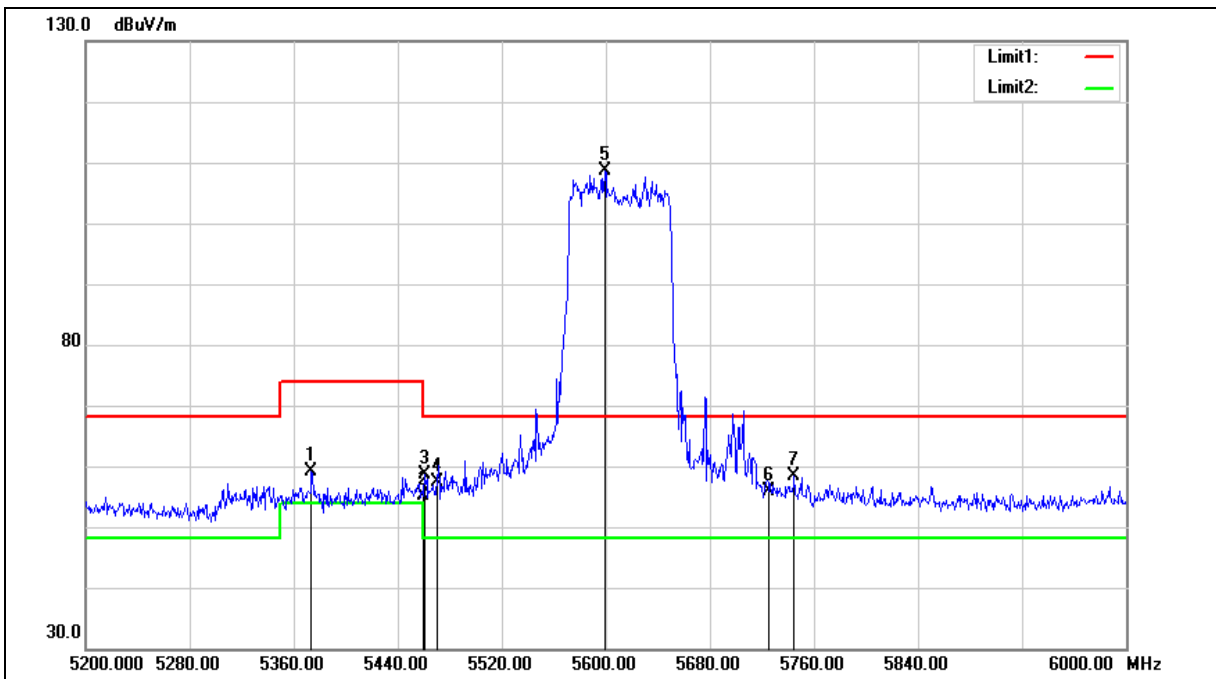

Standard:	FCC Part 15.407	Test Distance:	3 m
Test item:	Band edge		
Frequency:	5610 MHz		
Mode:	Mode 10		
Ant.Polar.:	Horizontal		

No.	Frequency (MHz)	Reading (dBuV)	Correct Factor (dB/m)	Result (dBuV/m)	Limit (dBuV/m)	Margin (dB)	Remark
1	5373.600	53.02	6.06	59.08	74.00	-14.92	peak
2	5460.000	49.06	6.16	55.22	74.00	-18.78	peak
3	5460.800	52.50	6.16	58.66	68.20	-9.54	peak
4	5470.000	51.08	6.18	57.26	68.20	-10.94	peak
5	5599.200	102.08	6.47	108.55	68.20	40.35	peak
6	5725.000	49.18	6.81	55.99	68.20	-12.21	peak
7	5744.800	51.55	6.86	58.41	68.20	-9.79	peak

Note:1.Result (dBuV/m) = Correct Factor (dB/m) + Reading(dBuV).

2.Correction factor (dB/m) = Antenna Factor (dB/m) + Cable loss (dB) – Pre-Amplifier gain (dB).

3.When the peak results are less than average limit, so not need to evaluate the average.

Standard:	FCC Part 15.407	Test Distance:	3 m
Test item:	Band edge		
Frequency:	5610 MHz		
Mode:	Mode 10		
Ant.Polar.:	Vertical		

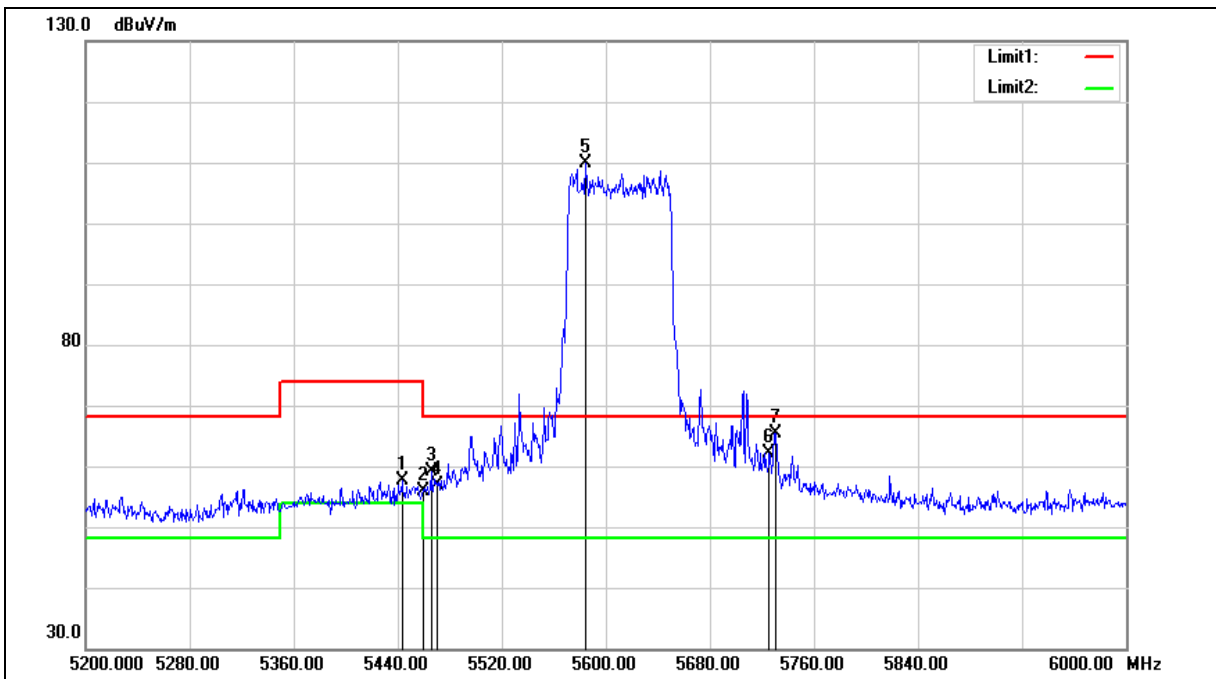

Standard:	FCC Part 15.407	Test Distance:	3 m
Test item:	Band edge		
Frequency:	5610 MHz		
Mode:	Mode 10		
Ant.Polar.:	Vertical		

No.	Frequency (MHz)	Reading (dBuV)	Correct Factor (dB/m)	Result (dBuV/m)	Limit (dBuV/m)	Margin (dB)	Remark
1	5443.200	51.55	6.15	57.70	74.00	-16.30	peak
2	5460.000	49.70	6.16	55.86	74.00	-18.14	peak
3	5465.600	52.92	6.16	59.08	68.20	-9.12	peak
4	5470.000	50.67	6.18	56.85	68.20	-11.35	peak
5	5584.000	103.34	6.43	109.77	68.20	41.57	peak
6	5725.000	55.37	6.81	62.18	68.20	-6.02	peak
7	5730.400	58.62	6.82	65.44	68.20	-2.76	peak

Note:1.Result (dBuV/m) = Correct Factor (dB/m) + Reading(dBuV).

2.Correction factor (dB/m) = Antenna Factor (dB/m) + Cable loss (dB) – Pre-Amplifier gain (dB).

3.When the peak results are less than average limit, so not need to evaluate the average.

Standard:	FCC Part 15.407	Test Distance:	3 m
Test item:	Band edge		
Frequency:	5690 MHz		
Mode:	Mode 10		
Ant.Polar.:	Horizontal		

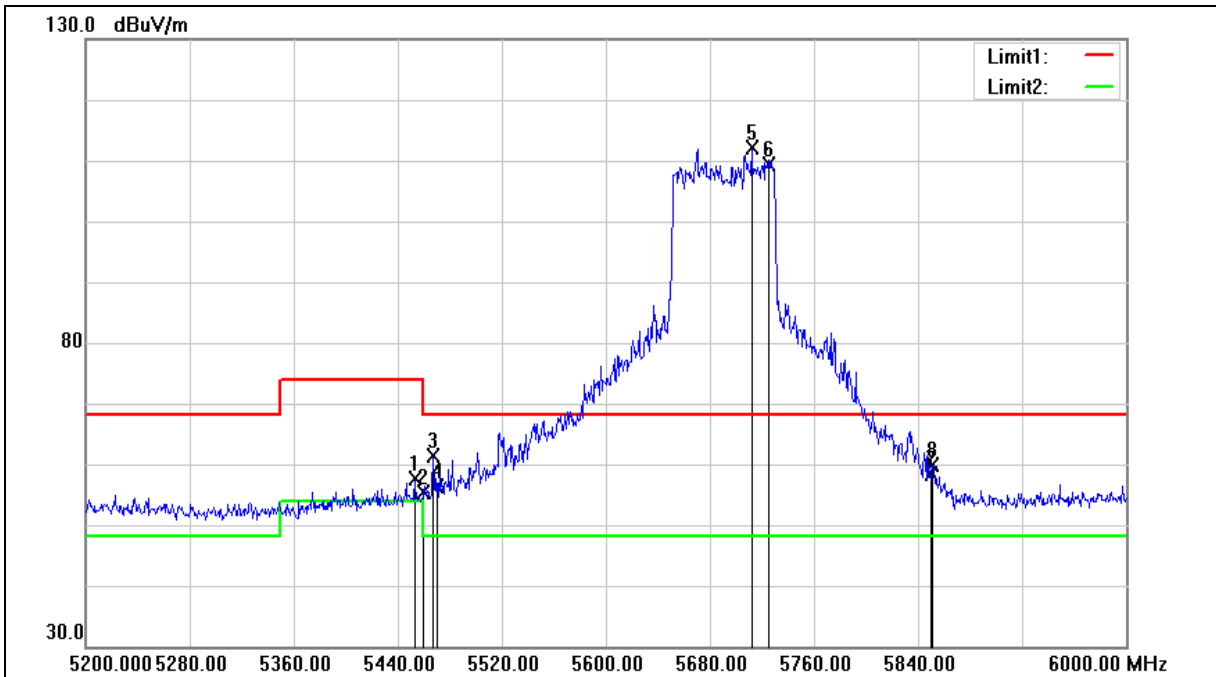

Standard:	FCC Part 15.407	Test Distance:	3 m
Test item:	Band edge		
Frequency:	5690 MHz		
Mode:	Mode 10		
Ant.Polar.:	Horizontal		

No.	Frequency (MHz)	Reading (dBuV)	Correct Factor (dB/m)	Result (dBuV/m)	Limit (dBuV/m)	Margin (dB)	Remark
1	5452.800	51.41	6.12	57.53	74.00	-16.47	peak
2	5460.000	49.33	6.14	55.47	74.00	-18.53	peak
3	5467.200	55.33	6.14	61.47	68.20	-6.73	peak
4	5470.000	50.24	6.15	56.39	68.20	-11.81	peak
5	5712.000	105.32	6.72	112.04	68.20	43.84	peak
6	5725.000	102.63	6.76	109.39	68.20	41.19	peak
7	5850.000	51.25	7.05	58.30	68.20	-9.90	peak
8	5851.200	52.87	7.05	59.92	68.20	-8.28	peak

Note:1.Result (dBuV/m) = Correct Factor (dB/m) + Reading(dBuV).

2.Correction factor (dB/m) = Antenna Factor (dB/m) + Cable loss (dB) – Pre-Amplifier gain (dB).

3.When the peak results are less than average limit, so not need to evaluate the average.

Standard:	FCC Part 15.407	Test Distance:	3 m
Test item:	Band edge		
Frequency:	5690 MHz		
Mode:	Mode 10		
Ant.Polar.:	Vertical		

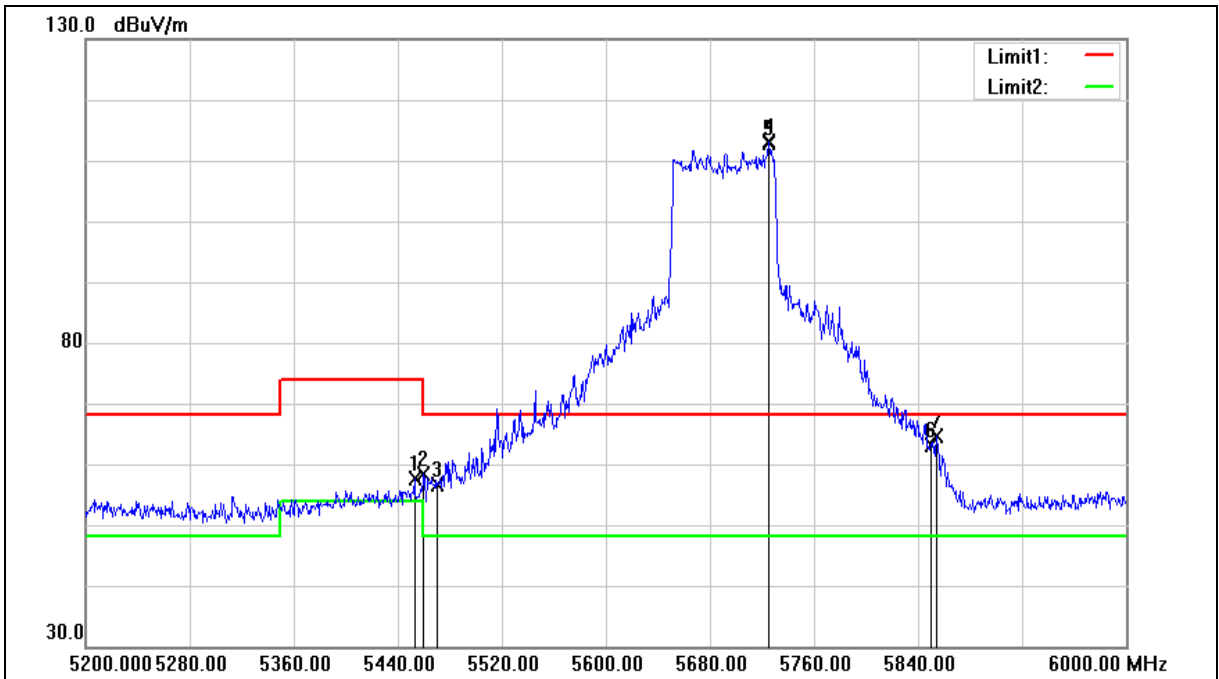

Standard:	FCC Part 15.407	Test Distance:	3 m
Test item:	Band edge		
Frequency:	5690 MHz		
Mode:	Mode 10		
Ant.Polar.:	Vertical		

No.	Frequency (MHz)	Reading (dBuV)	Correct Factor (dB/m)	Result (dBuV/m)	Limit (dBuV/m)	Margin (dB)	Remark
1	5452.800	51.50	6.12	57.62	74.00	-16.38	peak
2	5460.000	52.25	6.14	58.39	74.00	-15.61	peak
3	5470.000	50.59	6.15	56.74	68.20	-11.46	peak
4	5724.800	106.31	6.75	113.06	68.20	44.86	peak
5	5725.000	106.23	6.76	112.99	68.20	44.79	peak
6	5850.000	56.16	7.05	63.21	68.20	-4.99	peak
7	5854.400	57.55	7.07	64.62	68.20	-3.58	peak

Note:1.Result (dBuV/m) = Correct Factor (dB/m) + Reading(dBuV).

2.Correction factor (dB/m) = Antenna Factor (dB/m) + Cable loss (dB) – Pre-Amplifier gain (dB).

3.When the peak results are less than average limit, so not need to evaluate the average.

Average

Standard:	FCC Part 15.407	Test Distance:	3 m
Test item:	Band edge		
Frequency:	5260 MHz		
Mode:	Mode 2		
Ant.Polar.:	Horizontal		

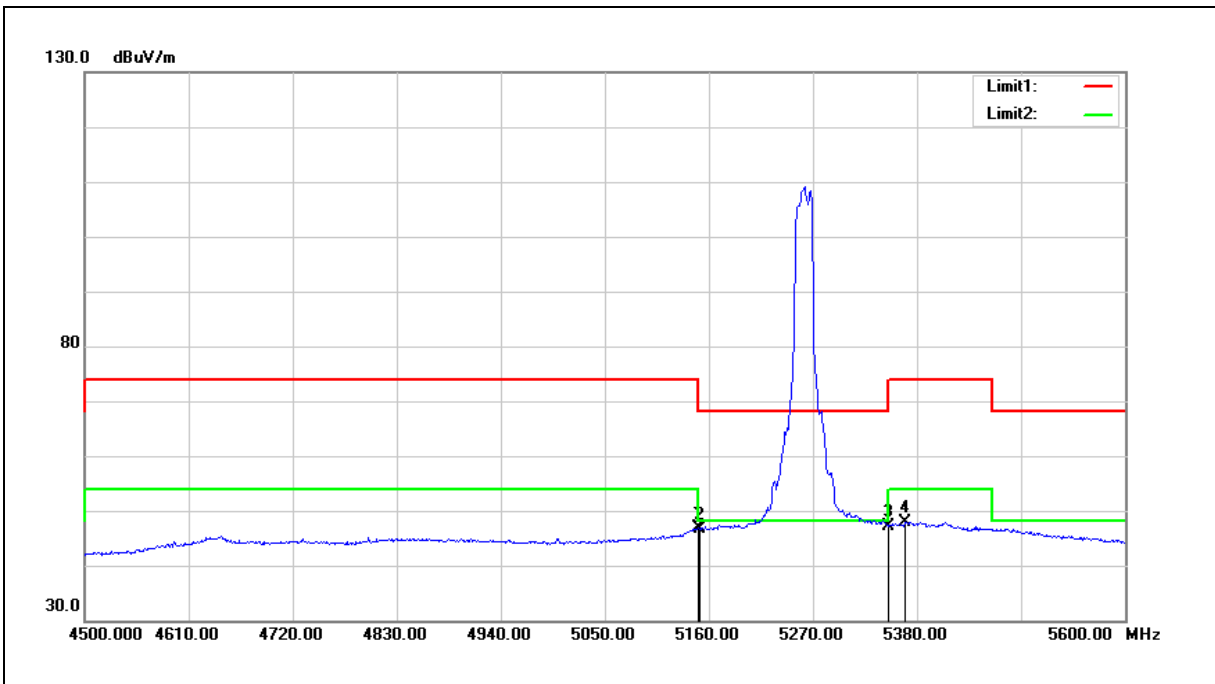

No.	Frequency (MHz)	Reading (dBuV)	Correct Factor (dB/m)	Result (dBuV/m)	Limit (dBuV/m)	Margin (dB)	Remark
1	5149.000	41.13	5.76	46.89	54.00	-7.11	AVG
2	5150.000	40.84	5.75	46.59	54.00	-7.41	AVG
3	5350.000	41.12	6.00	47.12	54.00	-6.88	AVG
4	5367.900	41.84	6.02	47.86	54.00	-6.14	AVG

- Note:1.Result (dBuV/m) = Correct Factor (dB/m) + Reading(dBuV).
 2.Correction factor (dB/m) = Antenna Factor (dB/m) + Cable loss (dB) – Pre-Amplifier gain (dB).
 3.When the peak results are less than average limit, so not need to evaluate the average.

Standard:	FCC Part 15.407	Test Distance:	3 m
Test item:	Band edge		
Frequency:	5260 MHz		
Mode:	Mode 2		
Ant.Polar.:	Vertical		

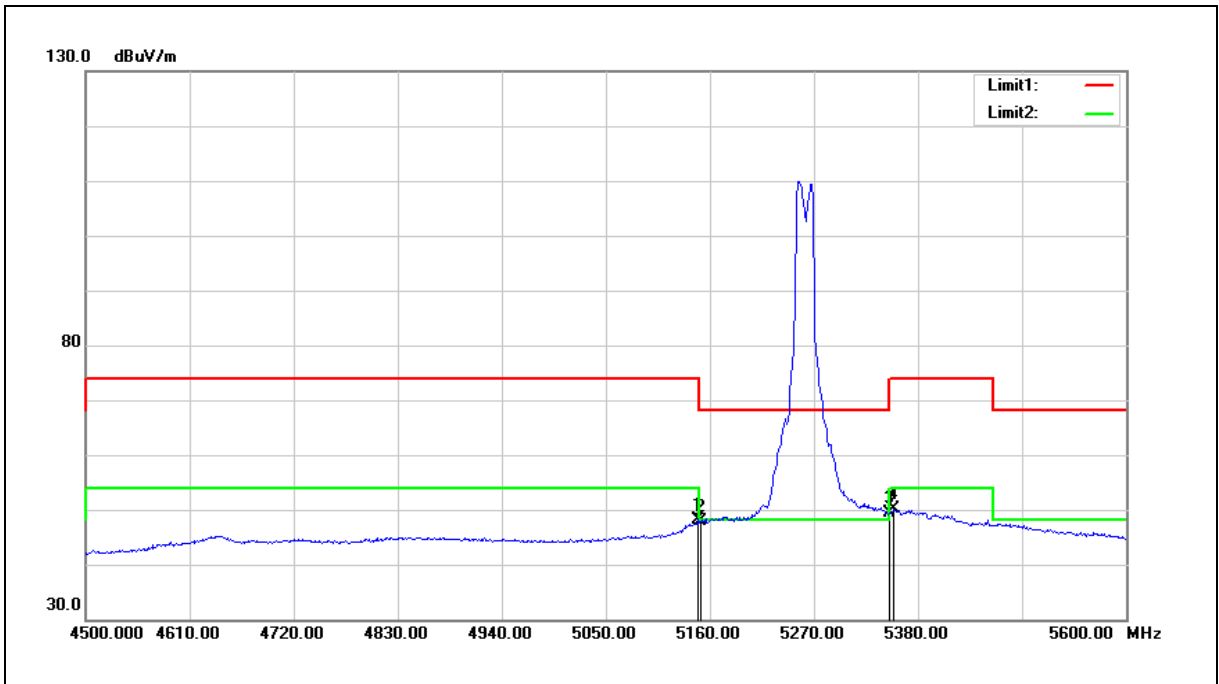

No.	Frequency (MHz)	Reading (dBuV)	Correct Factor (dB/m)	Result (dBuV/m)	Limit (dBuV/m)	Margin (dB)	Remark
1	5147.900	42.49	5.76	48.25	54.00	-5.75	AVG
2	5150.000	42.21	5.75	47.96	54.00	-6.04	AVG
3	5350.000	43.38	6.00	49.38	54.00	-4.62	AVG
4	5354.700	44.01	6.00	50.01	54.00	-3.99	AVG

Note:1.Result (dBuV/m) = Correct Factor (dB/m) + Reading(dBuV).

2.Correction factor (dB/m) = Antenna Factor (dB/m) + Cable loss (dB) – Pre-Amplifier gain (dB).

3.When the peak results are less than average limit, so not need to evaluate the average.

Standard:	FCC Part 15.407	Test Distance:	3 m
Test item:	Band edge		
Frequency:	5280 MHz		
Mode:	Mode 2		
Ant.Polar.:	Horizontal		

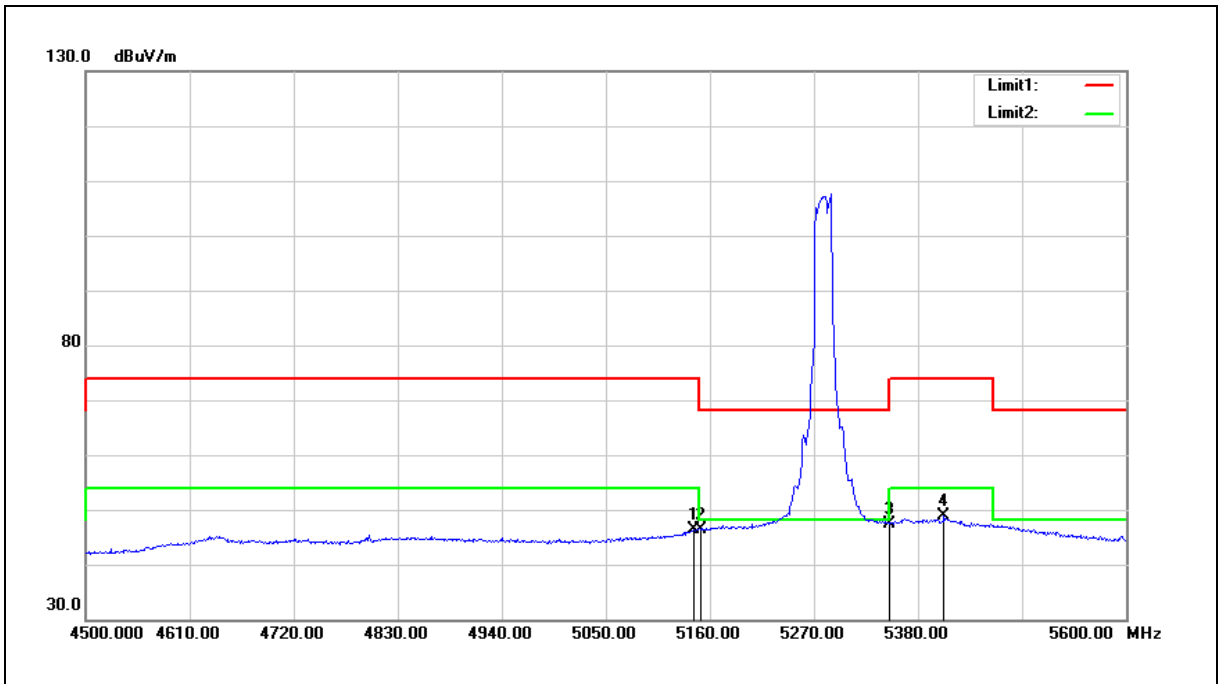

No.	Frequency (MHz)	Reading (dBuV)	Correct Factor (dB/m)	Result (dBuV/m)	Limit (dBuV/m)	Margin (dB)	Remark
1	5142.400	40.73	5.75	46.48	54.00	-7.52	AVG
2	5150.000	40.59	5.75	46.34	54.00	-7.66	AVG
3	5350.000	41.40	6.00	47.40	54.00	-6.60	AVG
4	5407.500	42.69	6.08	48.77	54.00	-5.23	AVG

Note:1.Result (dBuV/m) = Correct Factor (dB/m) + Reading(dBuV).

2.Correction factor (dB/m) = Antenna Factor (dB/m) + Cable loss (dB) – Pre-Amplifier gain (dB).

3.When the peak results are less than average limit, so not need to evaluate the average.

Standard:	FCC Part 15.407	Test Distance:	3 m
Test item:	Band edge		
Frequency:	5280 MHz		
Mode:	Mode 2		
Ant.Polar.:	Vertical		

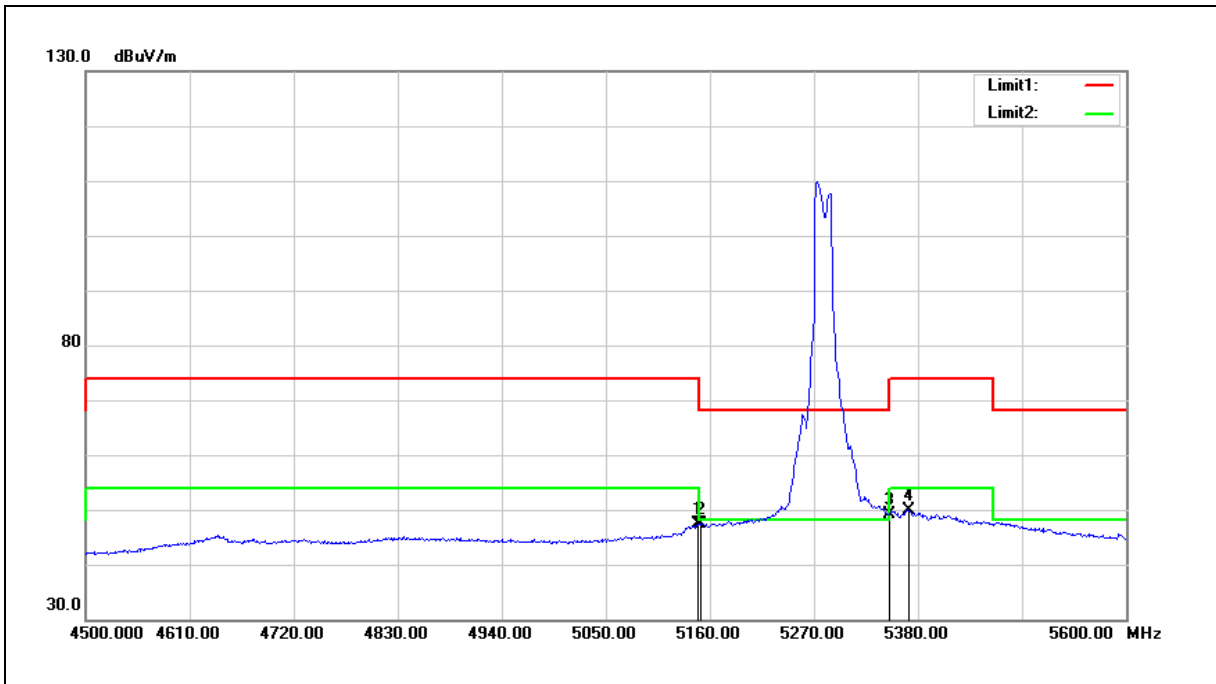

No.	Frequency (MHz)	Reading (dBuV)	Correct Factor (dB/m)	Result (dBuV/m)	Limit (dBuV/m)	Margin (dB)	Remark
1	5147.900	41.61	5.76	47.37	54.00	-6.63	AVG
2	5150.000	41.62	5.75	47.37	54.00	-6.63	AVG
3	5350.000	43.19	6.00	49.19	54.00	-4.81	AVG
4	5370.100	43.84	6.03	49.87	54.00	-4.13	AVG

Note:1.Result (dBuV/m) = Correct Factor (dB/m) + Reading(dBuV).

2.Correction factor (dB/m) = Antenna Factor (dB/m) + Cable loss (dB) – Pre-Amplifier gain (dB).

3.When the peak results are less than average limit, so not need to evaluate the average.

Standard:	FCC Part 15.407	Test Distance:	3 m
Test item:	Band edge		
Frequency:	5320 MHz		
Mode:	Mode 2		
Ant.Polar.:	Horizontal		

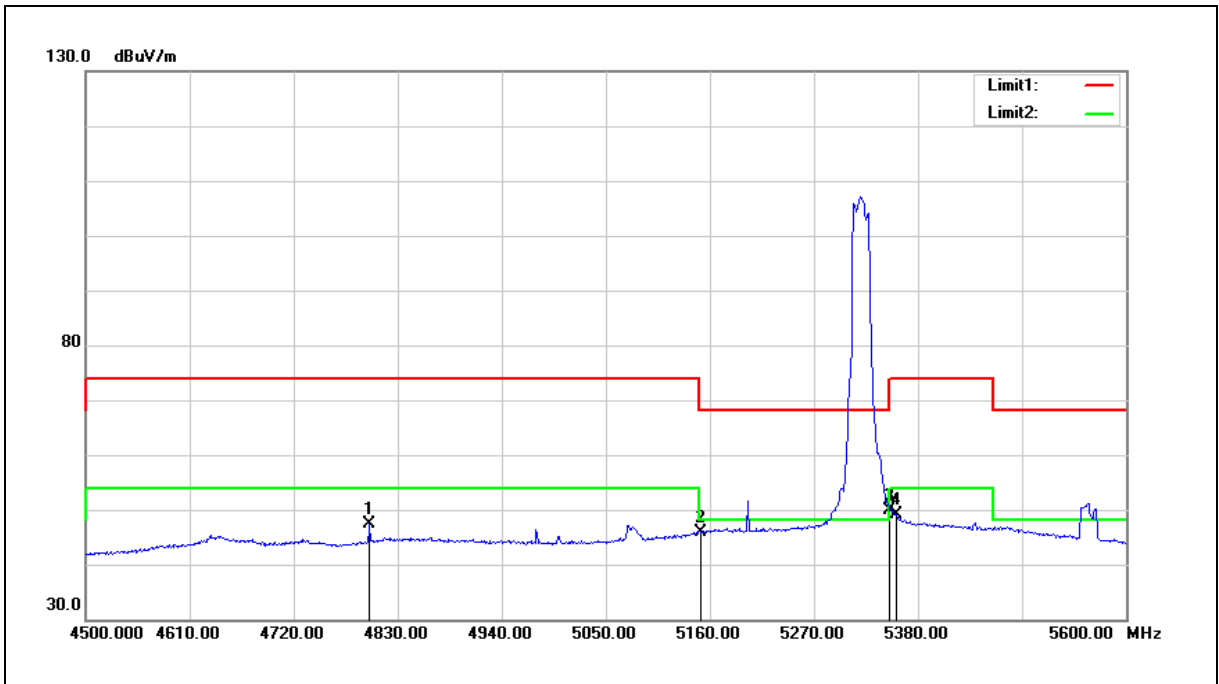

No.	Frequency (MHz)	Reading (dBuV)	Correct Factor (dB/m)	Result (dBuV/m)	Limit (dBuV/m)	Margin (dB)	Remark
1	4800.300	42.31	5.02	47.33	54.00	-6.67	AVG
2	5150.000	40.17	5.75	45.92	54.00	-8.08	AVG
3	5350.000	43.94	6.00	49.94	54.00	-4.06	AVG
4	5356.900	43.16	6.01	49.17	54.00	-4.83	AVG

Note:1.Result (dBuV/m) = Correct Factor (dB/m) + Reading(dBuV).

2.Correction factor (dB/m) = Antenna Factor (dB/m) + Cable loss (dB) – Pre-Amplifier gain (dB).

3.When the peak results are less than average limit, so not need to evaluate the average.

Standard:	FCC Part 15.407	Test Distance:	3 m
Test item:	Band edge		
Frequency:	5320 MHz		
Mode:	Mode 2		
Ant.Polar.:	Vertical		

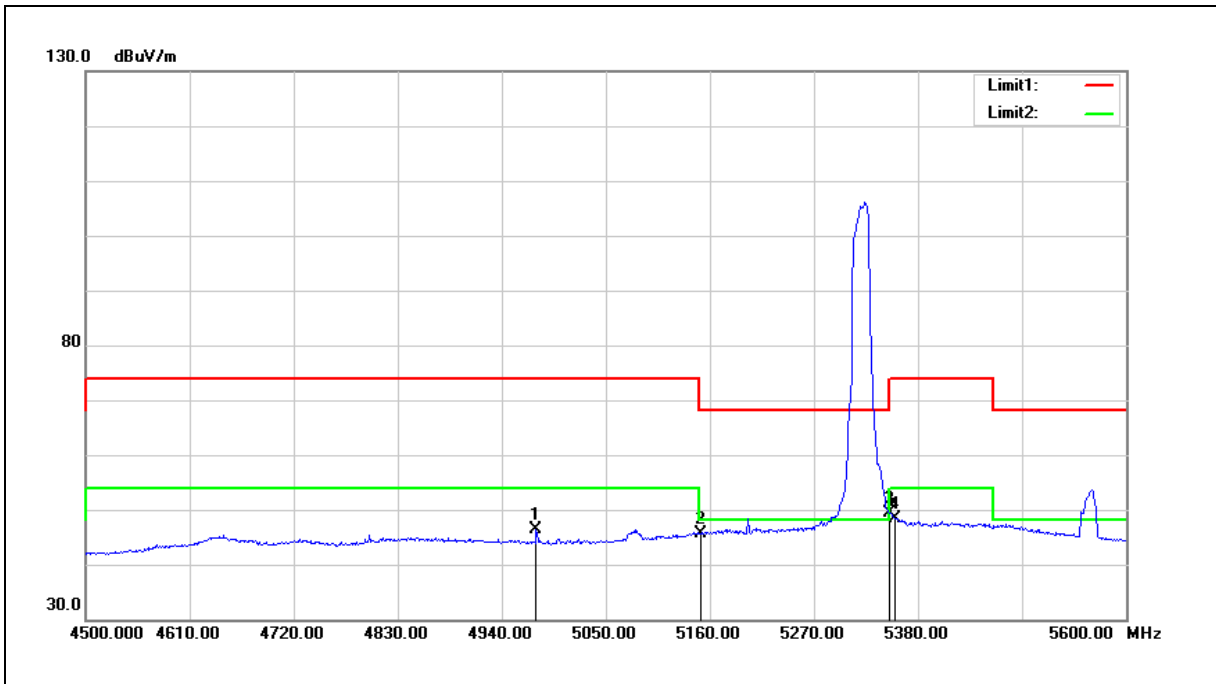

No.	Frequency (MHz)	Reading (dBuV)	Correct Factor (dB/m)	Result (dBuV/m)	Limit (dBuV/m)	Margin (dB)	Remark
1	4976.300	40.84	5.50	46.34	54.00	-7.66	AVG
2	5150.000	39.99	5.75	45.74	54.00	-8.26	AVG
3	5350.000	43.31	6.00	49.31	54.00	-4.69	AVG
4	5355.800	42.43	6.00	48.43	54.00	-5.57	AVG

Note:1.Result (dBuV/m) = Correct Factor (dB/m) + Reading(dBuV).

2.Correction factor (dB/m) = Antenna Factor (dB/m) + Cable loss (dB) – Pre-Amplifier gain (dB).

3.When the peak results are less than average limit, so not need to evaluate the average.

Standard:	FCC Part 15.407	Test Distance:	3 m
Test item:	Band edge		
Frequency:	5500 MHz		
Mode:	Mode 2		
Ant.Polar.:	Horizontal		

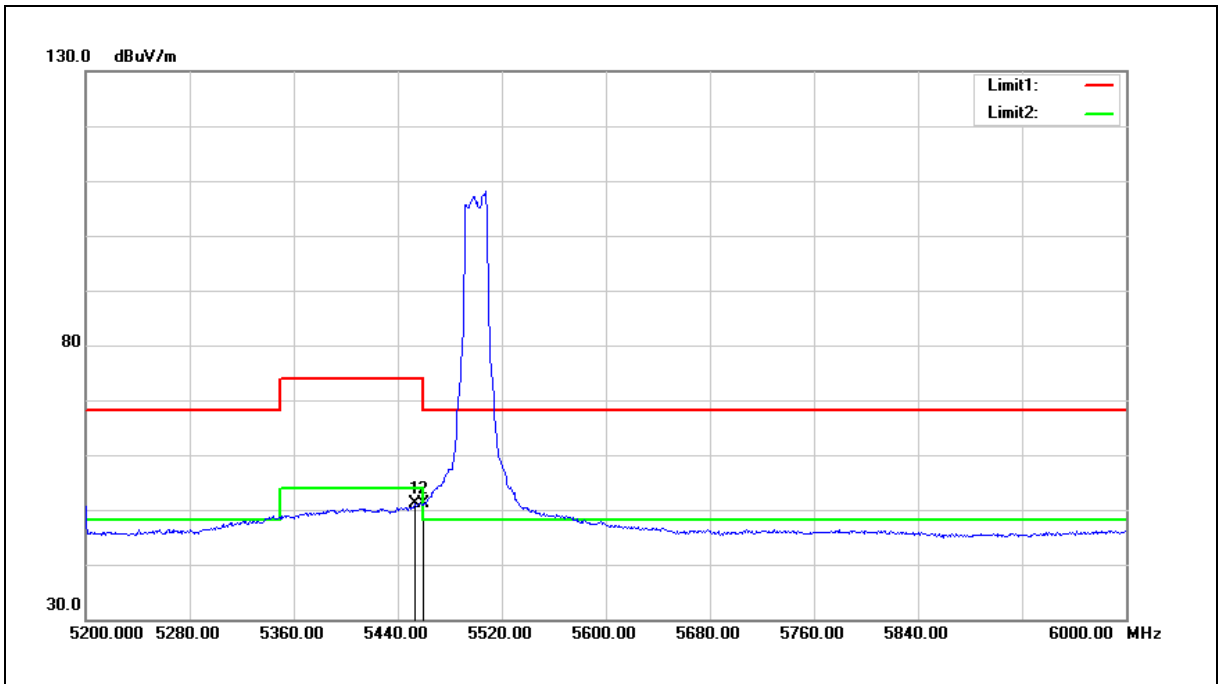

No.	Frequency (MHz)	Reading (dBuV)	Correct Factor (dB/m)	Result (dBuV/m)	Limit (dBuV/m)	Margin (dB)	Remark
1	5453.600	44.90	6.12	51.02	54.00	-2.98	AVG
2	5460.000	45.03	6.14	51.17	54.00	-2.83	AVG

Note:1.Result (dBuV/m) = Correct Factor (dB/m) + Reading(dBuV).

2.Correction factor (dB/m) = Antenna Factor (dB/m) + Cable loss (dB) – Pre-Amplifier gain (dB).

3.When the peak results are less than average limit, so not need to evaluate the average.

Standard:	FCC Part 15.407	Test Distance:	3 m
Test item:	Band edge		
Frequency:	5500 MHz		
Mode:	Mode 2		
Ant.Polar.:	Vertical		

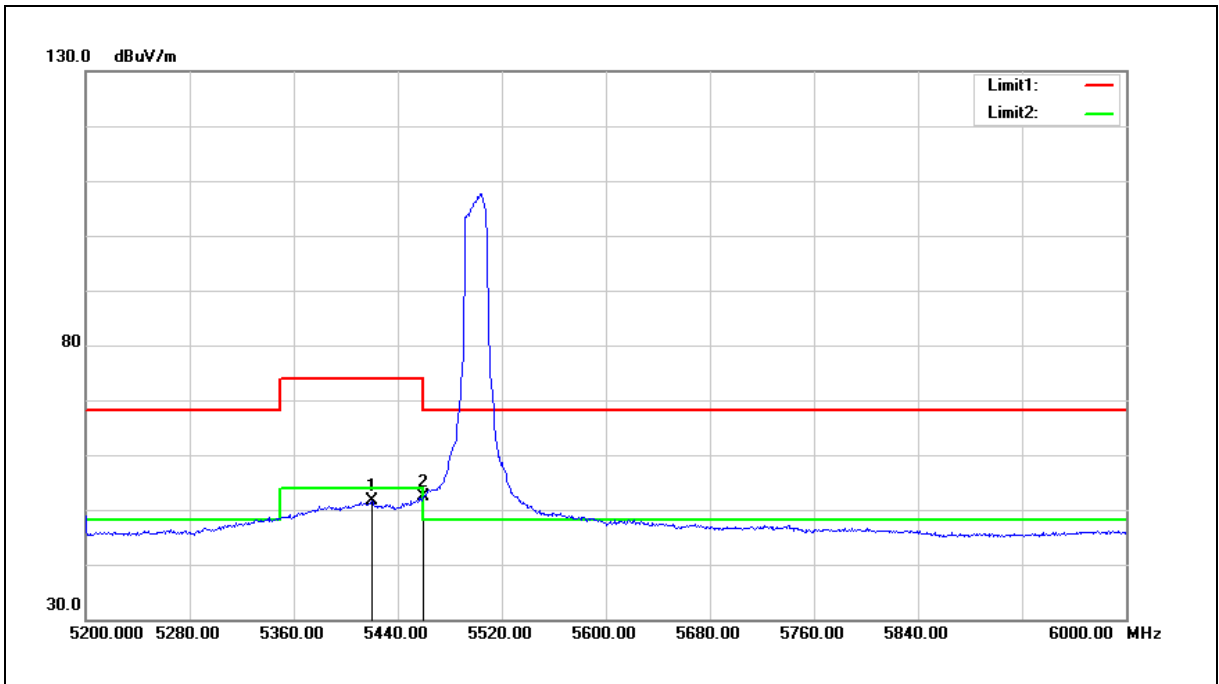

No.	Frequency (MHz)	Reading (dBuV)	Correct Factor (dB/m)	Result (dBuV/m)	Limit (dBuV/m)	Margin (dB)	Remark
1	5420.000	45.47	6.10	51.57	54.00	-2.43	AVG
2	5460.000	46.17	6.14	52.31	54.00	-1.69	AVG

Note:1.Result (dBuV/m) = Correct Factor (dB/m) + Reading(dBuV).

2.Correction factor (dB/m) = Antenna Factor (dB/m) + Cable loss (dB) – Pre-Amplifier gain (dB).

3.When the peak results are less than average limit, so not need to evaluate the average.

Standard:	FCC Part 15.407	Test Distance:	3 m
Test item:	Band edge		
Frequency:	5560 MHz		
Mode:	Mode 2		
Ant.Polar.:	Horizontal		

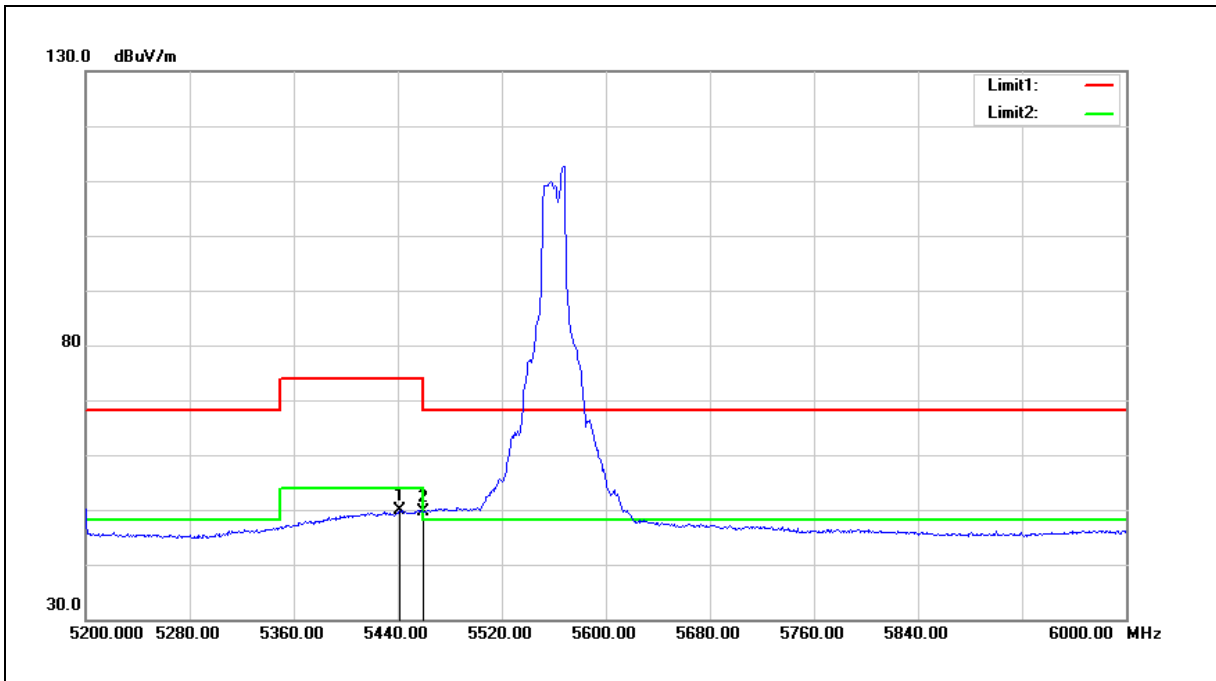

No.	Frequency (MHz)	Reading (dBuV)	Correct Factor (dB/m)	Result (dBuV/m)	Limit (dBuV/m)	Margin (dB)	Remark
1	5441.600	43.82	6.12	49.94	54.00	-4.06	AVG
2	5460.000	43.54	6.14	49.68	54.00	-4.32	AVG

- Note:1.Result (dBuV/m) = Correct Factor (dB/m) + Reading(dBuV).
- 2.Correction factor (dB/m) = Antenna Factor (dB/m) + Cable loss (dB) – Pre-Amplifier gain (dB).
- 3.When the peak results are less than average limit, so not need to evaluate the average.

Standard:	FCC Part 15.407	Test Distance:	3 m
Test item:	Band edge		
Frequency:	5560 MHz		
Mode:	Mode 2		
Ant.Polar.:	Vertical		

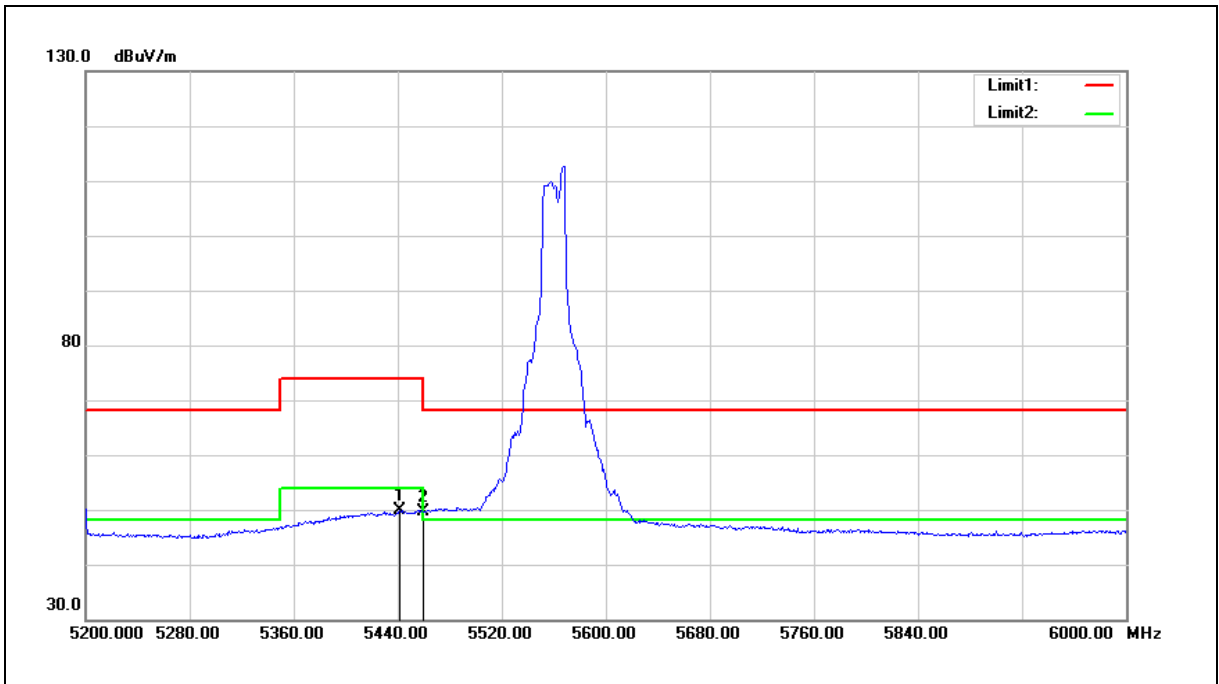

No.	Frequency (MHz)	Reading (dBuV)	Correct Factor (dB/m)	Result (dBuV/m)	Limit (dBuV/m)	Margin (dB)	Remark
1	5441.600	43.82	6.12	49.94	54.00	-4.06	AVG
2	5460.000	43.54	6.14	49.68	54.00	-4.32	AVG

Note:1.Result (dBuV/m) = Correct Factor (dB/m) + Reading(dBuV).

2.Correction factor (dB/m) = Antenna Factor (dB/m) + Cable loss (dB) – Pre-Amplifier gain (dB).

3.When the peak results are less than average limit, so not need to evaluate the average.

Standard:	FCC Part 15.407	Test Distance:	3 m
Test item:	Band edge		
Frequency:	5700 MHz		
Mode:	Mode 2		
Ant.Polar.:	Horizontal		

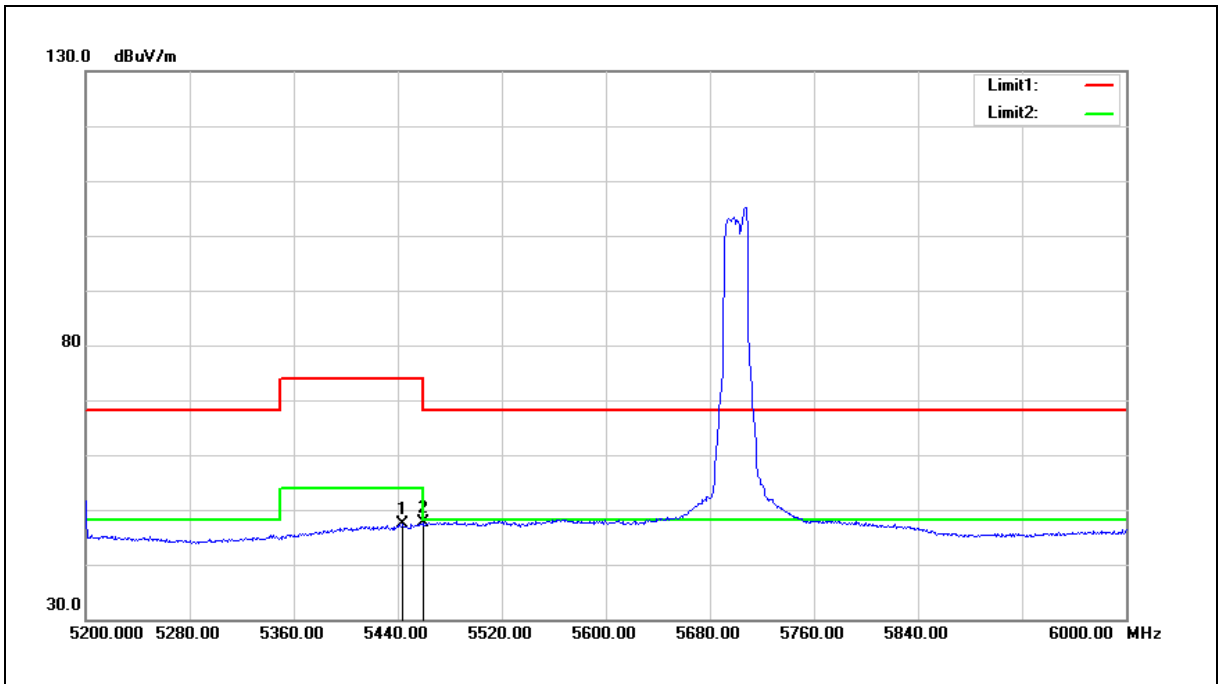

No.	Frequency (MHz)	Reading (dBuV)	Correct Factor (dB/m)	Result (dBuV/m)	Limit (dBuV/m)	Margin (dB)	Remark
1	5444.000	41.28	6.13	47.41	54.00	-6.59	AVG
2	5460.000	41.56	6.14	47.70	54.00	-6.30	AVG

Note:1.Result (dBuV/m) = Correct Factor (dB/m) + Reading(dBuV).

2.Correction factor (dB/m) = Antenna Factor (dB/m) + Cable loss (dB) – Pre-Amplifier gain (dB).

3.When the peak results are less than average limit, so not need to evaluate the average.

Standard:	FCC Part 15.407	Test Distance:	3 m
Test item:	Band edge		
Frequency:	5700 MHz		
Mode:	Mode 2		
Ant.Polar.:	Vertical		

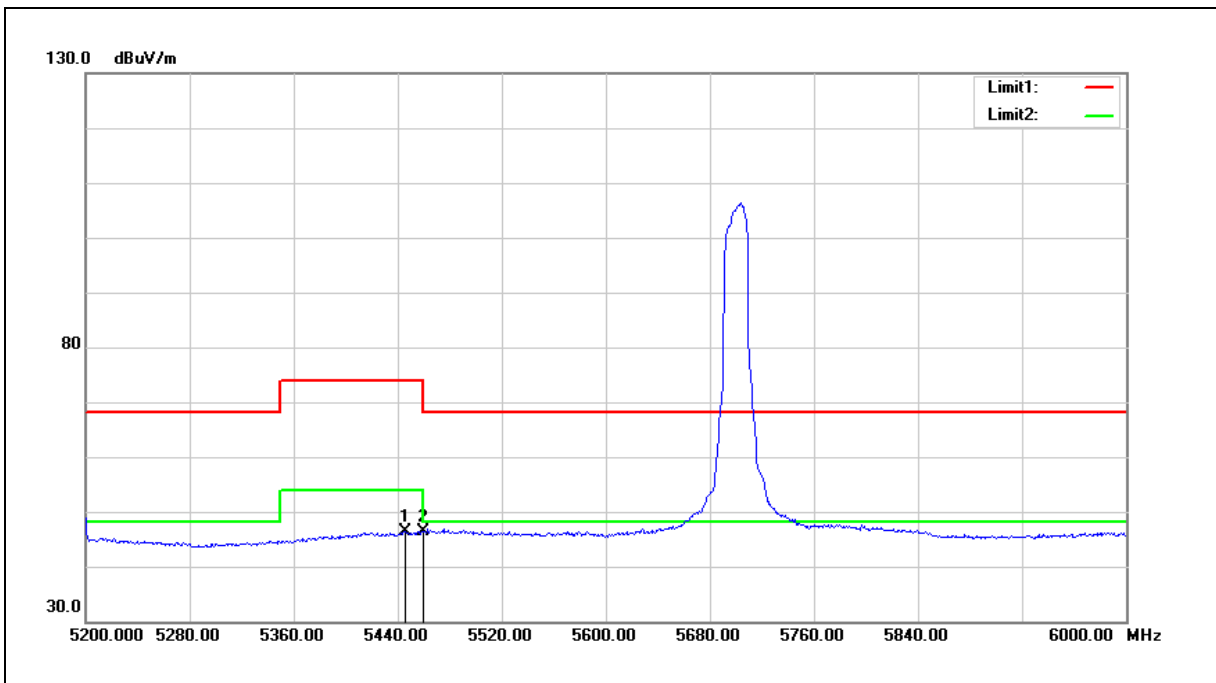

No.	Frequency (MHz)	Reading (dBuV)	Correct Factor (dB/m)	Result (dBuV/m)	Limit (dBuV/m)	Margin (dB)	Remark
1	5445.600	40.24	6.13	46.37	54.00	-7.63	AVG
2	5460.000	40.30	6.14	46.44	54.00	-7.56	AVG

Note:1.Result (dBuV/m) = Correct Factor (dB/m) + Reading(dBuV).

2.Correction factor (dB/m) = Antenna Factor (dB/m) + Cable loss (dB) – Pre-Amplifier gain (dB).

3.When the peak results are less than average limit, so not need to evaluate the average.

Standard:	FCC Part 15.407	Test Distance:	3 m
Test item:	Band edge		
Frequency:	5720 MHz		
Mode:	Mode 2		
Ant.Polar.:	Horizontal		

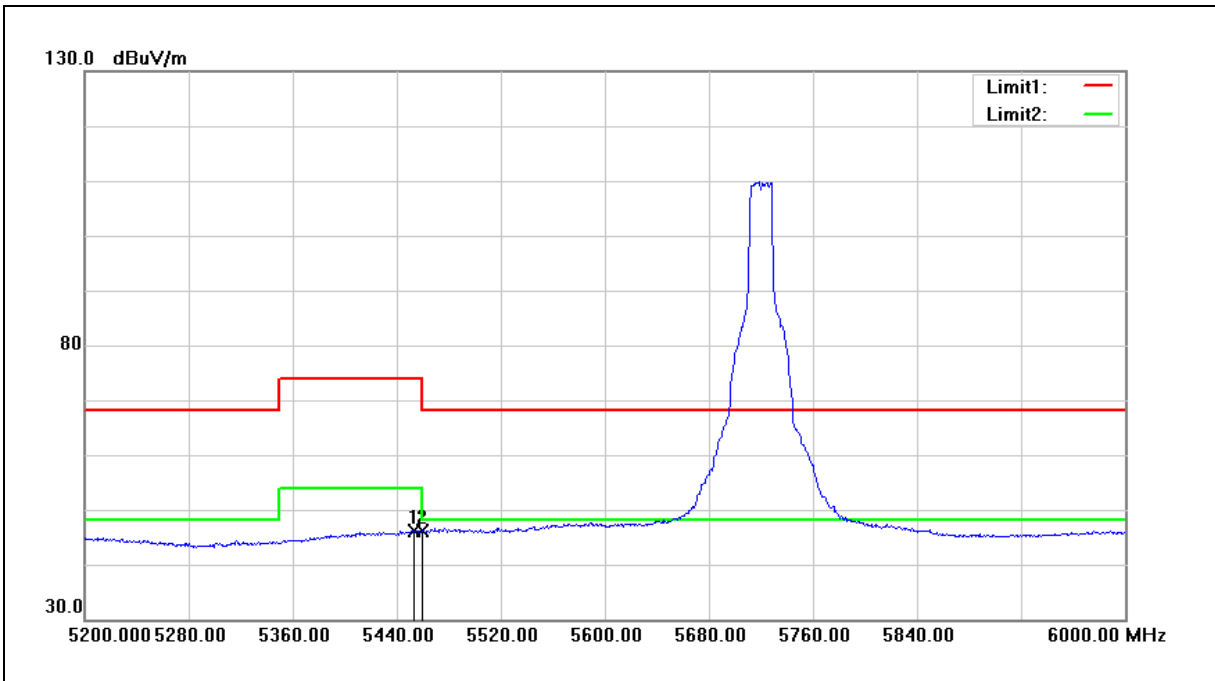

No.	Frequency (MHz)	Reading (dBuV)	Correct Factor (dB/m)	Result (dBuV/m)	Limit (dBuV/m)	Margin (dB)	Remark
1	5452.800	40.11	6.12	46.23	54.00	-7.77	AVG
2	5460.000	40.04	6.14	46.18	54.00	-7.82	AVG

- Note:1.Result (dBuV/m) = Correct Factor (dB/m) + Reading(dBuV).
 2.Correction factor (dB/m) = Antenna Factor (dB/m) + Cable loss (dB) – Pre-Amplifier gain (dB).
 3.When the peak results are less than average limit, so not need to evaluate the average.

Standard:	FCC Part 15.407	Test Distance:	3 m
Test item:	Band edge		
Frequency:	5720 MHz		
Mode:	Mode 2		
Ant.Polar.:	Vertical		

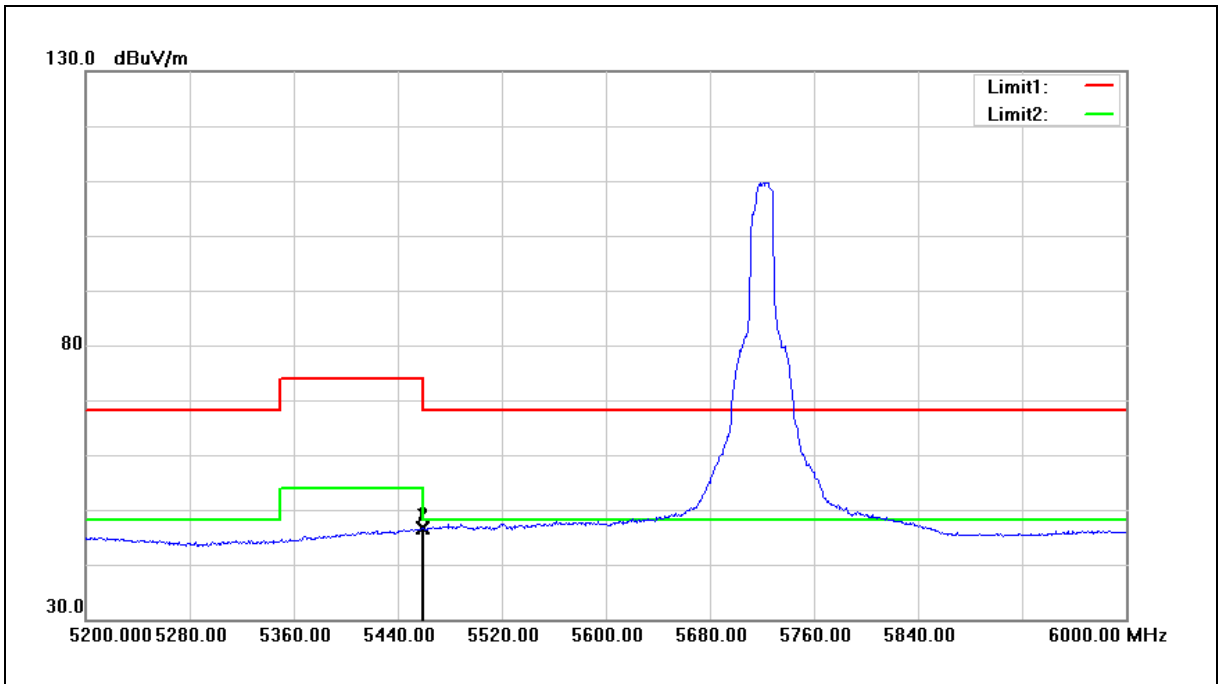

No.	Frequency (MHz)	Reading (dBuV)	Correct Factor (dB/m)	Result (dBuV/m)	Limit (dBuV/m)	Margin (dB)	Remark
1	5458.400	40.43	6.14	46.57	54.00	-7.43	AVG
2	5460.000	40.55	6.14	46.69	54.00	-7.31	AVG

Note:1.Result (dBuV/m) = Correct Factor (dB/m) + Reading(dBuV).

2.Correction factor (dB/m) = Antenna Factor (dB/m) + Cable loss (dB) – Pre-Amplifier gain (dB).

3.When the peak results are less than average limit, so not need to evaluate the average.

Standard:	FCC Part 15.407	Test Distance:	3 m
Test item:	Band edge		
Frequency:	5260 MHz		
Mode:	Mode 8		
Ant.Polar.:	Horizontal		

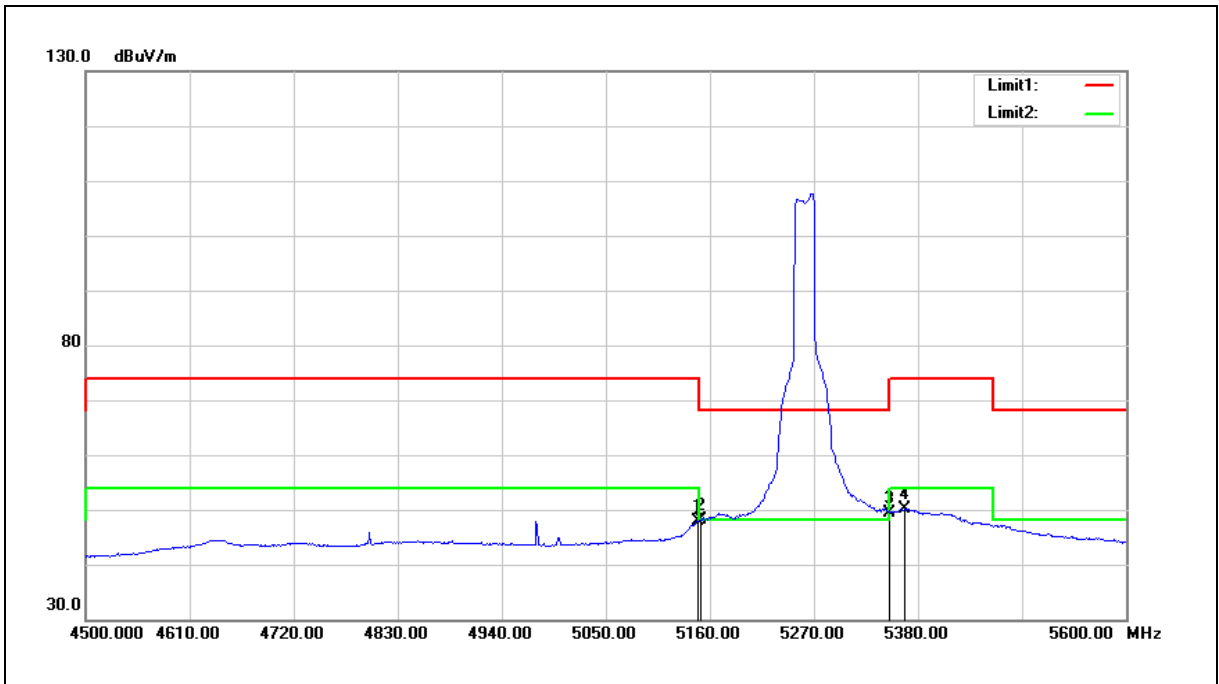

No.	Frequency (MHz)	Reading (dBuV)	Correct Factor (dB/m)	Result (dBuV/m)	Limit (dBuV/m)	Margin (dB)	Remark
1	5147.900	42.15	5.76	47.91	54.00	-6.09	AVG
2	5150.000	42.39	5.75	48.14	54.00	-5.86	AVG
3	5350.000	43.42	6.00	49.42	54.00	-4.58	AVG
4	5365.700	44.11	6.02	50.13	54.00	-3.87	AVG

Note:1.Result (dBuV/m) = Correct Factor (dB/m) + Reading(dBuV).

2.Correction factor (dB/m) = Antenna Factor (dB/m) + Cable loss (dB) – Pre-Amplifier gain (dB).

3.When the peak results are less than average limit, so not need to evaluate the average.

Standard:	FCC Part 15.407	Test Distance:	3 m
Test item:	Band edge		
Frequency:	5260 MHz		
Mode:	Mode 8		
Ant.Polar.:	Vertical		

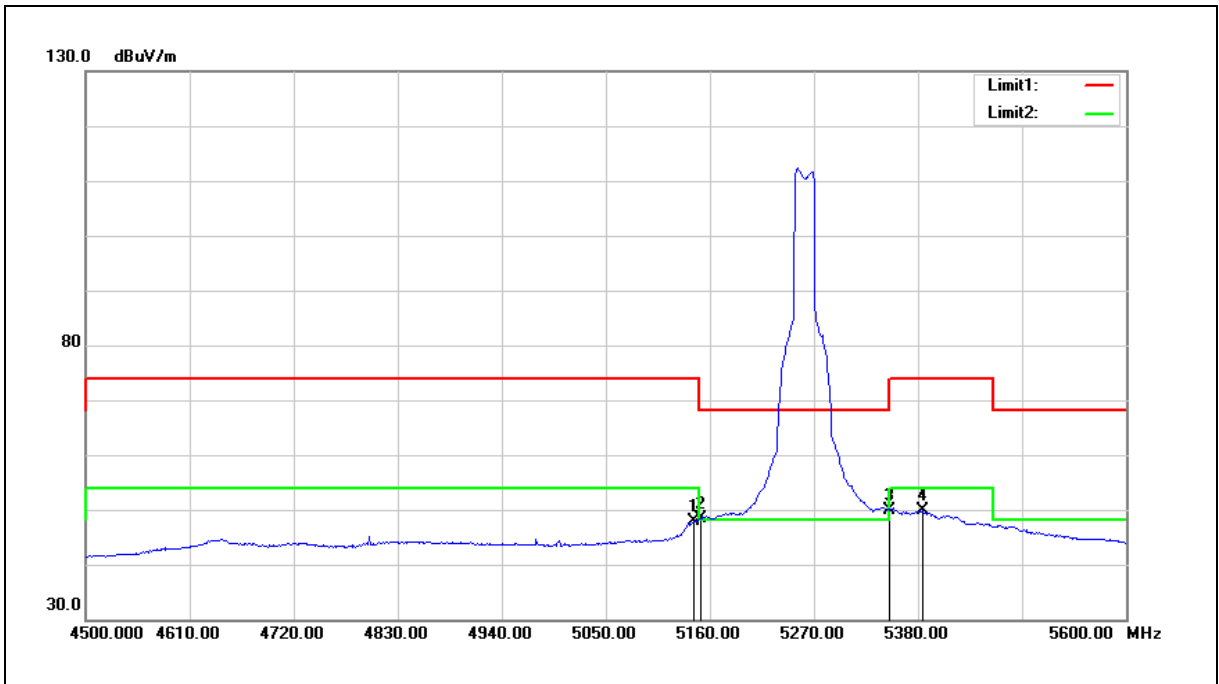

No.	Frequency (MHz)	Reading (dBuV)	Correct Factor (dB/m)	Result (dBuV/m)	Limit (dBuV/m)	Margin (dB)	Remark
1	5143.500	42.08	5.75	47.83	54.00	-6.17	AVG
2	5150.000	42.65	5.75	48.40	54.00	-5.60	AVG
3	5350.000	43.89	6.00	49.89	54.00	-4.11	AVG
4	5385.500	43.78	6.05	49.83	54.00	-4.17	AVG

Note:1.Result (dBuV/m) = Correct Factor (dB/m) + Reading(dBuV).

2.Correction factor (dB/m) = Antenna Factor (dB/m) + Cable loss (dB) – Pre-Amplifier gain (dB).

3.When the peak results are less than average limit, so not need to evaluate the average.

Standard:	FCC Part 15.407	Test Distance:	3 m
Test item:	Band edge		
Frequency:	5280 MHz		
Mode:	Mode 8		
Ant.Polar.:	Horizontal		

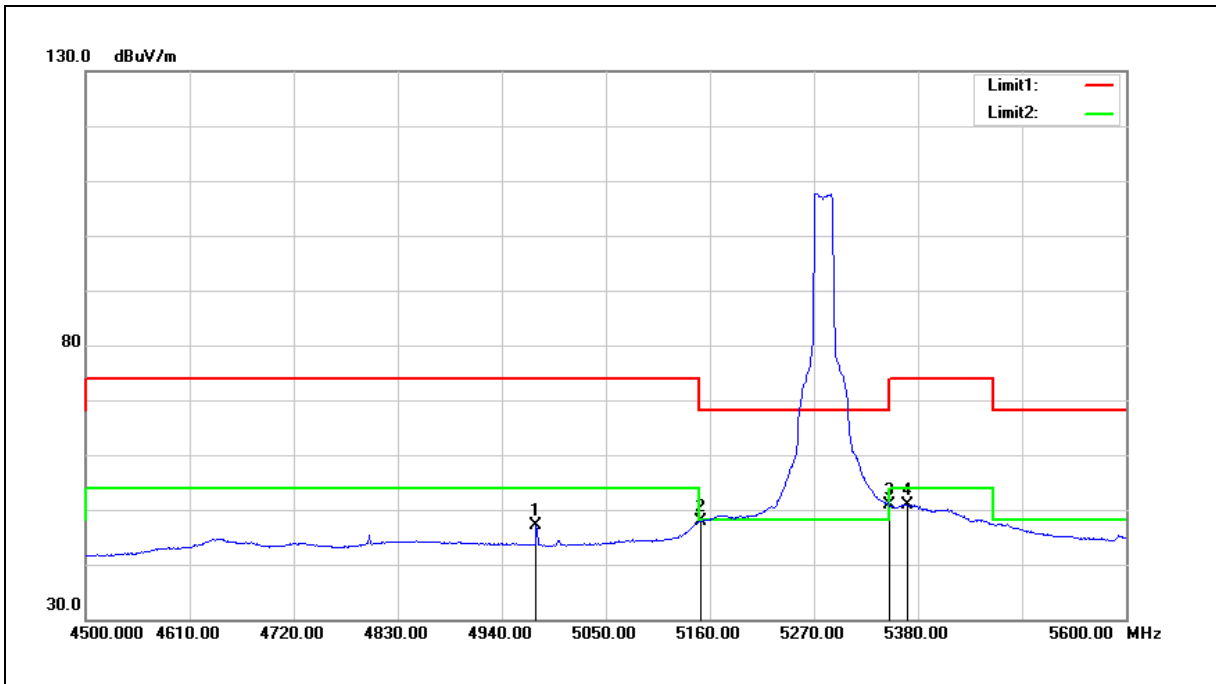

No.	Frequency (MHz)	Reading (dBuV)	Correct Factor (dB/m)	Result (dBuV/m)	Limit (dBuV/m)	Margin (dB)	Remark
1	4976.300	41.58	5.50	47.08	54.00	-6.92	AVG
2	5150.000	42.13	5.75	47.88	54.00	-6.12	AVG
3	5350.000	44.76	6.00	50.76	54.00	-3.24	AVG
4	5369.000	44.93	6.03	50.96	54.00	-3.04	AVG

Note:1.Result (dBuV/m) = Correct Factor (dB/m) + Reading(dBuV).

2.Correction factor (dB/m) = Antenna Factor (dB/m) + Cable loss (dB) – Pre-Amplifier gain (dB).

3.When the peak results are less than average limit, so not need to evaluate the average.

Standard:	FCC Part 15.407	Test Distance:	3 m
Test item:	Band edge		
Frequency:	5280 MHz		
Mode:	Mode 8		
Ant.Polar.:	Vertical		

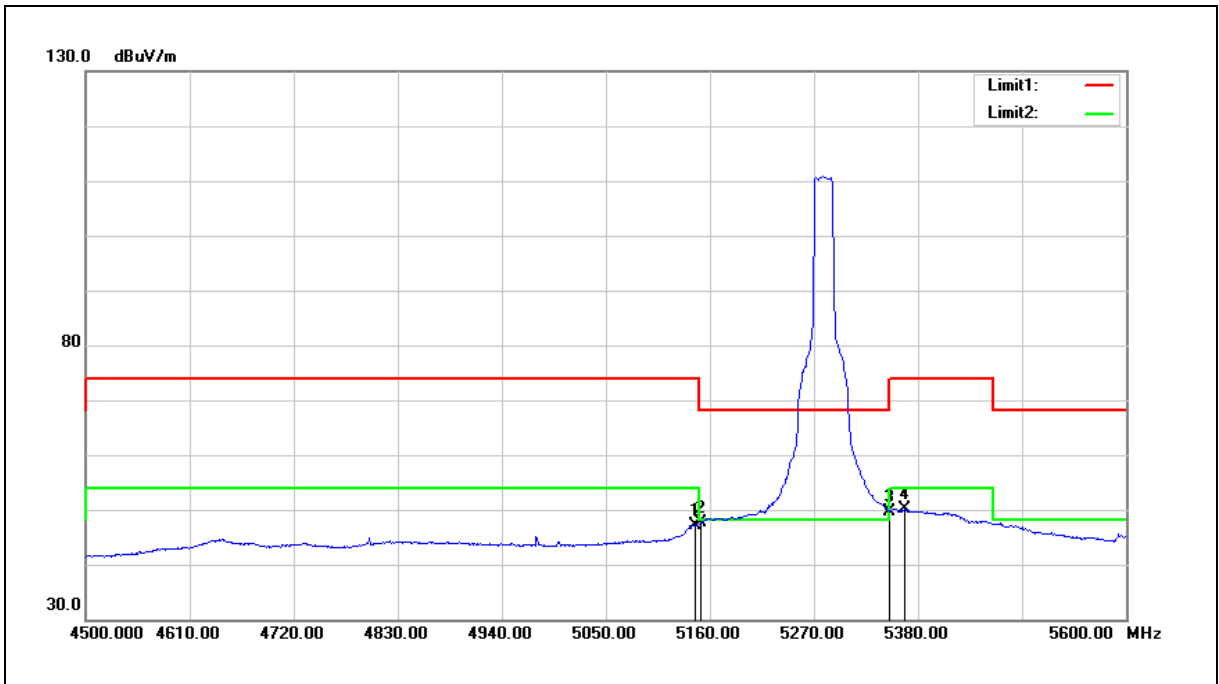

No.	Frequency (MHz)	Reading (dBuV)	Correct Factor (dB/m)	Result (dBuV/m)	Limit (dBuV/m)	Margin (dB)	Remark
1	5144.600	41.44	5.76	47.20	54.00	-6.80	AVG
2	5150.000	41.87	5.75	47.62	54.00	-6.38	AVG
3	5350.000	43.73	6.00	49.73	54.00	-4.27	AVG
4	5365.700	44.06	6.02	50.08	54.00	-3.92	AVG

Note:1.Result (dBuV/m) = Correct Factor (dB/m) + Reading(dBuV).

2.Correction factor (dB/m) = Antenna Factor (dB/m) + Cable loss (dB) – Pre-Amplifier gain (dB).

3.When the peak results are less than average limit, so not need to evaluate the average.

Standard:	FCC Part 15.407	Test Distance:	3 m
Test item:	Band edge		
Frequency:	5320 MHz		
Mode:	Mode 8		
Ant.Polar.:	Horizontal		

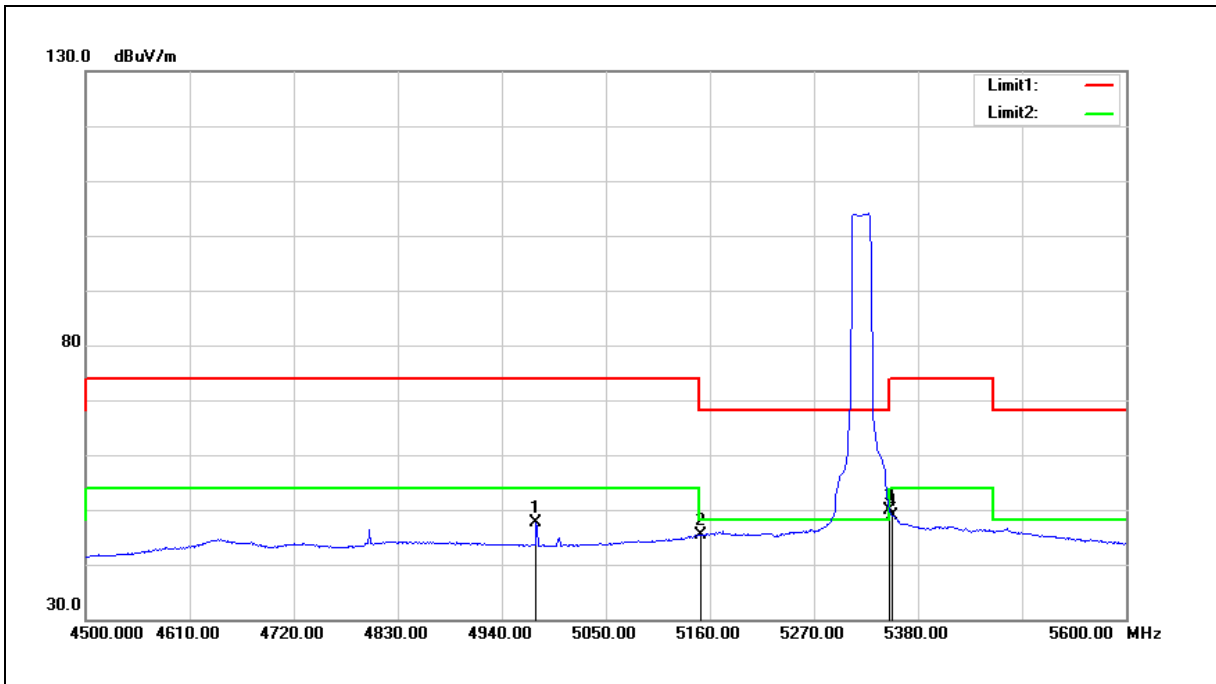

No.	Frequency (MHz)	Reading (dBuV)	Correct Factor (dB/m)	Result (dBuV/m)	Limit (dBuV/m)	Margin (dB)	Remark
1	4976.300	42.12	5.50	47.62	54.00	-6.38	AVG
2	5150.000	39.65	5.75	45.40	54.00	-8.60	AVG
3	5350.000	43.82	6.00	49.82	54.00	-4.18	AVG
4	5352.500	42.98	6.00	48.98	54.00	-5.02	AVG

Note:1.Result (dBuV/m) = Correct Factor (dB/m) + Reading(dBuV).

2.Correction factor (dB/m) = Antenna Factor (dB/m) + Cable loss (dB) – Pre-Amplifier gain (dB).

3.When the peak results are less than average limit, so not need to evaluate the average.

Standard:	FCC Part 15.407	Test Distance:	3 m
Test item:	Band edge		
Frequency:	5320 MHz		
Mode:	Mode 8		
Ant.Polar.:	Vertical		

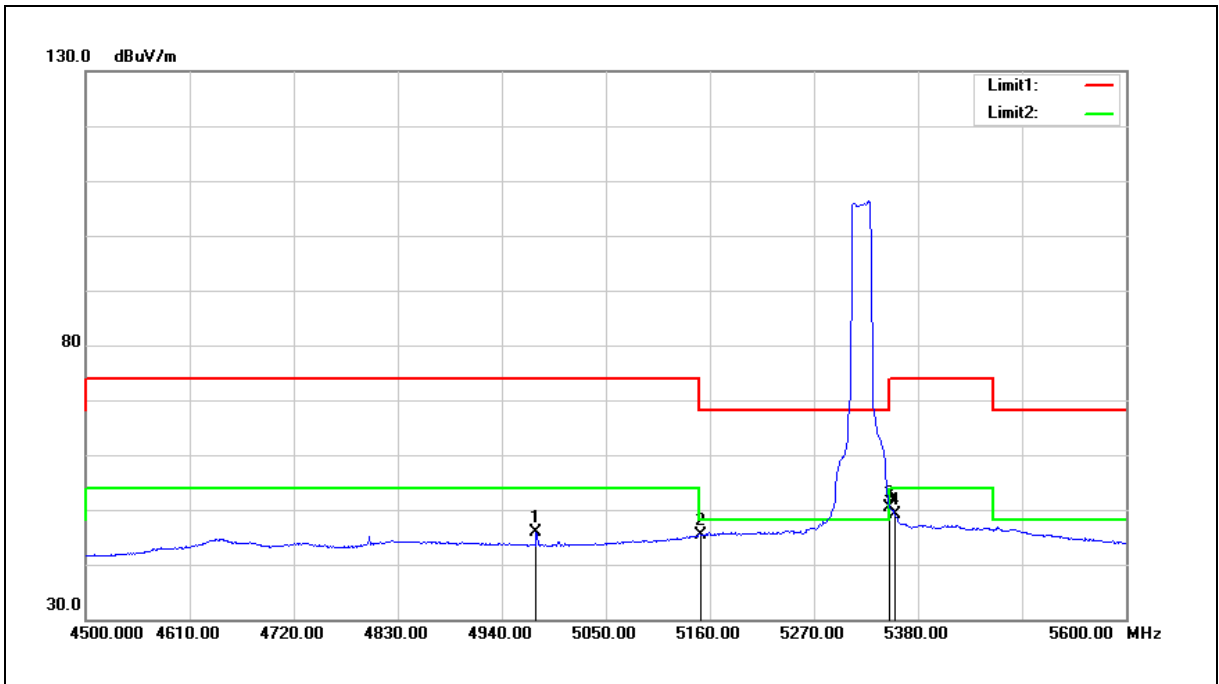

No.	Frequency (MHz)	Reading (dBuV)	Correct Factor (dB/m)	Result (dBuV/m)	Limit (dBuV/m)	Margin (dB)	Remark
1	4976.300	40.45	5.50	45.95	54.00	-8.05	AVG
2	5150.000	39.71	5.75	45.46	54.00	-8.54	AVG
3	5350.000	44.30	6.00	50.30	54.00	-3.70	AVG
4	5355.800	43.11	6.00	49.11	54.00	-4.89	AVG

Note:1.Result (dBuV/m) = Correct Factor (dB/m) + Reading(dBuV).

2.Correction factor (dB/m) = Antenna Factor (dB/m) + Cable loss (dB) – Pre-Amplifier gain (dB).

3.When the peak results are less than average limit, so not need to evaluate the average.

Standard:	FCC Part 15.407	Test Distance:	3 m
Test item:	Band edge		
Frequency:	5500 MHz		
Mode:	Mode 8		
Ant.Polar.:	Horizontal		

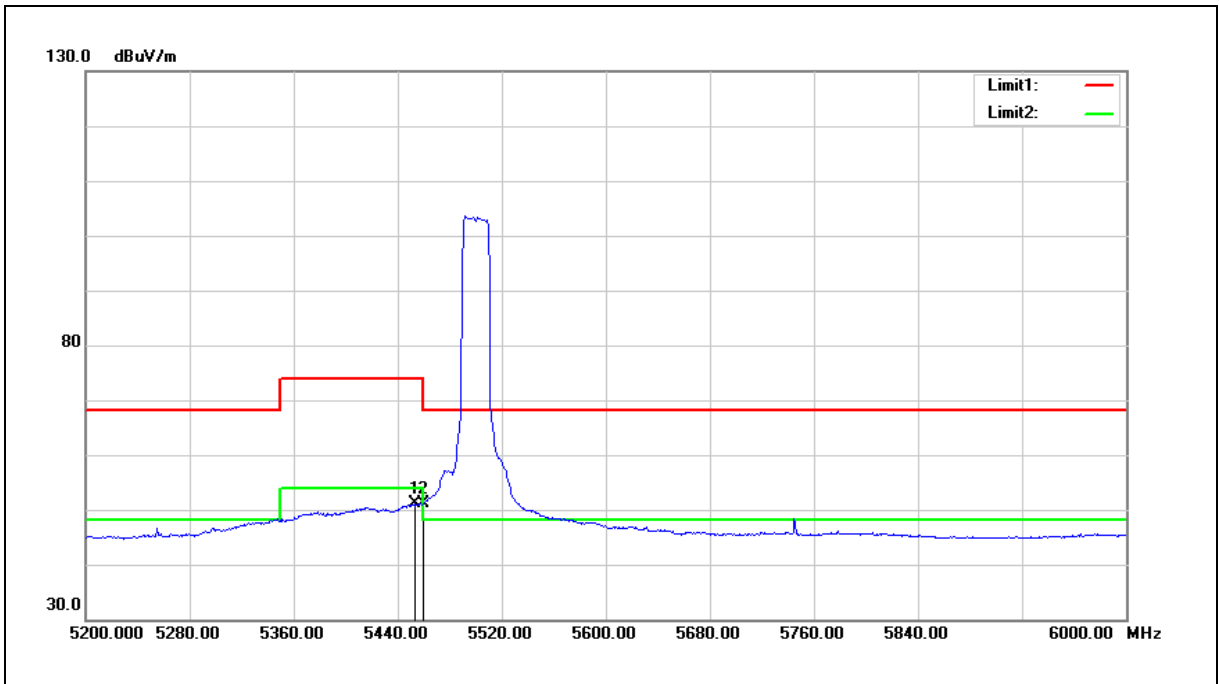

No.	Frequency (MHz)	Reading (dBuV)	Correct Factor (dB/m)	Result (dBuV/m)	Limit (dBuV/m)	Margin (dB)	Remark
1	5453.600	45.01	6.12	51.13	54.00	-2.87	AVG
2	5460.000	45.09	6.14	51.23	54.00	-2.77	AVG

Note:1.Result (dBuV/m) = Correct Factor (dB/m) + Reading(dBuV).

2.Correction factor (dB/m) = Antenna Factor (dB/m) + Cable loss (dB) – Pre-Amplifier gain (dB).

3.When the peak results are less than average limit, so not need to evaluate the average.

Standard:	FCC Part 15.407	Test Distance:	3 m
Test item:	Band edge		
Frequency:	5500 MHz		
Mode:	Mode 8		
Ant.Polar.:	Vertical		

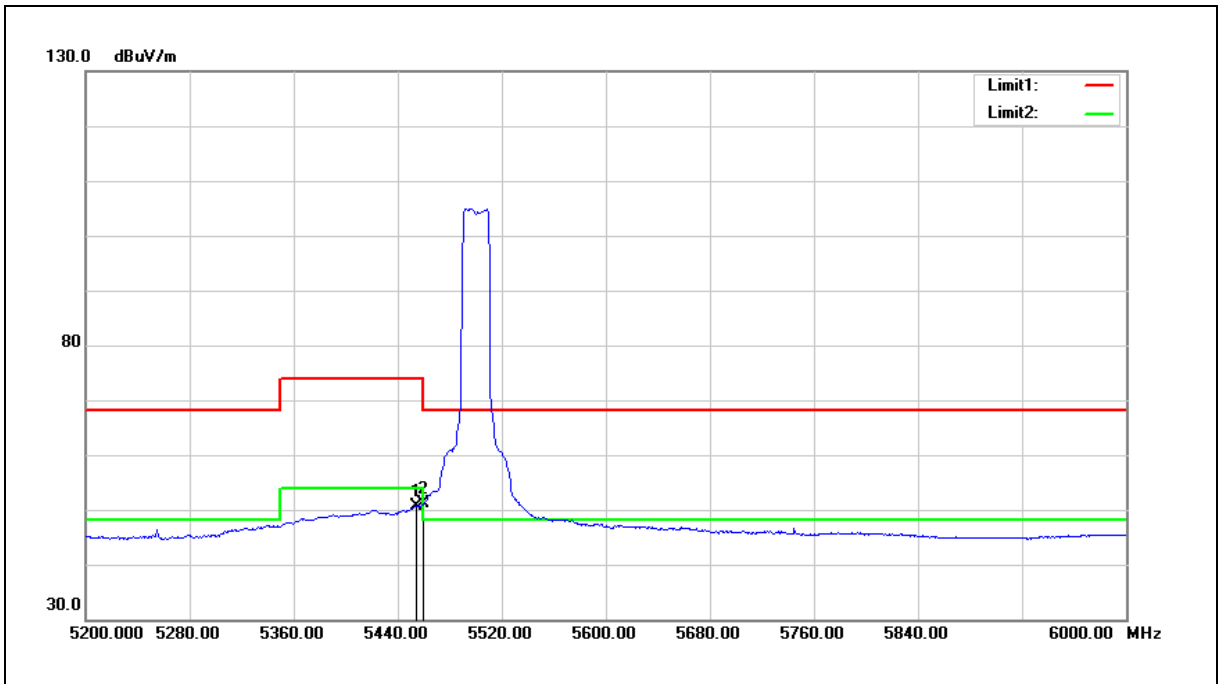

No.	Frequency (MHz)	Reading (dBuV)	Correct Factor (dB/m)	Result (dBuV/m)	Limit (dBuV/m)	Margin (dB)	Remark
1	5454.400	44.53	6.13	50.66	54.00	-3.34	AVG
2	5460.000	45.03	6.14	51.17	54.00	-2.83	AVG

Note:1.Result (dBuV/m) = Correct Factor (dB/m) + Reading(dBuV).

2.Correction factor (dB/m) = Antenna Factor (dB/m) + Cable loss (dB) – Pre-Amplifier gain (dB).

3.When the peak results are less than average limit, so not need to evaluate the average.

Standard:	FCC Part 15.407	Test Distance:	3 m
Test item:	Band edge		
Frequency:	5560 MHz		
Mode:	Mode 8		
Ant.Polar.:	Horizontal		

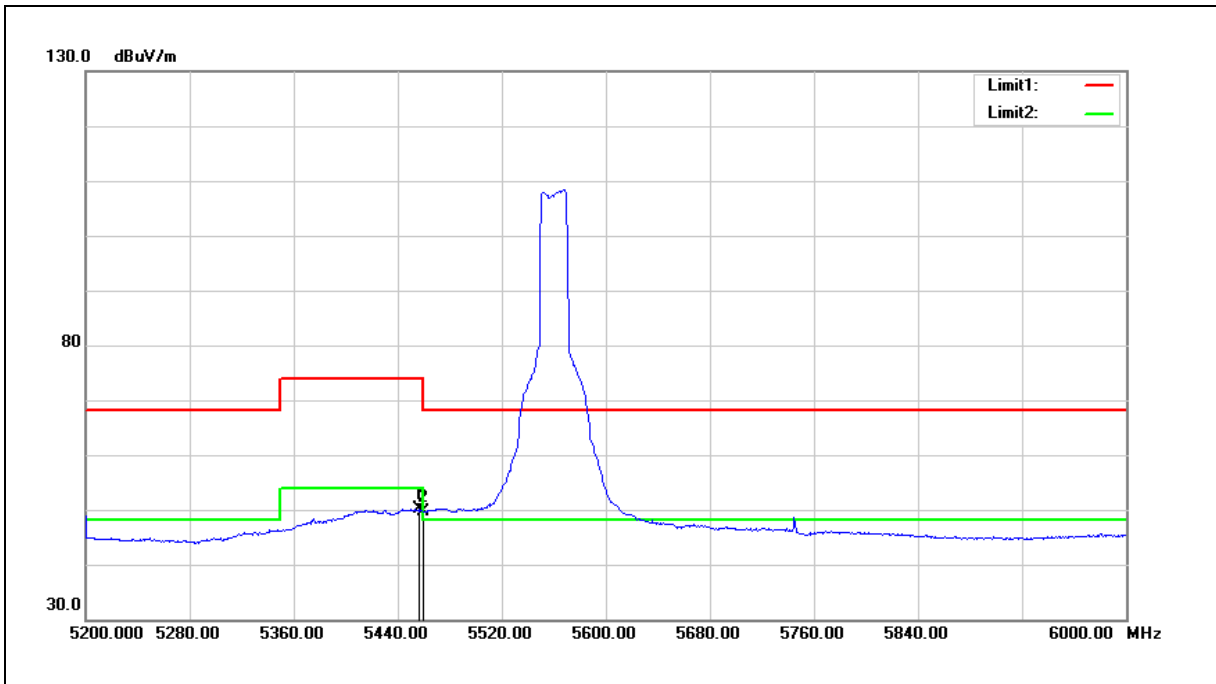

No.	Frequency (MHz)	Reading (dBuV)	Correct Factor (dB/m)	Result (dBuV/m)	Limit (dBuV/m)	Margin (dB)	Remark
1	5456.800	44.02	6.14	50.16	54.00	-3.84	AVG
2	5460.000	43.58	6.14	49.72	54.00	-4.28	AVG

Note:1.Result (dBuV/m) = Correct Factor (dB/m) + Reading(dBuV).

2.Correction factor (dB/m) = Antenna Factor (dB/m) + Cable loss (dB) – Pre-Amplifier gain (dB).

3.When the peak results are less than average limit, so not need to evaluate the average.

Standard:	FCC Part 15.407	Test Distance:	3 m
Test item:	Band edge		
Frequency:	5560 MHz		
Mode:	Mode 8		
Ant.Polar.:	Vertical		

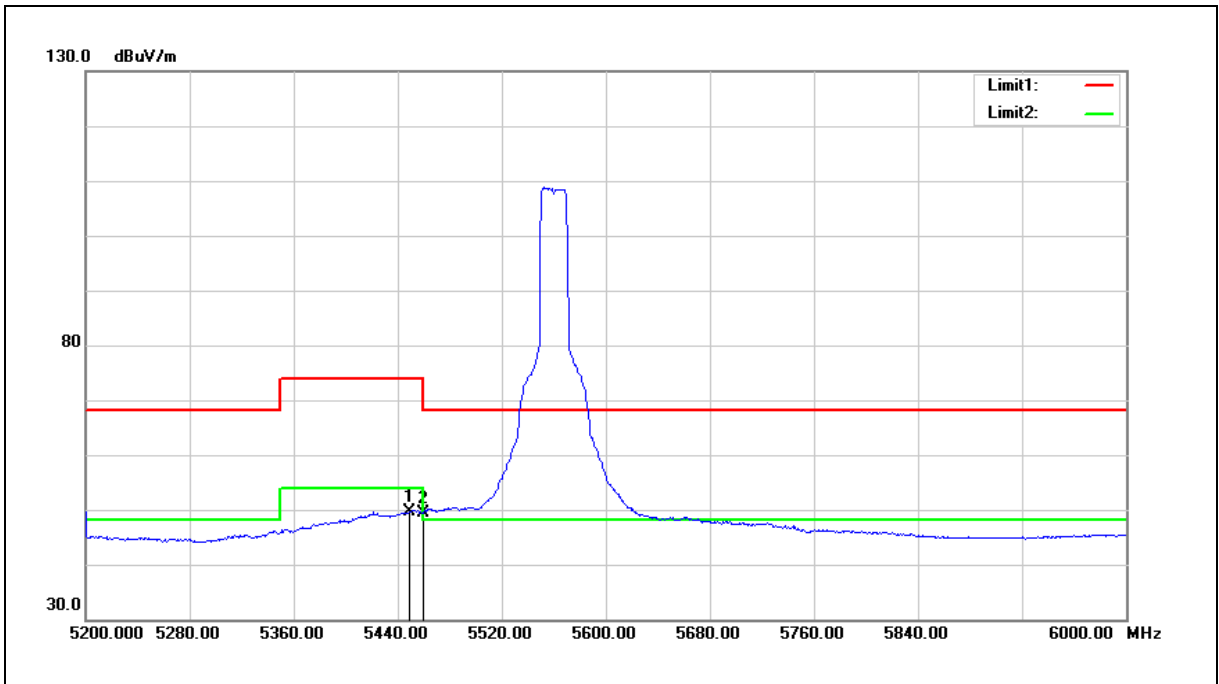

No.	Frequency (MHz)	Reading (dBuV)	Correct Factor (dB/m)	Result (dBuV/m)	Limit (dBuV/m)	Margin (dB)	Remark
1	5448.800	43.57	6.13	49.70	54.00	-4.30	AVG
2	5460.000	43.26	6.14	49.40	54.00	-4.60	AVG

Note:1.Result (dBuV/m) = Correct Factor (dB/m) + Reading(dBuV).

2.Correction factor (dB/m) = Antenna Factor (dB/m) + Cable loss (dB) – Pre-Amplifier gain (dB).

3.When the peak results are less than average limit, so not need to evaluate the average.

Standard:	FCC Part 15.407	Test Distance:	3 m
Test item:	Band edge		
Frequency:	5700 MHz		
Mode:	Mode 8		
Ant.Polar.:	Horizontal		

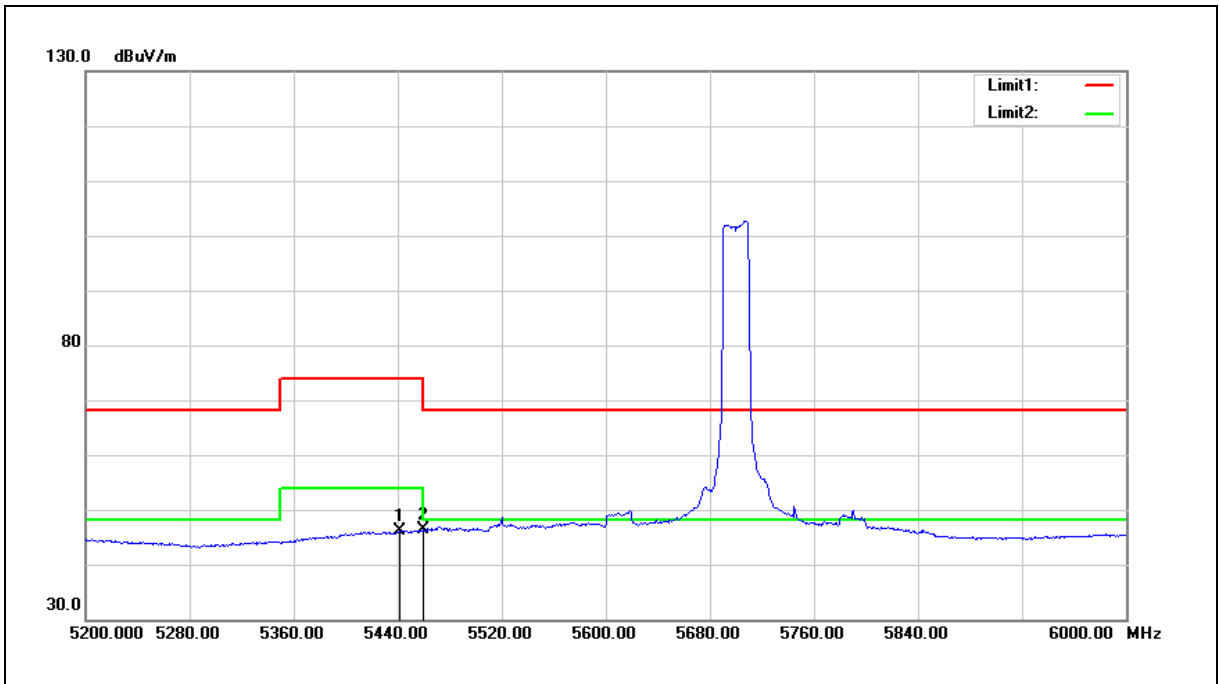

No.	Frequency (MHz)	Reading (dBuV)	Correct Factor (dB/m)	Result (dBuV/m)	Limit (dBuV/m)	Margin (dB)	Remark
1	5441.600	40.11	6.12	46.23	54.00	-7.77	AVG
2	5460.000	40.19	6.14	46.33	54.00	-7.67	AVG

Note:1.Result (dBuV/m) = Correct Factor (dB/m) + Reading(dBuV).

2.Correction factor (dB/m) = Antenna Factor (dB/m) + Cable loss (dB) – Pre-Amplifier gain (dB).

3.When the peak results are less than average limit, so not need to evaluate the average.

Standard:	FCC Part 15.407	Test Distance:	3 m
Test item:	Band edge		
Frequency:	5700 MHz		
Mode:	Mode 8		
Ant.Polar.:	Vertical		

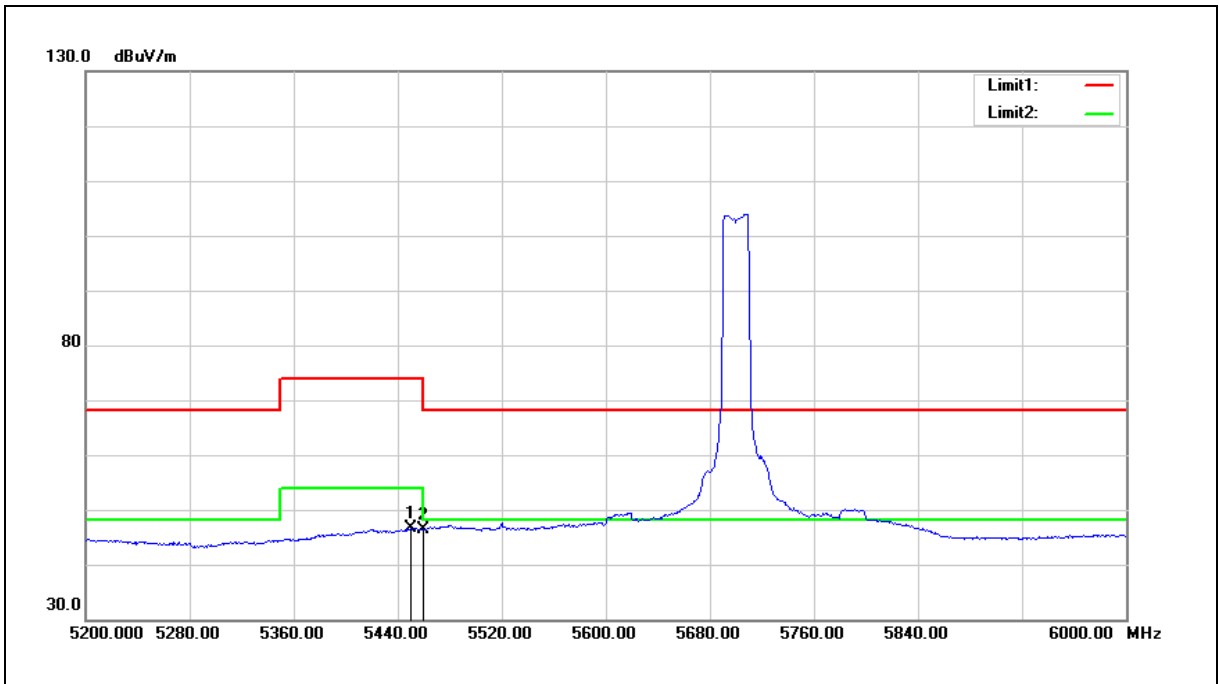

No.	Frequency (MHz)	Reading (dBuV)	Correct Factor (dB/m)	Result (dBuV/m)	Limit (dBuV/m)	Margin (dB)	Remark
1	5450.400	40.40	6.12	46.52	54.00	-7.48	AVG
2	5460.000	40.24	6.14	46.38	54.00	-7.62	AVG

Note:1.Result (dBuV/m) = Correct Factor (dB/m) + Reading(dBuV).

2.Correction factor (dB/m) = Antenna Factor (dB/m) + Cable loss (dB) – Pre-Amplifier gain (dB).

3.When the peak results are less than average limit, so not need to evaluate the average.

Standard:	FCC Part 15.407	Test Distance:	3 m
Test item:	Band edge		
Frequency:	5720 MHz		
Mode:	Mode 8		
Ant.Polar.:	Horizontal		

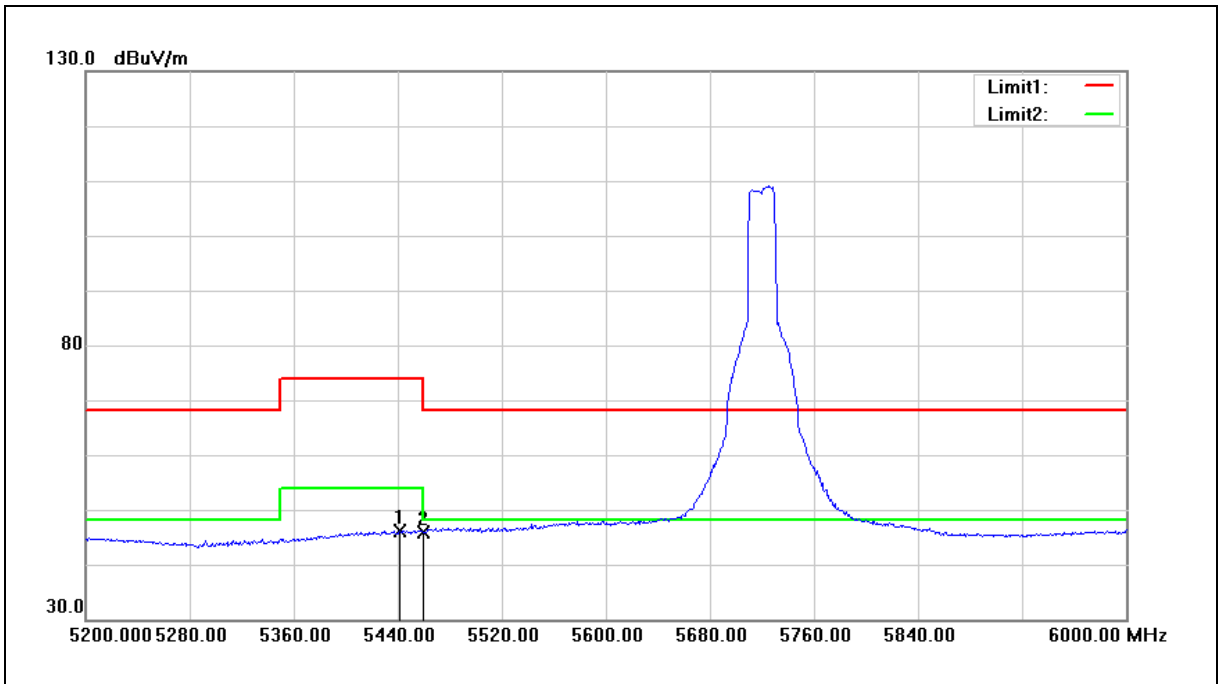

No.	Frequency (MHz)	Reading (dBuV)	Correct Factor (dB/m)	Result (dBuV/m)	Limit (dBuV/m)	Margin (dB)	Remark
1	5441.600	40.11	6.12	46.23	54.00	-7.77	AVG
2	5460.000	39.79	6.14	45.93	54.00	-8.07	AVG

- Note:1.Result (dBuV/m) = Correct Factor (dB/m) + Reading(dBuV).
- 2.Correction factor (dB/m) = Antenna Factor (dB/m) + Cable loss (dB) – Pre-Amplifier gain (dB).
- 3.When the peak results are less than average limit, so not need to evaluate the average.

Standard:	FCC Part 15.407	Test Distance:	3 m
Test item:	Band edge		
Frequency:	5720 MHz		
Mode:	Mode 8		
Ant.Polar.:	Vertical		

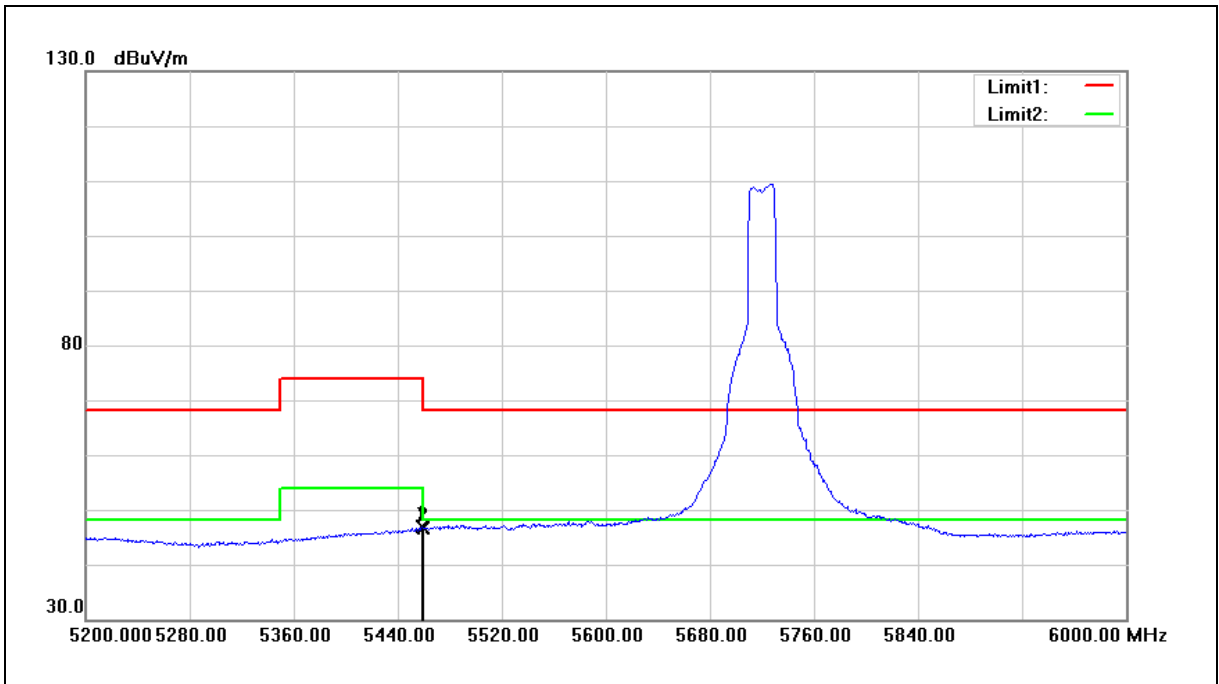

No.	Frequency (MHz)	Reading (dBuV)	Correct Factor (dB/m)	Result (dBuV/m)	Limit (dBuV/m)	Margin (dB)	Remark
1	5458.400	40.69	6.14	46.83	54.00	-7.17	AVG
2	5460.000	40.49	6.14	46.63	54.00	-7.37	AVG

Note:1.Result (dBuV/m) = Correct Factor (dB/m) + Reading(dBuV).

2.Correction factor (dB/m) = Antenna Factor (dB/m) + Cable loss (dB) – Pre-Amplifier gain (dB).

3.When the peak results are less than average limit, so not need to evaluate the average.

Standard:	FCC Part 15.407	Test Distance:	3 m
Test item:	Band edge		
Frequency:	5270 MHz		
Mode:	Mode 9		
Ant.Polar.:	Horizontal		

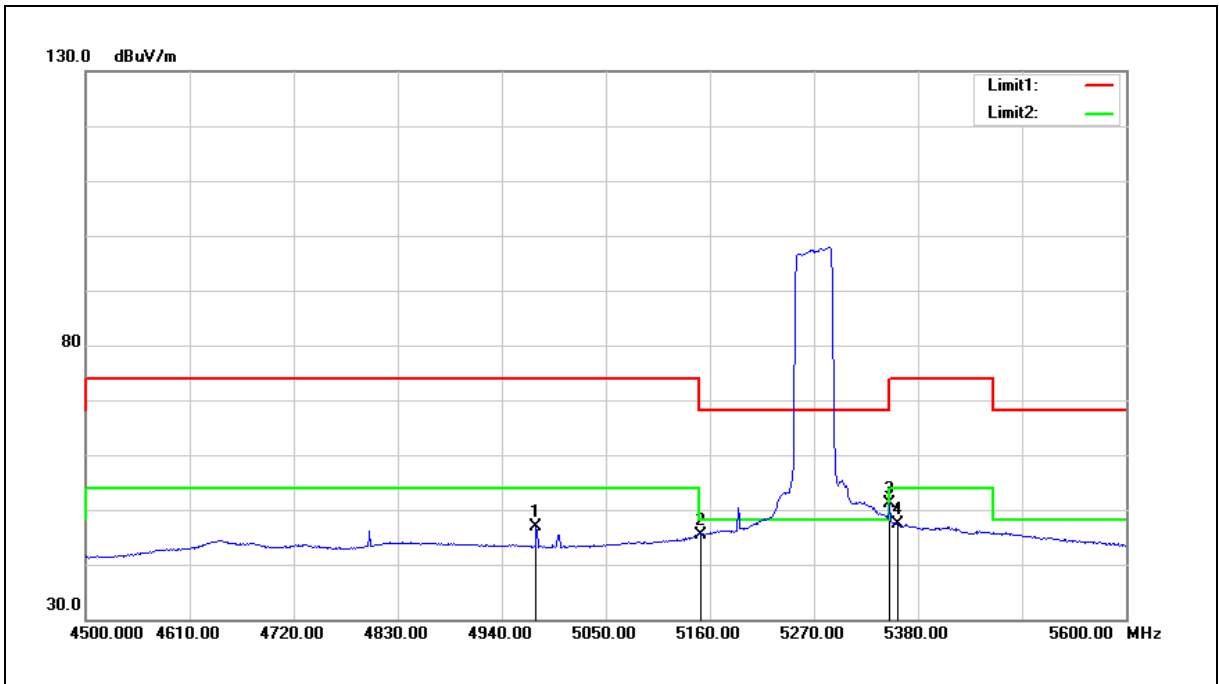

No.	Frequency (MHz)	Reading (dBuV)	Correct Factor (dB/m)	Result (dBuV/m)	Limit (dBuV/m)	Margin (dB)	Remark
1	4976.300	41.49	5.50	46.99	54.00	-7.01	AVG
2	5150.000	39.62	5.75	45.37	54.00	-8.63	AVG
3	5350.000	45.09	6.00	51.09	54.00	-2.91	AVG
4	5359.100	41.41	6.01	47.42	54.00	-6.58	AVG

Note:1.Result (dBuV/m) = Correct Factor (dB/m) + Reading(dBuV).

2.Correction factor (dB/m) = Antenna Factor (dB/m) + Cable loss (dB) – Pre-Amplifier gain (dB).

3.When the peak results are less than average limit, so not need to evaluate the average.

Standard:	FCC Part 15.407	Test Distance:	3 m
Test item:	Band edge		
Frequency:	5270 MHz		
Mode:	Mode 9		
Ant.Polar.:	Vertical		

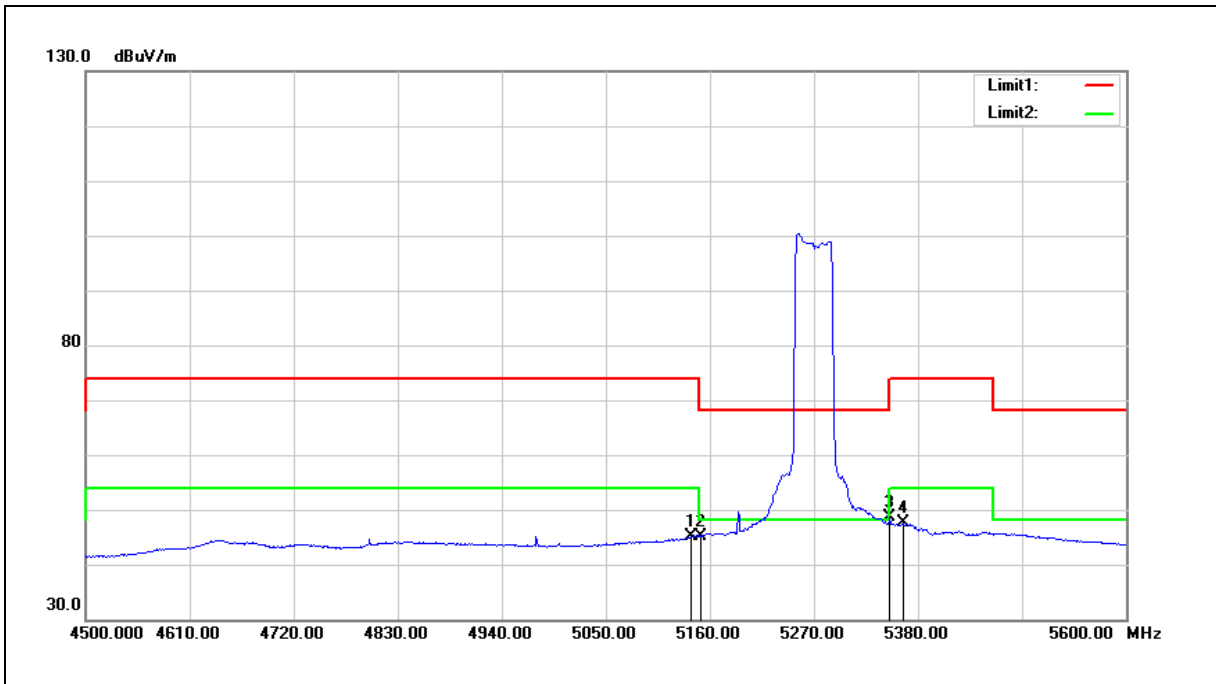

No.	Frequency (MHz)	Reading (dBuV)	Correct Factor (dB/m)	Result (dBuV/m)	Limit (dBuV/m)	Margin (dB)	Remark
1	5140.200	39.38	5.75	45.13	54.00	-8.87	AVG
2	5150.000	39.47	5.75	45.22	54.00	-8.78	AVG
3	5350.000	42.71	6.00	48.71	54.00	-5.29	AVG
4	5364.600	41.54	6.02	47.56	54.00	-6.44	AVG

Note:1.Result (dBuV/m) = Correct Factor (dB/m) + Reading(dBuV).

2.Correction factor (dB/m) = Antenna Factor (dB/m) + Cable loss (dB) – Pre-Amplifier gain (dB).

3.When the peak results are less than average limit, so not need to evaluate the average.

Standard:	FCC Part 15.407	Test Distance:	3 m
Test item:	Band edge		
Frequency:	5310 MHz		
Mode:	Mode 9		
Ant.Polar.:	Horizontal		

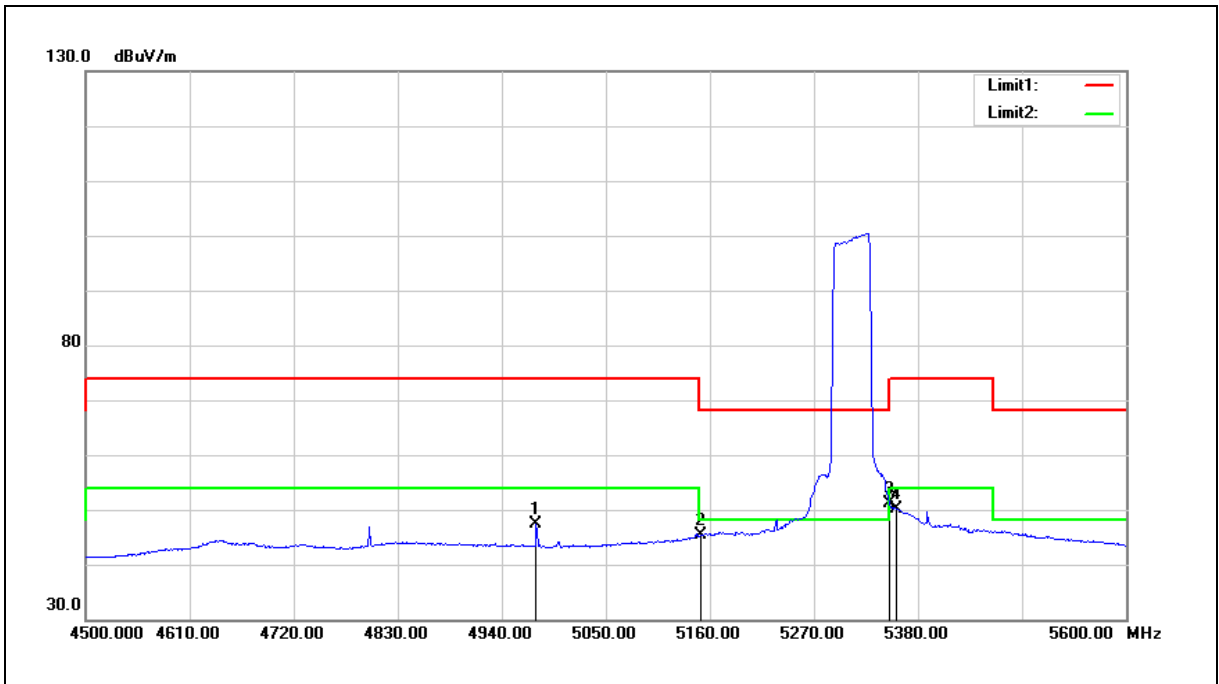

No.	Frequency (MHz)	Reading (dBuV)	Correct Factor (dB/m)	Result (dBuV/m)	Limit (dBuV/m)	Margin (dB)	Remark
1	4976.300	41.89	5.50	47.39	54.00	-6.61	AVG
2	5150.000	39.63	5.75	45.38	54.00	-8.62	AVG
3	5350.000	45.10	6.00	51.10	54.00	-2.90	AVG
4	5356.900	44.24	6.01	50.25	54.00	-3.75	AVG

Note:1.Result (dBuV/m) = Correct Factor (dB/m) + Reading(dBuV).

2.Correction factor (dB/m) = Antenna Factor (dB/m) + Cable loss (dB) – Pre-Amplifier gain (dB).

3.When the peak results are less than average limit, so not need to evaluate the average.

Standard:	FCC Part 15.407	Test Distance:	3 m
Test item:	Band edge		
Frequency:	5310 MHz		
Mode:	Mode 9		
Ant.Polar.:	Vertical		

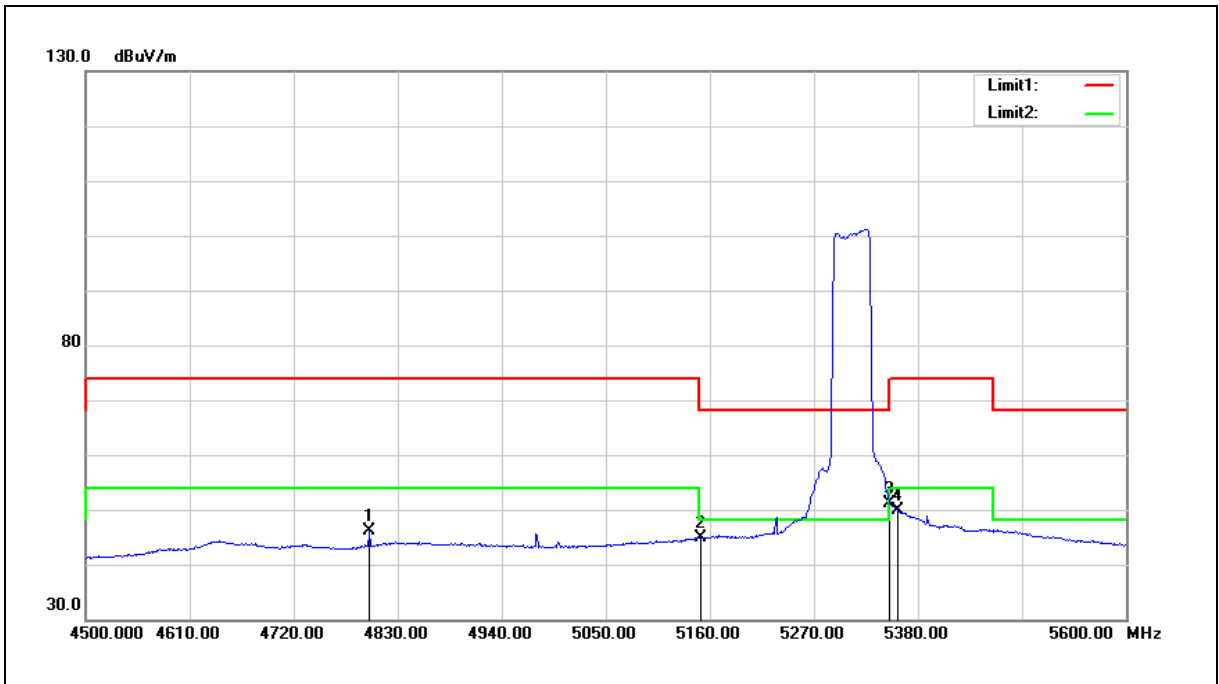

No.	Frequency (MHz)	Reading (dBuV)	Correct Factor (dB/m)	Result (dBuV/m)	Limit (dBuV/m)	Margin (dB)	Remark
1	4800.300	41.15	5.02	46.17	54.00	-7.83	AVG
2	5150.000	39.08	5.75	44.83	54.00	-9.17	AVG
3	5350.000	45.07	6.00	51.07	54.00	-2.93	AVG
4	5359.100	43.77	6.01	49.78	54.00	-4.22	AVG

Note:1.Result (dBuV/m) = Correct Factor (dB/m) + Reading(dBuV).

2.Correction factor (dB/m) = Antenna Factor (dB/m) + Cable loss (dB) – Pre-Amplifier gain (dB).

3.When the peak results are less than average limit, so not need to evaluate the average.

Standard:	FCC Part 15.407	Test Distance:	3 m
Test item:	Band edge		
Frequency:	5510 MHz		
Mode:	Mode 9		
Ant.Polar.:	Horizontal		

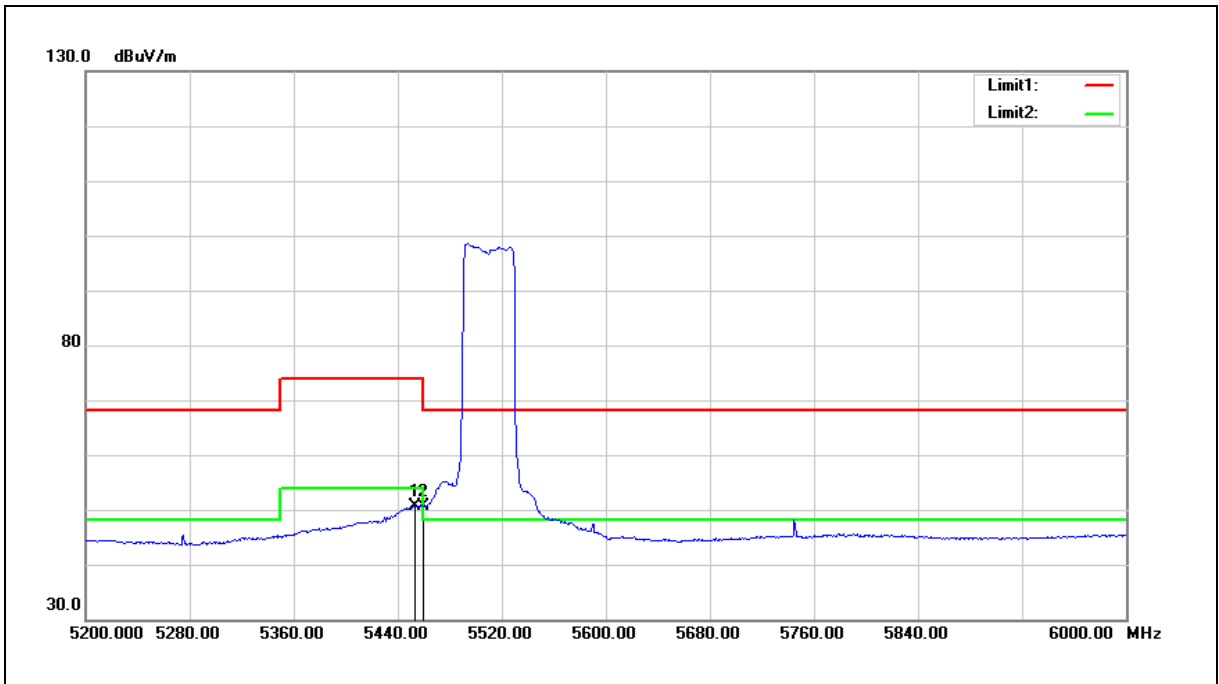

No.	Frequency (MHz)	Reading (dBuV)	Correct Factor (dB/m)	Result (dBuV/m)	Limit (dBuV/m)	Margin (dB)	Remark
1	5452.800	44.62	6.12	50.74	54.00	-3.26	AVG
2	5460.000	44.42	6.14	50.56	54.00	-3.44	AVG

Note:1.Result (dBuV/m) = Correct Factor (dB/m) + Reading(dBuV).

2.Correction factor (dB/m) = Antenna Factor (dB/m) + Cable loss (dB) – Pre-Amplifier gain (dB).

3.When the peak results are less than average limit, so not need to evaluate the average.

Standard:	FCC Part 15.407	Test Distance:	3 m
Test item:	Band edge		
Frequency:	5510 MHz		
Mode:	Mode 9		
Ant.Polar.:	Vertical		

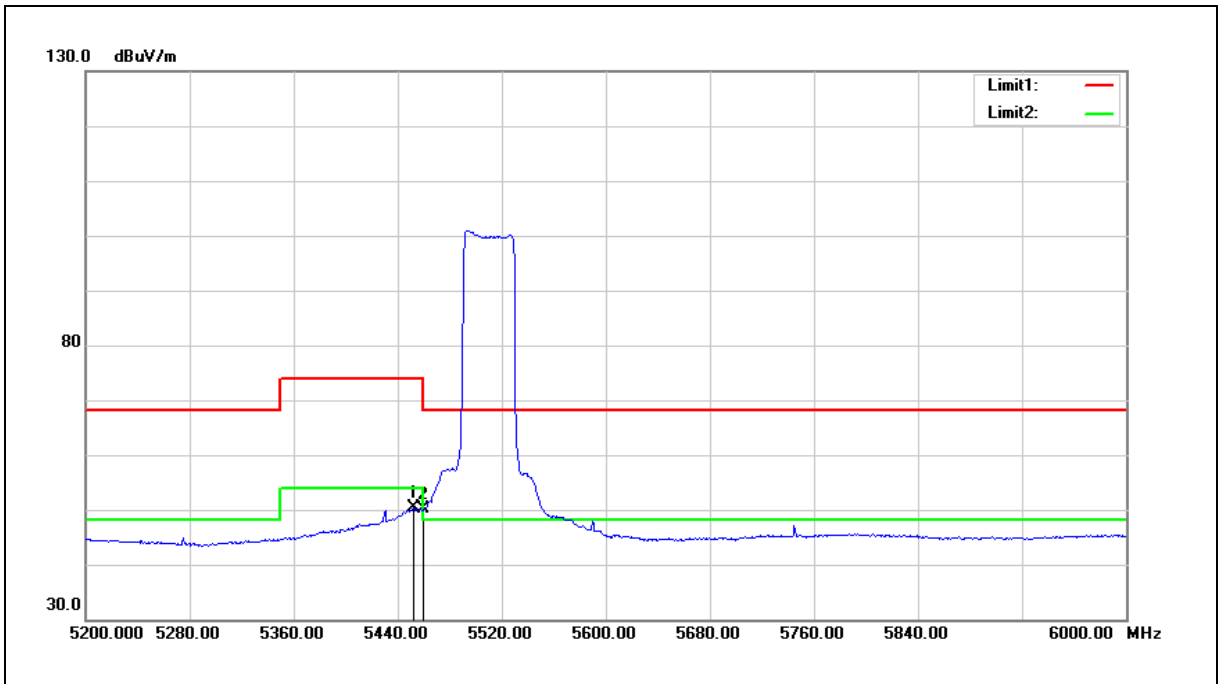

No.	Frequency (MHz)	Reading (dBuV)	Correct Factor (dB/m)	Result (dBuV/m)	Limit (dBuV/m)	Margin (dB)	Remark
1	5452.000	44.19	6.12	50.31	54.00	-3.69	AVG
2	5460.000	43.90	6.14	50.04	54.00	-3.96	AVG

- Note: 1. Result (dBuV/m) = Correct Factor (dB/m) + Reading (dBuV).
 2. Correction factor (dB/m) = Antenna Factor (dB/m) + Cable loss (dB) – Pre-Amplifier gain (dB).
 3. When the peak results are less than average limit, so not need to evaluate the average.

Standard:	FCC Part 15.407	Test Distance:	3 m
Test item:	Band edge		
Frequency:	5550 MHz		
Mode:	Mode 9		
Ant.Polar.:	Horizontal		

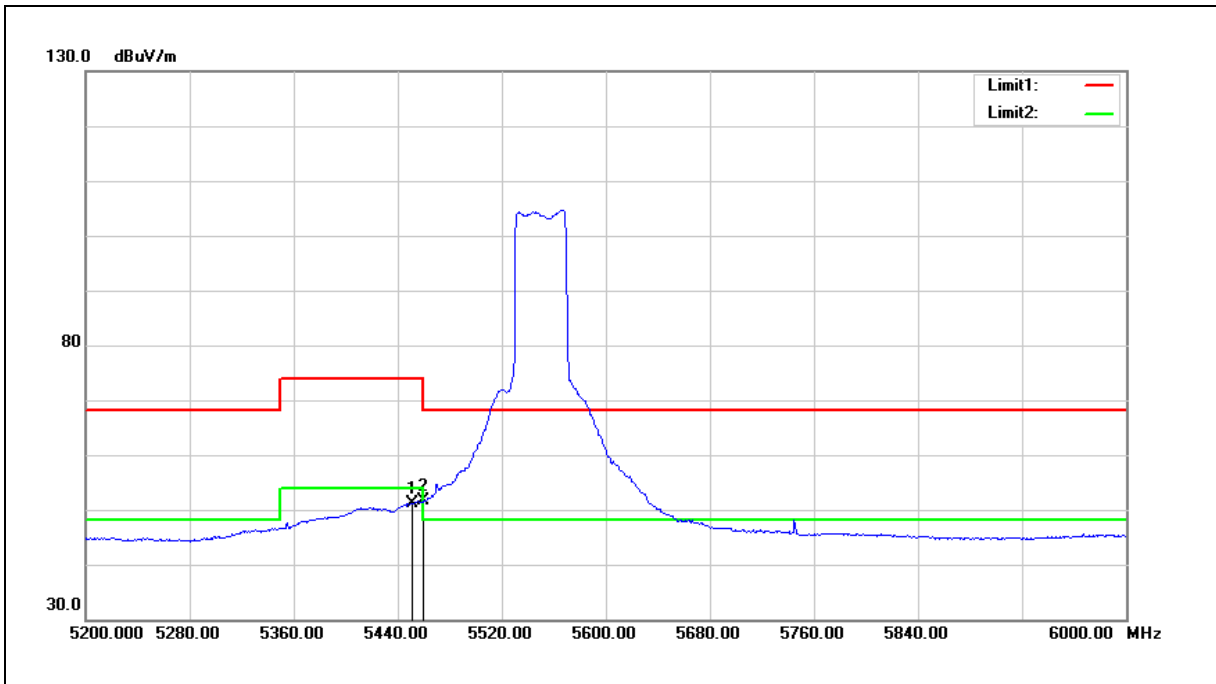

No.	Frequency (MHz)	Reading (dBuV)	Correct Factor (dB/m)	Result (dBuV/m)	Limit (dBuV/m)	Margin (dB)	Remark
1	5451.200	45.12	6.12	51.24	54.00	-2.76	AVG
2	5460.000	45.50	6.14	51.64	54.00	-2.36	AVG

Note:1.Result (dBuV/m) = Correct Factor (dB/m) + Reading(dBuV).

2.Correction factor (dB/m) = Antenna Factor (dB/m) + Cable loss (dB) – Pre-Amplifier gain (dB).

3.When the peak results are less than average limit, so not need to evaluate the average.

Standard:	FCC Part 15.407	Test Distance:	3 m
Test item:	Band edge		
Frequency:	5550 MHz		
Mode:	Mode 9		
Ant.Polar.:	Vertical		

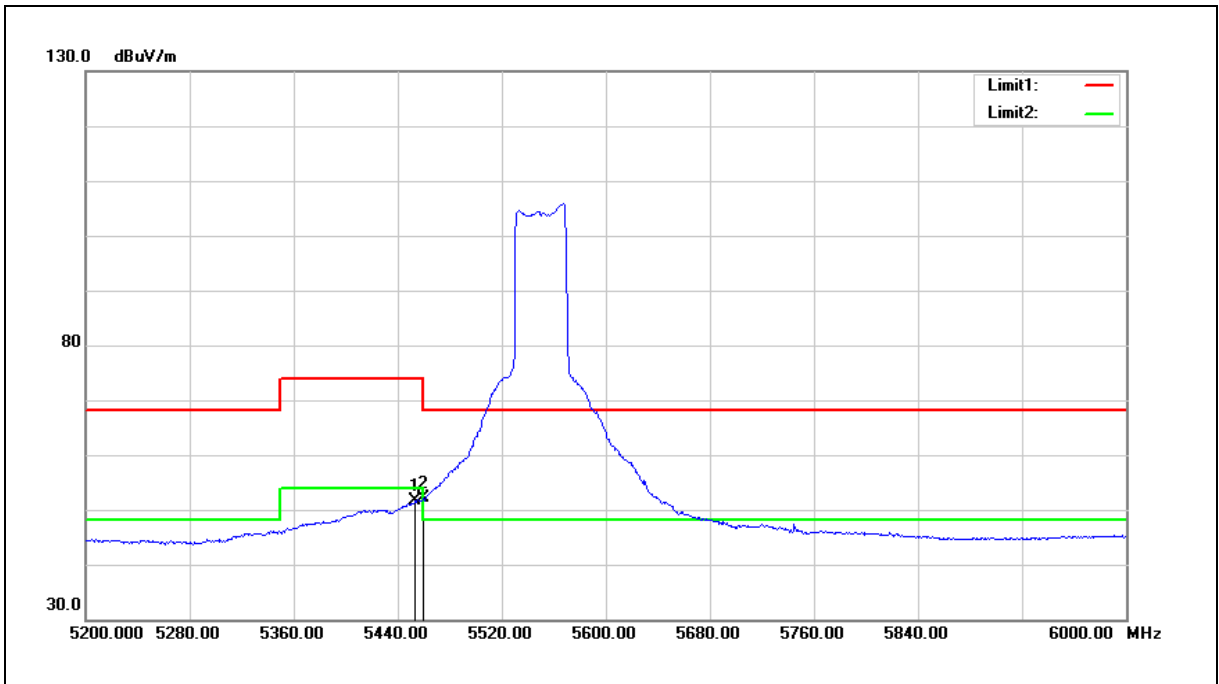

No.	Frequency (MHz)	Reading (dBuV)	Correct Factor (dB/m)	Result (dBuV/m)	Limit (dBuV/m)	Margin (dB)	Remark
1	5453.600	45.46	6.12	51.58	54.00	-2.42	AVG
2	5460.000	45.96	6.14	52.10	54.00	-1.90	AVG

Note:1.Result (dBuV/m) = Correct Factor (dB/m) + Reading(dBuV).

2.Correction factor (dB/m) = Antenna Factor (dB/m) + Cable loss (dB) – Pre-Amplifier gain (dB).

3.When the peak results are less than average limit, so not need to evaluate the average.

Standard:	FCC Part 15.407	Test Distance:	3 m
Test item:	Band edge		
Frequency:	5670 MHz		
Mode:	Mode 9		
Ant.Polar.:	Horizontal		

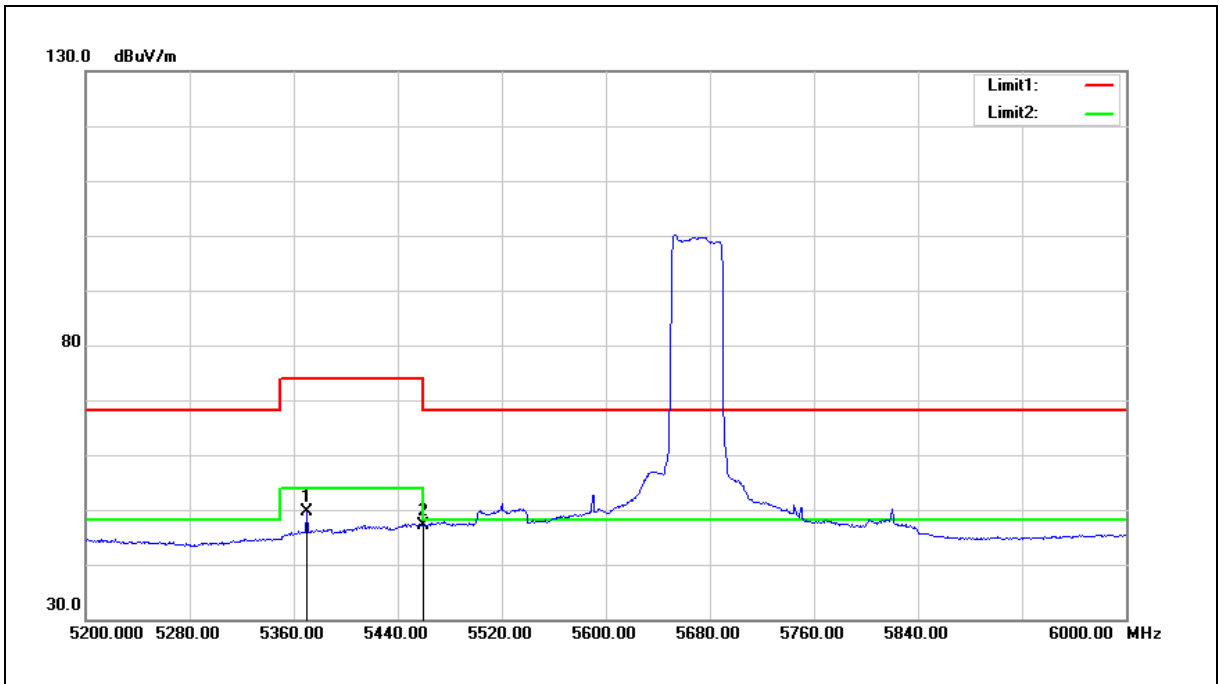

No.	Frequency (MHz)	Reading (dBuV)	Correct Factor (dB/m)	Result (dBuV/m)	Limit (dBuV/m)	Margin (dB)	Remark
1	5369.600	43.61	6.03	49.64	54.00	-4.36	AVG
2	5460.000	40.97	6.14	47.11	54.00	-6.89	AVG

- Note:1.Result (dBuV/m) = Correct Factor (dB/m) + Reading(dBuV).
 2.Correction factor (dB/m) = Antenna Factor (dB/m) + Cable loss (dB) – Pre-Amplifier gain (dB).
 3.When the peak results are less than average limit, so not need to evaluate the average.

Standard:	FCC Part 15.407	Test Distance:	3 m
Test item:	Band edge		
Frequency:	5670 MHz		
Mode:	Mode 9		
Ant.Polar.:	Vertical		

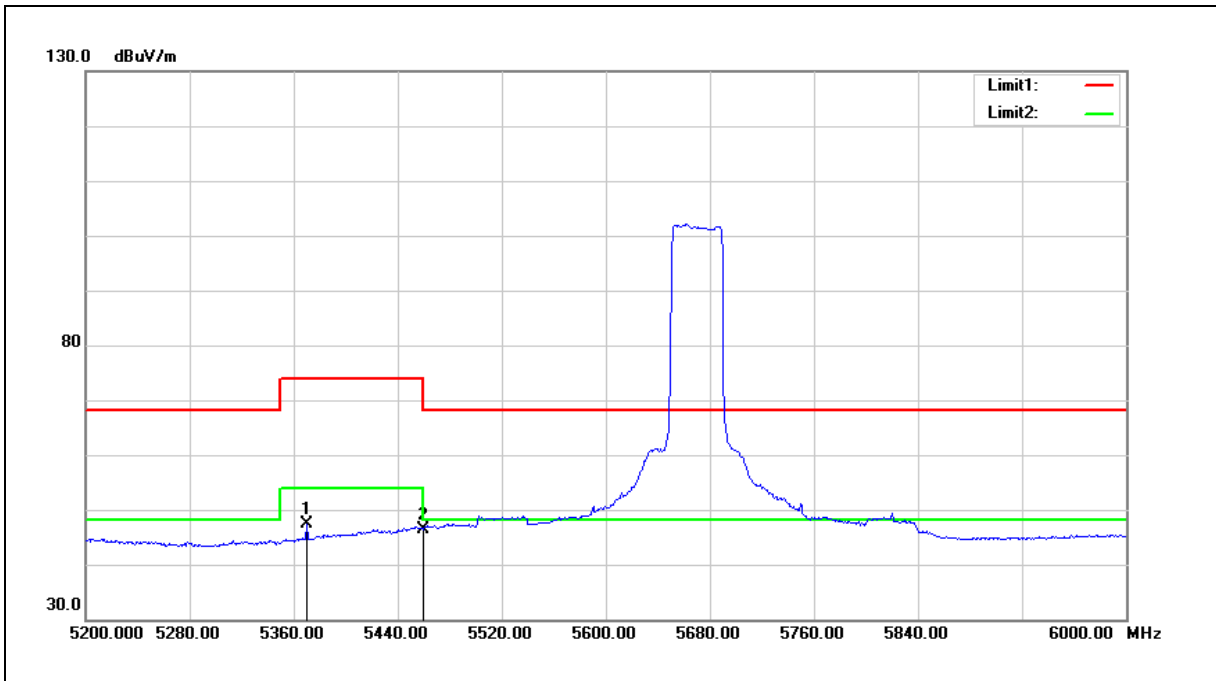

No.	Frequency (MHz)	Reading (dBuV)	Correct Factor (dB/m)	Result (dBuV/m)	Limit (dBuV/m)	Margin (dB)	Remark
1	5369.600	41.38	6.03	47.41	54.00	-6.59	AVG
2	5460.000	40.22	6.14	46.36	54.00	-7.64	AVG

- Note:1.Result (dBuV/m) = Correct Factor (dB/m) + Reading(dBuV).
 2.Correction factor (dB/m) = Antenna Factor (dB/m) + Cable loss (dB) – Pre-Amplifier gain (dB).
 3.When the peak results are less than average limit, so not need to evaluate the average.

Standard:	FCC Part 15.407	Test Distance:	3 m
Test item:	Band edge		
Frequency:	5710 MHz		
Mode:	Mode 9		
Ant.Polar.:	Horizontal		

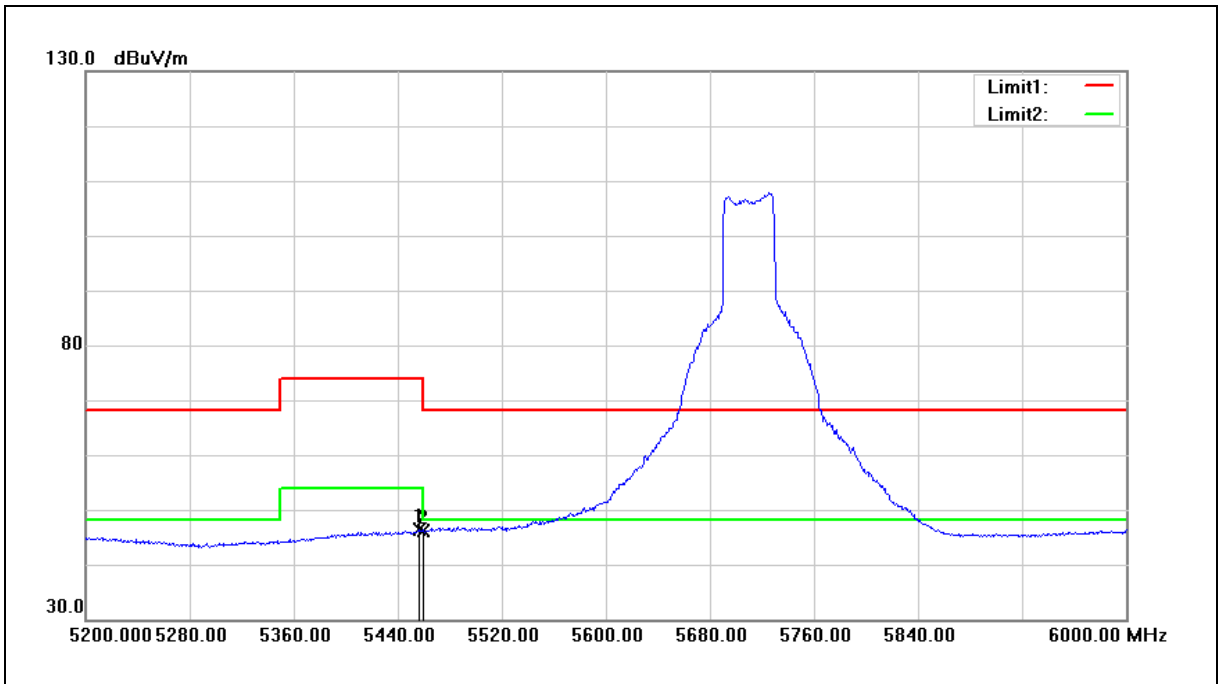

No.	Frequency (MHz)	Reading (dBuV)	Correct Factor (dB/m)	Result (dBuV/m)	Limit (dBuV/m)	Margin (dB)	Remark
1	5456.000	40.18	6.13	46.31	54.00	-7.69	AVG
2	5460.000	40.11	6.14	46.25	54.00	-7.75	AVG

Note:1.Result (dBuV/m) = Correct Factor (dB/m) + Reading(dBuV).

2.Correction factor (dB/m) = Antenna Factor (dB/m) + Cable loss (dB) – Pre-Amplifier gain (dB).

3.When the peak results are less than average limit, so not need to evaluate the average.

Standard:	FCC Part 15.407	Test Distance:	3 m
Test item:	Band edge		
Frequency:	5710 MHz		
Mode:	Mode 9		
Ant.Polar.:	Vertical		

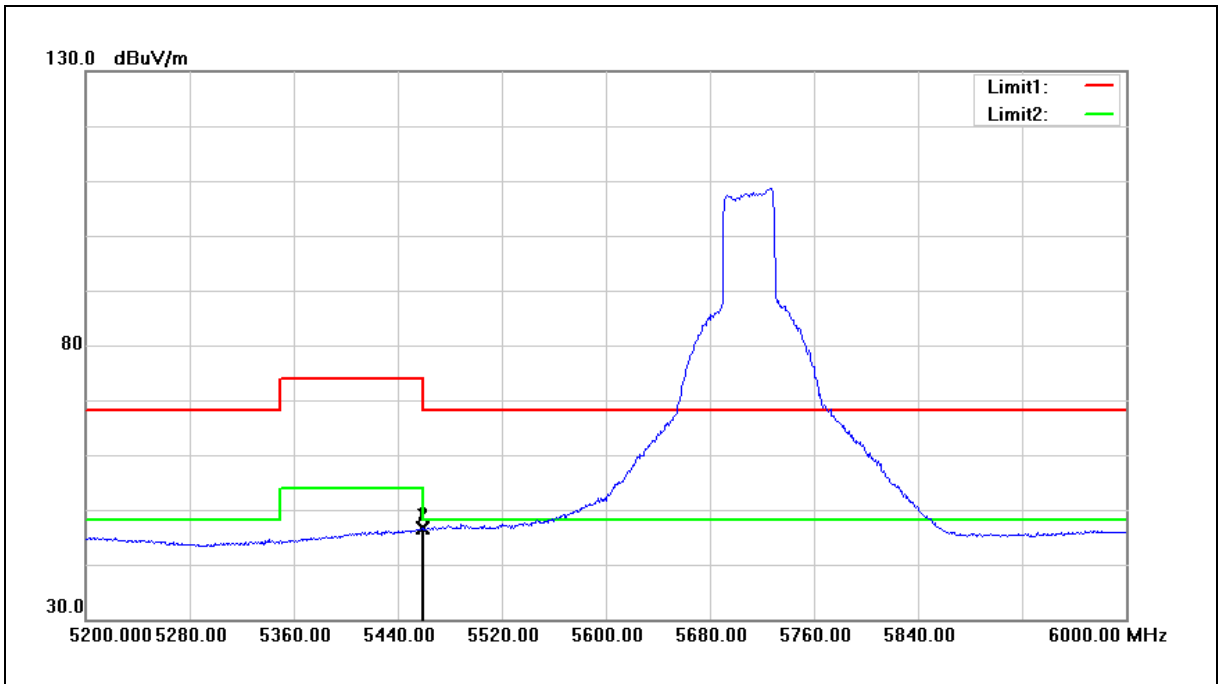

No.	Frequency (MHz)	Reading (dBuV)	Correct Factor (dB/m)	Result (dBuV/m)	Limit (dBuV/m)	Margin (dB)	Remark
1	5458.400	40.39	6.14	46.53	54.00	-7.47	AVG
2	5460.000	40.37	6.14	46.51	54.00	-7.49	AVG

Note:1.Result (dBuV/m) = Correct Factor (dB/m) + Reading(dBuV).

2.Correction factor (dB/m) = Antenna Factor (dB/m) + Cable loss (dB) – Pre-Amplifier gain (dB).

3.When the peak results are less than average limit, so not need to evaluate the average.

Standard:	FCC Part 15.407	Test Distance:	3 m
Test item:	Band edge		
Frequency:	5290 MHz		
Mode:	Mode 10		
Ant.Polar.:	Horizontal		

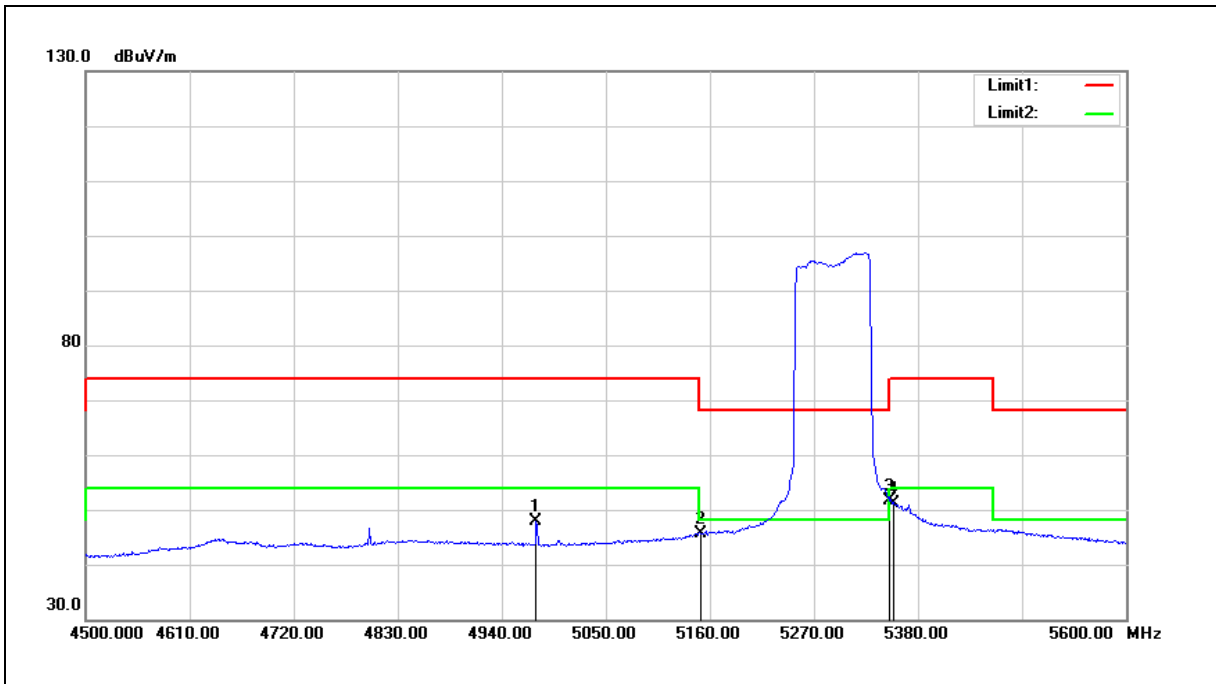

No.	Frequency (MHz)	Reading (dBuV)	Correct Factor (dB/m)	Result (dBuV/m)	Limit (dBuV/m)	Margin (dB)	Remark
1	4976.300	42.25	5.56	47.81	54.00	-6.19	AVG
2	5150.000	39.83	5.81	45.64	54.00	-8.36	AVG
3	5350.000	45.67	6.03	51.70	54.00	-2.30	AVG
4	5354.700	45.18	6.04	51.22	54.00	-2.78	AVG

Note:1.Result (dBuV/m) = Correct Factor (dB/m) + Reading(dBuV).

2.Correction factor (dB/m) = Antenna Factor (dB/m) + Cable loss (dB) – Pre-Amplifier gain (dB).

3.When the peak results are less than average limit, so not need to evaluate the average.

Standard:	FCC Part 15.407	Test Distance:	3 m
Test item:	Band edge		
Frequency:	5290 MHz		
Mode:	Mode 10		
Ant.Polar.:	Vertical		

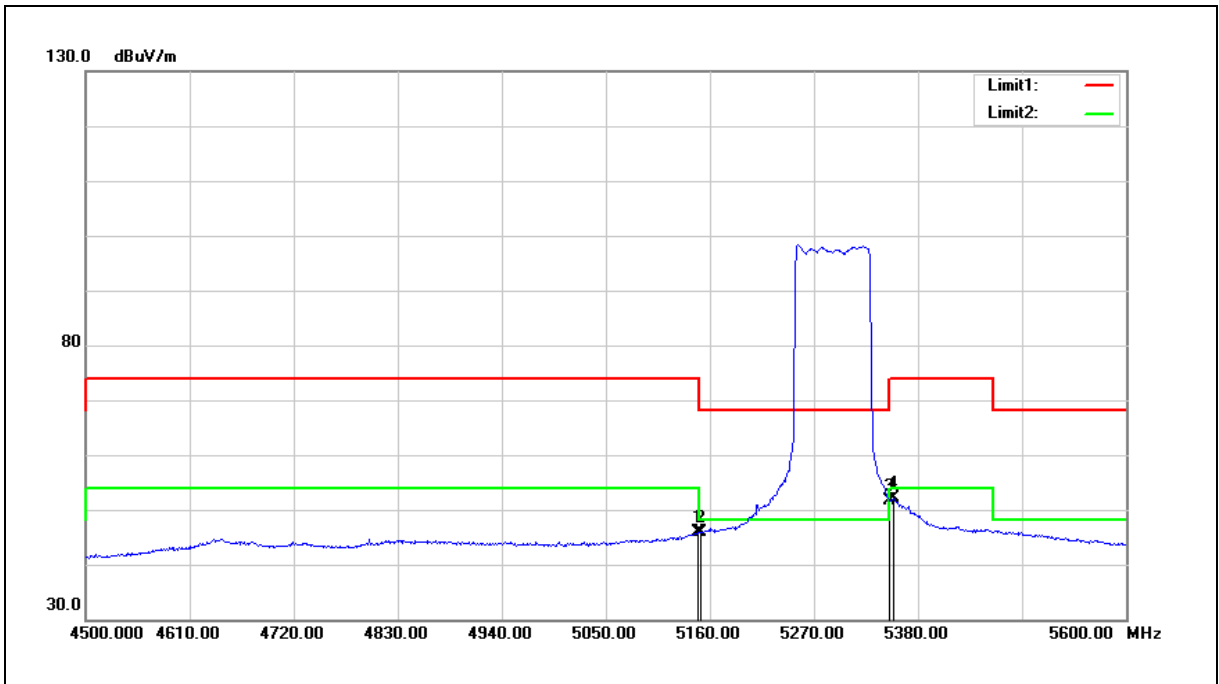

No.	Frequency (MHz)	Reading (dBuV)	Correct Factor (dB/m)	Result (dBuV/m)	Limit (dBuV/m)	Margin (dB)	Remark
1	5147.900	40.00	5.82	45.82	54.00	-8.18	AVG
2	5150.000	40.11	5.81	45.92	54.00	-8.08	AVG
3	5350.000	45.57	6.03	51.60	54.00	-2.40	AVG
4	5354.700	46.06	6.04	52.10	54.00	-1.90	AVG

Note:1.Result (dBuV/m) = Correct Factor (dB/m) + Reading(dBuV).

2.Correction factor (dB/m) = Antenna Factor (dB/m) + Cable loss (dB) – Pre-Amplifier gain (dB).

3.When the peak results are less than average limit, so not need to evaluate the average.

Standard:	FCC Part 15.407	Test Distance:	3 m
Test item:	Band edge		
Frequency:	5530 MHz		
Mode:	Mode 10		
Ant.Polar.:	Horizontal		

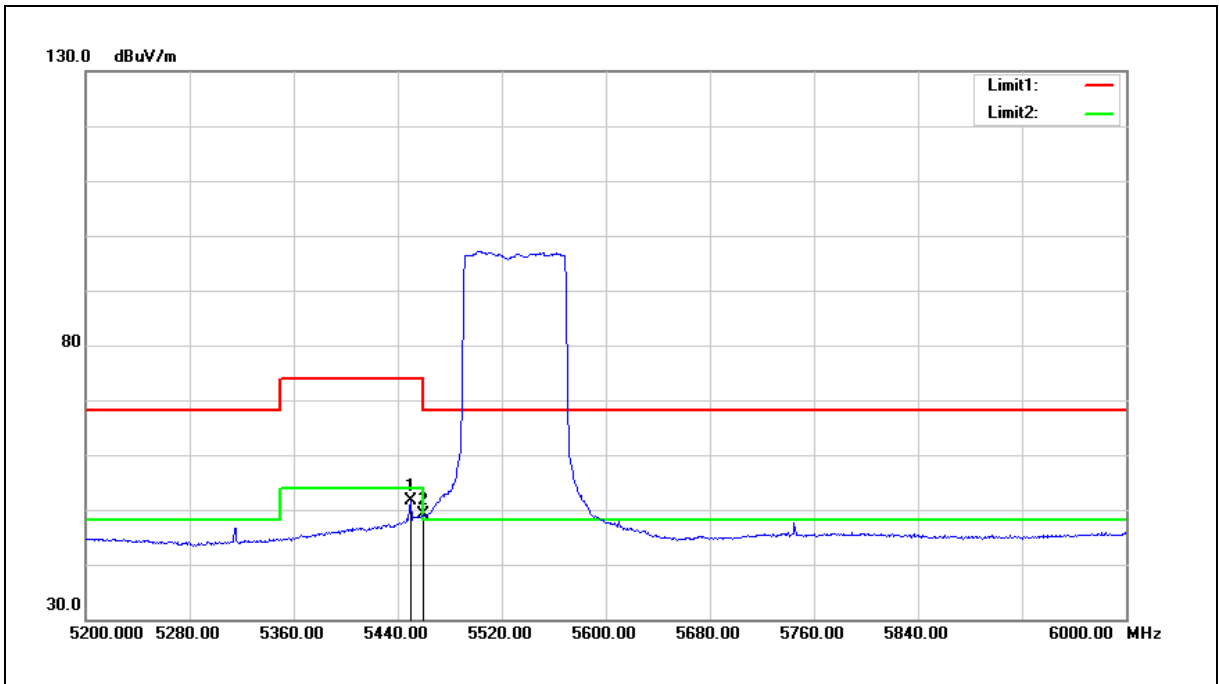

No.	Frequency (MHz)	Reading (dBuV)	Correct Factor (dB/m)	Result (dBuV/m)	Limit (dBuV/m)	Margin (dB)	Remark
1	5449.600	45.48	6.16	51.64	54.00	-2.36	AVG
2	5460.000	43.00	6.16	49.16	54.00	-4.84	AVG

Note:1.Result (dBuV/m) = Correct Factor (dB/m) + Reading(dBuV).

2.Correction factor (dB/m) = Antenna Factor (dB/m) + Cable loss (dB) – Pre-Amplifier gain (dB).

3.When the peak results are less than average limit, so not need to evaluate the average.

Standard:	FCC Part 15.407	Test Distance:	3 m
Test item:	Band edge		
Frequency:	5530 MHz		
Mode:	Mode 10		
Ant.Polar.:	Vertical		

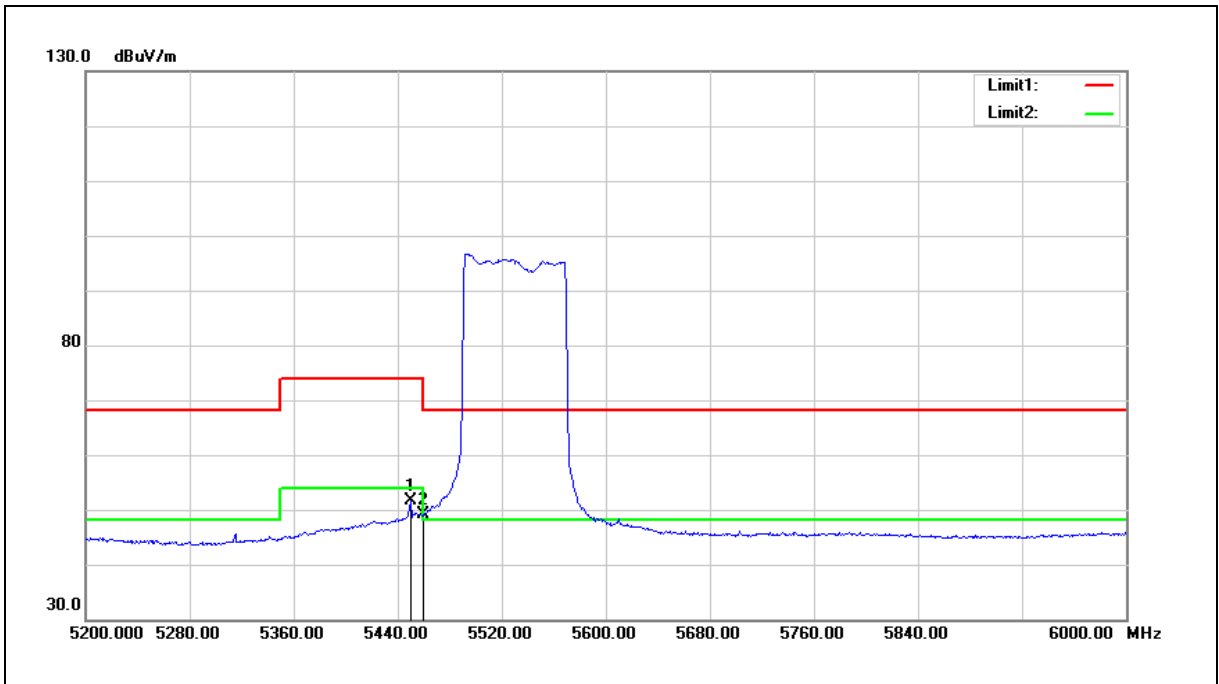

No.	Frequency (MHz)	Reading (dBuV)	Correct Factor (dB/m)	Result (dBuV/m)	Limit (dBuV/m)	Margin (dB)	Remark
1	5450.400	45.54	6.15	51.69	54.00	-2.31	AVG
2	5460.000	42.85	6.16	49.01	54.00	-4.99	AVG

Note:1.Result (dBuV/m) = Correct Factor (dB/m) + Reading(dBuV).

2.Correction factor (dB/m) = Antenna Factor (dB/m) + Cable loss (dB) – Pre-Amplifier gain (dB).

3.When the peak results are less than average limit, so not need to evaluate the average.

Standard:	FCC Part 15.407	Test Distance:	3 m
Test item:	Band edge		
Frequency:	5610 MHz		
Mode:	Mode 10		
Ant.Polar.:	Horizontal		

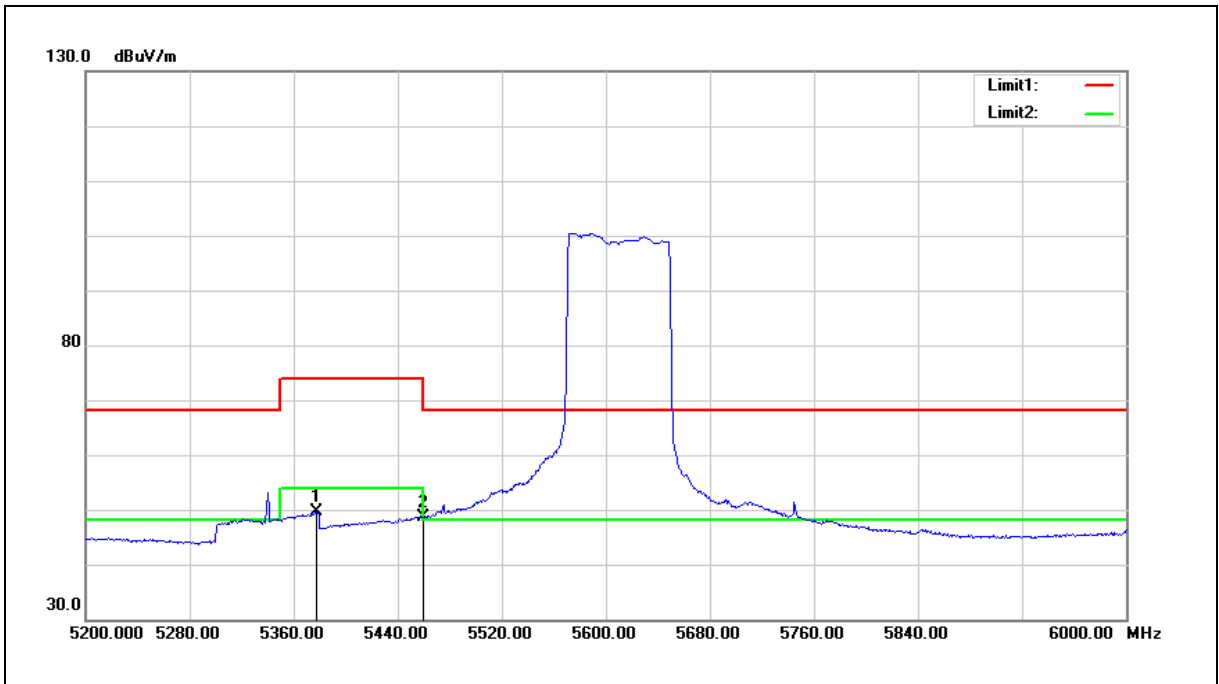

No.	Frequency (MHz)	Reading (dBuV)	Correct Factor (dB/m)	Result (dBuV/m)	Limit (dBuV/m)	Margin (dB)	Remark
1	5377.600	43.65	6.07	49.72	54.00	-4.28	AVG
2	5460.000	42.46	6.16	48.62	54.00	-5.38	AVG

Note:1.Result (dBuV/m) = Correct Factor (dB/m) + Reading(dBuV).

2.Correction factor (dB/m) = Antenna Factor (dB/m) + Cable loss (dB) – Pre-Amplifier gain (dB).

3.When the peak results are less than average limit, so not need to evaluate the average.

Standard:	FCC Part 15.407	Test Distance:	3 m
Test item:	Band edge		
Frequency:	5610 MHz		
Mode:	Mode 10		
Ant.Polar.:	Vertical		

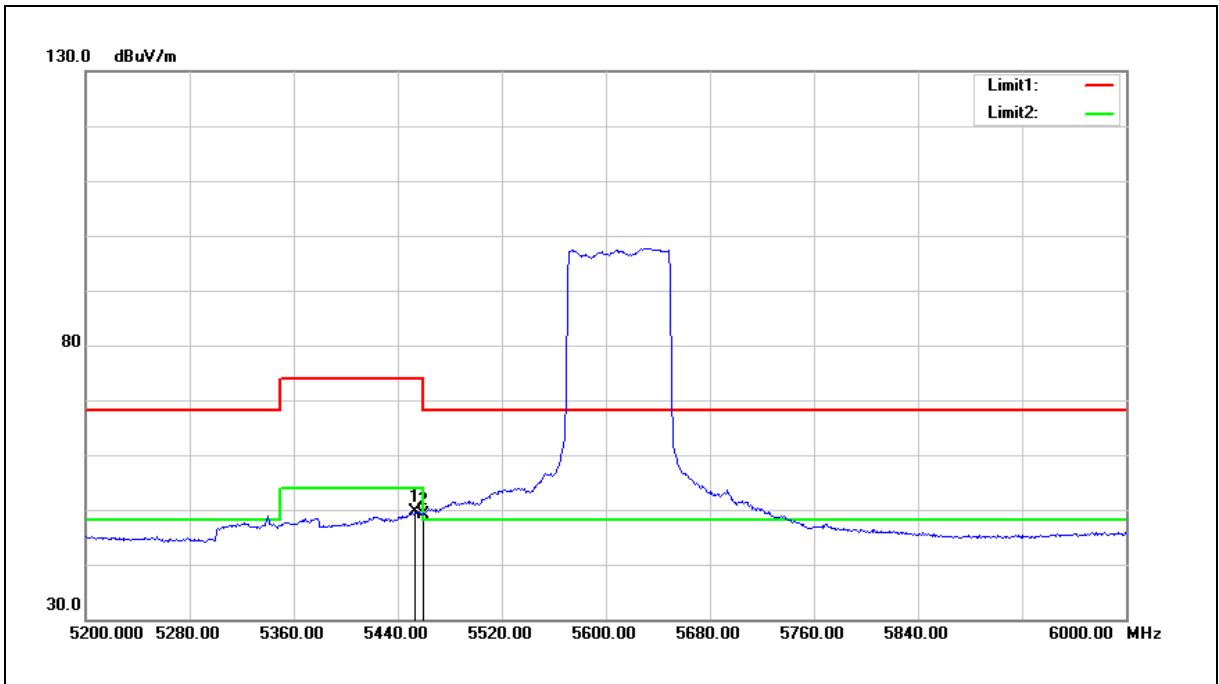

No.	Frequency (MHz)	Reading (dBuV)	Correct Factor (dB/m)	Result (dBuV/m)	Limit (dBuV/m)	Margin (dB)	Remark
1	5453.600	43.44	6.15	49.59	54.00	-4.41	AVG
2	5460.000	43.06	6.16	49.22	54.00	-4.78	AVG

Note:1.Result (dBuV/m) = Correct Factor (dB/m) + Reading(dBuV).

2.Correction factor (dB/m) = Antenna Factor (dB/m) + Cable loss (dB) – Pre-Amplifier gain (dB).

3.When the peak results are less than average limit, so not need to evaluate the average.

Standard:	FCC Part 15.407	Test Distance:	3 m
Test item:	Band edge		
Frequency:	5690 MHz		
Mode:	Mode 10		
Ant.Polar.:	Horizontal		

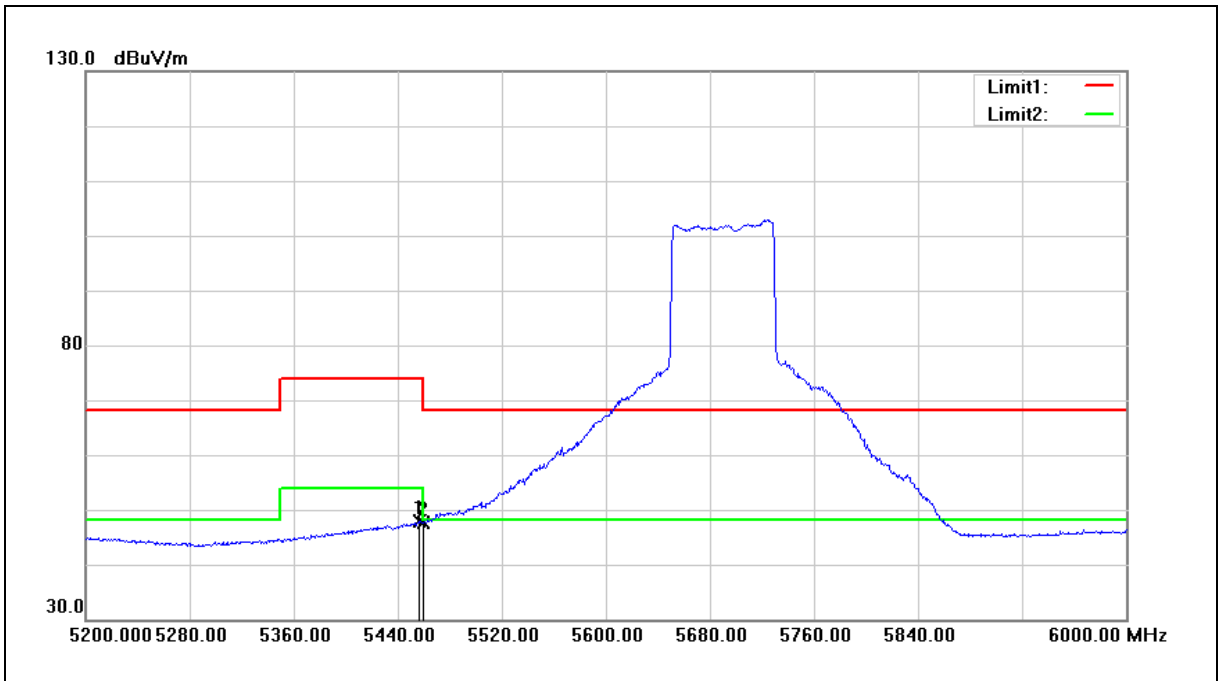

No.	Frequency (MHz)	Reading (dBuV)	Correct Factor (dB/m)	Result (dBuV/m)	Limit (dBuV/m)	Margin (dB)	Remark
1	5456.000	41.75	6.13	47.88	54.00	-6.12	AVG
2	5460.000	41.41	6.14	47.55	54.00	-6.45	AVG

- Note:1.Result (dBuV/m) = Correct Factor (dB/m) + Reading(dBuV).
 2.Correction factor (dB/m) = Antenna Factor (dB/m) + Cable loss (dB) – Pre-Amplifier gain (dB).
 3.When the peak results are less than average limit, so not need to evaluate the average.

Standard:	FCC Part 15.407	Test Distance:	3 m
Test item:	Band edge		
Frequency:	5690 MHz		
Mode:	Mode 10		
Ant.Polar.:	Vertical		

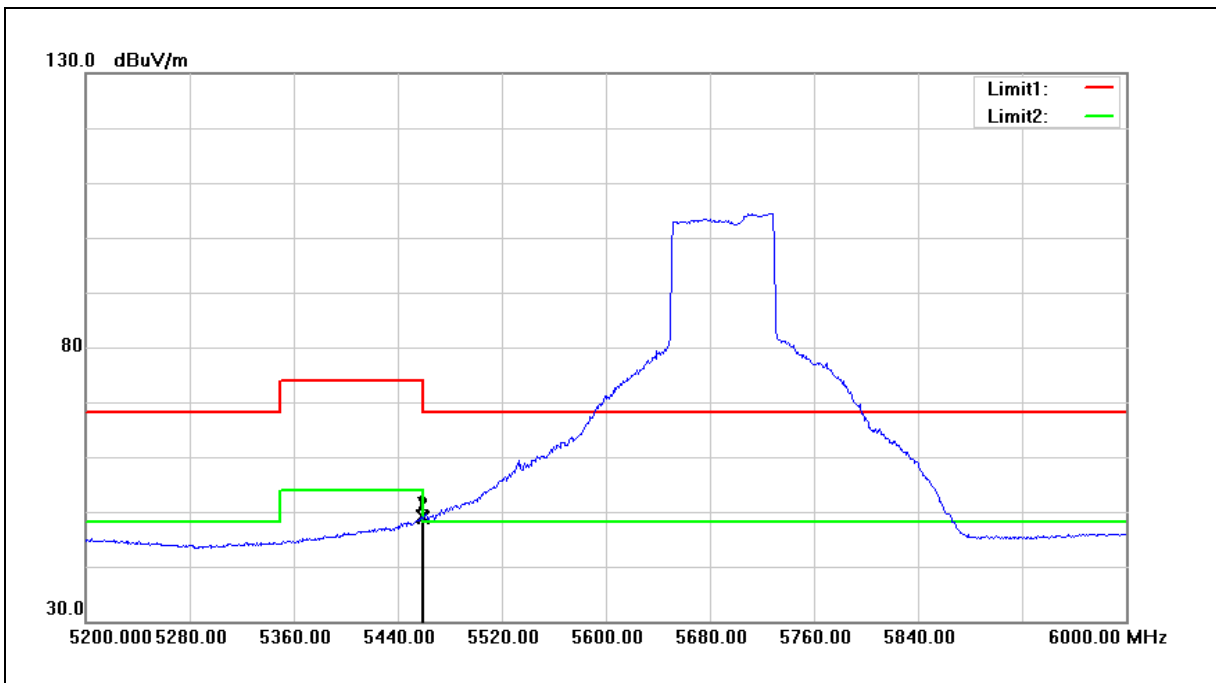

No.	Frequency (MHz)	Reading (dBuV)	Correct Factor (dB/m)	Result (dBuV/m)	Limit (dBuV/m)	Margin (dB)	Remark
1	5458.400	43.00	6.14	49.14	54.00	-4.86	AVG
2	5460.000	42.77	6.14	48.91	54.00	-5.09	AVG

- Note:1.Result (dBuV/m) = Correct Factor (dB/m) + Reading(dBuV).
 2.Correction factor (dB/m) = Antenna Factor (dB/m) + Cable loss (dB) – Pre-Amplifier gain (dB).
 3.When the peak results are less than average limit, so not need to evaluate the average.

Beamforming on

Below 1 GHz

Standard:	FCC Part 15.407	Test Distance:	3 m
Test item:	Radiated Emission		
Frequency:	5500 MHz		
Mode:	Mode 2		
Ant.Polar.:	Horizontal		

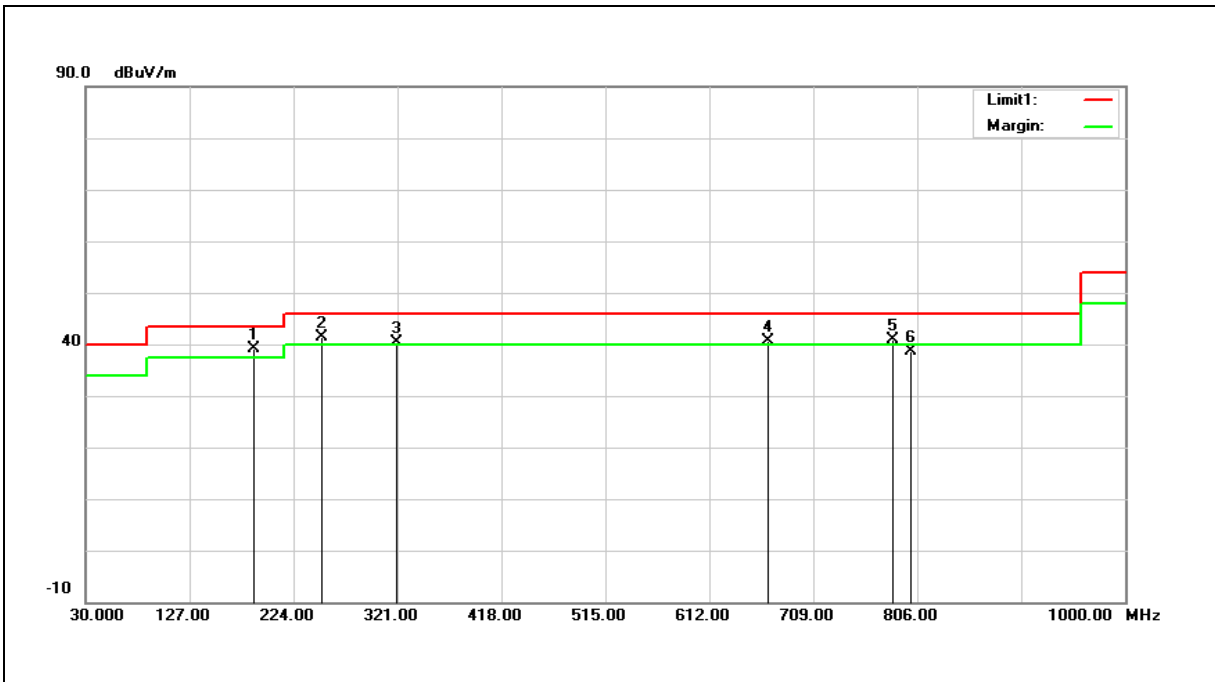

No.	Frequency (MHz)	Reading (dBUV)	Correct Factor (dB/m)	Result (dBUV/m)	Limit (dBUV/m)	Margin (dB)	Remark
1	187.1400	51.76	-12.65	39.11	43.50	-4.39	QP
2	250.1900	52.64	-11.36	41.28	46.00	-4.72	QP
3	320.0300	49.42	-9.11	40.31	46.00	-5.69	QP
4	666.3200	41.85	-1.29	40.56	46.00	-5.44	QP
5	783.6900	40.34	0.66	41.00	46.00	-5.00	QP
6	800.1800	37.91	0.81	38.72	46.00	-7.28	QP

Note:1.Result (dBUV/m) = Correct Factor (dB/m) + Reading(dBUV).

2.Correction factor (dB/m) = Antenna Factor (dB/m) + Cable loss (dB) – Pre-Amplifier gain (dB).

3.When the peak results are less than average limit, so not need to evaluate the average.

Standard:	FCC Part 15.407	Test Distance:	3 m
Test item:	Radiated Emission		
Frequency:	5500 MHz		
Mode:	Mode 2		
Ant.Polar.:	Vertical		

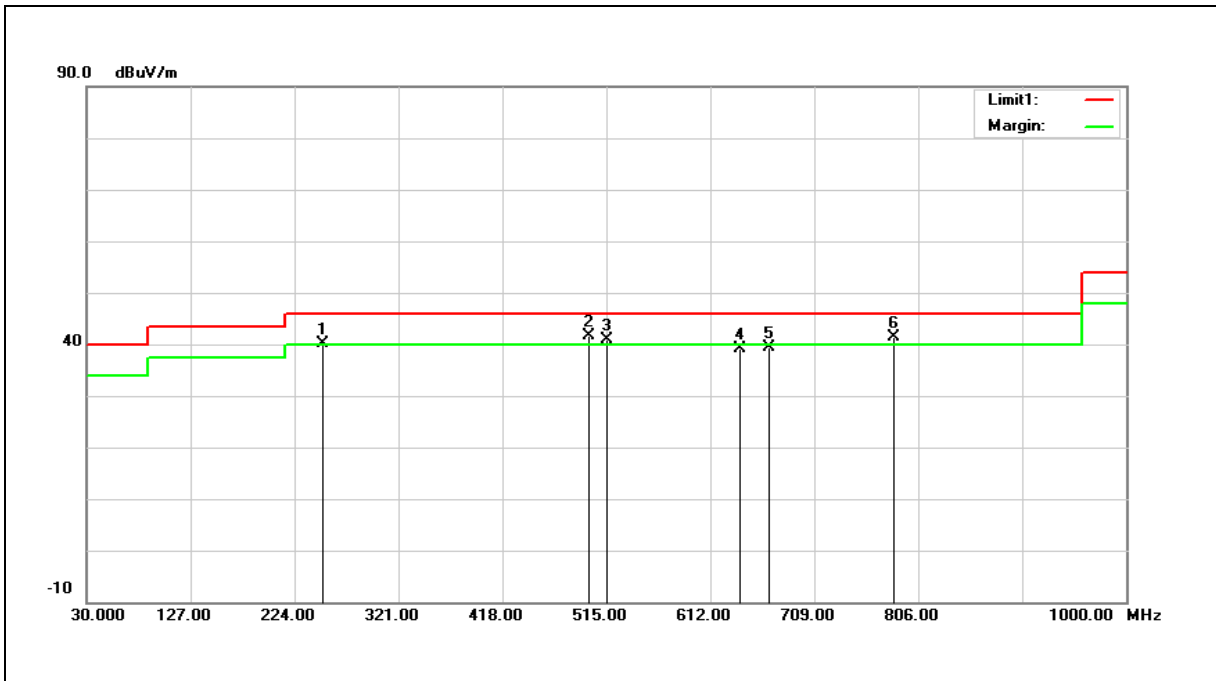

No.	Frequency (MHz)	Reading (dBuV)	Correct Factor (dB/m)	Result (dBuV/m)	Limit (dBuV/m)	Margin (dB)	Remark
1	250.1900	51.56	-11.36	40.20	46.00	-5.80	QP
2	498.5100	46.23	-4.54	41.69	46.00	-4.31	QP
3	515.0000	45.18	-4.29	40.89	46.00	-5.11	QP
4	640.1300	40.70	-1.62	39.08	46.00	-6.92	QP
5	666.3200	40.56	-1.29	39.27	46.00	-6.73	QP
6	783.6900	40.83	0.66	41.49	46.00	-4.51	QP

Note:1.Result (dBuV/m) = Correct Factor (dB/m) + Reading(dBuV).

2.Correction factor (dB/m) = Antenna Factor (dB/m) + Cable loss (dB) – Pre-Amplifier gain (dB).

3.When the peak results are less than average limit, so not need to evaluate the average.

Above 1 GHz

Standard:	FCC Part 15.407	Test Distance:	3 m
Test item:	Harmonic		
Frequency:	5180 MHz		
Mode:	Mode 8		
Ant.Polar.:	Horizontal		

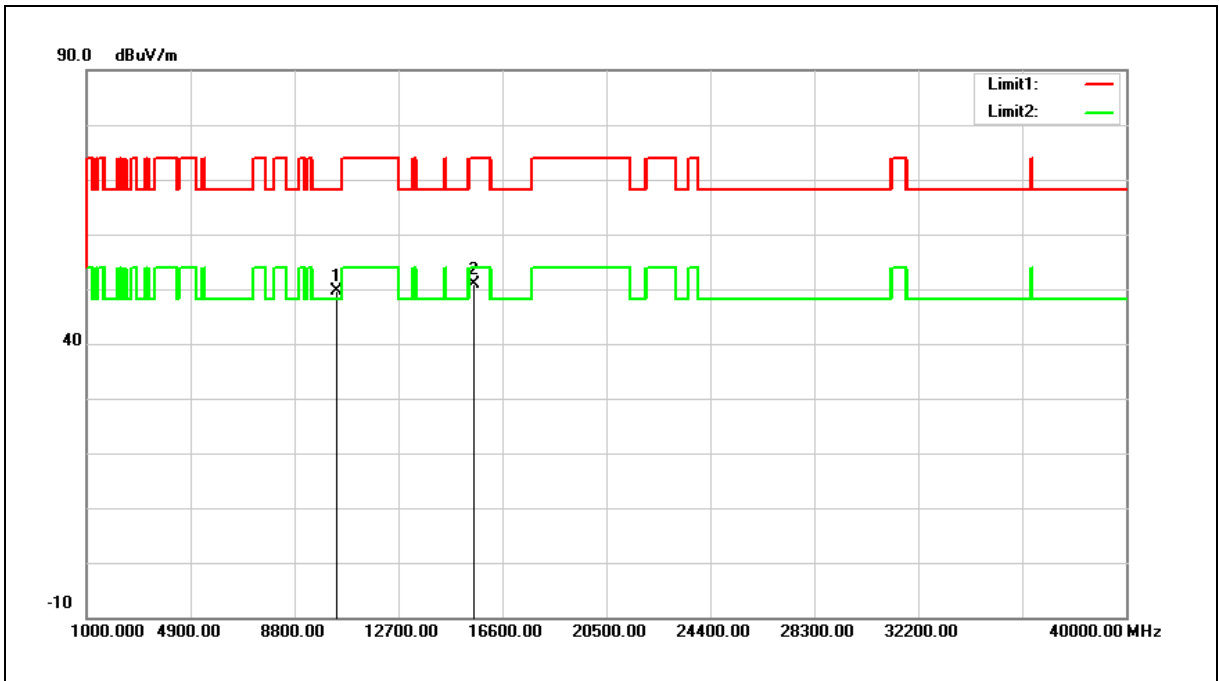

No.	Frequency (MHz)	Reading (dBuV)	Correct Factor (dB/m)	Result (dBuV/m)	Limit (dBuV/m)	Margin (dB)	Remark
1	10360.000	32.75	16.87	49.62	68.20	-18.58	peak
2	15540.000	32.47	18.51	50.98	74.00	-23.02	peak

Note:1.Result (dBuV/m) = Correct Factor (dB/m) + Reading(dBuV).

2.Correction factor (dB/m) = Antenna Factor (dB/m) + Cable loss (dB) – Pre-Amplifier gain (dB).

3.When the peak results are less than average limit, so not need to evaluate the average.

Standard:	FCC Part 15.407	Test Distance:	3 m
Test item:	Harmonic		
Frequency:	5180 MHz		
Mode:	Mode 8		
Ant.Polar.:	Vertical		

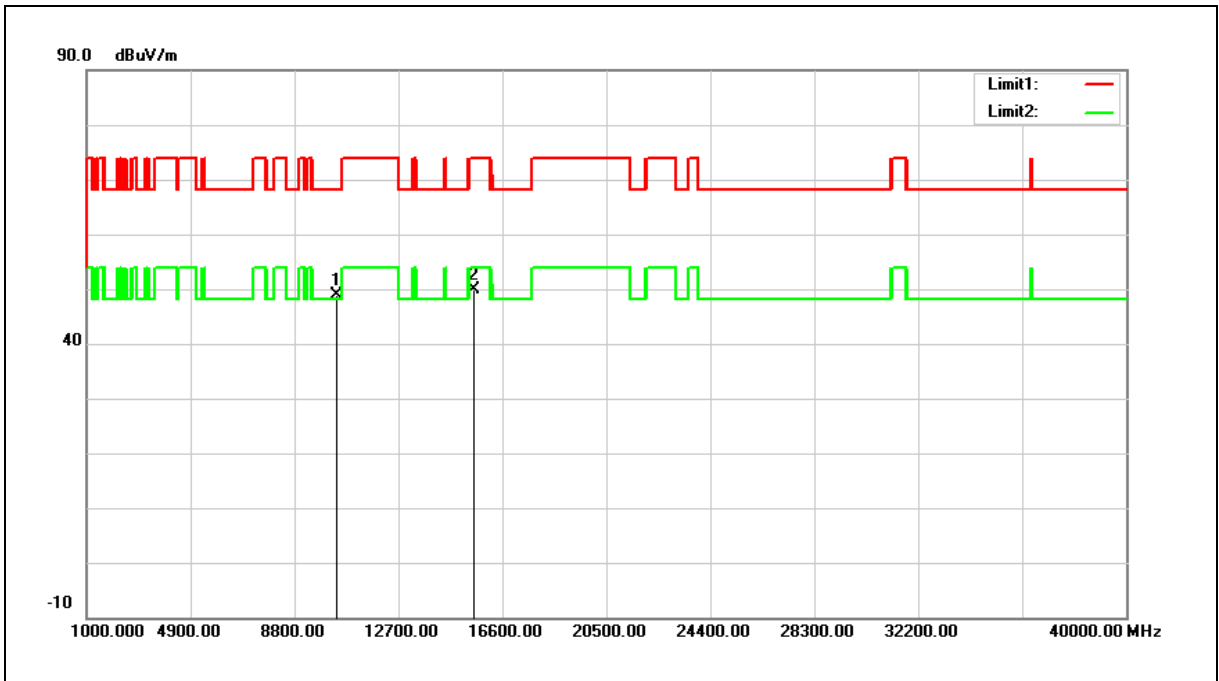

No.	Frequency (MHz)	Reading (dBuV)	Correct Factor (dB/m)	Result (dBuV/m)	Limit (dBuV/m)	Margin (dB)	Remark
1	10360.000	31.96	16.87	48.83	68.20	-19.37	peak
2	15540.000	31.40	18.51	49.91	74.00	-24.09	peak

Note:1.Result (dBuV/m) = Correct Factor (dB/m) + Reading(dBuV).

2.Correction factor (dB/m) = Antenna Factor (dB/m) + Cable loss (dB) – Pre-Amplifier gain (dB).

3.When the peak results are less than average limit, so not need to evaluate the average.

Standard:	FCC Part 15.407	Test Distance:	3 m
Test item:	Harmonic		
Frequency:	5200 MHz		
Mode:	Mode 8		
Ant.Polar.:	Horizontal		

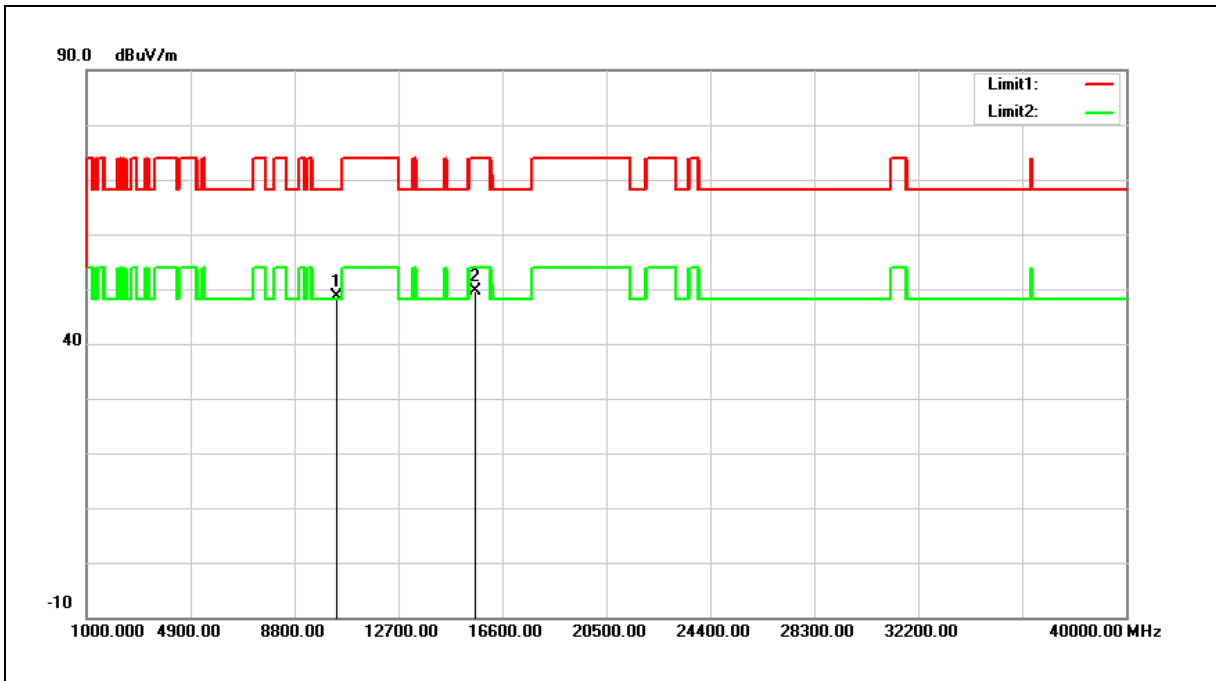

No.	Frequency (MHz)	Reading (dBuV)	Correct Factor (dB/m)	Result (dBuV/m)	Limit (dBuV/m)	Margin (dB)	Remark
1	10400.000	31.64	16.95	48.59	68.20	-19.61	peak
2	15600.000	31.24	18.35	49.59	74.00	-24.41	peak

Note:1.Result (dBuV/m) = Correct Factor (dB/m) + Reading(dBuV).

2.Correction factor (dB/m) = Antenna Factor (dB/m) + Cable loss (dB) – Pre-Amplifier gain (dB).

3.When the peak results are less than average limit, so not need to evaluate the average.

Standard:	FCC Part 15.407	Test Distance:	3 m
Test item:	Harmonic		
Frequency:	5200 MHz		
Mode:	Mode 8		
Ant.Polar.:	Vertical		

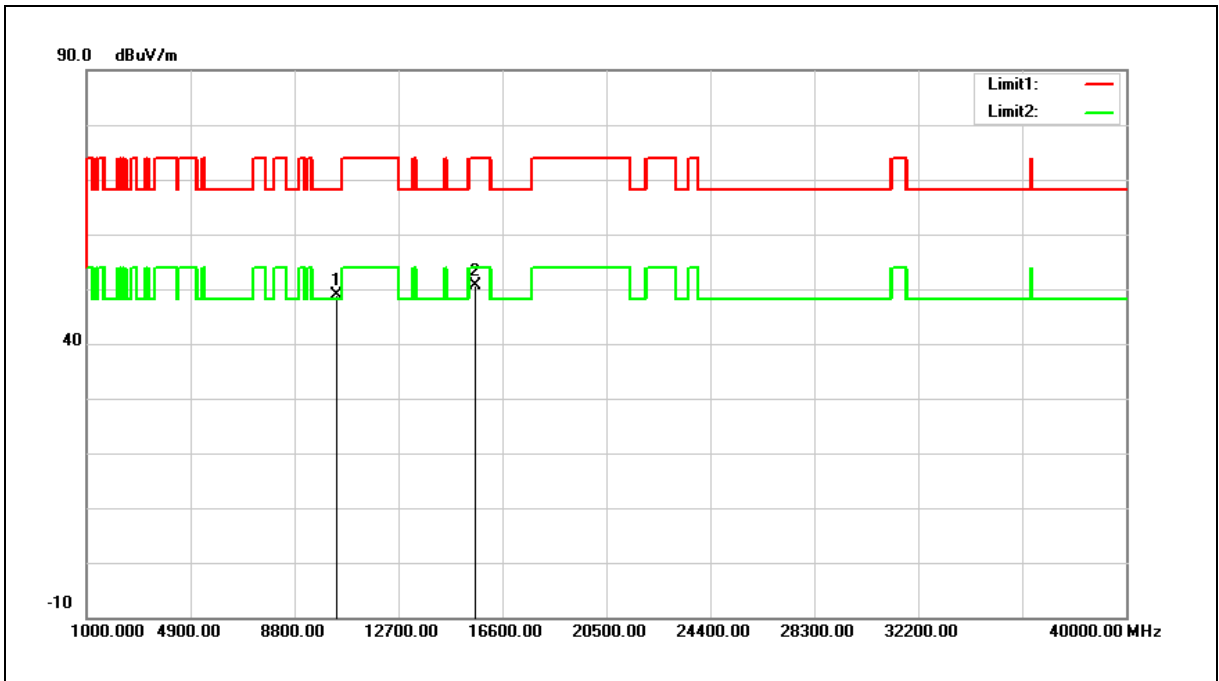

No.	Frequency (MHz)	Reading (dBuV)	Correct Factor (dB/m)	Result (dBuV/m)	Limit (dBuV/m)	Margin (dB)	Remark
1	10400.000	31.92	16.95	48.87	68.20	-19.33	peak
2	15600.000	32.40	18.35	50.75	74.00	-23.25	peak

Note:1.Result (dBuV/m) = Correct Factor (dB/m) + Reading(dBuV).

2.Correction factor (dB/m) = Antenna Factor (dB/m) + Cable loss (dB) – Pre-Amplifier gain (dB).

3.When the peak results are less than average limit, so not need to evaluate the average.

Standard:	FCC Part 15.407	Test Distance:	3 m
Test item:	Harmonic		
Frequency:	5240 MHz		
Mode:	Mode 8		
Ant.Polar.:	Horizontal		

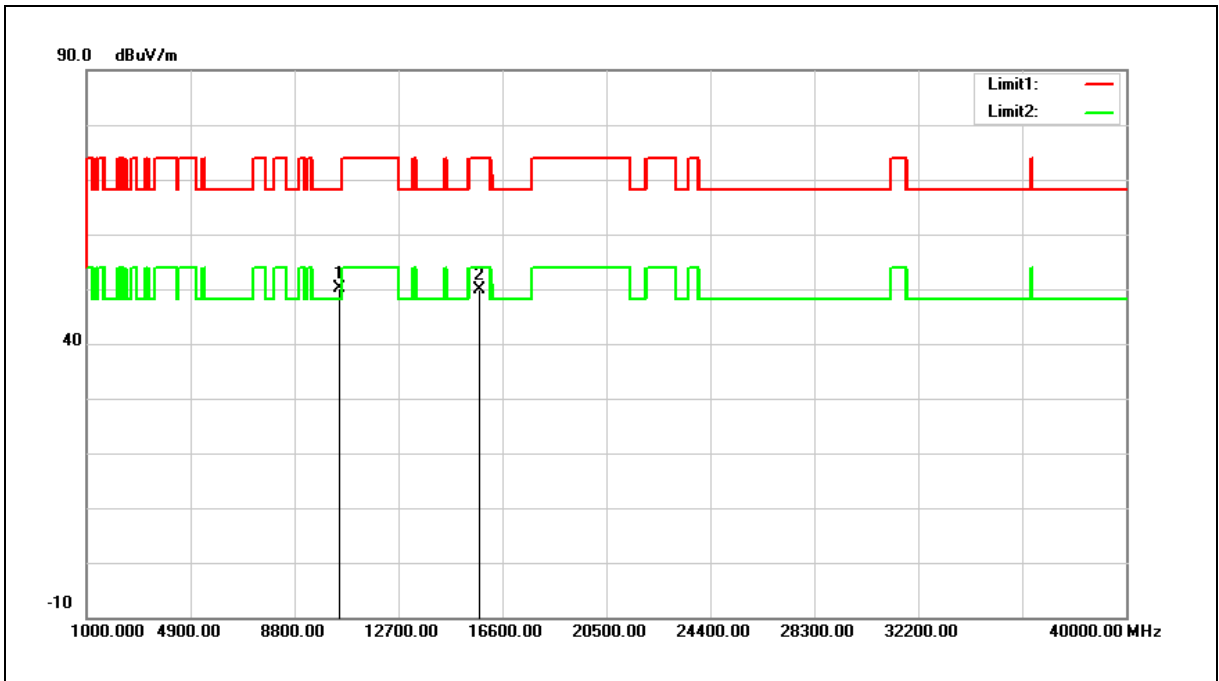

No.	Frequency (MHz)	Reading (dBuV)	Correct Factor (dB/m)	Result (dBuV/m)	Limit (dBuV/m)	Margin (dB)	Remark
1	10480.000	32.91	17.12	50.03	68.20	-18.17	peak
2	15720.000	31.95	18.00	49.95	74.00	-24.05	peak

Note:1.Result (dBuV/m) = Correct Factor (dB/m) + Reading(dBuV).

2.Correction factor (dB/m) = Antenna Factor (dB/m) + Cable loss (dB) – Pre-Amplifier gain (dB).

3.When the peak results are less than average limit, so not need to evaluate the average.

Standard:	FCC Part 15.407	Test Distance:	3 m
Test item:	Harmonic		
Frequency:	5240 MHz		
Mode:	Mode 8		
Ant.Polar.:	Vertical		

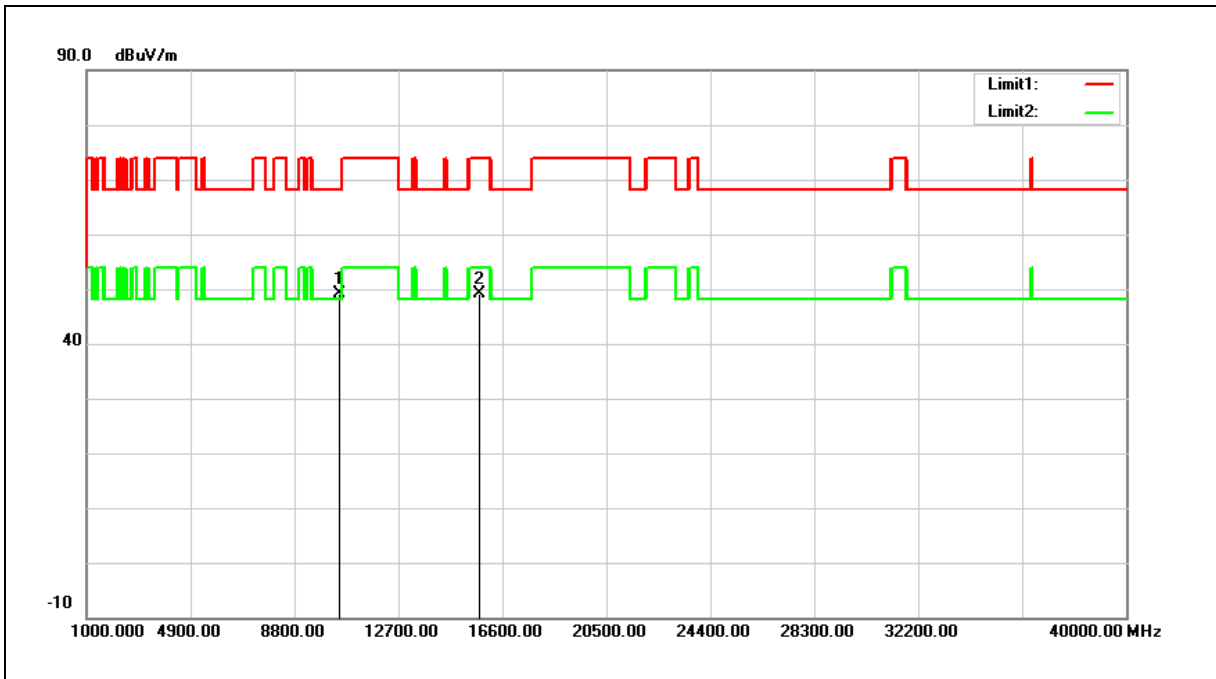

No.	Frequency (MHz)	Reading (dBuV)	Correct Factor (dB/m)	Result (dBuV/m)	Limit (dBuV/m)	Margin (dB)	Remark
1	10480.000	32.03	17.12	49.15	68.20	-19.05	peak
2	15720.000	31.17	18.00	49.17	74.00	-24.83	peak

Note:1.Result (dBuV/m) = Correct Factor (dB/m) + Reading(dBuV).

2.Correction factor (dB/m) = Antenna Factor (dB/m) + Cable loss (dB) – Pre-Amplifier gain (dB).

3.When the peak results are less than average limit, so not need to evaluate the average.

Standard:	FCC Part 15.407	Test Distance:	3 m
Test item:	Harmonic		
Frequency:	5260 MHz		
Mode:	Mode 8		
Ant.Polar.:	Horizontal		

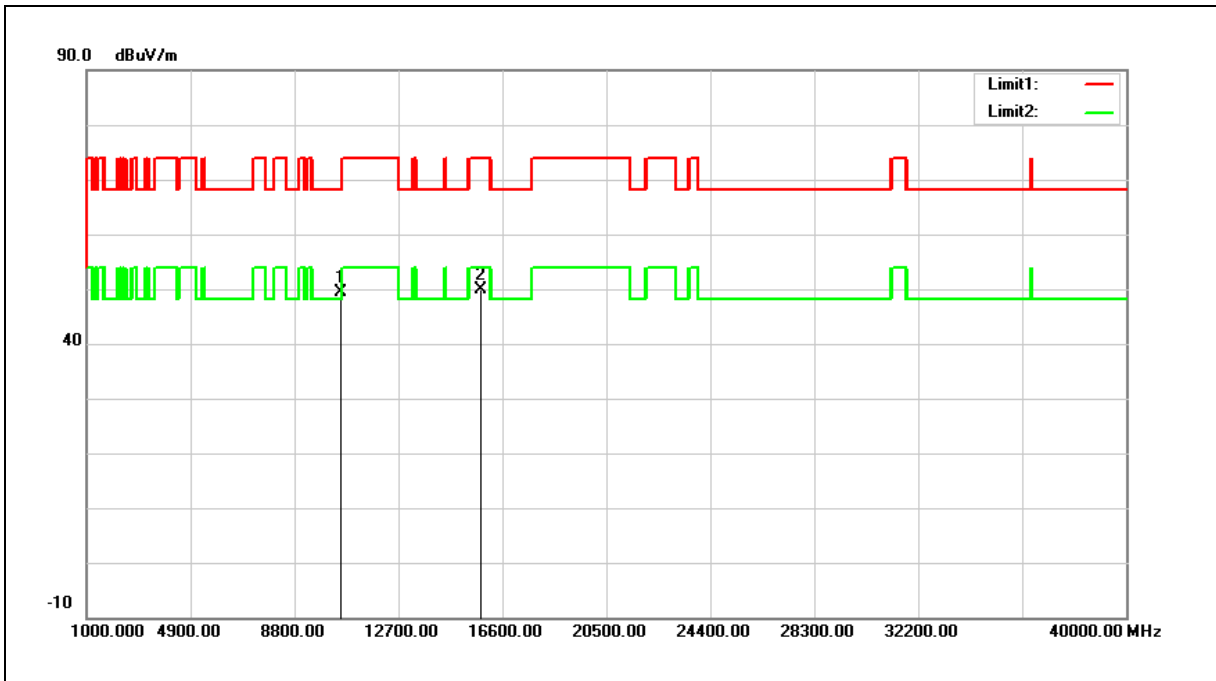

No.	Frequency (MHz)	Reading (dBuV)	Correct Factor (dB/m)	Result (dBuV/m)	Limit (dBuV/m)	Margin (dB)	Remark
1	10520.000	32.19	17.20	49.39	68.20	-18.81	peak
2	15780.000	31.94	17.82	49.76	74.00	-24.24	peak

Note:1.Result (dBuV/m) = Correct Factor (dB/m) + Reading(dBuV).

2.Correction factor (dB/m) = Antenna Factor (dB/m) + Cable loss (dB) – Pre-Amplifier gain (dB).

3.When the peak results are less than average limit, so not need to evaluate the average.

Standard:	FCC Part 15.407	Test Distance:	3 m
Test item:	Harmonic		
Frequency:	5260 MHz		
Mode:	Mode 8		
Ant.Polar.:	Vertical		

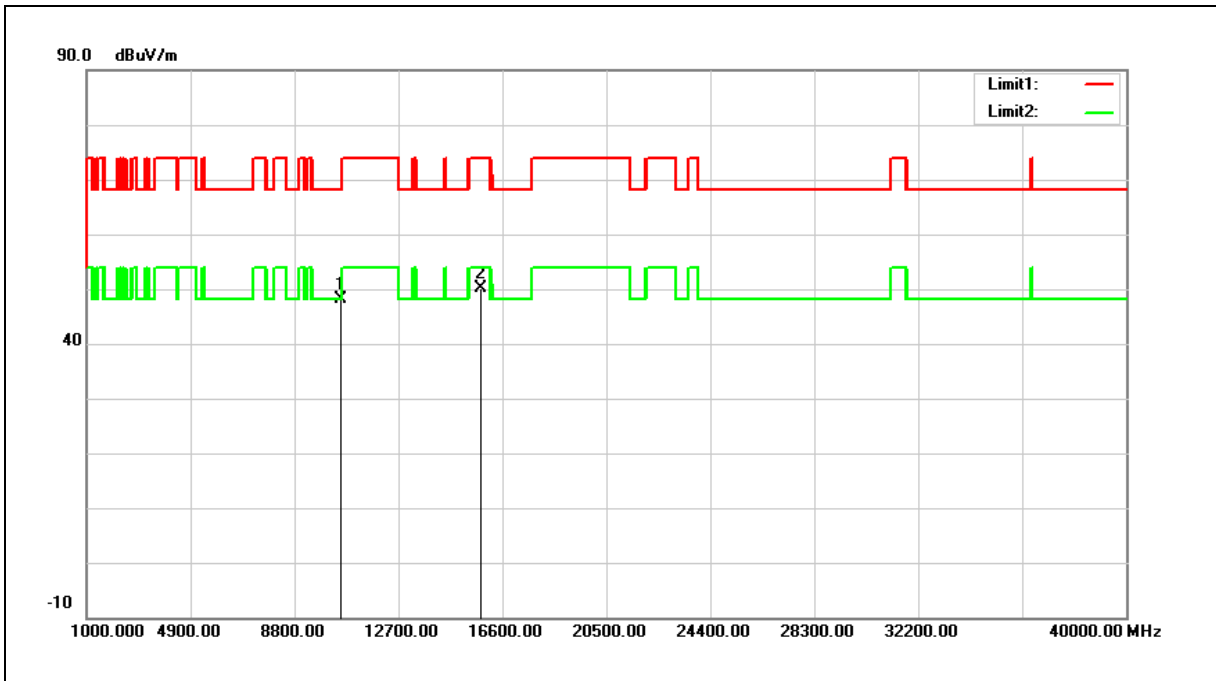

No.	Frequency (MHz)	Reading (dBuV)	Correct Factor (dB/m)	Result (dBuV/m)	Limit (dBuV/m)	Margin (dB)	Remark
1	10520.000	31.02	17.20	48.22	68.20	-19.98	peak
2	15780.000	32.25	17.82	50.07	74.00	-23.93	peak

Note:1.Result (dBuV/m) = Correct Factor (dB/m) + Reading(dBuV).

2.Correction factor (dB/m) = Antenna Factor (dB/m) + Cable loss (dB) – Pre-Amplifier gain (dB).

3.When the peak results are less than average limit, so not need to evaluate the average.

Standard:	FCC Part 15.407	Test Distance:	3 m
Test item:	Harmonic		
Frequency:	5280 MHz		
Mode:	Mode 8		
Ant.Polar.:	Horizontal		

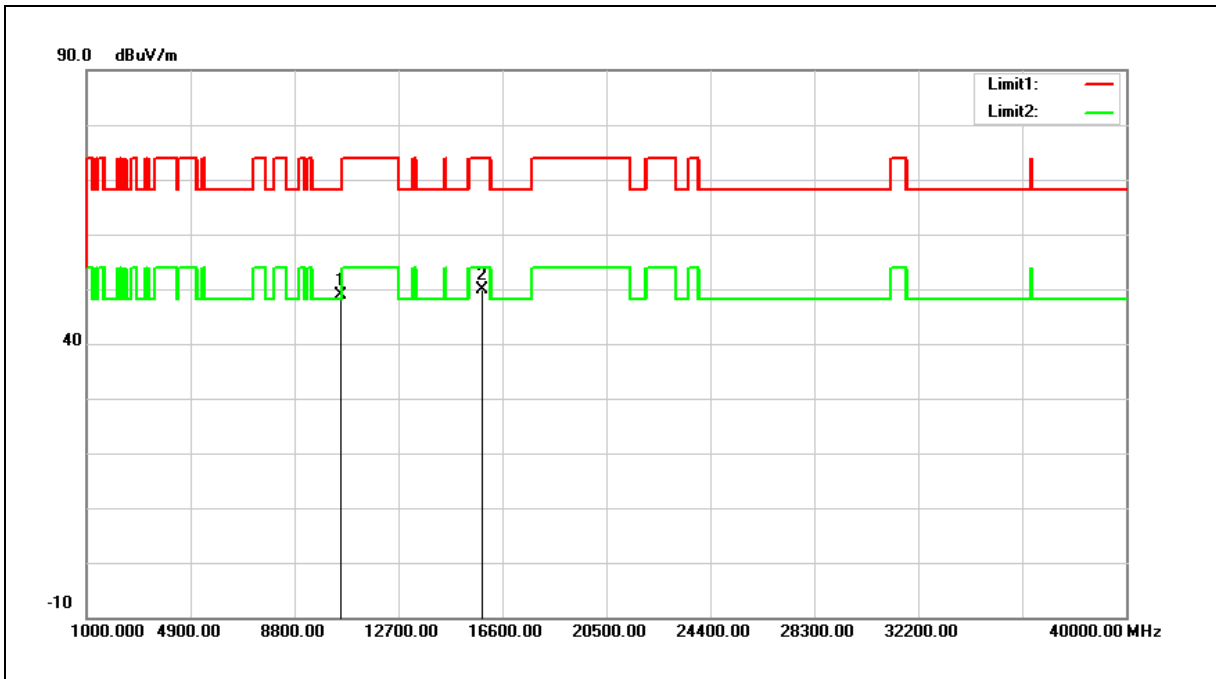

No.	Frequency (MHz)	Reading (dBuV)	Correct Factor (dB/m)	Result (dBuV/m)	Limit (dBuV/m)	Margin (dB)	Remark
1	10560.000	31.66	17.29	48.95	68.20	-19.25	peak
2	15840.000	32.32	17.65	49.97	74.00	-24.03	peak

Note:1.Result (dBuV/m) = Correct Factor (dB/m) + Reading(dBuV).

2.Correction factor (dB/m) = Antenna Factor (dB/m) + Cable loss (dB) – Pre-Amplifier gain (dB).

3.When the peak results are less than average limit, so not need to evaluate the average.

Standard:	FCC Part 15.407	Test Distance:	3 m
Test item:	Harmonic		
Frequency:	5280 MHz		
Mode:	Mode 8		
Ant.Polar.:	Vertical		

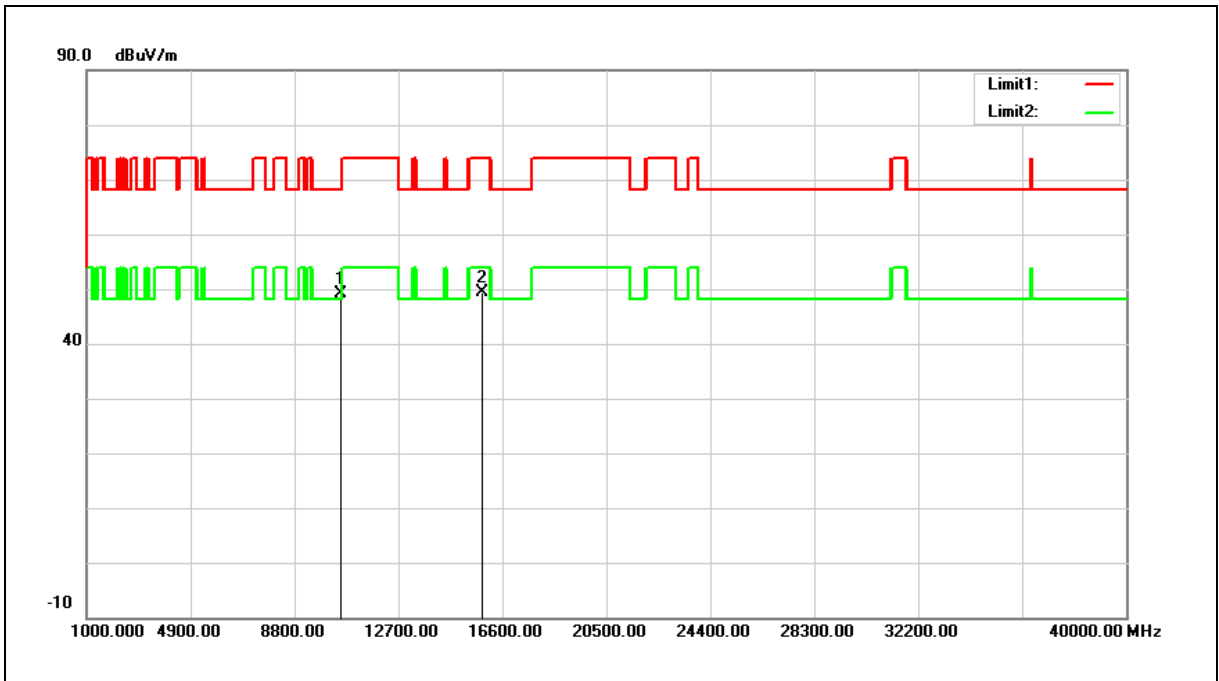

No.	Frequency (MHz)	Reading (dBuV)	Correct Factor (dB/m)	Result (dBuV/m)	Limit (dBuV/m)	Margin (dB)	Remark
1	10560.000	31.87	17.29	49.16	68.20	-19.04	peak
2	15840.000	31.67	17.65	49.32	74.00	-24.68	peak

Note:1.Result (dBuV/m) = Correct Factor (dB/m) + Reading(dBuV).

2.Correction factor (dB/m) = Antenna Factor (dB/m) + Cable loss (dB) – Pre-Amplifier gain (dB).

3.When the peak results are less than average limit, so not need to evaluate the average.

Standard:	FCC Part 15.407	Test Distance:	3 m
Test item:	Harmonic		
Frequency:	5320 MHz		
Mode:	Mode 8		
Ant.Polar.:	Horizontal		

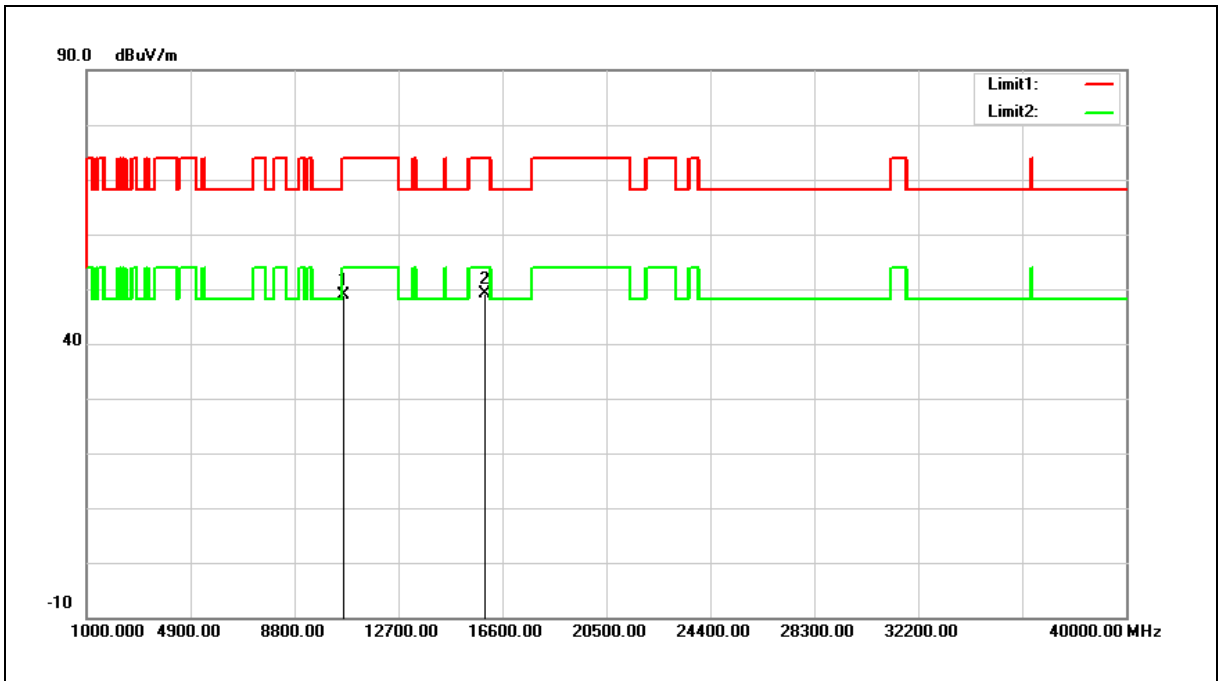

No.	Frequency (MHz)	Reading (dBuV)	Correct Factor (dB/m)	Result (dBuV/m)	Limit (dBuV/m)	Margin (dB)	Remark
1	10640.000	31.36	17.48	48.84	74.00	-25.16	peak
2	15960.000	31.86	17.31	49.17	74.00	-24.83	peak

Note:1.Result (dBuV/m) = Correct Factor (dB/m) + Reading(dBuV).

2.Correction factor (dB/m) = Antenna Factor (dB/m) + Cable loss (dB) – Pre-Amplifier gain (dB).

3.When the peak results are less than average limit, so not need to evaluate the average.

Standard:	FCC Part 15.407	Test Distance:	3 m
Test item:	Harmonic		
Frequency:	5320 MHz		
Mode:	Mode 8		
Ant.Polar.:	Vertical		

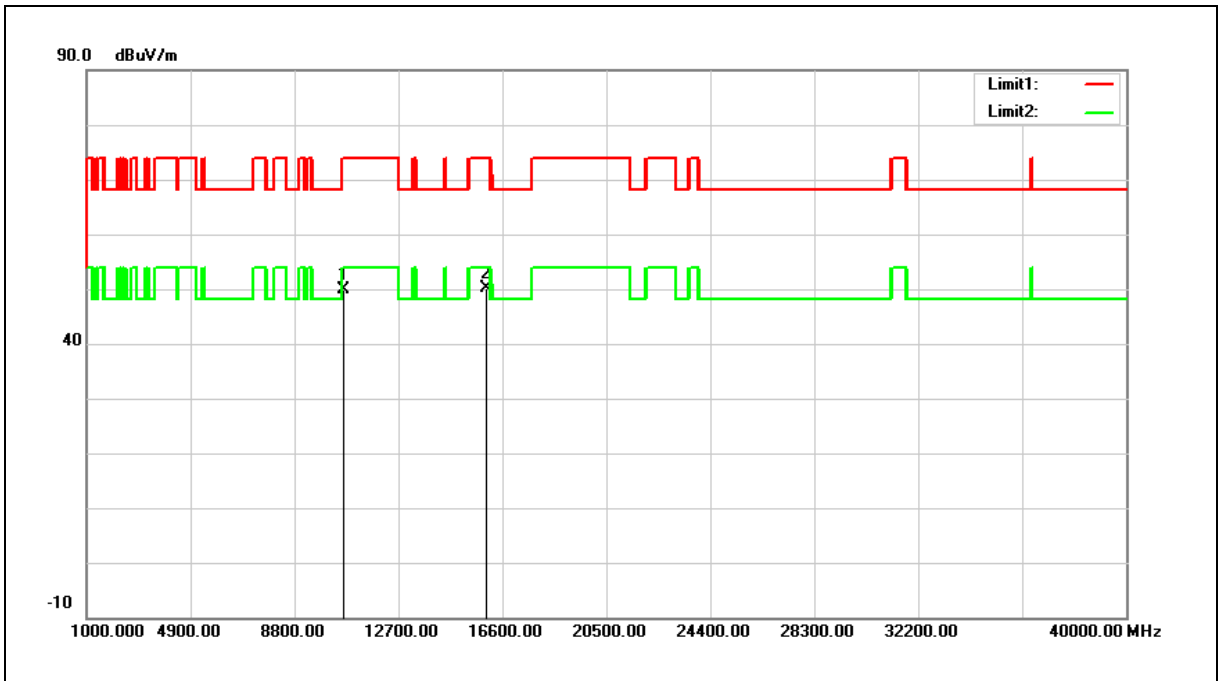

No.	Frequency (MHz)	Reading (dBuV)	Correct Factor (dB/m)	Result (dBuV/m)	Limit (dBuV/m)	Margin (dB)	Remark
1	10640.000	32.38	17.48	49.86	74.00	-24.14	peak
2	15960.000	32.86	17.31	50.17	74.00	-23.83	peak

Note:1.Result (dBuV/m) = Correct Factor (dB/m) + Reading(dBuV).

2.Correction factor (dB/m) = Antenna Factor (dB/m) + Cable loss (dB) – Pre-Amplifier gain (dB).

3.When the peak results are less than average limit, so not need to evaluate the average.

Standard:	FCC Part 15.407	Test Distance:	3 m
Test item:	Harmonic		
Frequency:	5500 MHz		
Mode:	Mode 8		
Ant.Polar.:	Horizontal		

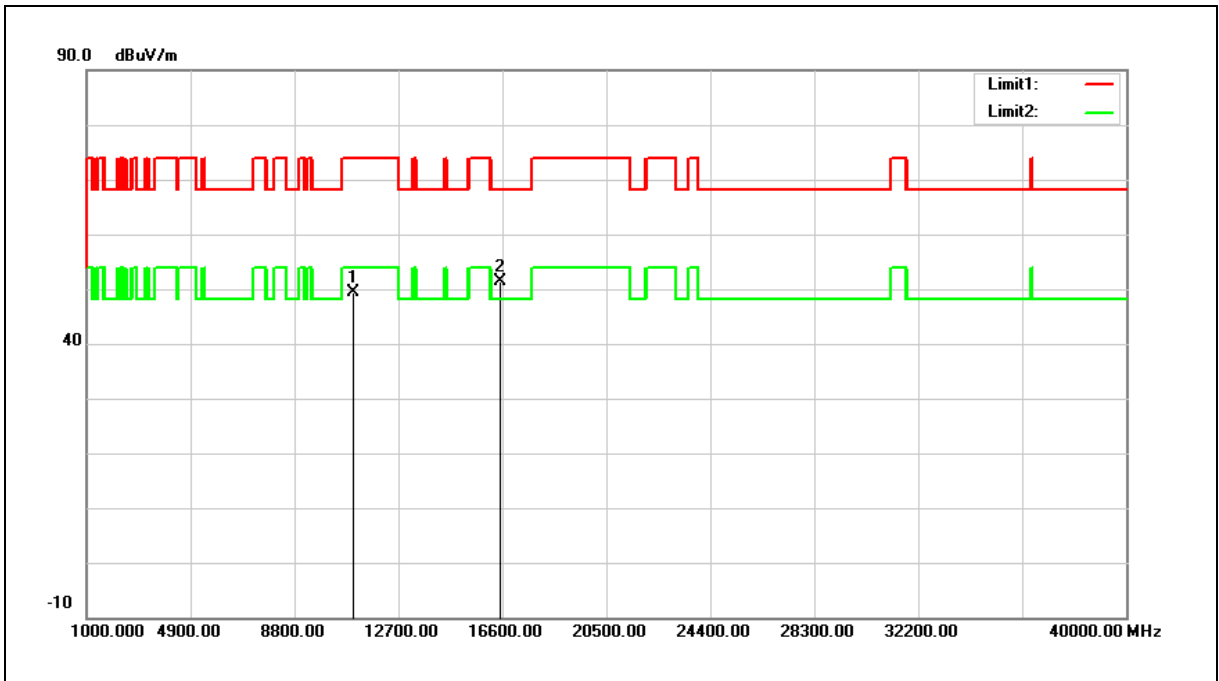

No.	Frequency (MHz)	Reading (dBuV)	Correct Factor (dB/m)	Result (dBuV/m)	Limit (dBuV/m)	Margin (dB)	Remark
1	11000.000	31.20	18.29	49.49	74.00	-24.51	peak
2	16500.000	31.70	19.79	51.49	68.20	-16.71	peak

Note:1.Result (dBuV/m) = Correct Factor (dB/m) + Reading(dBuV).

2.Correction factor (dB/m) = Antenna Factor (dB/m) + Cable loss (dB) – Pre-Amplifier gain (dB).

3.When the peak results are less than average limit, so not need to evaluate the average.

Standard:	FCC Part 15.407	Test Distance:	3 m
Test item:	Harmonic		
Frequency:	5500 MHz		
Mode:	Mode 8		
Ant.Polar.:	Vertical		

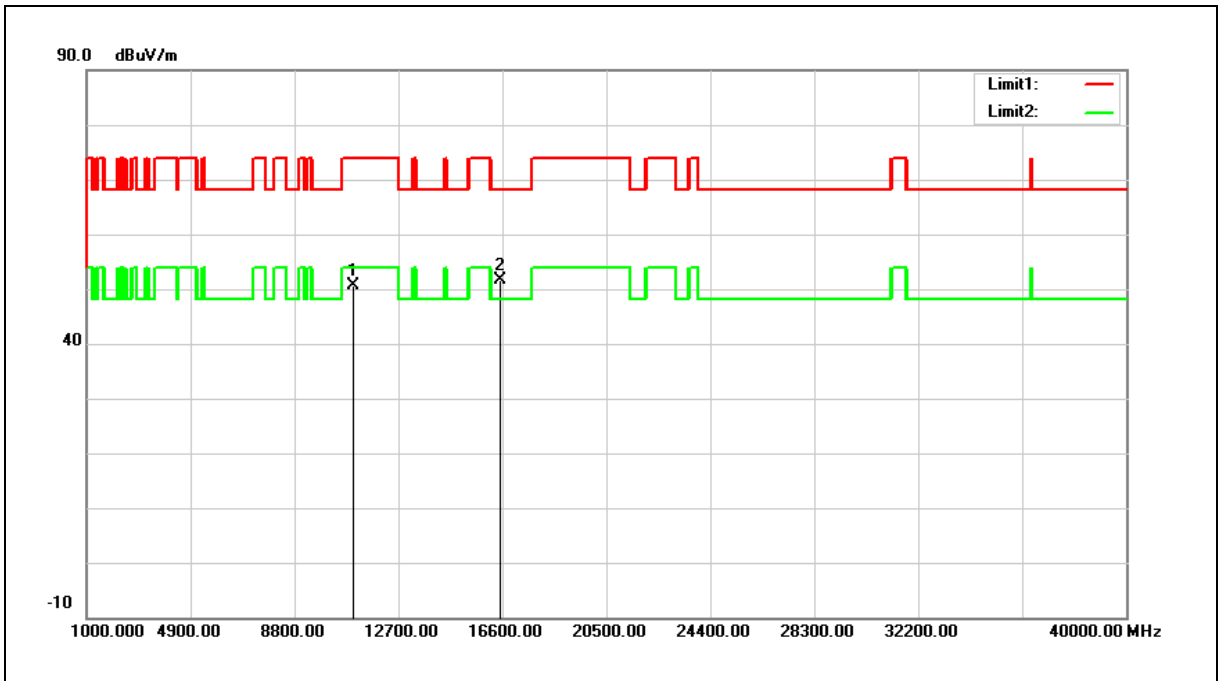

No.	Frequency (MHz)	Reading (dBuV)	Correct Factor (dB/m)	Result (dBuV/m)	Limit (dBuV/m)	Margin (dB)	Remark
1	11000.000	32.46	18.29	50.75	74.00	-23.25	peak
2	16500.000	31.74	19.79	51.53	68.20	-16.67	peak

Note:1.Result (dBuV/m) = Correct Factor (dB/m) + Reading(dBuV).

2.Correction factor (dB/m) = Antenna Factor (dB/m) + Cable loss (dB) – Pre-Amplifier gain (dB).

3.When the peak results are less than average limit, so not need to evaluate the average.

Standard:	FCC Part 15.407	Test Distance:	3 m
Test item:	Harmonic		
Frequency:	5560 MHz		
Mode:	Mode 8		
Ant.Polar.:	Horizontal		

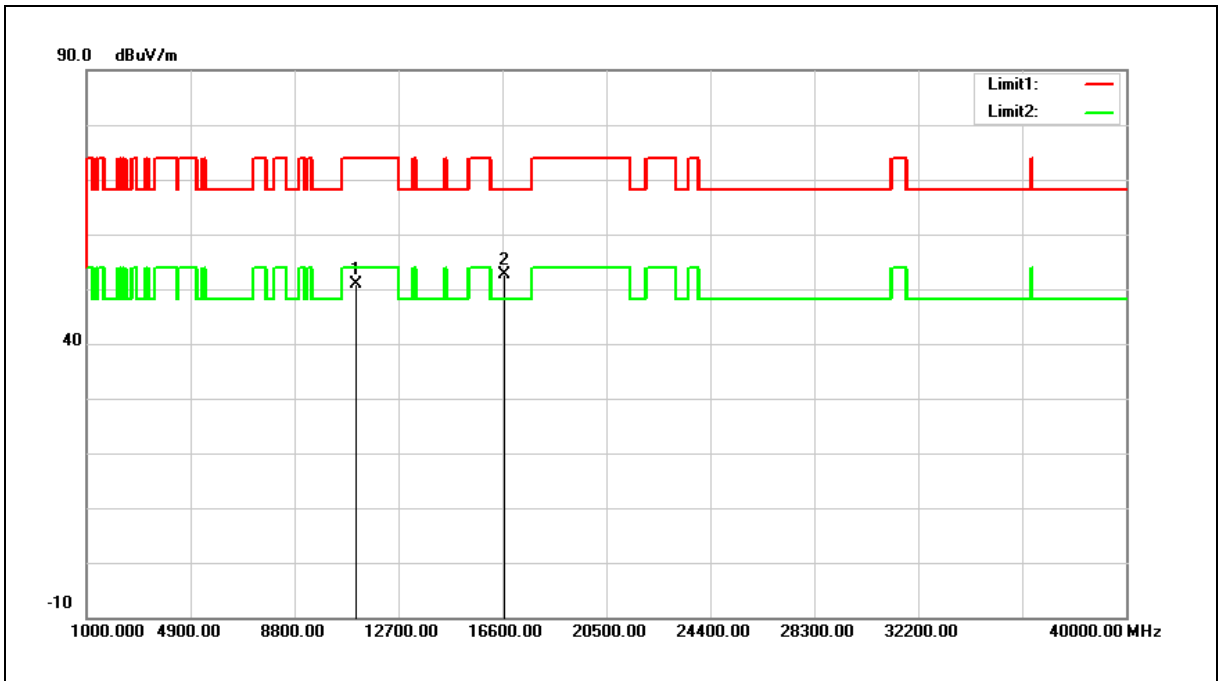

No.	Frequency (MHz)	Reading (dBuV)	Correct Factor (dB/m)	Result (dBuV/m)	Limit (dBuV/m)	Margin (dB)	Remark
1	11120.000	32.58	18.34	50.92	74.00	-23.08	peak
2	16680.000	31.61	20.94	52.55	68.20	-15.65	peak

Note:1.Result (dBuV/m) = Correct Factor (dB/m) + Reading(dBuV).

2.Correction factor (dB/m) = Antenna Factor (dB/m) + Cable loss (dB) – Pre-Amplifier gain (dB).

3.When the peak results are less than average limit, so not need to evaluate the average.

Standard:	FCC Part 15.407	Test Distance:	3 m
Test item:	Harmonic		
Frequency:	5560 MHz		
Mode:	Mode 8		
Ant.Polar.:	Vertical		

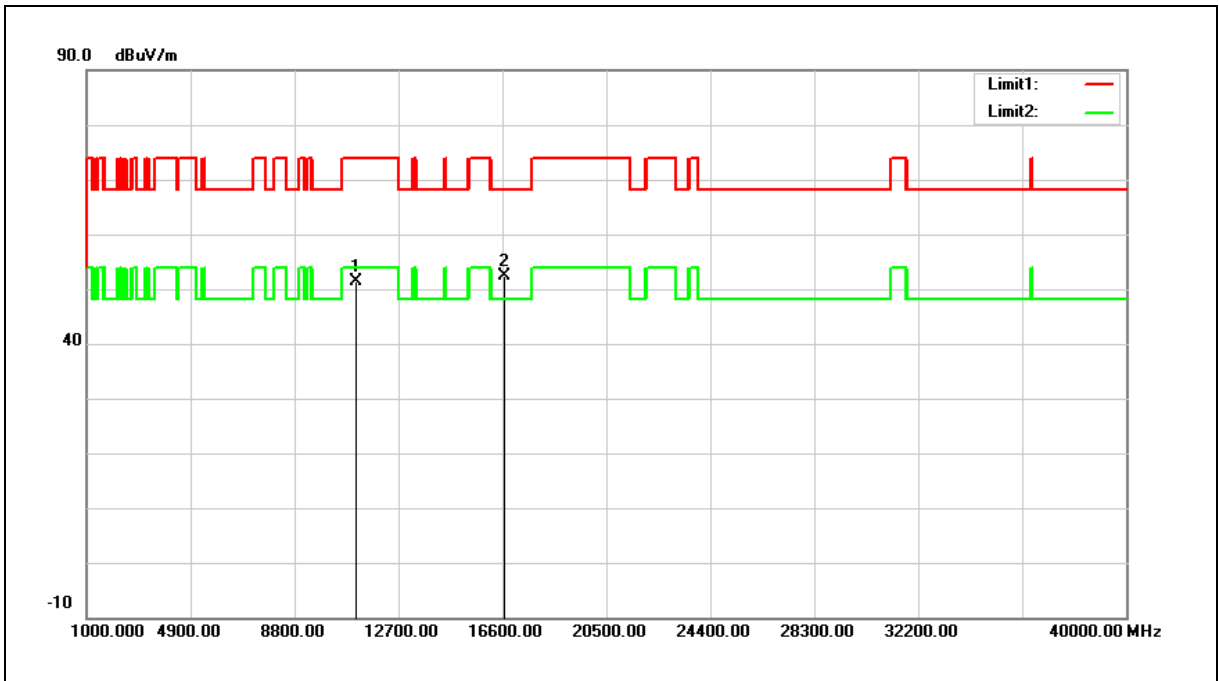

No.	Frequency (MHz)	Reading (dBuV)	Correct Factor (dB/m)	Result (dBuV/m)	Limit (dBuV/m)	Margin (dB)	Remark
1	11120.000	33.03	18.34	51.37	74.00	-22.63	peak
2	16680.000	31.50	20.94	52.44	68.20	-15.76	peak

Note:1.Result (dBuV/m) = Correct Factor (dB/m) + Reading(dBuV).

2.Correction factor (dB/m) = Antenna Factor (dB/m) + Cable loss (dB) – Pre-Amplifier gain (dB).

3.When the peak results are less than average limit, so not need to evaluate the average.

Standard:	FCC Part 15.407	Test Distance:	3 m
Test item:	Harmonic		
Frequency:	5700 MHz		
Mode:	Mode 8		
Ant.Polar.:	Horizontal		

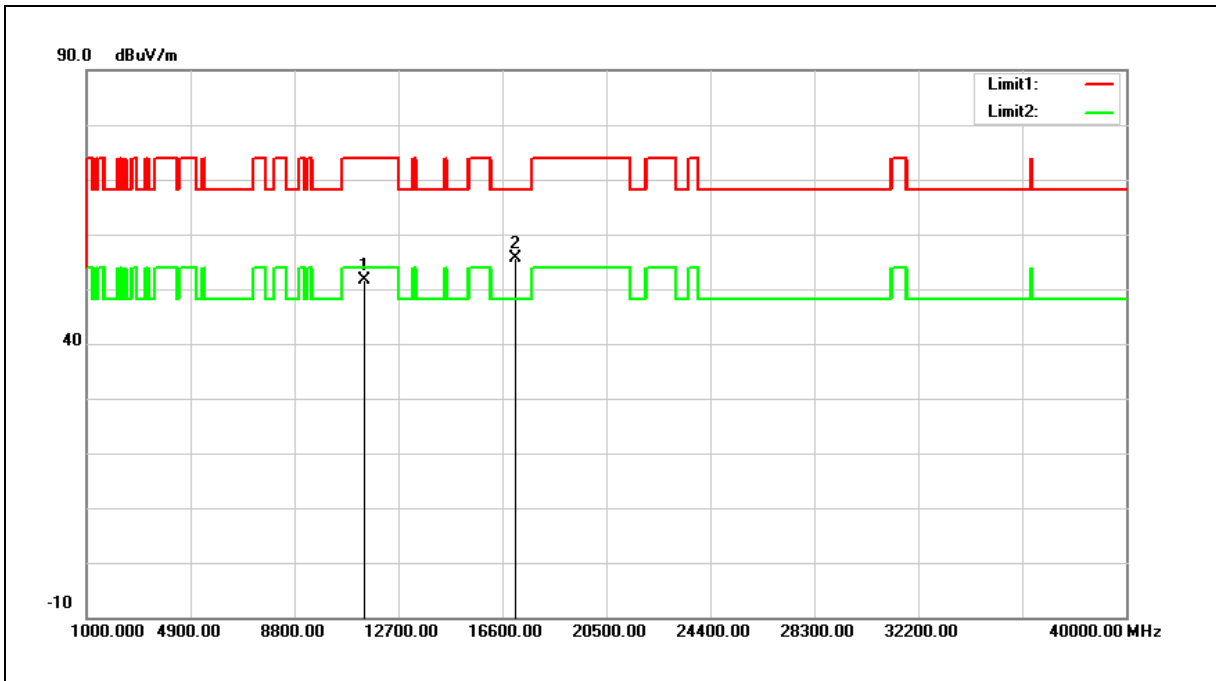

No.	Frequency (MHz)	Reading (dBuV)	Correct Factor (dB/m)	Result (dBuV/m)	Limit (dBuV/m)	Margin (dB)	Remark
1	11400.000	33.11	18.45	51.56	74.00	-22.44	peak
2	17100.000	32.05	23.56	55.61	68.20	-12.59	peak

Note:1.Result (dBuV/m) = Correct Factor (dB/m) + Reading(dBuV).

2.Correction factor (dB/m) = Antenna Factor (dB/m) + Cable loss (dB) – Pre-Amplifier gain (dB).

3.When the peak results are less than average limit, so not need to evaluate the average.

Standard:	FCC Part 15.407	Test Distance:	3 m
Test item:	Harmonic		
Frequency:	5700 MHz		
Mode:	Mode 8		
Ant.Polar.:	Vertical		

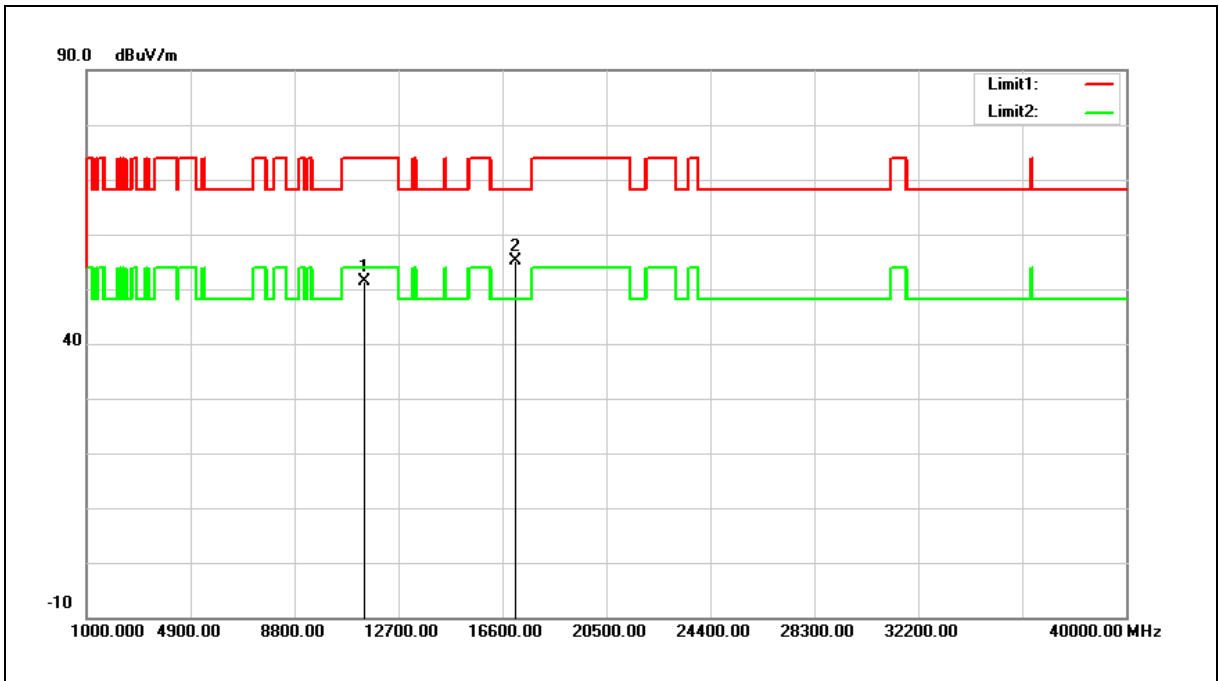

No.	Frequency (MHz)	Reading (dBuV)	Correct Factor (dB/m)	Result (dBuV/m)	Limit (dBuV/m)	Margin (dB)	Remark
1	11400.000	32.90	18.45	51.35	74.00	-22.65	peak
2	17100.000	31.56	23.56	55.12	68.20	-13.08	peak

Note:1.Result (dBuV/m) = Correct Factor (dB/m) + Reading(dBuV).

2.Correction factor (dB/m) = Antenna Factor (dB/m) + Cable loss (dB) – Pre-Amplifier gain (dB).

3.When the peak results are less than average limit, so not need to evaluate the average.

Standard:	FCC Part 15.407	Test Distance:	3 m
Test item:	Harmonic		
Frequency:	5720 MHz		
Mode:	Mode 8		
Ant.Polar.:	Horizontal		

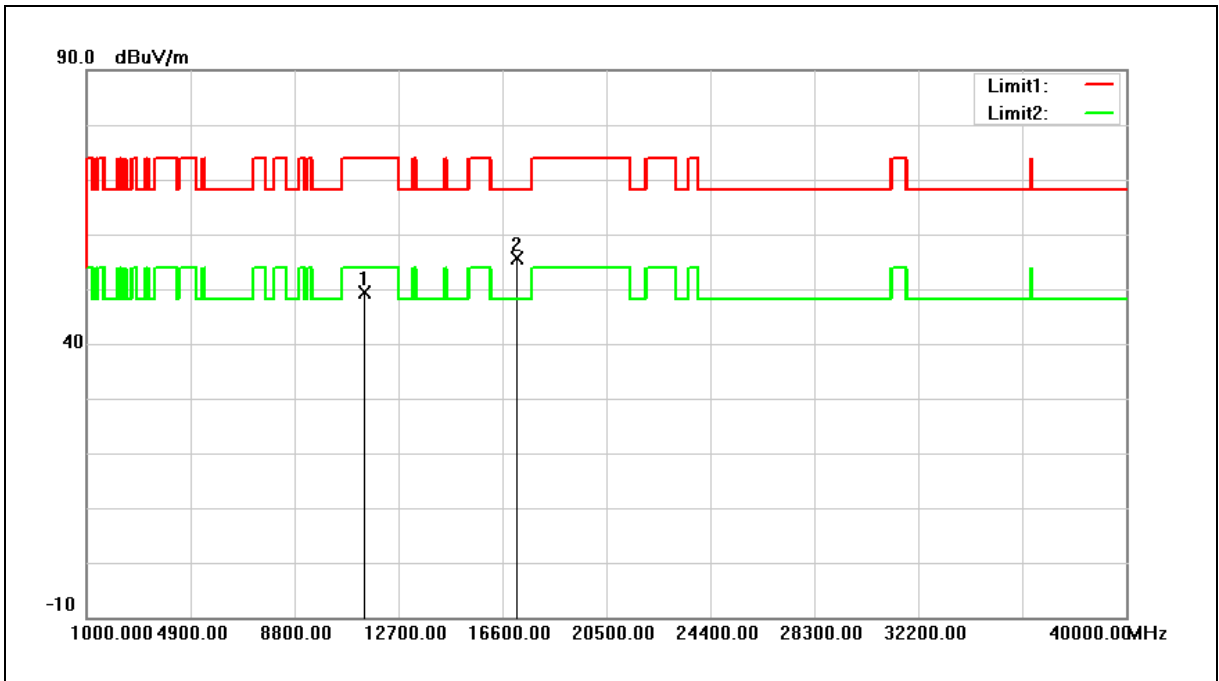

No.	Frequency (MHz)	Reading (dBuV)	Correct Factor (dB/m)	Result (dBuV/m)	Limit (dBuV/m)	Margin (dB)	Remark
1	11440.000	30.89	18.47	49.36	74.00	-24.64	peak
2	17160.000	31.71	23.87	55.58	68.20	-12.62	peak

Note:1.Result (dBuV/m) = Correct Factor (dB/m) + Reading(dBuV).

2.Correction factor (dB/m) = Antenna Factor (dB/m) + Cable loss (dB) – Pre-Amplifier gain (dB).

3.When the peak results are less than average limit, so not need to evaluate the average.

Standard:	FCC Part 15.407	Test Distance:	3 m
Test item:	Harmonic		
Frequency:	5720 MHz		
Mode:	Mode 8		
Ant.Polar.:	Vertical		

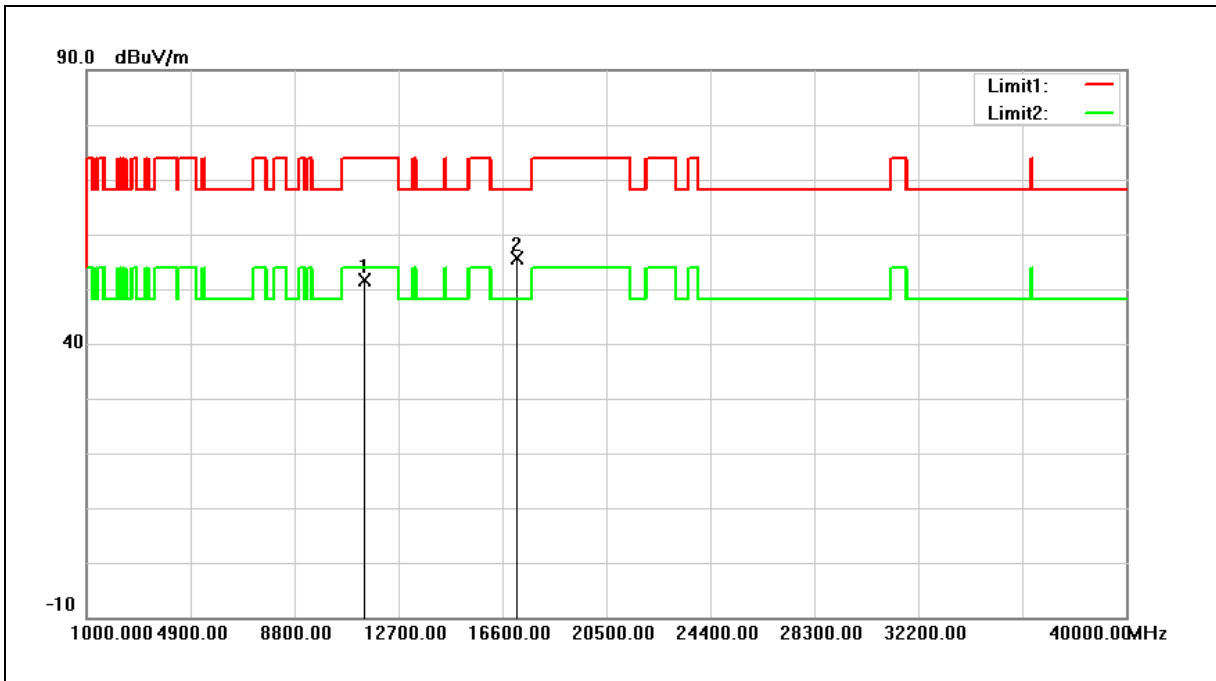

No.	Frequency (MHz)	Reading (dBuV)	Correct Factor (dB/m)	Result (dBuV/m)	Limit (dBuV/m)	Margin (dB)	Remark
1	11440.000	33.13	18.47	51.60	74.00	-22.40	peak
2	17160.000	31.71	23.87	55.58	68.20	-12.62	peak

Note:1.Result (dBuV/m) = Correct Factor (dB/m) + Reading(dBuV).

2.Correction factor (dB/m) = Antenna Factor (dB/m) + Cable loss (dB) – Pre-Amplifier gain (dB).

3.When the peak results are less than average limit, so not need to evaluate the average.

Standard:	FCC Part 15.407	Test Distance:	3 m
Test item:	Harmonic		
Frequency:	5745 MHz		
Mode:	Mode 8		
Ant.Polar.:	Horizontal		

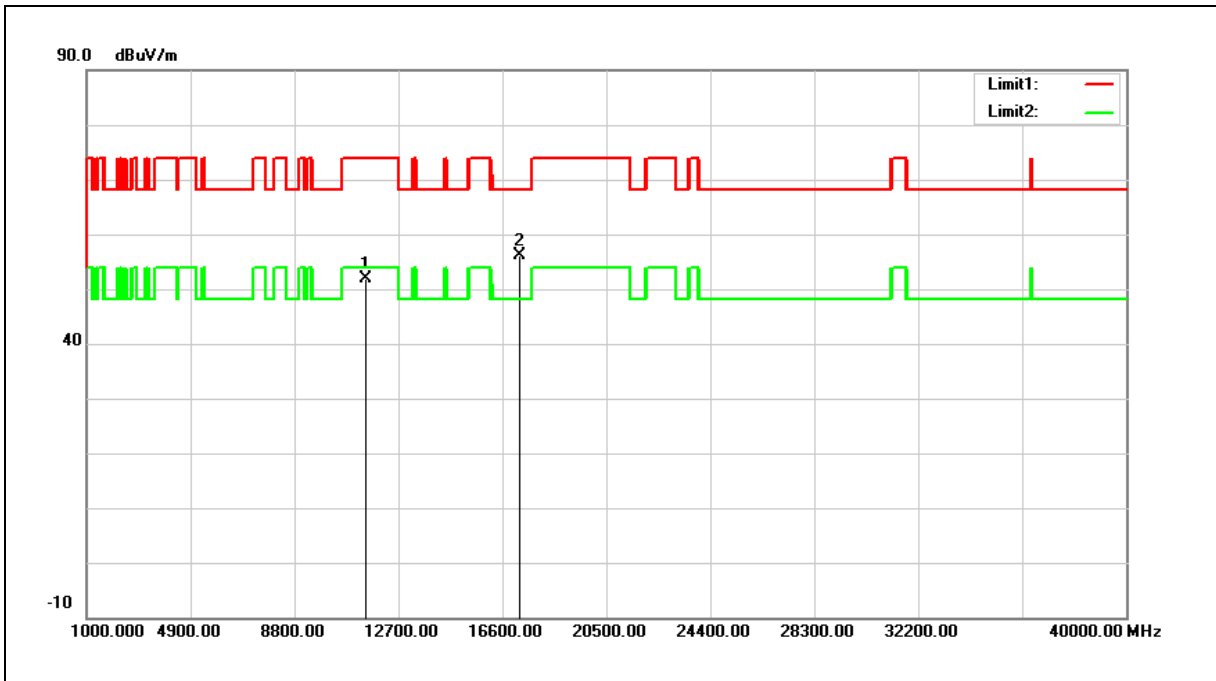

No.	Frequency (MHz)	Reading (dBuV)	Correct Factor (dB/m)	Result (dBuV/m)	Limit (dBuV/m)	Margin (dB)	Remark
1	11490.000	33.47	18.50	51.97	74.00	-22.03	peak
2	17235.000	31.89	24.29	56.18	68.20	-12.02	peak

Note:1.Result (dBuV/m) = Correct Factor (dB/m) + Reading(dBuV).

2.Correction factor (dB/m) = Antenna Factor (dB/m) + Cable loss (dB) – Pre-Amplifier gain (dB).

3.When the peak results are less than average limit, so not need to evaluate the average.

Standard:	FCC Part 15.407	Test Distance:	3 m
Test item:	Harmonic		
Frequency:	5745 MHz		
Mode:	Mode 8		
Ant.Polar.:	Vertical		

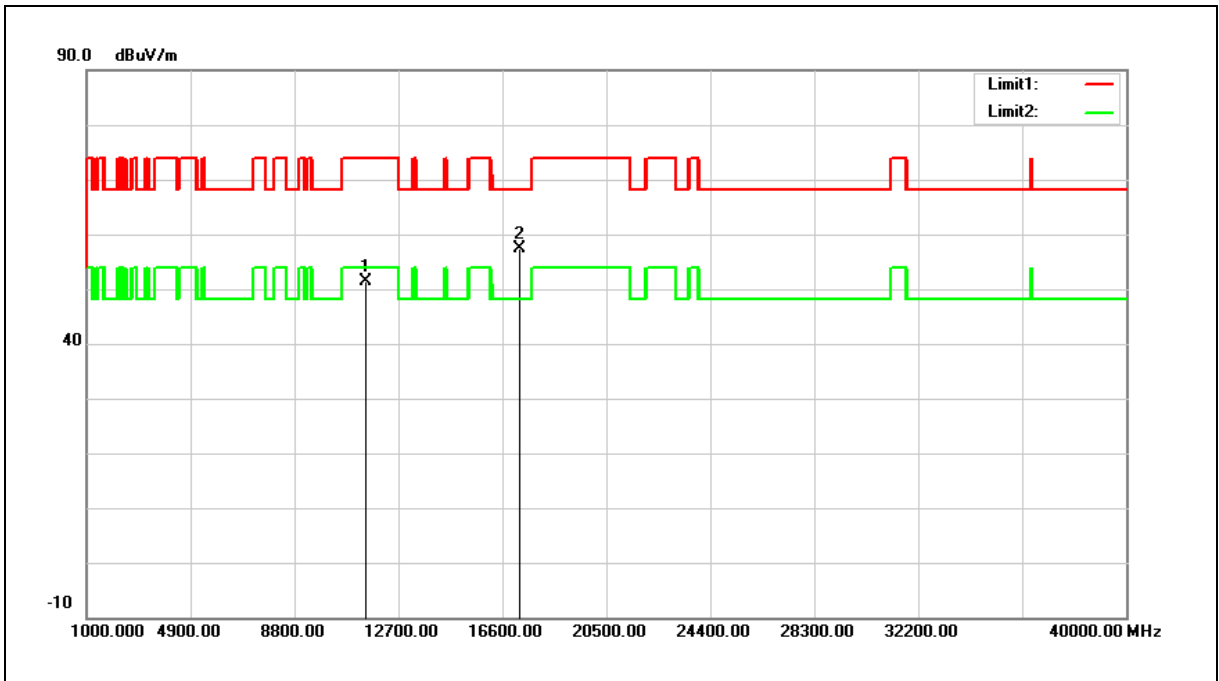

No.	Frequency (MHz)	Reading (dBuV)	Correct Factor (dB/m)	Result (dBuV/m)	Limit (dBuV/m)	Margin (dB)	Remark
1	11490.000	32.81	18.50	51.31	74.00	-22.69	peak
2	17235.000	33.08	24.29	57.37	68.20	-10.83	peak

Note:1.Result (dBuV/m) = Correct Factor (dB/m) + Reading(dBuV).

2.Correction factor (dB/m) = Antenna Factor (dB/m) + Cable loss (dB) – Pre-Amplifier gain (dB).

3.When the peak results are less than average limit, so not need to evaluate the average.

Standard:	FCC Part 15.407	Test Distance:	3 m
Test item:	Harmonic		
Frequency:	5785 MHz		
Mode:	Mode 8		
Ant.Polar.:	Horizontal		

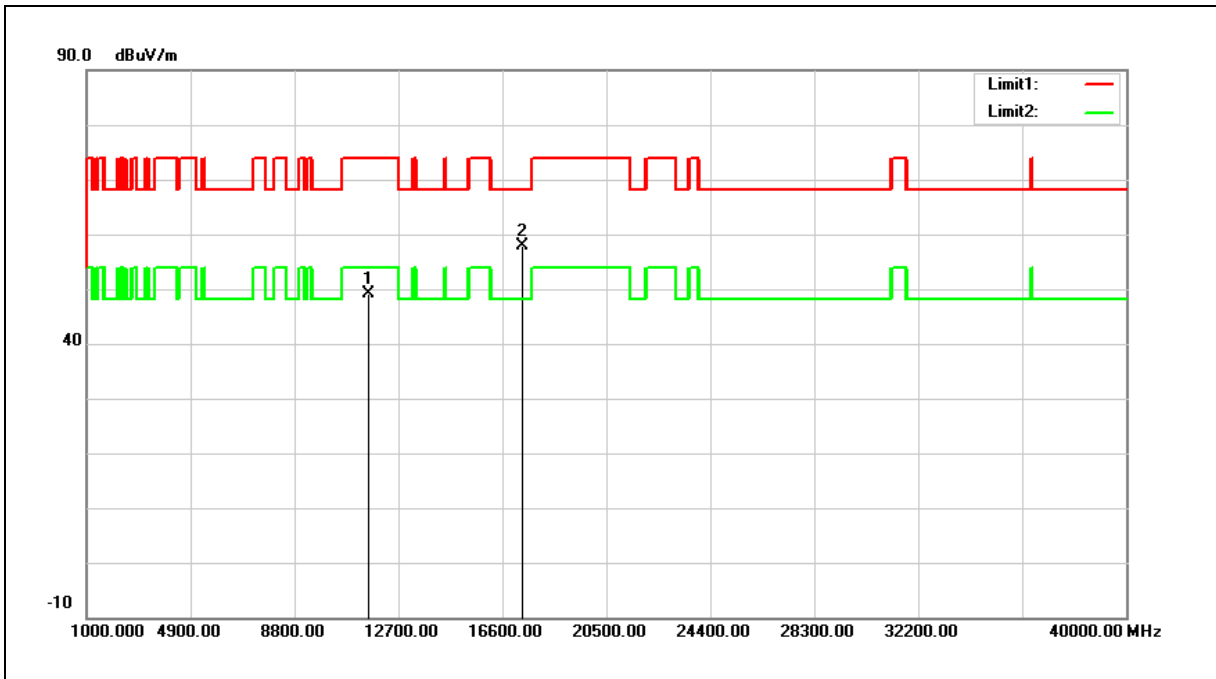

No.	Frequency (MHz)	Reading (dBuV)	Correct Factor (dB/m)	Result (dBuV/m)	Limit (dBuV/m)	Margin (dB)	Remark
1	11570.000	30.76	18.43	49.19	74.00	-24.81	peak
2	17355.000	32.92	24.95	57.87	68.20	-10.33	peak

Note:1.Result (dBuV/m) = Correct Factor (dB/m) + Reading(dBuV).

2.Correction factor (dB/m) = Antenna Factor (dB/m) + Cable loss (dB) – Pre-Amplifier gain (dB).

3.When the peak results are less than average limit, so not need to evaluate the average.

Standard:	FCC Part 15.407	Test Distance:	3 m
Test item:	Harmonic		
Frequency:	5785 MHz		
Mode:	Mode 8		
Ant.Polar.:	Vertical		

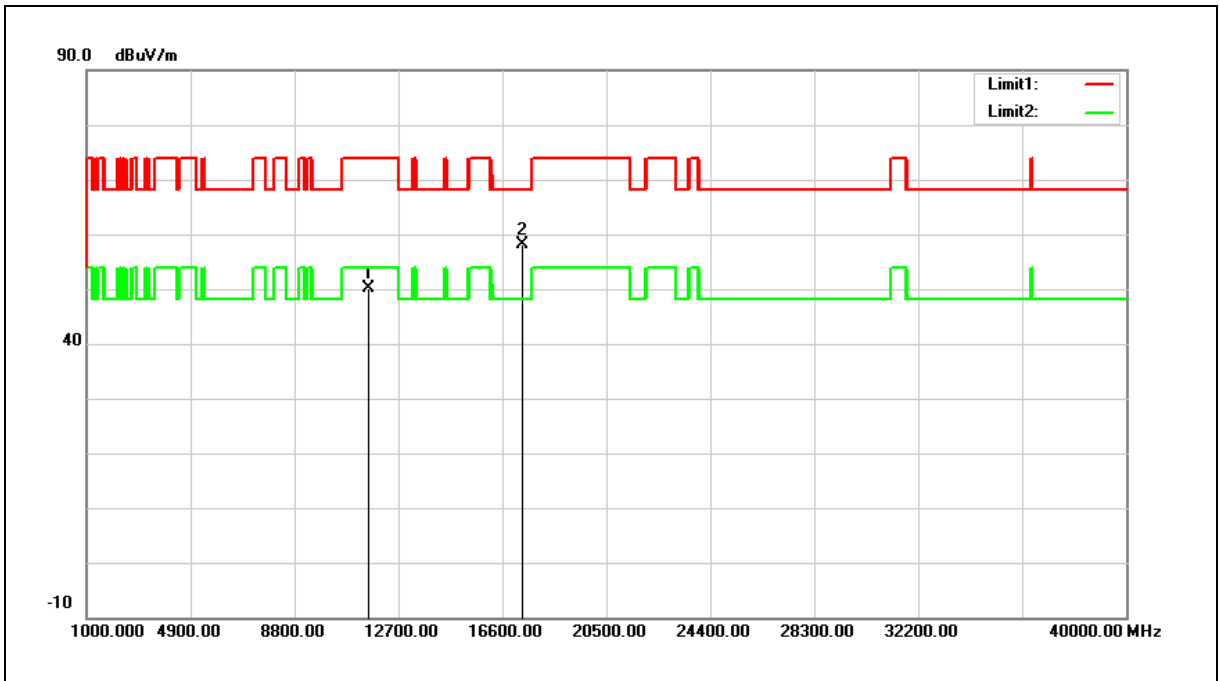

No.	Frequency (MHz)	Reading (dBuV)	Correct Factor (dB/m)	Result (dBuV/m)	Limit (dBuV/m)	Margin (dB)	Remark
1	11570.000	31.81	18.43	50.24	74.00	-23.76	peak
2	17355.000	33.28	24.95	58.23	68.20	-9.97	peak

Note:1.Result (dBuV/m) = Correct Factor (dB/m) + Reading(dBuV).

2.Correction factor (dB/m) = Antenna Factor (dB/m) + Cable loss (dB) – Pre-Amplifier gain (dB).

3.When the peak results are less than average limit, so not need to evaluate the average.

Standard:	FCC Part 15.407	Test Distance:	3 m
Test item:	Harmonic		
Frequency:	5825 MHz		
Mode:	Mode 8		
Ant.Polar.:	Horizontal		

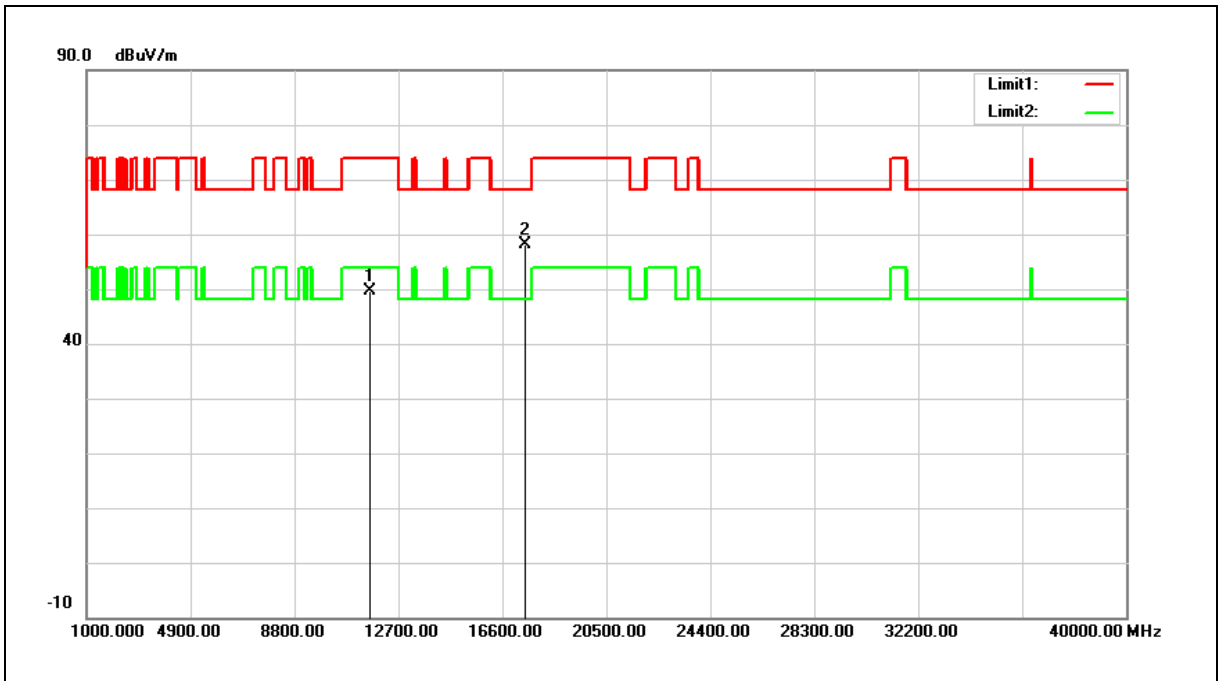

No.	Frequency (MHz)	Reading (dBuV)	Correct Factor (dB/m)	Result (dBuV/m)	Limit (dBuV/m)	Margin (dB)	Remark
1	11650.000	31.33	18.36	49.69	74.00	-24.31	peak
2	17475.000	32.57	25.60	58.17	68.20	-10.03	peak

Note:1.Result (dBuV/m) = Correct Factor (dB/m) + Reading(dBuV).

2.Correction factor (dB/m) = Antenna Factor (dB/m) + Cable loss (dB) – Pre-Amplifier gain (dB).

3.When the peak results are less than average limit, so not need to evaluate the average.

Standard:	FCC Part 15.407	Test Distance:	3 m
Test item:	Harmonic		
Frequency:	5825 MHz		
Mode:	Mode 8		
Ant.Polar.:	Vertical		

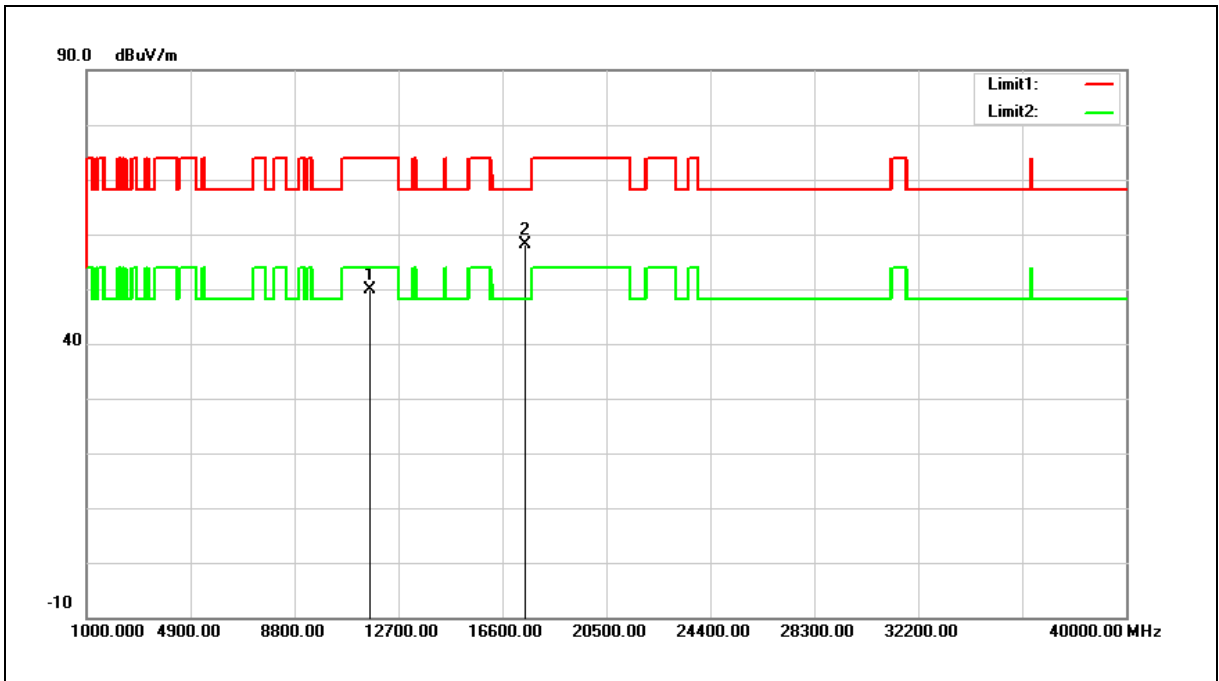

No.	Frequency (MHz)	Reading (dBuV)	Correct Factor (dB/m)	Result (dBuV/m)	Limit (dBuV/m)	Margin (dB)	Remark
1	11650.000	31.53	18.36	49.89	74.00	-24.11	peak
2	17475.000	32.55	25.60	58.15	68.20	-10.05	peak

Note:1.Result (dBuV/m) = Correct Factor (dB/m) + Reading(dBuV).

2.Correction factor (dB/m) = Antenna Factor (dB/m) + Cable loss (dB) – Pre-Amplifier gain (dB).

3.When the peak results are less than average limit, so not need to evaluate the average.

Standard:	FCC Part 15.407	Test Distance:	3 m
Test item:	Harmonic		
Frequency:	5190 MHz		
Mode:	Mode 9		
Ant.Polar.:	Horizontal		

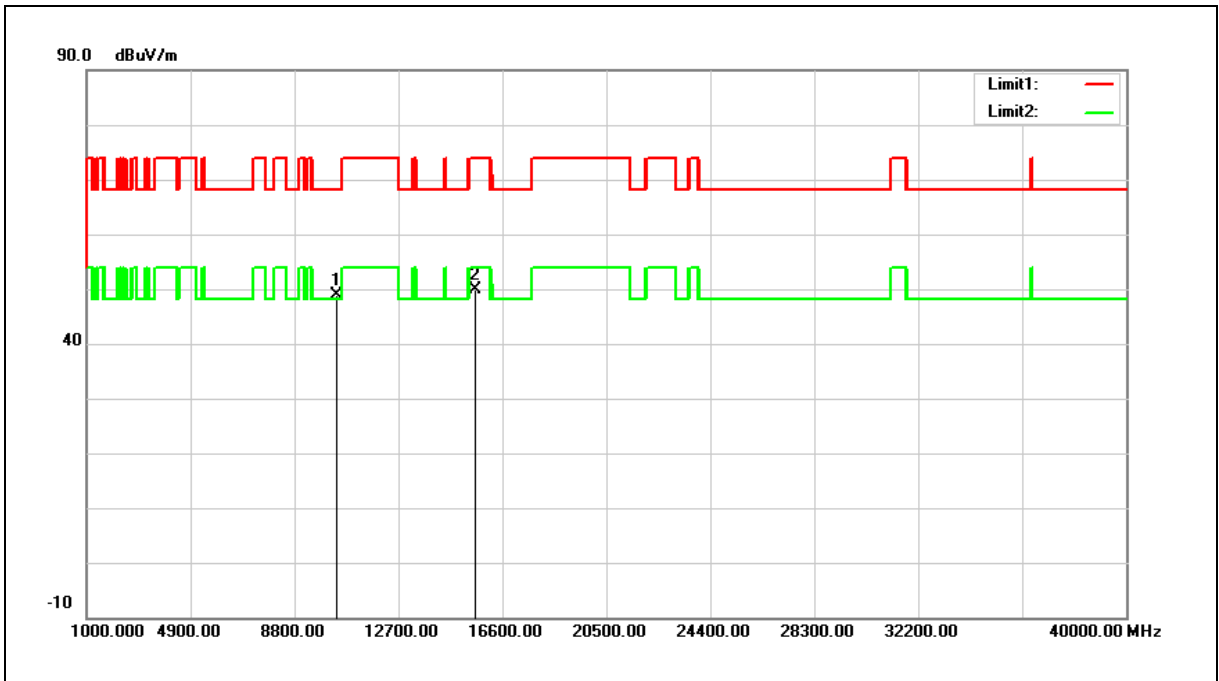

No.	Frequency (MHz)	Reading (dBuV)	Correct Factor (dB/m)	Result (dBuV/m)	Limit (dBuV/m)	Margin (dB)	Remark
1	10380.000	31.95	16.90	48.85	68.20	-19.35	peak
2	15570.000	31.47	18.43	49.90	74.00	-24.10	peak

Note:1.Result (dBuV/m) = Correct Factor (dB/m) + Reading(dBuV).

2.Correction factor (dB/m) = Antenna Factor (dB/m) + Cable loss (dB) – Pre-Amplifier gain (dB).

3.When the peak results are less than average limit, so not need to evaluate the average.

Standard:	FCC Part 15.407	Test Distance:	3 m
Test item:	Harmonic		
Frequency:	5190 MHz		
Mode:	Mode 9		
Ant.Polar.:	Vertical		

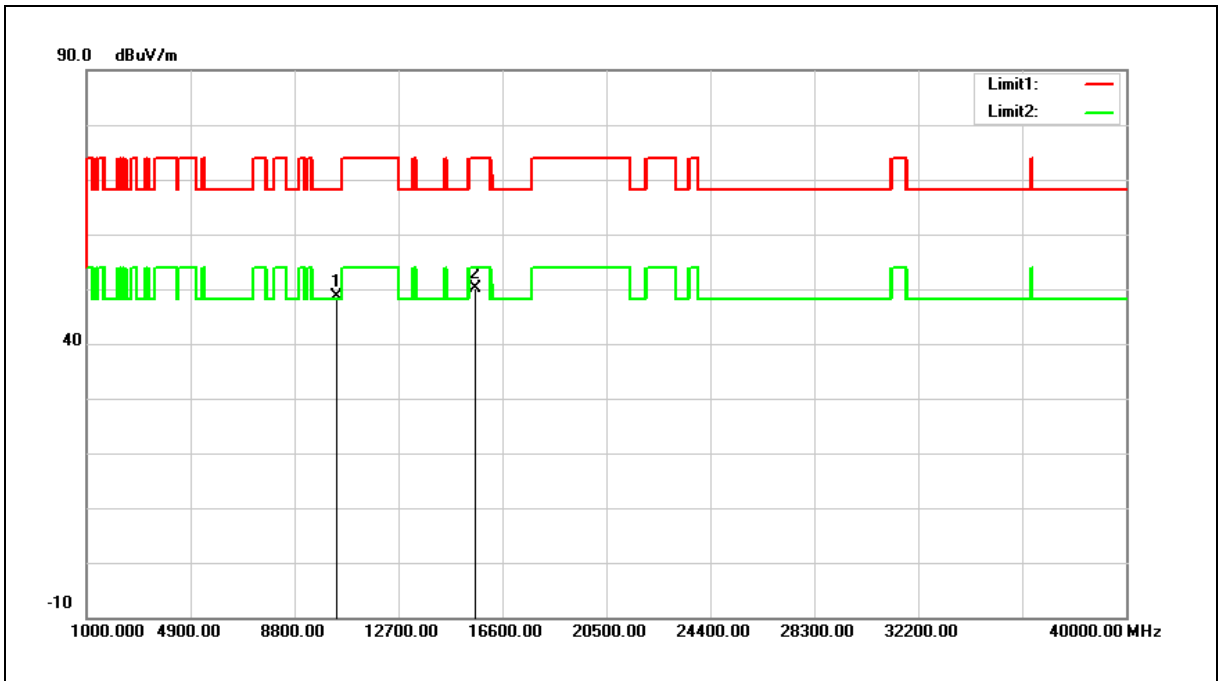

No.	Frequency (MHz)	Reading (dBuV)	Correct Factor (dB/m)	Result (dBuV/m)	Limit (dBuV/m)	Margin (dB)	Remark
1	10380.000	31.62	16.90	48.52	68.20	-19.68	peak
2	15570.000	31.72	18.43	50.15	74.00	-23.85	peak

Note:1.Result (dBuV/m) = Correct Factor (dB/m) + Reading(dBuV).

2.Correction factor (dB/m) = Antenna Factor (dB/m) + Cable loss (dB) – Pre-Amplifier gain (dB).

3.When the peak results are less than average limit, so not need to evaluate the average.

Standard:	FCC Part 15.407	Test Distance:	3 m
Test item:	Harmonic		
Frequency:	5230 MHz		
Mode:	Mode 9		
Ant.Polar.:	Horizontal		

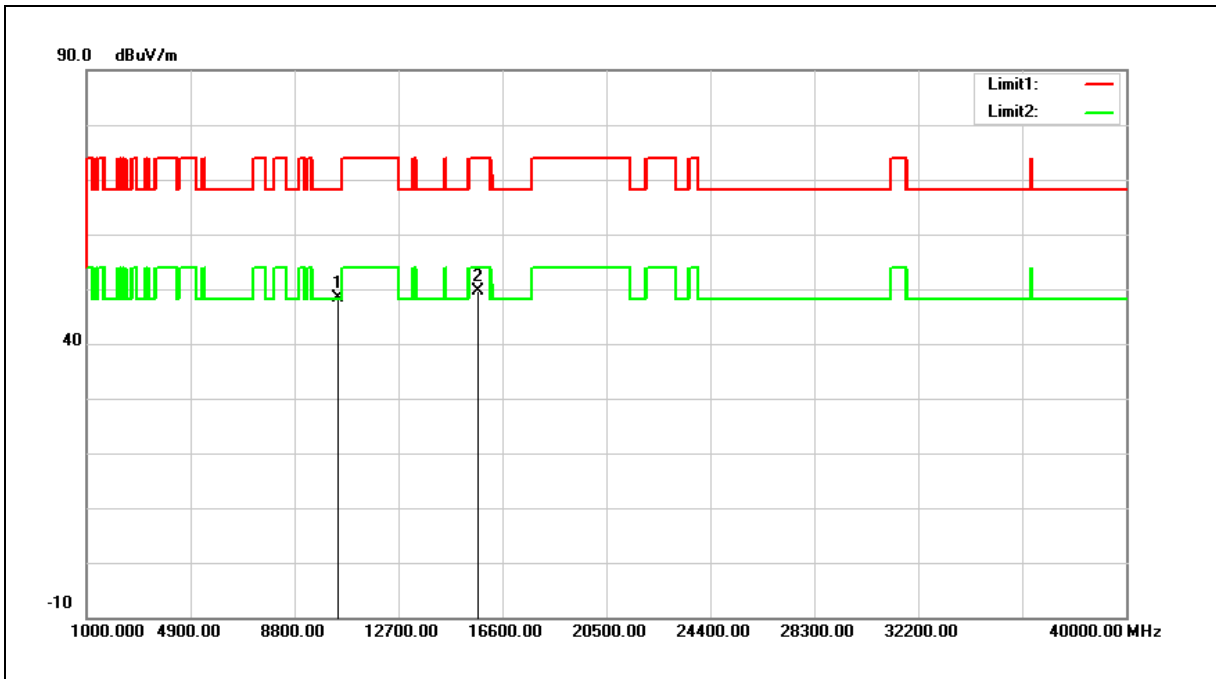

No.	Frequency (MHz)	Reading (dBuV)	Correct Factor (dB/m)	Result (dBuV/m)	Limit (dBuV/m)	Margin (dB)	Remark
1	10460.000	31.35	17.08	48.43	68.20	-19.77	peak
2	15690.000	31.66	18.08	49.74	74.00	-24.26	peak

- Note:1.Result (dBuV/m) = Correct Factor (dB/m) + Reading(dBuV).
- 2.Correction factor (dB/m) = Antenna Factor (dB/m) + Cable loss (dB) – Pre-Amplifier gain (dB).
- 3.When the peak results are less than average limit, so not need to evaluate the average.

Standard:	FCC Part 15.407	Test Distance:	3 m
Test item:	Harmonic		
Frequency:	5230 MHz		
Mode:	Mode 9		
Ant.Polar.:	Vertical		

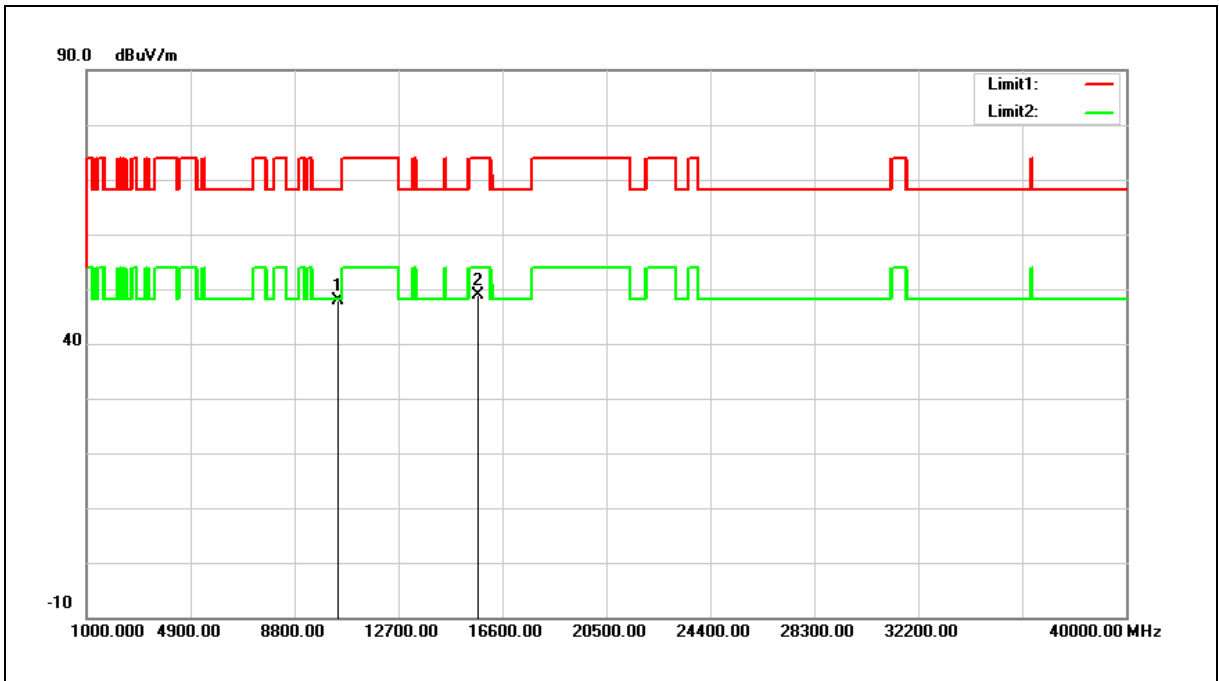

No.	Frequency (MHz)	Reading (dBuV)	Correct Factor (dB/m)	Result (dBuV/m)	Limit (dBuV/m)	Margin (dB)	Remark
1	10460.000	30.83	17.08	47.91	68.20	-20.29	peak
2	15690.000	30.75	18.08	48.83	74.00	-25.17	peak

Note:1.Result (dBuV/m) = Correct Factor (dB/m) + Reading(dBuV).

2.Correction factor (dB/m) = Antenna Factor (dB/m) + Cable loss (dB) – Pre-Amplifier gain (dB).

3.When the peak results are less than average limit, so not need to evaluate the average.

Standard:	FCC Part 15.407	Test Distance:	3 m
Test item:	Harmonic		
Frequency:	5270 MHz		
Mode:	Mode 9		
Ant.Polar.:	Horizontal		

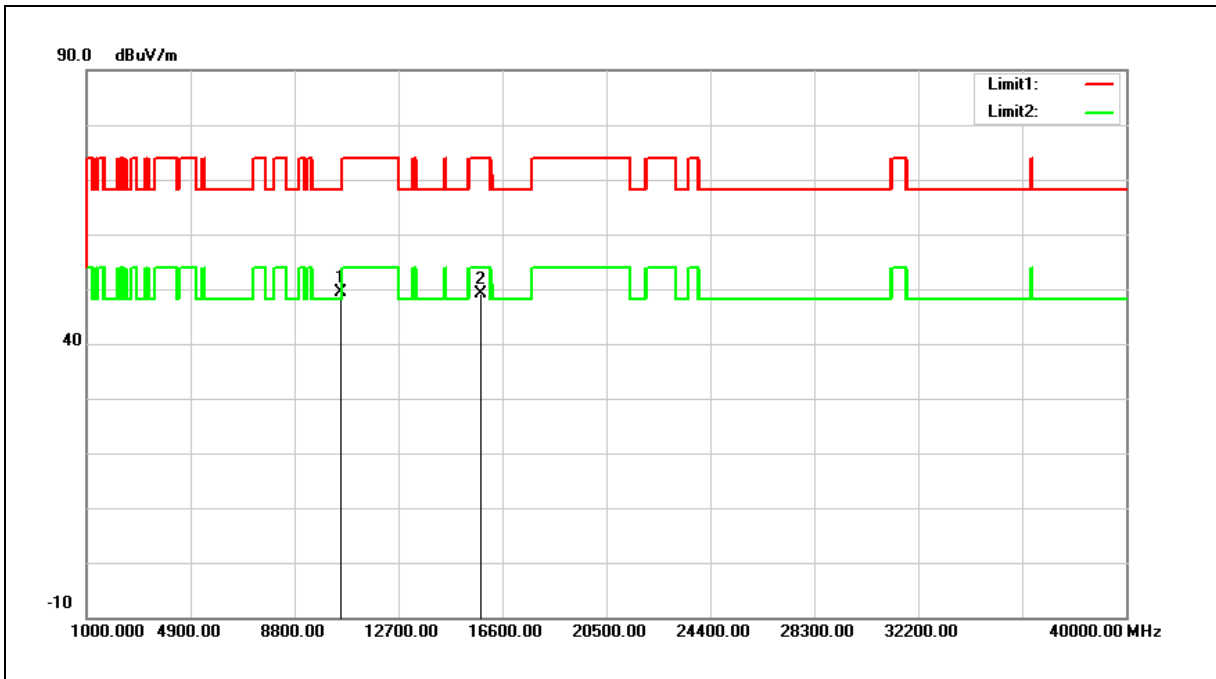

No.	Frequency (MHz)	Reading (dBuV)	Correct Factor (dB/m)	Result (dBuV/m)	Limit (dBuV/m)	Margin (dB)	Remark
1	10540.000	32.18	17.26	49.44	68.20	-18.76	peak
2	15810.000	31.31	17.74	49.05	74.00	-24.95	peak

Note:1.Result (dBuV/m) = Correct Factor (dB/m) + Reading(dBuV).

2.Correction factor (dB/m) = Antenna Factor (dB/m) + Cable loss (dB) – Pre-Amplifier gain (dB).

3.When the peak results are less than average limit, so not need to evaluate the average.

Standard:	FCC Part 15.407	Test Distance:	3 m
Test item:	Harmonic		
Frequency:	5270 MHz		
Mode:	Mode 9		
Ant.Polar.:	Vertical		

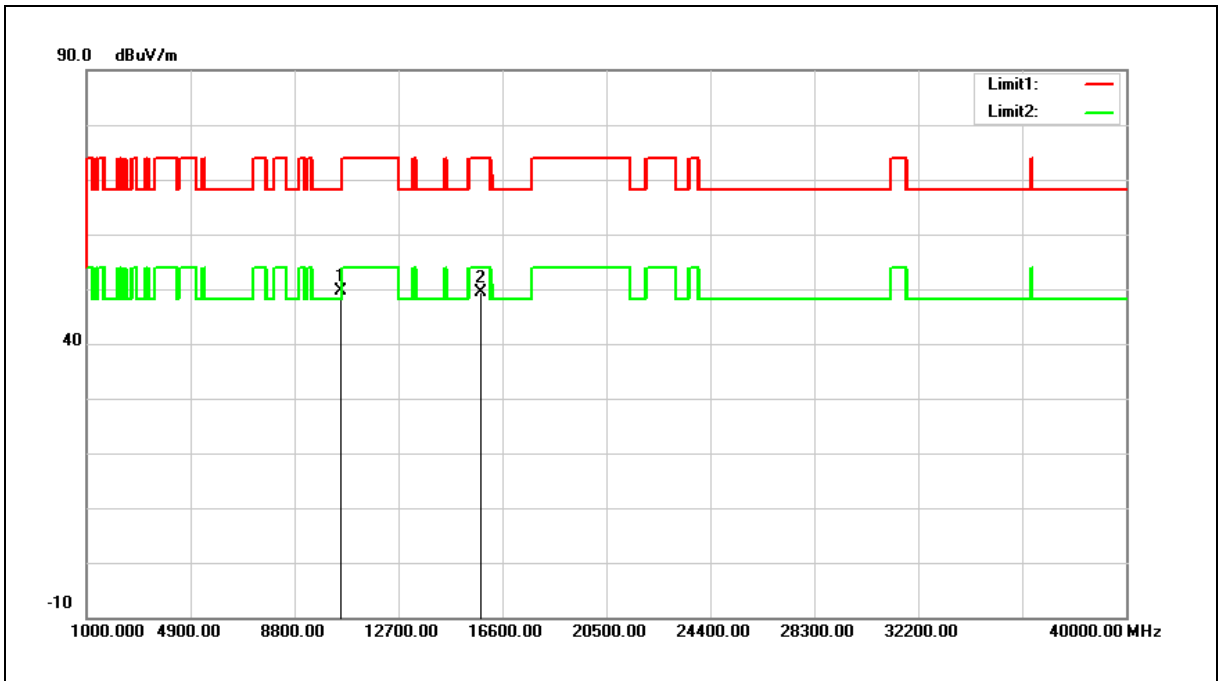

No.	Frequency (MHz)	Reading (dBuV)	Correct Factor (dB/m)	Result (dBuV/m)	Limit (dBuV/m)	Margin (dB)	Remark
1	10540.000	32.32	17.26	49.58	68.20	-18.62	peak
2	15810.000	31.54	17.74	49.28	74.00	-24.72	peak

Note:1.Result (dBuV/m) = Correct Factor (dB/m) + Reading(dBuV).

2.Correction factor (dB/m) = Antenna Factor (dB/m) + Cable loss (dB) – Pre-Amplifier gain (dB).

3.When the peak results are less than average limit, so not need to evaluate the average.

Standard:	FCC Part 15.407	Test Distance:	3 m
Test item:	Harmonic		
Frequency:	5310 MHz		
Mode:	Mode 9		
Ant.Polar.:	Horizontal		

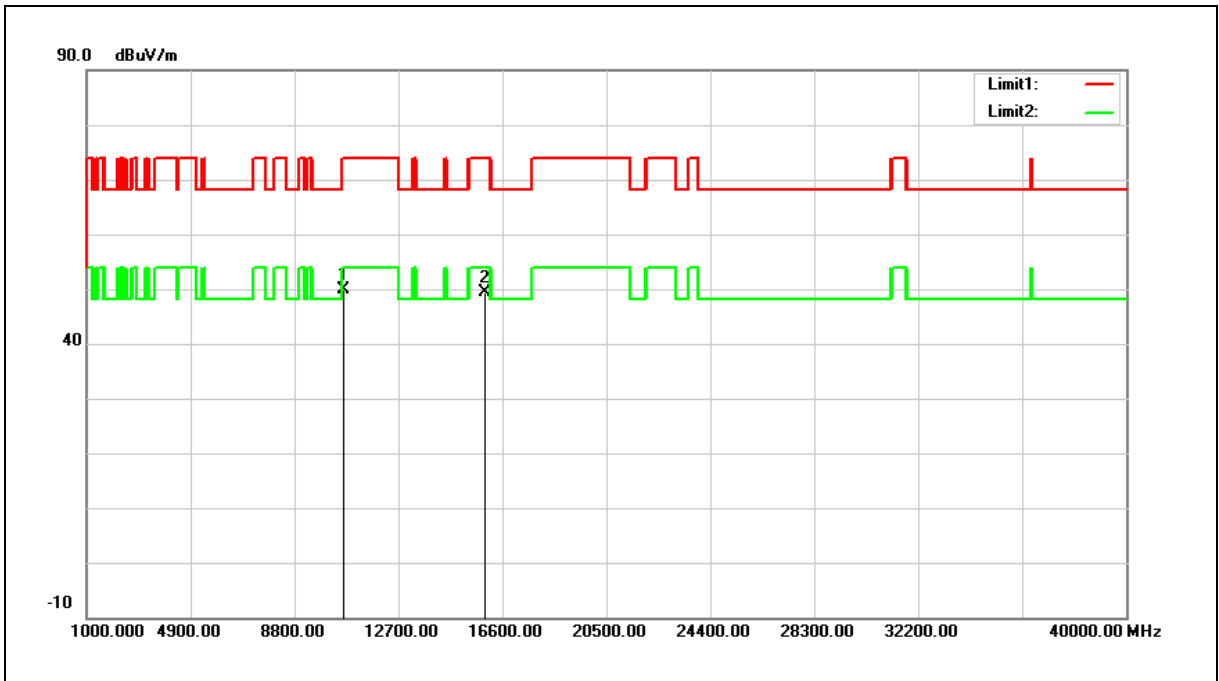

No.	Frequency (MHz)	Reading (dBuV)	Correct Factor (dB/m)	Result (dBuV/m)	Limit (dBuV/m)	Margin (dB)	Remark
1	10620.000	32.33	17.44	49.77	74.00	-24.23	peak
2	15930.000	32.00	17.39	49.39	74.00	-24.61	peak

Note:1.Result (dBuV/m) = Correct Factor (dB/m) + Reading(dBuV).

2.Correction factor (dB/m) = Antenna Factor (dB/m) + Cable loss (dB) – Pre-Amplifier gain (dB).

3.When the peak results are less than average limit, so not need to evaluate the average.

Standard:	FCC Part 15.407	Test Distance:	3 m
Test item:	Harmonic		
Frequency:	5310 MHz		
Mode:	Mode 9		
Ant.Polar.:	Vertical		

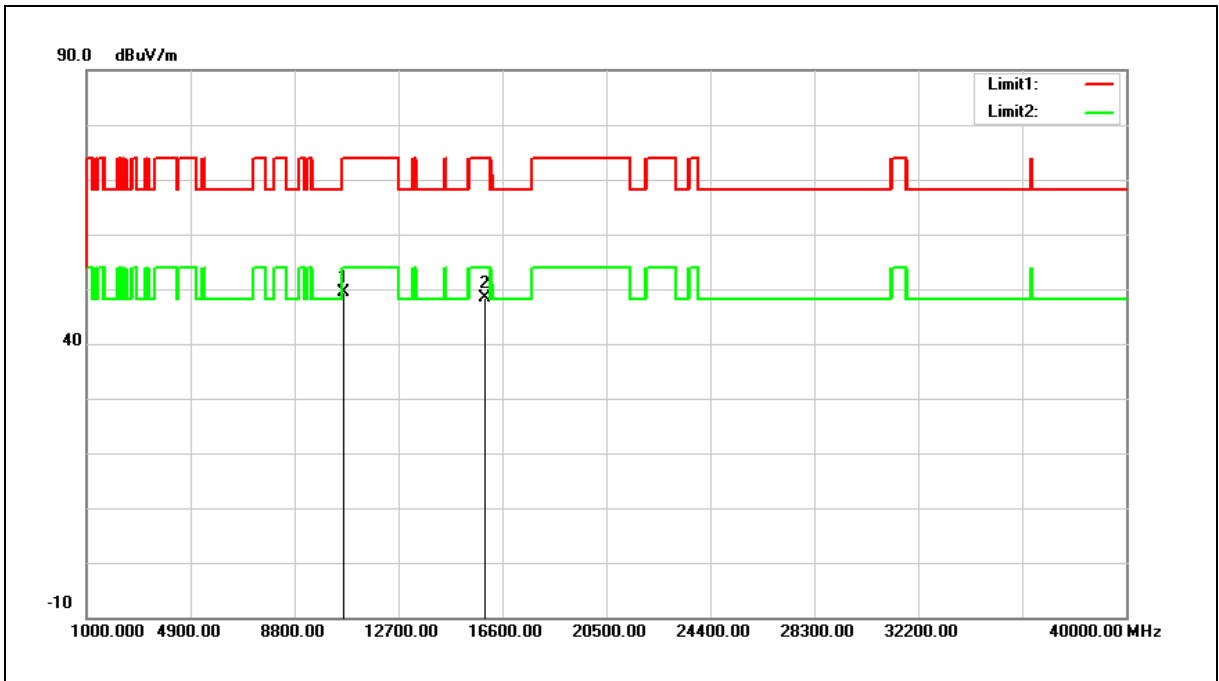

No.	Frequency (MHz)	Reading (dBuV)	Correct Factor (dB/m)	Result (dBuV/m)	Limit (dBuV/m)	Margin (dB)	Remark
1	10620.000	31.99	17.44	49.43	74.00	-24.57	peak
2	15930.000	31.03	17.39	48.42	74.00	-25.58	peak

Note:1.Result (dBuV/m) = Correct Factor (dB/m) + Reading(dBuV).

2.Correction factor (dB/m) = Antenna Factor (dB/m) + Cable loss (dB) – Pre-Amplifier gain (dB).

3.When the peak results are less than average limit, so not need to evaluate the average.

Standard:	FCC Part 15.407	Test Distance:	3 m
Test item:	Harmonic		
Frequency:	5510 MHz		
Mode:	Mode 9		
Ant.Polar.:	Horizontal		

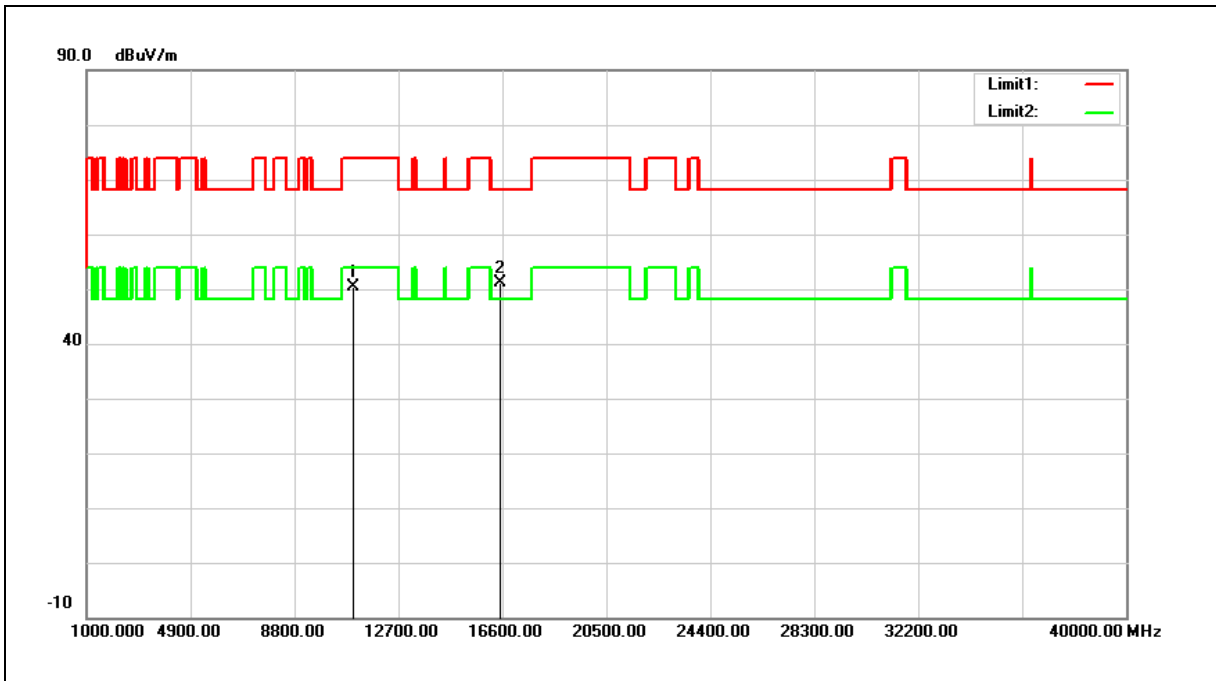

No.	Frequency (MHz)	Reading (dBuV)	Correct Factor (dB/m)	Result (dBuV/m)	Limit (dBuV/m)	Margin (dB)	Remark
1	11020.000	32.13	18.30	50.43	74.00	-23.57	peak
2	16530.000	31.12	19.98	51.10	68.20	-17.10	peak

Note:1.Result (dBuV/m) = Correct Factor (dB/m) + Reading(dBuV).

2.Correction factor (dB/m) = Antenna Factor (dB/m) + Cable loss (dB) – Pre-Amplifier gain (dB).

3.When the peak results are less than average limit, so not need to evaluate the average.

Standard:	FCC Part 15.407	Test Distance:	3 m
Test item:	Harmonic		
Frequency:	5510 MHz		
Mode:	Mode 9		
Ant.Polar.:	Vertical		

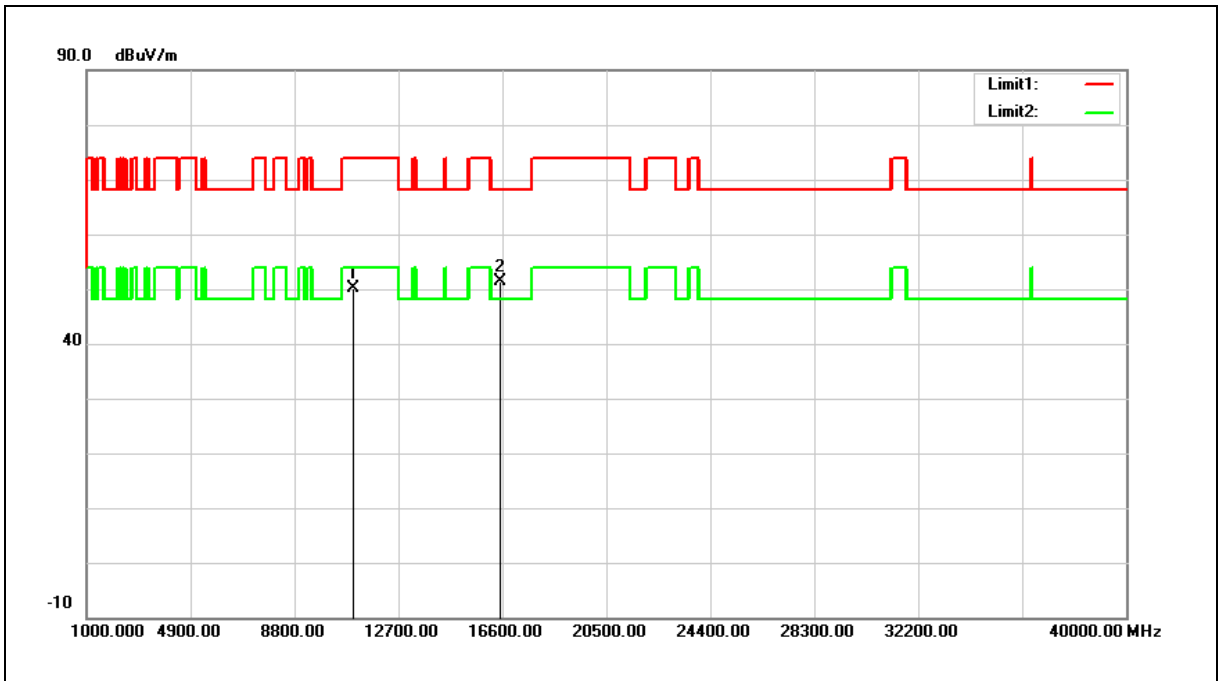

No.	Frequency (MHz)	Reading (dBuV)	Correct Factor (dB/m)	Result (dBuV/m)	Limit (dBuV/m)	Margin (dB)	Remark
1	11020.000	31.87	18.30	50.17	74.00	-23.83	peak
2	16530.000	31.43	19.98	51.41	68.20	-16.79	peak

Note:1.Result (dBuV/m) = Correct Factor (dB/m) + Reading(dBuV).

2.Correction factor (dB/m) = Antenna Factor (dB/m) + Cable loss (dB) – Pre-Amplifier gain (dB).

3.When the peak results are less than average limit, so not need to evaluate the average.

Standard:	FCC Part 15.407	Test Distance:	3 m
Test item:	Harmonic		
Frequency:	5550 MHz		
Mode:	Mode 9		
Ant.Polar.:	Horizontal		

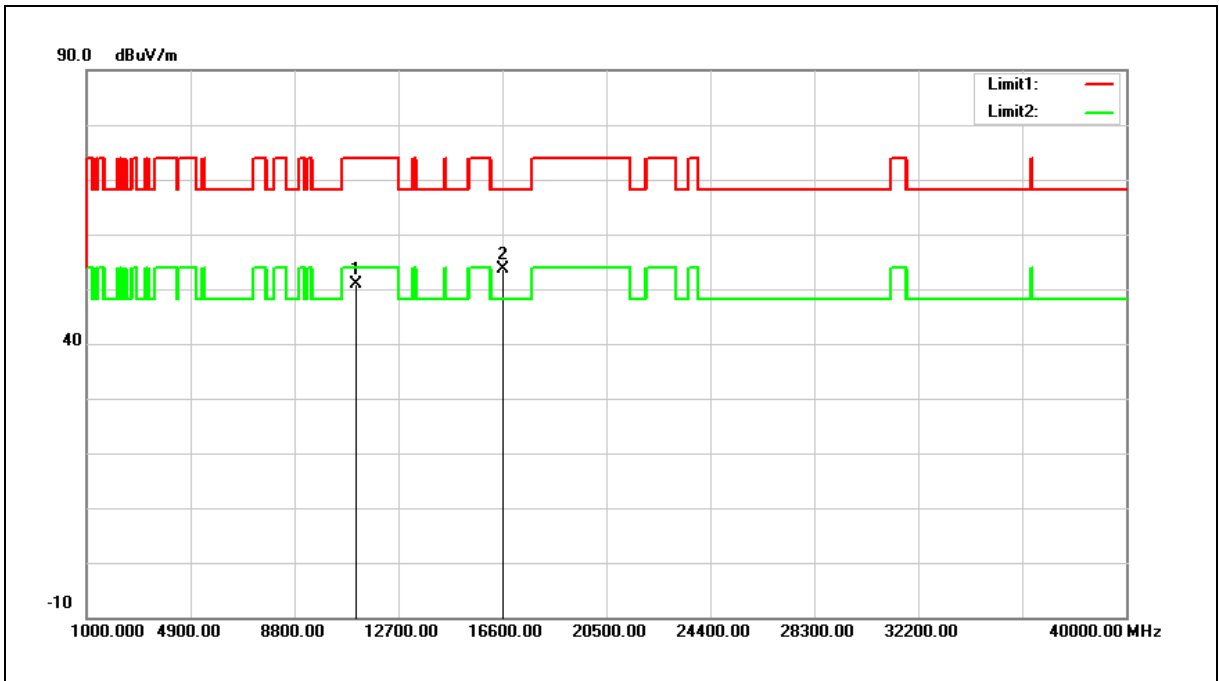

No.	Frequency (MHz)	Reading (dBuV)	Correct Factor (dB/m)	Result (dBuV/m)	Limit (dBuV/m)	Margin (dB)	Remark
1	11100.000	32.59	18.33	50.92	74.00	-23.08	peak
2	16650.000	32.75	20.76	53.51	68.20	-14.69	peak

Note:1.Result (dBuV/m) = Correct Factor (dB/m) + Reading(dBuV).

2.Correction factor (dB/m) = Antenna Factor (dB/m) + Cable loss (dB) – Pre-Amplifier gain (dB).

3.When the peak results are less than average limit, so not need to evaluate the average.

Standard:	FCC Part 15.407	Test Distance:	3 m
Test item:	Harmonic		
Frequency:	5550 MHz		
Mode:	Mode 9		
Ant.Polar.:	Vertical		

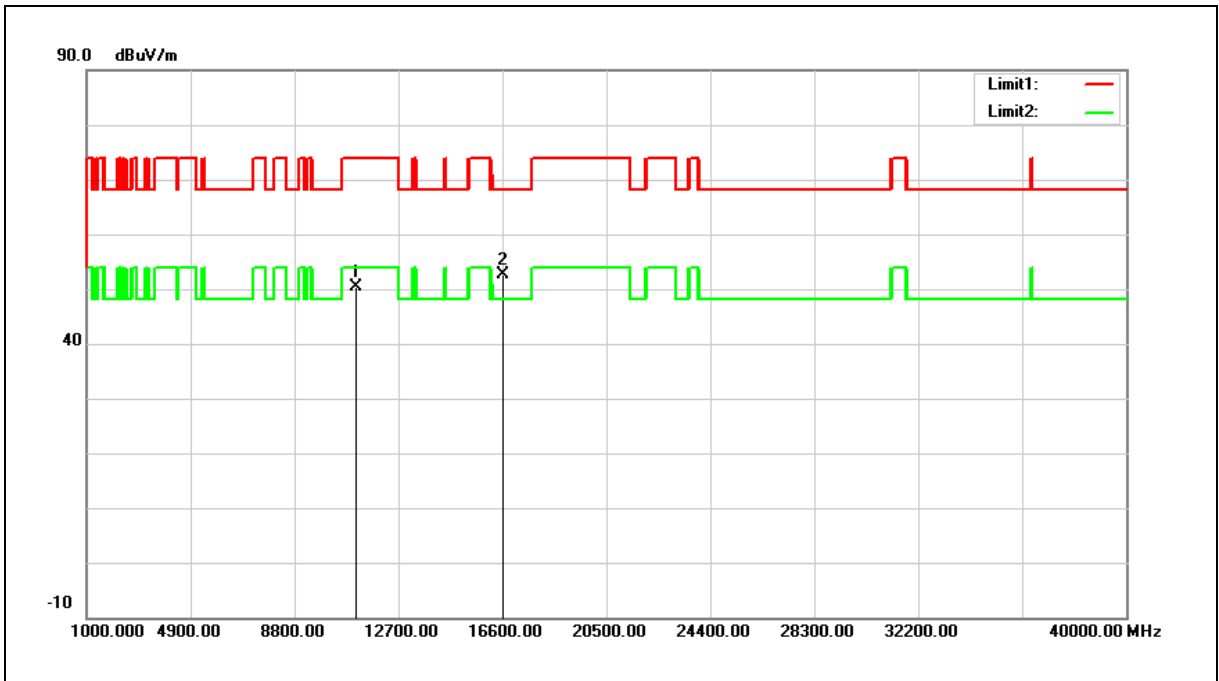

No.	Frequency (MHz)	Reading (dBuV)	Correct Factor (dB/m)	Result (dBuV/m)	Limit (dBuV/m)	Margin (dB)	Remark
1	11100.000	32.13	18.33	50.46	74.00	-23.54	peak
2	16650.000	31.75	20.76	52.51	68.20	-15.69	peak

Note:1.Result (dBuV/m) = Correct Factor (dB/m) + Reading(dBuV).

2.Correction factor (dB/m) = Antenna Factor (dB/m) + Cable loss (dB) – Pre-Amplifier gain (dB).

3.When the peak results are less than average limit, so not need to evaluate the average.

Standard:	FCC Part 15.407	Test Distance:	3 m
Test item:	Harmonic		
Frequency:	5670 MHz		
Mode:	Mode 9		
Ant.Polar.:	Horizontal		

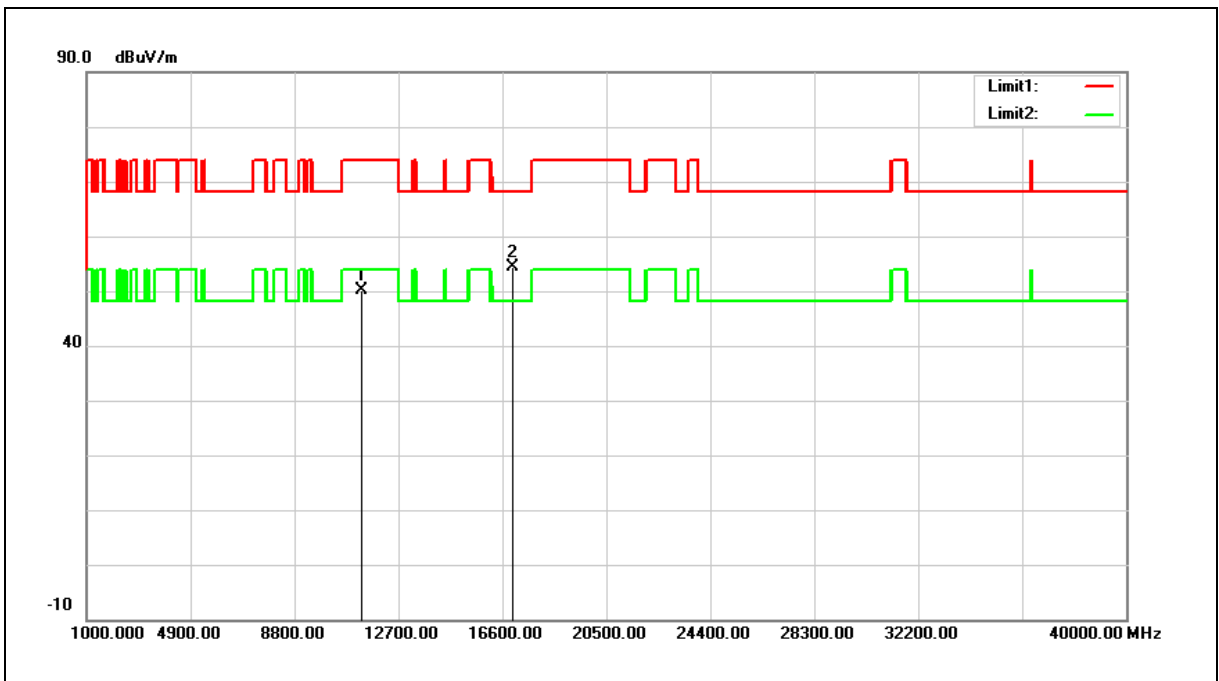

No.	Frequency (MHz)	Reading (dBuV)	Correct Factor (dB/m)	Result (dBuV/m)	Limit (dBuV/m)	Margin (dB)	Remark
1	11340.000	31.81	18.43	50.24	74.00	-23.76	peak
2	17010.000	31.35	23.06	54.41	68.20	-13.79	peak

Note:1.Result (dBuV/m) = Correct Factor (dB/m) + Reading(dBuV).

2.Correction factor (dB/m) = Antenna Factor (dB/m) + Cable loss (dB) – Pre-Amplifier gain (dB).

3.When the peak results are less than average limit, so not need to evaluate the average.

Standard:	FCC Part 15.407	Test Distance:	3 m
Test item:	Harmonic		
Frequency:	5670 MHz		
Mode:	Mode 9		
Ant.Polar.:	Vertical		

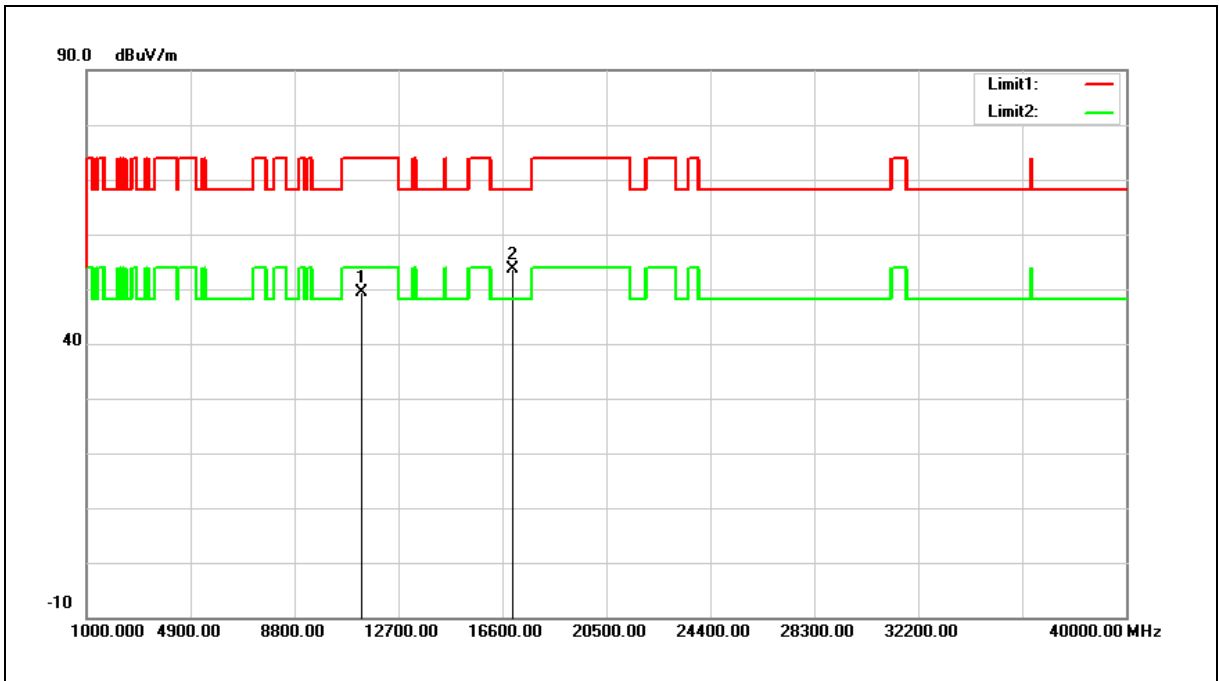

No.	Frequency (MHz)	Reading (dBuV)	Correct Factor (dB/m)	Result (dBuV/m)	Limit (dBuV/m)	Margin (dB)	Remark
1	11340.000	30.90	18.43	49.33	74.00	-24.67	peak
2	17010.000	30.61	23.06	53.67	68.20	-14.53	peak

Note:1.Result (dBuV/m) = Correct Factor (dB/m) + Reading(dBuV).

2.Correction factor (dB/m) = Antenna Factor (dB/m) + Cable loss (dB) – Pre-Amplifier gain (dB).

3.When the peak results are less than average limit, so not need to evaluate the average.

Standard:	FCC Part 15.407	Test Distance:	3 m
Test item:	Harmonic		
Frequency:	5710 MHz		
Mode:	Mode 9		
Ant.Polar.:	Horizontal		

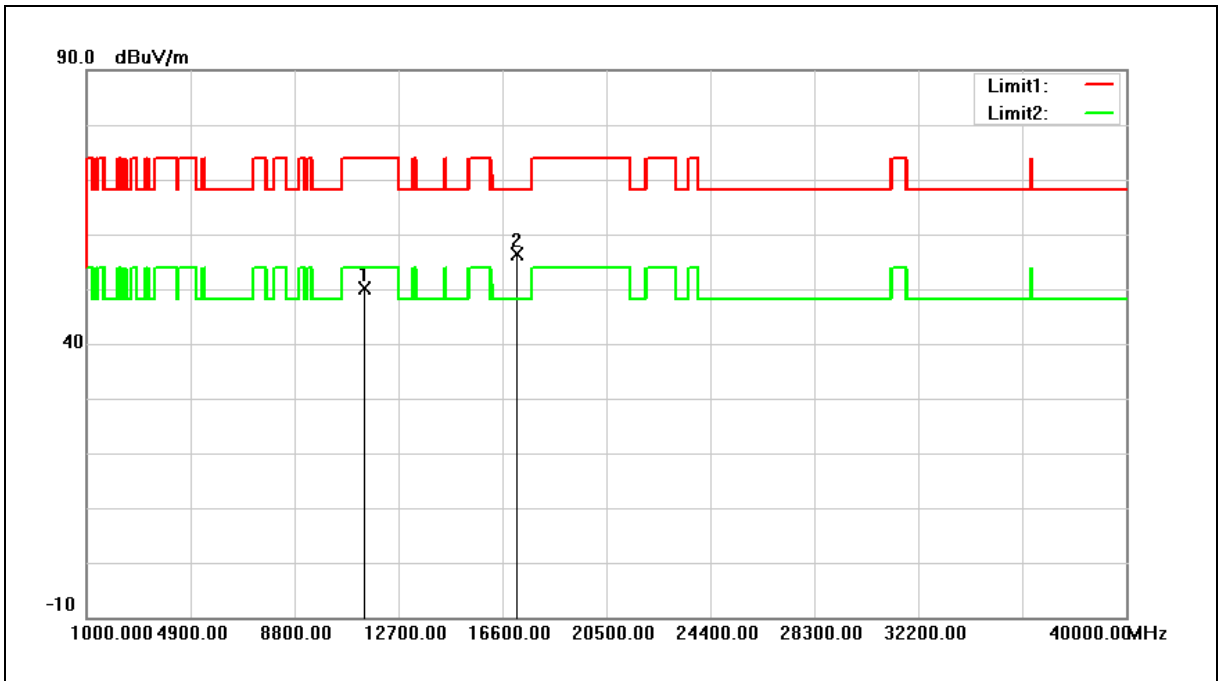

No.	Frequency (MHz)	Reading (dBuV)	Correct Factor (dB/m)	Result (dBuV/m)	Limit (dBuV/m)	Margin (dB)	Remark
1	11420.000	31.54	18.47	50.01	74.00	-23.99	peak
2	17130.000	32.72	23.71	56.43	68.20	-11.77	peak

- Note:1.Result (dBuV/m) = Correct Factor (dB/m) + Reading(dBuV).
 2.Correction factor (dB/m) = Antenna Factor (dB/m) + Cable loss (dB) – Pre-Amplifier gain (dB).
 3.When the peak results are less than average limit, so not need to evaluate the average.

Standard:	FCC Part 15.407	Test Distance:	3 m
Test item:	Harmonic		
Frequency:	5710 MHz		
Mode:	Mode 9		
Ant.Polar.:	Vertical		

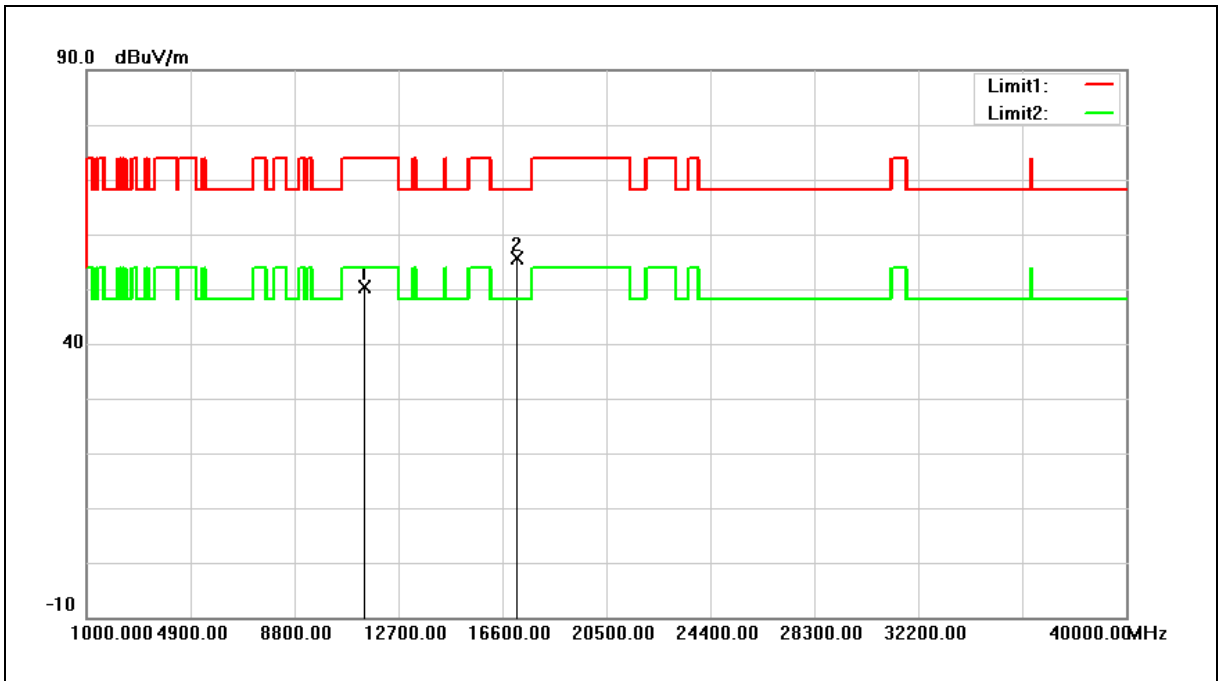

No.	Frequency (MHz)	Reading (dBuV)	Correct Factor (dB/m)	Result (dBuV/m)	Limit (dBuV/m)	Margin (dB)	Remark
1	11420.000	31.79	18.47	50.26	74.00	-23.74	peak
2	17130.000	31.99	23.71	55.70	68.20	-12.50	peak

Note:1.Result (dBuV/m) = Correct Factor (dB/m) + Reading(dBuV).

2.Correction factor (dB/m) = Antenna Factor (dB/m) + Cable loss (dB) – Pre-Amplifier gain (dB).

3.When the peak results are less than average limit, so not need to evaluate the average.

Standard:	FCC Part 15.407	Test Distance:	3 m
Test item:	Harmonic		
Frequency:	5755 MHz		
Mode:	Mode 9		
Ant.Polar.:	Horizontal		

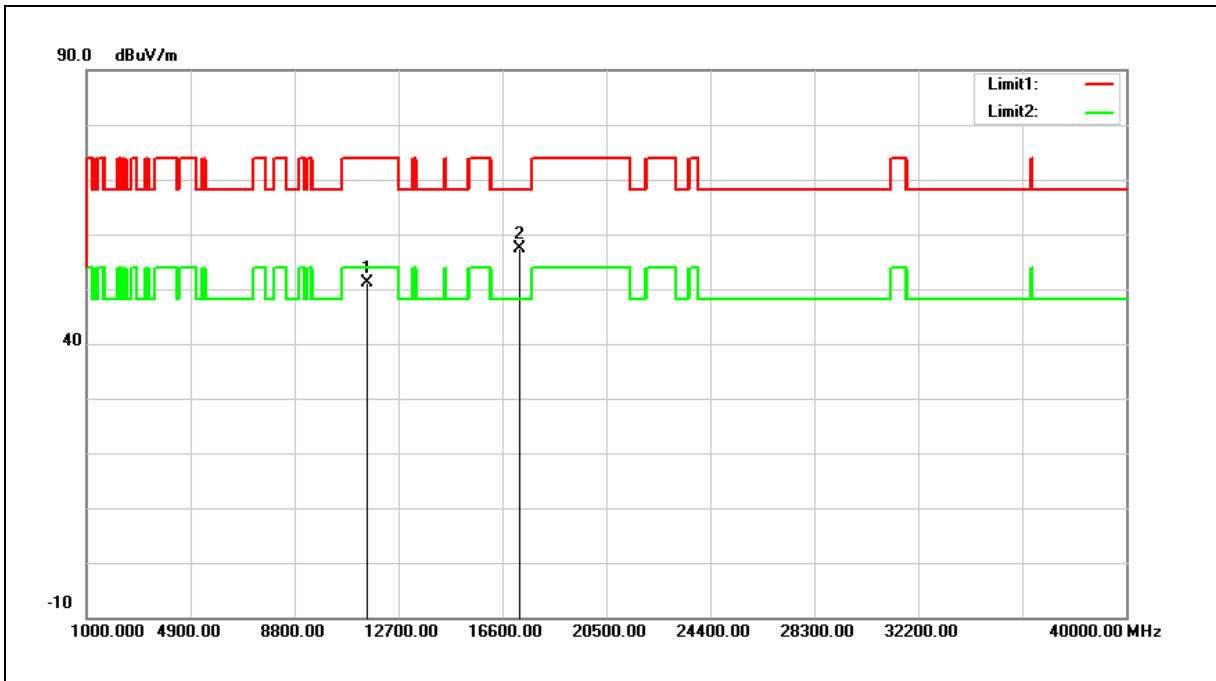

No.	Frequency (MHz)	Reading (dBuV)	Correct Factor (dB/m)	Result (dBuV/m)	Limit (dBuV/m)	Margin (dB)	Remark
1	11510.000	32.62	18.48	51.10	74.00	-22.90	peak
2	17265.000	33.00	24.45	57.45	68.20	-10.75	peak

Note:1.Result (dBuV/m) = Correct Factor (dB/m) + Reading(dBuV).

2.Correction factor (dB/m) = Antenna Factor (dB/m) + Cable loss (dB) – Pre-Amplifier gain (dB).

3.When the peak results are less than average limit, so not need to evaluate the average.

Standard:	FCC Part 15.407	Test Distance:	3 m
Test item:	Harmonic		
Frequency:	5755 MHz		
Mode:	Mode 9		
Ant.Polar.:	Vertical		

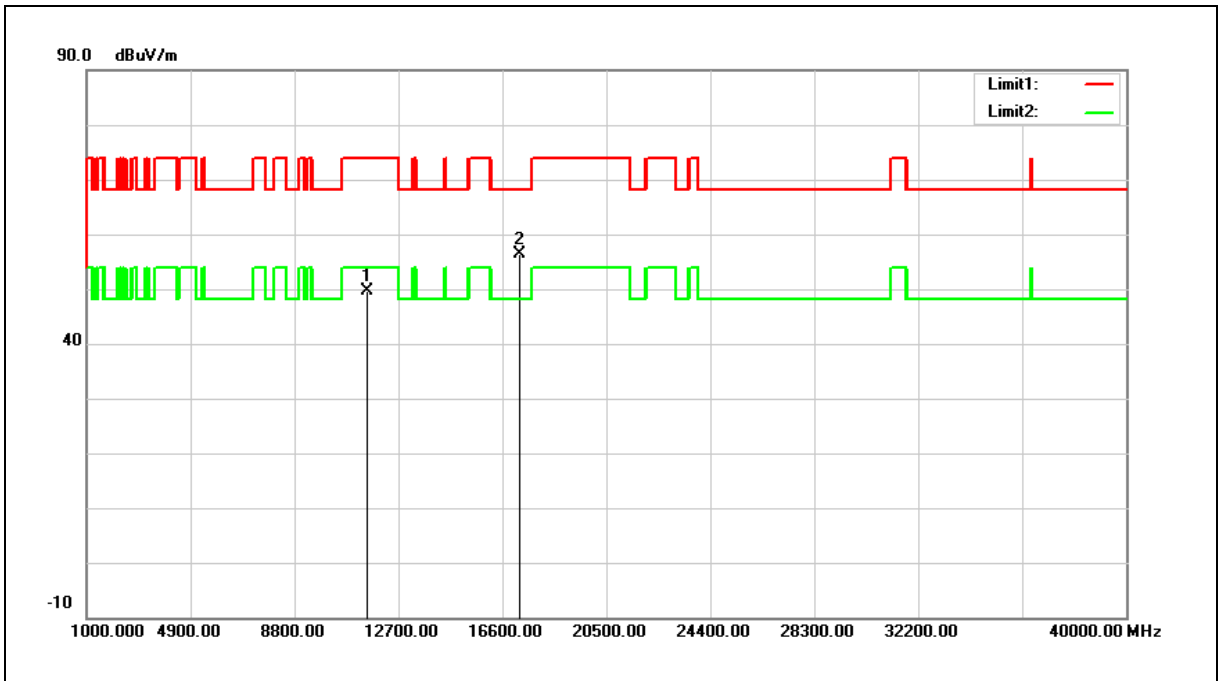

No.	Frequency (MHz)	Reading (dBuV)	Correct Factor (dB/m)	Result (dBuV/m)	Limit (dBuV/m)	Margin (dB)	Remark
1	11510.000	31.26	18.48	49.74	74.00	-24.26	peak
2	17265.000	31.86	24.45	56.31	68.20	-11.89	peak

Note:1.Result (dBuV/m) = Correct Factor (dB/m) + Reading(dBuV).

2.Correction factor (dB/m) = Antenna Factor (dB/m) + Cable loss (dB) – Pre-Amplifier gain (dB).

3.When the peak results are less than average limit, so not need to evaluate the average.

Standard:	FCC Part 15.407	Test Distance:	3 m
Test item:	Harmonic		
Frequency:	5795 MHz		
Mode:	Mode 9		
Ant.Polar.:	Horizontal		

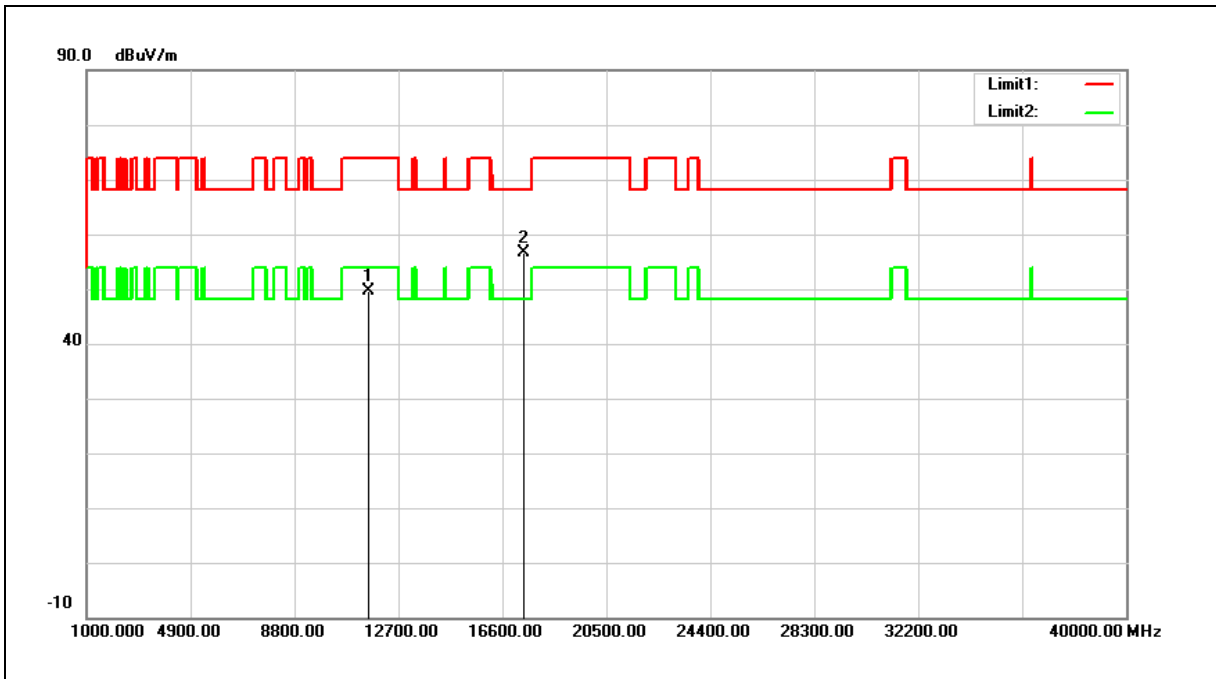

No.	Frequency (MHz)	Reading (dBuV)	Correct Factor (dB/m)	Result (dBuV/m)	Limit (dBuV/m)	Margin (dB)	Remark
1	11590.000	31.25	18.41	49.66	74.00	-24.34	peak
2	17385.000	31.65	25.10	56.75	68.20	-11.45	peak

- Note:1.Result (dBuV/m) = Correct Factor (dB/m) + Reading(dBuV).
 2.Correction factor (dB/m) = Antenna Factor (dB/m) + Cable loss (dB) – Pre-Amplifier gain (dB).
 3.When the peak results are less than average limit, so not need to evaluate the average.

Standard:	FCC Part 15.407	Test Distance:	3 m
Test item:	Harmonic		
Frequency:	5795 MHz		
Mode:	Mode 9		
Ant.Polar.:	Vertical		

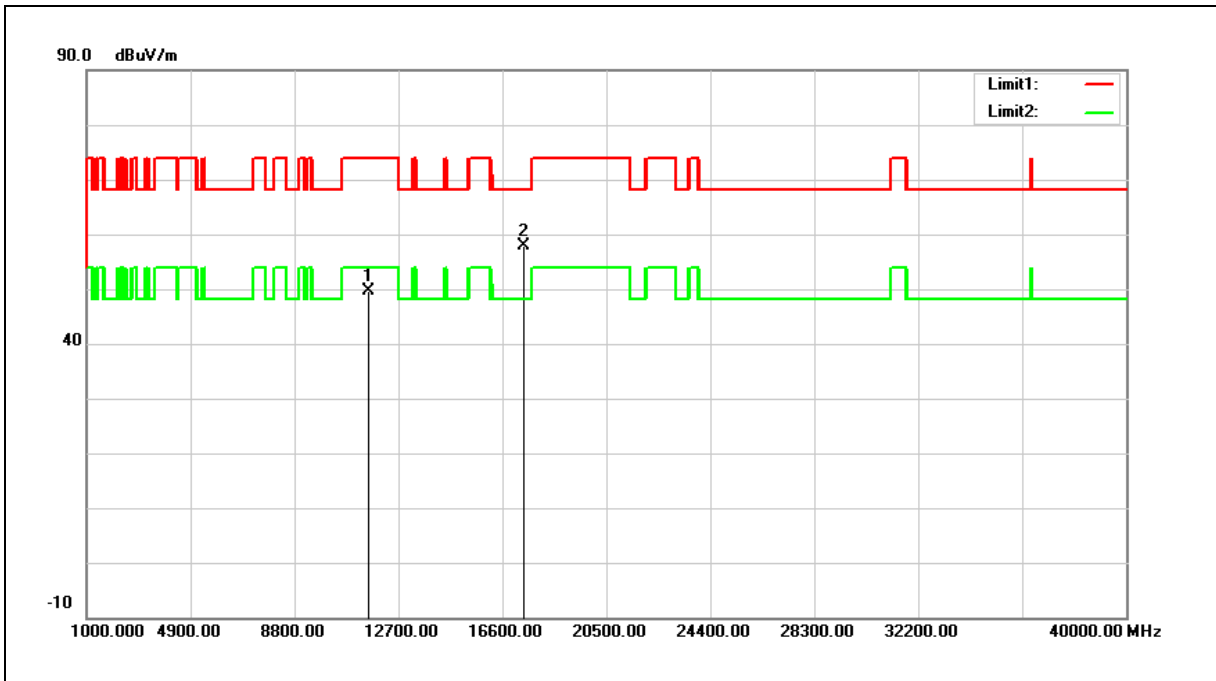

No.	Frequency (MHz)	Reading (dBuV)	Correct Factor (dB/m)	Result (dBuV/m)	Limit (dBuV/m)	Margin (dB)	Remark
1	11590.000	31.34	18.41	49.75	74.00	-24.25	peak
2	17385.000	32.88	25.10	57.98	68.20	-10.22	peak

Note:1.Result (dBuV/m) = Correct Factor (dB/m) + Reading(dBuV).

2.Correction factor (dB/m) = Antenna Factor (dB/m) + Cable loss (dB) – Pre-Amplifier gain (dB).

3.When the peak results are less than average limit, so not need to evaluate the average.

Standard:	FCC Part 15.407	Test Distance:	3 m
Test item:	Harmonic		
Frequency:	5210 MHz		
Mode:	Mode 10		
Ant.Polar.:	Horizontal		

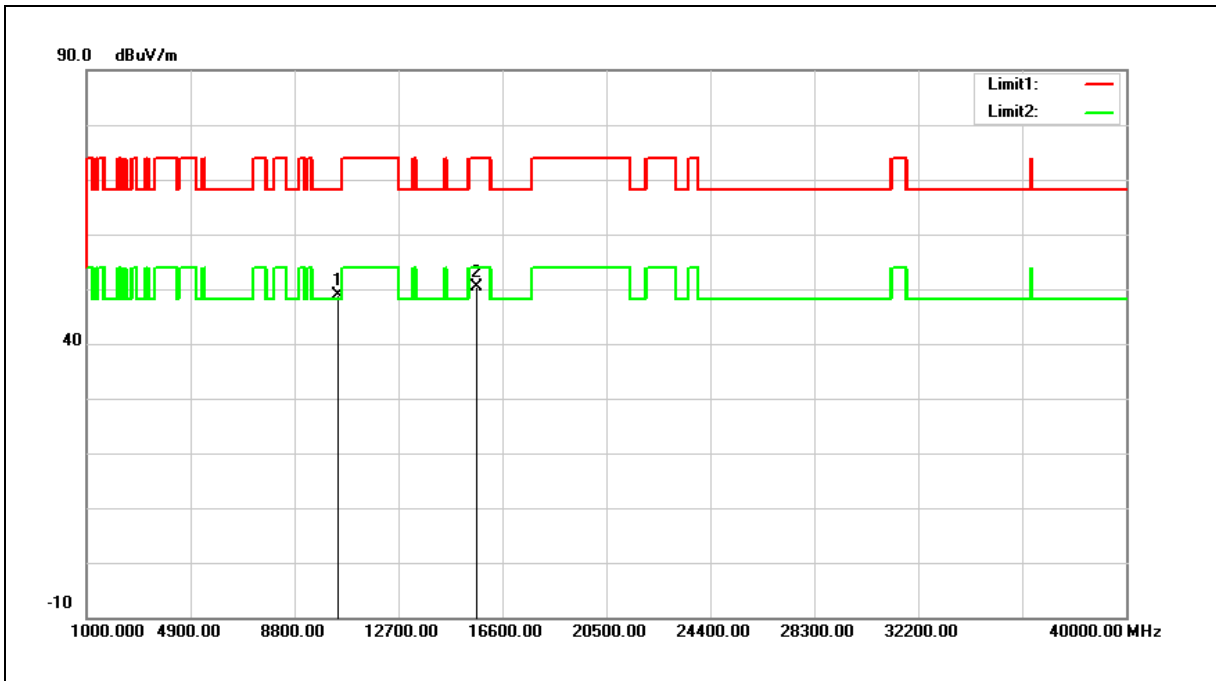

No.	Frequency (MHz)	Reading (dBuV)	Correct Factor (dB/m)	Result (dBuV/m)	Limit (dBuV/m)	Margin (dB)	Remark
1	10420.000	31.81	16.99	48.80	68.20	-19.40	peak
2	15630.000	32.18	18.25	50.43	74.00	-23.57	peak

Note:1.Result (dBuV/m) = Correct Factor (dB/m) + Reading(dBuV).

2.Correction factor (dB/m) = Antenna Factor (dB/m) + Cable loss (dB) – Pre-Amplifier gain (dB).

3.When the peak results are less than average limit, so not need to evaluate the average.

Standard:	FCC Part 15.407	Test Distance:	3 m
Test item:	Harmonic		
Frequency:	5210 MHz		
Mode:	Mode 10		
Ant.Polar.:	Vertical		

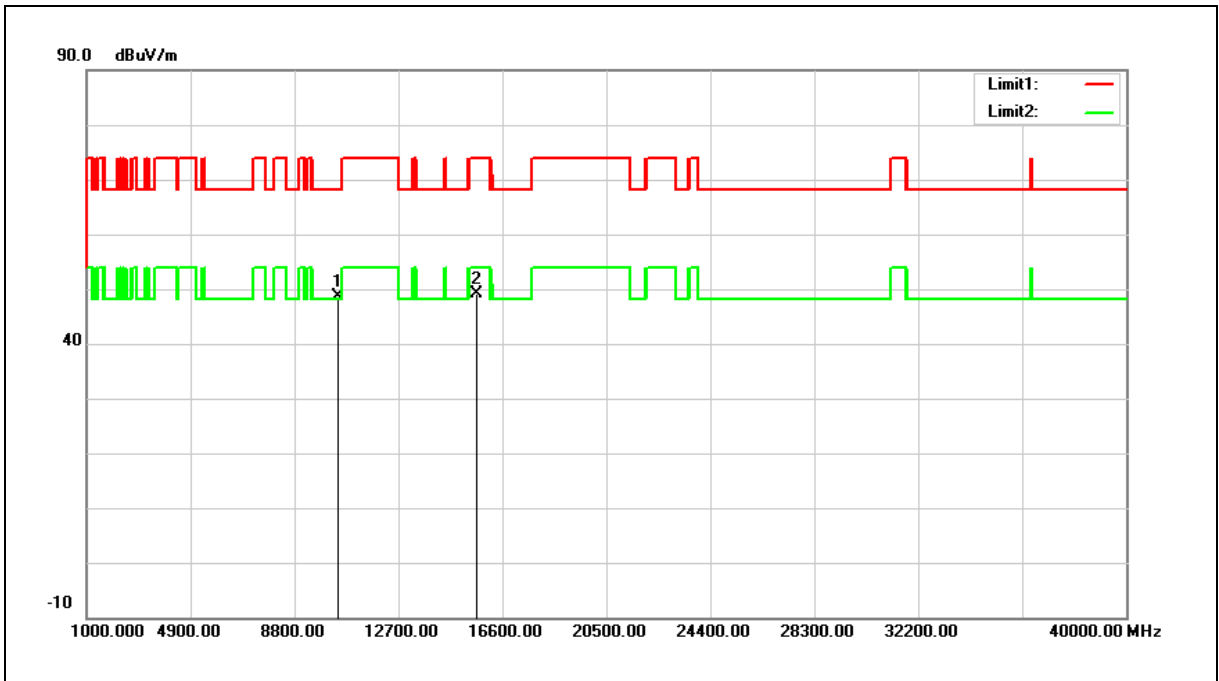

No.	Frequency (MHz)	Reading (dBuV)	Correct Factor (dB/m)	Result (dBuV/m)	Limit (dBuV/m)	Margin (dB)	Remark
1	10420.000	31.74	16.99	48.73	68.20	-19.47	peak
2	15630.000	30.87	18.25	49.12	74.00	-24.88	peak

Note:1.Result (dBuV/m) = Correct Factor (dB/m) + Reading(dBuV).

2.Correction factor (dB/m) = Antenna Factor (dB/m) + Cable loss (dB) – Pre-Amplifier gain (dB).

3.When the peak results are less than average limit, so not need to evaluate the average.

Standard:	FCC Part 15.407	Test Distance:	3 m
Test item:	Harmonic		
Frequency:	5290 MHz		
Mode:	Mode 10		
Ant.Polar.:	Horizontal		

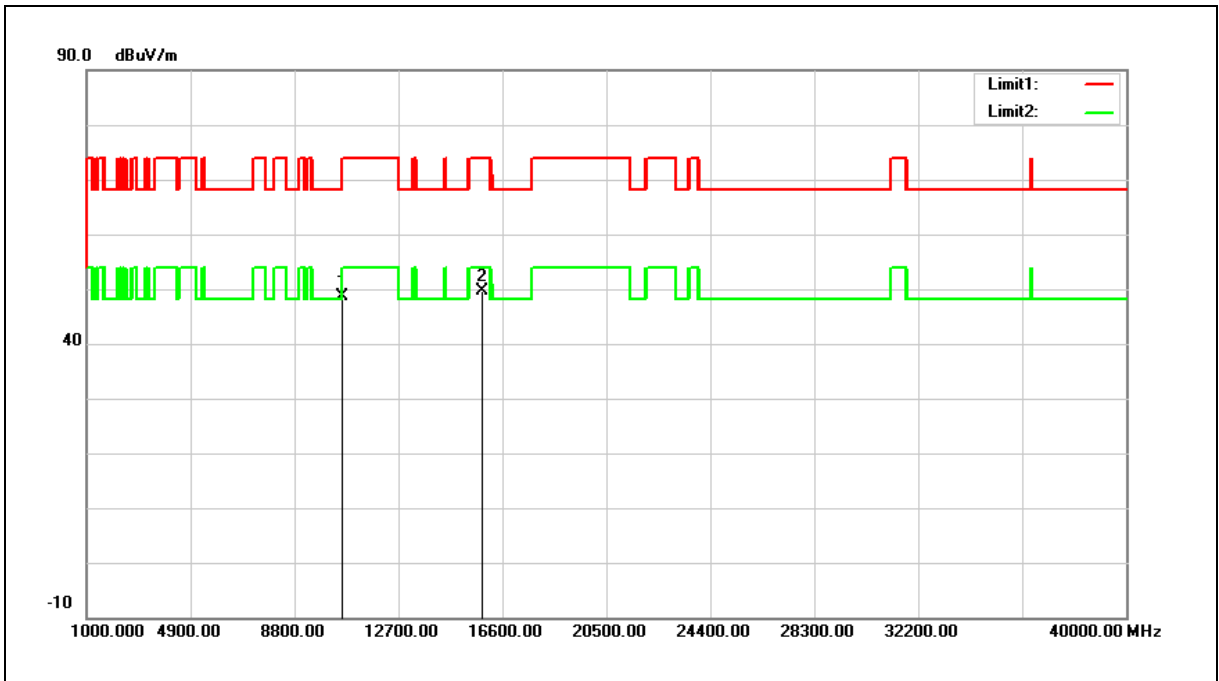

No.	Frequency (MHz)	Reading (dBuV)	Correct Factor (dB/m)	Result (dBuV/m)	Limit (dBuV/m)	Margin (dB)	Remark
1	10580.000	31.21	17.34	48.55	68.20	-19.65	peak
2	15870.000	32.18	17.57	49.75	74.00	-24.25	peak

Note:1.Result (dBuV/m) = Correct Factor (dB/m) + Reading(dBuV).

2.Correction factor (dB/m) = Antenna Factor (dB/m) + Cable loss (dB) – Pre-Amplifier gain (dB).

3.When the peak results are less than average limit, so not need to evaluate the average.

Standard:	FCC Part 15.407	Test Distance:	3 m
Test item:	Harmonic		
Frequency:	5290 MHz		
Mode:	Mode 10		
Ant.Polar.:	Vertical		

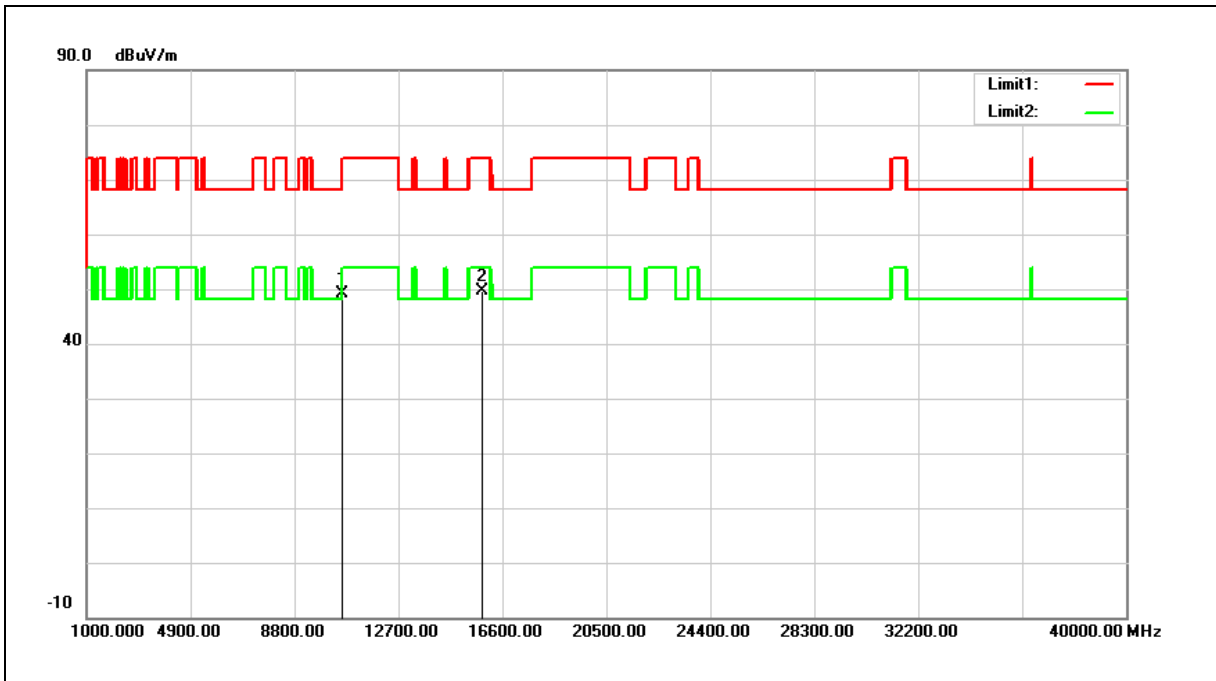

No.	Frequency (MHz)	Reading (dBuV)	Correct Factor (dB/m)	Result (dBuV/m)	Limit (dBuV/m)	Margin (dB)	Remark
1	10580.000	31.81	17.34	49.15	68.20	-19.05	peak
2	15870.000	31.97	17.57	49.54	74.00	-24.46	peak

Note:1.Result (dBuV/m) = Correct Factor (dB/m) + Reading(dBuV).

2.Correction factor (dB/m) = Antenna Factor (dB/m) + Cable loss (dB) – Pre-Amplifier gain (dB).

3.When the peak results are less than average limit, so not need to evaluate the average.

Standard:	FCC Part 15.407	Test Distance:	3 m
Test item:	Harmonic		
Frequency:	5530 MHz		
Mode:	Mode 10		
Ant.Polar.:	Horizontal		

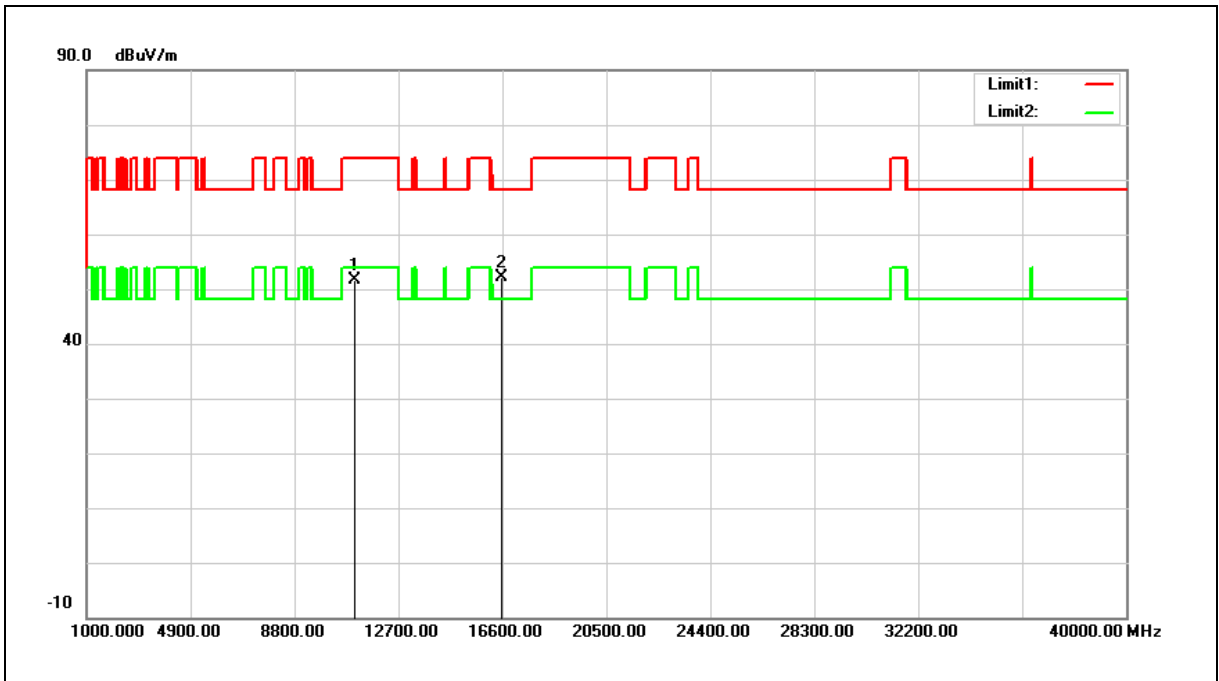

No.	Frequency (MHz)	Reading (dBuV)	Correct Factor (dB/m)	Result (dBuV/m)	Limit (dBuV/m)	Margin (dB)	Remark
1	11060.000	33.38	18.31	51.69	74.00	-22.31	peak
2	16590.000	31.81	20.37	52.18	68.20	-16.02	peak

Note:1.Result (dBuV/m) = Correct Factor (dB/m) + Reading(dBuV).

2.Correction factor (dB/m) = Antenna Factor (dB/m) + Cable loss (dB) – Pre-Amplifier gain (dB).

3.When the peak results are less than average limit, so not need to evaluate the average.

Standard:	FCC Part 15.407	Test Distance:	3 m
Test item:	Harmonic		
Frequency:	5530 MHz		
Mode:	Mode 10		
Ant.Polar.:	Vertical		

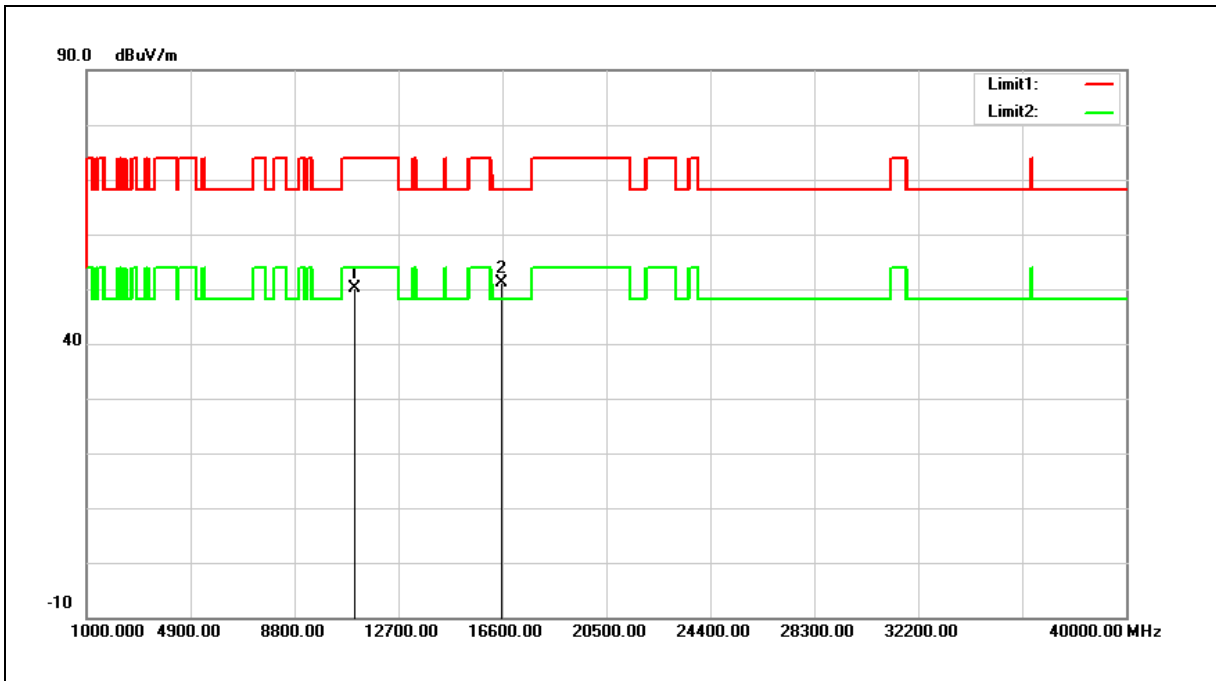

No.	Frequency (MHz)	Reading (dBuV)	Correct Factor (dB/m)	Result (dBuV/m)	Limit (dBuV/m)	Margin (dB)	Remark
1	11060.000	31.83	18.31	50.14	74.00	-23.86	peak
2	16590.000	30.69	20.37	51.06	68.20	-17.14	peak

Note:1.Result (dBuV/m) = Correct Factor (dB/m) + Reading(dBuV).

2.Correction factor (dB/m) = Antenna Factor (dB/m) + Cable loss (dB) – Pre-Amplifier gain (dB).

3.When the peak results are less than average limit, so not need to evaluate the average.

Standard:	FCC Part 15.407	Test Distance:	3 m
Test item:	Harmonic		
Frequency:	5610 MHz		
Mode:	Mode 10		
Ant.Polar.:	Horizontal		

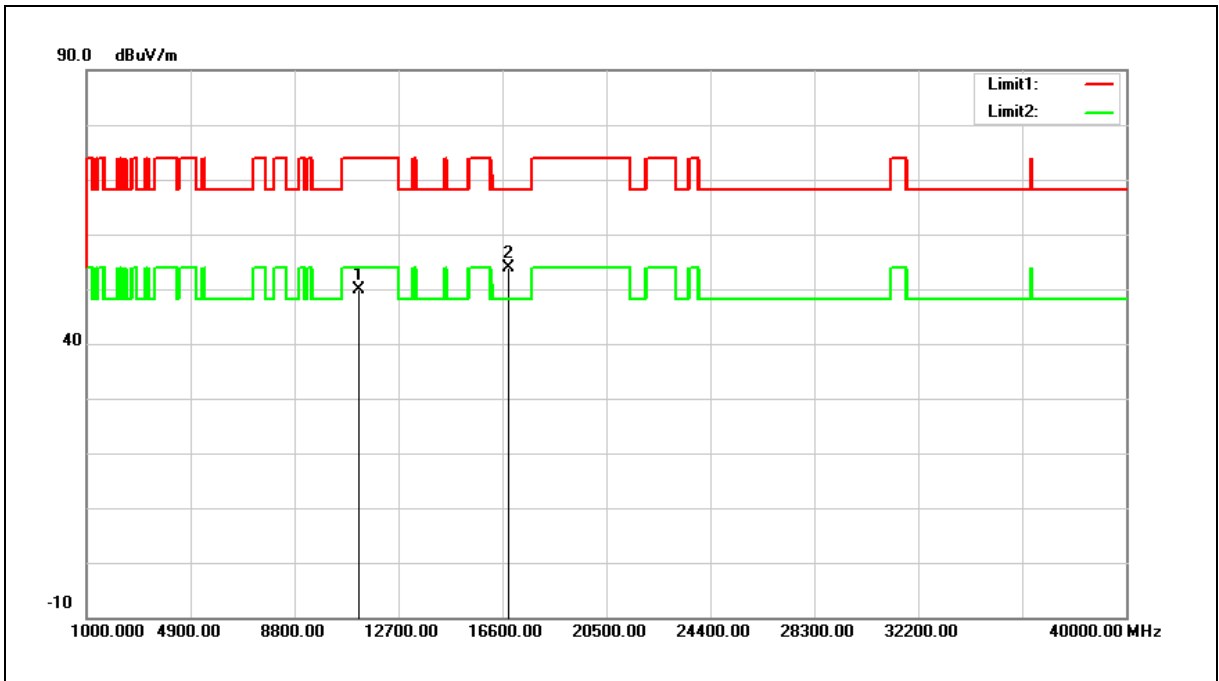

No.	Frequency (MHz)	Reading (dBuV)	Correct Factor (dB/m)	Result (dBuV/m)	Limit (dBuV/m)	Margin (dB)	Remark
1	11220.000	31.43	18.38	49.81	74.00	-24.19	peak
2	16830.000	31.85	21.91	53.76	68.20	-14.44	peak

Note:1.Result (dBuV/m) = Correct Factor (dB/m) + Reading(dBuV).

2.Correction factor (dB/m) = Antenna Factor (dB/m) + Cable loss (dB) – Pre-Amplifier gain (dB).

3.When the peak results are less than average limit, so not need to evaluate the average.

Standard:	FCC Part 15.407	Test Distance:	3 m
Test item:	Harmonic		
Frequency:	5610 MHz		
Mode:	Mode 10		
Ant.Polar.:	Vertical		

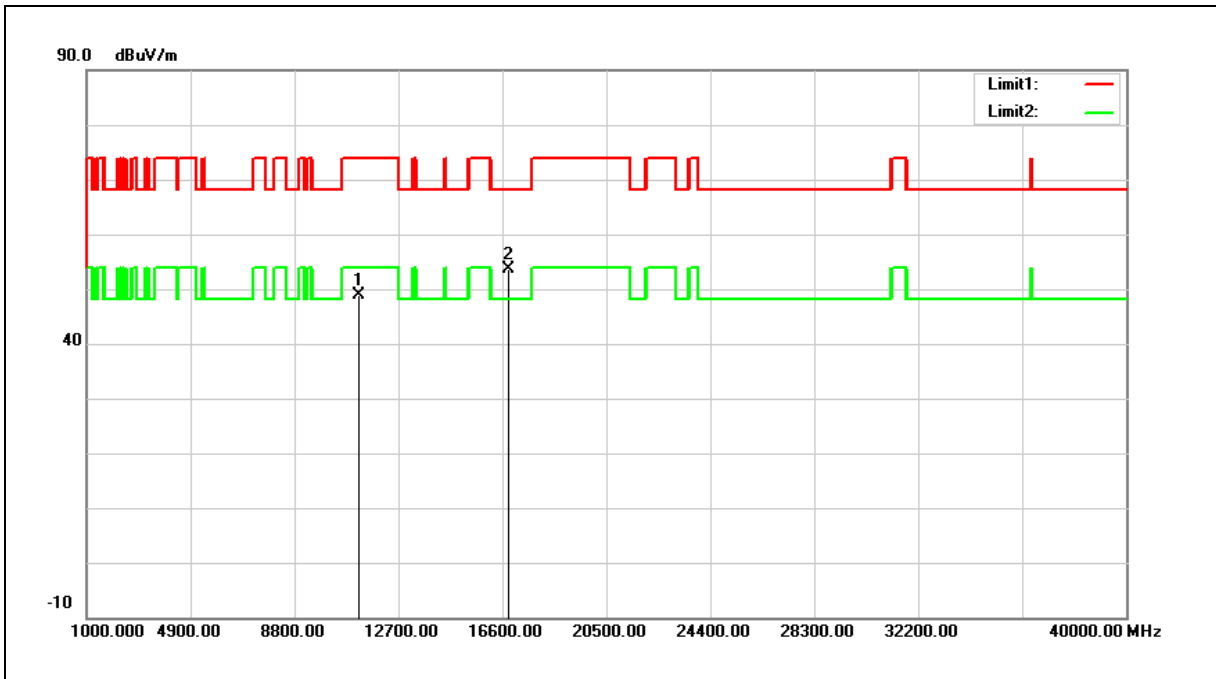

No.	Frequency (MHz)	Reading (dBuV)	Correct Factor (dB/m)	Result (dBuV/m)	Limit (dBuV/m)	Margin (dB)	Remark
1	11220.000	30.44	18.38	48.82	74.00	-25.18	peak
2	16830.000	31.83	21.91	53.74	68.20	-14.46	peak

Note:1.Result (dBuV/m) = Correct Factor (dB/m) + Reading(dBuV).

2.Correction factor (dB/m) = Antenna Factor (dB/m) + Cable loss (dB) – Pre-Amplifier gain (dB).

3.When the peak results are less than average limit, so not need to evaluate the average.

Standard:	FCC Part 15.407	Test Distance:	3 m
Test item:	Harmonic		
Frequency:	5690 MHz		
Mode:	Mode 10		
Ant.Polar.:	Horizontal		

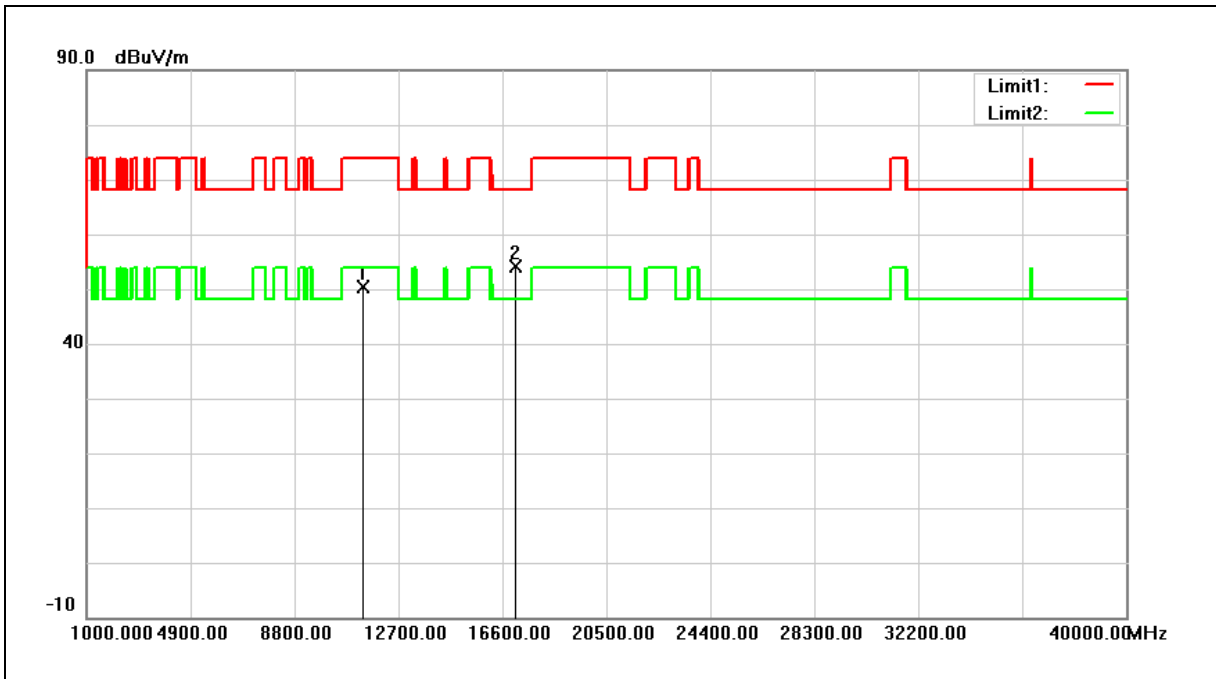

No.	Frequency (MHz)	Reading (dBuV)	Correct Factor (dB/m)	Result (dBuV/m)	Limit (dBuV/m)	Margin (dB)	Remark
1	11380.000	31.90	18.44	50.34	74.00	-23.66	peak
2	17070.000	30.79	23.40	54.19	68.20	-14.01	peak

Note:1.Result (dBuV/m) = Correct Factor (dB/m) + Reading(dBuV).

2.Correction factor (dB/m) = Antenna Factor (dB/m) + Cable loss (dB) – Pre-Amplifier gain (dB).

3.When the peak results are less than average limit, so not need to evaluate the average.

Standard:	FCC Part 15.407	Test Distance:	3 m
Test item:	Harmonic		
Frequency:	5690 MHz		
Mode:	Mode 10		
Ant.Polar.:	Vertical		

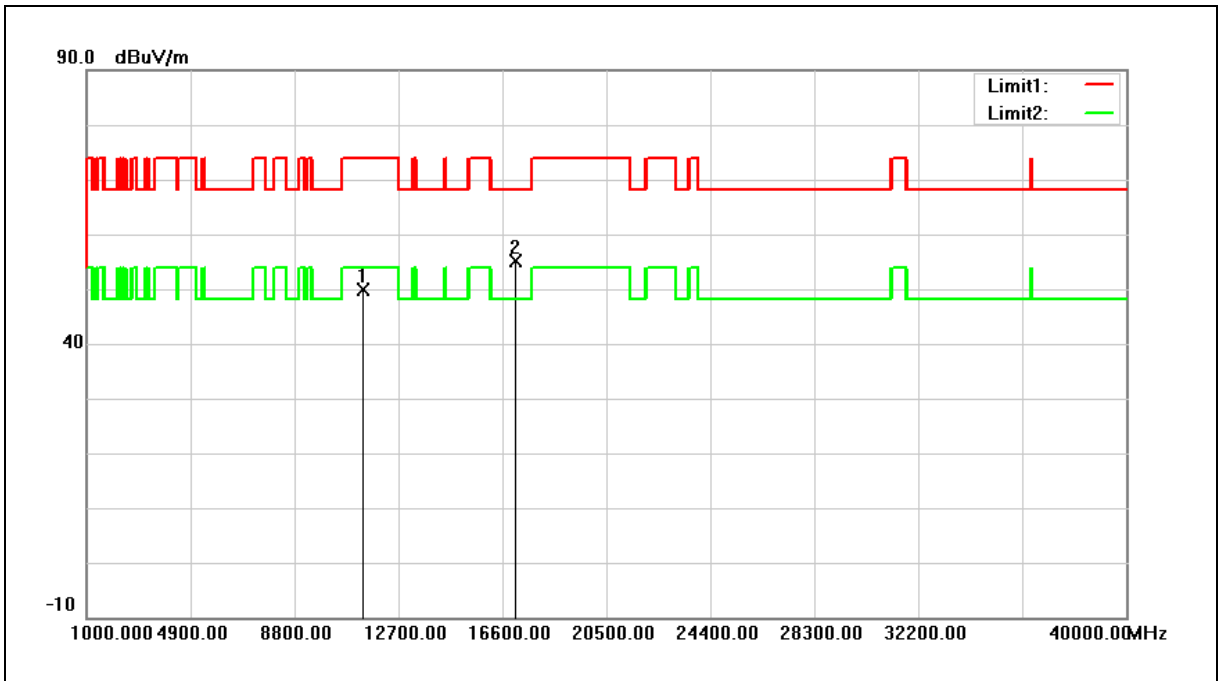

No.	Frequency (MHz)	Reading (dBuV)	Correct Factor (dB/m)	Result (dBuV/m)	Limit (dBuV/m)	Margin (dB)	Remark
1	11380.000	31.51	18.44	49.95	74.00	-24.05	peak
2	17070.000	31.81	23.40	55.21	68.20	-12.99	peak

Note:1.Result (dBuV/m) = Correct Factor (dB/m) + Reading(dBuV).

2.Correction factor (dB/m) = Antenna Factor (dB/m) + Cable loss (dB) – Pre-Amplifier gain (dB).

3.When the peak results are less than average limit, so not need to evaluate the average.

Standard:	FCC Part 15.407	Test Distance:	3 m
Test item:	Harmonic		
Frequency:	5775 MHz		
Mode:	Mode 10		
Ant.Polar.:	Horizontal		

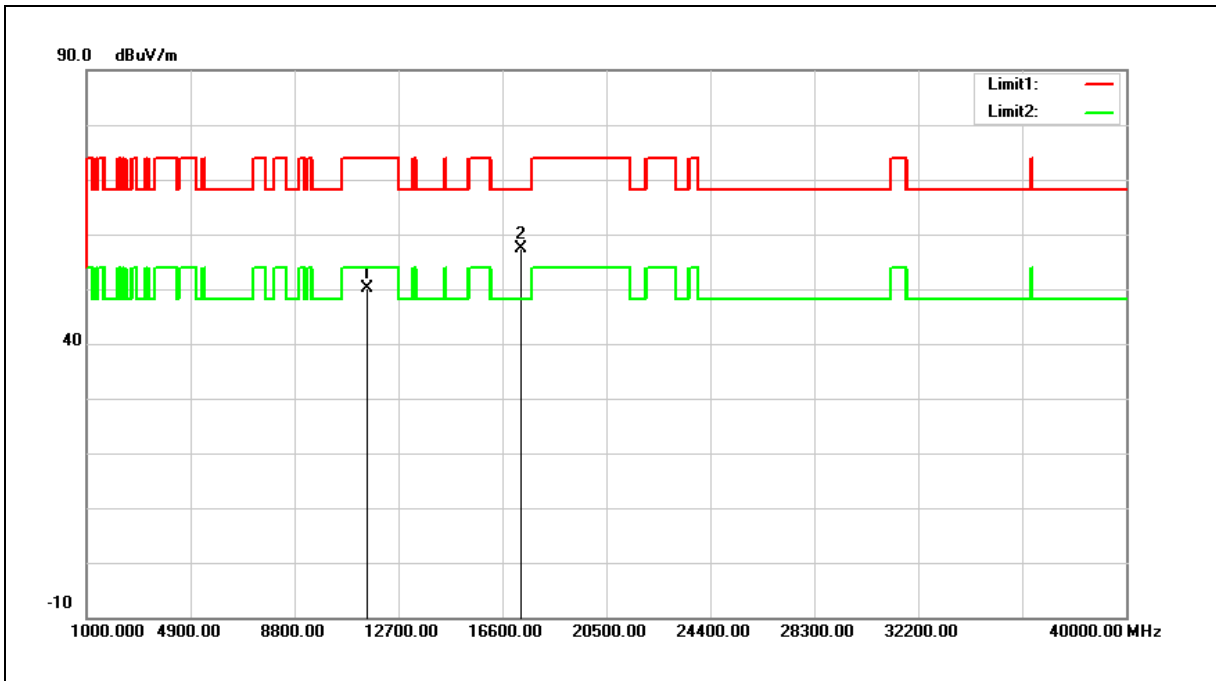

No.	Frequency (MHz)	Reading (dBuV)	Correct Factor (dB/m)	Result (dBuV/m)	Limit (dBuV/m)	Margin (dB)	Remark
1	11550.000	31.80	18.44	50.24	74.00	-23.76	peak
2	17325.000	32.47	24.79	57.26	68.20	-10.94	peak

Note:1.Result (dBuV/m) = Correct Factor (dB/m) + Reading(dBuV).

2.Correction factor (dB/m) = Antenna Factor (dB/m) + Cable loss (dB) – Pre-Amplifier gain (dB).

3.When the peak results are less than average limit, so not need to evaluate the average.

Standard:	FCC Part 15.407	Test Distance:	3 m
Test item:	Harmonic		
Frequency:	5775 MHz		
Mode:	Mode 10		
Ant.Polar.:	Vertical		

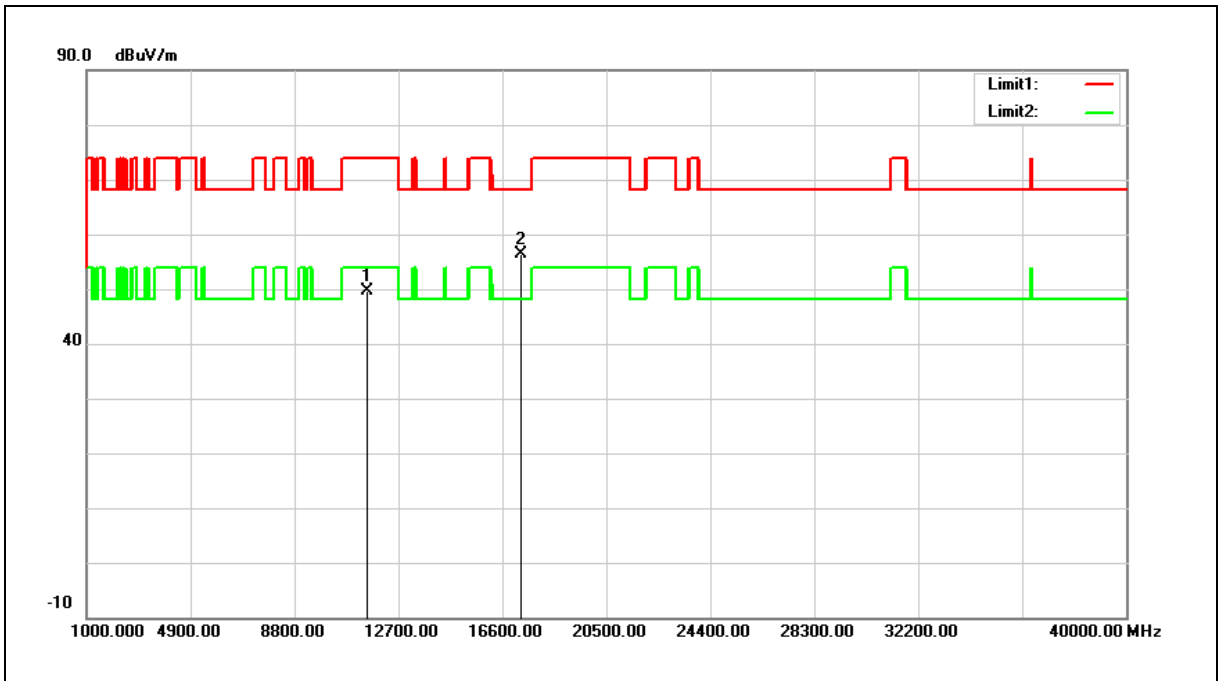

No.	Frequency (MHz)	Reading (dBuV)	Correct Factor (dB/m)	Result (dBuV/m)	Limit (dBuV/m)	Margin (dB)	Remark
1	11550.000	31.16	18.44	49.60	74.00	-24.40	peak
2	17325.000	31.52	24.79	56.31	68.20	-11.89	peak

Note:1.Result (dBuV/m) = Correct Factor (dB/m) + Reading(dBuV).

2.Correction factor (dB/m) = Antenna Factor (dB/m) + Cable loss (dB) – Pre-Amplifier gain (dB).

3.When the peak results are less than average limit, so not need to evaluate the average.

Band Edge

Peak

Standard:	FCC Part 15.407	Test Distance:	3 m
Test item:	Band edge		
Frequency:	5180 MHz		
Mode:	Mode 8		
Ant.Polar.:	Horizontal		

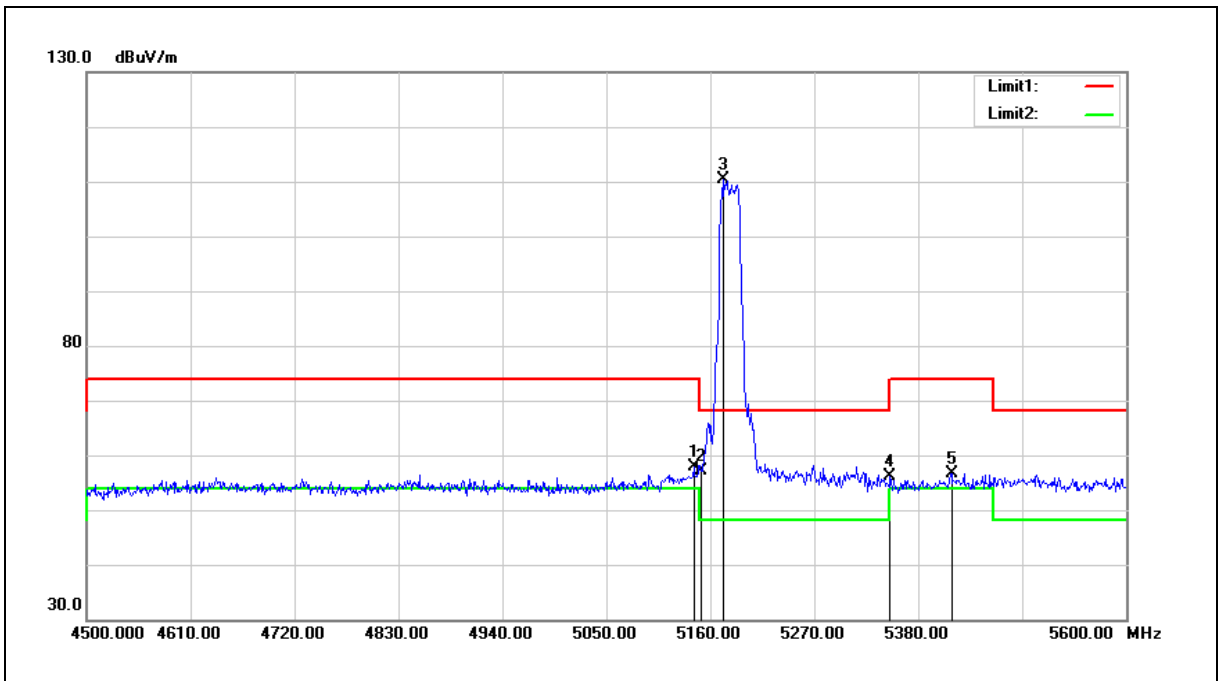

No.	Frequency (MHz)	Reading (dBuV)	Correct Factor (dB/m)	Result (dBuV/m)	Limit (dBuV/m)	Margin (dB)	Remark
1	5142.400	52.08	5.75	57.83	74.00	-16.17	peak
2	5150.000	51.26	5.75	57.01	74.00	-16.99	peak
3	5173.200	104.50	5.78	110.28	68.20	42.08	peak
4	5350.000	50.14	6.00	56.14	74.00	-17.86	peak
5	5415.200	50.51	6.08	56.59	74.00	-17.41	peak

Note:1.Result (dBuV/m) = Correct Factor (dB/m) + Reading(dBuV).

2.Correction factor (dB/m) = Antenna Factor (dB/m) + Cable loss (dB) – Pre-Amplifier gain (dB).

3.When the peak results are less than average limit, so not need to evaluate the average.

Standard:	FCC Part 15.407	Test Distance:	3 m
Test item:	Band edge		
Frequency:	5180 MHz		
Mode:	Mode 8		
Ant.Polar.:	Vertical		

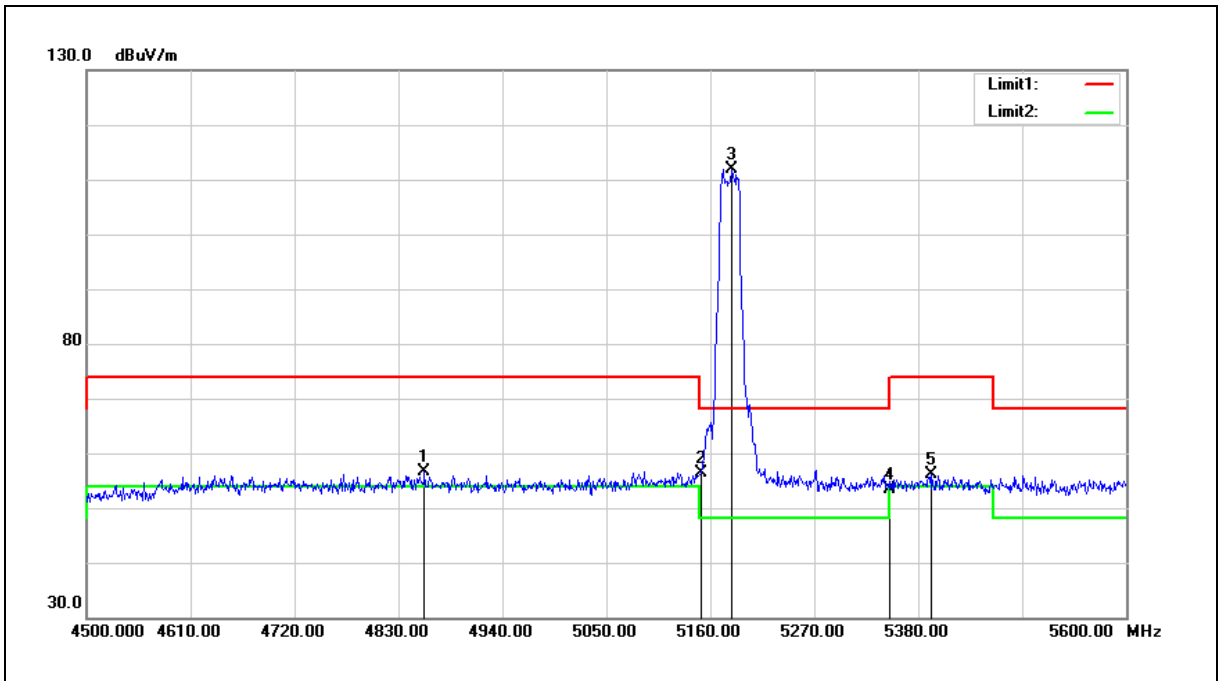

No.	Frequency (MHz)	Reading (dBuV)	Correct Factor (dB/m)	Result (dBuV/m)	Limit (dBuV/m)	Margin (dB)	Remark
1	4857.500	51.52	5.18	56.70	74.00	-17.30	peak
2	5150.000	50.71	5.75	56.46	74.00	-17.54	peak
3	5183.100	106.18	5.80	111.98	68.20	43.78	peak
4	5350.000	47.34	6.00	53.34	74.00	-20.66	peak
5	5394.300	50.07	6.06	56.13	74.00	-17.87	peak

Note:1.Result (dBuV/m) = Correct Factor (dB/m) + Reading(dBuV).

2.Correction factor (dB/m) = Antenna Factor (dB/m) + Cable loss (dB) – Pre-Amplifier gain (dB).

3.When the peak results are less than average limit, so not need to evaluate the average.

Standard:	FCC Part 15.407	Test Distance:	3 m
Test item:	Band edge		
Frequency:	5200 MHz		
Mode:	Mode 8		
Ant.Polar.:	Horizontal		

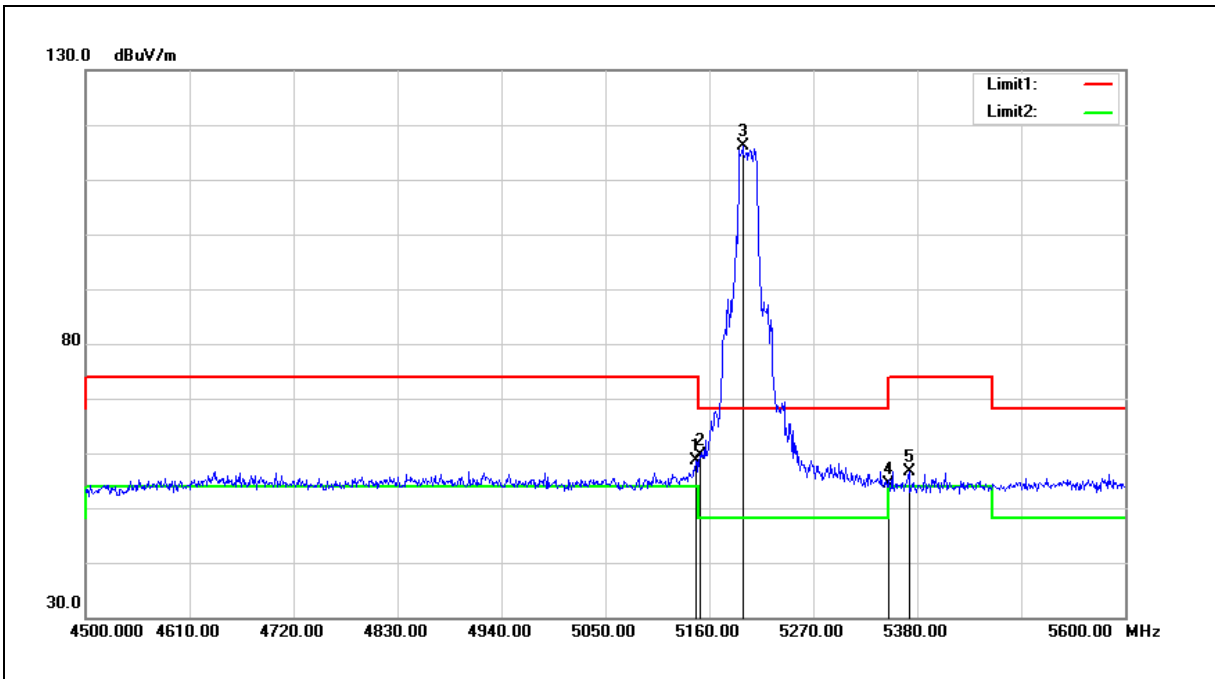

No.	Frequency (MHz)	Reading (dBuV)	Correct Factor (dB/m)	Result (dBuV/m)	Limit (dBuV/m)	Margin (dB)	Remark
1	5145.700	52.99	5.76	58.75	74.00	-15.25	peak
2	5150.000	53.97	5.75	59.72	74.00	-14.28	peak
3	5195.200	110.25	5.82	116.07	68.20	47.87	peak
4	5350.000	48.50	6.00	54.50	74.00	-19.50	peak
5	5371.200	50.56	6.03	56.59	74.00	-17.41	peak

Note:1.Result (dBuV/m) = Correct Factor (dB/m) + Reading(dBuV).

2.Correction factor (dB/m) = Antenna Factor (dB/m) + Cable loss (dB) – Pre-Amplifier gain (dB).

3.When the peak results are less than average limit, so not need to evaluate the average.

Standard:	FCC Part 15.407	Test Distance:	3 m
Test item:	Band edge		
Frequency:	5200 MHz		
Mode:	Mode 8		
Ant.Polar.:	Vertical		

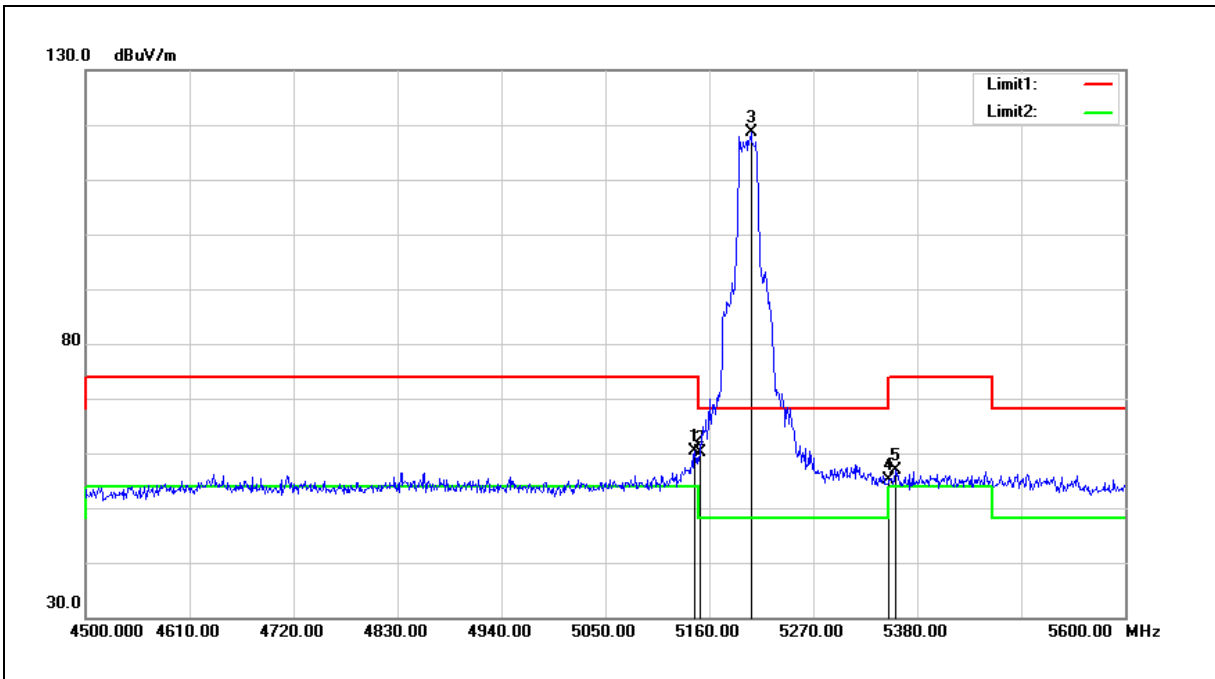

No.	Frequency (MHz)	Reading (dBuV)	Correct Factor (dB/m)	Result (dBuV/m)	Limit (dBuV/m)	Margin (dB)	Remark
1	5144.600	54.63	5.76	60.39	74.00	-13.61	peak
2	5150.000	54.44	5.75	60.19	74.00	-13.81	peak
3	5204.000	112.87	5.82	118.69	68.20	50.49	peak
4	5350.000	49.06	6.00	55.06	74.00	-18.94	peak
5	5356.900	50.81	6.01	56.82	74.00	-17.18	peak

Note:1.Result (dBuV/m) = Correct Factor (dB/m) + Reading(dBuV).

2.Correction factor (dB/m) = Antenna Factor (dB/m) + Cable loss (dB) – Pre-Amplifier gain (dB).

3.When the peak results are less than average limit, so not need to evaluate the average.

Standard:	FCC Part 15.407	Test Distance:	3 m
Test item:	Band edge		
Frequency:	5240 MHz		
Mode:	Mode 8		
Ant.Polar.:	Horizontal		

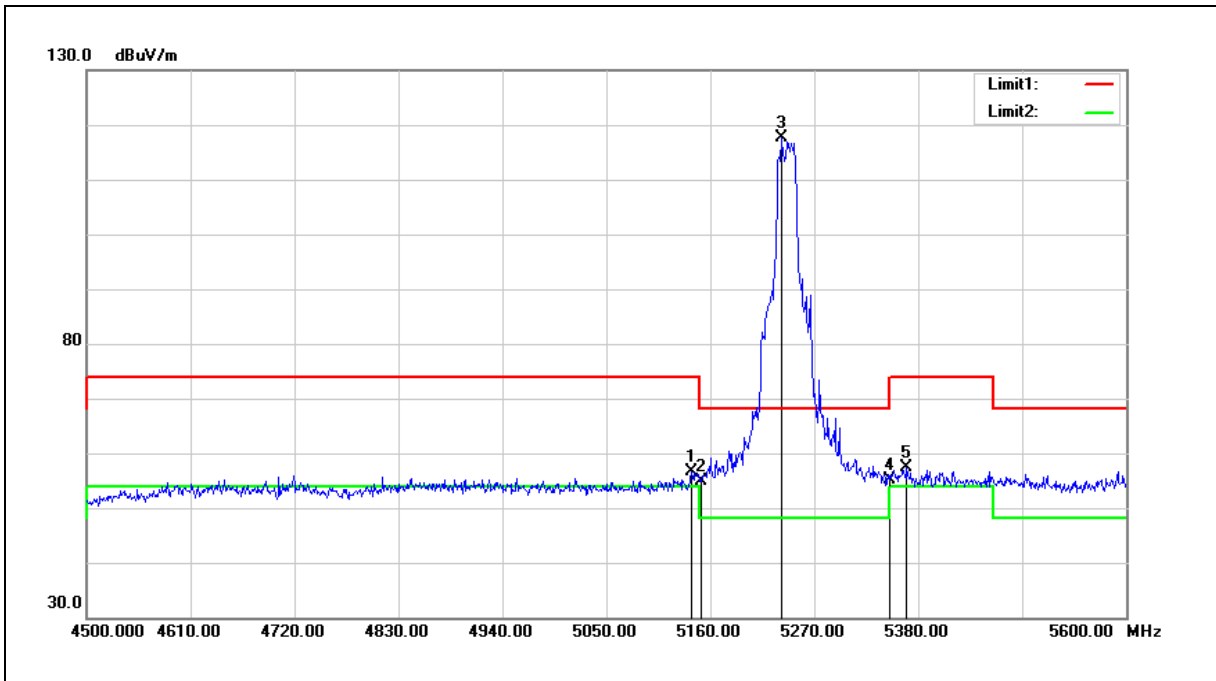

No.	Frequency (MHz)	Reading (dBuV)	Correct Factor (dB/m)	Result (dBuV/m)	Limit (dBuV/m)	Margin (dB)	Remark
1	5140.200	50.94	5.75	56.69	74.00	-17.31	peak
2	5150.000	49.24	5.75	54.99	74.00	-19.01	peak
3	5234.800	111.66	5.87	117.53	68.20	49.33	peak
4	5350.000	49.18	6.00	55.18	74.00	-18.82	peak
5	5367.900	51.31	6.02	57.33	74.00	-16.67	peak

Note:1.Result (dBuV/m) = Correct Factor (dB/m) + Reading(dBuV).

2.Correction factor (dB/m) = Antenna Factor (dB/m) + Cable loss (dB) – Pre-Amplifier gain (dB).

3.When the peak results are less than average limit, so not need to evaluate the average.

Standard:	FCC Part 15.407	Test Distance:	3 m
Test item:	Band edge		
Frequency:	5240 MHz		
Mode:	Mode 8		
Ant.Polar.:	Vertical		

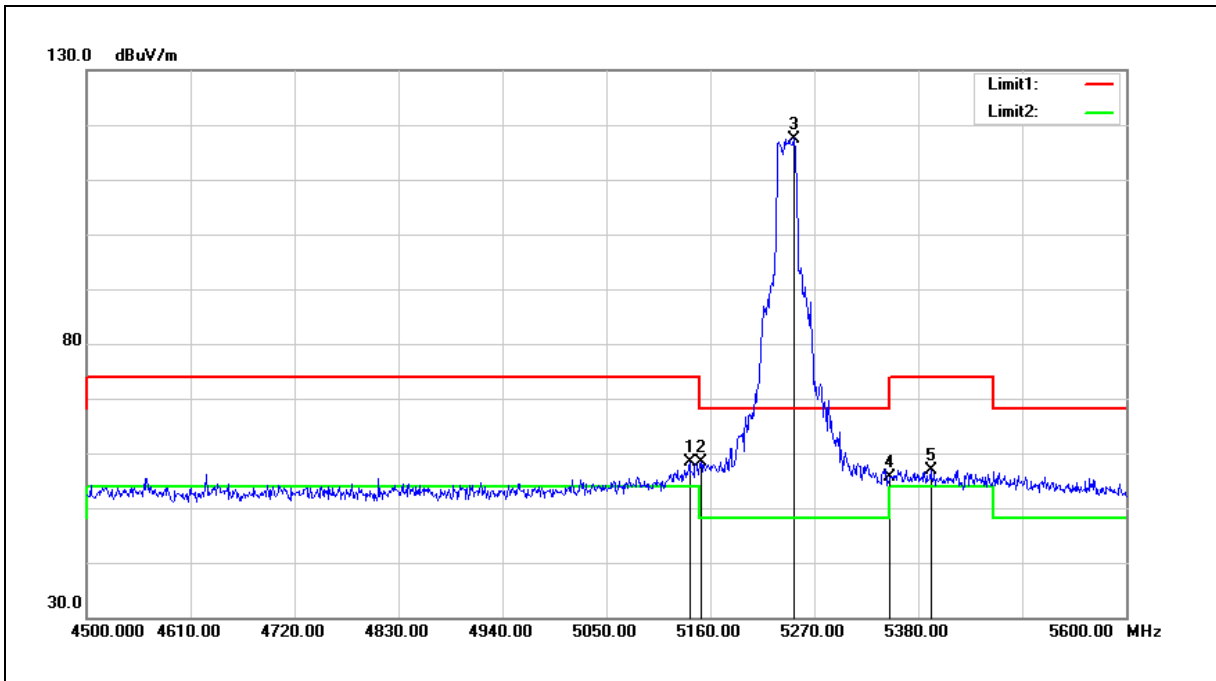

No.	Frequency (MHz)	Reading (dBuV)	Correct Factor (dB/m)	Result (dBuV/m)	Limit (dBuV/m)	Margin (dB)	Remark
1	5138.000	52.68	5.74	58.42	74.00	-15.58	peak
2	5150.000	52.73	5.75	58.48	74.00	-15.52	peak
3	5248.000	111.62	5.88	117.50	68.20	49.30	peak
4	5350.000	49.67	6.00	55.67	74.00	-18.33	peak
5	5393.200	50.90	6.05	56.95	74.00	-17.05	peak

Note:1.Result (dBuV/m) = Correct Factor (dB/m) + Reading(dBuV).

2.Correction factor (dB/m) = Antenna Factor (dB/m) + Cable loss (dB) – Pre-Amplifier gain (dB).

3.When the peak results are less than average limit, so not need to evaluate the average.

Standard:	FCC Part 15.407	Test Distance:	3 m
Test item:	Band edge		
Frequency:	5260 MHz		
Mode:	Mode 8		
Ant.Polar.:	Horizontal		

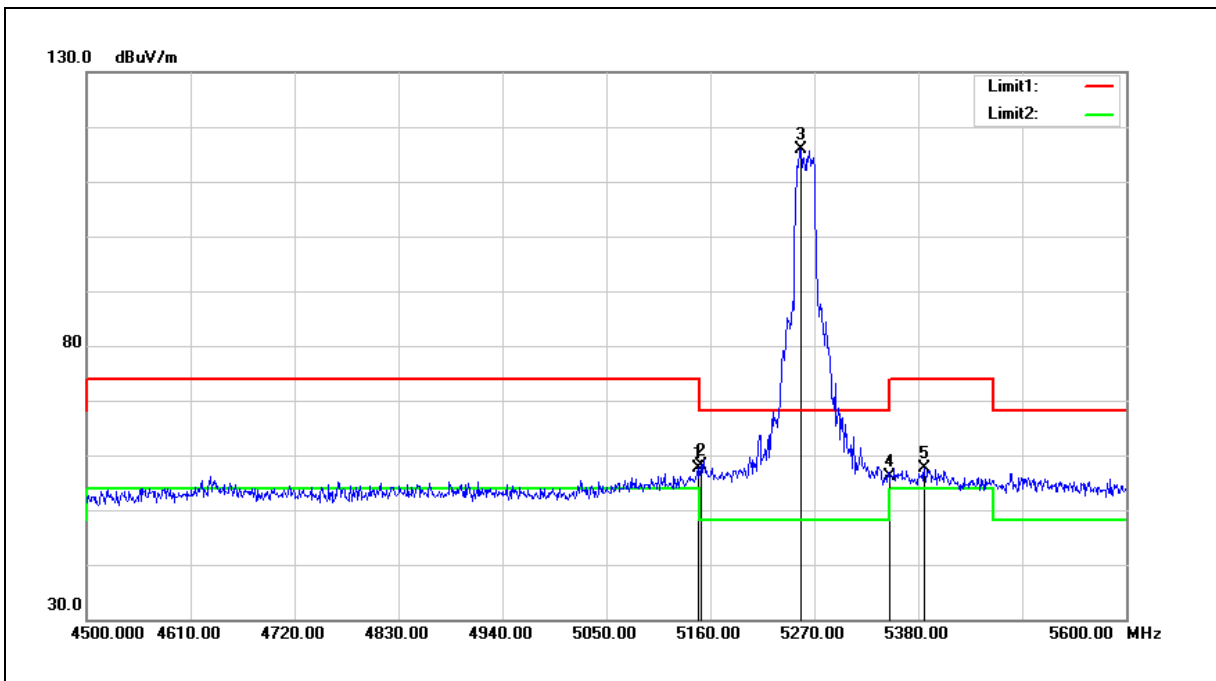

No.	Frequency (MHz)	Reading (dBuV)	Correct Factor (dB/m)	Result (dBuV/m)	Limit (dBuV/m)	Margin (dB)	Remark
1	5146.800	51.79	5.76	57.55	74.00	-16.45	peak
2	5150.000	52.29	5.75	58.04	74.00	-15.96	peak
3	5255.700	110.01	5.88	115.89	68.20	47.69	peak
4	5350.000	50.07	6.00	56.07	74.00	-17.93	peak
5	5386.600	51.59	6.05	57.64	74.00	-16.36	peak

Note:1.Result (dBuV/m) = Correct Factor (dB/m) + Reading(dBuV).

2.Correction factor (dB/m) = Antenna Factor (dB/m) + Cable loss (dB) – Pre-Amplifier gain (dB).

3.When the peak results are less than average limit, so not need to evaluate the average.

Standard:	FCC Part 15.407	Test Distance:	3 m
Test item:	Band edge		
Frequency:	5260 MHz		
Mode:	Mode 8		
Ant.Polar.:	Vertical		

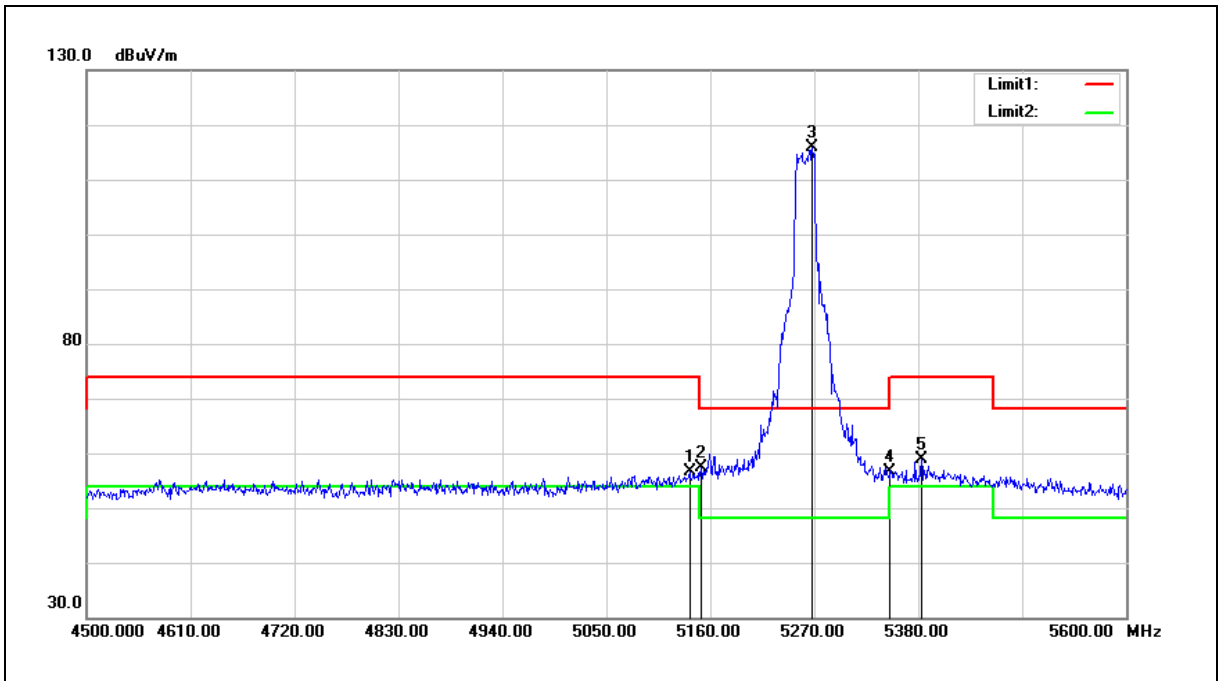

No.	Frequency (MHz)	Reading (dBuV)	Correct Factor (dB/m)	Result (dBuV/m)	Limit (dBuV/m)	Margin (dB)	Remark
1	5138.000	50.90	5.74	56.64	74.00	-17.36	peak
2	5150.000	51.57	5.75	57.32	74.00	-16.68	peak
3	5267.800	109.94	5.89	115.83	68.20	47.63	peak
4	5350.000	50.73	6.00	56.73	74.00	-17.27	peak
5	5383.300	52.85	6.05	58.90	74.00	-15.10	peak

Note:1.Result (dBuV/m) = Correct Factor (dB/m) + Reading(dBuV).

2.Correction factor (dB/m) = Antenna Factor (dB/m) + Cable loss (dB) – Pre-Amplifier gain (dB).

3.When the peak results are less than average limit, so not need to evaluate the average.

Standard:	FCC Part 15.407	Test Distance:	3 m
Test item:	Band edge		
Frequency:	5280 MHz		
Mode:	Mode 8		
Ant.Polar.:	Horizontal		

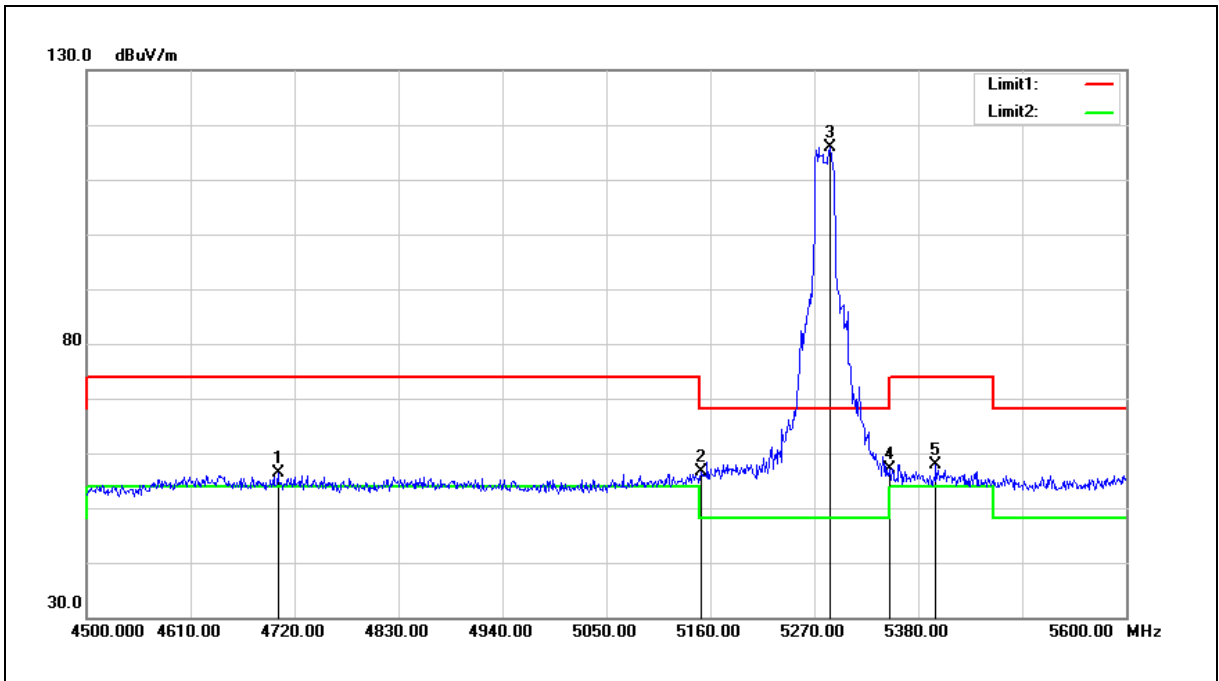

No.	Frequency (MHz)	Reading (dBuV)	Correct Factor (dB/m)	Result (dBuV/m)	Limit (dBuV/m)	Margin (dB)	Remark
1	4702.400	51.56	4.75	56.31	74.00	-17.69	peak
2	5150.000	50.93	5.75	56.68	74.00	-17.32	peak
3	5286.500	109.94	5.92	115.86	68.20	47.66	peak
4	5350.000	51.19	6.00	57.19	74.00	-16.81	peak
5	5398.700	51.86	6.07	57.93	74.00	-16.07	peak

Note:1.Result (dBuV/m) = Correct Factor (dB/m) + Reading(dBuV).

2.Correction factor (dB/m) = Antenna Factor (dB/m) + Cable loss (dB) – Pre-Amplifier gain (dB).

3.When the peak results are less than average limit, so not need to evaluate the average.

Standard:	FCC Part 15.407	Test Distance:	3 m
Test item:	Band edge		
Frequency:	5280 MHz		
Mode:	Mode 8		
Ant.Polar.:	Vertical		

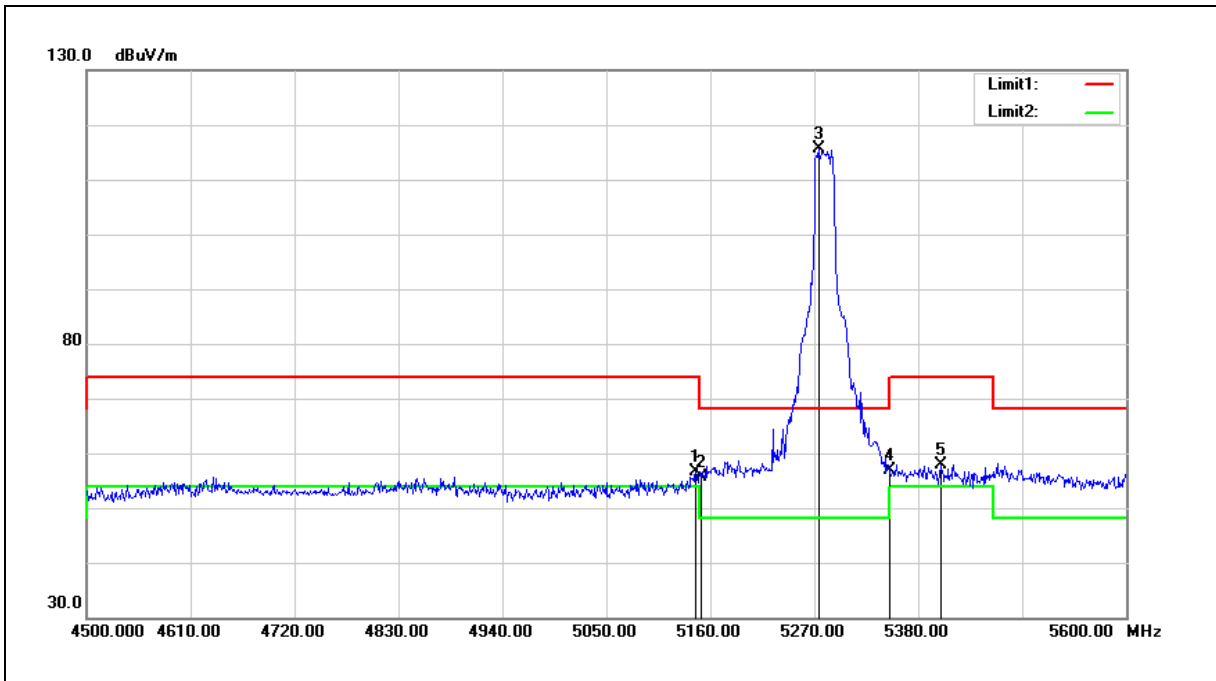

No.	Frequency (MHz)	Reading (dBuV)	Correct Factor (dB/m)	Result (dBuV/m)	Limit (dBuV/m)	Margin (dB)	Remark
1	5144.600	50.88	5.76	56.64	74.00	-17.36	peak
2	5150.000	49.78	5.75	55.53	74.00	-18.47	peak
3	5274.400	109.66	5.91	115.57	68.20	47.37	peak
4	5350.000	50.92	6.00	56.92	74.00	-17.08	peak
5	5404.200	51.88	6.07	57.95	74.00	-16.05	peak

Note:1.Result (dBuV/m) = Correct Factor (dB/m) + Reading(dBuV).

2.Correction factor (dB/m) = Antenna Factor (dB/m) + Cable loss (dB) – Pre-Amplifier gain (dB).

3.When the peak results are less than average limit, so not need to evaluate the average.

Standard:	FCC Part 15.407	Test Distance:	3 m
Test item:	Band edge		
Frequency:	5320 MHz		
Mode:	Mode 8		
Ant.Polar.:	Horizontal		

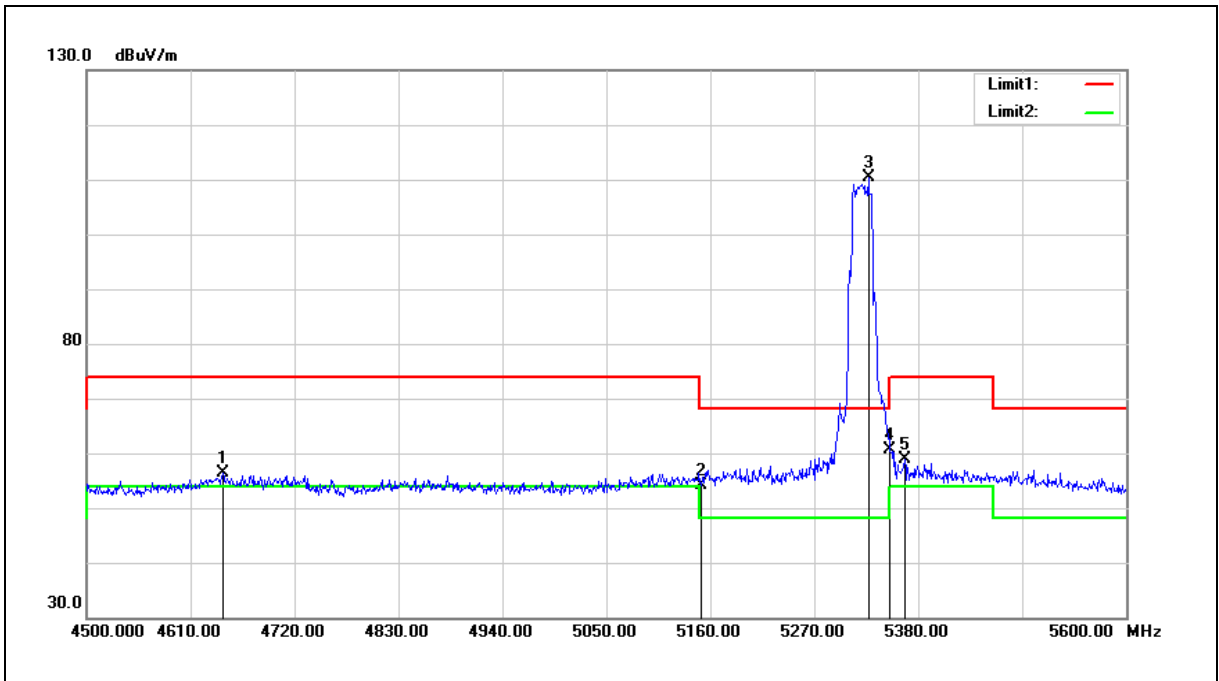

No.	Frequency (MHz)	Reading (dBuV)	Correct Factor (dB/m)	Result (dBuV/m)	Limit (dBuV/m)	Margin (dB)	Remark
1	4644.100	51.80	4.60	56.40	74.00	-17.60	peak
2	5150.000	48.30	5.75	54.05	74.00	-19.95	peak
3	5327.200	104.29	5.98	110.27	68.20	42.07	peak
4	5350.000	54.59	6.00	60.59	74.00	-13.41	peak
5	5365.700	52.88	6.02	58.90	74.00	-15.10	peak

Note:1.Result (dBuV/m) = Correct Factor (dB/m) + Reading(dBuV).

2.Correction factor (dB/m) = Antenna Factor (dB/m) + Cable loss (dB) – Pre-Amplifier gain (dB).

3.When the peak results are less than average limit, so not need to evaluate the average.

Standard:	FCC Part 15.407	Test Distance:	3 m
Test item:	Band edge		
Frequency:	5320 MHz		
Mode:	Mode 8		
Ant.Polar.:	Vertical		

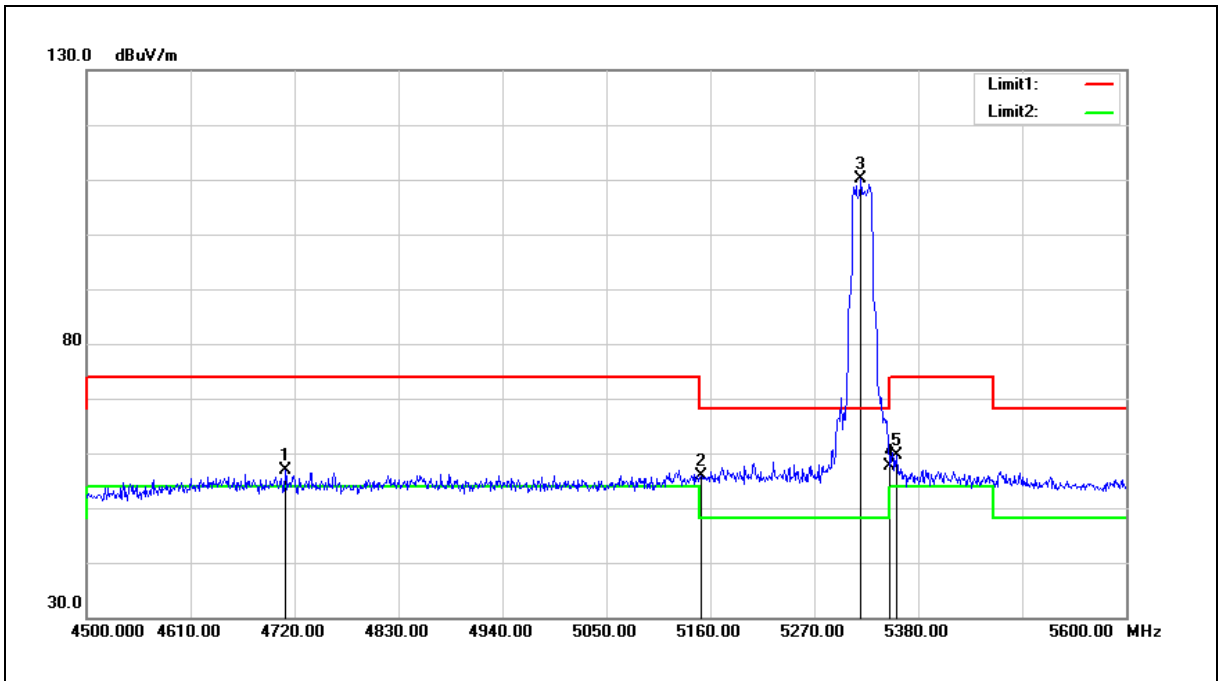

No.	Frequency (MHz)	Reading (dBuV)	Correct Factor (dB/m)	Result (dBuV/m)	Limit (dBuV/m)	Margin (dB)	Remark
1	4710.100	51.99	4.78	56.77	74.00	-17.23	peak
2	5150.000	50.23	5.75	55.98	74.00	-18.02	peak
3	5319.500	104.27	5.97	110.24	68.20	42.04	peak
4	5350.000	51.57	6.00	57.57	74.00	-16.43	peak
5	5356.900	53.71	6.01	59.72	74.00	-14.28	peak

Note:1.Result (dBuV/m) = Correct Factor (dB/m) + Reading(dBuV).

2.Correction factor (dB/m) = Antenna Factor (dB/m) + Cable loss (dB) – Pre-Amplifier gain (dB).

3.When the peak results are less than average limit, so not need to evaluate the average.

Standard:	FCC Part 15.407	Test Distance:	3 m
Test item:	Band edge		
Frequency:	5500 MHz		
Mode:	Mode 8		
Ant.Polar.:	Horizontal		

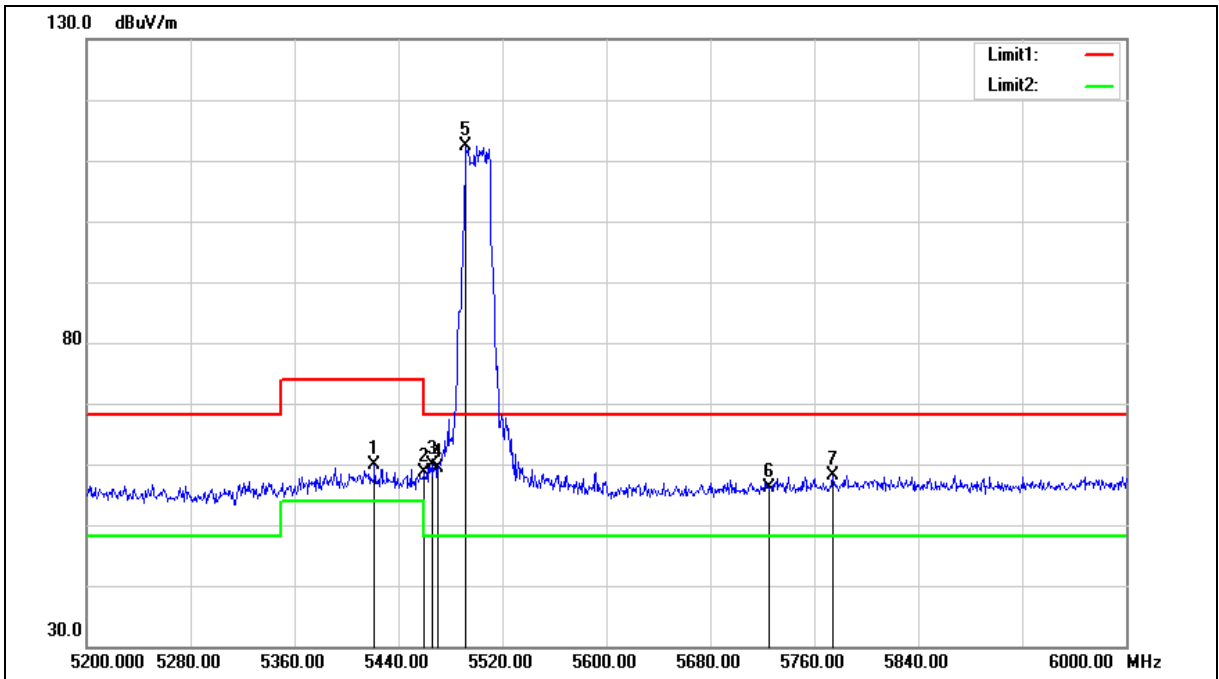

Standard:	FCC Part 15.407	Test Distance:	3 m
Test item:	Band edge		
Frequency:	5500 MHz		
Mode:	Mode 8		
Ant.Polar.:	Horizontal		

No.	Frequency (MHz)	Reading (dBuV)	Correct Factor (dB/m)	Result (dBuV/m)	Limit (dBuV/m)	Margin (dB)	Remark
1	5421.600	53.66	6.10	59.76	74.00	-14.24	peak
2	5460.000	52.41	6.14	58.55	74.00	-15.45	peak
3	5465.600	53.78	6.14	59.92	68.20	-8.28	peak
4	5470.000	53.34	6.15	59.49	68.20	-8.71	peak
5	5492.000	106.22	6.18	112.40	68.20	44.20	peak
6	5725.000	49.38	6.76	56.14	68.20	-12.06	peak
7	5774.400	51.25	6.86	58.11	68.20	-10.09	peak

Note:1.Result (dBuV/m) = Correct Factor (dB/m) + Reading(dBuV).

2.Correction factor (dB/m) = Antenna Factor (dB/m) + Cable loss (dB) – Pre-Amplifier gain (dB).

3.When the peak results are less than average limit, so not need to evaluate the average.

Standard:	FCC Part 15.407	Test Distance:	3 m
Test item:	Band edge		
Frequency:	5500 MHz		
Mode:	Mode 8		
Ant.Polar.:	Vertical		

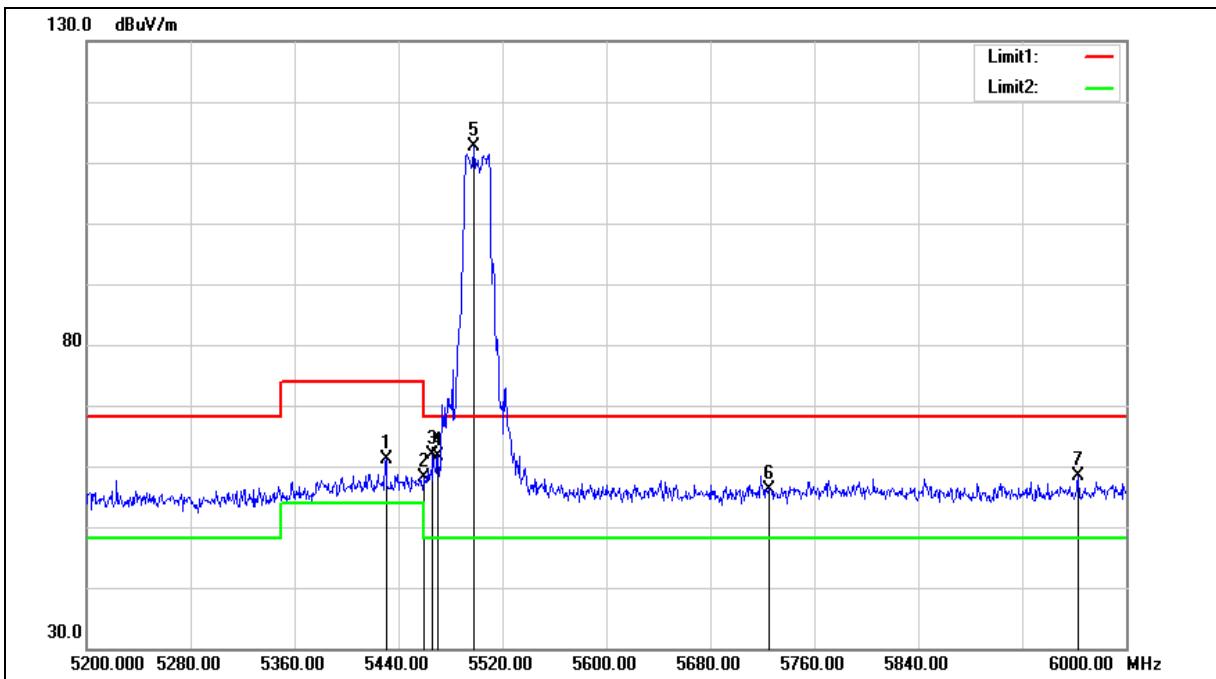

Standard:	FCC Part 15.407	Test Distance:	3 m
Test item:	Band edge		
Frequency:	5500 MHz		
Mode:	Mode 8		
Ant.Polar.:	Vertical		

No.	Frequency (MHz)	Reading (dBuV)	Correct Factor (dB/m)	Result (dBuV/m)	Limit (dBuV/m)	Margin (dB)	Remark
1	5430.400	55.14	6.10	61.24	74.00	-12.76	peak
2	5460.000	51.87	6.14	58.01	74.00	-15.99	peak
3	5466.400	55.65	6.14	61.79	68.20	-6.41	peak
4	5470.000	55.54	6.15	61.69	68.20	-6.51	peak
5	5497.600	106.54	6.19	112.73	68.20	44.53	peak
6	5725.000	49.30	6.76	56.06	68.20	-12.14	peak
7	5963.200	50.93	7.34	58.27	68.20	-9.93	peak

Note:1.Result (dBuV/m) = Correct Factor (dB/m) + Reading(dBuV).

2.Correction factor (dB/m) = Antenna Factor (dB/m) + Cable loss (dB) – Pre-Amplifier gain (dB).

3.When the peak results are less than average limit, so not need to evaluate the average.

Standard:	FCC Part 15.407	Test Distance:	3 m
Test item:	Band edge		
Frequency:	5560 MHz		
Mode:	Mode 8		
Ant.Polar.:	Horizontal		

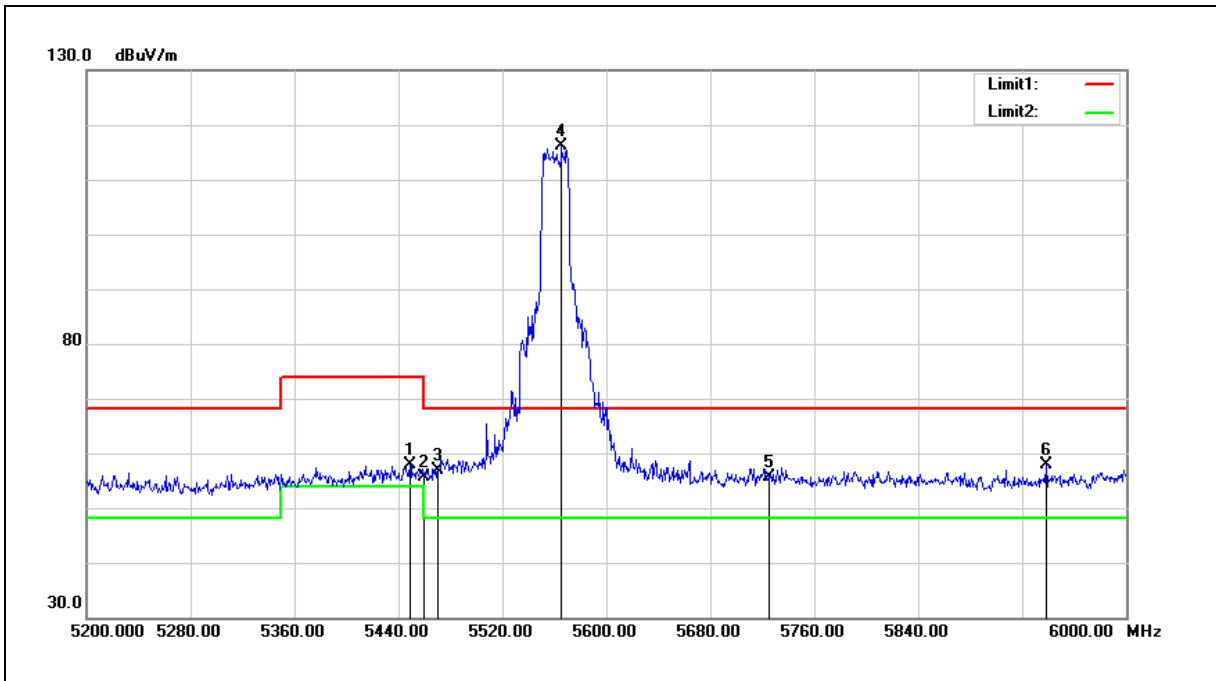

No.	Frequency (MHz)	Reading (dBuV)	Correct Factor (dB/m)	Result (dBuV/m)	Limit (dBuV/m)	Margin (dB)	Remark
1	5448.800	51.78	6.13	57.91	74.00	-16.09	peak
2	5460.000	49.49	6.14	55.63	74.00	-18.37	peak
3	5470.000	50.74	6.15	56.89	68.20	-11.31	peak
4	5565.600	109.84	6.35	116.19	68.20	47.99	peak
5	5725.000	48.83	6.76	55.59	68.20	-12.61	peak
6	5938.400	50.55	7.28	57.83	68.20	-10.37	peak

Note:1.Result (dBuV/m) = Correct Factor (dB/m) + Reading(dBuV).

2.Correction factor (dB/m) = Antenna Factor (dB/m) + Cable loss (dB) – Pre-Amplifier gain (dB).

3.When the peak results are less than average limit, so not need to evaluate the average.

Standard:	FCC Part 15.407	Test Distance:	3 m
Test item:	Band edge		
Frequency:	5560 MHz		
Mode:	Mode 8		
Ant.Polar.:	Vertical		

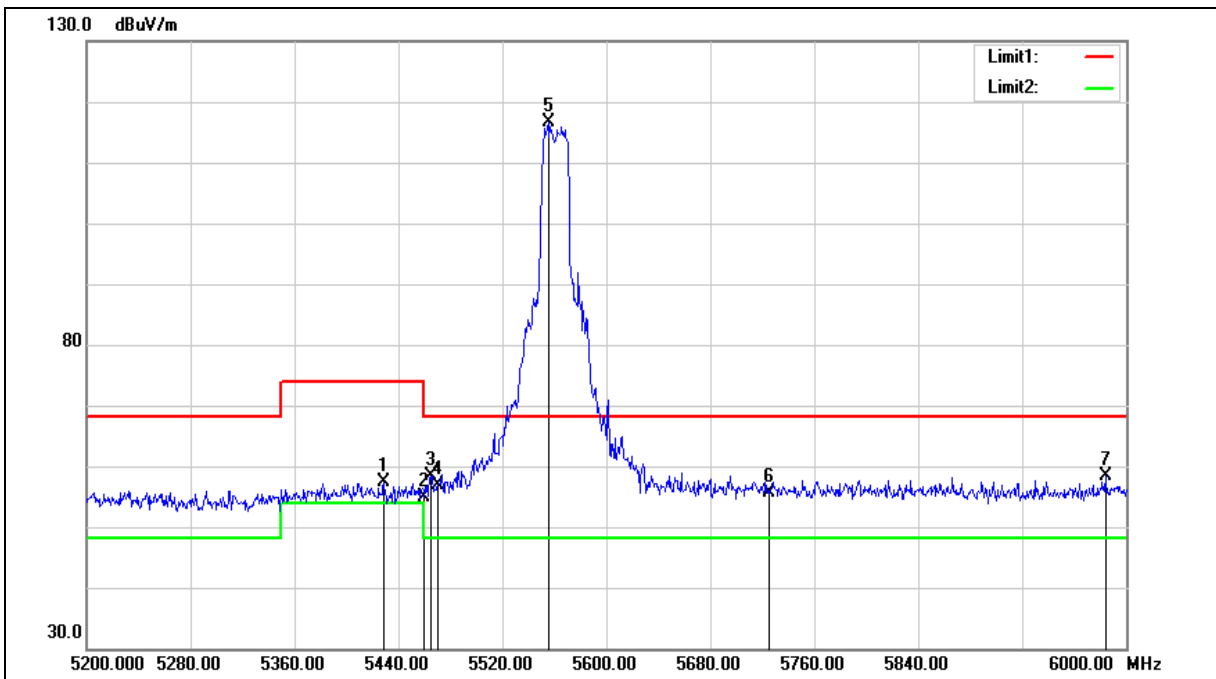

Standard:	FCC Part 15.407	Test Distance:	3 m
Test item:	Band edge		
Frequency:	5560 MHz		
Mode:	Mode 8		
Ant.Polar.:	Vertical		

No.	Frequency (MHz)	Reading (dBuV)	Correct Factor (dB/m)	Result (dBuV/m)	Limit (dBuV/m)	Margin (dB)	Remark
1	5428.800	51.24	6.10	57.34	74.00	-16.66	peak
2	5460.000	48.70	6.14	54.84	74.00	-19.16	peak
3	5464.800	52.34	6.14	58.48	68.20	-9.72	peak
4	5470.000	50.65	6.15	56.80	68.20	-11.40	peak
5	5555.200	110.34	6.33	116.67	68.20	48.47	peak
6	5725.000	48.99	6.76	55.75	68.20	-12.45	peak
7	5984.000	50.95	7.39	58.34	68.20	-9.86	peak

Note:1.Result (dBuV/m) = Correct Factor (dB/m) + Reading(dBuV).

2.Correction factor (dB/m) = Antenna Factor (dB/m) + Cable loss (dB) – Pre-Amplifier gain (dB).

3.When the peak results are less than average limit, so not need to evaluate the average.

Standard:	FCC Part 15.407	Test Distance:	3 m
Test item:	Band edge		
Frequency:	5700 MHz		
Mode:	Mode 8		
Ant.Polar.:	Horizontal		

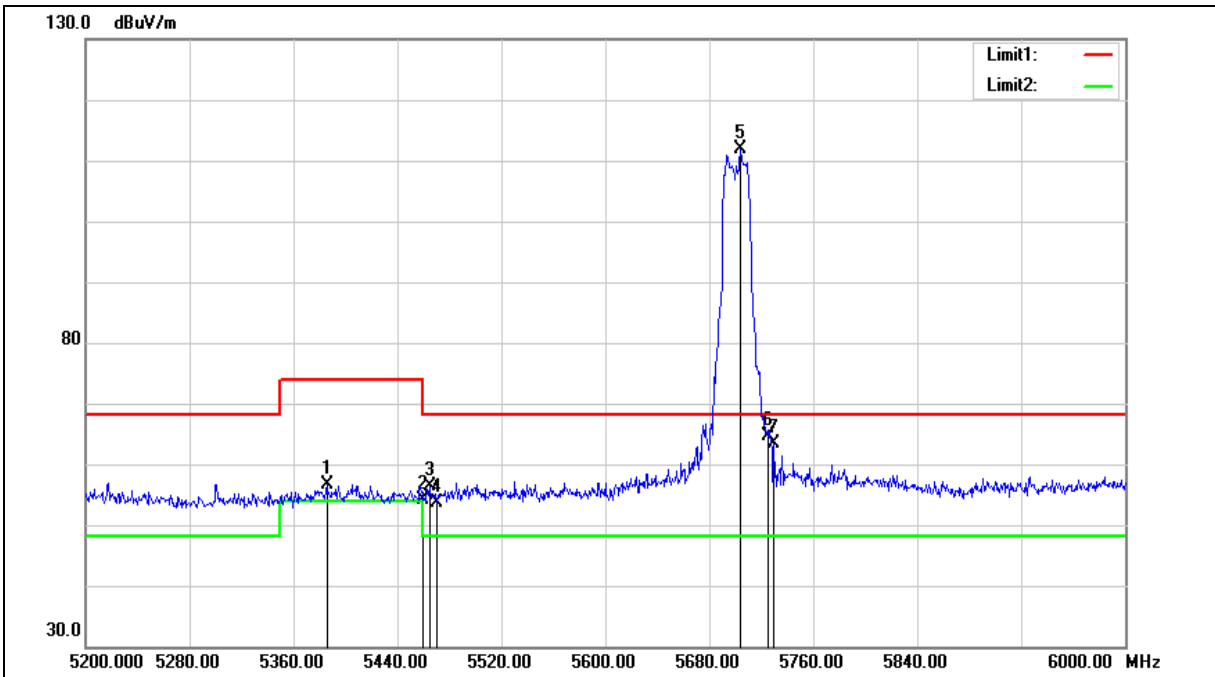

Standard:	FCC Part 15.407	Test Distance:	3 m
Test item:	Band edge		
Frequency:	5700 MHz		
Mode:	Mode 8		
Ant.Polar.:	Horizontal		

No.	Frequency (MHz)	Reading (dBuV)	Correct Factor (dB/m)	Result (dBuV/m)	Limit (dBuV/m)	Margin (dB)	Remark
1	5385.600	50.68	6.05	56.73	74.00	-17.27	peak
2	5460.000	48.00	6.14	54.14	74.00	-19.86	peak
3	5464.800	50.14	6.14	56.28	68.20	-11.92	peak
4	5470.000	47.36	6.15	53.51	68.20	-14.69	peak
5	5704.000	105.27	6.70	111.97	68.20	43.77	peak
6	5725.000	57.96	6.76	64.72	68.20	-3.48	peak
7	5729.600	56.58	6.76	63.34	68.20	-4.86	peak

Note:1.Result (dBuV/m) = Correct Factor (dB/m) + Reading(dBuV).

2.Correction factor (dB/m) = Antenna Factor (dB/m) + Cable loss (dB) – Pre-Amplifier gain (dB).

3.When the peak results are less than average limit, so not need to evaluate the average.

Standard:	FCC Part 15.407	Test Distance:	3 m
Test item:	Band edge		
Frequency:	5700 MHz		
Mode:	Mode 8		
Ant.Polar.:	Vertical		

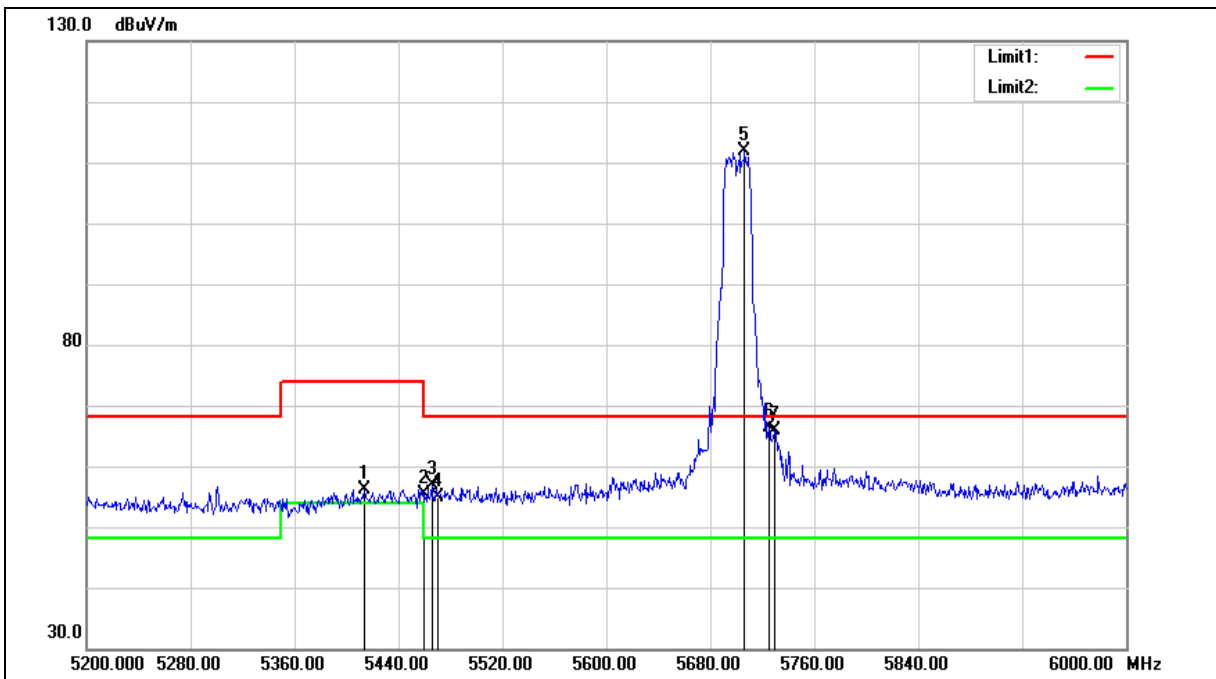

Standard:	FCC Part 15.407	Test Distance:	3 m
Test item:	Band edge		
Frequency:	5700 MHz		
Mode:	Mode 8		
Ant.Polar.:	Vertical		

No.	Frequency (MHz)	Reading (dBuV)	Correct Factor (dB/m)	Result (dBuV/m)	Limit (dBuV/m)	Margin (dB)	Remark
1	5413.600	50.11	6.08	56.19	74.00	-17.81	peak
2	5460.000	49.32	6.14	55.46	74.00	-18.54	peak
3	5465.600	50.82	6.14	56.96	68.20	-11.24	peak
4	5470.000	48.85	6.15	55.00	68.20	-13.20	peak
5	5706.400	105.25	6.70	111.95	68.20	43.75	peak
6	5725.000	59.64	6.76	66.40	68.20	-1.80	peak
7	5729.600	59.22	6.76	65.98	68.20	-2.22	peak

Note:1.Result (dBuV/m) = Correct Factor (dB/m) + Reading(dBuV).

2.Correction factor (dB/m) = Antenna Factor (dB/m) + Cable loss (dB) – Pre-Amplifier gain (dB).

3.When the peak results are less than average limit, so not need to evaluate the average.

Standard:	FCC Part 15.407	Test Distance:	3 m
Test item:	Band edge		
Frequency:	5720 MHz		
Mode:	Mode 8		
Ant.Polar.:	Horizontal		

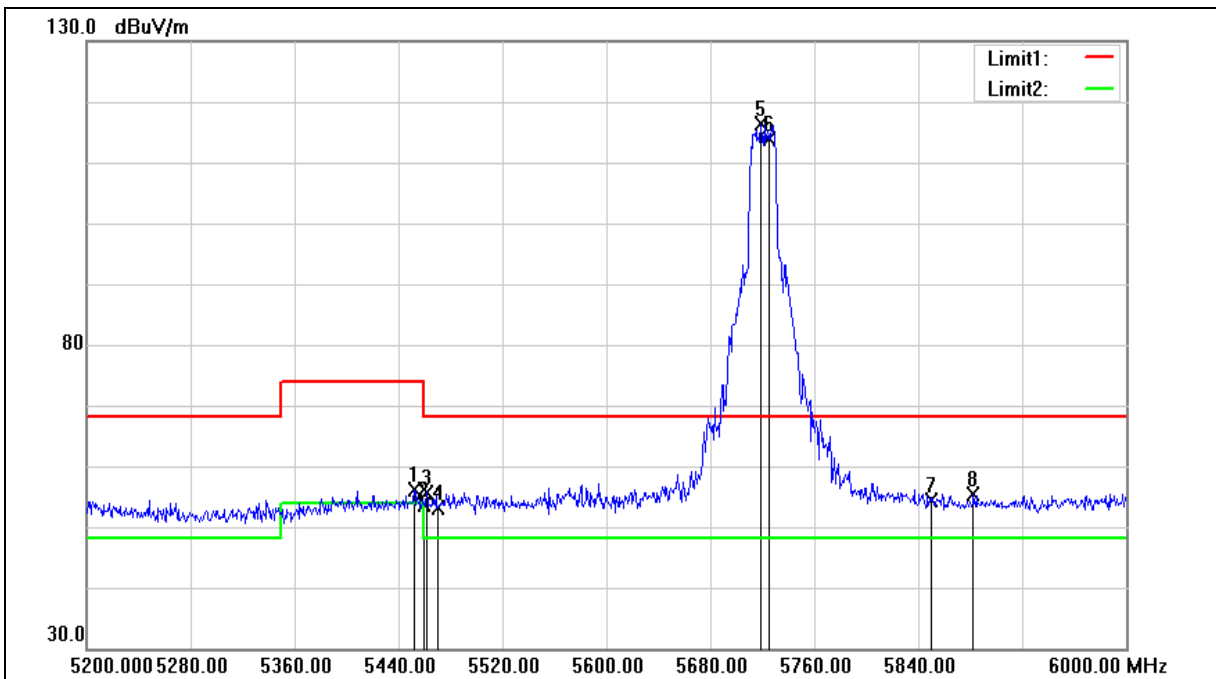

Standard:	FCC Part 15.407	Test Distance:	3 m
Test item:	Band edge		
Frequency:	5720 MHz		
Mode:	Mode 8		
Ant.Polar.:	Horizontal		

No.	Frequency (MHz)	Reading (dBuV)	Correct Factor (dB/m)	Result (dBuV/m)	Limit (dBuV/m)	Margin (dB)	Remark
1	5452.000	49.90	6.12	56.02	74.00	-17.98	peak
2	5460.000	47.53	6.14	53.67	74.00	-20.33	peak
3	5461.600	49.61	6.14	55.75	68.20	-12.45	peak
4	5470.000	47.01	6.15	53.16	68.20	-15.04	peak
5	5718.400	109.65	6.74	116.39	68.20	48.19	peak
6	5725.000	107.19	6.76	113.95	68.20	45.75	peak
7	5850.000	47.30	7.05	54.35	68.20	-13.85	peak
8	5882.400	48.14	7.14	55.28	68.20	-12.92	peak

Note:1.Result (dBuV/m) = Correct Factor (dB/m) + Reading(dBuV).

2.Correction factor (dB/m) = Antenna Factor (dB/m) + Cable loss (dB) – Pre-Amplifier gain (dB).

3.When the peak results are less than average limit, so not need to evaluate the average.

Standard:	FCC Part 15.407	Test Distance:	3 m
Test item:	Band edge		
Frequency:	5720 MHz		
Mode:	Mode 8		
Ant.Polar.:	Vertical		

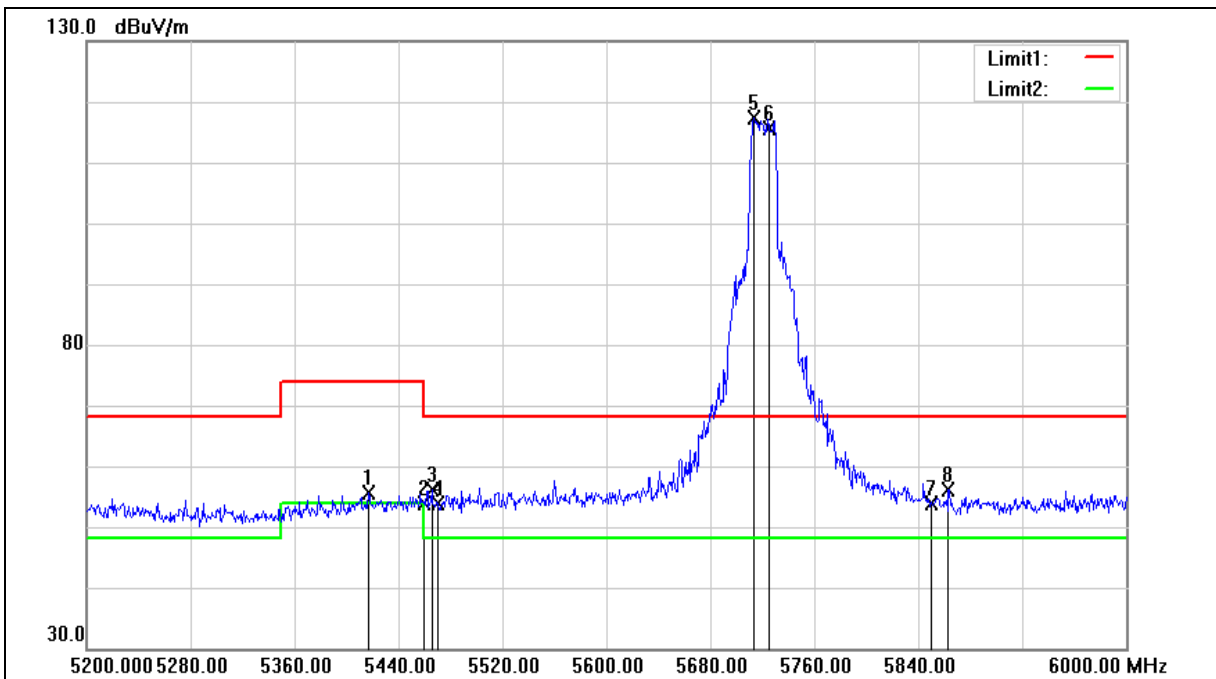

Standard:	FCC Part 15.407	Test Distance:	3 m
Test item:	Band edge		
Frequency:	5720 MHz		
Mode:	Mode 8		
Ant.Polar.:	Vertical		

No.	Frequency (MHz)	Reading (dBuV)	Correct Factor (dB/m)	Result (dBuV/m)	Limit (dBuV/m)	Margin (dB)	Remark
1	5416.800	49.46	6.09	55.55	74.00	-18.45	peak
2	5460.000	47.70	6.14	53.84	74.00	-20.16	peak
3	5465.600	49.97	6.14	56.11	68.20	-12.09	peak
4	5470.000	47.61	6.15	53.76	68.20	-14.44	peak
5	5713.600	110.61	6.72	117.33	68.20	49.13	peak
6	5725.000	108.97	6.76	115.73	68.20	47.53	peak
7	5850.000	46.79	7.05	53.84	68.20	-14.36	peak
8	5863.200	49.04	7.09	56.13	68.20	-12.07	peak

Note:1.Result (dBuV/m) = Correct Factor (dB/m) + Reading(dBuV).

2.Correction factor (dB/m) = Antenna Factor (dB/m) + Cable loss (dB) – Pre-Amplifier gain (dB).

3.When the peak results are less than average limit, so not need to evaluate the average.

Standard:	FCC Part 15.407	Test Distance:	3 m
Test item:	Band edge		
Frequency:	5190 MHz		
Mode:	Mode 9		
Ant.Polar.:	Horizontal		

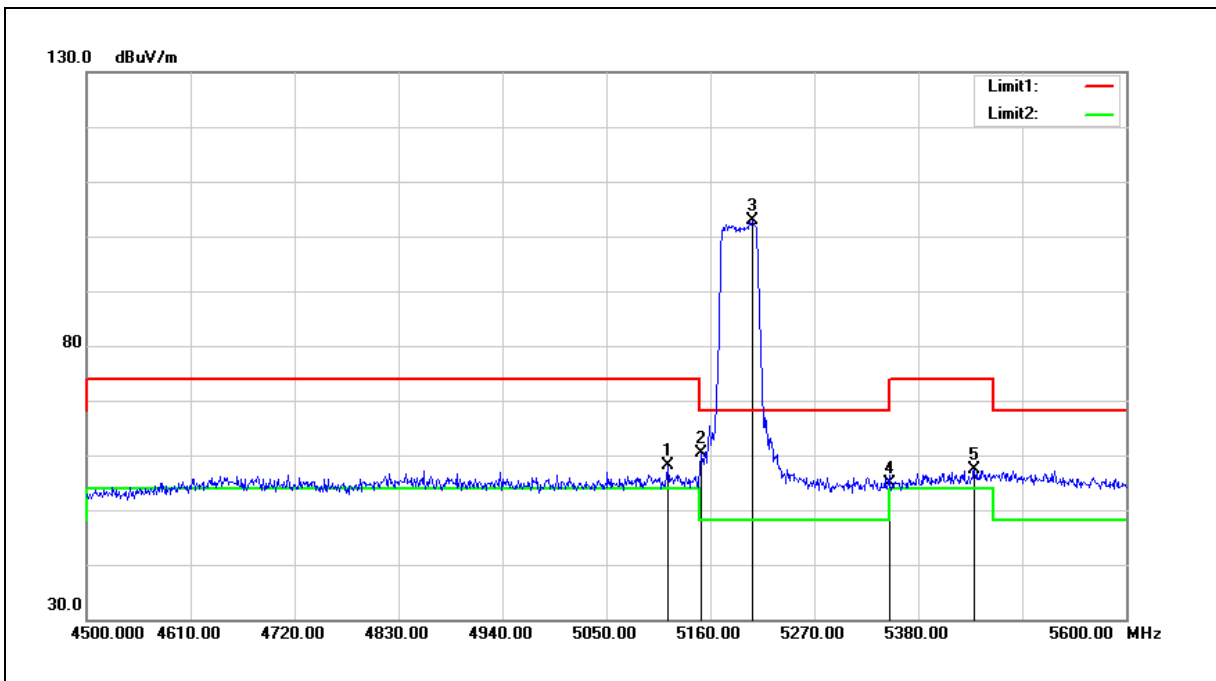

No.	Frequency (MHz)	Reading (dBuV)	Correct Factor (dB/m)	Result (dBuV/m)	Limit (dBuV/m)	Margin (dB)	Remark
1	5114.900	52.32	5.71	58.03	74.00	-15.97	peak
2	5150.000	54.73	5.75	60.48	74.00	-13.52	peak
3	5205.100	97.09	5.82	102.91	68.20	34.71	peak
4	5350.000	48.91	6.00	54.91	74.00	-19.09	peak
5	5439.400	51.16	6.12	57.28	74.00	-16.72	peak

Note:1.Result (dBuV/m) = Correct Factor (dB/m) + Reading(dBuV).

2.Correction factor (dB/m) = Antenna Factor (dB/m) + Cable loss (dB) – Pre-Amplifier gain (dB).

3.When the peak results are less than average limit, so not need to evaluate the average.

Standard:	FCC Part 15.407	Test Distance:	3 m
Test item:	Band edge		
Frequency:	5190 MHz		
Mode:	Mode 9		
Ant.Polar.:	Vertical		

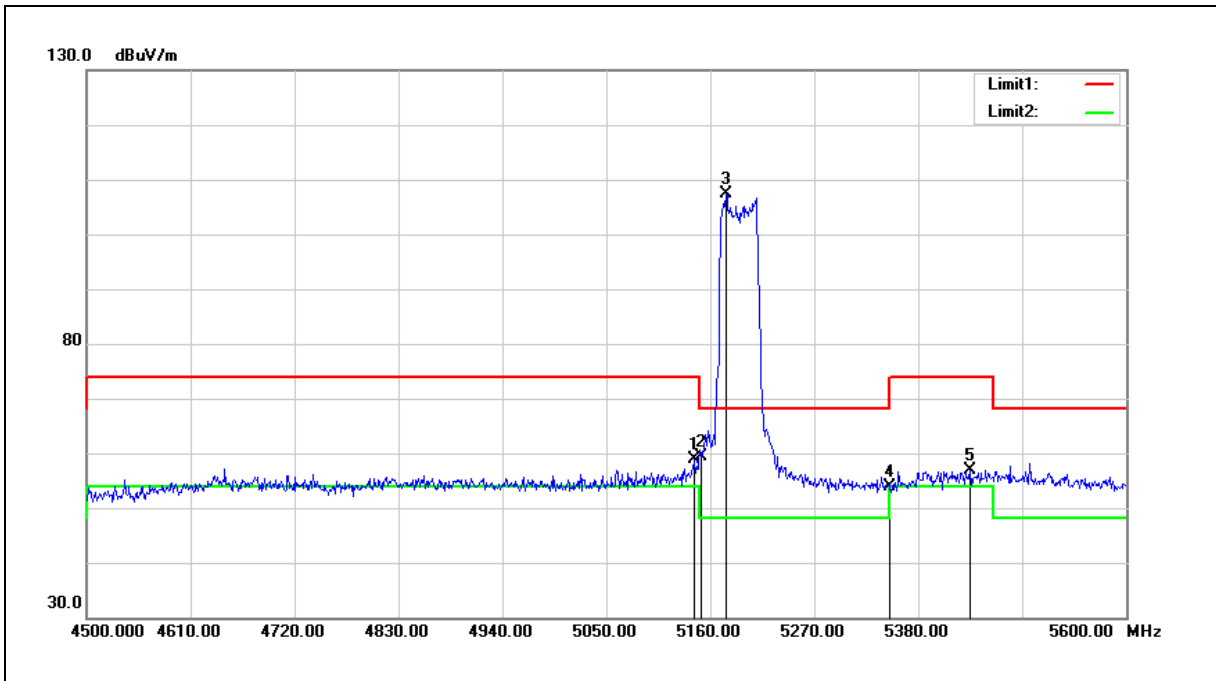

No.	Frequency (MHz)	Reading (dBuV)	Correct Factor (dB/m)	Result (dBuV/m)	Limit (dBuV/m)	Margin (dB)	Remark
1	5143.500	53.23	5.75	58.98	74.00	-15.02	peak
2	5150.000	53.54	5.75	59.29	74.00	-14.71	peak
3	5176.500	101.50	5.79	107.29	68.20	39.09	peak
4	5350.000	47.85	6.00	53.85	74.00	-20.15	peak
5	5435.000	50.85	6.11	56.96	74.00	-17.04	peak

Note:1.Result (dBuV/m) = Correct Factor (dB/m) + Reading(dBuV).

2.Correction factor (dB/m) = Antenna Factor (dB/m) + Cable loss (dB) – Pre-Amplifier gain (dB).

3.When the peak results are less than average limit, so not need to evaluate the average.

Standard:	FCC Part 15.407	Test Distance:	3 m
Test item:	Band edge		
Frequency:	5230 MHz		
Mode:	Mode 9		
Ant.Polar.:	Horizontal		

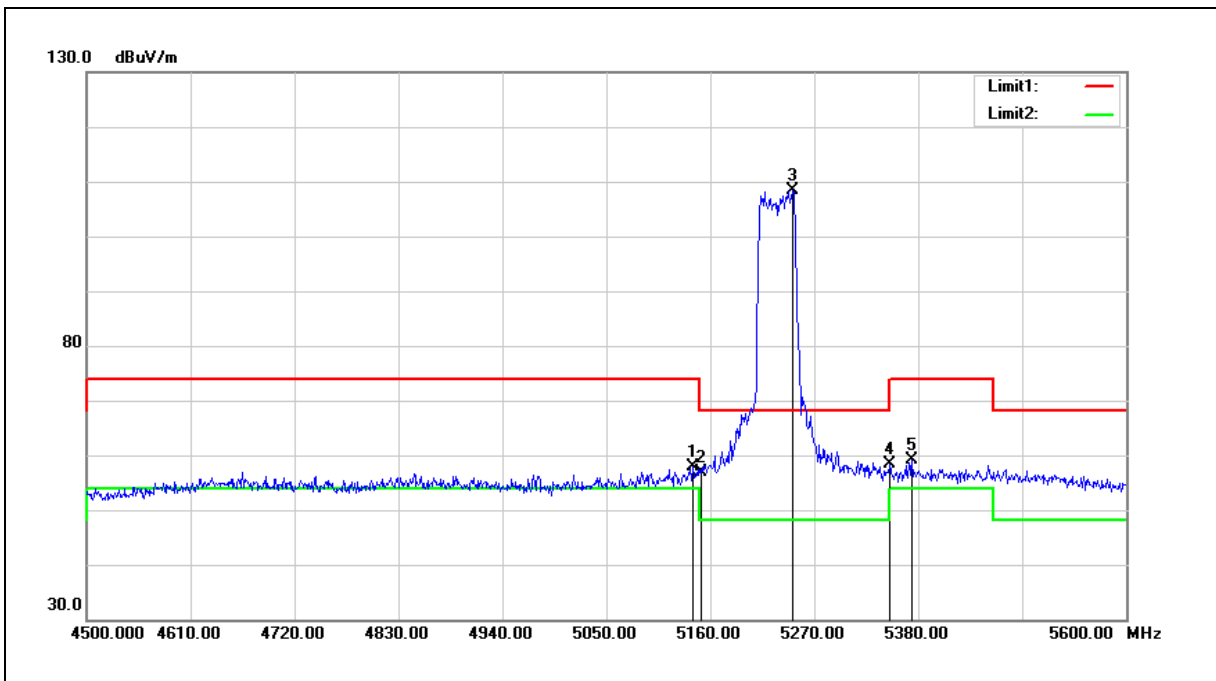

No.	Frequency (MHz)	Reading (dBuV)	Correct Factor (dB/m)	Result (dBuV/m)	Limit (dBuV/m)	Margin (dB)	Remark
1	5141.300	52.11	5.75	57.86	74.00	-16.14	peak
2	5150.000	51.14	5.75	56.89	74.00	-17.11	peak
3	5246.900	102.46	5.88	108.34	68.20	40.14	peak
4	5350.000	52.39	6.00	58.39	74.00	-15.61	peak
5	5373.400	53.11	6.03	59.14	74.00	-14.86	peak

Note:1.Result (dBuV/m) = Correct Factor (dB/m) + Reading(dBuV).

2.Correction factor (dB/m) = Antenna Factor (dB/m) + Cable loss (dB) – Pre-Amplifier gain (dB).

3.When the peak results are less than average limit, so not need to evaluate the average.

Standard:	FCC Part 15.407	Test Distance:	3 m
Test item:	Band edge		
Frequency:	5230 MHz		
Mode:	Mode 9		
Ant.Polar.:	Vertical		

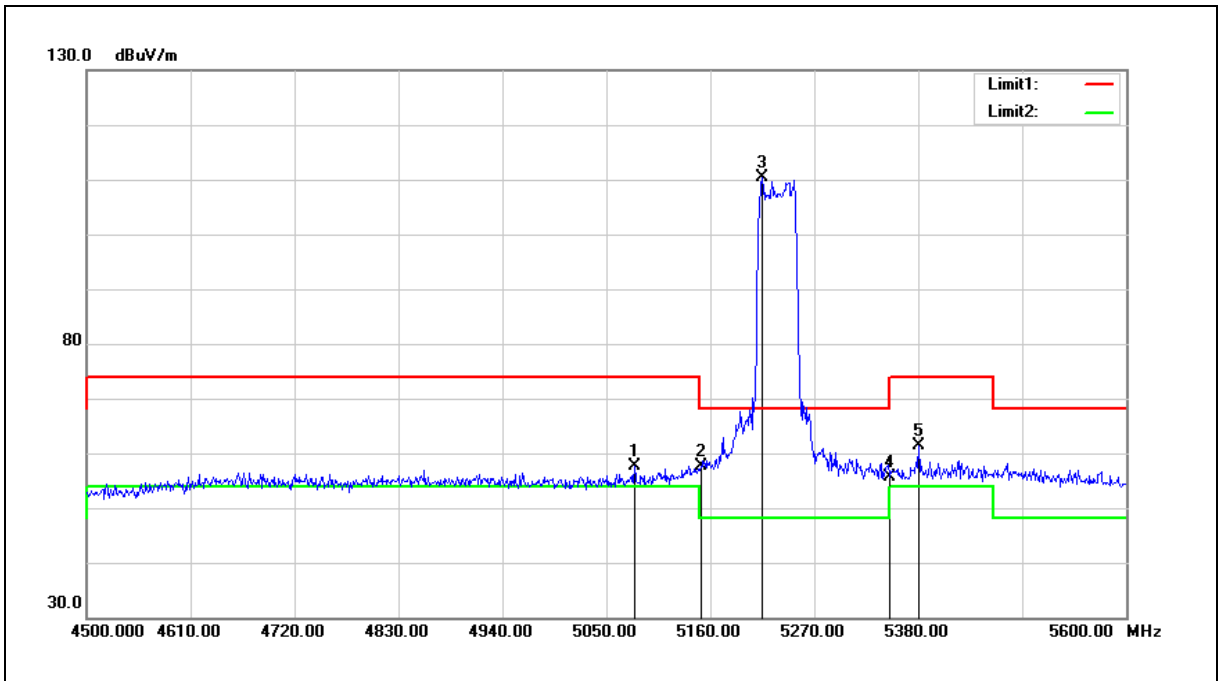

No.	Frequency (MHz)	Reading (dBuV)	Correct Factor (dB/m)	Result (dBuV/m)	Limit (dBuV/m)	Margin (dB)	Remark
1	5079.700	51.97	5.66	57.63	74.00	-16.37	peak
2	5150.000	51.77	5.75	57.52	74.00	-16.48	peak
3	5215.000	104.53	5.84	110.37	68.20	42.17	peak
4	5350.000	49.53	6.00	55.53	74.00	-18.47	peak
5	5381.100	55.44	6.04	61.48	74.00	-12.52	peak

Note:1.Result (dBuV/m) = Correct Factor (dB/m) + Reading(dBuV).

2.Correction factor (dB/m) = Antenna Factor (dB/m) + Cable loss (dB) – Pre-Amplifier gain (dB).

3.When the peak results are less than average limit, so not need to evaluate the average.

Standard:	FCC Part 15.407	Test Distance:	3 m
Test item:	Band edge		
Frequency:	5270 MHz		
Mode:	Mode 9		
Ant.Polar.:	Horizontal		

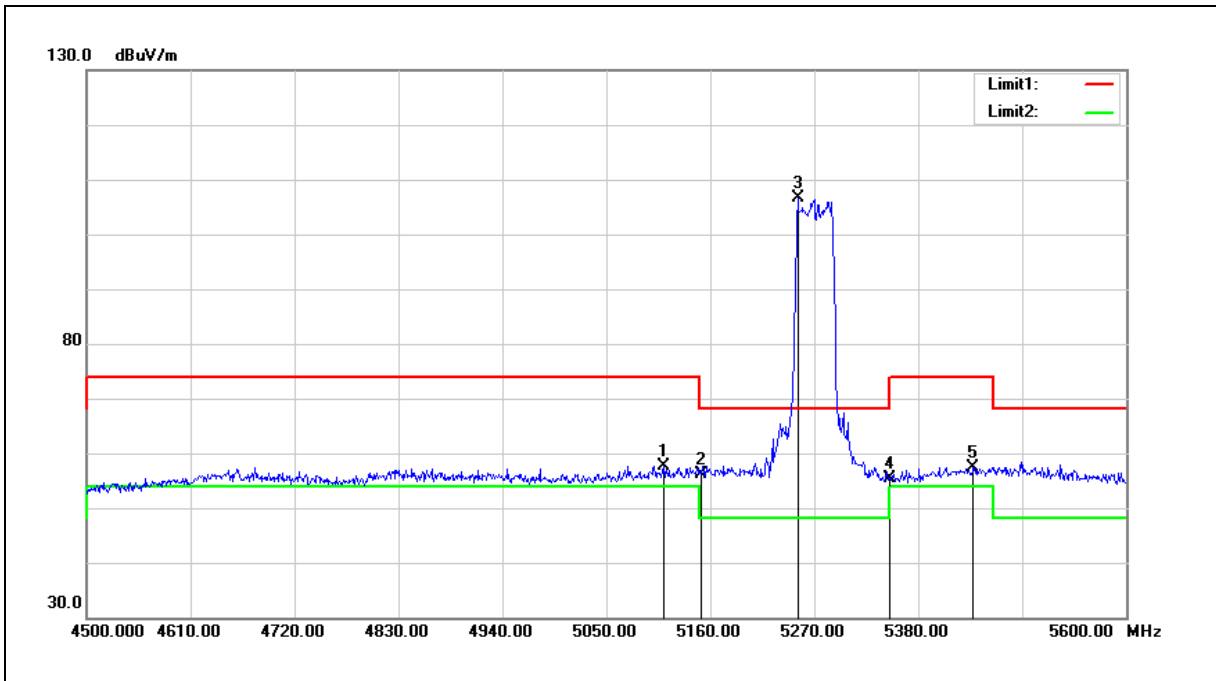

No.	Frequency (MHz)	Reading (dBuV)	Correct Factor (dB/m)	Result (dBuV/m)	Limit (dBuV/m)	Margin (dB)	Remark
1	5110.500	51.91	5.71	57.62	74.00	-16.38	peak
2	5150.000	50.38	5.75	56.13	74.00	-17.87	peak
3	5252.400	100.63	5.88	106.51	68.20	38.31	peak
4	5350.000	49.30	6.00	55.30	74.00	-18.70	peak
5	5438.300	51.35	6.12	57.47	74.00	-16.53	peak

Note:1.Result (dBuV/m) = Correct Factor (dB/m) + Reading(dBuV).

2.Correction factor (dB/m) = Antenna Factor (dB/m) + Cable loss (dB) – Pre-Amplifier gain (dB).

3.When the peak results are less than average limit, so not need to evaluate the average.

Standard:	FCC Part 15.407	Test Distance:	3 m
Test item:	Band edge		
Frequency:	5270 MHz		
Mode:	Mode 9		
Ant.Polar.:	Vertical		

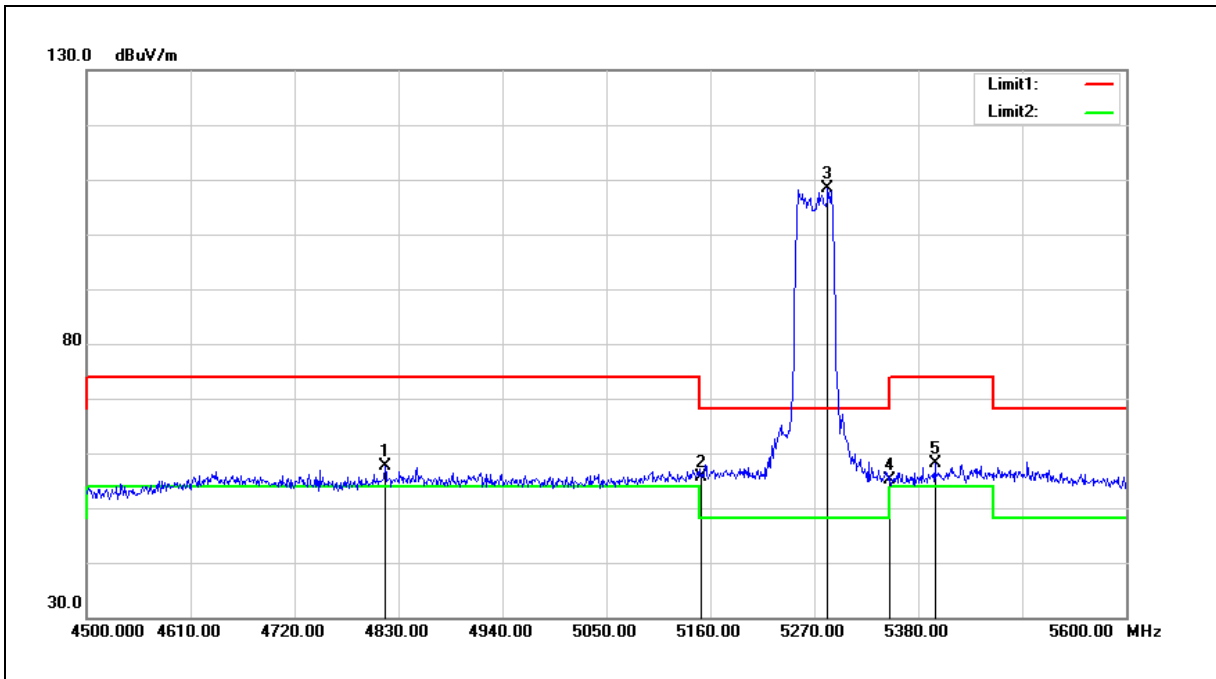

No.	Frequency (MHz)	Reading (dBuV)	Correct Factor (dB/m)	Result (dBuV/m)	Limit (dBuV/m)	Margin (dB)	Remark
1	4815.700	52.63	5.07	57.70	74.00	-16.30	peak
2	5150.000	49.78	5.75	55.53	74.00	-18.47	peak
3	5284.300	102.51	5.92	108.43	68.20	40.23	peak
4	5350.000	49.03	6.00	55.03	74.00	-18.97	peak
5	5397.600	52.06	6.06	58.12	74.00	-15.88	peak

Note:1.Result (dBuV/m) = Correct Factor (dB/m) + Reading(dBuV).

2.Correction factor (dB/m) = Antenna Factor (dB/m) + Cable loss (dB) – Pre-Amplifier gain (dB).

3.When the peak results are less than average limit, so not need to evaluate the average.

Standard:	FCC Part 15.407	Test Distance:	3 m
Test item:	Band edge		
Frequency:	5310 MHz		
Mode:	Mode 9		
Ant.Polar.:	Horizontal		

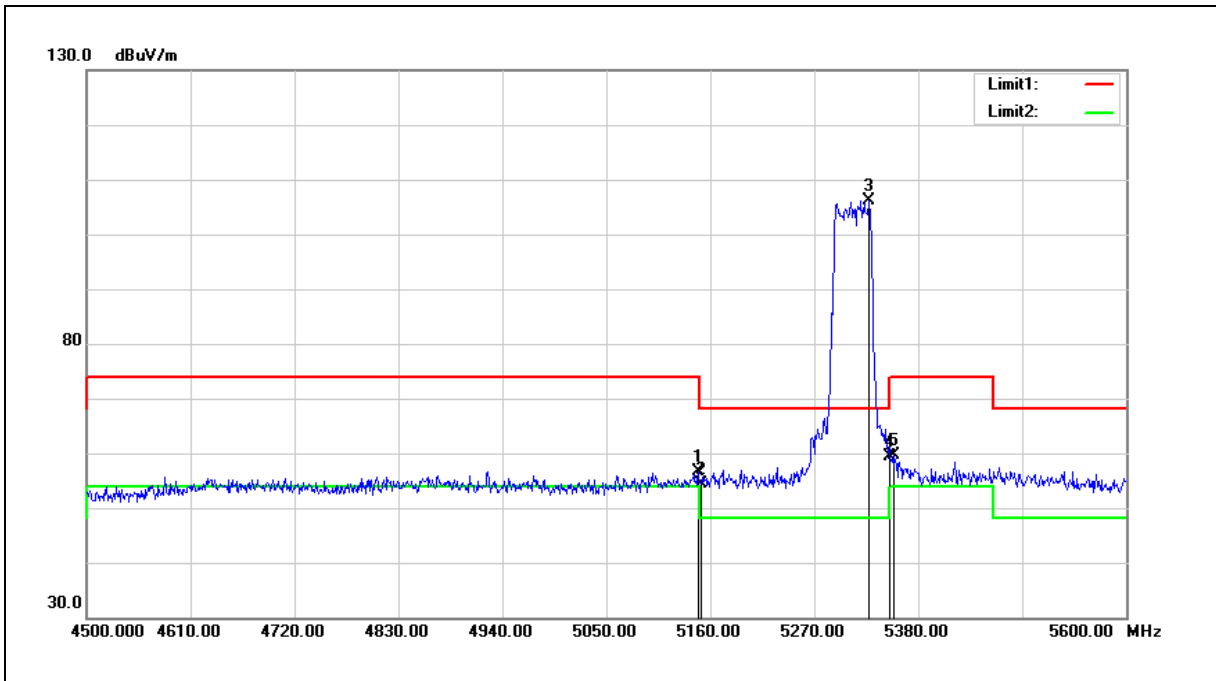

No.	Frequency (MHz)	Reading (dBuV)	Correct Factor (dB/m)	Result (dBuV/m)	Limit (dBuV/m)	Margin (dB)	Remark
1	5146.800	50.85	5.76	56.61	74.00	-17.39	peak
2	5150.000	48.64	5.75	54.39	74.00	-19.61	peak
3	5328.300	100.16	5.98	106.14	68.20	37.94	peak
4	5350.000	53.38	6.00	59.38	74.00	-14.62	peak
5	5354.700	53.58	6.00	59.58	74.00	-14.42	peak

Note:1.Result (dBuV/m) = Correct Factor (dB/m) + Reading(dBuV).

2.Correction factor (dB/m) = Antenna Factor (dB/m) + Cable loss (dB) – Pre-Amplifier gain (dB).

3.When the peak results are less than average limit, so not need to evaluate the average.

Standard:	FCC Part 15.407	Test Distance:	3 m
Test item:	Band edge		
Frequency:	5310 MHz		
Mode:	Mode 9		
Ant.Polar.:	Vertical		

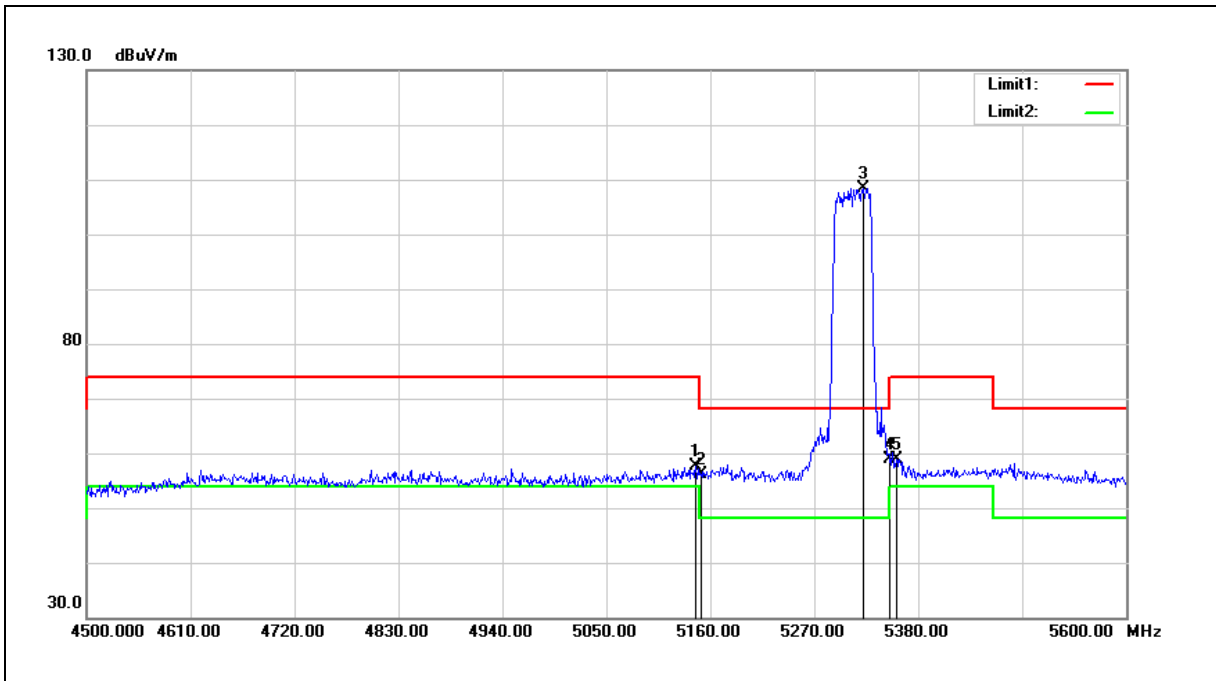

No.	Frequency (MHz)	Reading (dBuV)	Correct Factor (dB/m)	Result (dBuV/m)	Limit (dBuV/m)	Margin (dB)	Remark
1	5144.600	51.89	5.76	57.65	74.00	-16.35	peak
2	5150.000	50.27	5.75	56.02	74.00	-17.98	peak
3	5321.700	102.52	5.97	108.49	68.20	40.29	peak
4	5350.000	52.95	6.00	58.95	74.00	-15.05	peak
5	5356.900	52.97	6.01	58.98	74.00	-15.02	peak

Note:1.Result (dBuV/m) = Correct Factor (dB/m) + Reading(dBuV).

2.Correction factor (dB/m) = Antenna Factor (dB/m) + Cable loss (dB) – Pre-Amplifier gain (dB).

3.When the peak results are less than average limit, so not need to evaluate the average.

Standard:	FCC Part 15.407	Test Distance:	3 m
Test item:	Band edge		
Frequency:	5510 MHz		
Mode:	Mode 9		
Ant.Polar.:	Horizontal		

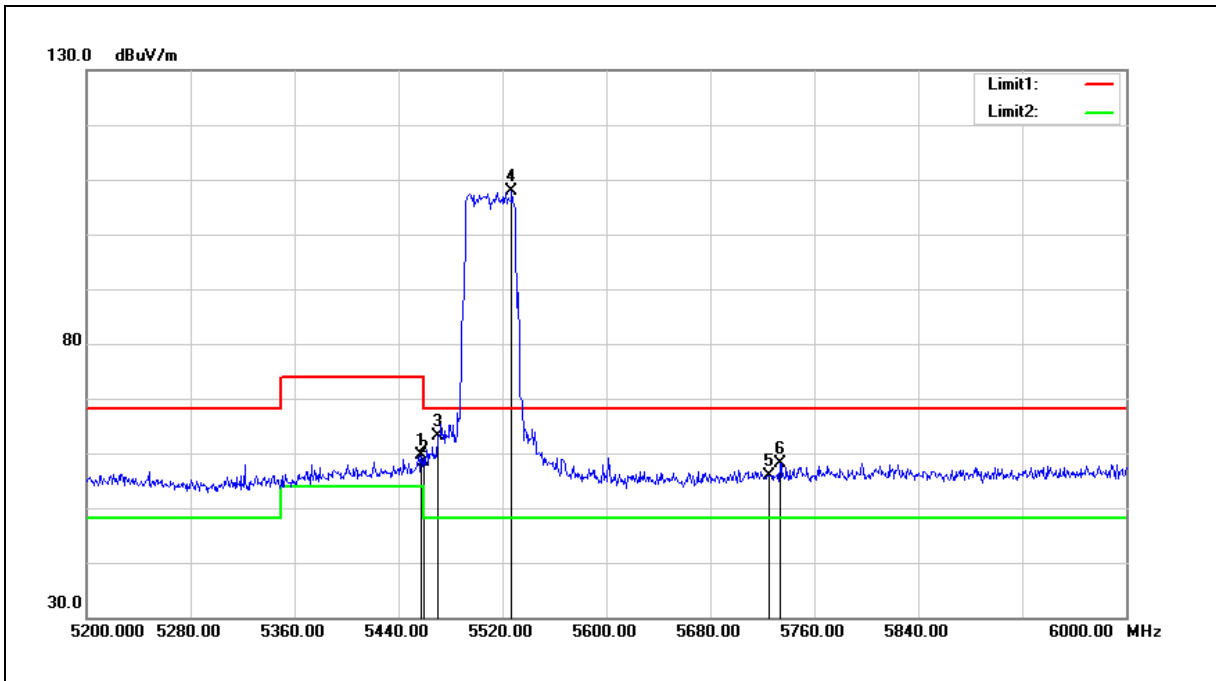

No.	Frequency (MHz)	Reading (dBuV)	Correct Factor (dB/m)	Result (dBuV/m)	Limit (dBuV/m)	Margin (dB)	Remark
1	5457.600	53.44	6.14	59.58	74.00	-14.42	peak
2	5460.000	52.17	6.14	58.31	74.00	-15.69	peak
3	5470.000	56.88	6.15	63.03	68.20	-5.17	peak
4	5527.200	101.72	6.26	107.98	68.20	39.78	peak
5	5725.000	49.01	6.76	55.77	68.20	-12.43	peak
6	5733.600	51.46	6.78	58.24	68.20	-9.96	peak

Note:1.Result (dBuV/m) = Correct Factor (dB/m) + Reading(dBuV).

2.Correction factor (dB/m) = Antenna Factor (dB/m) + Cable loss (dB) – Pre-Amplifier gain (dB).

3.When the peak results are less than average limit, so not need to evaluate the average.

Standard:	FCC Part 15.407	Test Distance:	3 m
Test item:	Band edge		
Frequency:	5510 MHz		
Mode:	Mode 9		
Ant.Polar.:	Vertical		

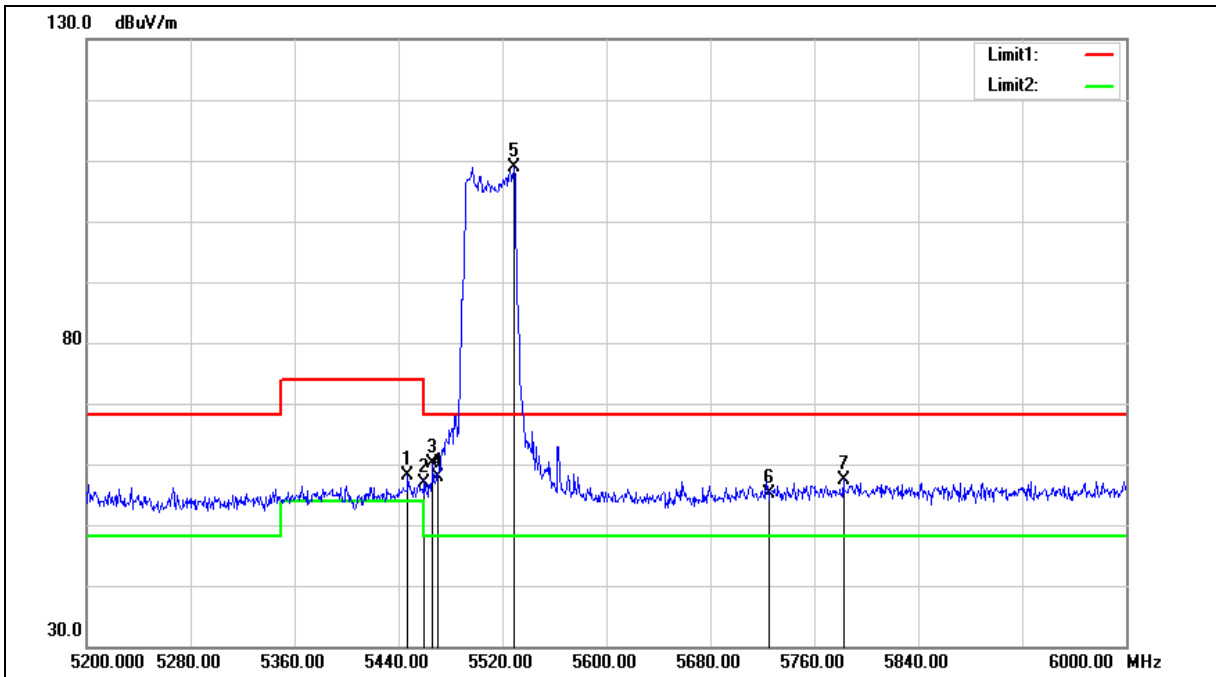

Standard:	FCC Part 15.407	Test Distance:	3 m
Test item:	Band edge		
Frequency:	5510 MHz		
Mode:	Mode 9		
Ant.Polar.:	Vertical		

No.	Frequency (MHz)	Reading (dBuV)	Correct Factor (dB/m)	Result (dBuV/m)	Limit (dBuV/m)	Margin (dB)	Remark
1	5447.200	51.96	6.13	58.09	74.00	-15.91	peak
2	5460.000	50.86	6.14	57.00	74.00	-17.00	peak
3	5466.400	53.88	6.14	60.02	68.20	-8.18	peak
4	5470.000	51.74	6.15	57.89	68.20	-10.31	peak
5	5528.800	102.73	6.26	108.99	68.20	40.79	peak
6	5725.000	48.43	6.76	55.19	68.20	-13.01	peak
7	5782.400	50.61	6.89	57.50	68.20	-10.70	peak

Note:1.Result (dBuV/m) = Correct Factor (dB/m) + Reading(dBuV).

2.Correction factor (dB/m) = Antenna Factor (dB/m) + Cable loss (dB) – Pre-Amplifier gain (dB).

3.When the peak results are less than average limit, so not need to evaluate the average.

Standard:	FCC Part 15.407	Test Distance:	3 m
Test item:	Band edge		
Frequency:	5550 MHz		
Mode:	Mode 9		
Ant.Polar.:	Horizontal		

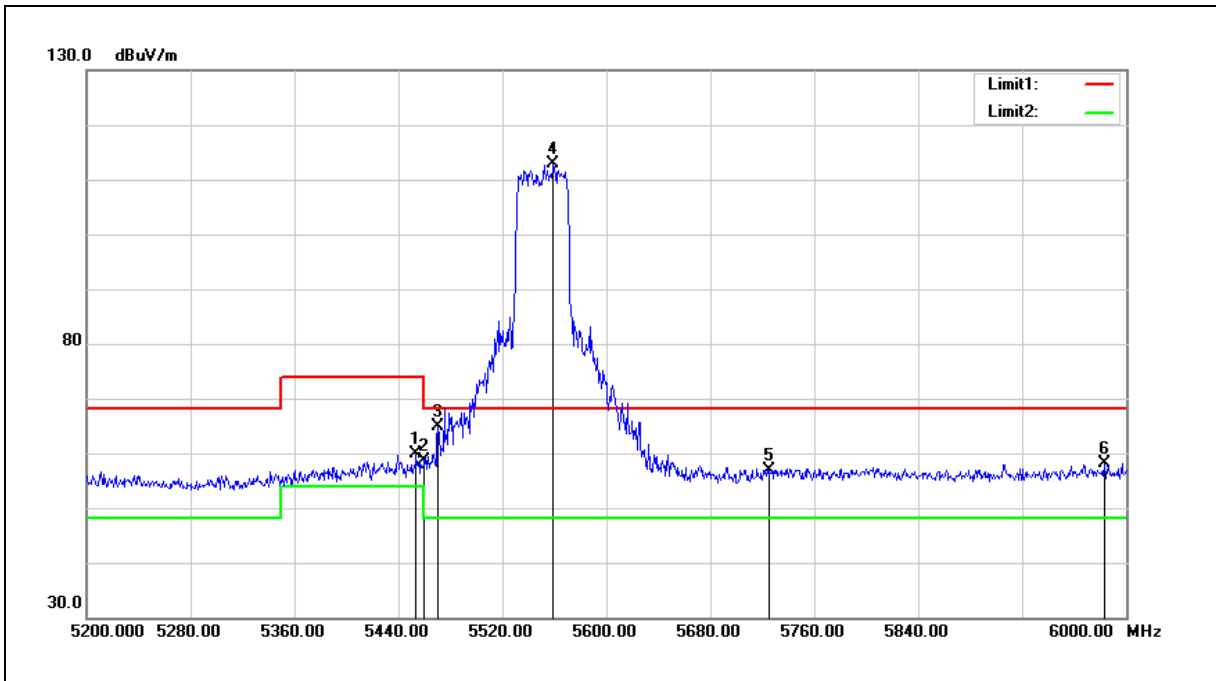

No.	Frequency (MHz)	Reading (dBuV)	Correct Factor (dB/m)	Result (dBuV/m)	Limit (dBuV/m)	Margin (dB)	Remark
1	5453.600	53.88	6.12	60.00	74.00	-14.00	peak
2	5460.000	52.42	6.14	58.56	74.00	-15.44	peak
3	5470.000	58.61	6.15	64.76	68.20	-3.44	peak
4	5559.200	106.45	6.33	112.78	68.20	44.58	peak
5	5725.000	50.23	6.76	56.99	68.20	-11.21	peak
6	5983.200	50.76	7.39	58.15	68.20	-10.05	peak

Note:1.Result (dBuV/m) = Correct Factor (dB/m) + Reading(dBuV).

2.Correction factor (dB/m) = Antenna Factor (dB/m) + Cable loss (dB) – Pre-Amplifier gain (dB).

3.When the peak results are less than average limit, so not need to evaluate the average.

Standard:	FCC Part 15.407	Test Distance:	3 m
Test item:	Band edge		
Frequency:	5550 MHz		
Mode:	Mode 9		
Ant.Polar.:	Vertical		

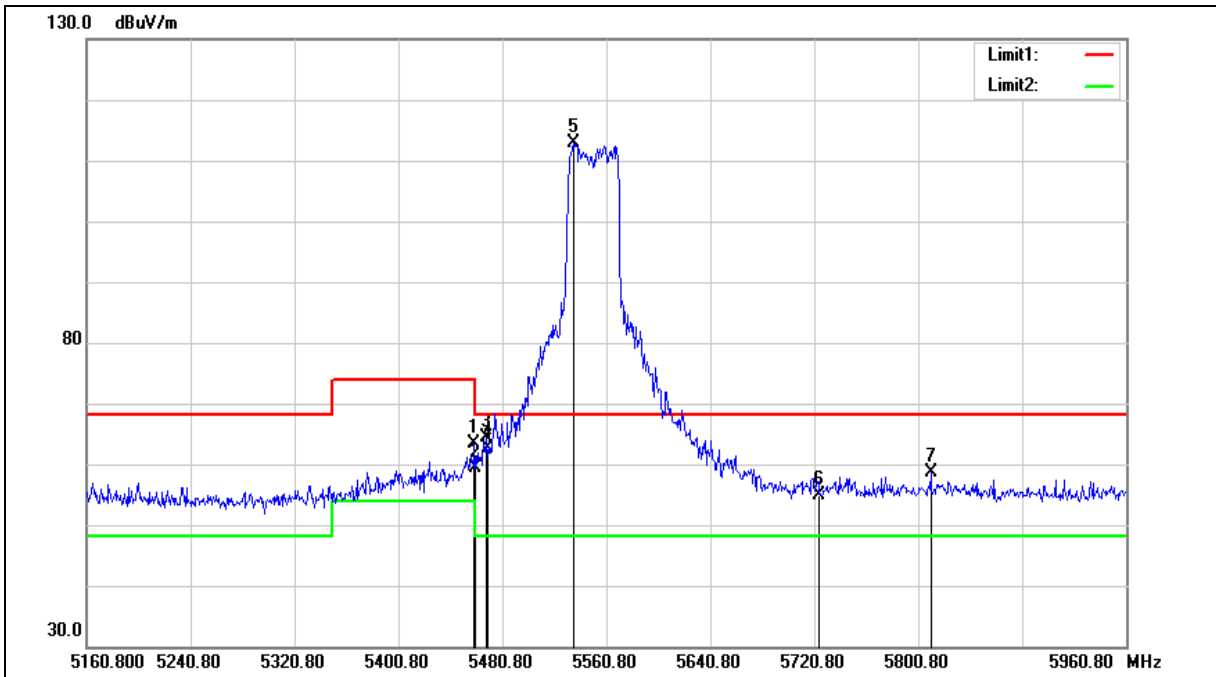

Standard:	FCC Part 15.407	Test Distance:	3 m
Test item:	Band edge		
Frequency:	5550 MHz		
Mode:	Mode 9		
Ant.Polar.:	Vertical		

No.	Frequency (MHz)	Reading (dBuV)	Correct Factor (dB/m)	Result (dBuV/m)	Limit (dBuV/m)	Margin (dB)	Remark
1	5459.200	57.32	6.14	63.46	74.00	-10.54	peak
2	5460.000	53.13	6.14	59.27	74.00	-14.73	peak
3	5468.800	58.17	6.15	64.32	68.20	-3.88	peak
4	5470.000	56.38	6.15	62.53	68.20	-5.67	peak
5	5535.200	106.52	6.28	112.80	68.20	44.60	peak
6	5725.000	48.20	6.76	54.96	68.20	-13.24	peak
7	5810.400	51.62	6.96	58.58	68.20	-9.62	peak

Note:1.Result (dBuV/m) = Correct Factor (dB/m) + Reading(dBuV).

2.Correction factor (dB/m) = Antenna Factor (dB/m) + Cable loss (dB) – Pre-Amplifier gain (dB).

3.When the peak results are less than average limit, so not need to evaluate the average.

Standard:	FCC Part 15.407	Test Distance:	3 m
Test item:	Band edge		
Frequency:	5670 MHz		
Mode:	Mode 9		
Ant.Polar.:	Horizontal		

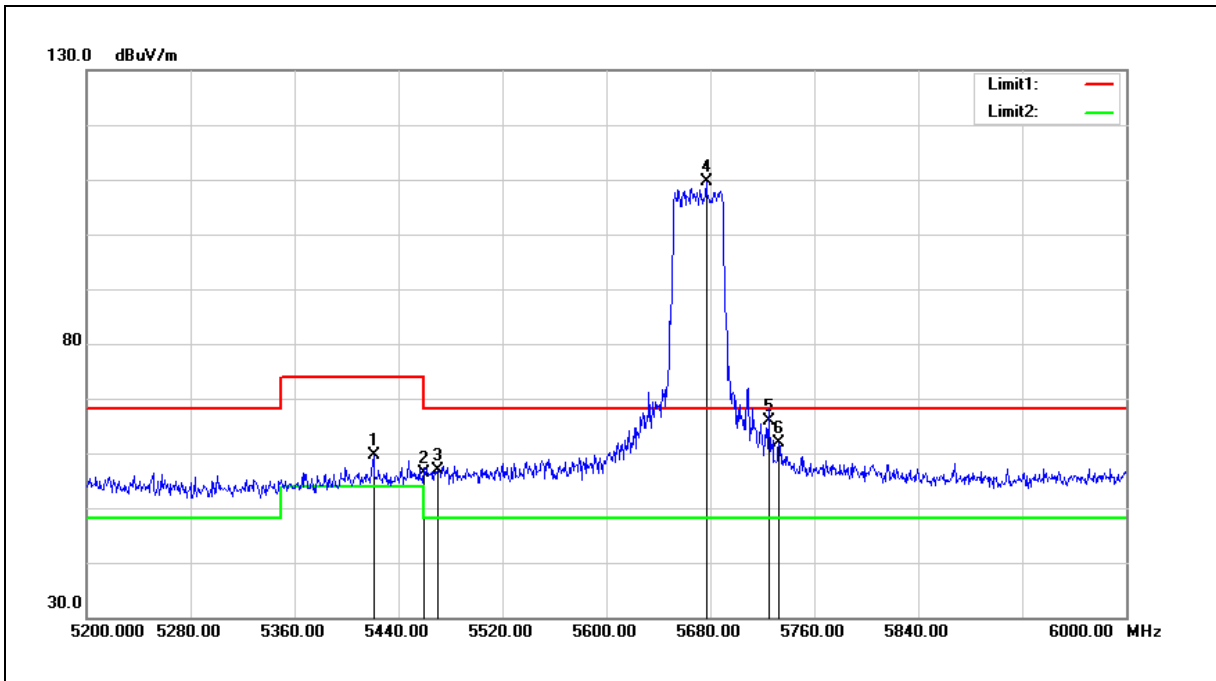

No.	Frequency (MHz)	Reading (dBuV)	Correct Factor (dB/m)	Result (dBuV/m)	Limit (dBuV/m)	Margin (dB)	Remark
1	5420.800	53.47	6.10	59.57	74.00	-14.43	peak
2	5460.000	50.30	6.14	56.44	74.00	-17.56	peak
3	5470.000	50.75	6.15	56.90	68.20	-11.30	peak
4	5676.800	103.11	6.63	109.74	68.20	41.54	peak
5	5725.000	59.19	6.76	65.95	68.20	-2.25	peak
6	5732.800	55.23	6.77	62.00	68.20	-6.20	peak

Note:1.Result (dBuV/m) = Correct Factor (dB/m) + Reading(dBuV).

2.Correction factor (dB/m) = Antenna Factor (dB/m) + Cable loss (dB) – Pre-Amplifier gain (dB).

3.When the peak results are less than average limit, so not need to evaluate the average.

Standard:	FCC Part 15.407	Test Distance:	3 m
Test item:	Band edge		
Frequency:	5670 MHz		
Mode:	Mode 9		
Ant.Polar.:	Vertical		

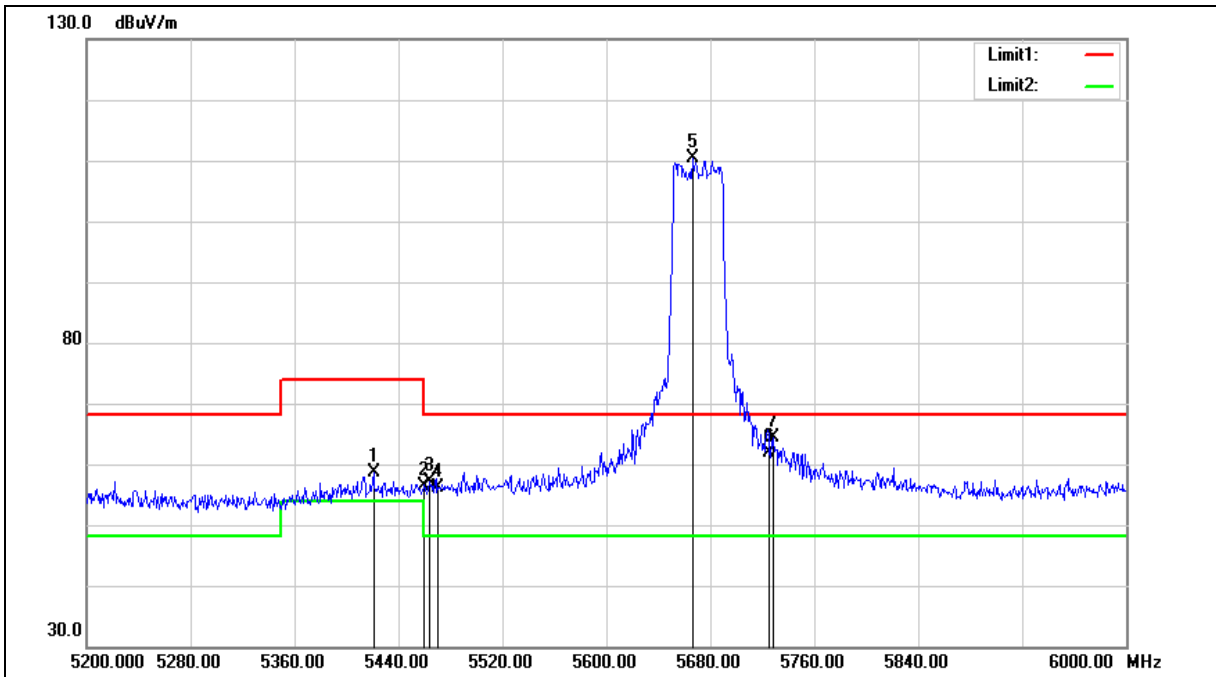

Standard:	FCC Part 15.407	Test Distance:	3 m
Test item:	Band edge		
Frequency:	5670 MHz		
Mode:	Mode 9		
Ant.Polar.:	Vertical		

No.	Frequency (MHz)	Reading (dBuV)	Correct Factor (dB/m)	Result (dBuV/m)	Limit (dBuV/m)	Margin (dB)	Remark
1	5420.800	52.42	6.10	58.52	74.00	-15.48	peak
2	5460.000	50.36	6.14	56.50	74.00	-17.50	peak
3	5464.000	51.04	6.14	57.18	68.20	-11.02	peak
4	5470.000	50.09	6.15	56.24	68.20	-11.96	peak
5	5666.400	103.76	6.60	110.36	68.20	42.16	peak
6	5725.000	55.14	6.76	61.90	68.20	-6.30	peak
7	5728.000	57.51	6.76	64.27	68.20	-3.93	peak

Note:1.Result (dBuV/m) = Correct Factor (dB/m) + Reading(dBuV).

2.Correction factor (dB/m) = Antenna Factor (dB/m) + Cable loss (dB) – Pre-Amplifier gain (dB).

3.When the peak results are less than average limit, so not need to evaluate the average.

Standard:	FCC Part 15.407	Test Distance:	3 m
Test item:	Band edge		
Frequency:	5710 MHz		
Mode:	Mode 9		
Ant.Polar.:	Horizontal		

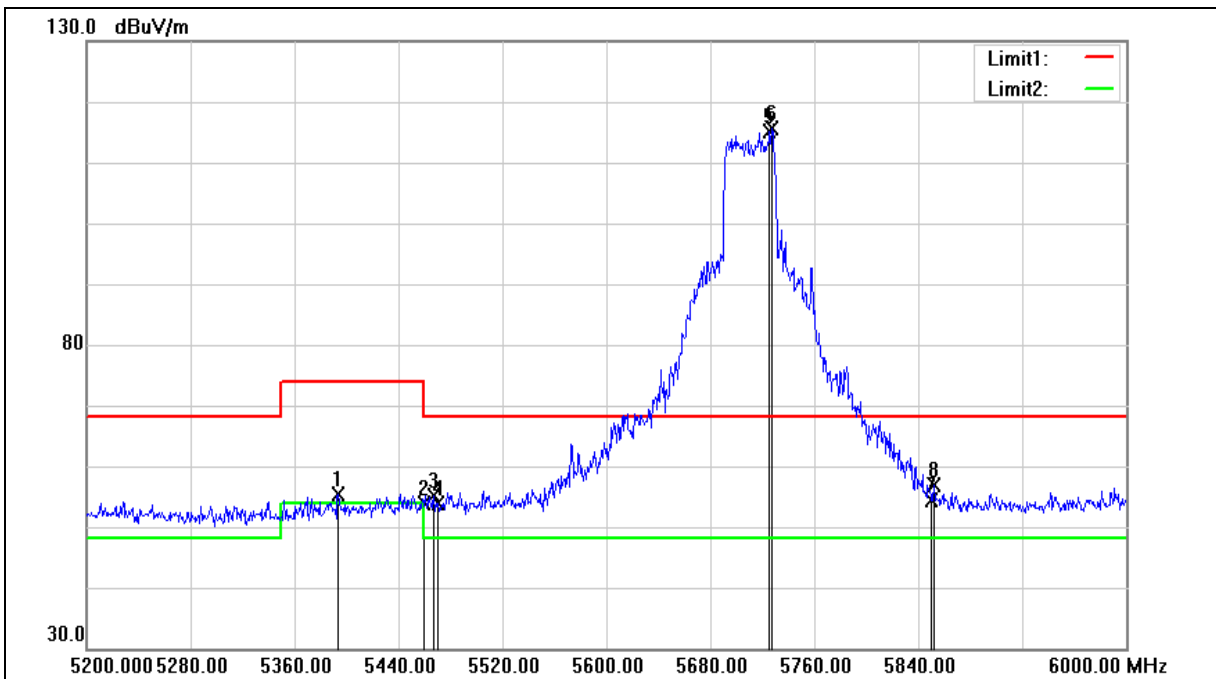

Standard:	FCC Part 15.407	Test Distance:	3 m
Test item:	Band edge		
Frequency:	5710 MHz		
Mode:	Mode 9		
Ant.Polar.:	Horizontal		

No.	Frequency (MHz)	Reading (dBuV)	Correct Factor (dB/m)	Result (dBuV/m)	Limit (dBuV/m)	Margin (dB)	Remark
1	5393.600	49.42	6.05	55.47	74.00	-18.53	peak
2	5460.000	47.74	6.14	53.88	74.00	-20.12	peak
3	5467.200	48.92	6.14	55.06	68.20	-13.14	peak
4	5470.000	47.80	6.15	53.95	68.20	-14.25	peak
5	5725.000	108.25	6.76	115.01	68.20	46.81	peak
6	5727.200	108.91	6.76	115.67	68.20	47.47	peak
7	5850.000	47.36	7.05	54.41	68.20	-13.79	peak
8	5852.000	49.71	7.06	56.77	68.20	-11.43	peak

Note:1.Result (dBuV/m) = Correct Factor (dB/m) + Reading(dBuV).

2.Correction factor (dB/m) = Antenna Factor (dB/m) + Cable loss (dB) – Pre-Amplifier gain (dB).

3.When the peak results are less than average limit, so not need to evaluate the average.

Standard:	FCC Part 15.407	Test Distance:	3 m
Test item:	Band edge		
Frequency:	5710 MHz		
Mode:	Mode 9		
Ant.Polar.:	Vertical		

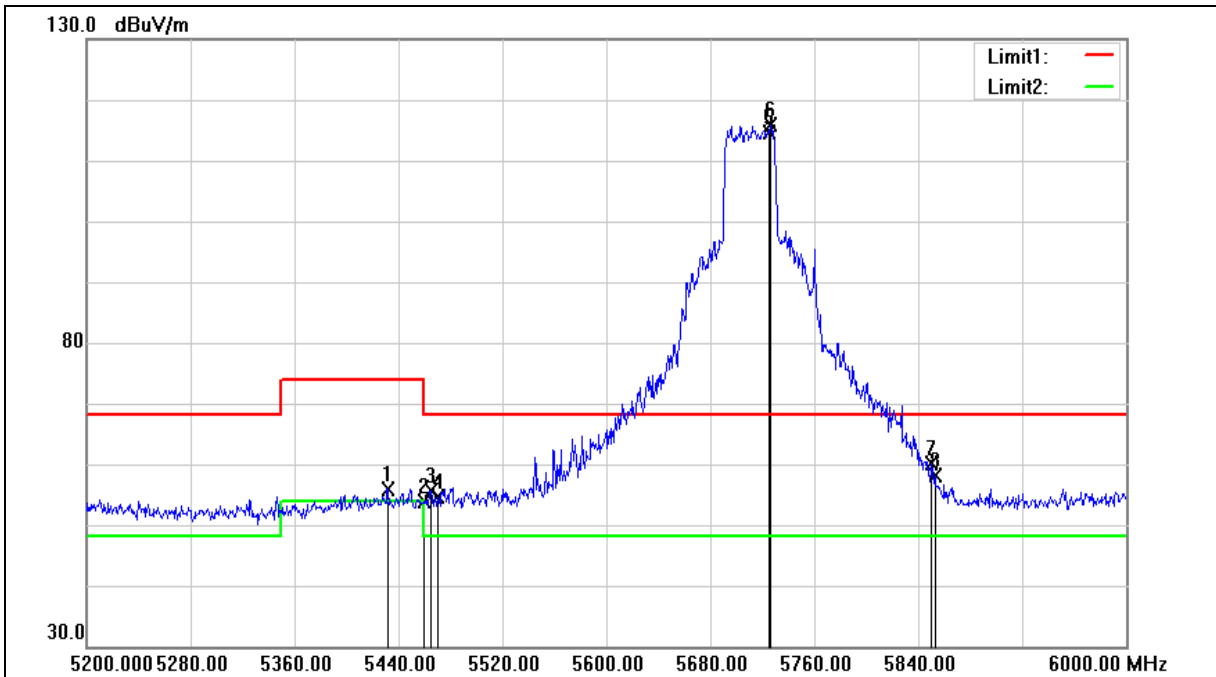

Standard:	FCC Part 15.407	Test Distance:	3 m
Test item:	Band edge		
Frequency:	5710 MHz		
Mode:	Mode 9		
Ant.Polar.:	Vertical		

No.	Frequency (MHz)	Reading (dBuV)	Correct Factor (dB/m)	Result (dBuV/m)	Limit (dBuV/m)	Margin (dB)	Remark
1	5432.000	49.88	6.11	55.99	74.00	-18.01	peak
2	5460.000	47.77	6.14	53.91	74.00	-20.09	peak
3	5464.800	49.50	6.14	55.64	68.20	-12.56	peak
4	5470.000	48.51	6.15	54.66	68.20	-13.54	peak
5	5725.000	107.96	6.76	114.72	68.20	46.52	peak
6	5726.400	109.10	6.76	115.86	68.20	47.66	peak
7	5850.000	53.09	7.05	60.14	68.20	-8.06	peak
8	5852.800	50.97	7.06	58.03	68.20	-10.17	peak

Note:1.Result (dBuV/m) = Correct Factor (dB/m) + Reading(dBuV).

2.Correction factor (dB/m) = Antenna Factor (dB/m) + Cable loss (dB) – Pre-Amplifier gain (dB).

3.When the peak results are less than average limit, so not need to evaluate the average.

Standard:	FCC Part 15.407	Test Distance:	3 m
Test item:	Band edge		
Frequency:	5210 MHz		
Mode:	Mode 10		
Ant.Polar.:	Horizontal		

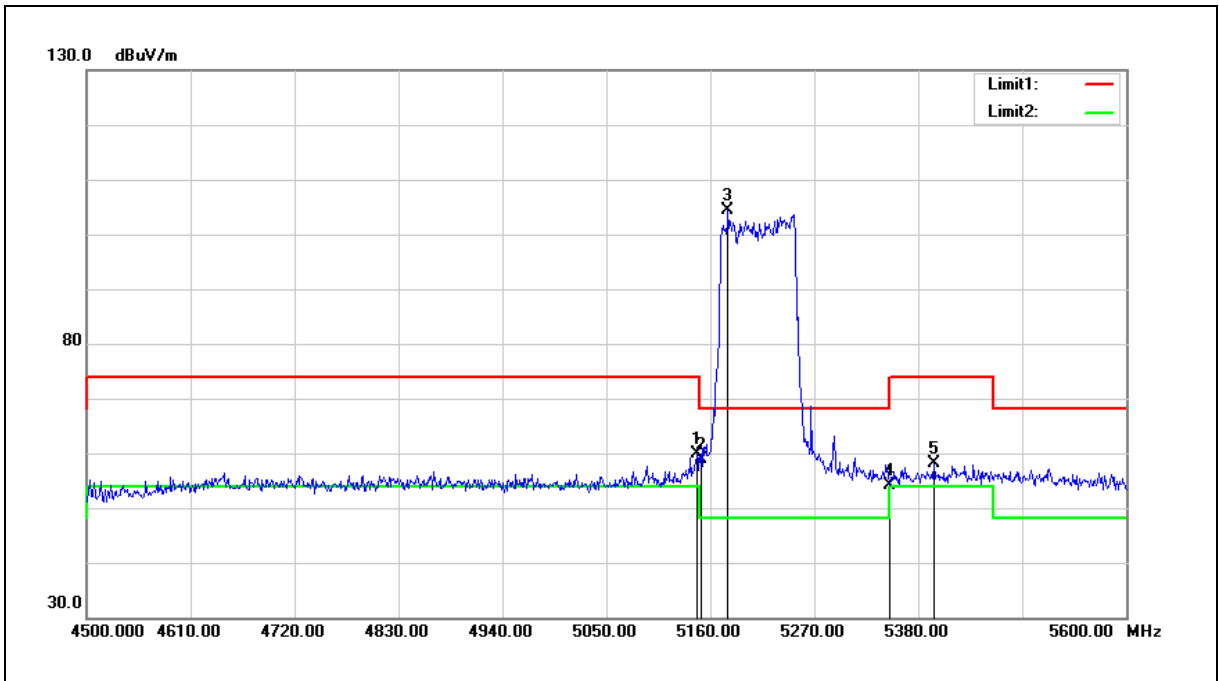

No.	Frequency (MHz)	Reading (dBuV)	Correct Factor (dB/m)	Result (dBuV/m)	Limit (dBuV/m)	Margin (dB)	Remark
1	5145.700	54.22	5.76	59.98	74.00	-14.02	peak
2	5150.000	53.11	5.75	58.86	74.00	-15.14	peak
3	5178.700	98.64	5.79	104.43	68.20	36.23	peak
4	5350.000	48.21	6.00	54.21	74.00	-19.79	peak
5	5396.500	52.06	6.06	58.12	74.00	-15.88	peak

Note:1.Result (dBuV/m) = Correct Factor (dB/m) + Reading(dBuV).

2.Correction factor (dB/m) = Antenna Factor (dB/m) + Cable loss (dB) – Pre-Amplifier gain (dB).

3.When the peak results are less than average limit, so not need to evaluate the average.

Standard:	FCC Part 15.407	Test Distance:	3 m
Test item:	Band edge		
Frequency:	5210 MHz		
Mode:	Mode 10		
Ant.Polar.:	Vertical		

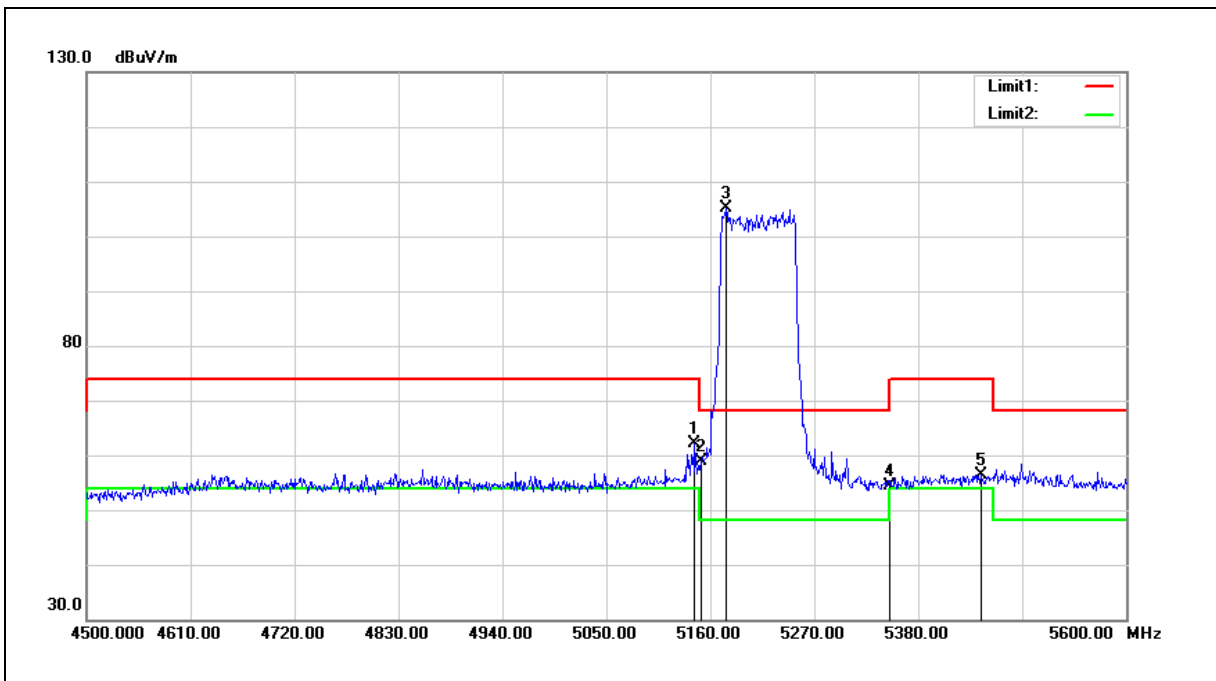

No.	Frequency (MHz)	Reading (dBuV)	Correct Factor (dB/m)	Result (dBuV/m)	Limit (dBuV/m)	Margin (dB)	Remark
1	5143.500	56.35	5.75	62.10	74.00	-11.90	peak
2	5150.000	53.22	5.75	58.97	74.00	-15.03	peak
3	5176.500	99.34	5.79	105.13	68.20	36.93	peak
4	5350.000	48.27	6.00	54.27	74.00	-19.73	peak
5	5446.000	50.30	6.13	56.43	74.00	-17.57	peak

Note:1.Result (dBuV/m) = Correct Factor (dB/m) + Reading(dBuV).

2.Correction factor (dB/m) = Antenna Factor (dB/m) + Cable loss (dB) – Pre-Amplifier gain (dB).

3.When the peak results are less than average limit, so not need to evaluate the average.

Standard:	FCC Part 15.407	Test Distance:	3 m
Test item:	Band edge		
Frequency:	5290 MHz		
Mode:	Mode 10		
Ant.Polar.:	Horizontal		

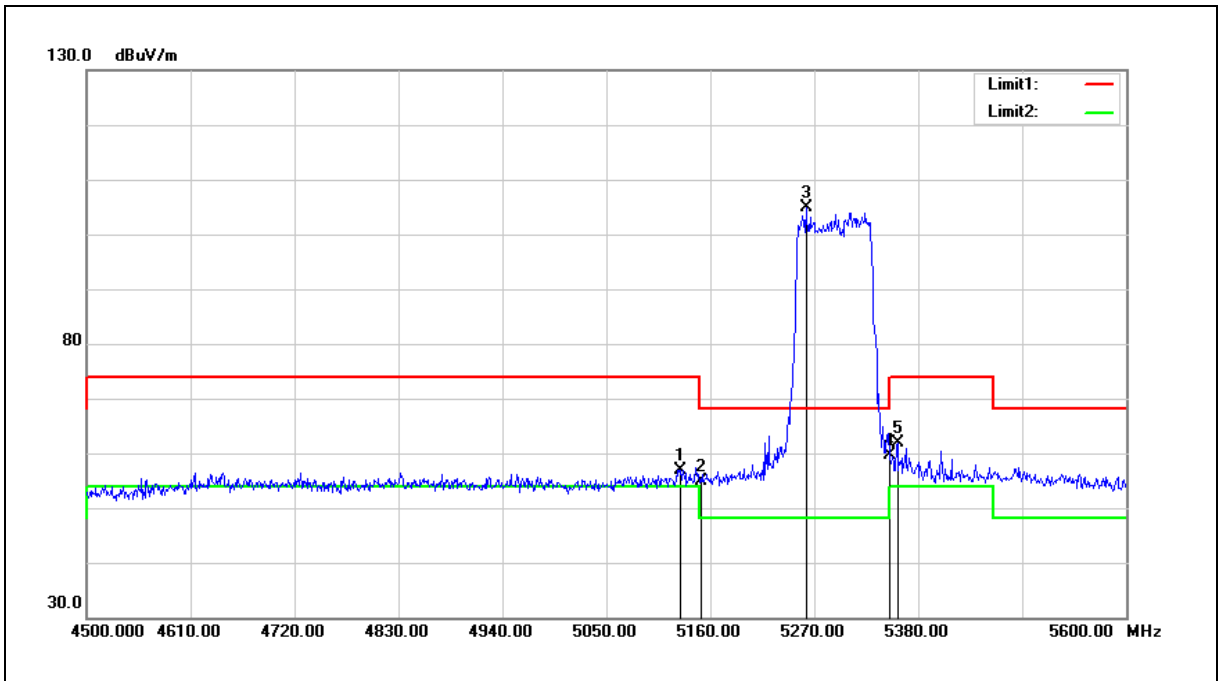

No.	Frequency (MHz)	Reading (dBuV)	Correct Factor (dB/m)	Result (dBuV/m)	Limit (dBuV/m)	Margin (dB)	Remark
1	5128.100	51.18	5.73	56.91	74.00	-17.09	peak
2	5150.000	49.10	5.75	54.85	74.00	-19.15	peak
3	5261.200	99.01	5.89	104.90	68.20	36.70	peak
4	5350.000	53.63	6.00	59.63	74.00	-14.37	peak
5	5358.000	55.81	6.01	61.82	74.00	-12.18	peak

Note:1.Result (dBuV/m) = Correct Factor (dB/m) + Reading(dBuV).

2.Correction factor (dB/m) = Antenna Factor (dB/m) + Cable loss (dB) – Pre-Amplifier gain (dB).

3.When the peak results are less than average limit, so not need to evaluate the average.

Standard:	FCC Part 15.407	Test Distance:	3 m
Test item:	Band edge		
Frequency:	5290 MHz		
Mode:	Mode 10		
Ant.Polar.:	Vertical		

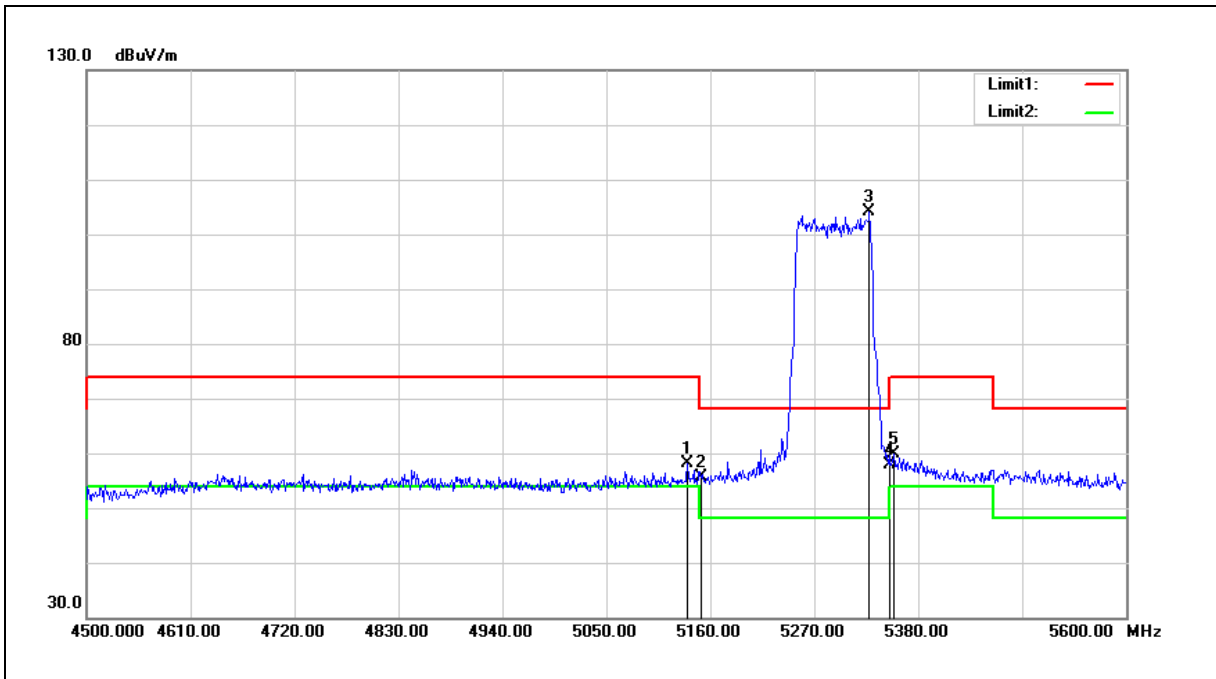

No.	Frequency (MHz)	Reading (dBuV)	Correct Factor (dB/m)	Result (dBuV/m)	Limit (dBuV/m)	Margin (dB)	Remark
1	5135.800	52.44	5.74	58.18	74.00	-15.82	peak
2	5150.000	49.95	5.75	55.70	74.00	-18.30	peak
3	5328.300	98.20	5.98	104.18	68.20	35.98	peak
4	5350.000	51.81	6.00	57.81	74.00	-16.19	peak
5	5354.700	53.97	6.00	59.97	74.00	-14.03	peak

Note:1.Result (dBuV/m) = Correct Factor (dB/m) + Reading(dBuV).

2.Correction factor (dB/m) = Antenna Factor (dB/m) + Cable loss (dB) – Pre-Amplifier gain (dB).

3.When the peak results are less than average limit, so not need to evaluate the average.

Standard:	FCC Part 15.407	Test Distance:	3 m
Test item:	Band edge		
Frequency:	5530 MHz		
Mode:	Mode 10		
Ant.Polar.:	Horizontal		

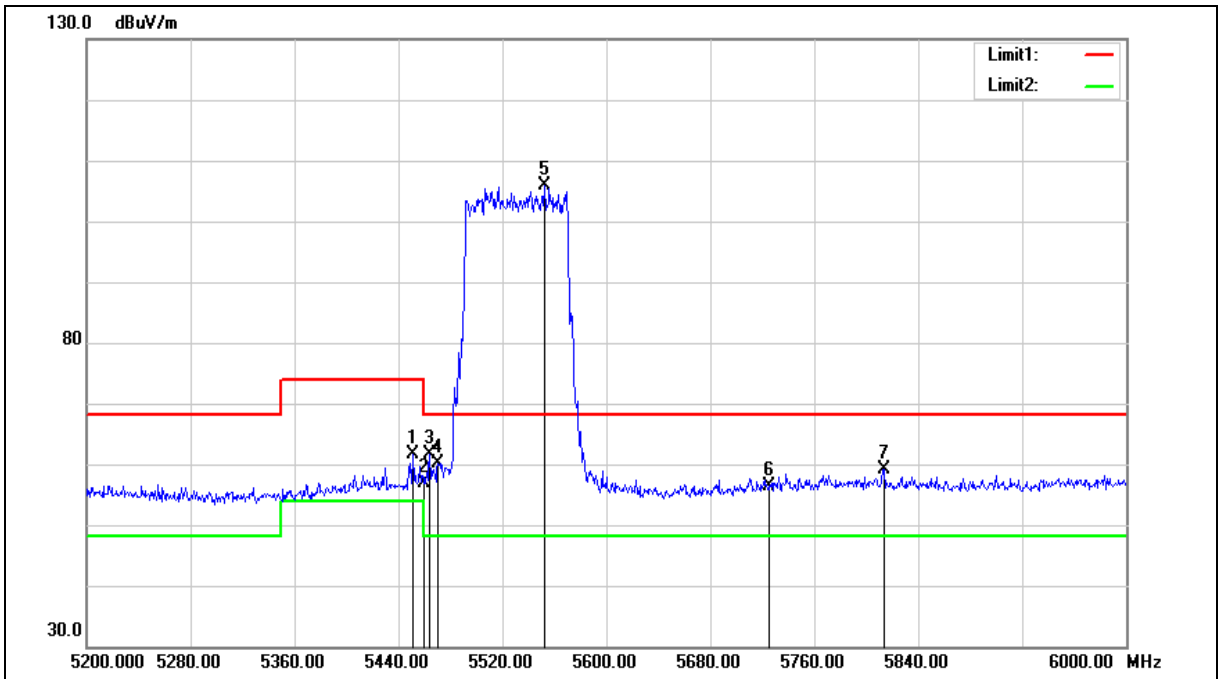

Standard:	FCC Part 15.407	Test Distance:	3 m
Test item:	Band edge		
Frequency:	5530 MHz		
Mode:	Mode 10		
Ant.Polar.:	Horizontal		

No.	Frequency (MHz)	Reading (dBuV)	Correct Factor (dB/m)	Result (dBuV/m)	Limit (dBuV/m)	Margin (dB)	Remark
1	5451.200	55.62	6.12	61.74	74.00	-12.26	peak
2	5460.000	50.71	6.14	56.85	74.00	-17.15	peak
3	5464.000	55.54	6.14	61.68	68.20	-6.52	peak
4	5470.000	54.00	6.15	60.15	68.20	-8.05	peak
5	5552.000	99.45	6.31	105.76	68.20	37.56	peak
6	5725.000	49.71	6.76	56.47	68.20	-11.73	peak
7	5813.600	52.20	6.97	59.17	68.20	-9.03	peak

Note:1.Result (dBuV/m) = Correct Factor (dB/m) + Reading(dBuV).

2.Correction factor (dB/m) = Antenna Factor (dB/m) + Cable loss (dB) – Pre-Amplifier gain (dB).

3.When the peak results are less than average limit, so not need to evaluate the average.

Standard:	FCC Part 15.407	Test Distance:	3 m
Test item:	Band edge		
Frequency:	5530 MHz		
Mode:	Mode 10		
Ant.Polar.:	Vertical		

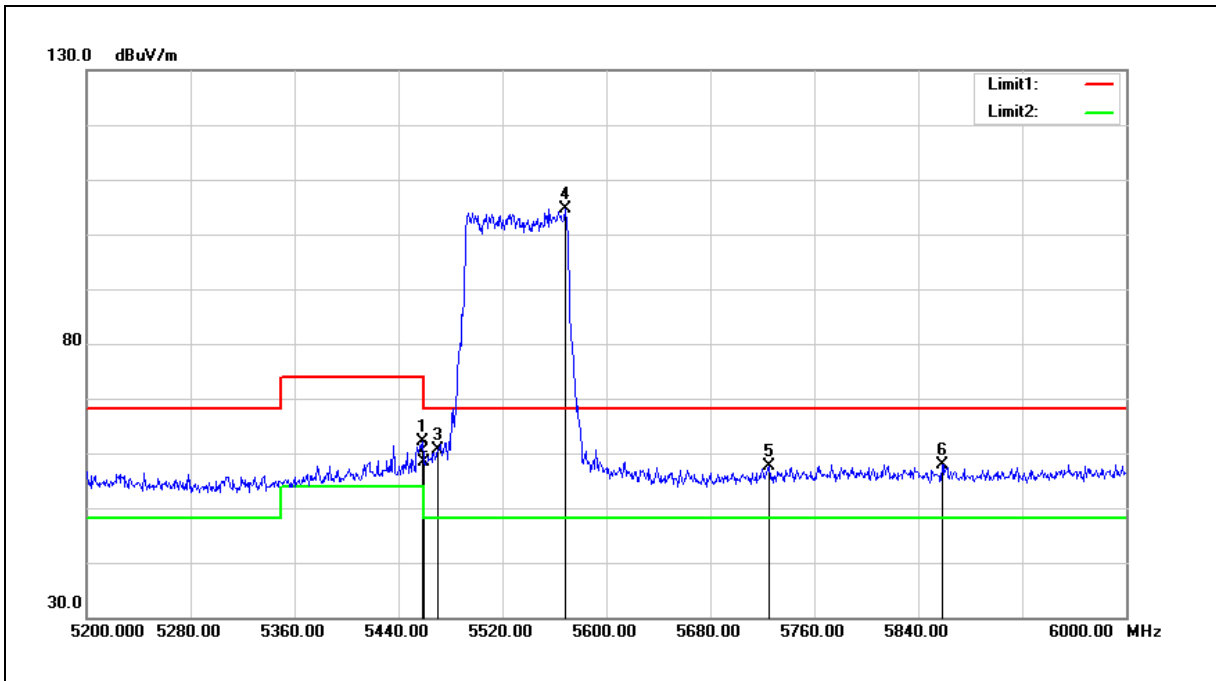

No.	Frequency (MHz)	Reading (dBuV)	Correct Factor (dB/m)	Result (dBuV/m)	Limit (dBuV/m)	Margin (dB)	Remark
1	5458.400	56.04	6.14	62.18	74.00	-11.82	peak
2	5460.000	52.17	6.14	58.31	74.00	-15.69	peak
3	5470.000	54.47	6.15	60.62	68.20	-7.58	peak
4	5568.000	98.31	6.36	104.67	68.20	36.47	peak
5	5725.000	50.86	6.76	57.62	68.20	-10.58	peak
6	5858.400	50.93	7.07	58.00	68.20	-10.20	peak

Note:1.Result (dBuV/m) = Correct Factor (dB/m) + Reading(dBuV).

2.Correction factor (dB/m) = Antenna Factor (dB/m) + Cable loss (dB) – Pre-Amplifier gain (dB).

3.When the peak results are less than average limit, so not need to evaluate the average.

Standard:	FCC Part 15.407	Test Distance:	3 m
Test item:	Band edge		
Frequency:	5690 MHz		
Mode:	Mode 10		
Ant.Polar.:	Horizontal		

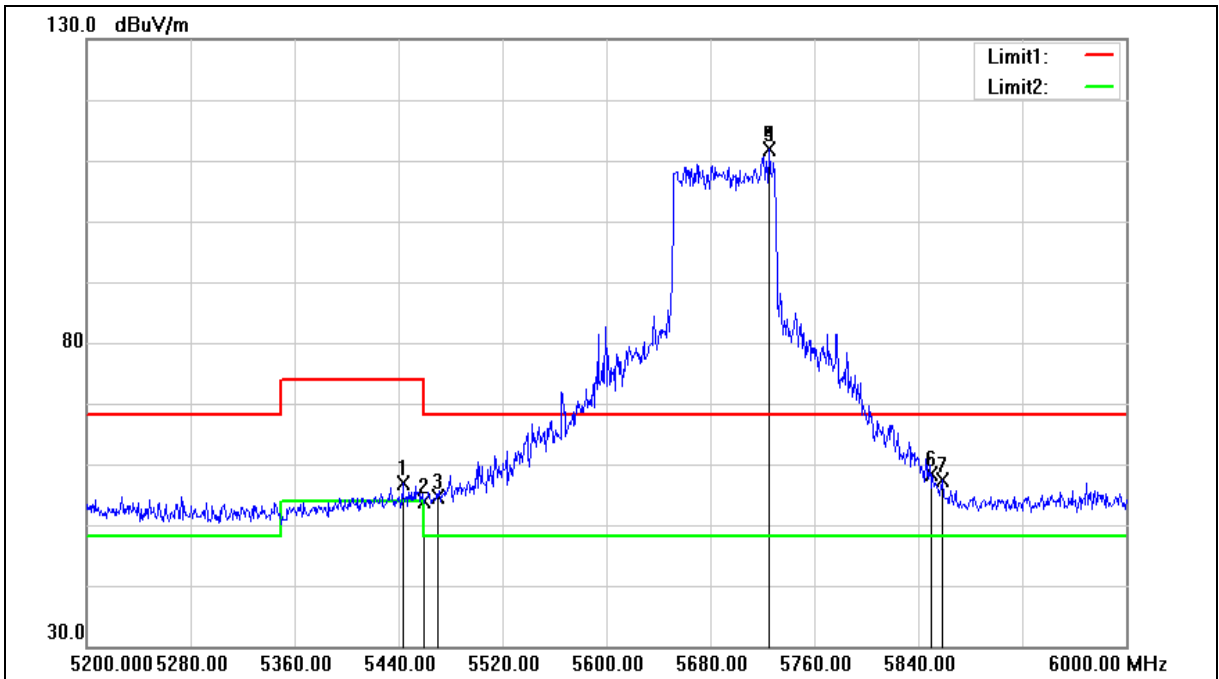

No.	Frequency (MHz)	Reading (dBuV)	Correct Factor (dB/m)	Result (dBuV/m)	Limit (dBuV/m)	Margin (dB)	Remark
1	5443.200	50.73	6.12	56.85	74.00	-17.15	peak
2	5460.000	47.64	6.14	53.78	74.00	-20.22	peak
3	5470.000	48.40	6.15	54.55	68.20	-13.65	peak
4	5725.000	105.12	6.76	111.88	68.20	43.68	peak
5	5725.600	105.12	6.76	111.88	68.20	43.68	peak
6	5850.000	51.35	7.05	58.40	68.20	-9.80	peak
7	5858.400	50.26	7.07	57.33	68.20	-10.87	peak

Note:1.Result (dBuV/m) = Correct Factor (dB/m) + Reading(dBuV).

2.Correction factor (dB/m) = Antenna Factor (dB/m) + Cable loss (dB) – Pre-Amplifier gain (dB).

3.When the peak results are less than average limit, so not need to evaluate the average.

Standard:	FCC Part 15.407	Test Distance:	3 m
Test item:	Band edge		
Frequency:	5690 MHz		
Mode:	Mode 10		
Ant.Polar.:	Vertical		

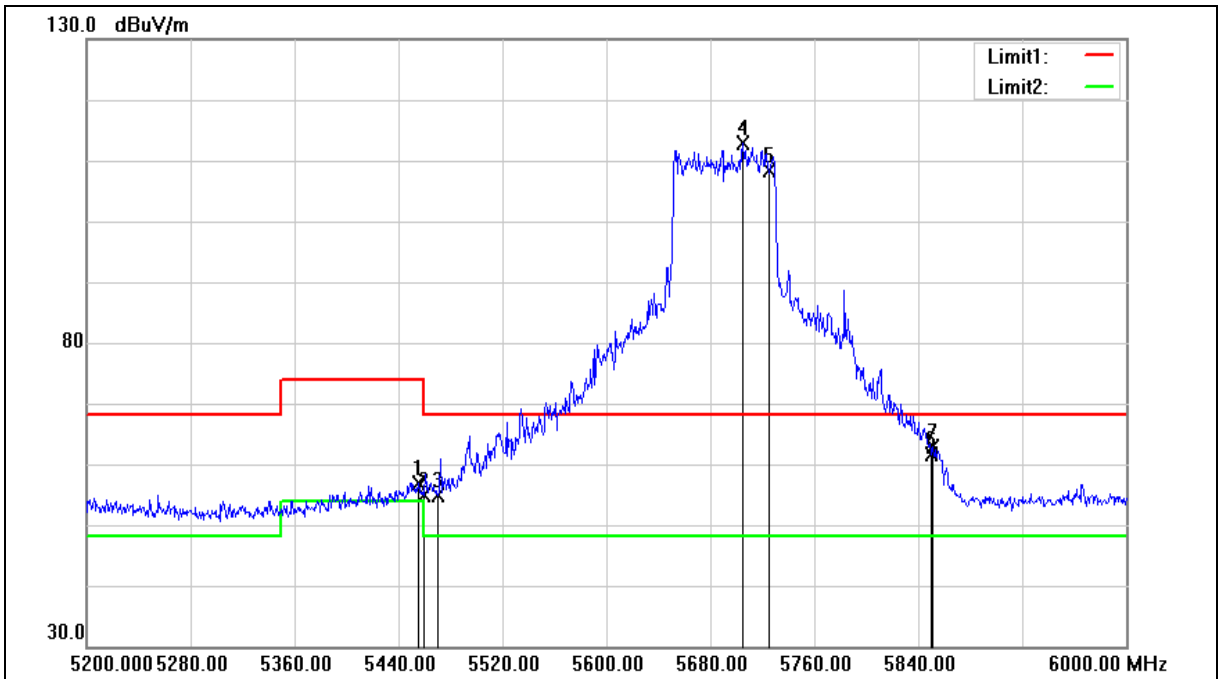

No.	Frequency (MHz)	Reading (dBuV)	Correct Factor (dB/m)	Result (dBuV/m)	Limit (dBuV/m)	Margin (dB)	Remark
1	5455.200	50.78	6.13	56.91	74.00	-17.09	peak
2	5460.000	48.64	6.14	54.78	74.00	-19.22	peak
3	5470.000	48.84	6.15	54.99	68.20	-13.21	peak
4	5704.800	106.14	6.70	112.84	68.20	44.64	peak
5	5725.000	101.65	6.76	108.41	68.20	40.21	peak
6	5850.000	54.63	7.05	61.68	68.20	-6.52	peak
7	5851.200	55.76	7.05	62.81	68.20	-5.39	peak

Note:1.Result (dBuV/m) = Correct Factor (dB/m) + Reading(dBuV).

2.Correction factor (dB/m) = Antenna Factor (dB/m) + Cable loss (dB) – Pre-Amplifier gain (dB).

3.When the peak results are less than average limit, so not need to evaluate the average.

Average

Standard:	FCC Part 15.407	Test Distance:	3 m
Test item:	Band edge		
Frequency:	5180 MHz		
Mode:	Mode 8		
Ant.Polar.:	Horizontal		

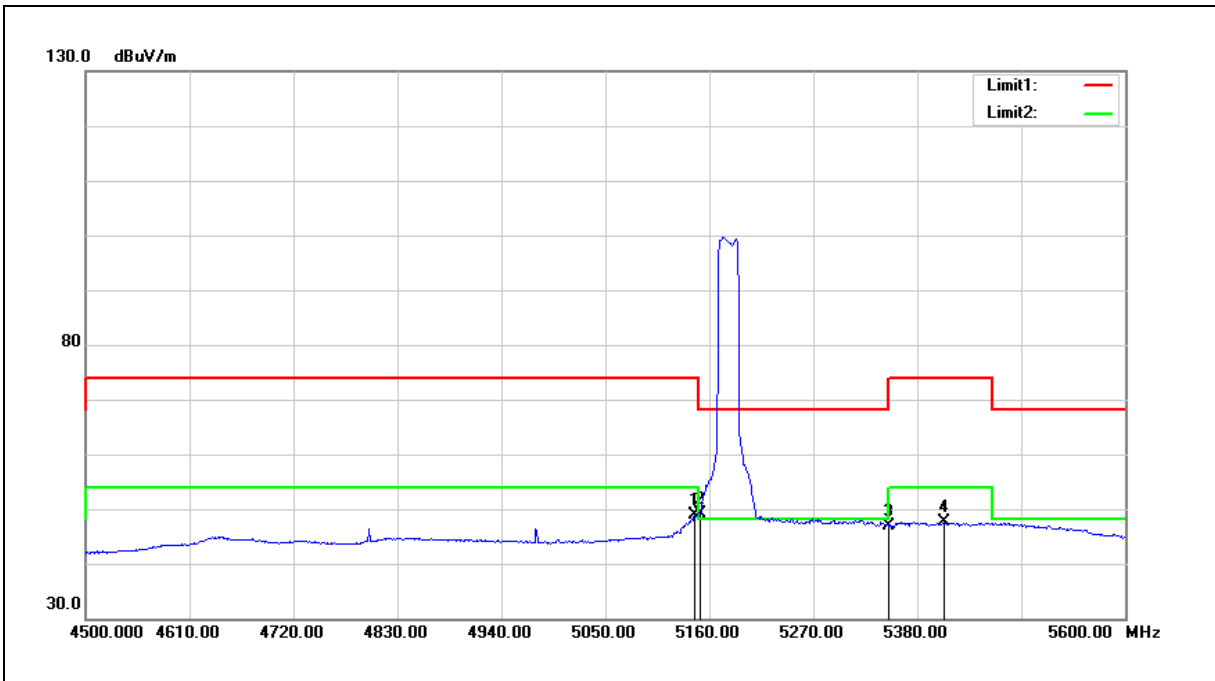

No.	Frequency (MHz)	Reading (dBuV)	Correct Factor (dB/m)	Result (dBuV/m)	Limit (dBuV/m)	Margin (dB)	Remark
1	5144.600	43.01	5.76	48.77	54.00	-5.23	AVG
2	5150.000	43.39	5.75	49.14	54.00	-4.86	AVG
3	5350.000	40.95	6.00	46.95	54.00	-7.05	AVG
4	5408.600	41.63	6.08	47.71	54.00	-6.29	AVG

Note:1.Result (dBuV/m) = Correct Factor (dB/m) + Reading(dBuV).

2.Correction factor (dB/m) = Antenna Factor (dB/m) + Cable loss (dB) – Pre-Amplifier gain (dB).

3.When the peak results are less than average limit, so not need to evaluate the average.

Standard:	FCC Part 15.407	Test Distance:	3 m
Test item:	Band edge		
Frequency:	5180 MHz		
Mode:	Mode 8		
Ant.Polar.:	Vertical		

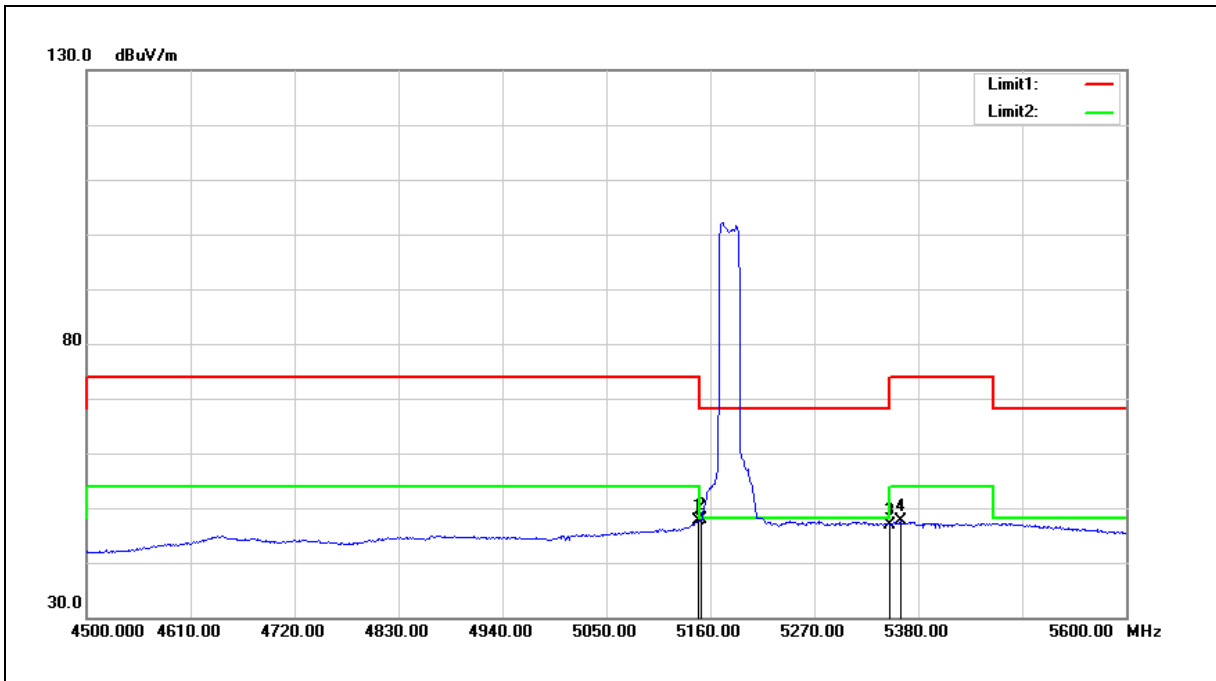

No.	Frequency (MHz)	Reading (dBuV)	Correct Factor (dB/m)	Result (dBuV/m)	Limit (dBuV/m)	Margin (dB)	Remark
1	5147.900	41.89	5.76	47.65	54.00	-6.35	AVG
2	5150.000	42.25	5.75	48.00	54.00	-6.00	AVG
3	5350.000	40.97	6.00	46.97	54.00	-7.03	AVG
4	5361.300	41.55	6.02	47.57	54.00	-6.43	AVG

Note:1.Result (dBuV/m) = Correct Factor (dB/m) + Reading(dBuV).

2.Correction factor (dB/m) = Antenna Factor (dB/m) + Cable loss (dB) – Pre-Amplifier gain (dB).

3.When the peak results are less than average limit, so not need to evaluate the average.

Standard:	FCC Part 15.407	Test Distance:	3 m
Test item:	Band edge		
Frequency:	5200 MHz		
Mode:	Mode 8		
Ant.Polar.:	Horizontal		

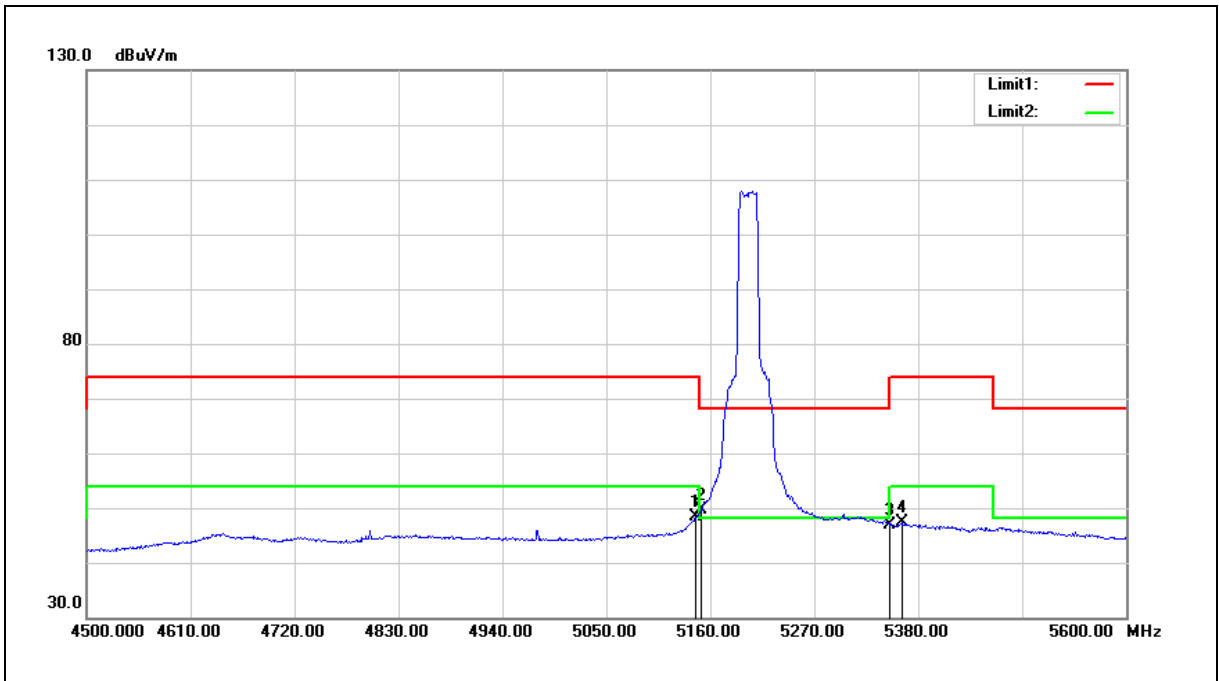

No.	Frequency (MHz)	Reading (dBuV)	Correct Factor (dB/m)	Result (dBuV/m)	Limit (dBuV/m)	Margin (dB)	Remark
1	5144.600	42.61	5.76	48.37	54.00	-5.63	AVG
2	5150.000	43.82	5.75	49.57	54.00	-4.43	AVG
3	5350.000	40.92	6.00	46.92	54.00	-7.08	AVG
4	5363.500	41.29	6.02	47.31	54.00	-6.69	AVG

Note:1.Result (dBuV/m) = Correct Factor (dB/m) + Reading(dBuV).

2.Correction factor (dB/m) = Antenna Factor (dB/m) + Cable loss (dB) – Pre-Amplifier gain (dB).

3.When the peak results are less than average limit, so not need to evaluate the average.

Standard:	FCC Part 15.407	Test Distance:	3 m
Test item:	Band edge		
Frequency:	5200 MHz		
Mode:	Mode 8		
Ant.Polar.:	Vertical		

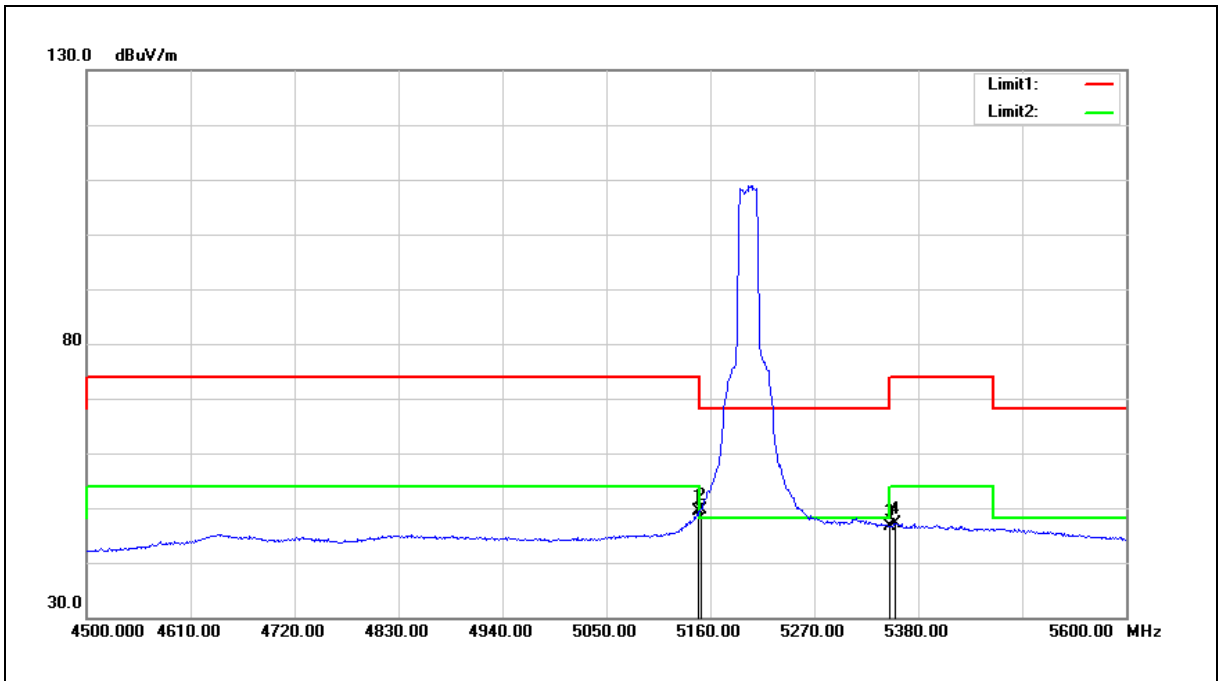

No.	Frequency (MHz)	Reading (dBuV)	Correct Factor (dB/m)	Result (dBuV/m)	Limit (dBuV/m)	Margin (dB)	Remark
1	5147.900	43.57	5.76	49.33	54.00	-4.67	AVG
2	5150.000	44.00	5.75	49.75	54.00	-4.25	AVG
3	5350.000	40.73	6.00	46.73	54.00	-7.27	AVG
4	5355.800	41.12	6.00	47.12	54.00	-6.88	AVG

Note:1.Result (dBuV/m) = Correct Factor (dB/m) + Reading(dBuV).

2.Correction factor (dB/m) = Antenna Factor (dB/m) + Cable loss (dB) – Pre-Amplifier gain (dB).

3.When the peak results are less than average limit, so not need to evaluate the average.

Standard:	FCC Part 15.407	Test Distance:	3 m
Test item:	Band edge		
Frequency:	5240 MHz		
Mode:	Mode 8		
Ant.Polar.:	Horizontal		

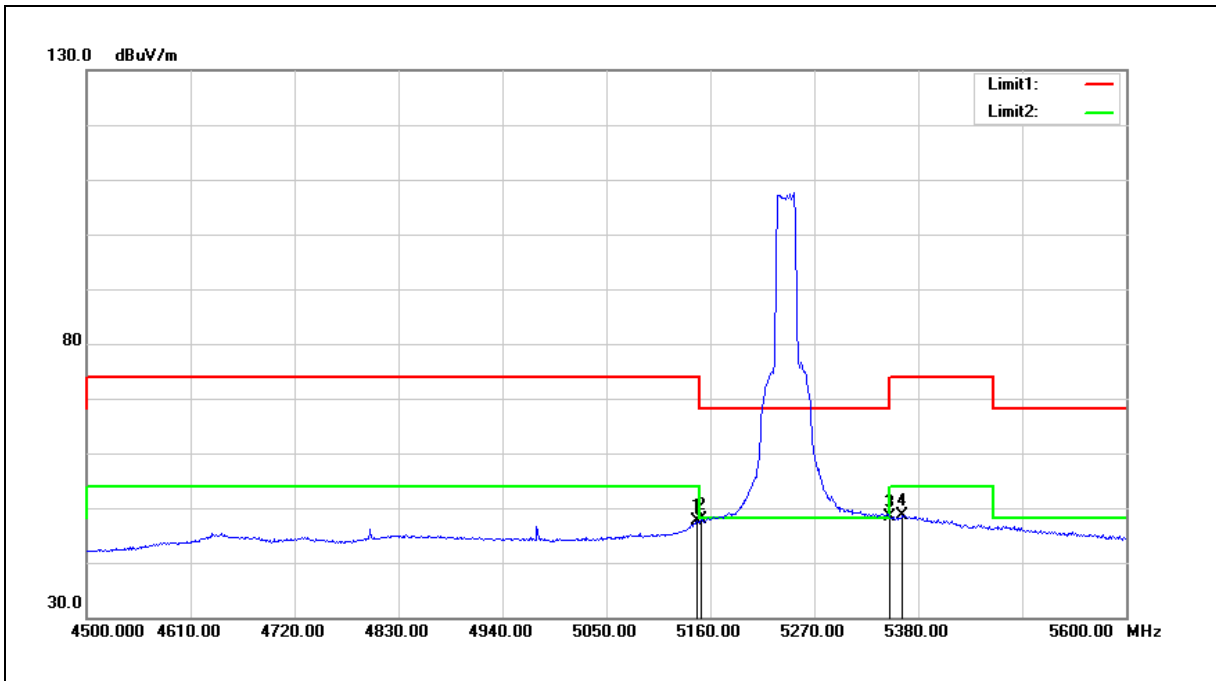

No.	Frequency (MHz)	Reading (dBuV)	Correct Factor (dB/m)	Result (dBuV/m)	Limit (dBuV/m)	Margin (dB)	Remark
1	5145.700	41.78	5.76	47.54	54.00	-6.46	AVG
2	5150.000	42.18	5.75	47.93	54.00	-6.07	AVG
3	5350.000	42.47	6.00	48.47	54.00	-5.53	AVG
4	5363.500	42.56	6.02	48.58	54.00	-5.42	AVG

Note:1.Result (dBuV/m) = Correct Factor (dB/m) + Reading(dBuV).

2.Correction factor (dB/m) = Antenna Factor (dB/m) + Cable loss (dB) – Pre-Amplifier gain (dB).

3.When the peak results are less than average limit, so not need to evaluate the average.

Standard:	FCC Part 15.407	Test Distance:	3 m
Test item:	Band edge		
Frequency:	5240 MHz		
Mode:	Mode 8		
Ant.Polar.:	Vertical		

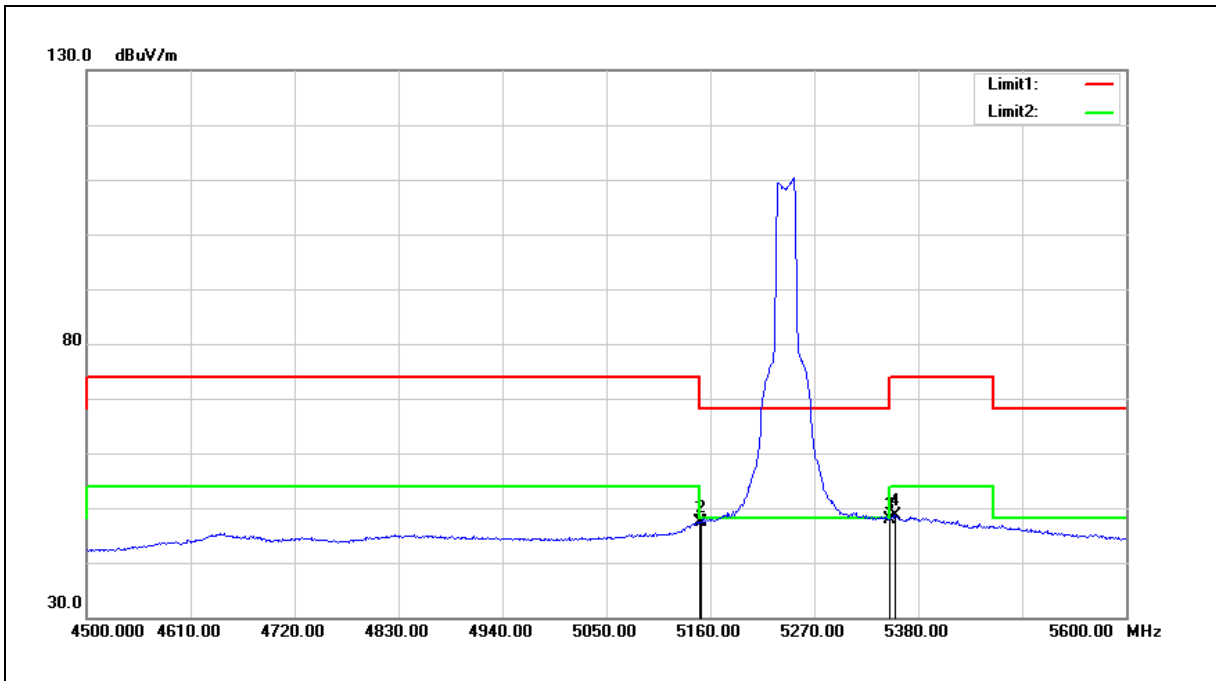

No.	Frequency (MHz)	Reading (dBuV)	Correct Factor (dB/m)	Result (dBuV/m)	Limit (dBuV/m)	Margin (dB)	Remark
1	5149.000	41.59	5.76	47.35	54.00	-6.65	AVG
2	5150.000	41.58	5.75	47.33	54.00	-6.67	AVG
3	5350.000	41.90	6.00	47.90	54.00	-6.10	AVG
4	5355.800	42.71	6.00	48.71	54.00	-5.29	AVG

Note:1.Result (dBuV/m) = Correct Factor (dB/m) + Reading(dBuV).

2.Correction factor (dB/m) = Antenna Factor (dB/m) + Cable loss (dB) – Pre-Amplifier gain (dB).

3.When the peak results are less than average limit, so not need to evaluate the average.

Standard:	FCC Part 15.407	Test Distance:	3 m
Test item:	Band edge		
Frequency:	5260 MHz		
Mode:	Mode 8		
Ant.Polar.:	Horizontal		

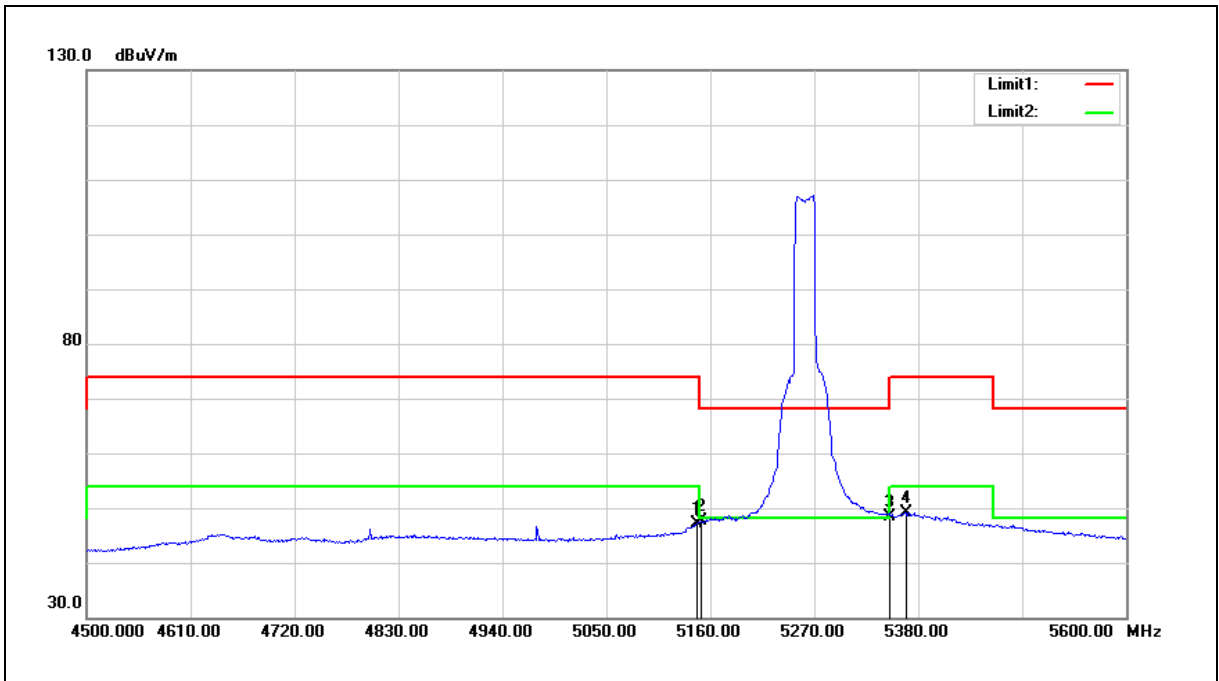

No.	Frequency (MHz)	Reading (dBuV)	Correct Factor (dB/m)	Result (dBuV/m)	Limit (dBuV/m)	Margin (dB)	Remark
1	5145.700	41.41	5.76	47.17	54.00	-6.83	AVG
2	5150.000	41.81	5.75	47.56	54.00	-6.44	AVG
3	5350.000	42.50	6.00	48.50	54.00	-5.50	AVG
4	5366.800	43.11	6.02	49.13	54.00	-4.87	AVG

Note:1.Result (dBuV/m) = Correct Factor (dB/m) + Reading(dBuV).

2.Correction factor (dB/m) = Antenna Factor (dB/m) + Cable loss (dB) – Pre-Amplifier gain (dB).

3.When the peak results are less than average limit, so not need to evaluate the average.

Standard:	FCC Part 15.407	Test Distance:	3 m
Test item:	Band edge		
Frequency:	5260 MHz		
Mode:	Mode 8		
Ant.Polar.:	Vertical		

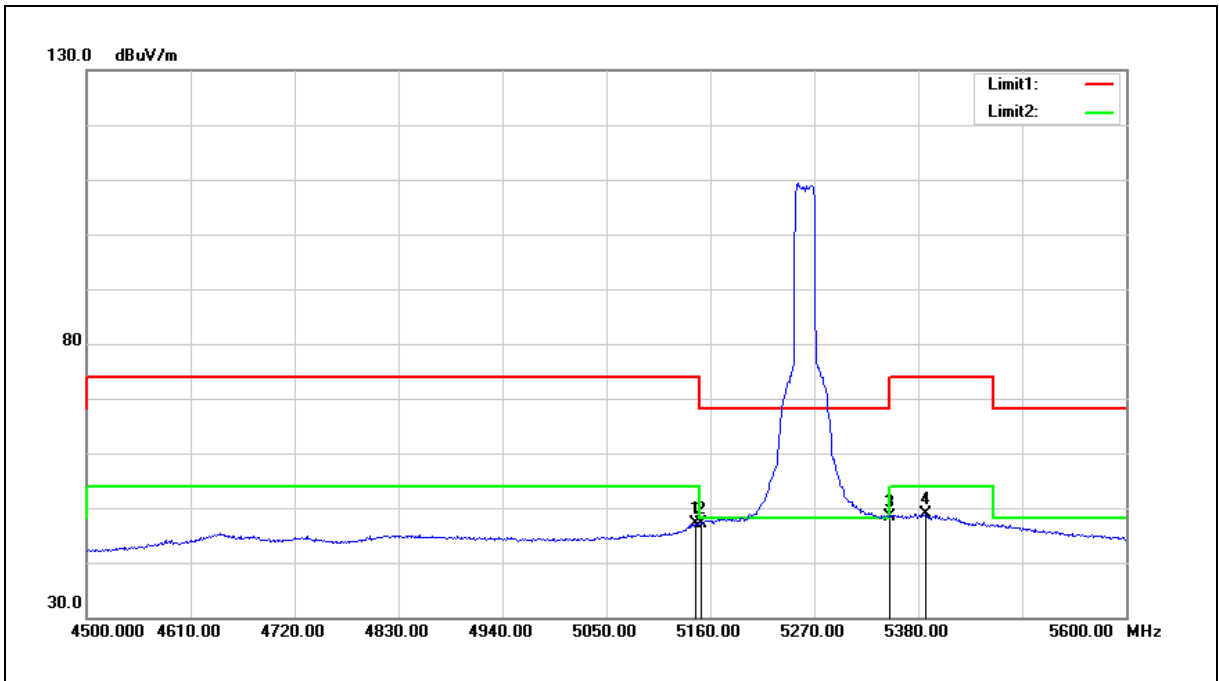

No.	Frequency (MHz)	Reading (dBuV)	Correct Factor (dB/m)	Result (dBuV/m)	Limit (dBuV/m)	Margin (dB)	Remark
1	5144.600	41.36	5.76	47.12	54.00	-6.88	AVG
2	5150.000	41.40	5.75	47.15	54.00	-6.85	AVG
3	5350.000	42.42	6.00	48.42	54.00	-5.58	AVG
4	5387.700	42.94	6.05	48.99	54.00	-5.01	AVG

Note:1.Result (dBuV/m) = Correct Factor (dB/m) + Reading(dBuV).

2.Correction factor (dB/m) = Antenna Factor (dB/m) + Cable loss (dB) – Pre-Amplifier gain (dB).

3.When the peak results are less than average limit, so not need to evaluate the average.

Standard:	FCC Part 15.407	Test Distance:	3 m
Test item:	Band edge		
Frequency:	5280 MHz		
Mode:	Mode 8		
Ant.Polar.:	Horizontal		

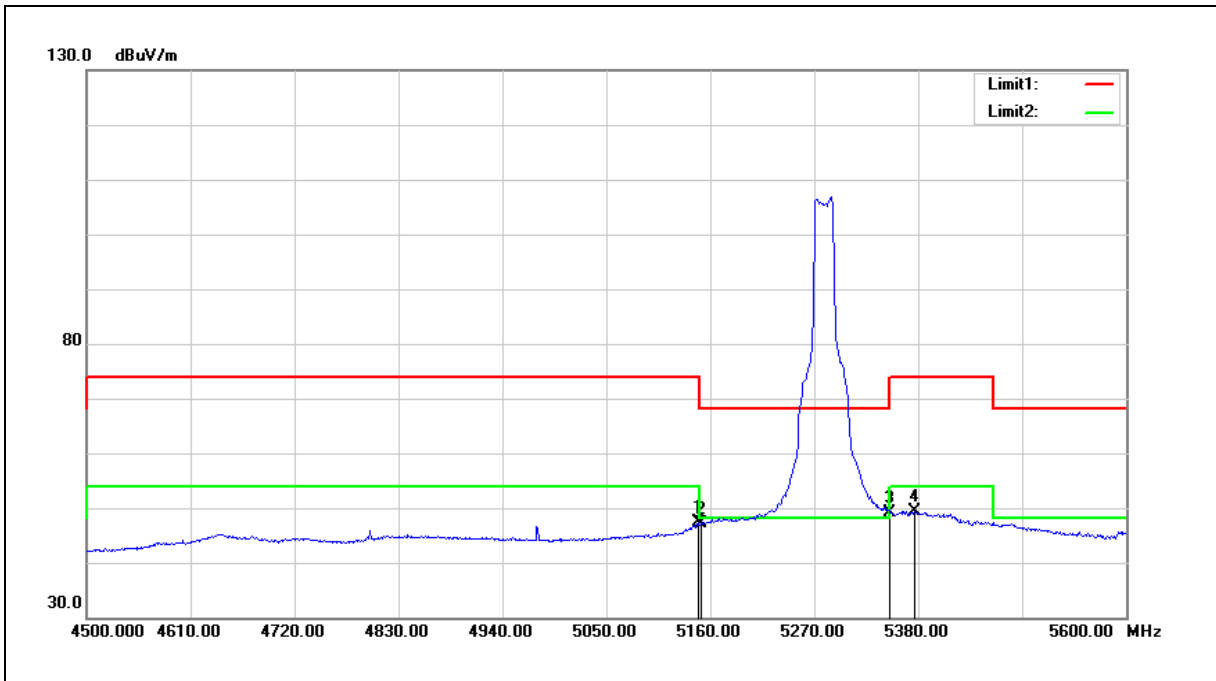

No.	Frequency (MHz)	Reading (dBuV)	Correct Factor (dB/m)	Result (dBuV/m)	Limit (dBuV/m)	Margin (dB)	Remark
1	5147.900	41.57	5.76	47.33	54.00	-6.67	AVG
2	5150.000	41.30	5.75	47.05	54.00	-6.95	AVG
3	5350.000	43.06	6.00	49.06	54.00	-4.94	AVG
4	5375.600	43.45	6.03	49.48	54.00	-4.52	AVG

Note:1.Result (dBuV/m) = Correct Factor (dB/m) + Reading(dBuV).

2.Correction factor (dB/m) = Antenna Factor (dB/m) + Cable loss (dB) – Pre-Amplifier gain (dB).

3.When the peak results are less than average limit, so not need to evaluate the average.

Standard:	FCC Part 15.407	Test Distance:	3 m
Test item:	Band edge		
Frequency:	5280 MHz		
Mode:	Mode 8		
Ant.Polar.:	Vertical		

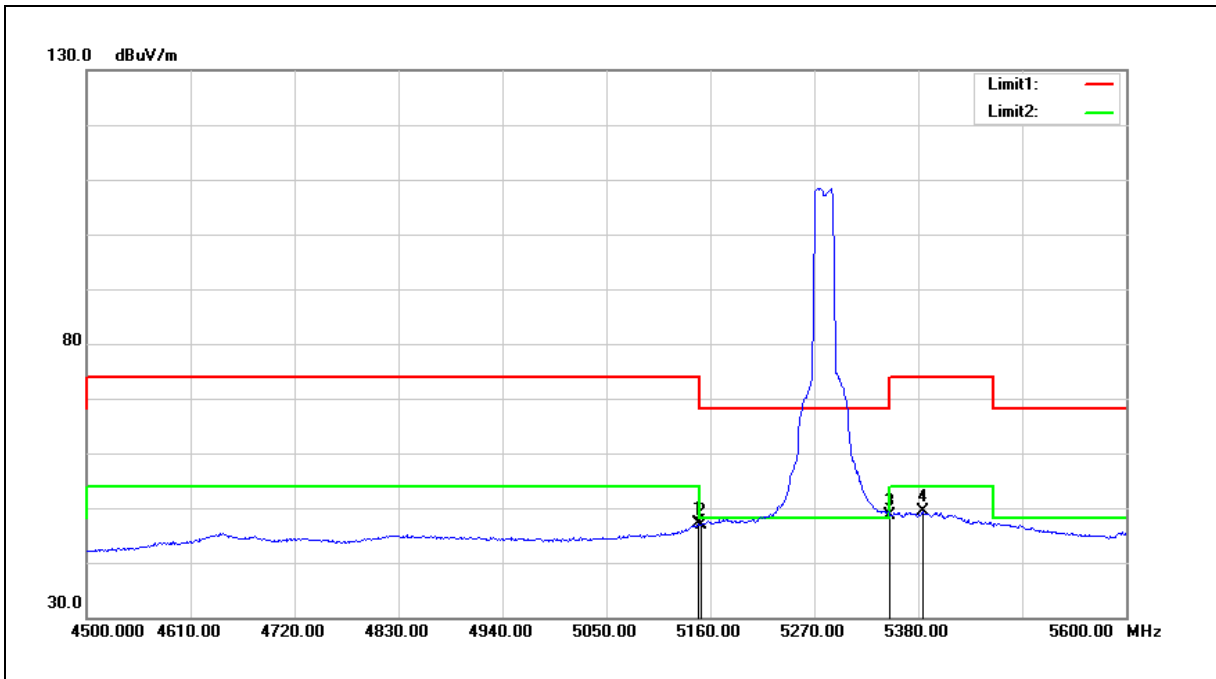

No.	Frequency (MHz)	Reading (dBuV)	Correct Factor (dB/m)	Result (dBuV/m)	Limit (dBuV/m)	Margin (dB)	Remark
1	5147.900	41.28	5.76	47.04	54.00	-6.96	AVG
2	5150.000	41.16	5.75	46.91	54.00	-7.09	AVG
3	5350.000	42.66	6.00	48.66	54.00	-5.34	AVG
4	5384.400	43.25	6.05	49.30	54.00	-4.70	AVG

Note:1.Result (dBuV/m) = Correct Factor (dB/m) + Reading(dBuV).

2.Correction factor (dB/m) = Antenna Factor (dB/m) + Cable loss (dB) – Pre-Amplifier gain (dB).

3.When the peak results are less than average limit, so not need to evaluate the average.

Standard:	FCC Part 15.407	Test Distance:	3 m
Test item:	Band edge		
Frequency:	5320 MHz		
Mode:	Mode 8		
Ant.Polar.:	Horizontal		

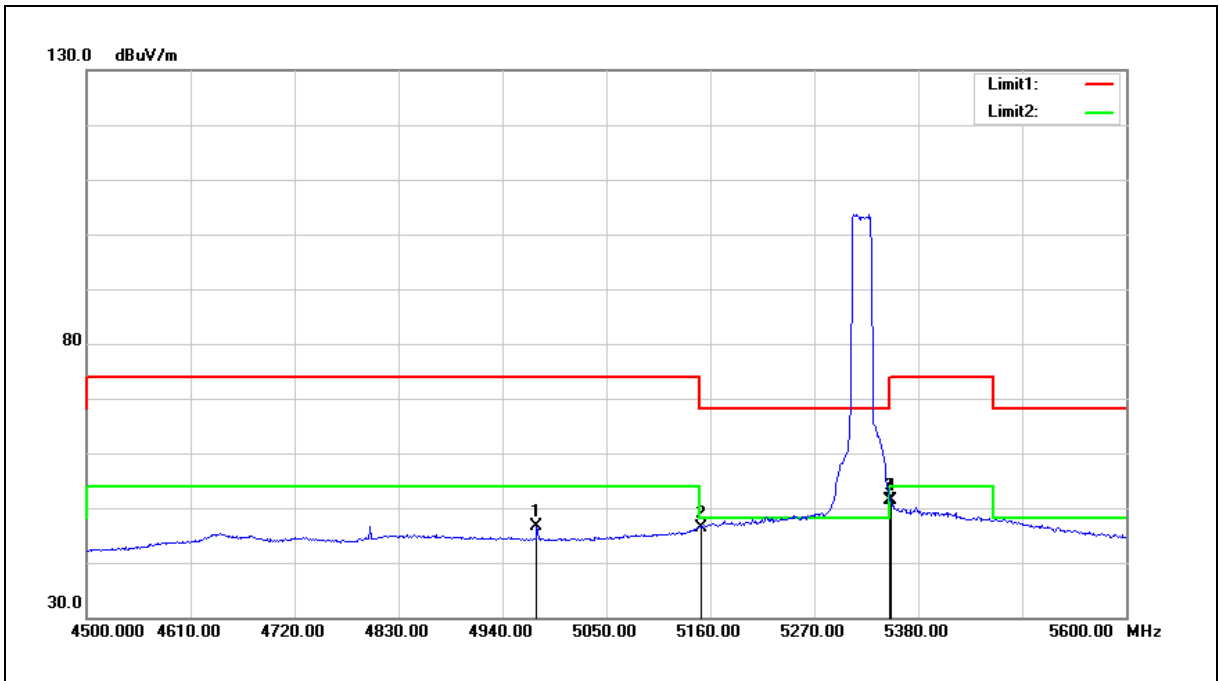

No.	Frequency (MHz)	Reading (dBuV)	Correct Factor (dB/m)	Result (dBuV/m)	Limit (dBuV/m)	Margin (dB)	Remark
1	4976.300	41.21	5.50	46.71	54.00	-7.29	AVG
2	5150.000	40.72	5.75	46.47	54.00	-7.53	AVG
3	5350.000	45.41	6.00	51.41	54.00	-2.59	AVG
4	5351.400	45.31	6.00	51.31	54.00	-2.69	AVG

Note:1.Result (dBuV/m) = Correct Factor (dB/m) + Reading(dBuV).

2.Correction factor (dB/m) = Antenna Factor (dB/m) + Cable loss (dB) – Pre-Amplifier gain (dB).

3.When the peak results are less than average limit, so not need to evaluate the average.

Standard:	FCC Part 15.407	Test Distance:	3 m
Test item:	Band edge		
Frequency:	5320 MHz		
Mode:	Mode 8		
Ant.Polar.:	Vertical		

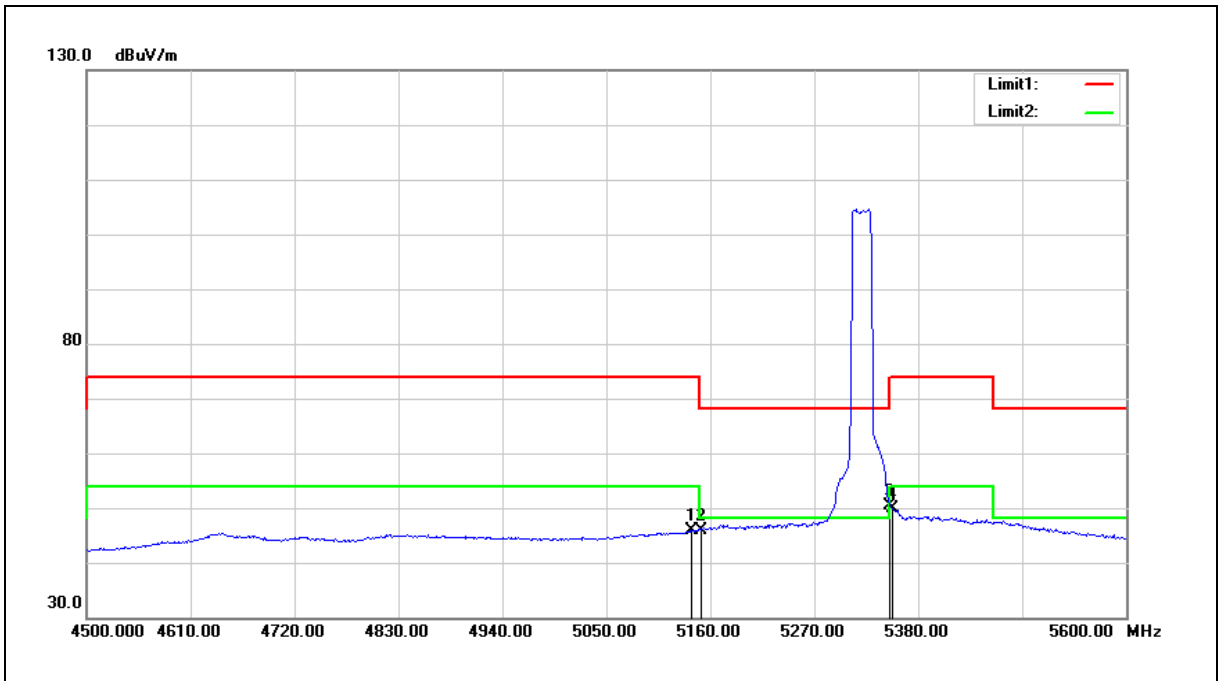

No.	Frequency (MHz)	Reading (dBuV)	Correct Factor (dB/m)	Result (dBuV/m)	Limit (dBuV/m)	Margin (dB)	Remark
1	5140.200	40.15	5.75	45.90	54.00	-8.10	AVG
2	5150.000	40.19	5.75	45.94	54.00	-8.06	AVG
3	5350.000	44.45	6.00	50.45	54.00	-3.55	AVG
4	5352.500	43.91	6.00	49.91	54.00	-4.09	AVG

Note:1.Result (dBuV/m) = Correct Factor (dB/m) + Reading(dBuV).

2.Correction factor (dB/m) = Antenna Factor (dB/m) + Cable loss (dB) – Pre-Amplifier gain (dB).

3.When the peak results are less than average limit, so not need to evaluate the average.

Standard:	FCC Part 15.407	Test Distance:	3 m
Test item:	Band edge		
Frequency:	5500 MHz		
Mode:	Mode 8		
Ant.Polar.:	Horizontal		

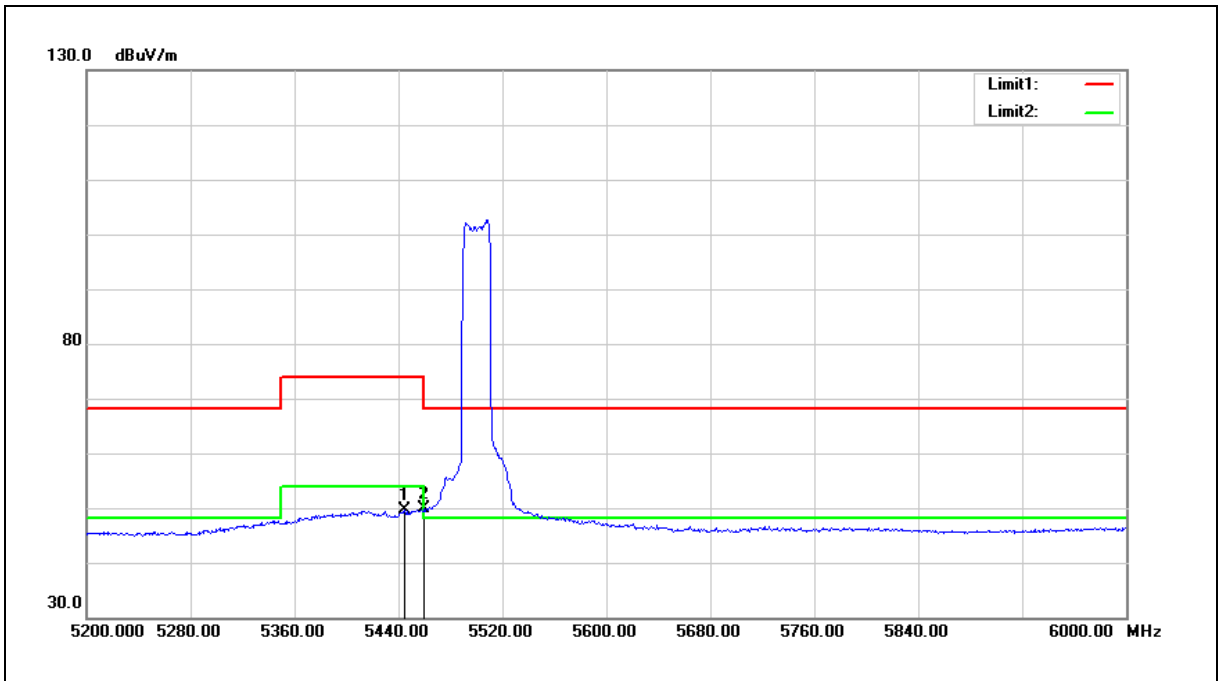

No.	Frequency (MHz)	Reading (dBuV)	Correct Factor (dB/m)	Result (dBuV/m)	Limit (dBuV/m)	Margin (dB)	Remark
1	5444.800	43.57	6.13	49.70	54.00	-4.30	AVG
2	5460.000	43.69	6.14	49.83	54.00	-4.17	AVG

Note:1.Result (dBuV/m) = Correct Factor (dB/m) + Reading(dBuV).

2.Correction factor (dB/m) = Antenna Factor (dB/m) + Cable loss (dB) – Pre-Amplifier gain (dB).

3.When the peak results are less than average limit, so not need to evaluate the average.

Standard:	FCC Part 15.407	Test Distance:	3 m
Test item:	Band edge		
Frequency:	5500 MHz		
Mode:	Mode 8		
Ant.Polar.:	Vertical		

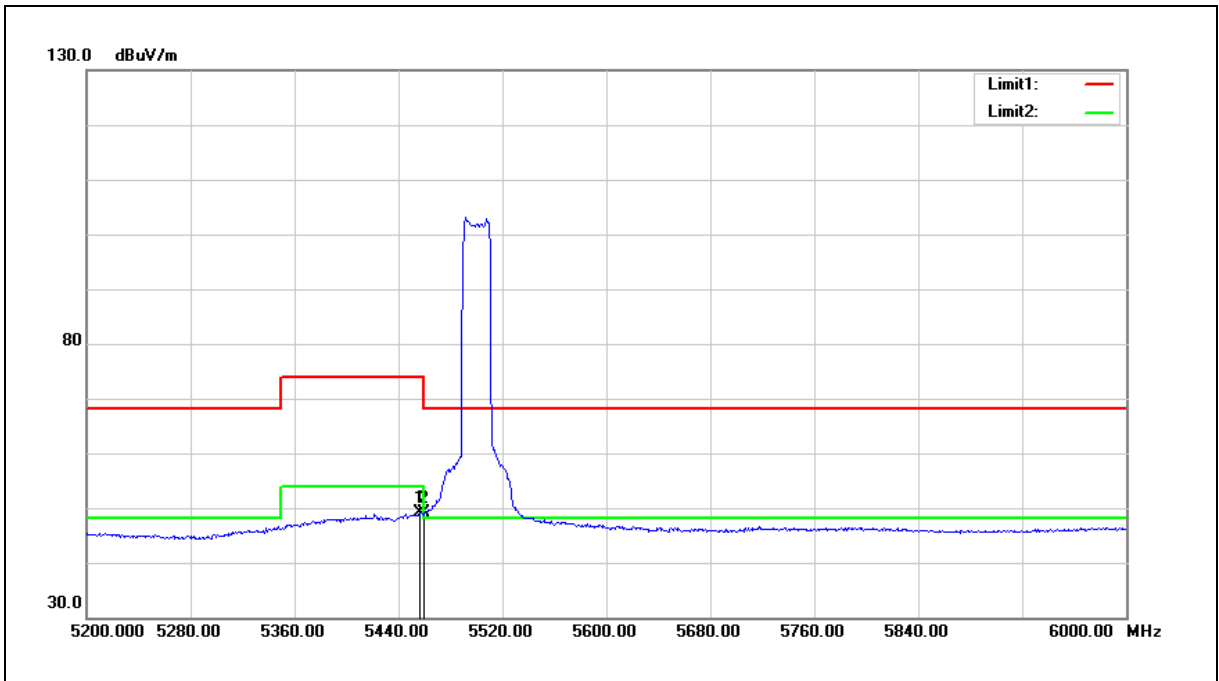

No.	Frequency (MHz)	Reading (dBuV)	Correct Factor (dB/m)	Result (dBuV/m)	Limit (dBuV/m)	Margin (dB)	Remark
1	5456.800	42.92	6.14	49.06	54.00	-4.94	AVG
2	5460.000	42.99	6.14	49.13	54.00	-4.87	AVG

Note:1.Result (dBuV/m) = Correct Factor (dB/m) + Reading(dBuV).

2.Correction factor (dB/m) = Antenna Factor (dB/m) + Cable loss (dB) – Pre-Amplifier gain (dB).

3.When the peak results are less than average limit, so not need to evaluate the average.

Standard:	FCC Part 15.407	Test Distance:	3 m
Test item:	Band edge		
Frequency:	5560 MHz		
Mode:	Mode 8		
Ant.Polar.:	Horizontal		

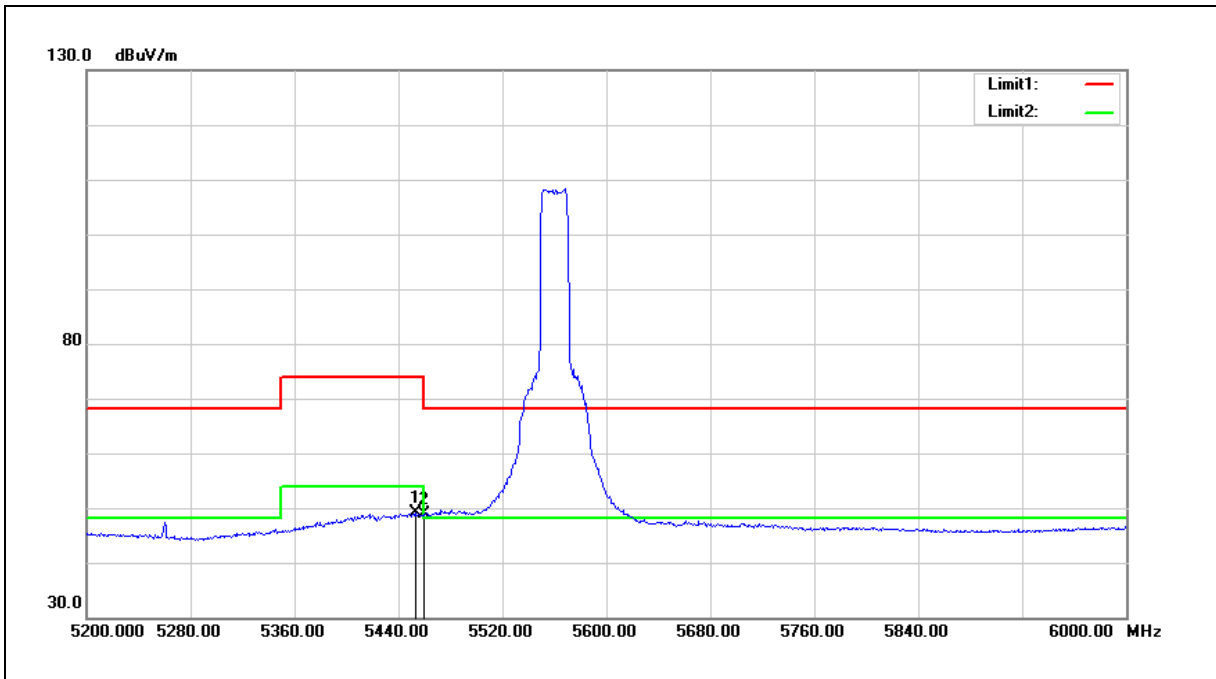

No.	Frequency (MHz)	Reading (dBuV)	Correct Factor (dB/m)	Result (dBuV/m)	Limit (dBuV/m)	Margin (dB)	Remark
1	5452.800	42.95	6.12	49.07	54.00	-4.93	AVG
2	5460.000	42.84	6.14	48.98	54.00	-5.02	AVG

- Note: 1. Result (dBuV/m) = Correct Factor (dB/m) + Reading (dBuV).
 2. Correction factor (dB/m) = Antenna Factor (dB/m) + Cable loss (dB) – Pre-Amplifier gain (dB).
 3. When the peak results are less than average limit, so not need to evaluate the average.

Standard:	FCC Part 15.407	Test Distance:	3 m
Test item:	Band edge		
Frequency:	5560 MHz		
Mode:	Mode 8		
Ant.Polar.:	Vertical		

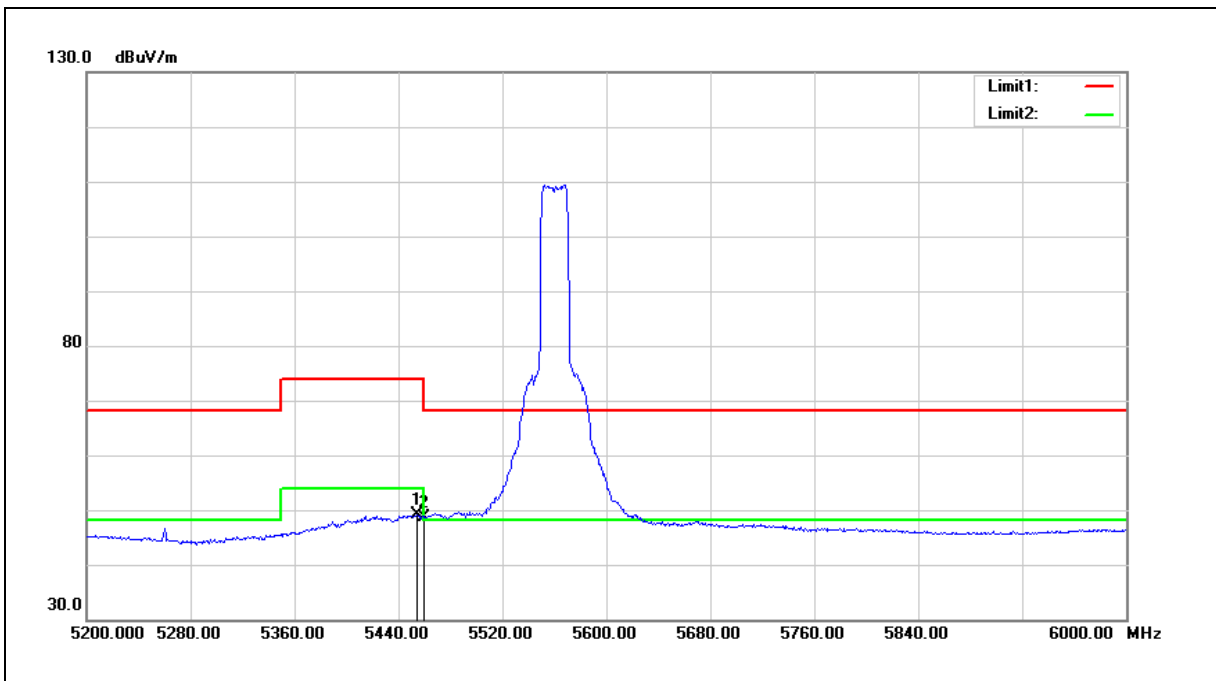

No.	Frequency (MHz)	Reading (dBuV)	Correct Factor (dB/m)	Result (dBuV/m)	Limit (dBuV/m)	Margin (dB)	Remark
1	5454.400	42.91	6.13	49.04	54.00	-4.96	AVG
2	5460.000	42.51	6.14	48.65	54.00	-5.35	AVG

- Note: 1.Result (dBuV/m) = Correct Factor (dB/m) + Reading(dBuV).
 2.Correction factor (dB/m) = Antenna Factor (dB/m) + Cable loss (dB) – Pre-Amplifier gain (dB).
 3.When the peak results are less than average limit, so not need to evaluate the average.

Standard:	FCC Part 15.407	Test Distance:	3 m
Test item:	Band edge		
Frequency:	5700 MHz		
Mode:	Mode 8		
Ant.Polar.:	Horizontal		

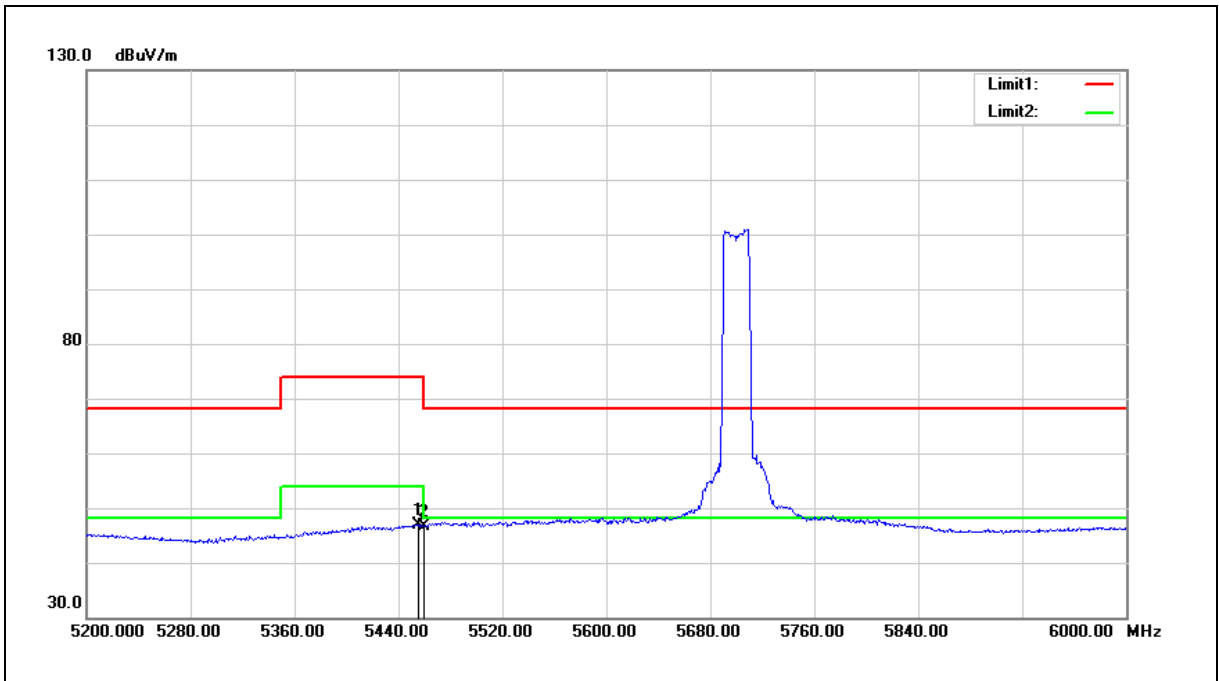

No.	Frequency (MHz)	Reading (dBuV)	Correct Factor (dB/m)	Result (dBuV/m)	Limit (dBuV/m)	Margin (dB)	Remark
1	5455.200	40.80	6.13	46.93	54.00	-7.07	AVG
2	5460.000	40.46	6.14	46.60	54.00	-7.40	AVG

Note:1.Result (dBuV/m) = Correct Factor (dB/m) + Reading(dBuV).

2.Correction factor (dB/m) = Antenna Factor (dB/m) + Cable loss (dB) – Pre-Amplifier gain (dB).

3.When the peak results are less than average limit, so not need to evaluate the average.

Standard:	FCC Part 15.407	Test Distance:	3 m
Test item:	Band edge		
Frequency:	5700 MHz		
Mode:	Mode 8		
Ant.Polar.:	Vertical		

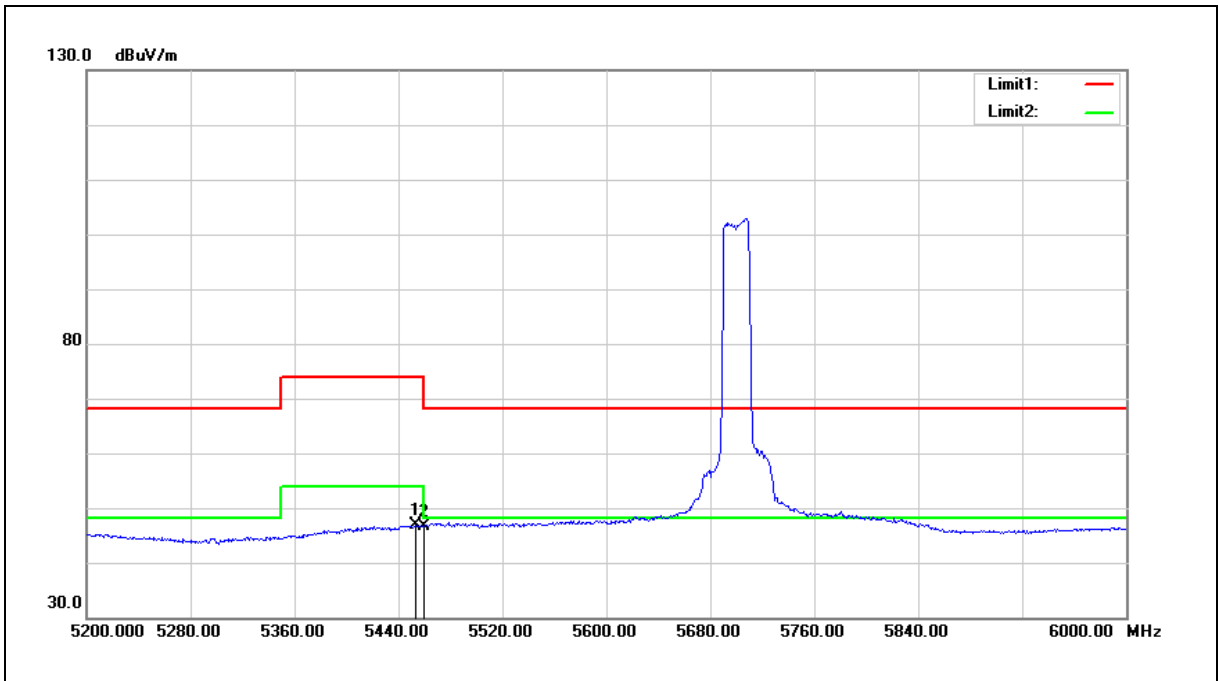

No.	Frequency (MHz)	Reading (dBuV)	Correct Factor (dB/m)	Result (dBuV/m)	Limit (dBuV/m)	Margin (dB)	Remark
1	5452.800	40.84	6.12	46.96	54.00	-7.04	AVG
2	5460.000	40.41	6.14	46.55	54.00	-7.45	AVG

Note:1.Result (dBuV/m) = Correct Factor (dB/m) + Reading(dBuV).

2.Correction factor (dB/m) = Antenna Factor (dB/m) + Cable loss (dB) – Pre-Amplifier gain (dB).

3.When the peak results are less than average limit, so not need to evaluate the average.

Standard:	FCC Part 15.407	Test Distance:	3 m
Test item:	Band edge		
Frequency:	5720 MHz		
Mode:	Mode 8		
Ant.Polar.:	Horizontal		

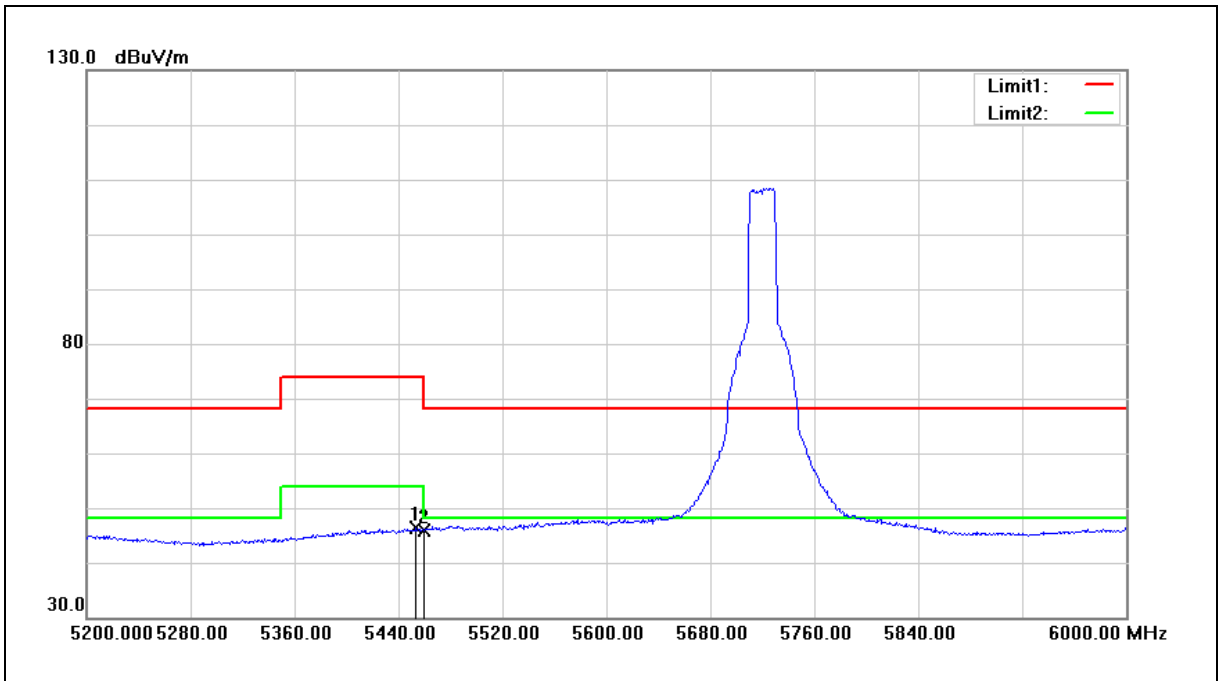

No.	Frequency (MHz)	Reading (dBuV)	Correct Factor (dB/m)	Result (dBuV/m)	Limit (dBuV/m)	Margin (dB)	Remark
1	5453.600	40.27	6.12	46.39	54.00	-7.61	AVG
2	5460.000	39.77	6.14	45.91	54.00	-8.09	AVG

Note:1.Result (dBuV/m) = Correct Factor (dB/m) + Reading(dBuV).

2.Correction factor (dB/m) = Antenna Factor (dB/m) + Cable loss (dB) – Pre-Amplifier gain (dB).

3.When the peak results are less than average limit, so not need to evaluate the average.

Standard:	FCC Part 15.407	Test Distance:	3 m
Test item:	Band edge		
Frequency:	5720 MHz		
Mode:	Mode 8		
Ant.Polar.:	Vertical		

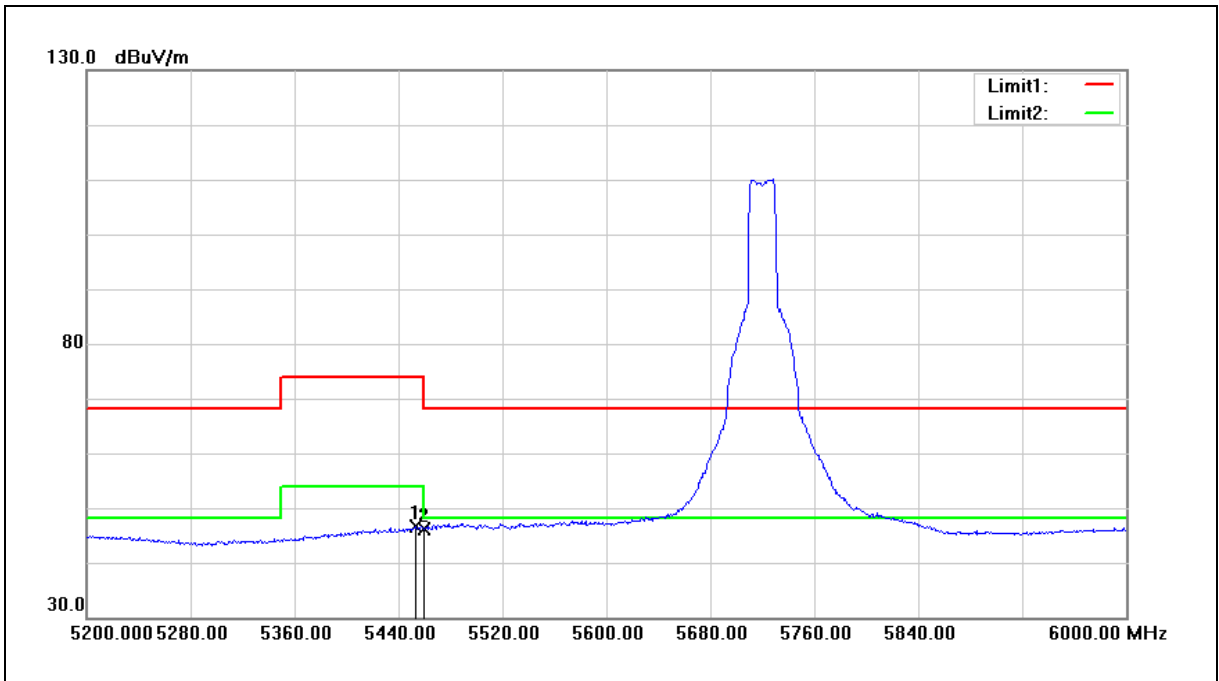

No.	Frequency (MHz)	Reading (dBuV)	Correct Factor (dB/m)	Result (dBuV/m)	Limit (dBuV/m)	Margin (dB)	Remark
1	5453.600	40.49	6.12	46.61	54.00	-7.39	AVG
2	5460.000	40.00	6.14	46.14	54.00	-7.86	AVG

Note:1.Result (dBuV/m) = Correct Factor (dB/m) + Reading(dBuV).

2.Correction factor (dB/m) = Antenna Factor (dB/m) + Cable loss (dB) – Pre-Amplifier gain (dB).

3.When the peak results are less than average limit, so not need to evaluate the average.

Standard:	FCC Part 15.407	Test Distance:	3 m
Test item:	Band edge		
Frequency:	5190 MHz		
Mode:	Mode 9		
Ant.Polar.:	Horizontal		

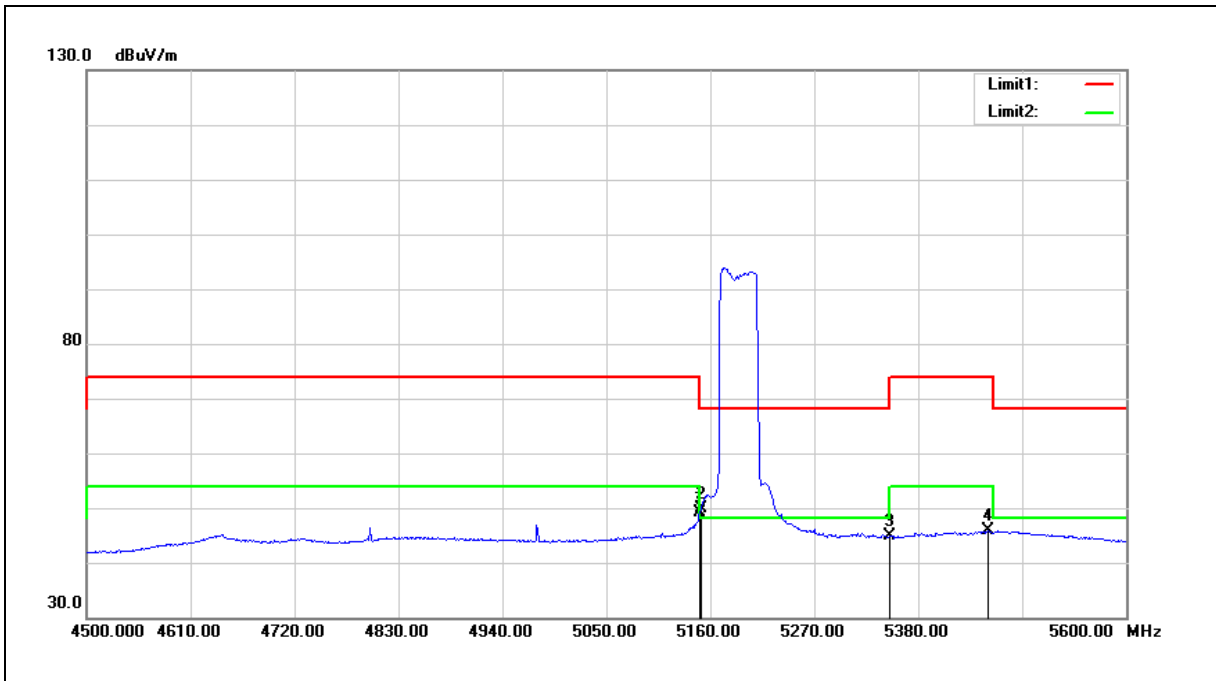

No.	Frequency (MHz)	Reading (dBuV)	Correct Factor (dB/m)	Result (dBuV/m)	Limit (dBuV/m)	Margin (dB)	Remark
1	5149.000	43.37	5.76	49.13	54.00	-4.87	AVG
2	5150.000	44.05	5.75	49.80	54.00	-4.20	AVG
3	5350.000	38.92	6.00	44.92	54.00	-9.08	AVG
4	5453.700	39.73	6.12	45.85	54.00	-8.15	AVG

Note:1.Result (dBuV/m) = Correct Factor (dB/m) + Reading(dBuV).

2.Correction factor (dB/m) = Antenna Factor (dB/m) + Cable loss (dB) – Pre-Amplifier gain (dB).

3.When the peak results are less than average limit, so not need to evaluate the average.

Standard:	FCC Part 15.407	Test Distance:	3 m
Test item:	Band edge		
Frequency:	5190 MHz		
Mode:	Mode 9		
Ant.Polar.:	Vertical		

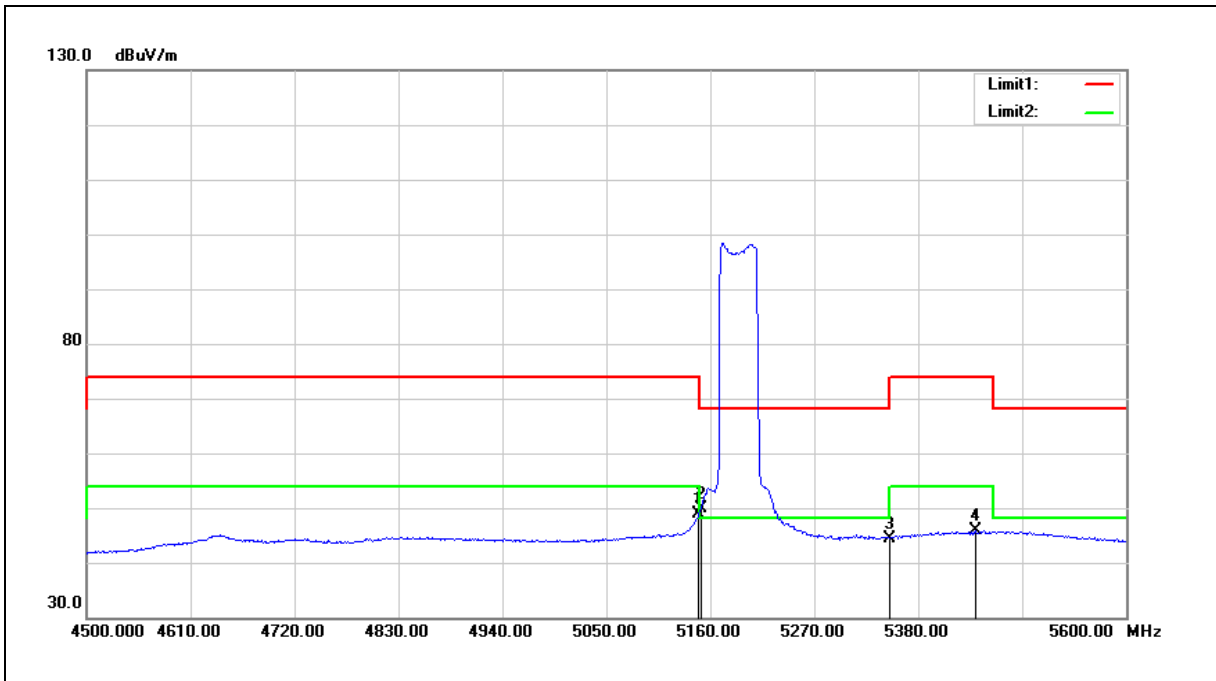

No.	Frequency (MHz)	Reading (dBuV)	Correct Factor (dB/m)	Result (dBuV/m)	Limit (dBuV/m)	Margin (dB)	Remark
1	5147.900	43.04	5.76	48.80	54.00	-5.20	AVG
2	5150.000	44.15	5.75	49.90	54.00	-4.10	AVG
3	5350.000	38.47	6.00	44.47	54.00	-9.53	AVG
4	5440.500	39.70	6.12	45.82	54.00	-8.18	AVG

Note:1.Result (dBuV/m) = Correct Factor (dB/m) + Reading(dBuV).

2.Correction factor (dB/m) = Antenna Factor (dB/m) + Cable loss (dB) – Pre-Amplifier gain (dB).

3.When the peak results are less than average limit, so not need to evaluate the average.

Standard:	FCC Part 15.407	Test Distance:	3 m
Test item:	Band edge		
Frequency:	5230 MHz		
Mode:	Mode 9		
Ant.Polar.:	Horizontal		

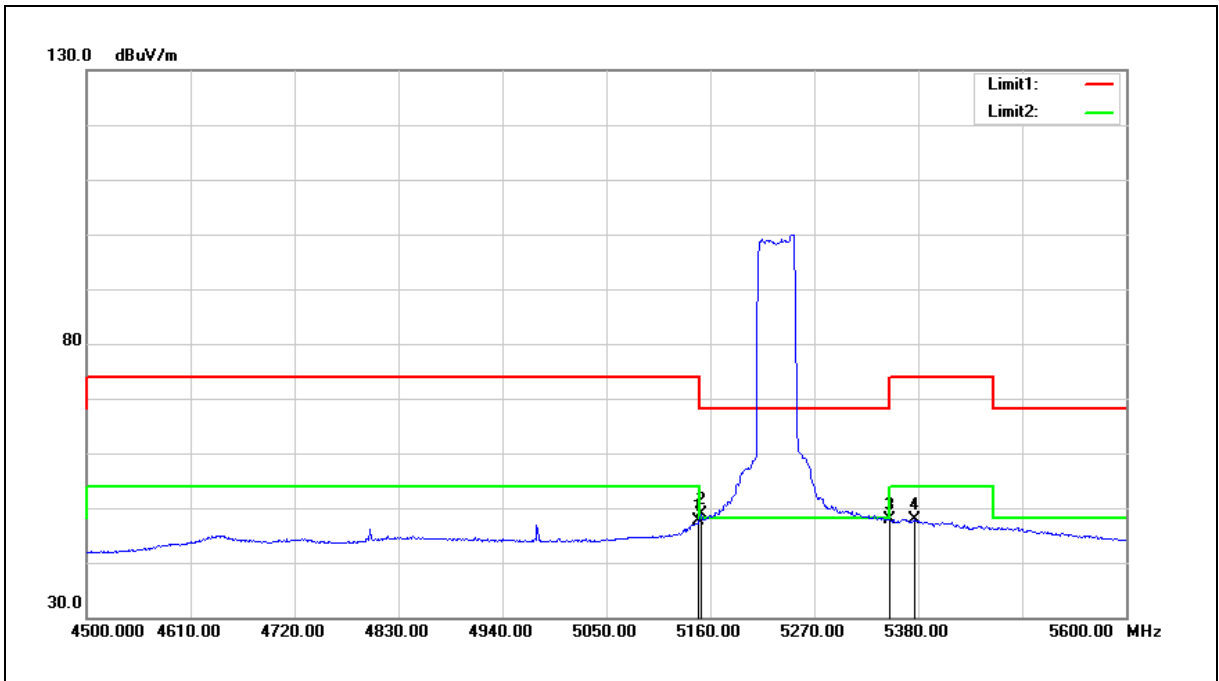

No.	Frequency (MHz)	Reading (dBuV)	Correct Factor (dB/m)	Result (dBuV/m)	Limit (dBuV/m)	Margin (dB)	Remark
1	5147.900	41.81	5.76	47.57	54.00	-6.43	AVG
2	5150.000	43.01	5.75	48.76	54.00	-5.24	AVG
3	5350.000	41.93	6.00	47.93	54.00	-6.07	AVG
4	5376.700	41.92	6.03	47.95	54.00	-6.05	AVG

Note:1.Result (dBuV/m) = Correct Factor (dB/m) + Reading(dBuV).

2.Correction factor (dB/m) = Antenna Factor (dB/m) + Cable loss (dB) – Pre-Amplifier gain (dB).

3.When the peak results are less than average limit, so not need to evaluate the average.

Standard:	FCC Part 15.407	Test Distance:	3 m
Test item:	Band edge		
Frequency:	5230 MHz		
Mode:	Mode 9		
Ant.Polar.:	Vertical		

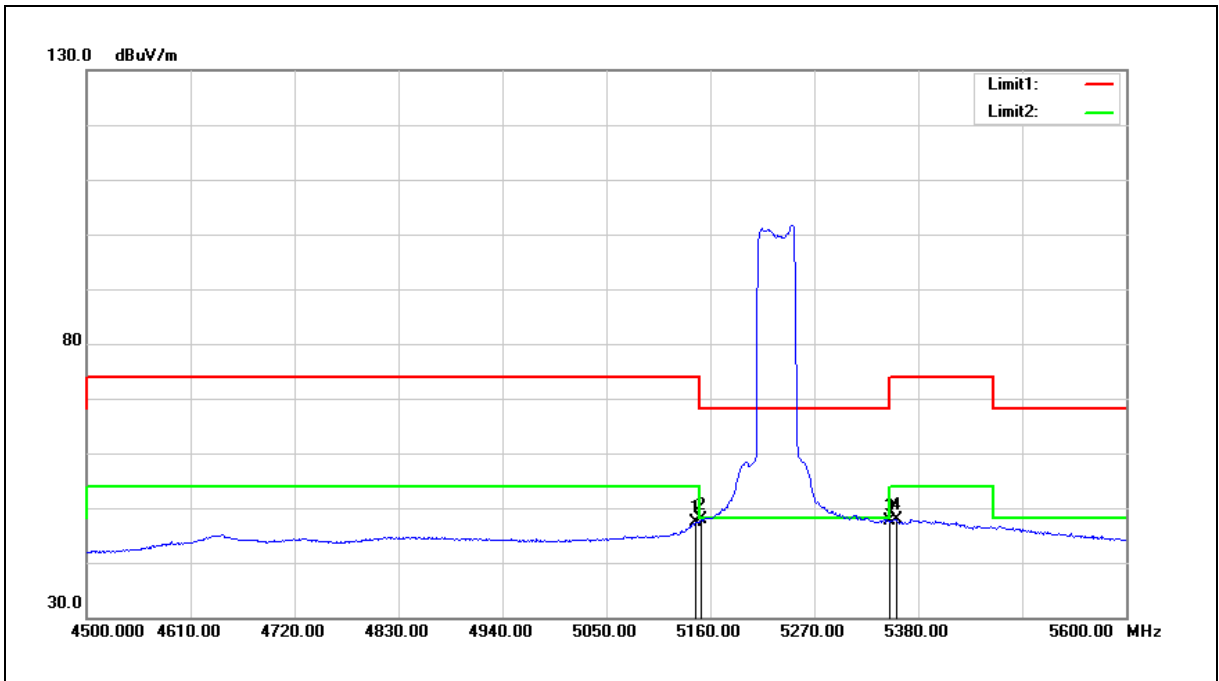

No.	Frequency (MHz)	Reading (dBuV)	Correct Factor (dB/m)	Result (dBuV/m)	Limit (dBuV/m)	Margin (dB)	Remark
1	5144.600	41.59	5.76	47.35	54.00	-6.65	AVG
2	5150.000	42.08	5.75	47.83	54.00	-6.17	AVG
3	5350.000	41.51	6.00	47.51	54.00	-6.49	AVG
4	5356.900	41.81	6.01	47.82	54.00	-6.18	AVG

Note:1.Result (dBuV/m) = Correct Factor (dB/m) + Reading(dBuV).

2.Correction factor (dB/m) = Antenna Factor (dB/m) + Cable loss (dB) – Pre-Amplifier gain (dB).

3.When the peak results are less than average limit, so not need to evaluate the average.

Standard:	FCC Part 15.407	Test Distance:	3 m
Test item:	Band edge		
Frequency:	5270 MHz		
Mode:	Mode 9		
Ant.Polar.:	Horizontal		

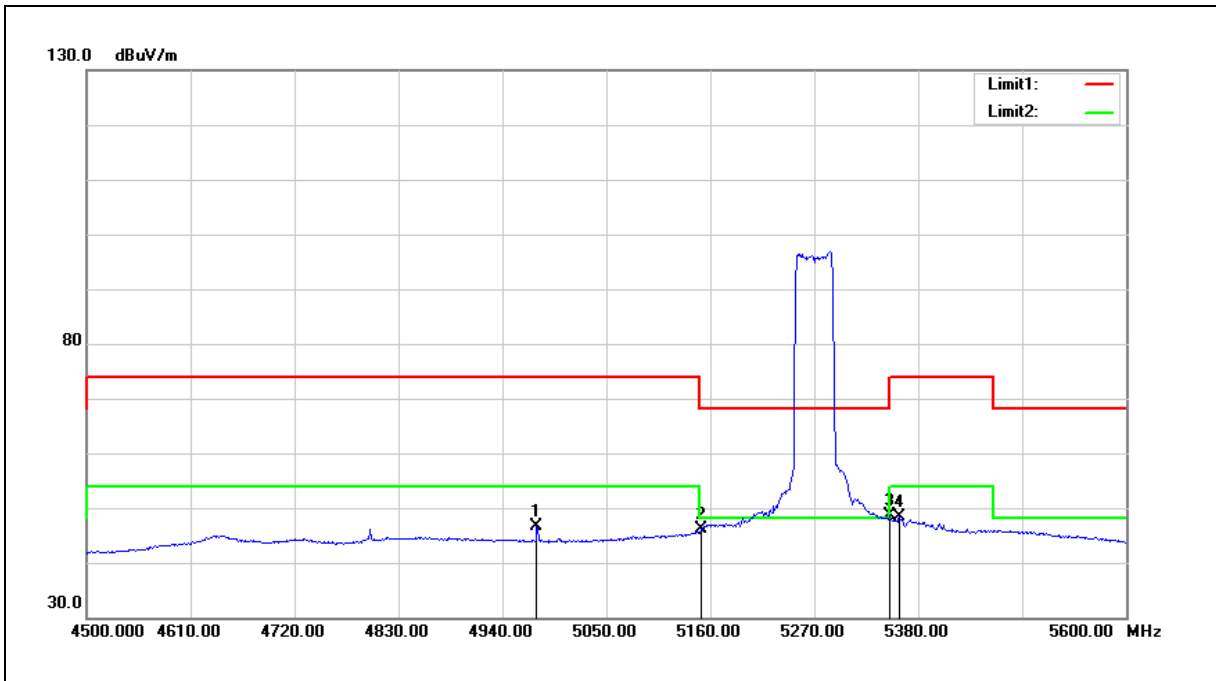

No.	Frequency (MHz)	Reading (dBuV)	Correct Factor (dB/m)	Result (dBuV/m)	Limit (dBuV/m)	Margin (dB)	Remark
1	4976.300	41.08	5.50	46.58	54.00	-7.42	AVG
2	5150.000	40.30	5.75	46.05	54.00	-7.95	AVG
3	5350.000	42.55	6.00	48.55	54.00	-5.45	AVG
4	5360.200	42.26	6.01	48.27	54.00	-5.73	AVG

Note:1.Result (dBuV/m) = Correct Factor (dB/m) + Reading(dBuV).

2.Correction factor (dB/m) = Antenna Factor (dB/m) + Cable loss (dB) – Pre-Amplifier gain (dB).

3.When the peak results are less than average limit, so not need to evaluate the average.

Standard:	FCC Part 15.407	Test Distance:	3 m
Test item:	Band edge		
Frequency:	5270 MHz		
Mode:	Mode 9		
Ant.Polar.:	Vertical		

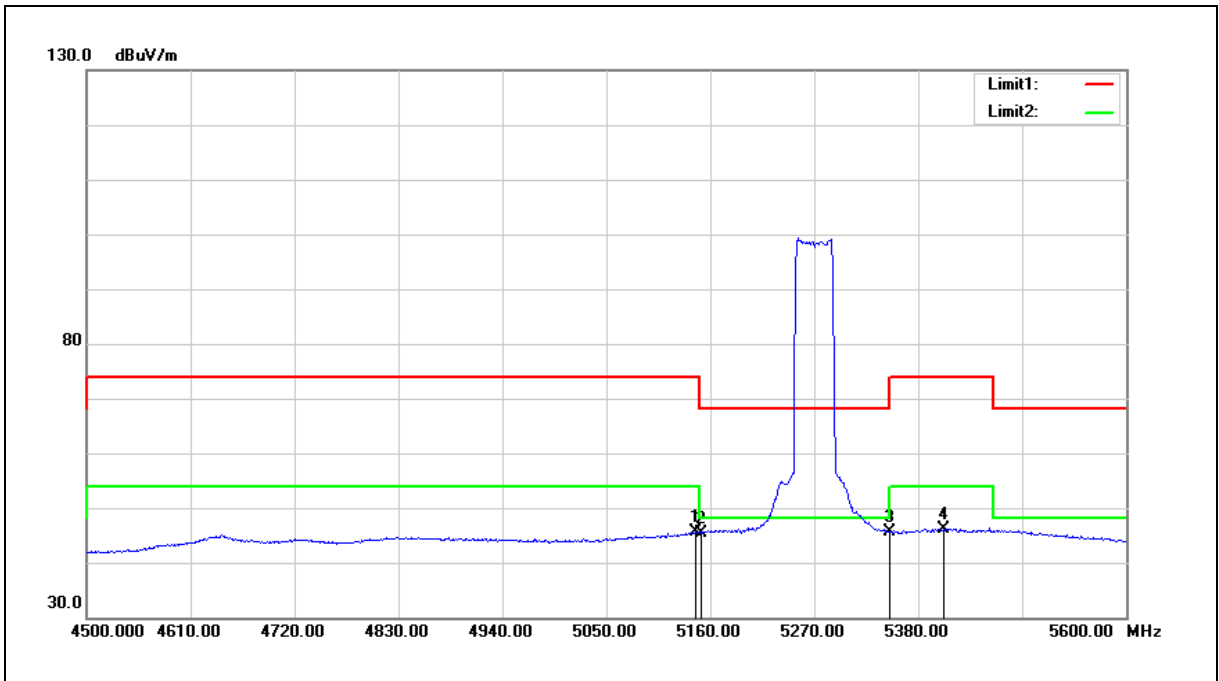

No.	Frequency (MHz)	Reading (dBuV)	Correct Factor (dB/m)	Result (dBuV/m)	Limit (dBuV/m)	Margin (dB)	Remark
1	5144.600	39.88	5.76	45.64	54.00	-8.36	AVG
2	5150.000	39.72	5.75	45.47	54.00	-8.53	AVG
3	5350.000	39.66	6.00	45.66	54.00	-8.34	AVG
4	5406.400	40.13	6.08	46.21	54.00	-7.79	AVG

Note:1.Result (dBuV/m) = Correct Factor (dB/m) + Reading(dBuV).

2.Correction factor (dB/m) = Antenna Factor (dB/m) + Cable loss (dB) – Pre-Amplifier gain (dB).

3.When the peak results are less than average limit, so not need to evaluate the average.

Standard:	FCC Part 15.407	Test Distance:	3 m
Test item:	Band edge		
Frequency:	5310 MHz		
Mode:	Mode 9		
Ant.Polar.:	Horizontal		

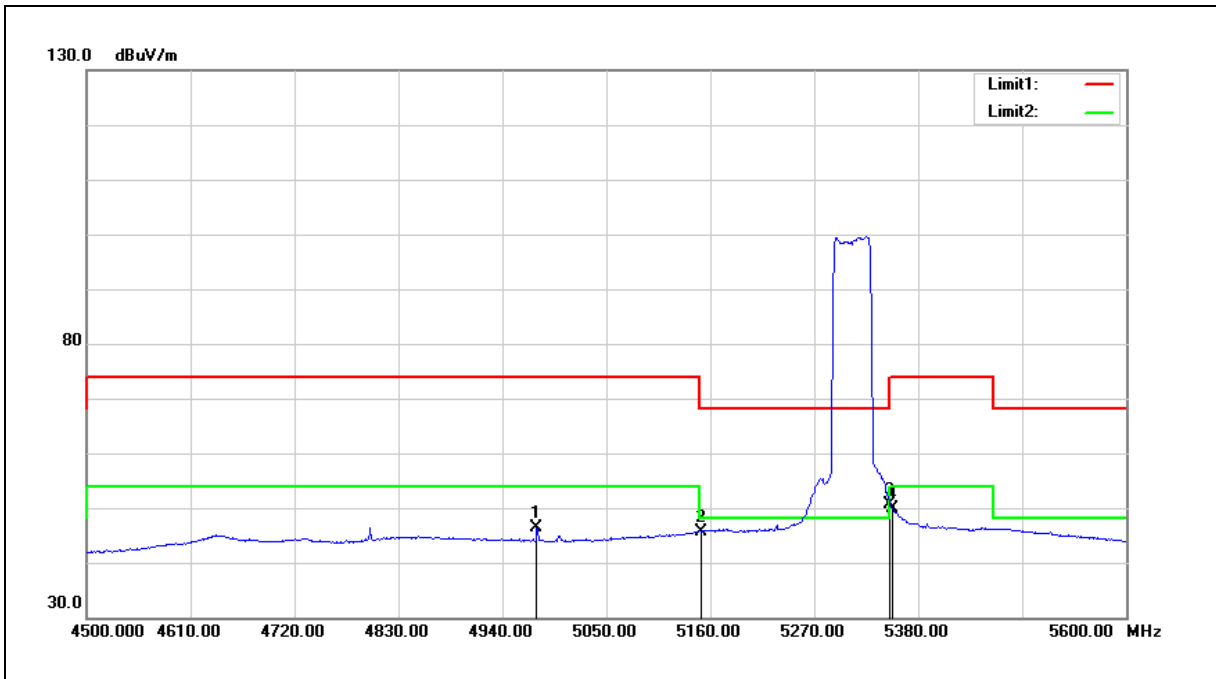

No.	Frequency (MHz)	Reading (dBuV)	Correct Factor (dB/m)	Result (dBuV/m)	Limit (dBuV/m)	Margin (dB)	Remark
1	4976.300	40.98	5.50	46.48	54.00	-7.52	AVG
2	5150.000	39.91	5.75	45.66	54.00	-8.34	AVG
3	5350.000	44.73	6.00	50.73	54.00	-3.27	AVG
4	5352.500	43.81	6.00	49.81	54.00	-4.19	AVG

Note:1.Result (dBuV/m) = Correct Factor (dB/m) + Reading(dBuV).

2.Correction factor (dB/m) = Antenna Factor (dB/m) + Cable loss (dB) – Pre-Amplifier gain (dB).

3.When the peak results are less than average limit, so not need to evaluate the average.

Standard:	FCC Part 15.407	Test Distance:	3 m
Test item:	Band edge		
Frequency:	5310 MHz		
Mode:	Mode 9		
Ant.Polar.:	Vertical		

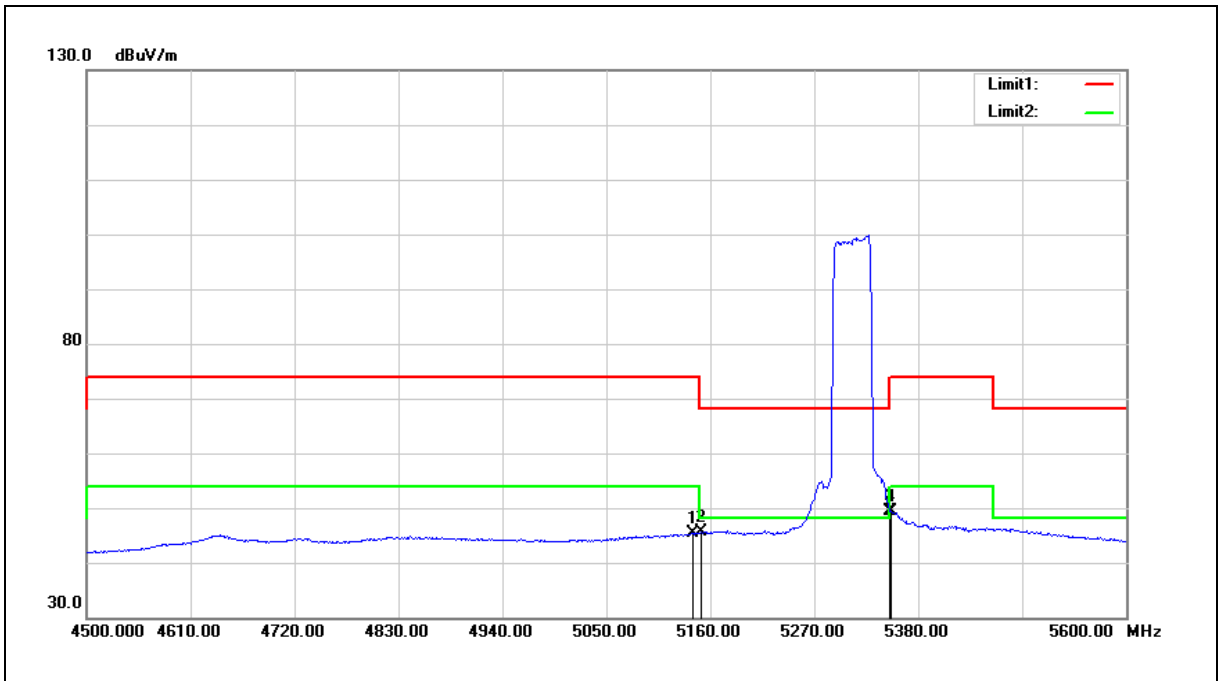

No.	Frequency (MHz)	Reading (dBuV)	Correct Factor (dB/m)	Result (dBuV/m)	Limit (dBuV/m)	Margin (dB)	Remark
1	5141.300	39.68	5.75	45.43	54.00	-8.57	AVG
2	5150.000	39.77	5.75	45.52	54.00	-8.48	AVG
3	5350.000	43.45	6.00	49.45	54.00	-4.55	AVG
4	5351.400	43.33	6.00	49.33	54.00	-4.67	AVG

Note:1.Result (dBuV/m) = Correct Factor (dB/m) + Reading(dBuV).

2.Correction factor (dB/m) = Antenna Factor (dB/m) + Cable loss (dB) – Pre-Amplifier gain (dB).

3.When the peak results are less than average limit, so not need to evaluate the average.

Standard:	FCC Part 15.407	Test Distance:	3 m
Test item:	Band edge		
Frequency:	5510 MHz		
Mode:	Mode 9		
Ant.Polar.:	Horizontal		

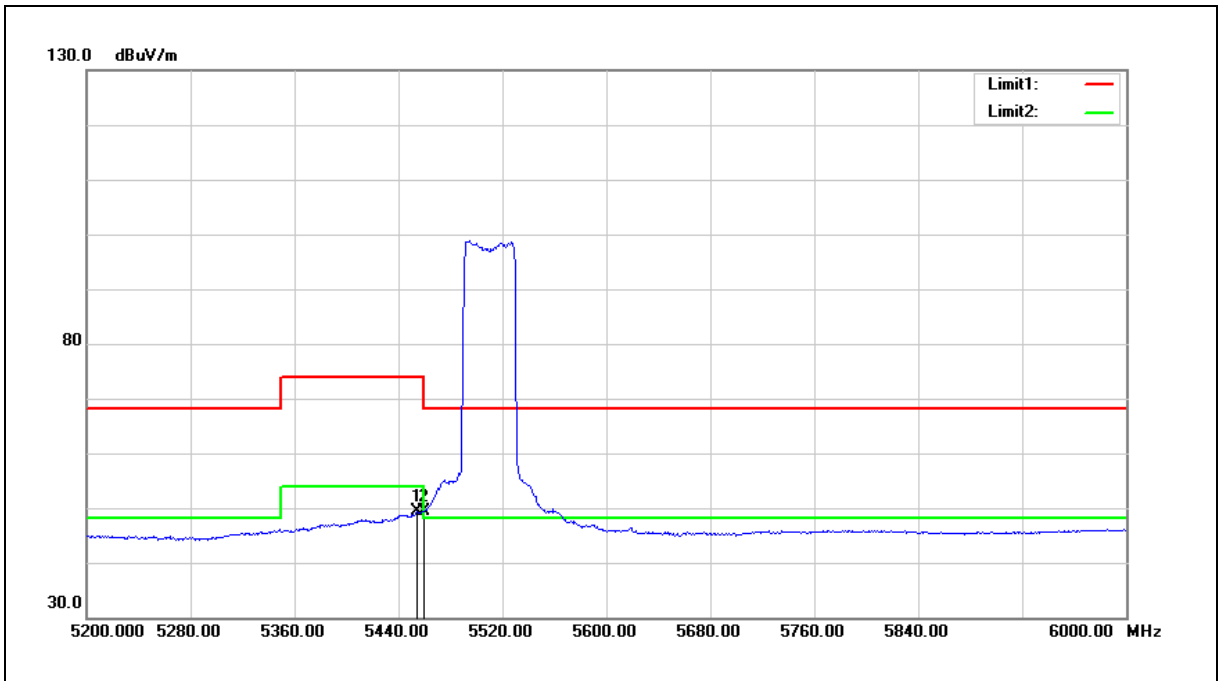

No.	Frequency (MHz)	Reading (dBuV)	Correct Factor (dB/m)	Result (dBuV/m)	Limit (dBuV/m)	Margin (dB)	Remark
1	5454.400	43.17	6.13	49.30	54.00	-4.70	AVG
2	5460.000	43.19	6.14	49.33	54.00	-4.67	AVG

Note:1.Result (dBuV/m) = Correct Factor (dB/m) + Reading(dBuV).

2.Correction factor (dB/m) = Antenna Factor (dB/m) + Cable loss (dB) – Pre-Amplifier gain (dB).

3.When the peak results are less than average limit, so not need to evaluate the average.

Standard:	FCC Part 15.407	Test Distance:	3 m
Test item:	Band edge		
Frequency:	5510 MHz		
Mode:	Mode 9		
Ant.Polar.:	Vertical		

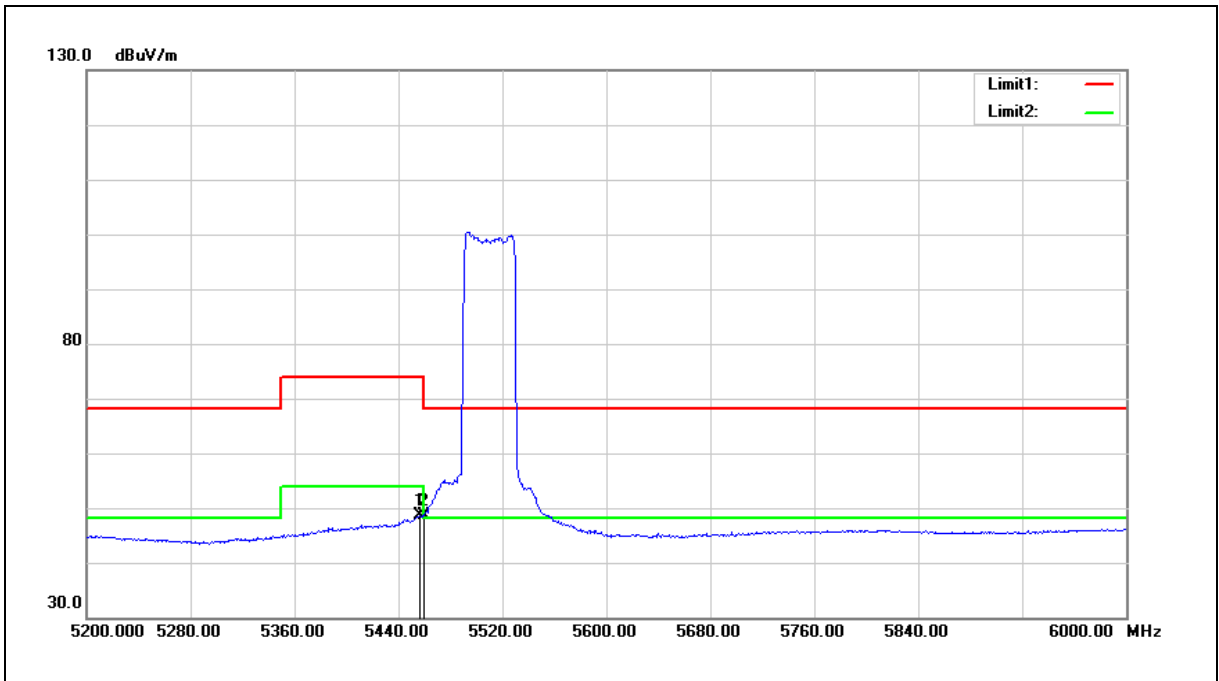

No.	Frequency (MHz)	Reading (dBuV)	Correct Factor (dB/m)	Result (dBuV/m)	Limit (dBuV/m)	Margin (dB)	Remark
1	5456.800	42.39	6.14	48.53	54.00	-5.47	AVG
2	5460.000	42.41	6.14	48.55	54.00	-5.45	AVG

- Note:1.Result (dBuV/m) = Correct Factor (dB/m) + Reading(dBuV).
- 2.Correction factor (dB/m) = Antenna Factor (dB/m) + Cable loss (dB) – Pre-Amplifier gain (dB).
- 3.When the peak results are less than average limit, so not need to evaluate the average.

Standard:	FCC Part 15.407	Test Distance:	3 m
Test item:	Band edge		
Frequency:	5550 MHz		
Mode:	Mode 9		
Ant.Polar.:	Horizontal		

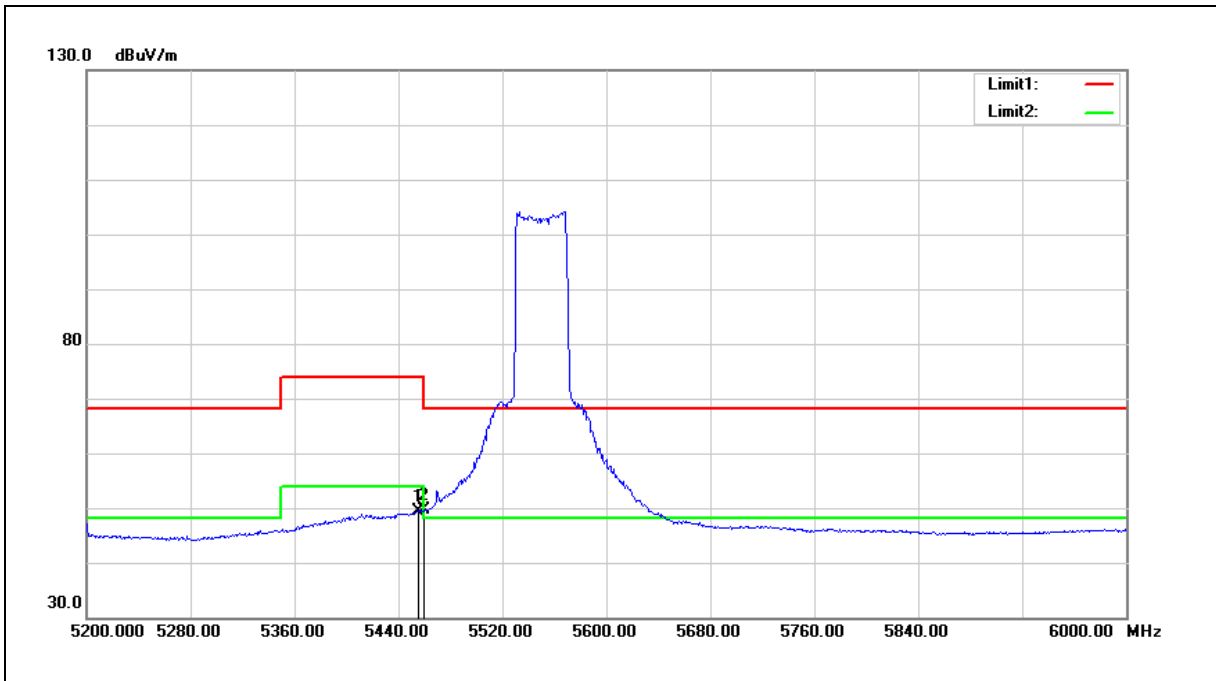

No.	Frequency (MHz)	Reading (dBuV)	Correct Factor (dB/m)	Result (dBuV/m)	Limit (dBuV/m)	Margin (dB)	Remark
1	5455.200	43.25	6.13	49.38	54.00	-4.62	AVG
2	5460.000	43.50	6.14	49.64	54.00	-4.36	AVG

Note:1.Result (dBuV/m) = Correct Factor (dB/m) + Reading(dBuV).

2.Correction factor (dB/m) = Antenna Factor (dB/m) + Cable loss (dB) – Pre-Amplifier gain (dB).

3.When the peak results are less than average limit, so not need to evaluate the average.

Standard:	FCC Part 15.407	Test Distance:	3 m
Test item:	Band edge		
Frequency:	5550 MHz		
Mode:	Mode 9		
Ant.Polar.:	Vertical		

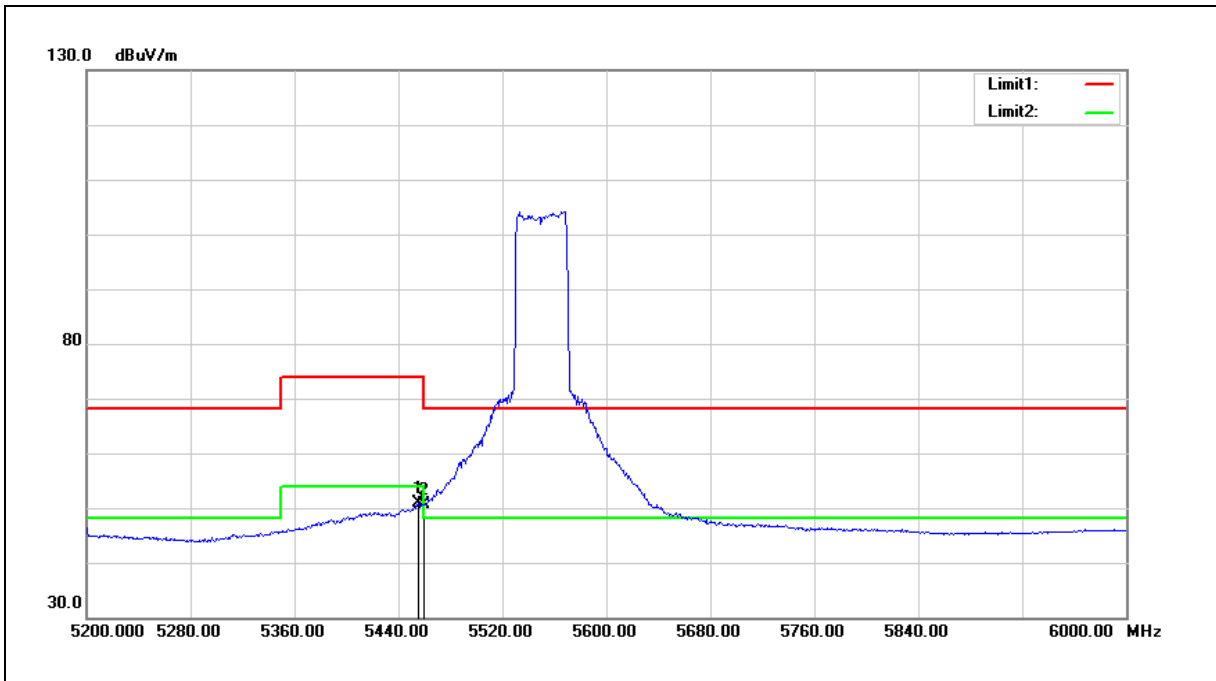

No.	Frequency (MHz)	Reading (dBuV)	Correct Factor (dB/m)	Result (dBuV/m)	Limit (dBuV/m)	Margin (dB)	Remark
1	5455.200	44.66	6.13	50.79	54.00	-3.21	AVG
2	5460.000	44.49	6.14	50.63	54.00	-3.37	AVG

- Note: 1. Result (dBuV/m) = Correct Factor (dB/m) + Reading (dBuV).
 2. Correction factor (dB/m) = Antenna Factor (dB/m) + Cable loss (dB) – Pre-Amplifier gain (dB).
 3. When the peak results are less than average limit, so not need to evaluate the average.

Standard:	FCC Part 15.407	Test Distance:	3 m
Test item:	Band edge		
Frequency:	5670 MHz		
Mode:	Mode 9		
Ant.Polar.:	Horizontal		

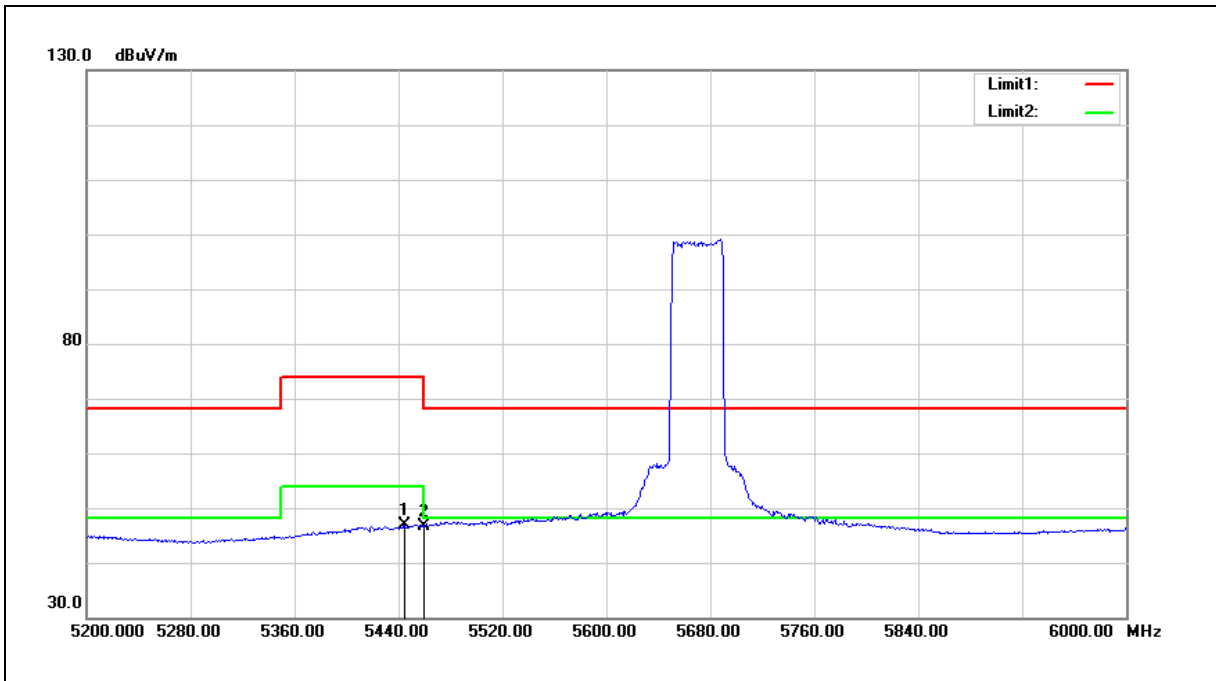

No.	Frequency (MHz)	Reading (dBuV)	Correct Factor (dB/m)	Result (dBuV/m)	Limit (dBuV/m)	Margin (dB)	Remark
1	5444.800	40.82	6.13	46.95	54.00	-7.05	AVG
2	5460.000	40.46	6.14	46.60	54.00	-7.40	AVG

Note:1.Result (dBuV/m) = Correct Factor (dB/m) + Reading(dBuV).

2.Correction factor (dB/m) = Antenna Factor (dB/m) + Cable loss (dB) – Pre-Amplifier gain (dB).

3.When the peak results are less than average limit, so not need to evaluate the average.

Standard:	FCC Part 15.407	Test Distance:	3 m
Test item:	Band edge		
Frequency:	5670 MHz		
Mode:	Mode 9		
Ant.Polar.:	Vertical		

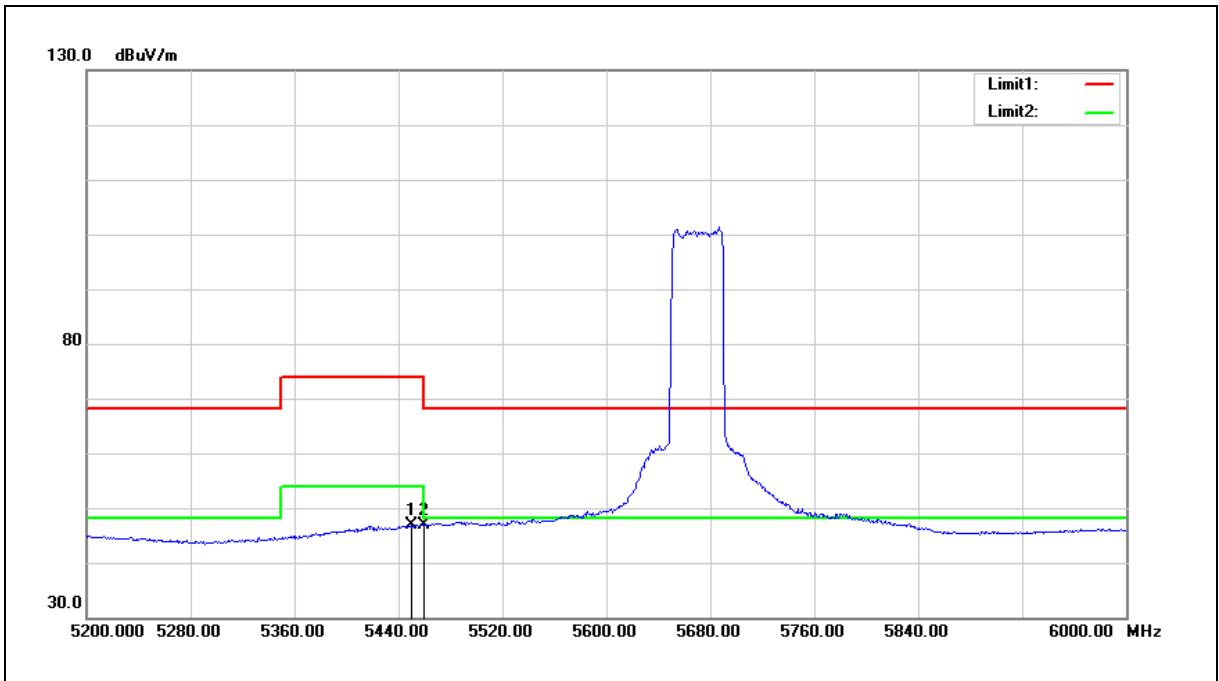

No.	Frequency (MHz)	Reading (dBuV)	Correct Factor (dB/m)	Result (dBuV/m)	Limit (dBuV/m)	Margin (dB)	Remark
1	5450.400	40.67	6.12	46.79	54.00	-7.21	AVG
2	5460.000	40.63	6.14	46.77	54.00	-7.23	AVG

Note:1.Result (dBuV/m) = Correct Factor (dB/m) + Reading(dBuV).

2.Correction factor (dB/m) = Antenna Factor (dB/m) + Cable loss (dB) – Pre-Amplifier gain (dB).

3.When the peak results are less than average limit, so not need to evaluate the average.

Standard:	FCC Part 15.407	Test Distance:	3 m
Test item:	Band edge		
Frequency:	5710 MHz		
Mode:	Mode 9		
Ant.Polar.:	Horizontal		

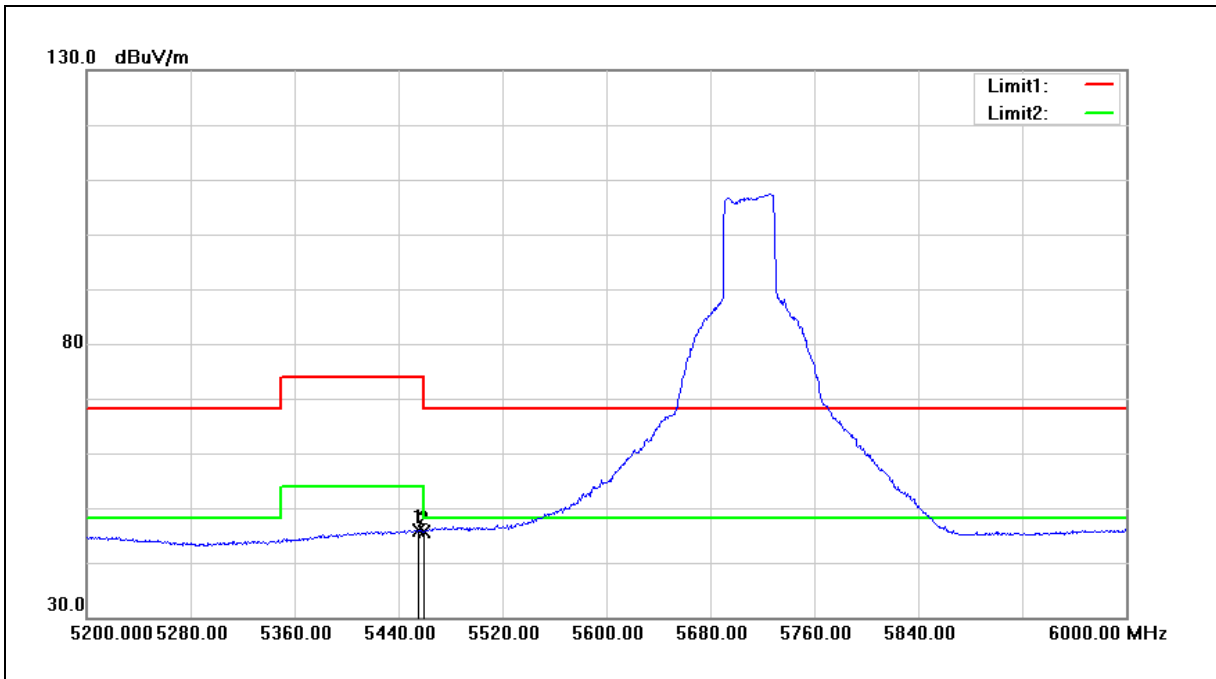

No.	Frequency (MHz)	Reading (dBuV)	Correct Factor (dB/m)	Result (dBuV/m)	Limit (dBuV/m)	Margin (dB)	Remark
1	5455.200	39.82	6.13	45.95	54.00	-8.05	AVG
2	5460.000	39.58	6.14	45.72	54.00	-8.28	AVG

- Note:1.Result (dBuV/m) = Correct Factor (dB/m) + Reading(dBuV).
- 2.Correction factor (dB/m) = Antenna Factor (dB/m) + Cable loss (dB) – Pre-Amplifier gain (dB).
- 3.When the peak results are less than average limit, so not need to evaluate the average.

Standard:	FCC Part 15.407	Test Distance:	3 m
Test item:	Band edge		
Frequency:	5710 MHz		
Mode:	Mode 9		
Ant.Polar.:	Vertical		

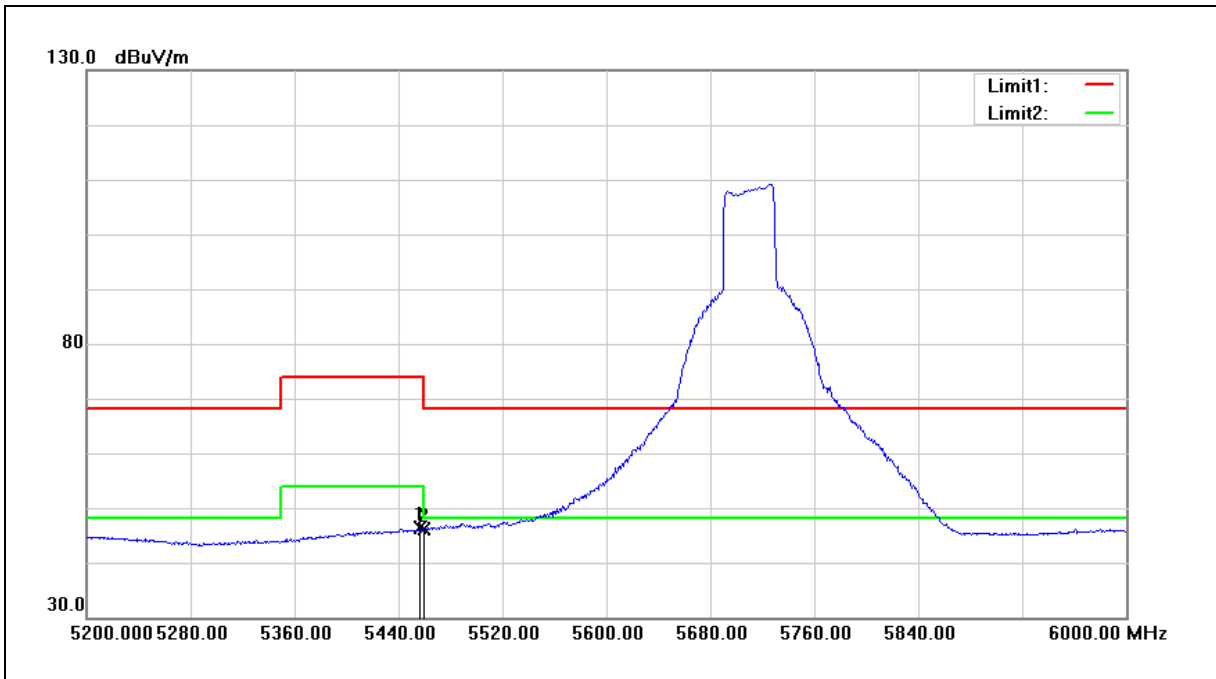

No.	Frequency (MHz)	Reading (dBuV)	Correct Factor (dB/m)	Result (dBuV/m)	Limit (dBuV/m)	Margin (dB)	Remark
1	5456.800	40.33	6.14	46.47	54.00	-7.53	AVG
2	5460.000	39.93	6.14	46.07	54.00	-7.93	AVG

- Note:1.Result (dBuV/m) = Correct Factor (dB/m) + Reading(dBuV).
- 2.Correction factor (dB/m) = Antenna Factor (dB/m) + Cable loss (dB) – Pre-Amplifier gain (dB).
- 3.When the peak results are less than average limit, so not need to evaluate the average.

Standard:	FCC Part 15.407	Test Distance:	3 m
Test item:	Band edge		
Frequency:	5210 MHz		
Mode:	Mode 10		
Ant.Polar.:	Horizontal		

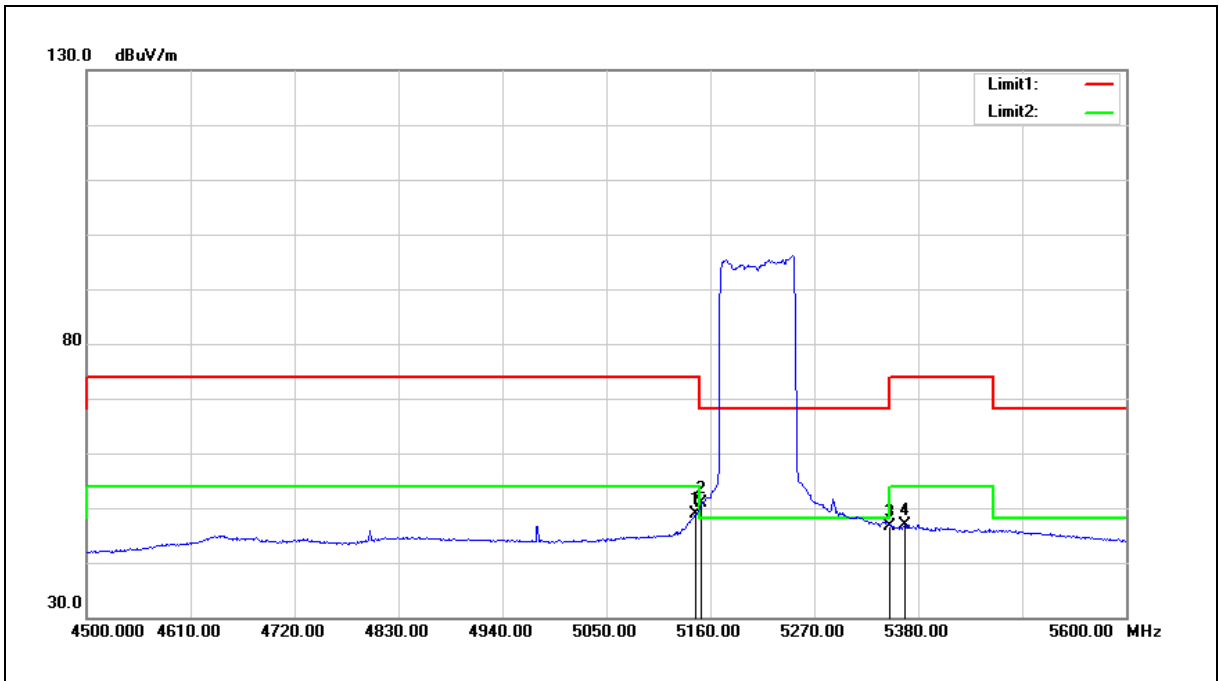

No.	Frequency (MHz)	Reading (dBuV)	Correct Factor (dB/m)	Result (dBuV/m)	Limit (dBuV/m)	Margin (dB)	Remark
1	5144.600	43.20	5.76	48.96	54.00	-5.04	AVG
2	5150.000	45.02	5.75	50.77	54.00	-3.23	AVG
3	5350.000	40.75	6.00	46.75	54.00	-7.25	AVG
4	5365.700	40.87	6.02	46.89	54.00	-7.11	AVG

Note:1.Result (dBuV/m) = Correct Factor (dB/m) + Reading(dBuV).

2.Correction factor (dB/m) = Antenna Factor (dB/m) + Cable loss (dB) – Pre-Amplifier gain (dB).

3.When the peak results are less than average limit, so not need to evaluate the average.

Standard:	FCC Part 15.407	Test Distance:	3 m
Test item:	Band edge		
Frequency:	5210 MHz		
Mode:	Mode 10		
Ant.Polar.:	Vertical		

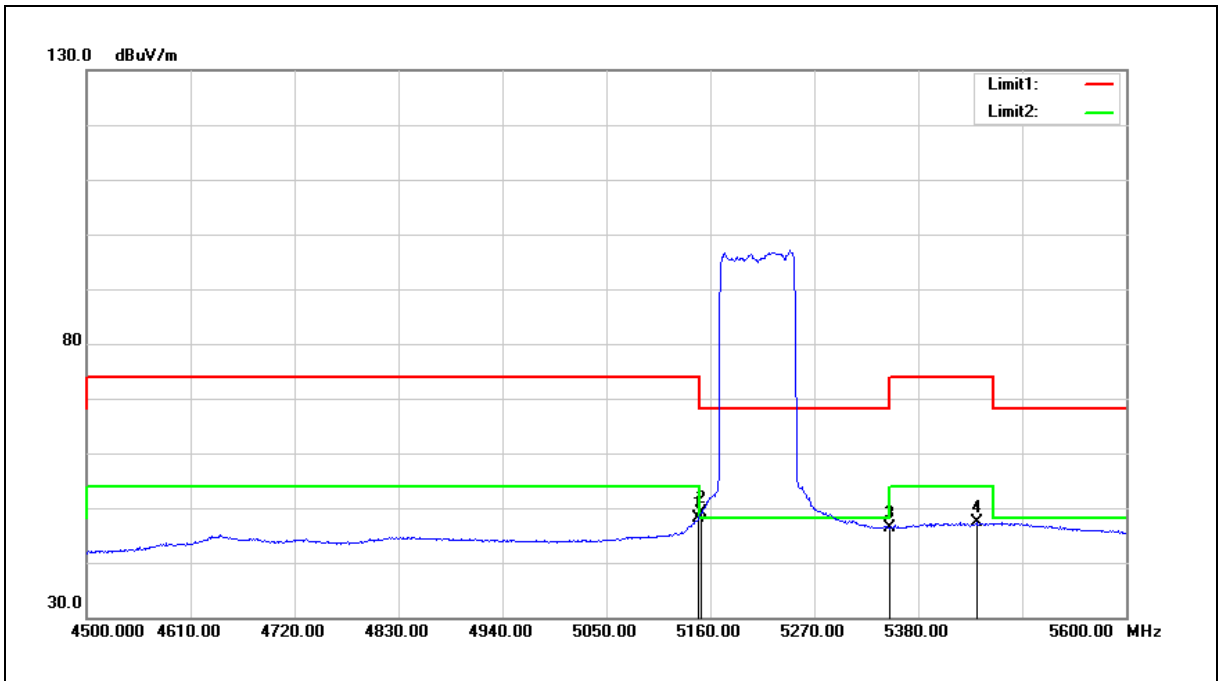

No.	Frequency (MHz)	Reading (dBuV)	Correct Factor (dB/m)	Result (dBuV/m)	Limit (dBuV/m)	Margin (dB)	Remark
1	5147.900	42.33	5.76	48.09	54.00	-5.91	AVG
2	5150.000	43.38	5.75	49.13	54.00	-4.87	AVG
3	5350.000	40.44	6.00	46.44	54.00	-7.56	AVG
4	5442.700	41.35	6.12	47.47	54.00	-6.53	AVG

Note:1.Result (dBuV/m) = Correct Factor (dB/m) + Reading(dBuV).

2.Correction factor (dB/m) = Antenna Factor (dB/m) + Cable loss (dB) – Pre-Amplifier gain (dB).

3.When the peak results are less than average limit, so not need to evaluate the average.

Standard:	FCC Part 15.407	Test Distance:	3 m
Test item:	Band edge		
Frequency:	5290 MHz		
Mode:	Mode 10		
Ant.Polar.:	Horizontal		

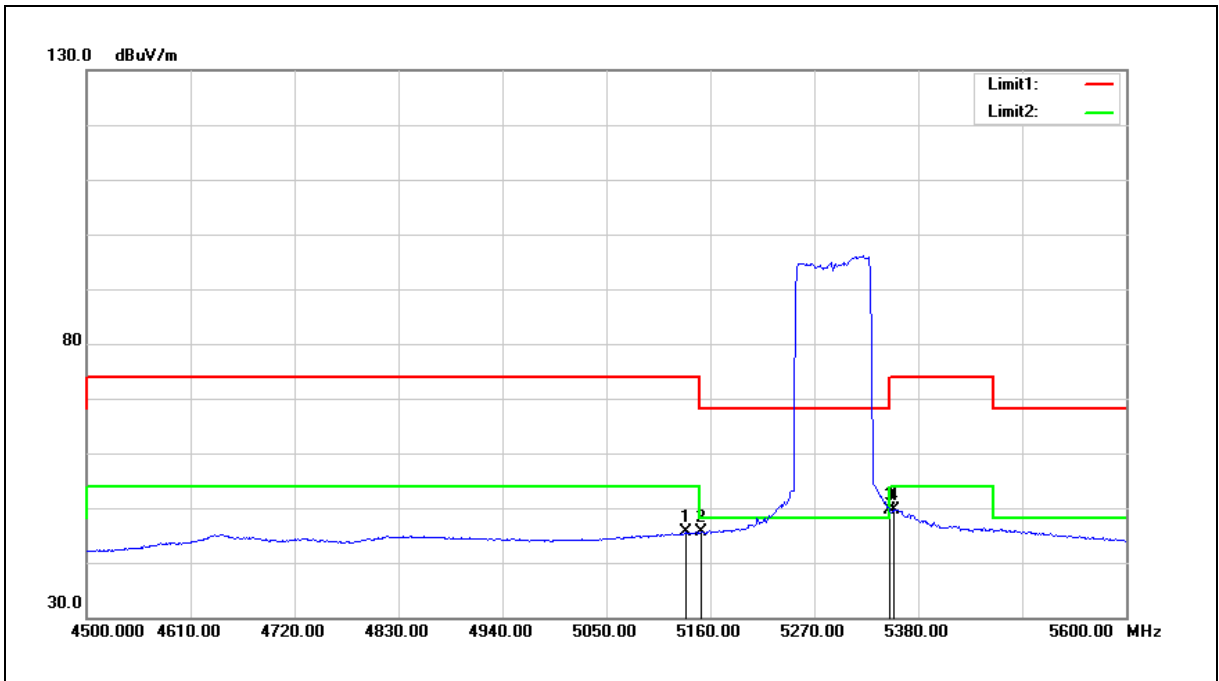

No.	Frequency (MHz)	Reading (dBuV)	Correct Factor (dB/m)	Result (dBuV/m)	Limit (dBuV/m)	Margin (dB)	Remark
1	5133.600	39.81	5.74	45.55	54.00	-8.45	AVG
2	5150.000	39.79	5.75	45.54	54.00	-8.46	AVG
3	5350.000	43.56	6.00	49.56	54.00	-4.44	AVG
4	5354.700	43.72	6.00	49.72	54.00	-4.28	AVG

Note:1.Result (dBuV/m) = Correct Factor (dB/m) + Reading(dBuV).

2.Correction factor (dB/m) = Antenna Factor (dB/m) + Cable loss (dB) – Pre-Amplifier gain (dB).

3.When the peak results are less than average limit, so not need to evaluate the average.

Standard:	FCC Part 15.407	Test Distance:	3 m
Test item:	Band edge		
Frequency:	5290 MHz		
Mode:	Mode 10		
Ant.Polar.:	Vertical		

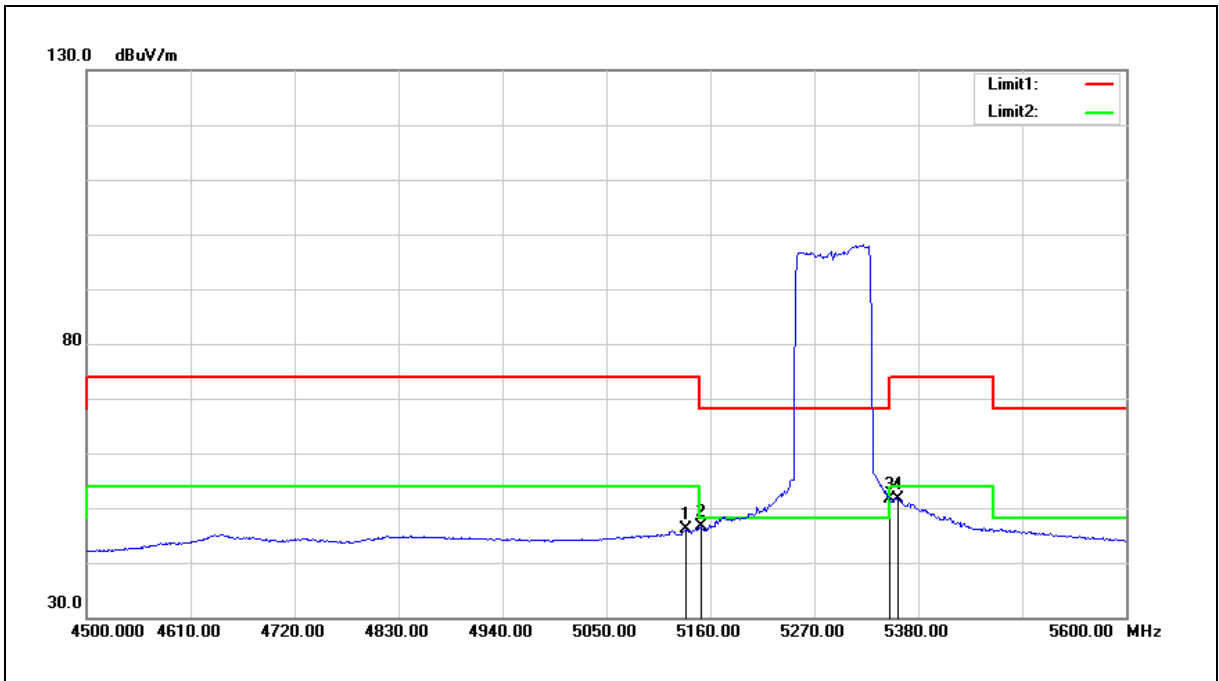

No.	Frequency (MHz)	Reading (dBuV)	Correct Factor (dB/m)	Result (dBuV/m)	Limit (dBuV/m)	Margin (dB)	Remark
1	5133.600	40.31	5.74	46.05	54.00	-7.95	AVG
2	5150.000	40.79	5.75	46.54	54.00	-7.46	AVG
3	5350.000	45.56	6.00	51.56	54.00	-2.44	AVG
4	5358.000	45.59	6.01	51.60	54.00	-2.40	AVG

Note:1.Result (dBuV/m) = Correct Factor (dB/m) + Reading(dBuV).

2.Correction factor (dB/m) = Antenna Factor (dB/m) + Cable loss (dB) – Pre-Amplifier gain (dB).

3.When the peak results are less than average limit, so not need to evaluate the average.

Standard:	FCC Part 15.407	Test Distance:	3 m
Test item:	Band edge		
Frequency:	5530 MHz		
Mode:	Mode 10		
Ant.Polar.:	Horizontal		

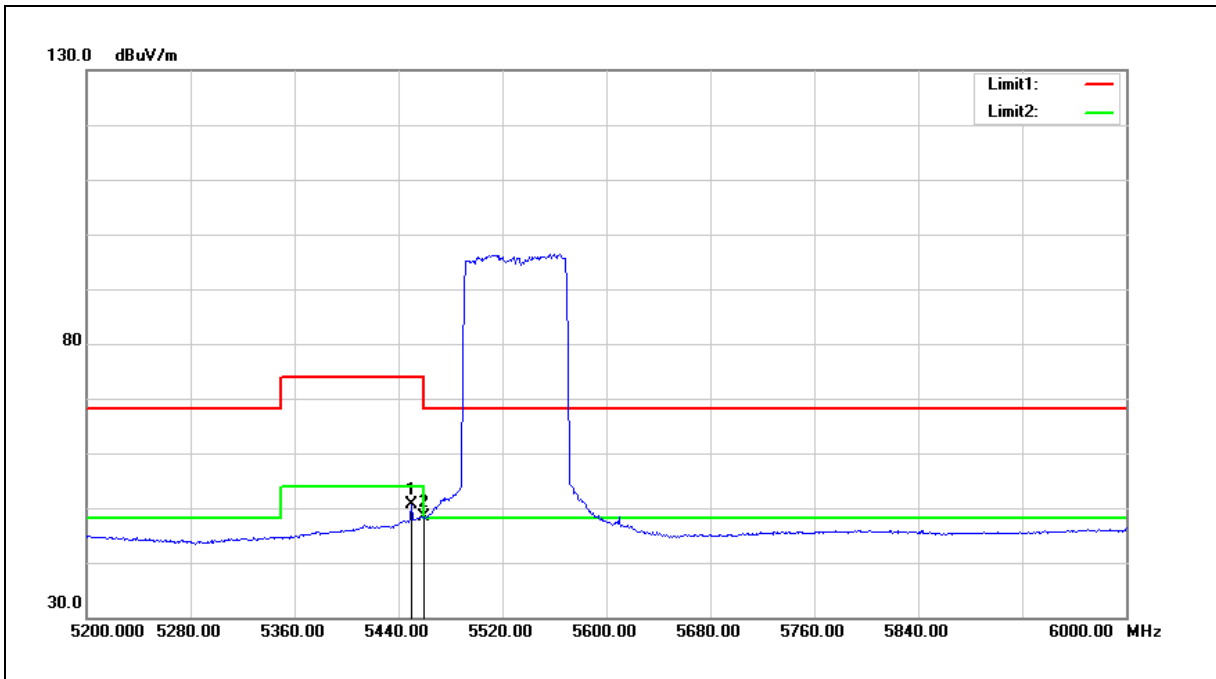

No.	Frequency (MHz)	Reading (dBuV)	Correct Factor (dB/m)	Result (dBuV/m)	Limit (dBuV/m)	Margin (dB)	Remark
1	5449.600	44.60	6.13	50.73	54.00	-3.27	AVG
2	5460.000	42.12	6.14	48.26	54.00	-5.74	AVG

Note:1.Result (dBuV/m) = Correct Factor (dB/m) + Reading(dBuV).

2.Correction factor (dB/m) = Antenna Factor (dB/m) + Cable loss (dB) – Pre-Amplifier gain (dB).

3.When the peak results are less than average limit, so not need to evaluate the average.

Standard:	FCC Part 15.407	Test Distance:	3 m
Test item:	Band edge		
Frequency:	5530 MHz		
Mode:	Mode 10		
Ant.Polar.:	Vertical		

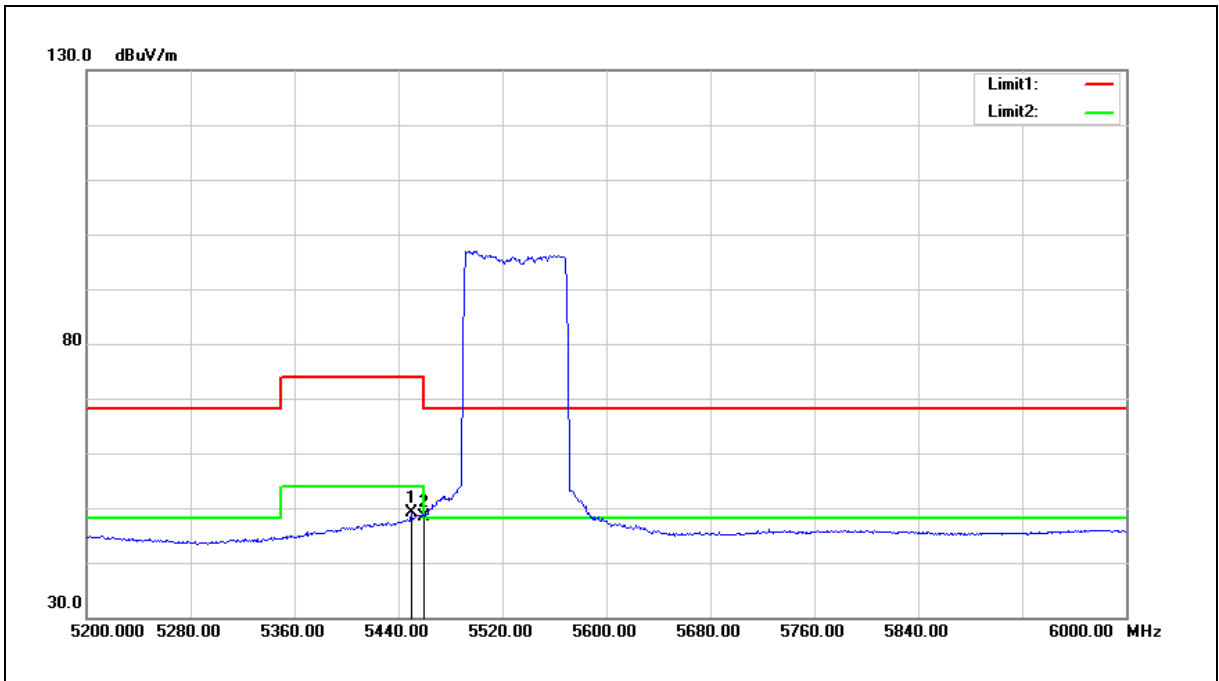

No.	Frequency (MHz)	Reading (dBuV)	Correct Factor (dB/m)	Result (dBuV/m)	Limit (dBuV/m)	Margin (dB)	Remark
1	5449.600	42.99	6.13	49.12	54.00	-4.88	AVG
2	5460.000	42.30	6.14	48.44	54.00	-5.56	AVG

Note:1.Result (dBuV/m) = Correct Factor (dB/m) + Reading(dBuV).

2.Correction factor (dB/m) = Antenna Factor (dB/m) + Cable loss (dB) – Pre-Amplifier gain (dB).

3.When the peak results are less than average limit, so not need to evaluate the average.

Standard:	FCC Part 15.407	Test Distance:	3 m
Test item:	Band edge		
Frequency:	5690 MHz		
Mode:	Mode 10		
Ant.Polar.:	Horizontal		

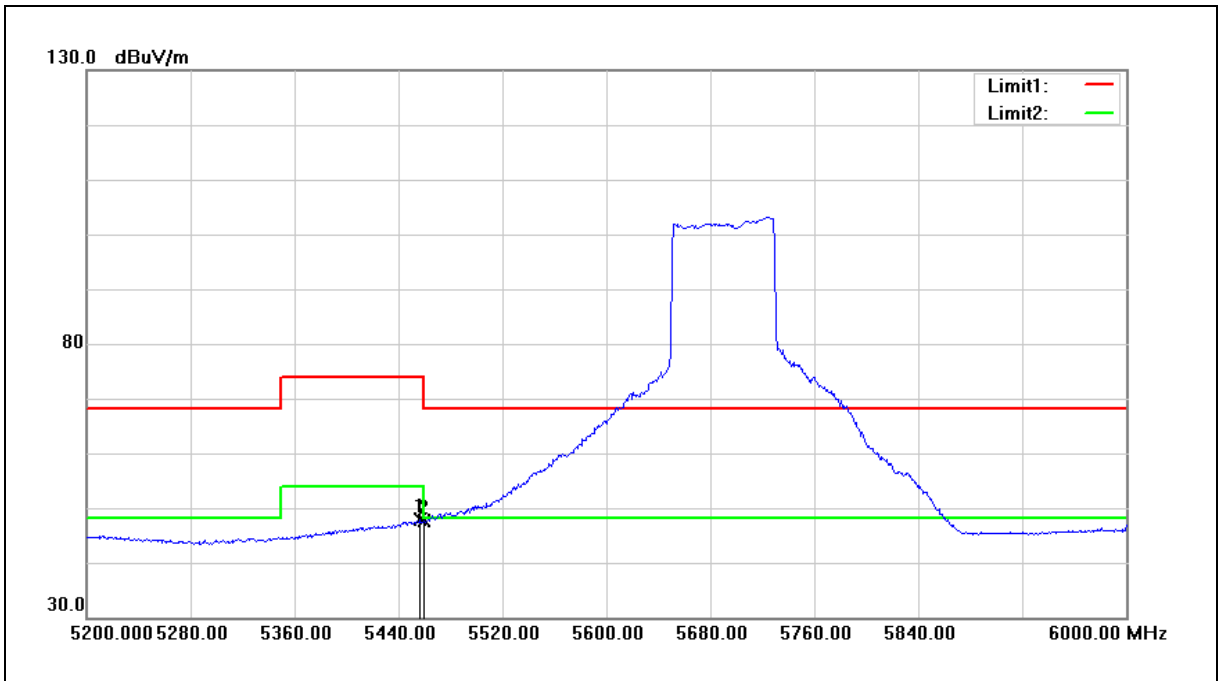

No.	Frequency (MHz)	Reading (dBuV)	Correct Factor (dB/m)	Result (dBuV/m)	Limit (dBuV/m)	Margin (dB)	Remark
1	5456.800	41.64	6.14	47.78	54.00	-6.22	AVG
2	5460.000	41.46	6.14	47.60	54.00	-6.40	AVG

Note:1.Result (dBuV/m) = Correct Factor (dB/m) + Reading(dBuV).

2.Correction factor (dB/m) = Antenna Factor (dB/m) + Cable loss (dB) – Pre-Amplifier gain (dB).

3.When the peak results are less than average limit, so not need to evaluate the average.

Standard:	FCC Part 15.407	Test Distance:	3 m
Test item:	Band edge		
Frequency:	5690 MHz		
Mode:	Mode 10		
Ant.Polar.:	Vertical		

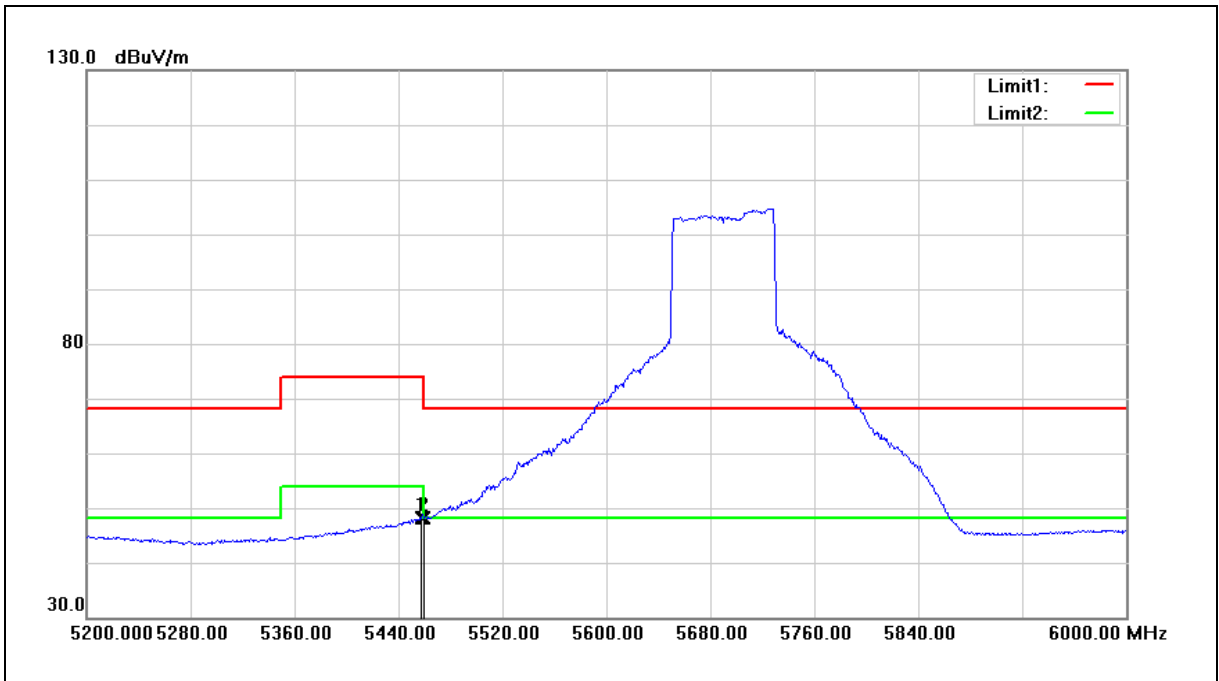

No.	Frequency (MHz)	Reading (dBuV)	Correct Factor (dB/m)	Result (dBuV/m)	Limit (dBuV/m)	Margin (dB)	Remark
1	5457.600	42.05	6.14	48.19	54.00	-5.81	AVG
2	5460.000	41.99	6.14	48.13	54.00	-5.87	AVG

Note:1.Result (dBuV/m) = Correct Factor (dB/m) + Reading(dBuV).

2.Correction factor (dB/m) = Antenna Factor (dB/m) + Cable loss (dB) – Pre-Amplifier gain (dB).

3.When the peak results are less than average limit, so not need to evaluate the average.

5.3. Conducted Test Results

Maximum Conducted Output Power Measurement

Test Mode	Frequency (MHz)	RF Power setting in Test Software				Test Software Version
		ANT-0	ANT-1	ANT-2	ANT-3	
Mode 2	5260	16	16	16	16	Putty
	5280	16	16	16	16	
	5320	17	17	17	17	
	5500	16	16	16	16	
	5560	16	16	16	16	
	5700	15	15	15	15	
	5720	16	16	16	16	
	5720	16	16	16	16	
Mode 3	5260	18	18	18	18	
	5280	18	18	18	18	
	5320	18	18	18	18	
	5500	17	17	17	17	
	5560	17	17	17	17	
	5700	17	17	17	17	
	5720	17	17	17	17	
	5720	17	17	17	17	
Mode 4	5270	16	16	16	16	
	5310	16	16	16	16	
	5510	16	16	16	16	
	5550	18	18	18	18	
	5670	19	19	19	19	
	5710	17	17	17	17	
	5710	17	17	17	17	

Test Mode	Frequency (MHz)	RF Power setting in Test Software				Test Software Version
		ANT-0	ANT-1	ANT-2	ANT-3	
Mode 5	5260	18	18	18	18	Putty
	5280	18	18	18	18	
	5320	18	18	18	18	
	5500	17	17	17	17	
	5560	17	17	17	17	
	5700	17	17	17	17	
	5720	17	17	17	17	
	5720	17	17	17	17	
Mode 6	5270	16	16	16	16	
	5310	16	16	16	16	
	5510	16	16	16	16	
	5550	18	18	18	18	
	5670	19	19	19	19	
	5710	17	17	17	17	
	5710	17	17	17	17	
Mode 7	5290	16	16	16	16	
	5530	16	16	16	16	
	5610	21	21	21	21	
	5690	19	19	19	19	
	5690	19	19	19	19	

Test Mode	Frequency (MHz)	RF Power setting in Test Software				Test Software Version
		ANT-0	ANT-1	ANT-2	ANT-3	
Mode 8	5180	19.00	19.00	19.00	19.00	Putty
	5200	23.00	23.00	23.00	23.00	
	5240	23.00	23.00	23.00	23.00	
	5260	18.00	18.00	18.00	18.00	
	5280	18.00	18.00	18.00	18.00	
	5320	18.00	18.00	18.00	18.00	
	5500	17.00	17.00	17.00	17.00	
	5560	17.00	17.00	17.00	17.00	
	5700	17.00	17.00	17.00	17.00	
	5720	17.00	17.00	17.00	17.00	
	5720	17.00	17.00	17.00	17.00	
	5745	23.00	23.00	23.00	23.00	
	5785	23.00	23.00	23.00	23.00	
	5825	23.00	23.00	23.00	23.00	
Mode 9	5190	15.00	15.00	15.00	15.00	
	5230	18.00	18.00	18.00	18.00	
	5270	16.00	16.00	16.00	16.00	
	5310	16.00	16.00	16.00	16.00	
	5510	16.00	16.00	16.00	16.00	
	5550	18.00	18.00	18.00	18.00	
	5670	19.00	19.00	19.00	19.00	
	5710	17.00	17.00	17.00	17.00	
	5710	17.00	17.00	17.00	17.00	
	5755	22.00	22.00	22.00	22.00	
	5795	23.00	23.00	23.00	23.00	
Mode 10	5210	16.00	16.00	16.00	16.00	
	5290	16.00	16.00	16.00	16.00	
	5530	16.00	16.00	16.00	16.00	
	5610	21.00	21.00	21.00	21.00	
	5690	19.00	19.00	19.00	19.00	
	5690	19.00	19.00	19.00	19.00	
	5775	22.00	22.00	22.00	22.00	

Beamforming on

Test Mode	Frequency (MHz)	RF Power setting in Test Software				Test Software Version
		ANT-0	ANT-1	ANT-2	ANT-3	
Mode 3	5260	18	18	18	18	Putty
	5280	18	18	18	18	
	5320	18	18	18	18	
	5500	17	17	17	17	
	5560	17	17	17	17	
	5700	17	17	17	17	
	5720	17	17	17	17	
	5720	17	17	17	17	
Mode 4	5270	16	16	16	16	
	5310	16	16	16	16	
	5510	16	16	16	16	
	5550	18	18	18	18	
	5670	19	19	19	19	
	5710	17	17	17	17	
	5710	17	17	17	17	
	5710	17	17	17	17	
Mode 5	5260	18	18	18	18	
	5280	18	18	18	18	
	5320	18	18	18	18	
	5500	17	17	17	17	
	5560	17	17	17	17	
	5700	17	17	17	17	
	5720	17	17	17	17	
	5720	17	17	17	17	
Mode 6	5270	16	16	16	16	
	5310	16	16	16	16	
	5510	16	16	16	16	
	5550	18	18	18	18	
	5670	19	19	19	19	
	5710	17	17	17	17	
	5710	17	17	17	17	
	5710	17	17	17	17	
Mode 7	5290	16	16	16	16	
	5530	16	16	16	16	
	5610	21	21	21	21	
	5690	19	19	19	19	
	5690	19	19	19	19	

Test Mode	Frequency (MHz)	RF Power setting in Test Software				Test Software Version
		ANT-0	ANT-1	ANT-2	ANT-3	
Mode 8	5260	18	18	18	18	Putty
	5280	18	18	18	18	
	5320	18	18	18	18	
	5500	17	17	17	17	
	5560	17	17	17	17	
	5700	17	17	17	17	
	5720	17	17	17	17	
	5720	17	17	17	17	
Mode 9	5270	16	16	16	16	
	5310	16	16	16	16	
	5510	16	16	16	16	
	5550	18	18	18	18	
	5670	19	19	19	19	
	5710	17	17	17	17	
	5710	17	17	17	17	
Mode 10	5290	16	16	16	16	
	5530	16	16	16	16	
	5610	21	21	21	21	
	5690	19	19	19	19	
	5690	19	19	19	19	

Maximum Conducted Output Power and Transmit power control Measurement

Test Mode	Data Rate	Frequency (MHz)	Max. Output Power										Limit (dBm)
			ANT-0		ANT-1		ANT-2		ANT-3		ANT-0+1+2+3		
			(dBm)	(W)	(dBm)	(W)	(dBm)	(W)	(dBm)	(W)	(dBm)	(W)	
Mode 2	6 M	5260	15.61	0.036	14.41	0.028	15.15	0.033	14.57	0.029	20.98	0.125	≤ 24.00
		5280	15.60	0.036	14.33	0.027	15.15	0.033	14.68	0.029	20.99	0.126	≤ 24.00
		5320	13.66	0.023	14.31	0.027	13.95	0.025	14.85	0.031	20.24	0.106	≤ 24.00
		5500	12.66	0.018	13.55	0.023	12.58	0.018	13.93	0.025	19.24	0.084	≤ 23.14
		5560	12.39	0.017	13.31	0.021	12.25	0.017	13.48	0.022	18.91	0.078	≤ 23.14
		5700	12.09	0.016	12.82	0.019	11.78	0.015	13.41	0.022	18.59	0.072	≤ 23.14
		5720	13.92	0.025	14.82	0.030	13.63	0.023	15.49	0.035	20.55	0.114	≤ 23.14
		5720	8.00	0.006	8.54	0.007	8.16	0.007	9.22	0.008	14.52	0.028	≤ 30.00
Mode 3	26 M	5260	14.42	0.028	14.27	0.027	14.39	0.027	14.45	0.028	20.40	0.110	≤ 24.00
		5280	14.62	0.029	14.71	0.030	14.86	0.031	14.77	0.030	20.76	0.119	≤ 24.00
		5320	14.01	0.025	14.98	0.031	15.03	0.032	14.72	0.030	20.72	0.118	≤ 24.00
		5500	13.85	0.024	13.55	0.023	12.97	0.020	13.48	0.022	19.49	0.089	≤ 24.00
		5560	13.55	0.023	13.85	0.024	13.47	0.022	14.01	0.025	19.75	0.094	≤ 24.00
		5700	13.88	0.024	14.03	0.025	12.91	0.020	13.75	0.024	19.68	0.093	≤ 24.00
		5720	14.61	0.029	14.96	0.031	14.16	0.026	15.17	0.033	20.76	0.119	≤ 24.00
		5720	9.69	0.009	10.06	0.010	9.41	0.009	10.23	0.011	15.88	0.039	≤ 30.00
Mode 4	54 M	5270	14.02	0.025	13.25	0.021	13.41	0.022	13.87	0.024	19.67	0.093	≤ 24.00
		5310	13.99	0.025	13.41	0.022	13.79	0.024	14.17	0.026	19.87	0.097	≤ 24.00
		5510	14.98	0.031	14.30	0.027	14.81	0.030	14.89	0.031	20.77	0.119	≤ 24.00
		5550	15.95	0.039	15.73	0.037	15.44	0.035	15.98	0.040	21.80	0.151	≤ 24.00
		5670	16.31	0.043	16.32	0.043	15.57	0.036	15.85	0.038	22.04	0.160	≤ 24.00
		5710	17.22	0.053	17.19	0.052	16.27	0.042	17.34	0.054	23.04	0.201	≤ 24.00
		5710	8.27	0.007	8.32	0.007	7.34	0.005	8.24	0.007	14.08	0.026	≤ 30.00

Note: The relevant measured result has the offset with cable loss already.

Test Mode	Data Rate	Frequency (MHz)	Max. Output Power										Limit (dBm)
			ANT-0		ANT-1		ANT-2		ANT-3		ANT-0+1+2+3		
			(dBm)	(W)	(dBm)	(W)	(dBm)	(W)	(dBm)	(W)	(dBm)	(W)	
Mode 5	26 M	5260	14.22	0.026	14.19	0.026	14.33	0.027	14.58	0.029	20.35	0.108	≤ 24.00
		5280	14.52	0.028	14.61	0.029	14.77	0.030	14.62	0.029	20.65	0.116	≤ 24.00
		5320	13.77	0.024	14.72	0.030	14.99	0.032	14.65	0.029	20.58	0.114	≤ 24.00
		5500	13.62	0.023	13.27	0.021	12.73	0.019	13.48	0.022	19.31	0.085	≤ 24.00
		5560	13.33	0.022	13.58	0.023	13.27	0.021	13.75	0.024	19.51	0.089	≤ 24.00
		5700	13.77	0.024	13.82	0.024	12.69	0.019	13.66	0.023	19.53	0.090	≤ 24.00
		5720	14.64	0.029	15.01	0.032	14.27	0.027	15.09	0.032	20.79	0.120	≤ 24.00
		5720	9.81	0.010	15.01	0.032	14.27	0.027	15.09	0.032	20.02	0.100	≤ 30.00
Mode 6	54 M	5270	13.76	0.024	13.31	0.021	13.74	0.024	13.54	0.023	19.61	0.091	≤ 24.00
		5310	13.99	0.025	13.41	0.022	13.79	0.024	14.17	0.026	19.87	0.097	≤ 24.00
		5510	14.98	0.031	14.30	0.027	14.81	0.030	14.89	0.031	20.77	0.119	≤ 24.00
		5550	15.72	0.037	15.51	0.036	15.32	0.034	15.65	0.037	21.57	0.144	≤ 24.00
		5670	15.95	0.039	15.98	0.040	15.42	0.035	15.63	0.037	21.77	0.150	≤ 24.00
		5710	17.24	0.053	17.23	0.053	16.35	0.043	17.40	0.055	23.09	0.204	≤ 24.00
		5710	8.35	0.007	8.47	0.007	7.52	0.006	8.37	0.007	14.21	0.026	≤ 30.00
Mode 7	117.2 M	5290	12.98	0.020	12.79	0.019	12.89	0.019	13.11	0.020	18.96	0.079	≤ 24.00
		5530	14.00	0.025	13.78	0.024	14.44	0.028	14.23	0.026	20.14	0.103	≤ 24.00
		5610	15.19	0.033	14.65	0.029	15.57	0.036	15.11	0.032	21.16	0.131	≤ 24.00
		5690	17.25	0.053	17.59	0.057	16.94	0.049	17.48	0.056	23.34	0.216	≤ 24.00
		5690	4.57	0.003	4.98	0.003	4.34	0.003	5.14	0.003	10.79	0.012	≤ 30.00

Note: The relevant measured result has the offset with cable loss already.

Test Mode	Data Rate	Frequency (MHz)	Max. Output Power										Limit (dBm)
			ANT-0		ANT-1		ANT-2		ANT-3		ANT-0+1+2+3		
			(dBm)	(W)	(dBm)	(W)	(dBm)	(W)	(dBm)	(W)	(dBm)	(W)	
Mode 8	MCS0	5260	14.51	0.028	14.38	0.027	14.53	0.028	14.61	0.029	20.53	0.113	≤ 24.00
		5280	14.75	0.030	14.83	0.030	15.01	0.032	14.89	0.031	20.89	0.123	≤ 24.00
		5320	14.05	0.025	15.03	0.032	15.18	0.033	14.81	0.030	20.81	0.121	≤ 24.00
		5500	13.96	0.025	13.58	0.023	13.05	0.020	13.62	0.023	19.59	0.091	≤ 24.00
		5560	13.68	0.023	13.91	0.025	13.59	0.023	14.03	0.025	19.83	0.096	≤ 24.00
		5700	13.95	0.025	14.07	0.026	13.02	0.020	13.98	0.025	19.80	0.095	≤ 24.00
		5720	14.75	0.030	15.07	0.032	14.40	0.028	15.17	0.033	20.88	0.122	≤ 24.00
		5720	9.88	0.010	10.21	0.010	9.59	0.009	10.38	0.011	16.05	0.040	≤ 30.00
Mode 9	MCS0	5270	14.23	0.026	13.78	0.024	14.21	0.026	14.01	0.025	20.08	0.102	≤ 24.00
		5310	14.46	0.028	13.88	0.024	14.26	0.027	14.64	0.029	20.34	0.108	≤ 24.00
		5510	15.45	0.035	14.77	0.030	15.28	0.034	15.36	0.034	21.24	0.133	≤ 24.00
		5550	16.03	0.040	15.88	0.039	15.48	0.035	16.03	0.040	21.88	0.154	≤ 24.00
		5670	16.38	0.043	16.43	0.044	15.66	0.037	15.98	0.040	22.14	0.164	≤ 24.00
		5710	17.42	0.055	17.44	0.055	16.60	0.046	17.44	0.055	23.26	0.212	≤ 24.00
		5710	8.40	0.007	8.57	0.007	7.69	0.006	8.53	0.007	14.33	0.027	≤ 30.00
Mode 10	MCS0	5290	13.21	0.021	13.02	0.020	13.12	0.021	13.34	0.022	19.19	0.083	≤ 24.00
		5530	14.23	0.026	14.01	0.025	14.67	0.029	14.46	0.028	20.37	0.109	≤ 24.00
		5610	17.82	0.061	17.65	0.058	17.18	0.052	17.25	0.053	23.50	0.224	≤ 24.00
		5690	17.40	0.055	17.69	0.059	17.06	0.051	17.67	0.058	23.48	0.223	≤ 24.00
		5690	4.71	0.003	5.21	0.003	4.44	0.003	5.25	0.003	10.94	0.012	≤ 30.00

Note: The relevant measured result has the offset with cable loss already.

Test Mode	Data Rate	Frequency (MHz)	RU	RU Number	Max. Output Power						Limit (dBm)
					ANT-0		ANT-1		ANT-2		
					(dBm)	(W)	(dBm)	(W)	(dBm)	(W)	
Mode 8	MCS0	5180	26	1	6.52	0.004	6.63	0.005	6.26	0.004	≤ 30.00
		5200	26	1	10.91	0.012	10.95	0.012	10.81	0.012	≤ 30.00
		5240	26	9	11.10	0.013	10.85	0.012	10.45	0.011	≤ 30.00
		5260	26	1	5.61	0.004	5.93	0.004	5.79	0.004	≤ 24.00
		5280	26	1	5.62	0.004	6.18	0.004	5.92	0.004	≤ 24.00
		5320	26	9	5.95	0.004	6.08	0.004	5.81	0.004	≤ 24.00
		5500	26	1	5.52	0.004	5.89	0.004	5.84	0.004	≤ 24.00
		5560	26	1	5.45	0.004	6.06	0.004	5.65	0.004	≤ 24.00
		5700	26	9	6.38	0.004	6.35	0.004	5.75	0.004	≤ 24.00
		5720	242	1	6.57	0.005	6.53	0.004	5.96	0.004	≤ 24.00
		5720	242	1	1.34	0.001	1.41	0.001	0.84	0.001	≤ 30.00
		5745	26	1	12.45	0.018	12.56	0.018	12.74	0.019	≤ 30.00
		5785	26	1	12.49	0.018	12.46	0.018	12.65	0.018	≤ 30.00
		5825	26	9	10.15	0.010	11.56	0.014	11.05	0.013	≤ 30.00
Mode 9	MCS0	5190	26	1	1.36	0.001	1.55	0.001	1.36	0.001	≤ 30.00
		5230	26	18	5.05	0.003	5.06	0.003	5.22	0.003	≤ 30.00
		5270	26	1	2.73	0.002	2.92	0.002	2.54	0.002	≤ 24.00
		5310	26	18	3.05	0.002	3.06	0.002	3.03	0.002	≤ 24.00
		5510	26	1	3.96	0.002	4.38	0.003	3.83	0.002	≤ 24.00
		5550	26	1	6.22	0.004	5.96	0.004	5.75	0.004	≤ 24.00
		5670	26	18	6.38	0.004	6.55	0.005	6.67	0.005	≤ 24.00
		5710	484	1	6.53	0.004	6.78	0.005	6.80	0.005	≤ 24.00
		5710	484	1	-2.31	0.001	-2.17	0.001	-2.14	0.001	≤ 30.00
		5755	26	1	10.26	0.011	10.62	0.012	9.76	0.009	≤ 30.00
5795	26	18	9.62	0.009	10.95	0.012	9.33	0.009	≤ 30.00		
Mode 10	MCS0	5210	26	1	0.02	0.001	-0.10	0.001	-0.21	0.001	≤ 30.00
		5290	26	37	0.65	0.001	0.41	0.001	0.34	0.001	≤ 24.00
		5530	26	1	1.25	0.001	1.66	0.001	0.75	0.001	≤ 24.00
		5610	26	37	5.75	0.004	5.93	0.004	5.63	0.004	≤ 24.00
		5690	968	1	5.83	0.004	5.98	0.004	5.70	0.004	≤ 24.00
		5690	968	1	-6.86	0.000	-6.50	0.000	-6.93	0.000	≤ 30.00
		5775	26	1	6.98	0.005	7.25	0.005	7.03	0.005	≤ 30.00

Note: The relevant measured result has the offset with cable loss already.

Test Mode	Data Rate	Frequency (MHz)	RU	RU Number	Max. Output Power				Limit (dBm)
					ANT-3		ANT-0+1+2+3		
					(dBm)	(W)	(dBm)		
Mode 8	MCS0	5180	26	1	6.61	0.005	12.53	0.018	≤ 30.00
		5200	26	1	11.23	0.013	17.00	0.050	≤ 30.00
		5240	26	9	11.39	0.014	16.98	0.050	≤ 30.00
		5260	26	1	6.21	0.004	11.91	0.016	≤ 24.00
		5280	26	1	6.25	0.004	12.02	0.016	≤ 24.00
		5320	26	9	6.33	0.004	12.07	0.016	≤ 24.00
		5500	26	1	6.12	0.004	11.87	0.015	≤ 24.00
		5560	26	1	5.89	0.004	11.79	0.015	≤ 24.00
		5700	26	9	6.13	0.004	12.18	0.017	≤ 24.00
		5720	242	1	6.36	0.004	12.38	0.017	≤ 24.00
		5720	242	1	1.26	0.001	7.24	0.005	≤ 30.00
		5745	26	1	13.01	0.020	18.72	0.074	≤ 30.00
		5785	26	1	12.83	0.019	18.63	0.073	≤ 30.00
		5825	26	9	11.91	0.016	17.24	0.053	≤ 30.00
Mode 9	MCS0	5190	26	1	1.81	0.002	7.54	0.006	≤ 30.00
		5230	26	18	5.23	0.003	11.16	0.013	≤ 30.00
		5270	26	1	2.75	0.002	8.76	0.008	≤ 24.00
		5310	26	18	3.15	0.002	9.09	0.008	≤ 24.00
		5510	26	1	4.25	0.003	10.13	0.010	≤ 24.00
		5550	26	1	5.98	0.004	12.00	0.016	≤ 24.00
		5670	26	18	6.36	0.004	12.51	0.018	≤ 24.00
		5710	484	1	6.64	0.005	12.71	0.019	≤ 24.00
		5710	484	1	-2.18	0.001	3.82	0.002	≤ 30.00
		5755	26	1	10.81	0.012	16.40	0.044	≤ 30.00
5795	26	18	9.81	0.010	15.99	0.040	≤ 30.00		
Mode 10	MCS0	5210	26	1	0.11	0.001	5.98	0.004	≤ 30.00
		5290	26	37	0.68	0.001	6.54	0.005	≤ 24.00
		5530	26	1	1.56	0.001	7.34	0.005	≤ 24.00
		5610	26	37	5.74	0.004	11.78	0.015	≤ 24.00
		5690	968	1	5.81	0.004	11.85	0.015	≤ 24.00
		5690	968	1	-6.61	0.000	-0.70	0.001	≤ 30.00
		5775	26	1	8.59	0.007	13.54	0.023	≤ 30.00

Note: The relevant measured result has the offset with cable loss already.

Beamforming on

Test Mode	Data Rate	Frequency (MHz)	Max. Output Power										Limit (dBm)
			ANT-0		ANT-1		ANT-2		ANT-3		ANT-0+1+2+3		
			(dBm)	(W)	(dBm)	(W)	(dBm)	(W)	(dBm)	(W)	(dBm)	(W)	
Mode 3	26 M	5260	14.41	0.028	14.18	0.026	14.34	0.027	14.42	0.028	20.36	0.109	≤ 24.00
		5280	14.60	0.029	14.67	0.029	14.82	0.030	14.67	0.029	20.71	0.118	≤ 24.00
		5320	13.99	0.025	14.95	0.031	14.94	0.031	14.70	0.029	20.68	0.117	≤ 24.00
		5500	13.84	0.024	13.49	0.022	12.95	0.020	13.45	0.022	19.46	0.088	≤ 24.00
		5560	13.54	0.023	13.80	0.024	13.44	0.022	13.94	0.025	19.71	0.094	≤ 24.00
		5700	13.85	0.024	14.01	0.025	12.84	0.019	13.66	0.023	19.63	0.092	≤ 24.00
		5720	14.56	0.029	14.81	0.030	14.03	0.025	15.06	0.032	20.65	0.116	≤ 24.00
		5720	9.62	0.009	9.97	0.010	9.26	0.008	10.20	0.010	15.80	0.038	≤ 30.00
Mode 4	54 M	5270	13.95	0.025	13.22	0.021	13.32	0.021	13.82	0.024	19.61	0.091	≤ 24.00
		5310	13.97	0.025	13.35	0.022	13.77	0.024	14.09	0.026	19.82	0.096	≤ 24.00
		5510	14.95	0.031	14.23	0.026	14.71	0.030	14.83	0.030	20.71	0.118	≤ 24.00
		5550	15.90	0.039	15.67	0.037	15.38	0.034	15.96	0.039	21.75	0.150	≤ 24.00
		5670	16.24	0.042	16.26	0.042	15.54	0.036	15.80	0.038	21.99	0.158	≤ 24.00
		5710	17.17	0.052	17.10	0.051	16.14	0.041	17.32	0.054	22.97	0.198	≤ 24.00
		5710	8.22	0.007	8.26	0.007	7.23	0.005	8.14	0.007	14.00	0.025	≤ 30.00
Mode 5	26 M	5260	14.17	0.026	14.15	0.026	14.25	0.027	14.58	0.029	20.31	0.107	≤ 24.00
		5280	14.50	0.028	14.52	0.028	14.69	0.029	14.59	0.029	20.60	0.115	≤ 24.00
		5320	13.70	0.023	14.66	0.029	14.94	0.031	14.62	0.029	20.53	0.113	≤ 24.00
		5500	13.56	0.023	13.20	0.021	12.71	0.019	13.39	0.022	19.25	0.084	≤ 24.00
		5560	13.23	0.021	13.50	0.022	13.24	0.021	13.68	0.023	19.44	0.088	≤ 24.00
		5700	13.74	0.024	13.79	0.024	12.61	0.018	13.61	0.023	19.48	0.089	≤ 24.00
		5720	14.57	0.029	14.89	0.031	14.23	0.027	15.04	0.032	20.72	0.118	≤ 24.00
		5720	9.72	0.009	10.07	0.010	9.42	0.009	10.30	0.011	15.92	0.039	≤ 30.00

Note: The relevant measured result has the offset with cable loss already.

Test Mode	Data Rate	Frequency (MHz)	Max. Output Power										Limit (dBm)
			ANT-0		ANT-1		ANT-2		ANT-3		ANT-0+1+2+3		
			(dBm)	(W)	(dBm)	(W)	(dBm)	(W)	(dBm)	(W)	(dBm)	(W)	
Mode 6	54 M	5270	13.75	0.024	13.25	0.021	13.65	0.023	13.46	0.022	19.55	0.090	≤ 24.00
		5310	13.89	0.025	13.35	0.022	13.74	0.024	14.09	0.026	19.80	0.095	≤ 24.00
		5510	14.95	0.031	14.21	0.026	14.74	0.030	14.88	0.031	20.72	0.118	≤ 24.00
		5550	15.70	0.037	15.43	0.035	15.31	0.034	15.56	0.036	21.52	0.142	≤ 24.00
		5670	15.93	0.039	15.94	0.039	15.39	0.035	15.57	0.036	21.74	0.149	≤ 24.00
		5710	17.19	0.052	17.14	0.052	16.27	0.042	17.29	0.054	23.01	0.200	≤ 24.00
		5710	8.32	0.007	8.36	0.007	7.44	0.006	8.26	0.007	14.13	0.026	≤ 30.00
Mode 7	117.2 M	5290	12.94	0.020	12.70	0.019	12.88	0.019	13.09	0.020	18.92	0.078	≤ 24.00
		5530	13.96	0.025	13.72	0.024	14.38	0.027	14.20	0.026	20.09	0.102	≤ 24.00
		5610	15.10	0.032	14.62	0.029	15.54	0.036	15.05	0.032	21.11	0.129	≤ 24.00
		5690	17.10	0.051	17.57	0.057	16.78	0.048	17.44	0.055	23.25	0.211	≤ 24.00
		5690	4.51	0.003	4.84	0.003	4.20	0.003	4.89	0.003	10.64	0.012	≤ 30.00
Mode 8	MCS0	5260	14.42	0.028	14.32	0.027	14.46	0.028	14.53	0.028	20.45	0.111	≤ 24.00
		5280	14.73	0.030	14.78	0.030	14.98	0.031	14.82	0.030	20.85	0.122	≤ 24.00
		5320	14.03	0.025	14.95	0.031	15.14	0.033	14.77	0.030	20.76	0.119	≤ 24.00
		5500	13.92	0.025	13.51	0.022	13.02	0.020	13.54	0.023	19.53	0.090	≤ 24.00
		5560	13.63	0.023	13.89	0.025	13.56	0.023	13.99	0.025	19.79	0.095	≤ 24.00
		5700	13.93	0.025	14.03	0.025	12.96	0.020	13.93	0.025	19.76	0.095	≤ 24.00
		5720	14.74	0.030	14.78	0.030	14.37	0.027	15.08	0.032	20.77	0.119	≤ 24.00
		5720	9.93	0.010	9.78	0.010	9.57	0.009	10.26	0.011	15.91	0.039	≤ 30.00
Mode 9	MCS0	5270	14.18	0.026	13.72	0.024	14.18	0.026	13.98	0.025	20.04	0.101	≤ 24.00
		5310	14.42	0.028	13.85	0.024	14.22	0.026	14.61	0.029	20.31	0.107	≤ 24.00
		5510	15.42	0.035	14.70	0.030	15.19	0.033	15.36	0.034	21.20	0.132	≤ 24.00
		5550	16.00	0.040	15.86	0.039	15.40	0.035	15.96	0.039	21.83	0.152	≤ 24.00
		5670	16.32	0.043	16.41	0.044	15.63	0.037	15.92	0.039	22.10	0.162	≤ 24.00
		5710	17.37	0.055	17.40	0.055	16.53	0.045	17.38	0.055	23.21	0.209	≤ 24.00
		5710	8.38	0.007	8.38	0.007	7.63	0.006	8.49	0.007	14.25	0.027	≤ 30.00
Mode 10	MCS0	5290	13.16	0.021	12.99	0.020	13.05	0.020	13.28	0.021	19.14	0.082	≤ 24.00
		5530	14.18	0.026	13.99	0.025	14.63	0.029	14.39	0.028	20.33	0.108	≤ 24.00
		5610	17.78	0.060	17.59	0.057	17.15	0.052	17.20	0.052	23.46	0.222	≤ 24.00
		5690	17.25	0.053	17.20	0.053	16.77	0.048	17.57	0.057	23.23	0.210	≤ 24.00
		5690	4.66	0.003	4.61	0.003	4.14	0.003	4.96	0.003	10.62	0.012	≤ 30.00

Note: The relevant measured result has the offset with cable loss already.

Test Mode	Data Rate	Frequency (MHz)	Low TPC Power										Limit (dBm)
			ANT-0		ANT-1		ANT-2		ANT-3		ANT-0+1+2+3		
			(dBm)	(W)	(dBm)	(W)	(dBm)	(W)	(dBm)	(W)	(dBm)	(W)	
Mode 3	26 M	5260	13.21	0.021	13.08	0.020	13.14	0.021	13.03	0.020	19.14	0.082	≤ 24.00
		5280	12.90	0.019	13.17	0.021	13.22	0.021	12.97	0.020	19.09	0.081	≤ 24.00
		5320	12.49	0.018	13.35	0.022	13.44	0.022	13.20	0.021	19.16	0.082	≤ 24.00
		5500	13.34	0.022	13.09	0.020	12.55	0.018	12.85	0.019	18.99	0.079	≤ 24.00
		5560	12.44	0.018	12.70	0.019	12.48	0.018	12.91	0.020	18.66	0.073	≤ 24.00
		5700	12.65	0.018	12.91	0.020	11.94	0.016	12.46	0.018	18.52	0.071	≤ 24.00
Mode 4	54 M	5270	12.91	0.020	12.32	0.017	12.22	0.017	12.92	0.020	18.63	0.073	≤ 24.00
		5310	12.77	0.019	12.25	0.017	12.67	0.019	13.89	0.024	18.96	0.079	≤ 24.00
		5510	13.15	0.021	13.27	0.021	12.77	0.019	12.83	0.019	19.03	0.080	≤ 24.00
		5550	13.14	0.021	13.37	0.022	13.18	0.021	12.46	0.018	19.07	0.081	≤ 24.00
		5670	13.14	0.021	13.22	0.021	12.49	0.018	12.90	0.019	18.97	0.079	≤ 24.00
Mode 5	26 M	5260	12.97	0.020	12.91	0.020	13.25	0.021	13.24	0.021	19.12	0.082	≤ 24.00
		5280	13.10	0.020	12.88	0.019	13.19	0.021	13.22	0.021	19.12	0.082	≤ 24.00
		5320	12.75	0.019	12.96	0.020	13.14	0.021	13.22	0.021	19.04	0.080	≤ 24.00
		5500	12.96	0.020	12.70	0.019	12.26	0.017	12.79	0.019	18.71	0.074	≤ 24.00
		5560	12.63	0.018	12.90	0.020	12.64	0.018	13.13	0.021	18.85	0.077	≤ 24.00
		5700	13.20	0.021	13.23	0.021	12.13	0.016	13.16	0.021	18.97	0.079	≤ 24.00
Mode 6	54 M	5270	13.14	0.021	12.74	0.019	13.08	0.020	12.91	0.020	18.99	0.079	≤ 24.00
		5310	12.85	0.019	12.39	0.017	12.71	0.019	13.19	0.021	18.82	0.076	≤ 24.00
		5510	13.35	0.022	12.71	0.019	13.14	0.021	13.29	0.021	19.15	0.082	≤ 24.00
		5550	12.69	0.019	12.53	0.018	12.74	0.019	12.63	0.018	18.67	0.074	≤ 24.00
		5670	13.26	0.021	13.31	0.021	12.76	0.019	13.03	0.020	19.12	0.082	≤ 24.00
Mode 7	117.2 M	5290	12.94	0.020	12.70	0.019	12.88	0.019	13.09	0.020	18.92	0.078	≤ 24.00
		5530	12.86	0.019	12.76	0.019	13.38	0.022	13.26	0.021	19.09	0.081	≤ 24.00
		5610	12.90	0.019	12.48	0.018	13.48	0.022	13.01	0.020	19.00	0.079	≤ 24.00
Mode 8	MCS0	5260	12.98	0.020	12.90	0.019	13.07	0.020	13.18	0.021	19.06	0.081	≤ 24.00
		5280	12.97	0.020	13.18	0.021	13.04	0.020	12.82	0.019	19.02	0.080	≤ 24.00
		5320	12.83	0.019	13.05	0.020	13.21	0.021	13.19	0.021	19.09	0.081	≤ 24.00
		5500	13.31	0.021	12.89	0.019	12.68	0.019	12.93	0.020	18.98	0.079	≤ 24.00
		5560	12.92	0.020	13.07	0.020	12.88	0.019	13.28	0.021	19.06	0.081	≤ 24.00
		5700	12.98	0.020	13.01	0.020	12.09	0.016	12.89	0.019	18.78	0.076	≤ 24.00
Mode 9	MCS0	5270	12.68	0.019	12.32	0.017	12.64	0.018	12.58	0.018	18.58	0.072	≤ 24.00
		5310	12.82	0.019	12.64	0.018	12.69	0.019	12.94	0.020	18.80	0.076	≤ 24.00
		5510	13.12	0.021	12.68	0.019	12.79	0.019	13.22	0.021	18.98	0.079	≤ 24.00
		5550	12.93	0.020	12.90	0.019	12.48	0.018	12.98	0.020	18.85	0.077	≤ 24.00
		5670	13.32	0.021	13.41	0.022	12.63	0.018	12.92	0.020	19.10	0.081	≤ 24.00
Mode 10	MCS0	5290	12.84	0.019	12.57	0.018	12.75	0.019	12.81	0.019	18.77	0.075	≤ 24.00
		5530	12.83	0.019	12.67	0.018	13.22	0.021	13.17	0.021	19.00	0.079	≤ 24.00
		5610	13.23	0.021	13.05	0.020	12.63	0.018	12.62	0.018	18.91	0.078	≤ 24.00

Note: The relevant measured result has the offset with cable loss already.

Test Mode	Data Rate	Frequency (MHz)	Low TPC Power			Limit (dBm)
			Max. Low TPC Power	Max. Gain	E.I.R.P.	
			(dBm)	(dBi)	(dBm)	
Mode 3	26 M	5260	19.14	4.81	23.95	≤ 24.00
		5280	19.09	4.81	23.90	≤ 24.00
		5320	19.16	4.81	23.97	≤ 24.00
		5500	18.99	4.81	23.80	≤ 24.00
		5560	18.66	4.81	23.47	≤ 24.00
		5700	18.52	4.81	23.33	≤ 24.00
Mode 4	54 M	5270	18.63	4.81	23.44	≤ 24.00
		5310	18.96	4.81	23.77	≤ 24.00
		5510	19.03	4.81	23.84	≤ 24.00
		5550	19.07	4.81	23.88	≤ 24.00
		5670	18.97	4.81	23.78	≤ 24.00
Mode 5	26 M	5260	19.12	4.81	23.93	≤ 24.00
		5280	19.12	4.81	23.93	≤ 24.00
		5320	19.04	4.81	23.85	≤ 24.00
		5500	18.71	4.81	23.52	≤ 24.00
		5560	18.85	4.81	23.66	≤ 24.00
		5700	18.97	4.81	23.78	≤ 24.00
Mode 6	54 M	5270	18.99	4.81	23.80	≤ 24.00
		5310	18.82	4.81	23.63	≤ 24.00
		5510	19.15	4.81	23.96	≤ 24.00
		5550	18.67	4.81	23.48	≤ 24.00
		5670	19.12	4.81	23.93	≤ 24.00
Mode 7	117.2 M	5290	18.92	4.81	23.73	≤ 24.00
		5530	19.09	4.81	23.90	≤ 24.00
		5610	19.00	4.81	23.81	≤ 24.00
Mode 8	MCS0	5260	19.06	4.81	23.87	≤ 24.00
		5280	19.02	4.81	23.83	≤ 24.00
		5320	19.09	4.81	23.90	≤ 24.00
		5500	18.98	4.81	23.79	≤ 24.00
		5560	19.06	4.81	23.87	≤ 24.00
		5700	18.78	4.81	23.59	≤ 24.00
Mode 9	MCS0	5270	18.58	4.81	23.39	≤ 24.00
		5310	18.80	4.81	23.61	≤ 24.00
		5510	18.98	4.81	23.79	≤ 24.00
		5550	18.85	4.81	23.66	≤ 24.00
		5670	19.10	4.81	23.91	≤ 24.00
Mode 10	MCS0	5290	18.77	4.81	23.58	≤ 24.00
		5530	19.00	4.81	23.81	≤ 24.00
		5610	18.91	4.81	23.72	≤ 24.00

Note: The relevant measured result has the offset with cable loss already.