

# Music fountain aromatherapy machine operating instruction

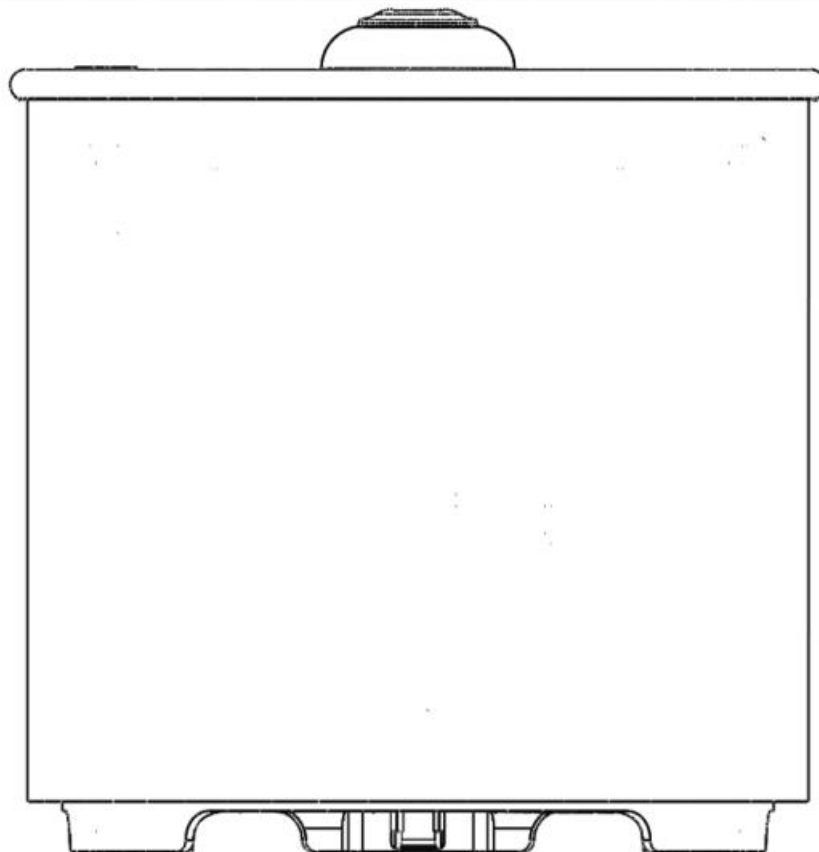

MADE IN CHINA

## \* size of product

[product name] Diffuser & Fountain

[Power supply] power line 24V, Fan 24V, Fan speed/3500R/h

[wire length] about 150CM

[rated power] spray volume power 16W

[working time] spray volume 12 hours  $\pm 1$  hour

[principle of aromatherapy] Water and aromatherapy essential oil are vibrated at high frequency by ultrasonic atomization sheet. The mixture of (plant essential oil) floats out in tiny molecular clusters, The fragrant essential oil molecules are not heated and evaporated, and can enjoy the natural cleaning. The new pure scents.

[Abnormal vibration frequency] 2.4 MHz

[Maximum effective capacity] 250ML

[The number of LED] 6 full color LED light 16 gradual change color.

[The main material of the main material is ] PP, ABS and PCB.

[fittings ] Power cord, instruction

## \*product diagram

- A. Fog outlet (outlet)
- B. Water retaining cover
- C. radiator cap
- D. water box
- E. cover
- F. receiver of remote-control system
- G. Light switch (Long press the volume "-")
- H. air intake
- I. DC seat
- J. Fountain。 Spray. Light switch, long press 1S built-in
- K. Music on, long by 3S Bluetooth connection mode
- L. Fountain switch (Long press the volume "+")
- M. Music
- N. Switch
- O. Spray key
- P. Light key
- Q. Volume "-"
- R. Last song
- S. Pause/ play
- T. Music key
- U. Mute key
- V. Fountain key
- W. Blue tooth key[SXH-BT]
- X. Volume "+"
- Y. Next song
- Z. Maximum water level

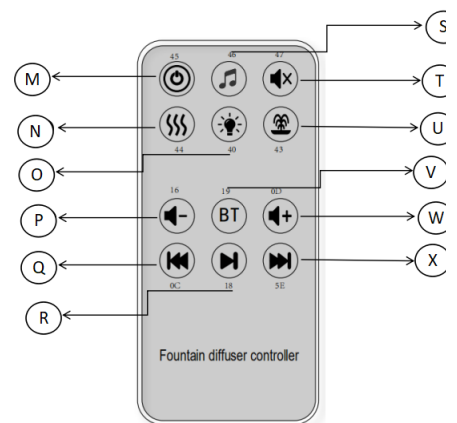
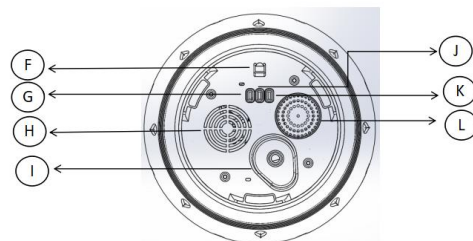
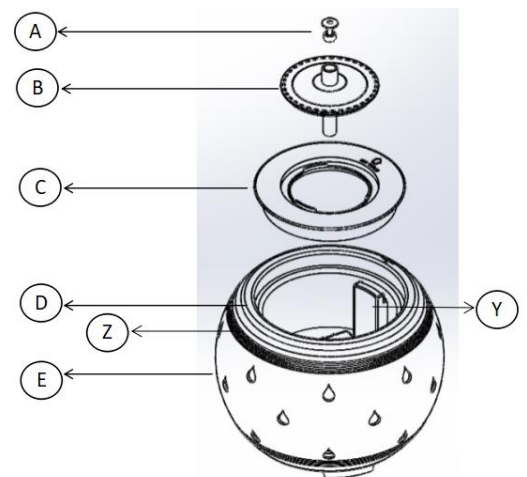

## \*Functional / usage instructions

Thank you for using our products. In order to make you use this product safely and comfortably, please read this manual carefully and operate accurately as required.

1. Please straighten the product and remove the water shield vertically;
2. Please remove the lid of the tank;
3. Please insert the DC head of the adapter into the DC Jack at the bottom of the product;
4. Please use the cup to add water to the tank, do not exceed the maximum water level. Do not add water in the use of the product, do not use water with too high temperature. Then drop in aromatherapy essential oil. (it is recommended that 0.1-0.15ML essential oil be dripped into water per 100ML)
5. After the water is added into the water tank, the water tank cover and the water retaining cover are covered so that the lid and the body are sealed;
6. Please insert the adapter plug into the plug-in jack, at which point the machine is in standby mode;
7. Press the primary "J" key to turn on the light. Spray. Fountain, press the second off. The "J" key length is switched on according to the built-in music of 1s, and the long-press 3-S Bluetooth connection mode;
8. Press the primary "G" key light to turn on the light automatic circulation gradient mode. Press the second time to turn on the color setting light mode and press the volume "-". In the case of music opening, press the "Last song" once;
9. Press the "K" key fountain mode and press the volume "-" for the second time. Press a "Next tune" in the event of a music on;
10. Press the "M" key to turn on the light. Spray. Fountain, press second off;
11. Press the "S" key to turn on the music;
12. Press the "T" key to mute the mode;
13. Press the "N" key to atomize and turn it off for the second time;
14. Press the "O" key at a time to turn on the light automatic circulation gradient mode, and press the second time to turn on the color selection mode.;
15. Press the "u" key to open the fountain mode and press the second time off;
16. Press "P" key volume "-";
17. Press "V" key Bluetooth connection mode;
18. Press the "W" key volume "+";
19. Press the "Q" key on the song;
20. Pause/ play by "R" key;
21. Press the "X" key to next song;
22. In the case of water shortage, the machine will automatically protect the switch and stop working;



Water



air



plants



mood





household

## \*matters need attention

Observe the following precautions to ensure the use of safety

 The non-technical personnel shall not be allowed to modify, dismantle or repair the product without permission. For repair, please contact the product sales department.

 This product is prohibited from medical ventilator, the fog from the tuyere of this product should not be aimed directly at the respiratory tract.

 Do not stab, detach, twist, stretch power cord. Do not place the power cord at high temperature.

 No maintenance: please use neutral detergent to clean this product, do not use other types of detergent.

 If the socket is loose, stop using it.

 During maintenance, be sure to unplug the adapter from the power supply and socket.

 Prohibition Do not use this product in high altitude, bevel, shelf or unstable place.

 Do not place nails, needles and other sundries at the vents or seams of the main body.

 If it is forbidden to maintain or pour out the water in the container, it is necessary to pour out the water from the drain side in accordance with the water-pouring method in the instruction manual.

 Use greenhouse tap water or purified water, replace the water in the container every day, wash the inner wall of the container often, keep the product clean and use

 Warning if the meaning of the logo is ignored, resulting in improper operation, may cause harm to the user, and may damage this product;

## **\*Accidental drag leakage**

**If you accidentally knock over when you use it, please do so:**

1. Turn off the power supply, unplug the power cord and open the upper cover;
2. Completely pour out the remaining water in the tank from the drainage test;
3. Gently shake fuselage, let the body drain water from the drain, placed in a safe position for 24 hours;

## **\*Product maintenance method**

In order to ensure the safe use of this product, please be sure to maintain it on a regular basis. It is recommended to maintain every 5 times or 2 times in a row after 3 days. Please maintain this product in the following ways.

- 1、 Pull the adapter out of the power socket and remove the body cover from the body. Do not tilt.
- 2、 If there is still water left in the container cup, the main body must tilt towards the drain side and bring the water out.  
    ✘ In order to prevent water from flowing into the main body from the tuyere, do not pour water out of the side of the vents.
- 3、 Remove the adapter from the body.
- 4、 First, put a small amount of the detergent used in the kitchen into the warm water for dilution, and then soak the cloth in the water for soaking. Soak out and wring dry before wiping this product.
5. After maintenance, use a cup of clean water into the container, work for 30 minutes, pour out the water, And then dry the water.

## \* failure cause

If the product cannot work properly, should first refer to the following circumstances:

If you feel that there may be a barrier to this product, please confirm the following before asking us for repair:	
As soon as the spray switch is turned on, the product will automatically shut down in less than a second.	<ul style="list-style-type: none"> <li>● Please make sure there is any water in the container? Or is there enough water? ---Please add water to the container;</li> <li>● Is the adapter connected to the product? ---Please confirm that this product is connected to the adapter. To verify that the DC header is connected, remove the DC header from the ontology again and plug it in again and try again.</li> </ul>
No spray or spray abnormality.	<ul style="list-style-type: none"> <li>● Is there too little water in the tank? Or too much? ---Please add water to the water tank. An exception may occur if the water in the tank exceeds the maximum level line spray.</li> <li>● Whether the ultrasonic wave has dirt? ---Please clean the water tank and atomization sheet. (please refer to "Product maintenance")</li> <li>● Is the air inlet at the bottom covered with dust? ---If the air inlet on the base is covered with dust, the amount of exhaust will be greatly reduced, resulting in the lack of sufficient wind to spray the mist.</li> </ul>
No water spray or water spray.	<ul style="list-style-type: none"> <li>● Is there a shortage of water in the water tank? ---Fill the water tank with water</li> </ul>
Spray only, not spray water.	<ul style="list-style-type: none"> <li>● Is there a shortage of water in the water tank? ---Please add water to the water tank, the pump will automatically stop working in the case of water shortage, and the spray will continue to work when the spray minimum water level is not reached.</li> </ul>
Product water leakage.	<ul style="list-style-type: none"> <li>● Whether or not the water tank cover and water retaining cover are covered? ---Re-cover the inner and upper covers.</li> <li>● The temperature is too low or the humidity is too high? ---If the ambient temperature is too low or the humidity is too high, the fog on its surface can easily gather together to form water droplets.</li> </ul>

## FCC Warning

This device complies with part 15 of the FCC rules. Operation is subject to the following two conditions: (1) this device may not cause harmful interference, and (2) this device must accept any interference received, including interference that may cause undesired operation.

Changes or modifications not expressly approved by the party responsible for compliance could void the user's authority to operate the equipment.

NOTE: This equipment has been tested and found to comply with the limits for a Class B digital device, pursuant to part 15 of the FCC Rules. These limits are designed to provide reasonable protection against harmful interference in a residential installation. This equipment generates uses and can radiate radio frequency energy and, if not installed and used in accordance with the instructions, may cause harmful interference to radio communications. However, there is no guarantee that interference will not occur in a particular installation. If this equipment does cause harmful interference to radio or television reception, which can be determined by turning the equipment off and on, the user is encouraged to try to correct the interference by one or more of the following measures:

-Reorient or relocate the receiving antenna.

•Increase the separation between the equipment and receiver.

•Connect the equipment into an outlet on a circuit different from that to which the receiver is connected.

•Consult the dealer or an experienced radio/TV technician for help.

## Radiation Exposure Statement

This equipment complies with FCC radiation exposure limits set forth for an uncontrolled environment. This equipment should be installed and operated with minimum distance 20cm between the radiator and your body.

## ISED Statement

- English: This device complies with Industry Canada license - exempt RSS standard(s). Operation is subject to the following two conditions: (1) This device may not cause interference, and (2) This device must accept any interference, including interference that may cause undesired operation of the device.

The digital apparatus complies with Canadian CAN ICES - 3 (B)/NMB - 3(B).

- French: Le présent appareil est conforme aux CNR d'Industrie Canada applicables aux appareils radio exempts de licence. L'exploitation est autorisée aux deux conditions suivantes: (1) l'appareil ne doit pas produire de brouillage, et (2) l'utilisateur de l'appareil doit accepter tout brouillage radioélectrique subi, même si le brouillage est susceptible d'en compromettre le fonctionnement.

l'appareil numérique du ciem conforme canadien peut - 3 (b) / nmb - 3 (b).

This device meets the exemption from the routine evaluation limits in section 2.5 of RSS 102 and compliance with RSS 102 RF exposure, users can obtain Canadian information on RF exposure and compliance.

cet appareil est conforme à l'exemption des limites d'évaluation courante dans la section 2.5 du cnr - 102 et conformité avec rss 102 de l'exposition aux rf, les utilisateurs peuvent obtenir des données canadiennes sur l'exposition aux champs rf et la conformité.

This equipment complies with Canada radiation exposure limits set forth for an uncontrolled environment.

This equipment should be installed and operated with minimum distance 20cm between the radiator & your body.

Cet équipement est conforme Canada limites d'exposition aux radiations dans un environnement non contrôlé.

Cet équipement doit être installé et utilisé à une distance minimale de 20 cm entre le radiateur et votre corps.