

Project No.: TM-2207000268P
 Report No.: TMWK2207002918KR

FCC ID: 2AX7S-LN313B

Page: 1 / 85
 Rev.: 00

RADIO TEST REPORT

FCC 47 CFR PART 15 SUBPART C

Test Standard	FCC Part 15.247
Product name	E-note device
Brand Name	ITOCHU
Model No.	USMUK4
Test Result	Pass
Statements of Conformity	Determination of compliance is based on the results of the compliance measurement, not taking into account measurement instrumentation uncertainty.

The test Result was tested by Compliance Certification Services Inc. The test data, data evaluation, test procedures, and equipment configurations shown in this report were given in ANSI C63.10: 2013 and compliance standards.

The test results of this report relate only to the tested sample (EUT) identified in this report.

The test Report of full or partial shall not copy. Without written approval of Compliance Certification Services Inc. (Wugu Laboratory)

Approved by:



Shawn Wu
 Supervisor

Unless otherwise stated the results shown in this test report refer only to the sample(s) tested and such sample(s) are retained for 90 days only.
 除非另有說明，此報告結果僅對測試之樣品負責，同時此樣品僅保留90天。本報告未經本公司書面許可，不可部份複製。

This document is issued by the Company subject to its General Conditions of Service printed overleaf, available on request or accessible at <http://www.sgs.com.tw/Terms-and-Conditions> and, for electronic format documents, subject to Terms and Conditions for Electronic Documents at <http://www.sgs.com.tw/Terms-and-Conditions>. Attention is drawn to the limitation of liability, indemnification and jurisdiction issues defined therein. Any holder of this document is advised that information contained hereon reflects the Company's findings at the time of its intervention only and within the limits of client's instruction, if any. The Company's sole responsibility is to its Client and this document does not exonerate parties to a transaction from exercising all their rights and obligations under the transaction documents. This document cannot be reproduced, except in full, without prior written approval of the Company. Any unauthorized alteration, forgery or falsification of the content or appearance of this document is unlawful and offenders may be prosecuted to the fullest extent of the law.

Revision History

Rev.	Issue Date	Revisions	Effect Page	Revised By
00	September 2, 2022	Initial Issue	ALL	Allison Chen

Table of contents

1.	GENERAL INFORMATION	4
1.1	EUT INFORMATION.....	4
1.2	INFORMATION ABOUT THE FHSS CHARACTERISTICS.....	5
1.3	EUT CHANNEL INFORMATION	6
1.4	ANTENNA INFORMATION	6
1.5	MEASUREMENT UNCERTAINTY.....	7
1.6	FACILITIES AND TEST LOCATION	8
1.7	INSTRUMENT CALIBRATION	8
1.8	SUPPORT AND EUT ACCESSORIES EQUIPMENT	10
1.9	TEST METHODOLOGY AND APPLIED STANDARDS	10
2.	TEST SUMMARY	11
3.	DESCRIPTION OF TEST MODES.....	12
3.1	THE WORST MODE OF OPERATING CONDITION	12
3.2	THE WORST MODE OF MEASUREMENT	13
3.3	EUT DUTY CYCLE.....	14
4.	TEST RESULT	17
4.1	AC POWER LINE CONDUCTED EMISSION	17
4.2	20DB BANDWIDTH AND OCCUPIED BANDWIDTH (99%)	30
4.3	OUTPUT POWER MEASUREMENT	36
4.4	FREQUENCY SEPARATION	38
4.5	NUMBER OF HOPPING	42
4.6	CONDUCTED BANDEDGE AND SPURIOUS EMISSION.....	45
4.7	TIME OF OCCUPANCY (DWELL TIME)	52
4.8	RADIATION BANDEDGE AND SPURIOUS EMISSION	56
APPENDIX 1 - PHOTOGRAPHS OF EUT		

Report No.: TMWK2207002918KR

1. GENERAL INFORMATION

1.1 EUT INFORMATION

Applicant	AIMobile Co., Ltd. 6F., No. 166, Sec.4, Chengde Rd., Shilin Dist., Taipei City 11167, Taiwan
Manufacturer	AIMobile Co., Ltd. 6F., No. 166, Sec.4, Chengde Rd., Shilin Dist., Taipei City 11167, Taiwan
Equipment	E-note device
Model Name	USMUK4
Model Discrepancy	N/A
Brand Name	ITOCHU
Received Date	July 19, 2022
Date of Test	July 29 ~ August 16, 2022
Power Supply	1. Power from Host System. Rechargeable Li-Polymer Battery / LIS1633RDPCA Rating: 2000mAh, 7.4Wh 2. Power from Adapter.

Remark:

1. For more details, please refer to the User's manual of the EUT.
2. Disclaimer: Antenna information is provided by the applicant, test results of this report are applicable to the sample EUT received.

1.2 INFORMATION ABOUT THE FHSS CHARACTERISTICS

1.2.1 Pseudorandom Frequency Hopping Sequence

The channel is represented by a pseudo-random hopping sequence hopping through the 79 RF channels. The hopping sequence is unique for the piconet and is determined by the Bluetooth device address of the master; the phase in the hopping sequence is determined by the Bluetooth clock of the master. The channel is divided into time slots where each slot corresponds to an RF hop frequency. Consecutive hops correspond to different RF hop frequencies. The nominal hop rate is 1 600 hops/s.

1.2.2 Equal Hopping Frequency Use

The channels of this system will be used equally over the long-term distribution of the hopsets.

1.2.3 Example of a 79 hopping sequence in data mode:

02, 05, 31, 24, 20, 10, 43, 36, 30, 23, 40, 06, 21, 50, 44, 09, 71, 78, 01, 13, 73, 07, 70, 72, 35, 62, 42, 11, 41, 08, 16, 29, 60, 15, 34, 61, 58, 04, 67, 12, 22, 53, 57, 18, 27, 76, 39, 32, 17, 77, 52, 33, 56, 46, 37, 47, 64, 49, 45, 38, 69, 14, 51, 26, 79, 19, 28, 65, 75, 54, 48, 03, 25, 66, 05, 16, 68, 74, 59, 63, 55

1.2.4 System Receiver Input Bandwidth

Each channel bandwidth is 1MHz.

The system receivers have input bandwidths that match the hopping channel bandwidths of their corresponding transmitters and shift frequencies in synchronization with the transmitted signals.

1.2.5 Equipment Description

15.247(a)(1) that the Rx input bandwidths shift frequencies in synchronization with the transmitted signals.

15.247(g): In accordance with the Bluetooth Industry Standard, the system is designed to comply with all of the regulations in Section 15.247 when the transmitter is presented with a continuous data (or information) system.

15.247(h): In accordance with the Bluetooth Industry Standard, the system does not coordinate its channels selection/ hopping sequence with other frequency hopping systems for the express purpose of avoiding the simultaneous occupancy of individual hopping frequencies by multiple transmitters.

Report No.: TMWK2207002918KR

1.3 EUT CHANNEL INFORMATION

Frequency Range	2402MHz-2480MHz
Modulation Type	1. GFSK for BDR-1Mbps 2. $\pi/4$ -DQPSK for EDR-2Mbps 3. 8DPSK for EDR-3Mbps
Number of channel	79 Channels

Remark:

Refer as ANSI C63.10: 2013 clause 5.6.1 Table 4 for test channels

Number of frequencies to be tested		
Frequency range in which device operates	Number of frequencies	Location in frequency range of operation
<input type="checkbox"/> 1 MHz or less	1	Middle
<input type="checkbox"/> 1 MHz to 10 MHz	2	1 near top and 1 near bottom
<input checked="" type="checkbox"/> More than 10 MHz	3	1 near top, 1 near middle, and 1 near bottom

1.4 ANTENNA INFORMATION

Antenna Specification	<input checked="" type="checkbox"/> PIFA <input type="checkbox"/> PCB <input type="checkbox"/> Dipole <input type="checkbox"/> Coils
Antenna Gain	Gain: 2.58 dBi
Brand / Model	YAGEO / LN313 (ANTA0ZV1421124554)
Antenna Connector	IPEX

Notes:

1. The antenna(s) of the EUT are permanently attached and there are no provisions for connection to an external antenna. So the EUT complies with the requirements of §15.203.

1.5 MEASUREMENT UNCERTAINTY

PARAMETER	UNCERTAINTY
AC Powerline Conducted Emission	± 2.1183
Channel Bandwidth	± 2.1863
RF output power (Power Meter + Power sensor)	± 1.2688
Power Spectral density	± 2.1855
Conducted Bandedge	± 2.1866
Conducted Spurious Emission	± 2.1859
Radiated Emission_9kHz-30MHz	± 3.814
Radiated Emission_30MHz-200MHz	± 4.272
Radiated Emission_200MHz-1GHz	± 4.619
Radiated Emission_1GHz-6GHz	± 5.522
Radiated Emission_6GHz-18GHz	± 5.228
Radiated Emission_18GHz-26GHz	± 4.089
Radiated Emission_26GHz-40GHz	± 4.019

Remark:

- 1.This uncertainty represents an expanded uncertainty expressed at approximately the 95% confidence level using a coverage factor of k=2
2. ISO/IEC 17025 requires that an estimate of the measurement uncertainties associated with the emissions test results be included in the report.

1.6 FACILITIES AND TEST LOCATION

All measurement facilities used to collect the measurement data are located at No.11, Wugong 6th Rd., Wugu Dist., New Taipei City, Taiwan. (R.O.C.)
CAB identifier: TW1309

Test site	Test Engineer	Remark
AC Conduction Room	Tony Chao	-
Radiation	Ray Li, Tony Chao	-
RF Conducted	David Li	-

Remark: The lab has been recognized as the FCC accredited lab. under the KDB 974614 D01 and is listed in the FCC public Access Link (PAL) database, FCC Registration No. :444940, the FCC Designation No.:TW1309”

1.7 INSTRUMENT CALIBRATION

AC line Conduction Test Room					
Name of Equipment	Manufacturer	Model	Serial Number	Calibration Date	Calibration Due
CABLE	EMCI	CFD300-NL	CERF	06/27/2022	06/26/2023
EMI Test Receiver	R&S	ESCI	100064	06/17/2022	06/16/2023
LISN	SCHAFFNER	NNB 41	03/10013	02/15/2022	02/14/2023
Software	EZ-EMC(CCS-3A1-CE-wugu)				

RF Conducted Test Site					
Name of Equipment	Manufacturer	Model	Serial Number	Calibration Date	Calibration Due
EXA Signal Analyzer	KEYSIGHT	N9010B	MY55460167	09/07/2021	09/06/2022
Power Meter	Anritsu	ML2496A	2136002	12/06/2021	12/05/2022
Power Seneor	Anritsu	MA2411B	1911386	08/19/2021	08/18/2022
Power Seneor	Anritsu	MA2411B	1911387	08/19/2021	08/18/2022
Software	Radio Test Software Ver. 21				

Remark:

1. Each piece of equipment is scheduled for calibration once a year.
2. N.C.R. = No Calibration Required.

3M 966A Chamber					
Name of Equipment	Manufacturer	Model	Serial Number	Calibration Date	Calibration Due
Band Reject Filters	MICRO TRONICS	BRM 50702	112	11/23/2021	11/22/2022
Bilog Antenna	Sunol Sciences	JB3	A030105	08/03/2022	08/02/2023
Coaxial Cable	HUBER SUHNER	SUCOFLEX 104PEA	20995	02/23/2022	02/22/2023
Coaxial Cable	Woken	J-1099	201709090004	12/23/2021	12/22/2022
Coaxial Cable	EMCI	EMC105	190914+33953	06/15/2022	06/14/2023
Digital Thermo-Hygro Meter	WISEWIND	1206	D07	12/28/2021	12/27/2022
Horn Antenna	ETS LINDGREN	3116	00026370	11/30/2021	11/29/2022
Horn Antenna	MCTD	1209	DRH13M02003	01/25/2022	01/24/2023
K Type Cable	Huber+Suhner	SUCOFLEX 102	29406/2	12/05/2021	12/04/2022
Pre-Amplifier	EMEC	EM330	060609	02/23/2022	02/22/2023
Pre-Amplifier	HP	8449B	3008A00965	12/24/2021	12/23/2022
PSA Series Spectrum Analyzer	Agilent	E4446A	MY46180323	12/06/2021	12/05/2022
Antenna Tower	CCS	CC-A-1F	N/A	N.C.R	N.C.R
Controller	CCS	CC-C-1F	N/A	N.C.R	N.C.R
Turn Table	CCS	CC-T-1F	N/A	N.C.R	N.C.R
Software	e3 210616				

Remark:

1. Each piece of equipment is scheduled for calibration once a year.
2. N.C.R. = No Calibration Required.

1.8 SUPPORT AND EUT ACCESSORIES EQUIPMENT

EUT Accessories Equipment						
No.	Equipment	Brand	Model	Series No.	FCC ID	IC
	N/A					

Support Equipment						
No.	Equipment	Brand	Model	Series No.	FCC ID	IC
1	Adapter	Alcatel	UC13US	N/A	N/A	N/A
2	NB(G)	Lenovo	IBM 1951	N/A	N/A	N/A

1.9 TEST METHODOLOGY AND APPLIED STANDARDS

The test methodology, setups and results comply with all requirements in accordance with ANSI C63.10:2013, FCC Part 2, FCC Part 15.247.

2. TEST SUMMARY

FCC Standard Section	Report Section	Test Item	Result
15.203	1.3	Antenna Requirement	Pass
15.207(a)	4.1	AC Conducted Emission	Pass
15.247(a)(1)	4.2	20 dB Bandwidth	Pass
-	4.2	Occupied Bandwidth (99%)	Pass
15.247(b)(1)	4.3	Output Power Measurement	Pass
15.247(a)(1)	4.4	Frequency Separation	Pass
15.247(a)(1)(iii)	4.5	Number of Hopping	Pass
15.247(d)	4.6	Conducted Band Edge	Pass
15.247(d)	4.6	Conducted Spurious Emission	Pass
15.247(a)(1)(iii)	4.7	Time of Occupancy	Pass
15.247(d)	4.8	Radiation Band Edge	Pass
15.247(d)	4.8	Radiation Spurious Emission	Pass

Report No.: TMWK2207002918KR

3. DESCRIPTION OF TEST MODES

3.1 THE WORST MODE OF OPERATING CONDITION

Operation mode	GFSK for BDR-1Mbps (DH5) 8DPSK for EDR-3Mbps (3DH5)
Test Channel Frequencies	<p>GFSK for BDR-1Mbps: 1.Lowest Channel: 2402MHz 2.Middle Channel: 2441MHz 3.Highest Channel: 2480MHz</p> <p>8DPSK for EDR-3Mbps: 1.Lowest Channel: 2402MHz 2.Middle Channel: 2441MHz 3.Highest Channel: 2480MHz</p>

Remark:

1. EUT pre-scanned data rate of output power for each mode, the worst data rate were recorded in this report.

Report No.: TMWK2207002918KR

3.2 THE WORST MODE OF MEASUREMENT

AC Power Line Conducted Emission	
Test Condition	AC Power line conducted emission for line and neutral
Power supply Mode	Mode 1: EUT power by Adapter Mode 2: EUT power by Notebook
Worst Mode	<input checked="" type="checkbox"/> Mode 1 <input type="checkbox"/> Mode 2 <input type="checkbox"/> Mode 3 <input type="checkbox"/> Mode 4

Remark:

1. The worst mode was record in this test report.
2. AC power line conducted emission and for below 1G radiation emission were performed the EUT transmit at the highest output power channel as

Radiated Emission Measurement Above 1G	
Test Condition	Radiated Emission Above 1G
Power supply Mode	Mode 1: EUT power by Host System
Worst Mode	<input checked="" type="checkbox"/> Mode 1 <input type="checkbox"/> Mode 2 <input type="checkbox"/> Mode 3 <input type="checkbox"/> Mode 4
Worst Position	<input type="checkbox"/> Placed in fixed position. <input checked="" type="checkbox"/> Placed in fixed position at X-Plane (E2-Plane) <input type="checkbox"/> Placed in fixed position at Y-Plane (E1-Plane) <input type="checkbox"/> Placed in fixed position at Z-Plane (H-Plane)

Radiated Emission Measurement Below 1G	
Test Condition	Radiated Emission Below 1G
Power supply Mode	Mode 1: EUT power by Host System
Worst Mode	<input checked="" type="checkbox"/> Mode 1 <input type="checkbox"/> Mode 2 <input type="checkbox"/> Mode 3 <input type="checkbox"/> Mode 4

Remark:

1. The worst mode was record in this test report.
2. EUT pre-scanned in three axis ,X,Y, Z and two polarity, for radiated measurement. The worst case(X-Plane) were recorded in this report

Report No.: TMWK2207002918KR

3.3 EUT DUTY CYCLE

Temperature: 26.6°C

Test date: July 29, 2022

Humidity: 53% RH

Tested by: David Li

For GFSK (1Mbps)

Duty Cycle				
Configuration	Duty Cycle (%) = Ton / (Ton+Toff)	Duty Factor (dB) =10*log (1/Duty Cycle)	1/T (kHz)	VBW setting (kHz)
DH1	31.20	5.06	2.56	3.00
DH3	43.73	3.59	0.61	1.00
DH5	76.80	1.15	0.35	1.00

For 8-DPSK (3Mbps)

Duty Cycle				
Configuration	Duty Cycle (%) = Ton / (Ton+Toff)	Duty Factor (dB) =10*log (1/Duty Cycle)	1/T (kHz)	VBW setting (kHz)
3DH1	30.80	5.11	2.60	3.00
3DH3	43.73	3.59	0.61	1.00
3DH5	77.60	1.10	0.34	1.00

Report No.: TMWK2207002918KR

For GFSK (1Mbps)



Report No.: TMWK2207002918KR

For 8-DPSK (3Mbps)

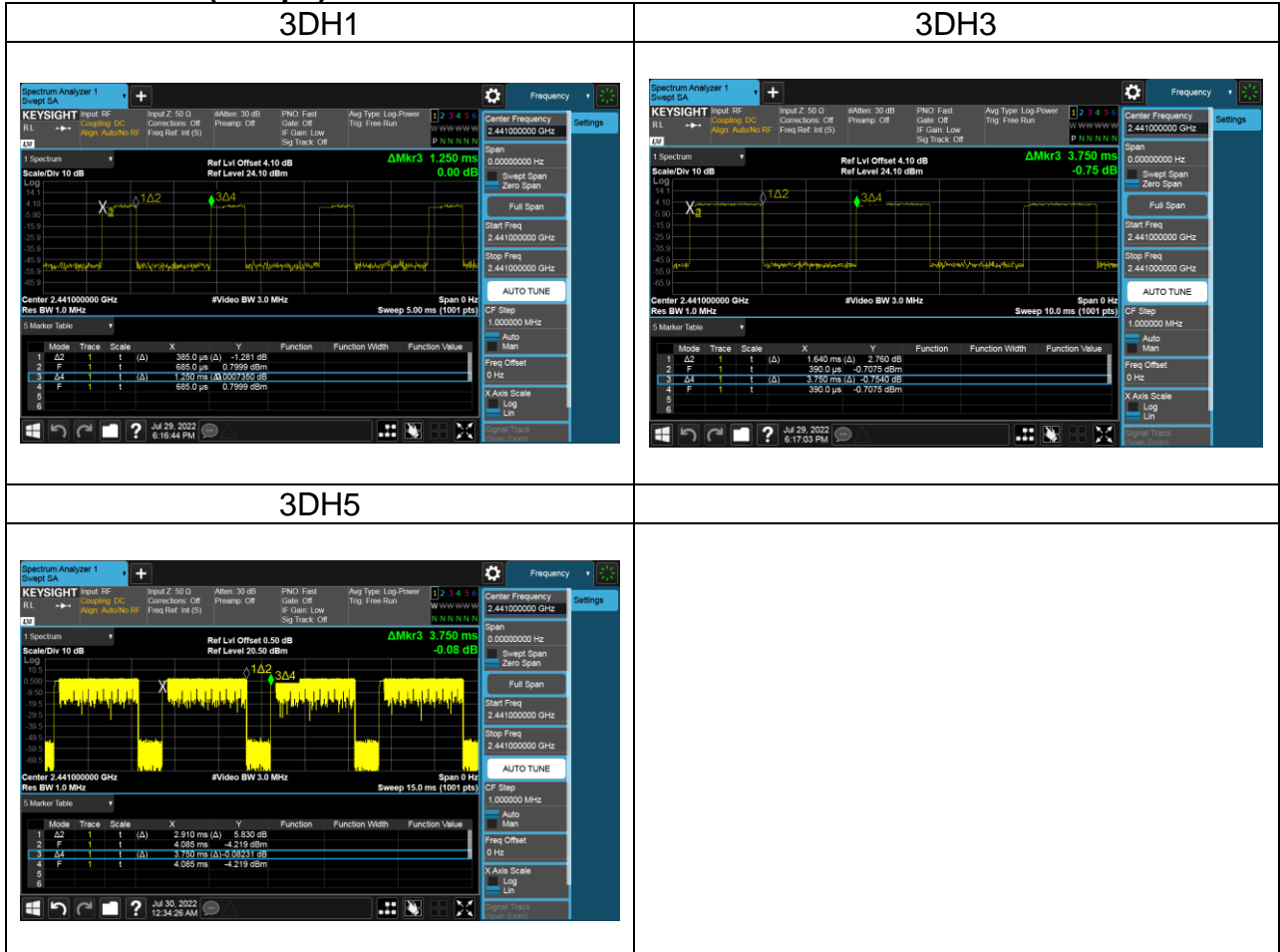

Report No.: TMWK2207002918KR

4. TEST RESULT

4.1 AC POWER LINE CONDUCTED EMISSION

4.1.1 Test Limit

According to §15.207(a),

Frequency Range (MHz)	Limits(dB μ V)	
	Quasi-peak	Average
0.15 to 0.50	66 to 56*	56 to 46*
0.50 to 5	56	46
5 to 30	60	50

* Decreases with the logarithm of the frequency.

4.1.2 Test Procedure

Test method Refer as ANSI C63.10: 2013 clause 6.2,

1. The EUT was placed on a non-conducted table, which is 0.8m above horizontal ground plane and 0.4m above vertical ground plane.
2. EUT connected to the line impedance stabilization network (LISN)
3. Receiver set RBW of 9kHz and Detector Peak, and note as quasi-peak and average.
4. Maximum procedure was performed on the six highest emissions to ensure EUT compliance.
5. Recorded Line for Neutral and Line.

4.1.3 Test Setup

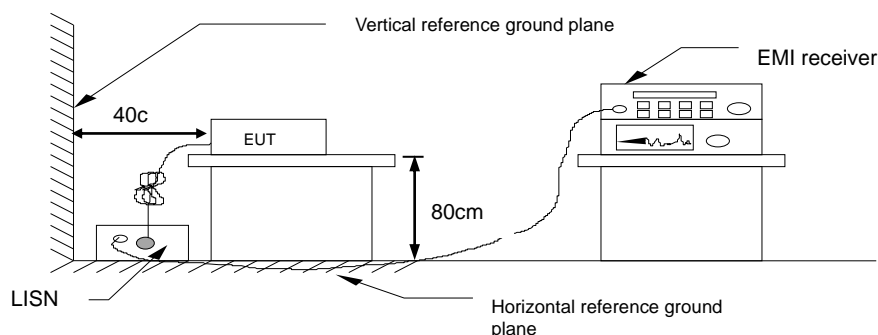

4.1.4 Test Result

Pass.

Test Data

Test Mode:	BT BR-1%	Temp/Hum	25.9(°C)/ 50%RH
Phase:	Line	Test Date	August 10, 2022
Test Voltage:	120Vac, 60Hz	Test Engineer	Tony Chao

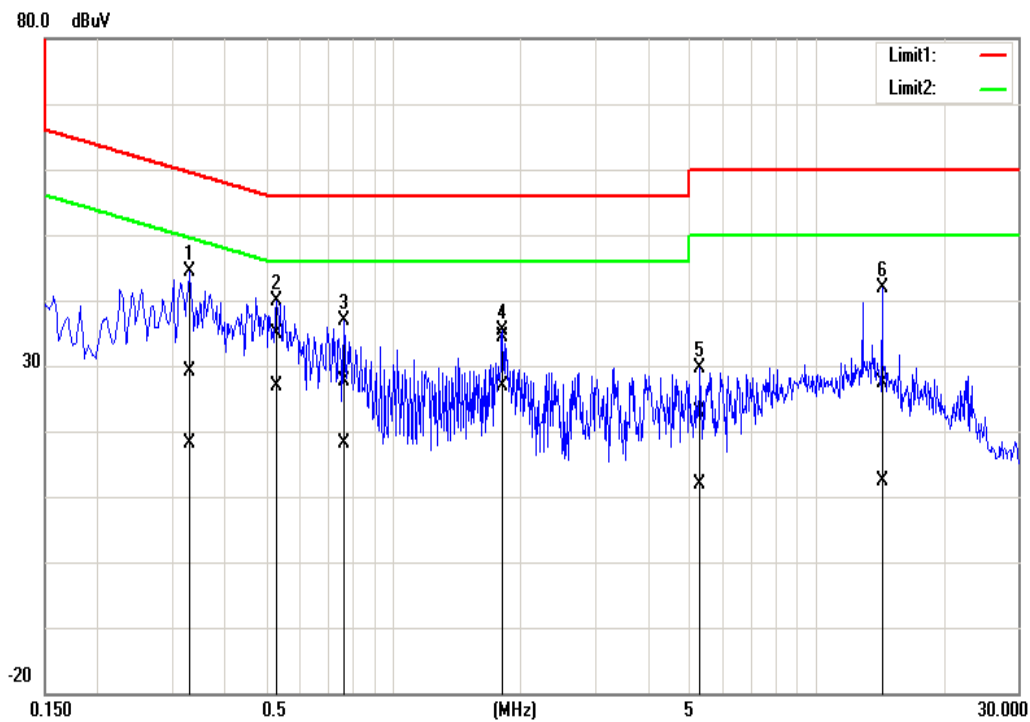

Frequency (MHz)	Quasi Peak reading (dBuV)	Average reading (dBuV)	Correction factor (dB)	Quasi Peak result (dBuV)	Average result (dBuV)	Quasi Peak limit (dBuV)	Average limit (dBuV)	Quasi Peak margin (dB)	Average margin (dB)	Remark
0.3300	18.91	8.06	10.19	29.10	18.25	59.45	49.45	-30.35	-31.20	Pass
0.5300	24.58	16.62	10.19	34.77	26.81	56.00	46.00	-21.23	-19.19	Pass
0.7660	17.46	7.81	10.21	27.67	18.02	56.00	46.00	-28.33	-27.98	Pass
1.8100	24.04	16.52	10.25	34.29	26.77	56.00	46.00	-21.71	-19.23	Pass
5.3180	12.52	1.47	10.32	22.84	11.79	60.00	50.00	-37.16	-38.21	Pass
14.3460	17.07	2.13	10.36	27.43	12.49	60.00	50.00	-32.57	-37.51	Pass

Note: Correction factor = LISN loss + Cable loss.

Report No.: TMWK2207002918KR

Test Mode:	BT BR-1%	Temp/Hum	25.9(°C)/ 50%RH
Phase:	Neutral	Test Date	August 10, 2022
Test Voltage:	120Vac, 60Hz	Test Engineer	Tony Chao

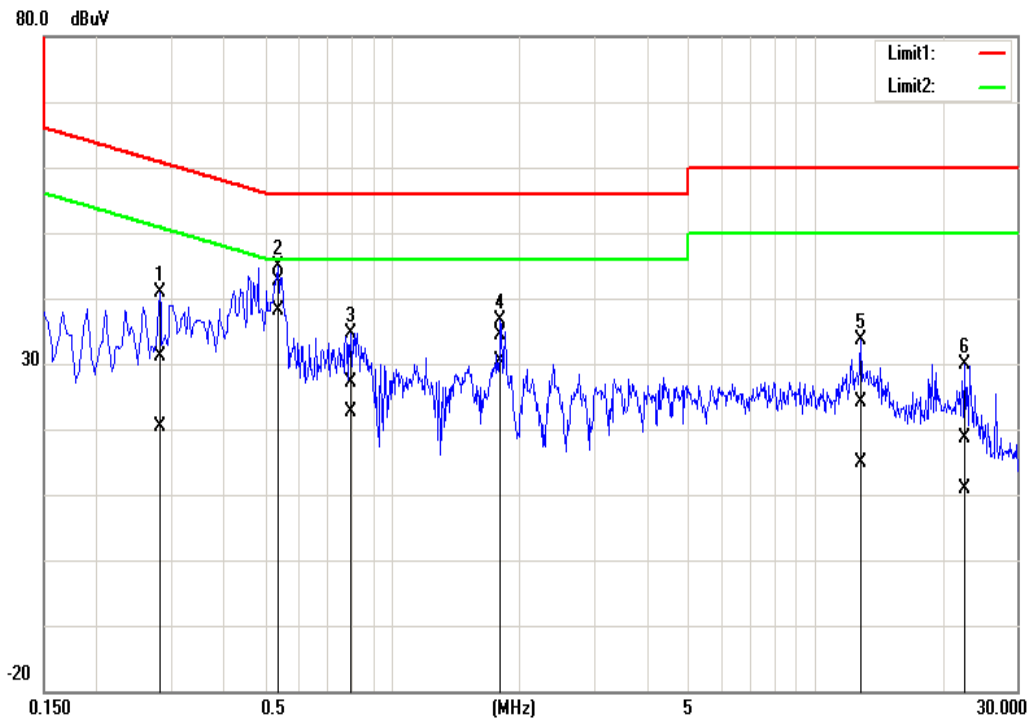

Frequency (MHz)	Quasi Peak reading (dBuV)	Average reading (dBuV)	Correction factor (dB)	Quasi Peak result (dBuV)	Average result (dBuV)	Quasi Peak limit (dBuV)	Average limit (dBuV)	Quasi Peak margin (dB)	Average margin (dB)	Remark
0.2820	21.01	10.13	10.17	31.18	20.30	60.76	50.76	-29.58	-30.46	Pass
0.5380	32.34	27.96	10.18	42.52	38.14	56.00	46.00	-13.48	-7.86	Pass
0.7980	17.02	12.41	10.20	27.22	22.61	56.00	46.00	-28.78	-23.39	Pass
1.8020	24.20	20.03	10.23	34.43	30.26	56.00	46.00	-21.57	-15.74	Pass
12.7900	13.71	4.48	10.37	24.08	14.85	60.00	50.00	-35.92	-35.15	Pass
22.5660	8.18	0.49	10.46	18.64	10.95	60.00	50.00	-41.36	-39.05	Pass

Note: Correction factor = LISN loss + Cable loss.

Report No.: TMWK2207002918KR

Test Mode:	BT BR -50%	Temp/Hum	25.9(°C)/ 50%RH
Phase:	Line	Test Date	August 10, 2022
Test Voltage:	120Vac, 60Hz	Test Engineer	Tony Chao

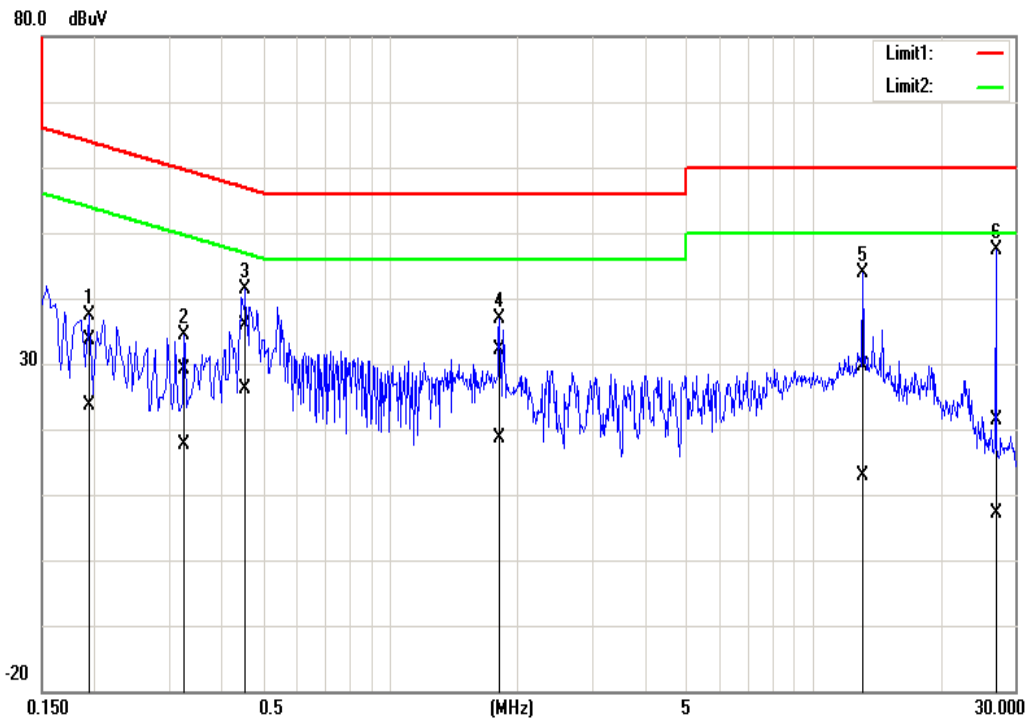

Frequency (MHz)	Quasi Peak reading (dBuV)	Average reading (dBuV)	Correction factor (dB)	Quasi Peak result (dBuV)	Average result (dBuV)	Quasi Peak limit (dBuV)	Average limit (dBuV)	Quasi Peak margin (dB)	Average margin (dB)	Remark
0.1940	23.40	13.37	10.18	33.58	23.55	63.86	53.86	-30.28	-30.31	Pass
0.3260	18.94	7.45	10.19	29.13	17.64	59.55	49.55	-30.42	-31.91	Pass
0.4540	25.74	15.93	10.19	35.93	26.12	56.80	46.80	-20.87	-20.68	Pass
1.8180	21.96	8.31	10.25	32.21	18.56	56.00	46.00	-23.79	-27.44	Pass
13.1260	19.35	2.56	10.36	29.71	12.92	60.00	50.00	-30.29	-37.08	Pass
27.0660	11.13	-3.07	10.15	21.28	7.08	60.00	50.00	-38.72	-42.92	Pass

Note: Correction factor = LISN loss + Cable loss.

Report No.: TMWK2207002918KR

Test Mode:	BT BR -50%	Temp/Hum	25.9(°C)/ 50%RH
Phase:	Neutral	Test Date	August 10, 2022
Test Voltage:	120Vac, 60Hz	Test Engineer	Tony Chao

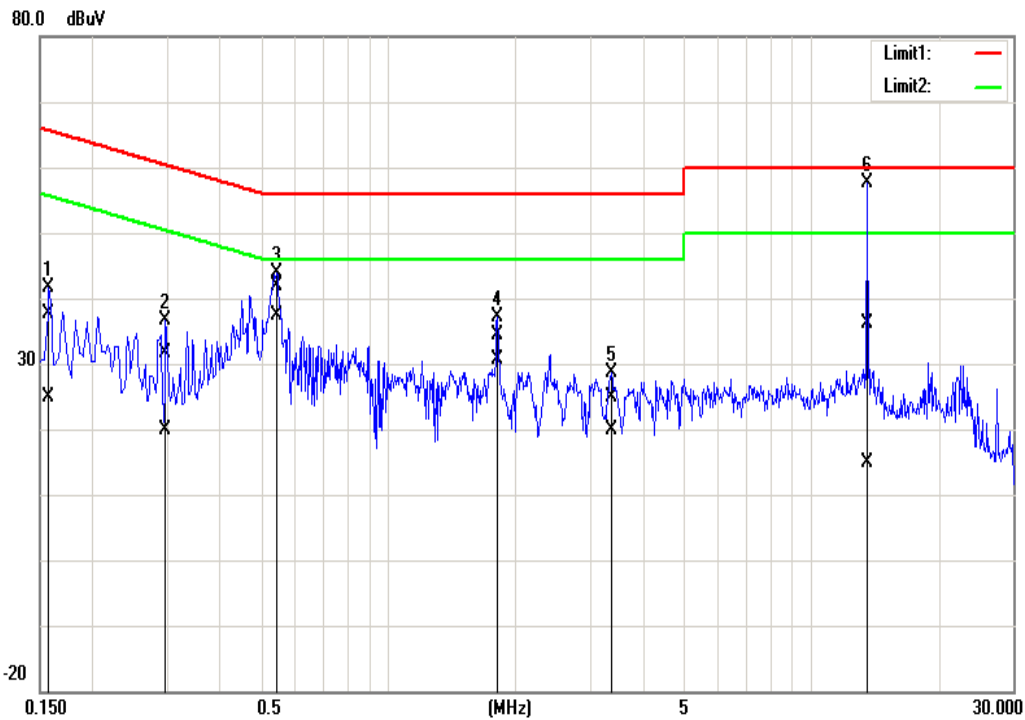

Frequency (MHz)	Quasi Peak reading (dBuV)	Average reading (dBuV)	Correction factor (dB)	Quasi Peak result (dBuV)	Average result (dBuV)	Quasi Peak limit (dBuV)	Average limit (dBuV)	Quasi Peak margin (dB)	Average margin (dB)	Remark
0.1580	27.52	14.78	10.17	37.69	24.95	65.56	55.57	-27.87	-30.62	Pass
0.2980	21.34	9.77	10.17	31.51	19.94	60.30	50.30	-28.79	-30.36	Pass
0.5460	31.59	27.17	10.18	41.77	37.35	56.00	46.00	-14.23	-8.65	Pass
1.8100	24.27	20.42	10.23	34.50	30.65	56.00	46.00	-21.50	-15.35	Pass
3.3700	14.60	9.65	10.26	24.86	19.91	56.00	46.00	-31.14	-26.09	Pass
13.5940	25.67	4.43	10.38	36.05	14.81	60.00	50.00	-23.95	-35.19	Pass

Note: Correction factor = LISN loss + Cable loss.

Report No.: TMWK2207002918KR

Test Mode:	BT BR-99%	Temp/Hum	25.9(°C)/ 50%RH
Phase:	Line	Test Date	August 10, 2022
Test Voltage:	120Vac, 60Hz	Test Engineer	Tony Chao

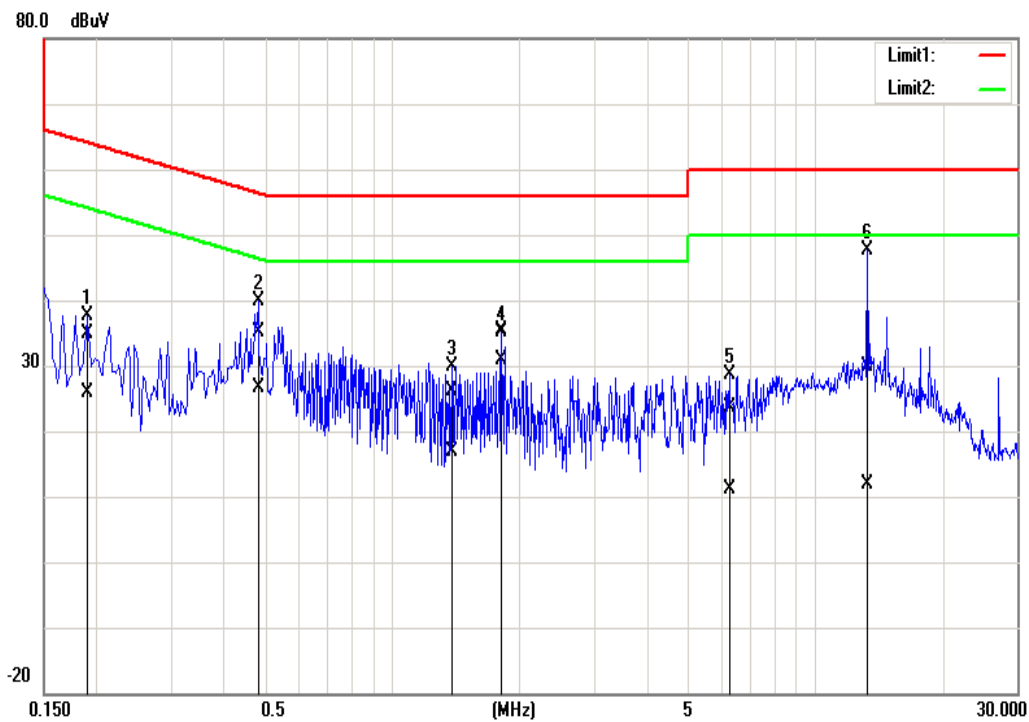

Frequency (MHz)	Quasi Peak reading (dBuV)	Average reading (dBuV)	Correction factor (dB)	Quasi Peak result (dBuV)	Average result (dBuV)	Quasi Peak limit (dBuV)	Average limit (dBuV)	Quasi Peak margin (dB)	Average margin (dB)	Remark
0.1900	24.76	15.77	10.18	34.94	25.95	64.04	54.04	-29.10	-28.09	Pass
0.4820	24.99	16.43	10.19	35.18	26.62	56.30	46.30	-21.12	-19.68	Pass
1.3860	15.99	6.64	10.23	26.22	16.87	56.00	46.00	-29.78	-29.13	Pass
1.8100	25.06	20.72	10.25	35.31	30.97	56.00	46.00	-20.69	-15.03	Pass
6.2660	13.31	0.85	10.32	23.63	11.17	60.00	50.00	-36.37	-38.83	Pass
13.3100	19.49	1.51	10.36	29.85	11.87	60.00	50.00	-30.15	-38.13	Pass

Note: Correction factor = LISN loss + Cable loss.

Report No.: TMWK2207002918KR

Test Mode:	BT BR-99%	Temp/Hum	25.9(°C)/ 50%RH
Phase:	Neutral	Test Date	August 10, 2022
Test Voltage:	120Vac, 60Hz	Test Engineer	Tony Chao

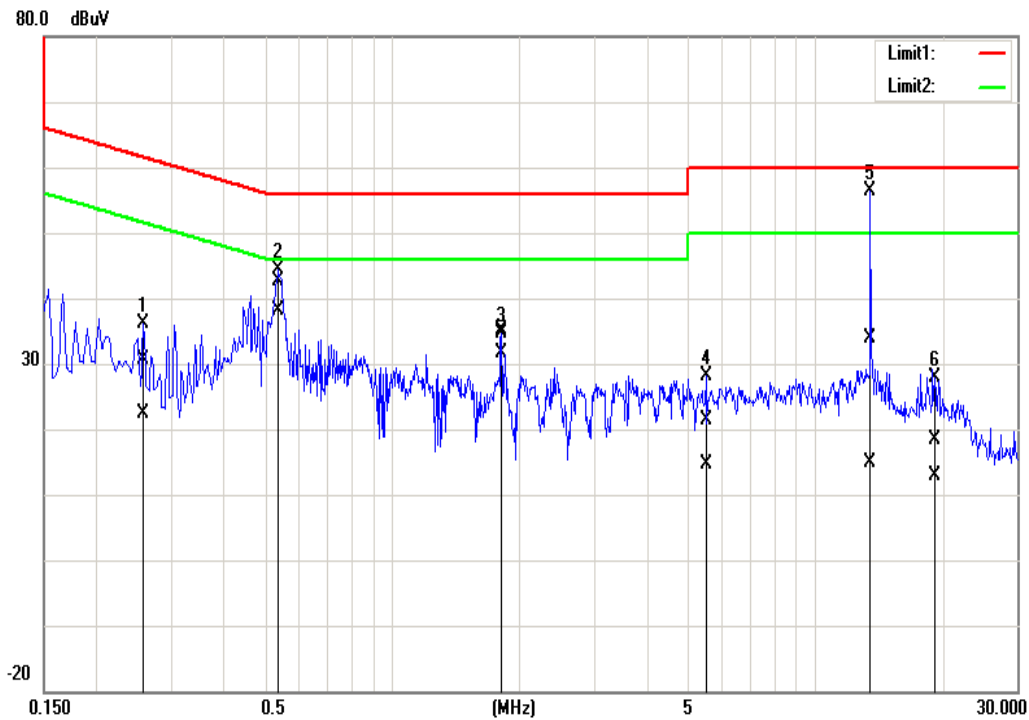

Frequency (MHz)	Quasi Peak reading (dBuV)	Average reading (dBuV)	Correction factor (dB)	Quasi Peak result (dBuV)	Average result (dBuV)	Quasi Peak limit (dBuV)	Average limit (dBuV)	Quasi Peak margin (dB)	Average margin (dB)	Remark
0.2580	20.44	12.10	10.17	30.61	22.27	61.50	51.50	-30.89	-29.23	Pass
0.5380	32.51	28.04	10.18	42.69	38.22	56.00	46.00	-13.31	-7.78	Pass
1.8100	24.96	21.31	10.23	35.19	31.54	56.00	46.00	-20.81	-14.46	Pass
5.5100	10.96	4.39	10.30	21.26	14.69	60.00	50.00	-38.74	-35.31	Pass
13.5300	23.41	4.40	10.37	33.78	14.77	60.00	50.00	-26.22	-35.23	Pass
19.2180	8.01	2.41	10.40	18.41	12.81	60.00	50.00	-41.59	-37.19	Pass

Note: Correction factor = LISN loss + Cable loss.

Report No.: TMWK2207002918KR

Test Mode:	BT EDR-1%	Temp/Hum	25.9(°C)/ 50%RH
Phase:	Line	Test Date	August 10, 2022
Test Voltage:	120Vac, 60Hz	Test Engineer	Tony Chao

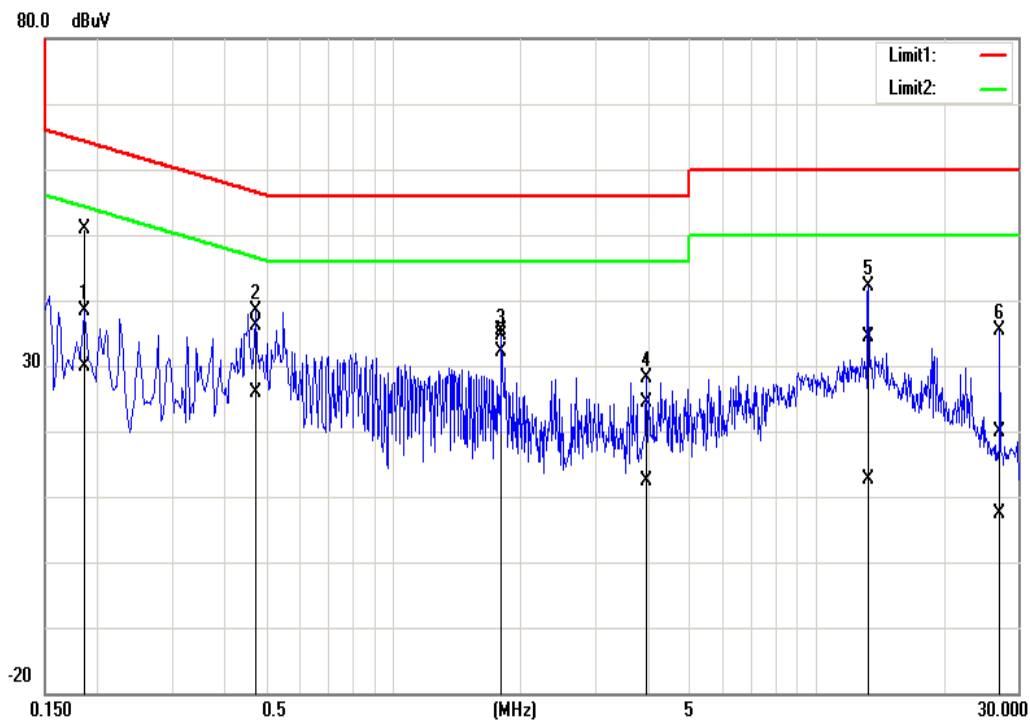

Frequency (MHz)	Quasi Peak reading (dBuV)	Average reading (dBuV)	Correction factor (dB)	Quasi Peak result (dBuV)	Average result (dBuV)	Quasi Peak limit (dBuV)	Average limit (dBuV)	Quasi Peak margin (dB)	Average margin (dB)	Remark
0.1860	40.71	19.78	10.18	50.89	29.96	64.21	54.21	-13.32	-24.25	Pass
0.4740	25.89	15.70	10.19	36.08	25.89	56.44	46.44	-20.36	-20.55	Pass
1.8060	25.14	21.84	10.25	35.39	32.09	56.00	46.00	-20.61	-13.91	Pass
3.9660	13.96	2.09	10.30	24.26	12.39	56.00	46.00	-31.74	-33.61	Pass
13.2700	24.14	2.21	10.36	34.50	12.57	60.00	50.00	-25.50	-37.43	Pass
27.1860	9.77	-2.86	10.15	19.92	7.29	60.00	50.00	-40.08	-42.71	Pass

Note: Correction factor = LISN loss + Cable loss.

Test Mode:	BT EDR-1%	Temp/Hum	25.9(°C)/ 50%RH
Phase:	Neutral	Test Date	August 10, 2022
Test Voltage:	120Vac, 60Hz	Test Engineer	Tony Chao

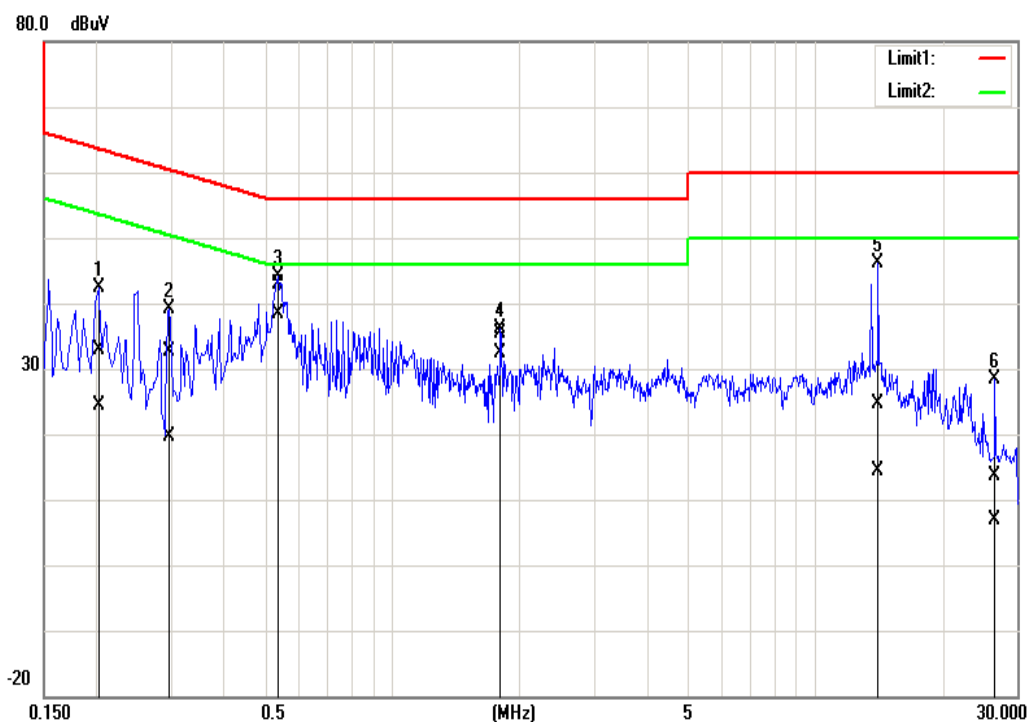

Frequency (MHz)	Quasi Peak reading (dBuV)	Average reading (dBuV)	Correction factor (dB)	Quasi Peak result (dBuV)	Average result (dBuV)	Quasi Peak limit (dBuV)	Average limit (dBuV)	Quasi Peak margin (dB)	Average margin (dB)	Remark
0.2020	22.83	14.19	10.17	33.00	24.36	63.53	53.53	-30.53	-29.17	Pass
0.2980	22.53	9.57	10.17	32.70	19.74	60.30	50.30	-27.60	-30.56	Pass
0.5380	32.67	28.11	10.18	42.85	38.29	56.00	46.00	-13.15	-7.71	Pass
1.8060	25.13	22.13	10.23	35.36	32.36	56.00	46.00	-20.64	-13.64	Pass
14.1140	14.32	4.03	10.38	24.70	14.41	60.00	50.00	-35.30	-35.59	Pass
26.5980	3.17	-3.77	10.53	13.70	6.76	60.00	50.00	-46.30	-43.24	Pass

Note: Correction factor = LISN loss + Cable loss.

Report No.: TMWK2207002918KR

Test Mode:	BT EDR -50%	Temp/Hum	25.9(°C)/ 50%RH
Phase:	Line	Test Date	August 10, 2022
Test Voltage:	120Vac, 60Hz	Test Engineer	Tony Chao

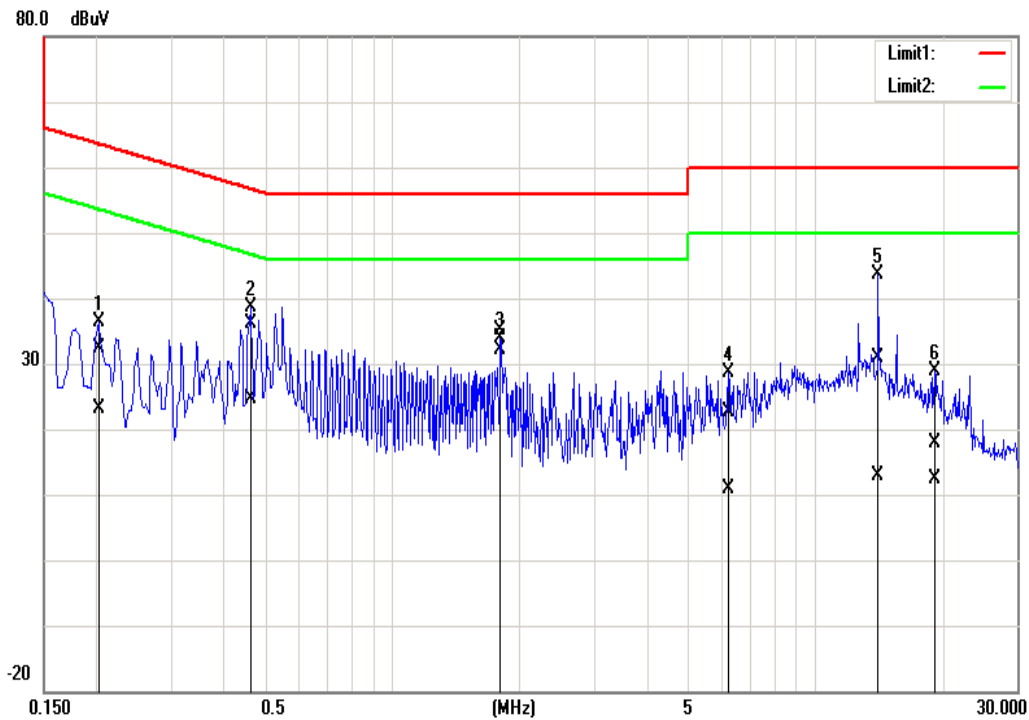

Frequency (MHz)	Quasi Peak reading (dBuV)	Average reading (dBuV)	Correction factor (dB)	Quasi Peak result (dBuV)	Average result (dBuV)	Quasi Peak limit (dBuV)	Average limit (dBuV)	Quasi Peak margin (dB)	Average margin (dB)	Remark
0.2020	22.32	13.06	10.18	32.50	23.24	63.53	53.53	-31.03	-30.29	Pass
0.4620	26.05	14.44	10.19	36.24	24.63	56.66	46.66	-20.42	-22.03	Pass
1.8060	24.92	21.76	10.25	35.17	32.01	56.00	46.00	-20.83	-13.99	Pass
6.2380	12.38	0.61	10.32	22.70	10.93	60.00	50.00	-37.30	-39.07	Pass
14.1260	20.63	2.39	10.37	31.00	12.76	60.00	50.00	-29.00	-37.24	Pass
19.1380	7.48	2.01	10.37	17.85	12.38	60.00	50.00	-42.15	-37.62	Pass

Note: Correction factor = LISN loss + Cable loss.

Test Mode:	BT EDR -50%	Temp/Hum	25.9(°C)/ 50%RH
Phase:	Neutral	Test Date	August 10, 2022
Test Voltage:	120Vac, 60Hz	Test Engineer	Tony Chao

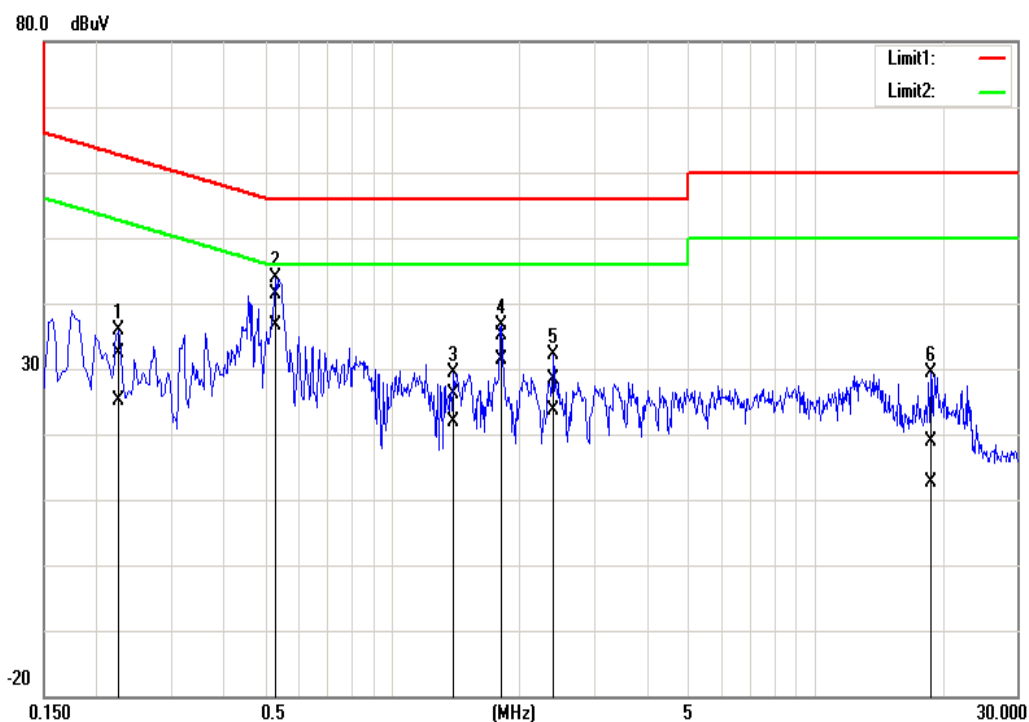

Frequency (MHz)	Quasi Peak reading (dBuV)	Average reading (dBuV)	Correction factor (dB)	Quasi Peak result (dBuV)	Average result (dBuV)	Quasi Peak limit (dBuV)	Average limit (dBuV)	Quasi Peak margin (dB)	Average margin (dB)	Remark
0.2260	22.19	14.96	10.17	32.36	25.13	62.60	52.60	-30.24	-27.47	Pass
0.5300	31.22	26.34	10.18	41.40	36.52	56.00	46.00	-14.60	-9.48	Pass
1.4020	15.84	11.58	10.21	26.05	21.79	56.00	46.00	-29.95	-24.21	Pass
1.8100	24.95	21.11	10.23	35.18	31.34	56.00	46.00	-20.82	-14.66	Pass
2.4060	18.10	13.40	10.24	28.34	23.64	56.00	46.00	-27.66	-22.36	Pass
18.8020	8.57	2.23	10.40	18.97	12.63	60.00	50.00	-41.03	-37.37	Pass

Note: Correction factor = LISN loss + Cable loss.

Test Mode:	BT EDR-99%	Temp/Hum	25.9(°C)/ 50%RH
Phase:	Line	Test Date	August 10, 2022
Test Voltage:	120Vac, 60Hz	Test Engineer	Tony Chao

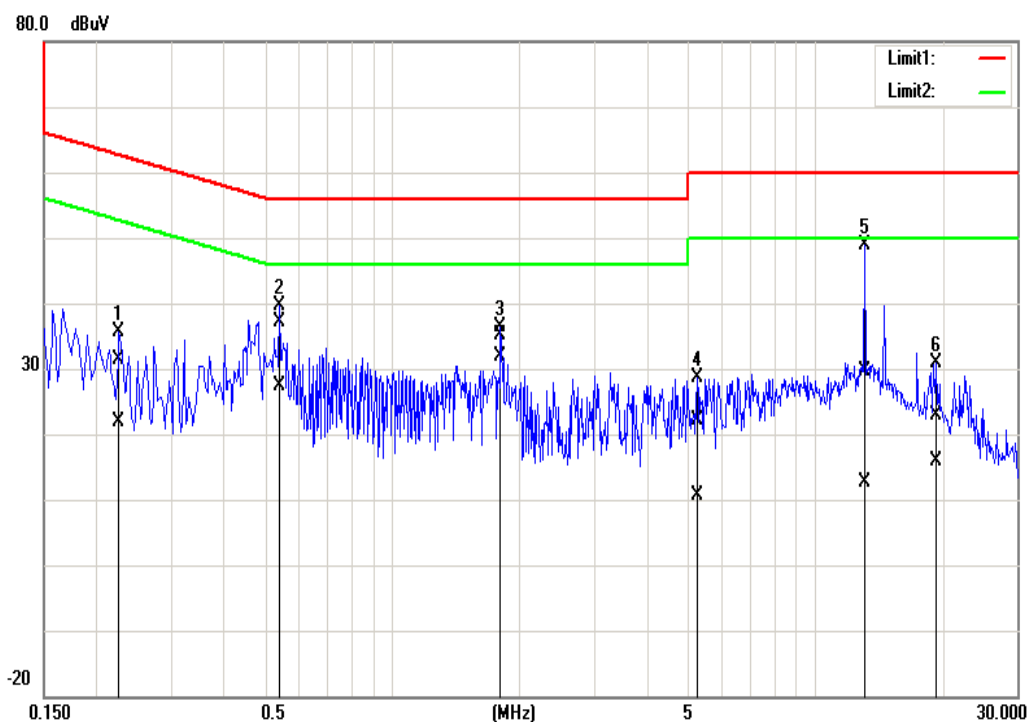

Frequency (MHz)	Quasi Peak reading (dBuV)	Average reading (dBuV)	Correction factor (dB)	Quasi Peak result (dBuV)	Average result (dBuV)	Quasi Peak limit (dBuV)	Average limit (dBuV)	Quasi Peak margin (dB)	Average margin (dB)	Remark
0.2260	21.21	11.65	10.18	31.39	21.83	62.60	52.60	-31.21	-30.77	Pass
0.5420	26.93	17.25	10.19	37.12	27.44	56.00	46.00	-18.88	-18.56	Pass
1.8060	24.88	21.71	10.25	35.13	31.96	56.00	46.00	-20.87	-14.04	Pass
5.2620	11.74	0.20	10.32	22.06	10.52	60.00	50.00	-37.94	-39.48	Pass
13.0740	19.25	2.34	10.36	29.61	12.70	60.00	50.00	-30.39	-37.30	Pass
19.3940	12.40	5.58	10.37	22.77	15.95	60.00	50.00	-37.23	-34.05	Pass

Note: Correction factor = LISN loss + Cable loss.

Report No.: TMWK2207002918KR

Test Mode:	BT EDR-99%	Temp/Hum	24.3(°C)/ 52%RH
Phase:	Neutral	Test Date	August 16, 2022
Test Voltage:	120Vac, 60Hz	Test Engineer	Tony Chao

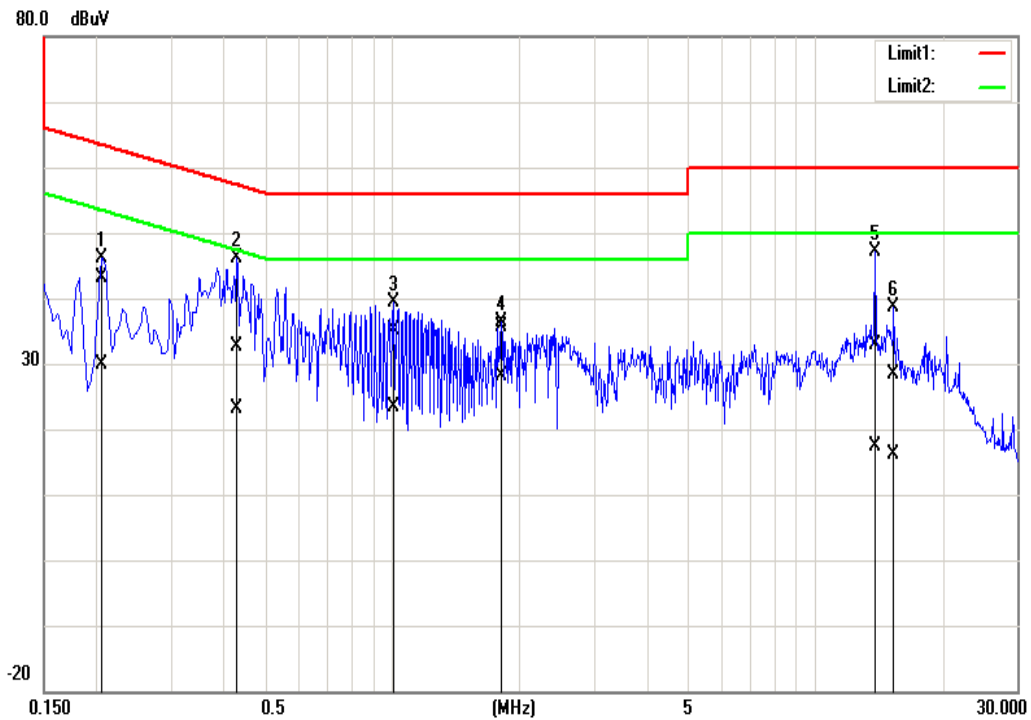

Frequency (MHz)	Quasi Peak reading (dBuV)	Average reading (dBuV)	Correction factor (dB)	Quasi Peak result (dBuV)	Average result (dBuV)	Quasi Peak limit (dBuV)	Average limit (dBuV)	Quasi Peak margin (dB)	Average margin (dB)	Remark
0.2060	33.00	19.67	10.17	43.17	29.84	63.37	53.37	-20.20	-23.53	Pass
0.4300	22.54	13.05	10.18	32.72	23.23	57.25	47.25	-24.53	-24.02	Pass
1.0100	24.82	13.07	10.20	35.02	23.27	56.00	46.00	-20.98	-22.73	Pass
1.8140	25.46	17.95	10.23	35.69	28.18	56.00	46.00	-20.31	-17.82	Pass
13.8700	22.60	6.98	10.38	32.98	17.36	60.00	50.00	-27.02	-32.64	Pass
15.3260	18.09	5.70	10.38	28.47	16.08	60.00	50.00	-31.53	-33.92	Pass

Note: Correction factor = LISN loss + Cable loss.

Report No.: TMWK2207002918KR

4.2 20dB BANDWIDTH AND OCCUPIED BANDWIDTH (99%)

4.2.1 Test Limit

According to §15.247(a) (1)

20 dB Bandwidth : For reporting purposes only.

Occupied Bandwidth(99%) : For reporting purposes only.

4.2.2 Test Procedure

Test method Refer as ANSI C63.10: 2013 clause 7.8.7,

1. The EUT RF output connected to the spectrum analyzer by RF cable.
2. Setting maximum power transmit of EUT
3. SA set RBW = 1% ~ 5% OBW, VBW $\geq 3 \times$ RBW and Detector = Peak, to measurement 20 dB Bandwidth.
4. SA set RBW = 1% ~ 5% OBW, VBW \geq three times the RBW and Detector = Peak, to measurement 99% Bandwidth
5. Measure and record the result of 20 dB Bandwidth and 99% Bandwidth. in the test report.

4.2.3 Test Setup

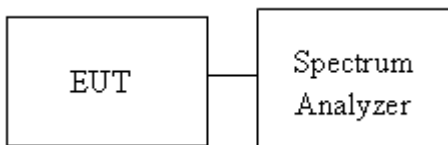

4.2.4 Test Result

Temperature: 26.6°C

Test date: July 29, 2022

Humidity: 53% RH

Tested by: David Li

Test mode: GFSK_BDR-1Mbps mode / 2402-2480 MHz			
Channel	Frequency (MHz)	OBW(99%) (MHz)	20dB BW (MHz)
Low	2402	0.84782	0.9506
Mid	2441	0.84924	0.9473
High	2480	0.84637	0.9490

Test mode: 8DPSK_EDR-3Mbps mode / 2402-2480 MHz			
Channel	Frequency (MHz)	OBW(99%) (MHz)	20dB BW (MHz)
Low	2402	1.1718	1.292
Mid	2441	1.1723	1.291
High	2480	1.1749	1.291

Report No.: TMWK2207002918KR

Test Data

20dB BANDWIDTH

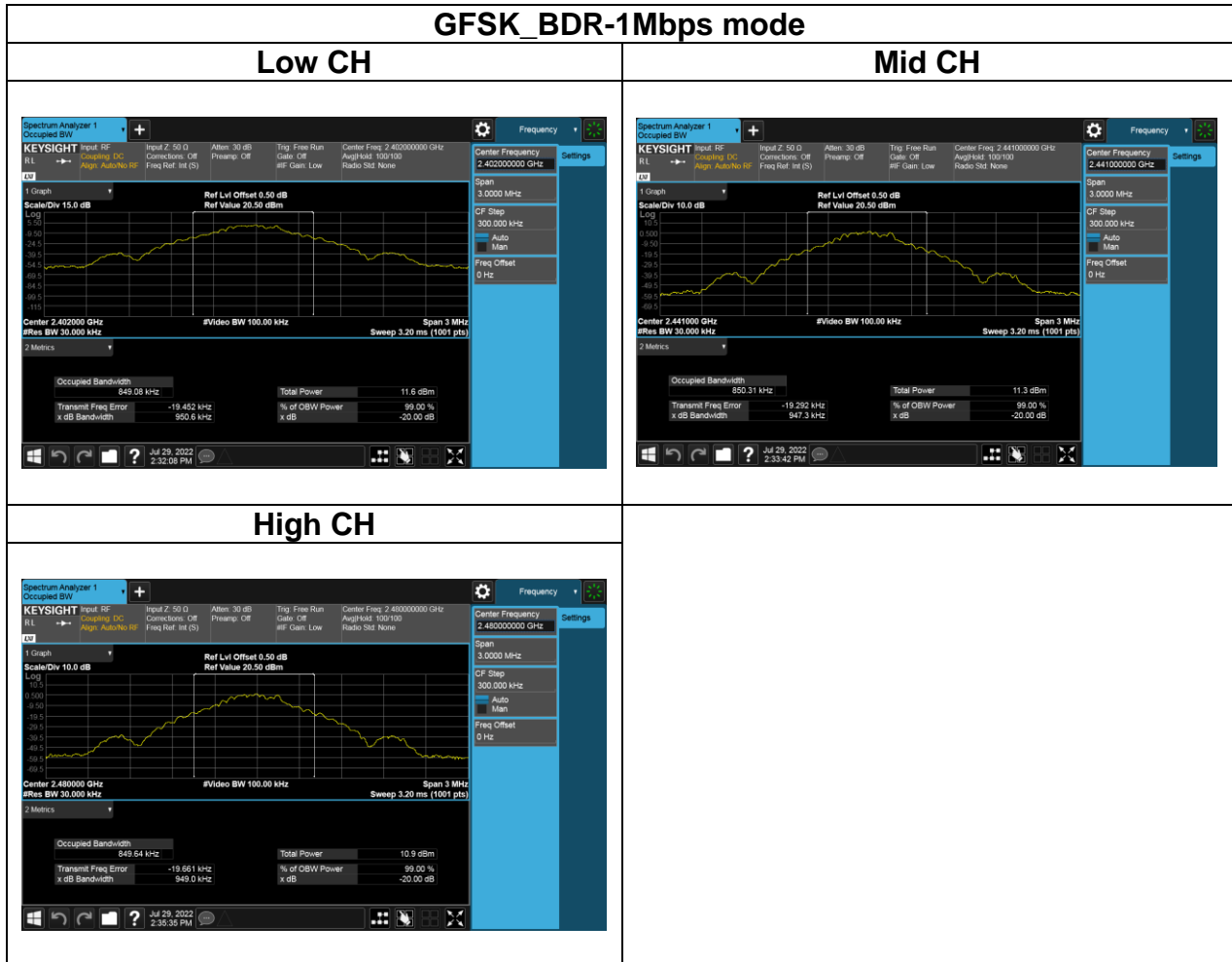

Report No.: TMWK2207002918KR

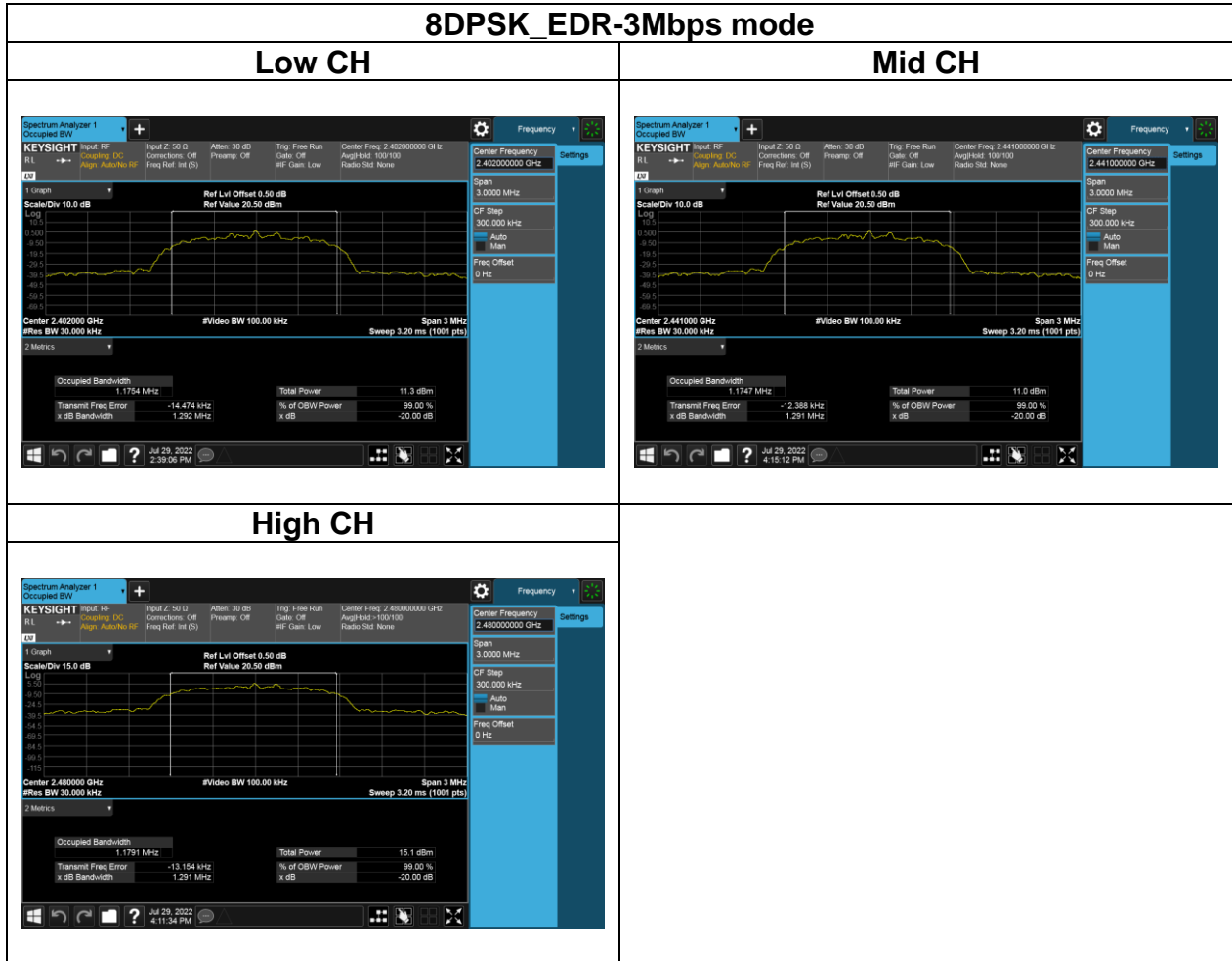

Report No.: TMWK2207002918KR

Test Data

BANDWIDTH 99%

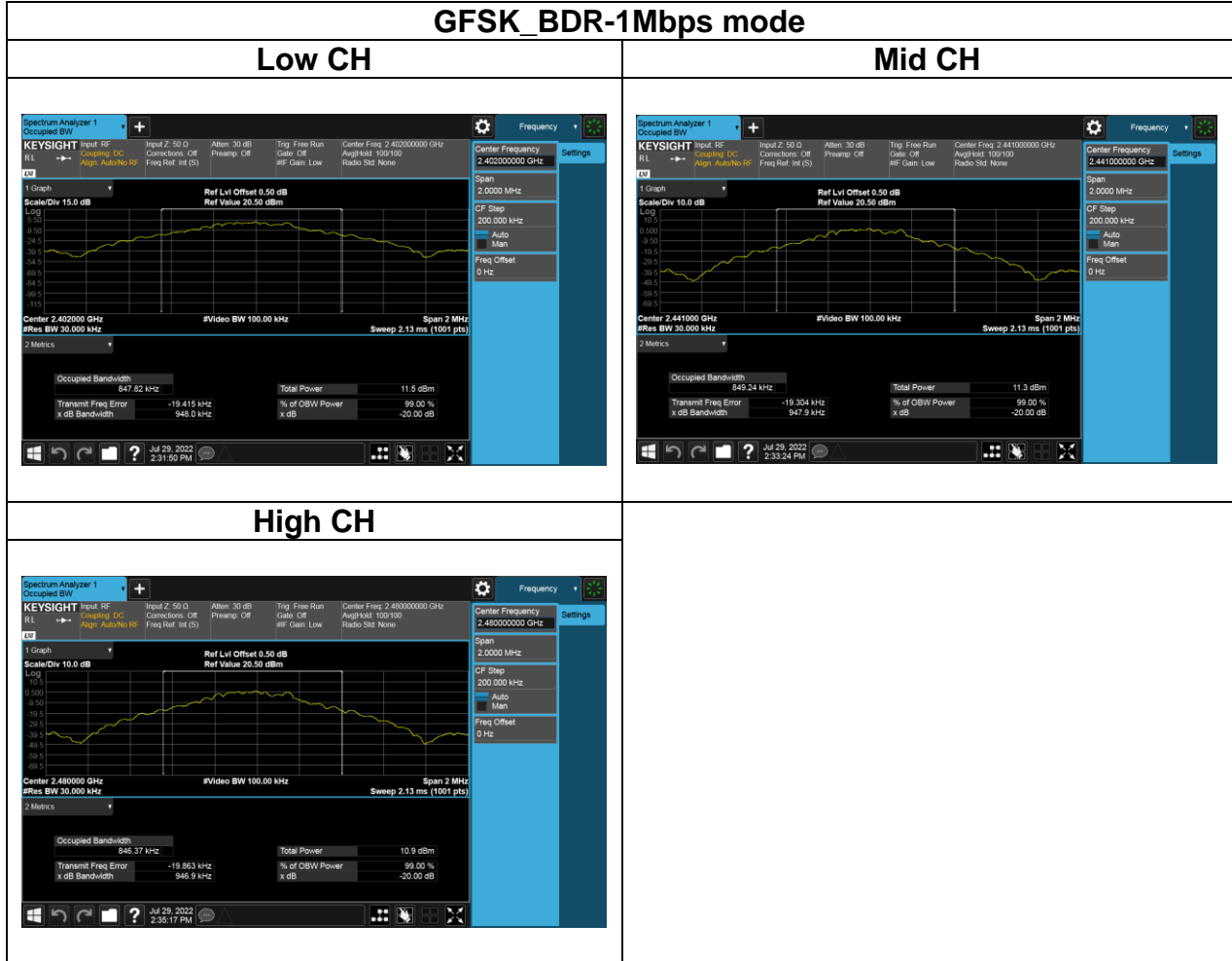

Report No.: TMWK2207002918KR

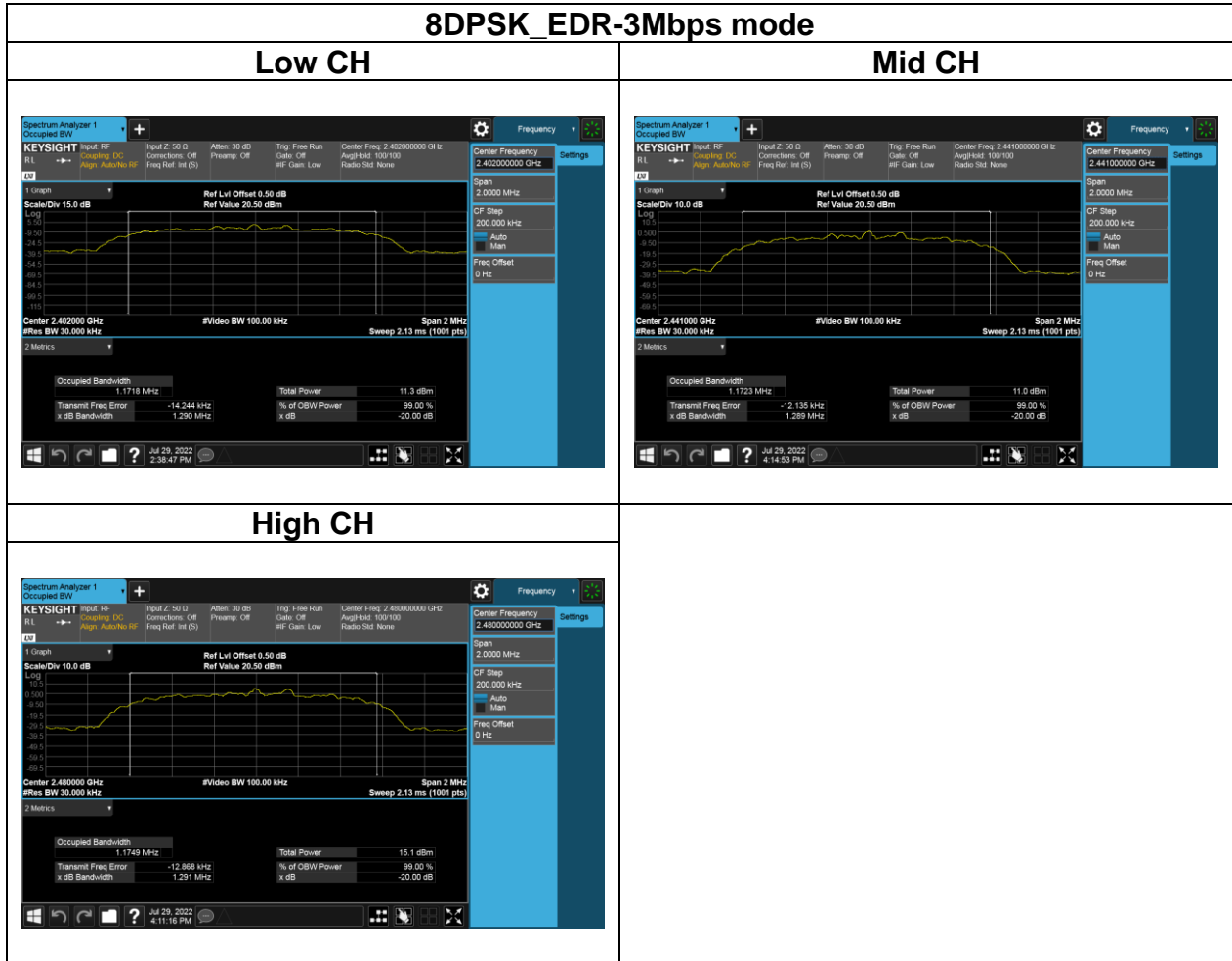

Report No.: TMWK2207002918KR

4.3 OUTPUT POWER MEASUREMENT

4.3.1 Test Limit

According to §15.247(a)(1),

Peak output power :

FCC

Alternatively, frequency hopping systems operating in the 2400-2483.5 MHz band may have hopping channel carrier frequencies that are separated by 25 kHz or two-thirds of the 20 dB bandwidth of the hopping channel, whichever is greater, provided the systems operate with an output power no greater than 125 mW.

Limit	<input checked="" type="checkbox"/> Antenna not exceed 6 dBi : 21dBm <input type="checkbox"/> Antenna with DG greater than 6 dBi : 21dBm [Limit = 30 – (DG – 6)]
-------	--

Average output power : For reporting purposes only.

4.3.2 Test Procedure

1. The EUT RF output connected to the power meter by RF cable.
2. Setting maximum power transmit of EUT.
3. The path loss was compensated to the results for each measurement.
4. Measure and record the result of Peak output power and Average output power. in the test report.

4.3.3 Test Setup

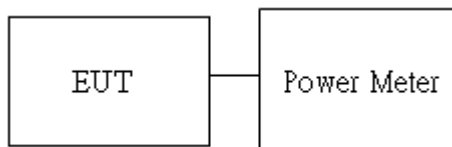

Report No.: TMWK2207002918KR

4.3.4 Test Result

Temperature: 26.6°C

Test date: July 29, 2022

Humidity: 53% RH

Tested by: David Li

Peak output power :

1M BR mode (Peak):

CH	Freq. (MHz)	Power set	Peak Output Power (dBm)	Output Power (mW)	Limit (mW)
Low	2402	5	4.85	3.055	125
Mid	2441	5	4.65	2.917	125
High	2480	5	4.98	3.148	125

3M EDR mode (Peak):

CH	Freq. (MHz)	Power set	Peak Output Power (dBm)	Output Power (mW)	Limit (mW)
Low	2402	7	5.97	3.954	125
Mid	2441	7	5.77	3.776	125
High	2480	8	6.28	4.246	125

Average output power :

1M BR mode (Average):

CH	Freq. (MHz)	Power set	Max. Avg. Output Power (dBm)	Output Power (mW)	Limit (mW)
Low	2402	5	3.57	2.273	125
Mid	2441	5	3.49	2.232	125
High	2480	5	3.71	2.348	125

3M EDR mode (Average):

CH	Freq. (MHz)	Power set	Max. Avg. Output Power (dBm)	Output Power (mW)	Limit (mW)
Low	2402	7	3.30	2.139	125
Mid	2441	7	3.12	2.052	125
High	2480	8	3.51	2.245	125

Report No.: TMWK2207002918KR

4.4 FREQUENCY SEPARATION

4.4.1 Test Limit

According to §15.247(a)(1)

Alternatively, frequency hopping systems operating in the 2400-2483.5 MHz band may have hopping channel carrier frequencies that are separated by 25 kHz or two-thirds of the 20 dB bandwidth of the hopping channel, whichever is greater, provided the systems operate with an output power no greater than 125 mW.

Limit	> two-thirds of the 20 dB bandwidth
-------	-------------------------------------

4.4.2 Test Procedure

1. Place the EUT on the table and set it in transmitting mode.
2. EUT RF output port connected to the SA by RF cable.
3. Set the spectrum analyzer as RBW = 300kHz, VBW = 300kHz, Sweep = auto.
Max hold, mark 3 peaks of hopping channel and record the 3 peaks frequency

4.4.3 Test Setup

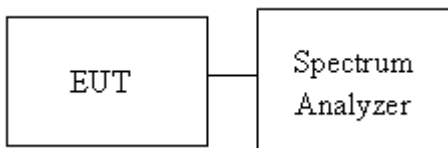

Report No.: TMWK2207002918KR

4.4.4 Test Result

Temperature: 26.6°C

Test date: July 29, 2022

Humidity: 53% RH

Tested by: David Li

Test mode: GFSK_BDR-1Mbps mode / 2402-2480 MHz				
Channel	Frequency (MHz)	Channel Separation (MHz)	Channel Separation Limits (MHz)	Result
Low	2402	1.000	0.63	PASS
Mid	2441	1.000	0.63	PASS
High	2480	1.000	0.63	PASS

Test mode: 8DPSK_EDR-3Mbps mode / 2402-2480 MHz				
Channel	Frequency (MHz)	Channel Separation (MHz)	Channel Separation Limits (MHz)	Result
Low	2402	1.000	0.86	PASS
Mid	2441	1.000	0.86	PASS
High	2480	1.000	0.86	PASS

Report No.: TMWK2207002918KR

Test Data

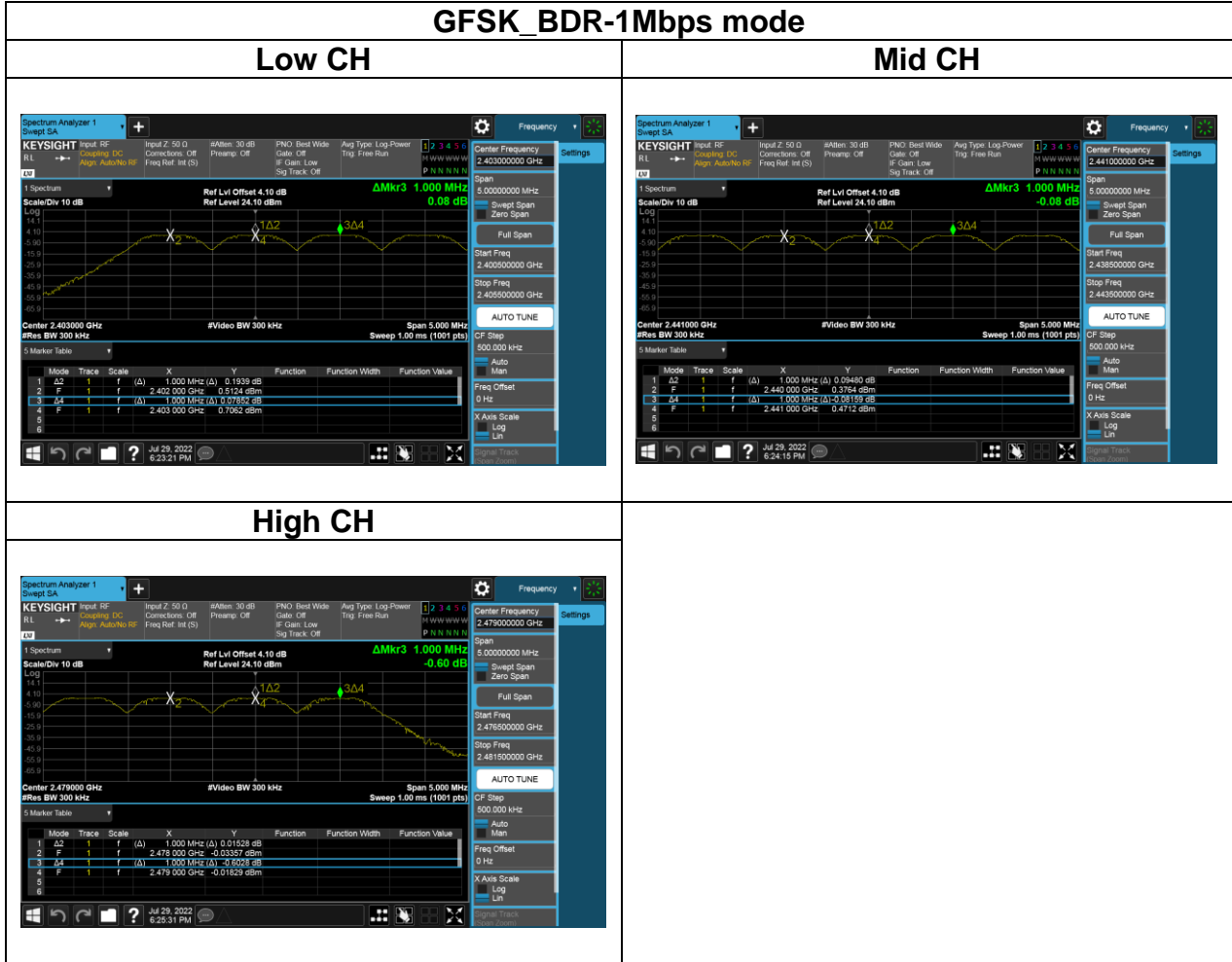

Report No.: TMWK2207002918KR



Report No.: TMWK2207002918KR

4.5 NUMBER OF HOPPING

4.5.1 Test Limit

According to §15.247(a)(1)(iii)

Frequency hopping systems in the 2400-2483.5 MHz band shall use at least 15 channels.

4.5.2 Test Procedure

Test method Refer as ANSI C63.10: 2013 clause 7.8.3

1. Place the EUT on the table and set it in transmitting mode.
2. EUT RF output port connected to the SA by RF cable.
3. Set spectrum analyzer Start Freq. = 2400 MHz, Stop Freq. = 2441 MHz for Low range, Start Freq. = 2441 MHz, Stop Freq. = 2483.5 MHz for High range ; RBW=430KHz, VBW = 1.5MHz.
4. Max hold, view and count how many channel in the band.

4.5.3 Test Setup

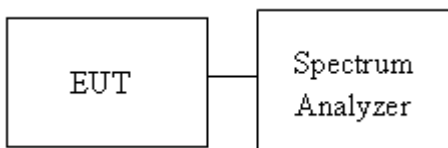

Report No.: TMWK2207002918KR

4.5.4 Test Result

Temperature: 26.6°C

Test date: July 29, 2022

Humidity: 53% RH

Tested by: David Li

Number of Hopping				
Mode	Frequency (MHz)	Hopping Channel Number	Hopping Channel Number Limits	Result
BDR-1Mbps	2402-2480	79	15	Pass
EDR-3Mbps	2402-2480	79	15	

Report No.: TMWK2207002918KR

Test Data

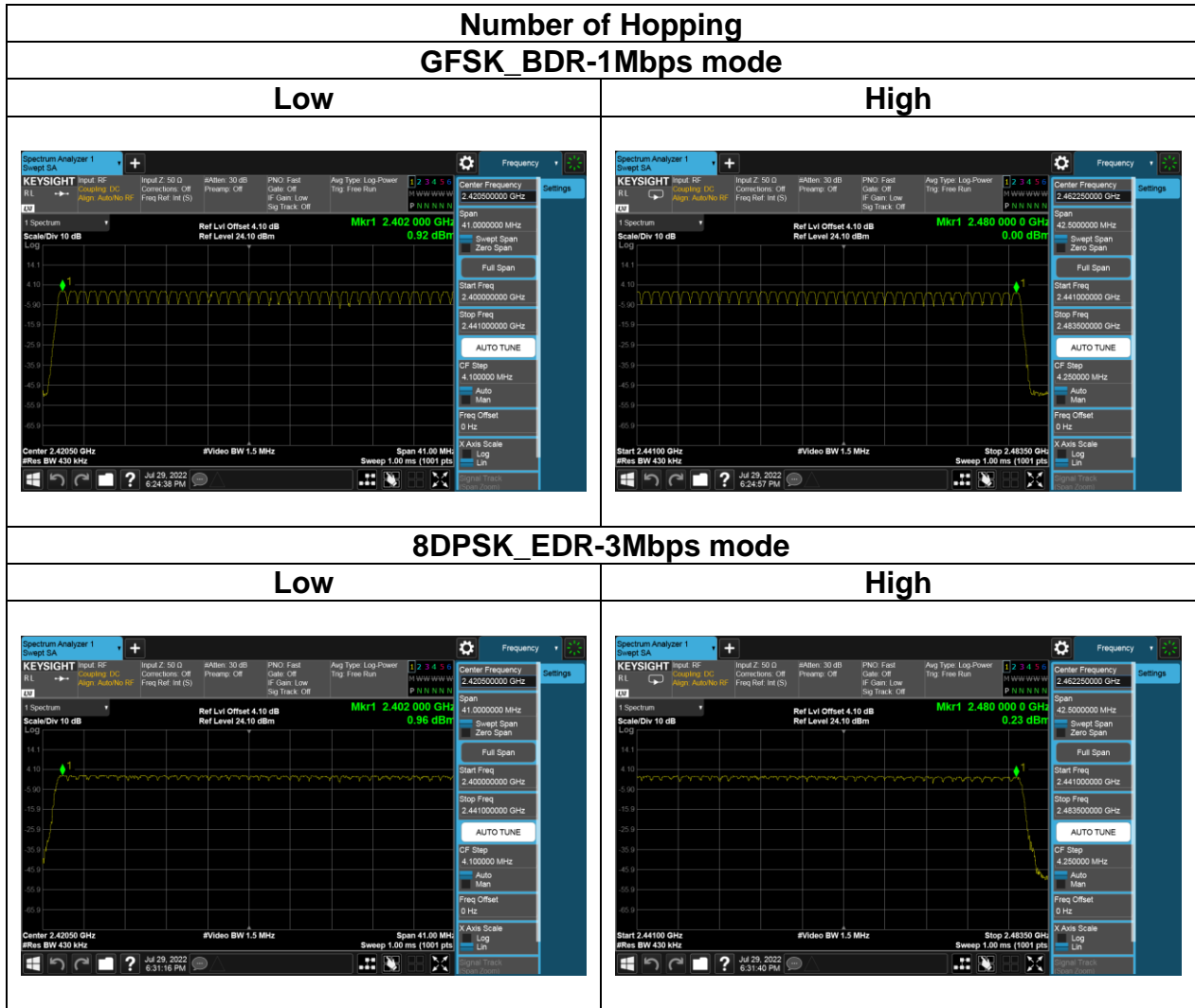

Report No.: TMWK2207002918KR

4.6 CONDUCTED BANDEDGE AND SPURIOUS EMISSION

4.6.1 Test Limit

According to §15.247(d)

Limit	-20 dBc
-------	---------

4.6.2 Test Procedure

1. EUT RF output port connected to the SA by RF cable, and the path loss was compensated to result.
2. SA setting, RBW=100kHz, VBW=300kHz, Detector=Peak, Trace mode = max hold, SWT = Auto.
3. The Band Edge at 2.4GHz and 2.4835GHz are investigated with both hopping "ON" and "OFF" modes ".

4.6.3 Test Setup

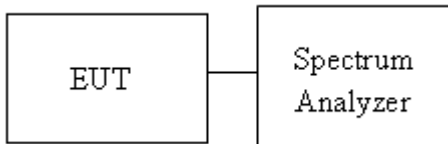

Report No.: TMWK2207002918KR

4.6.4 Test Result

Temperature: 26.6°C

Test date: July 29, 2022

Humidity: 53% RH

Tested by: David Li

Test Data

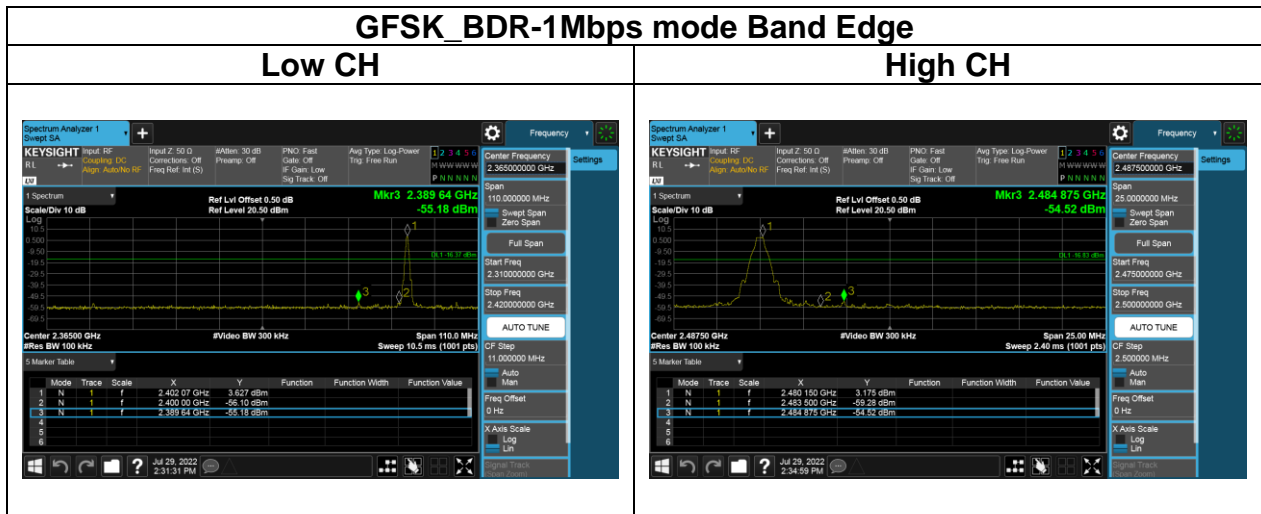

Report No.: TMWK2207002918KR

GFSK_BDR-1Mbps mode Spurious Emission 30MHz-25GHz

Low CH

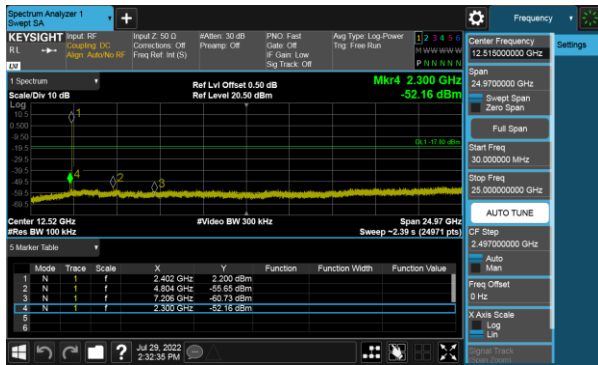

Mid CH

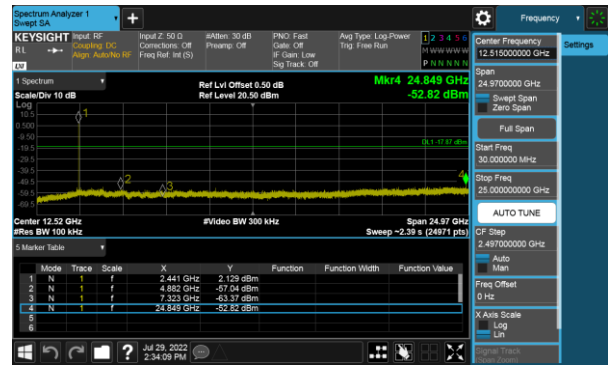

High CH

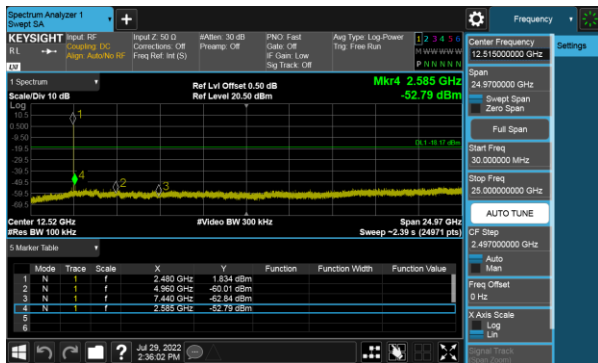

Report No.: TMWK2207002918KR

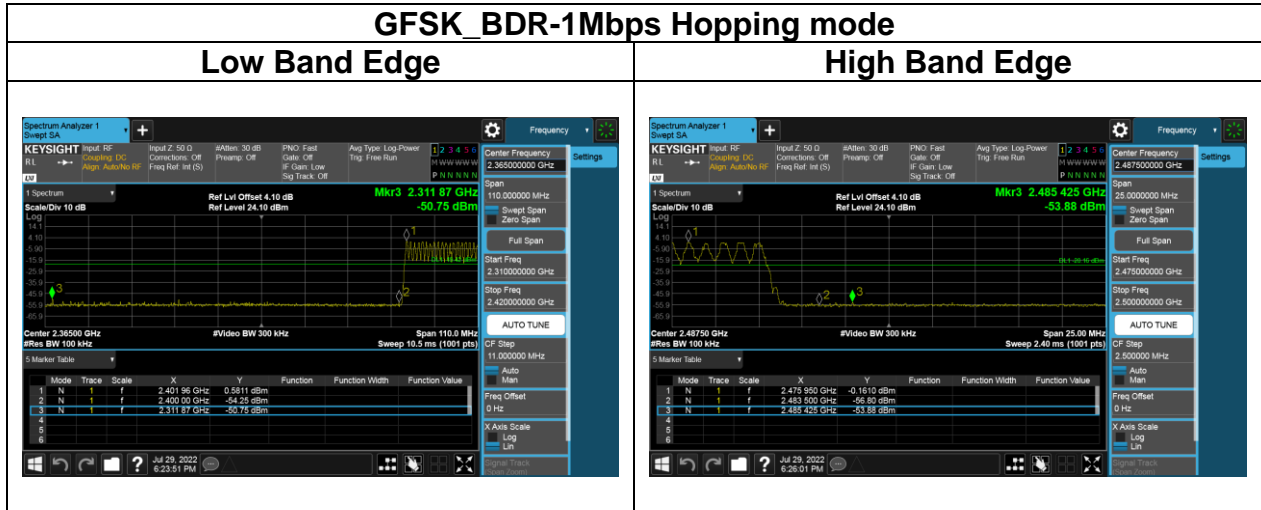

Report No.: TMWK2207002918KR

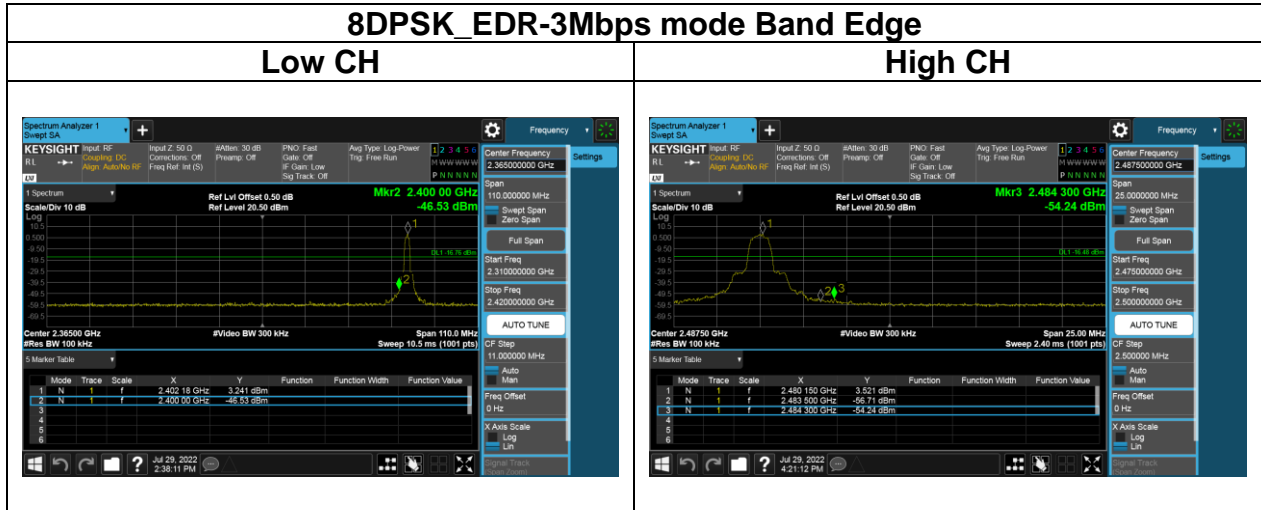

Report No.: TMWK2207002918KR

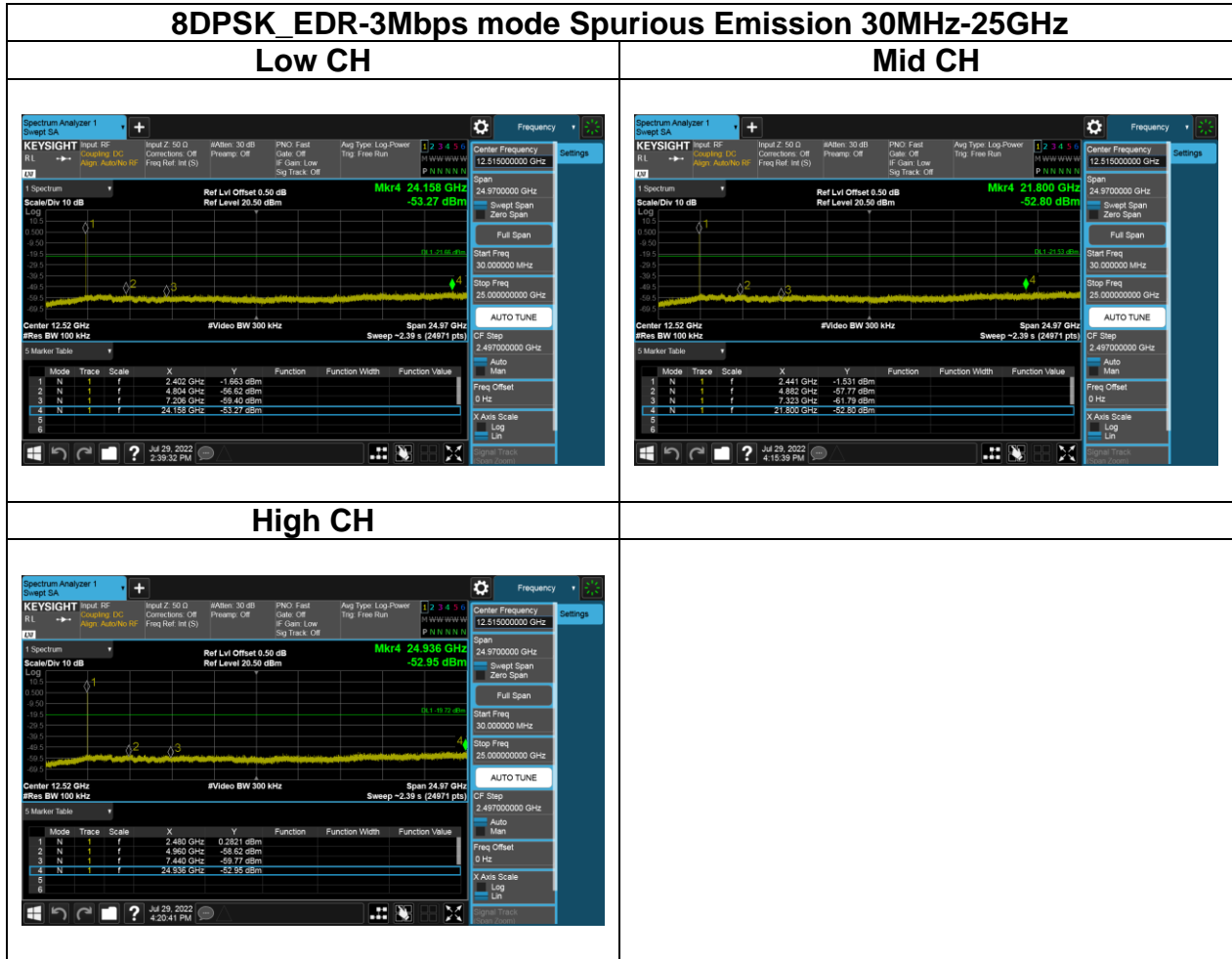

Report No.: TMWK2207002918KR

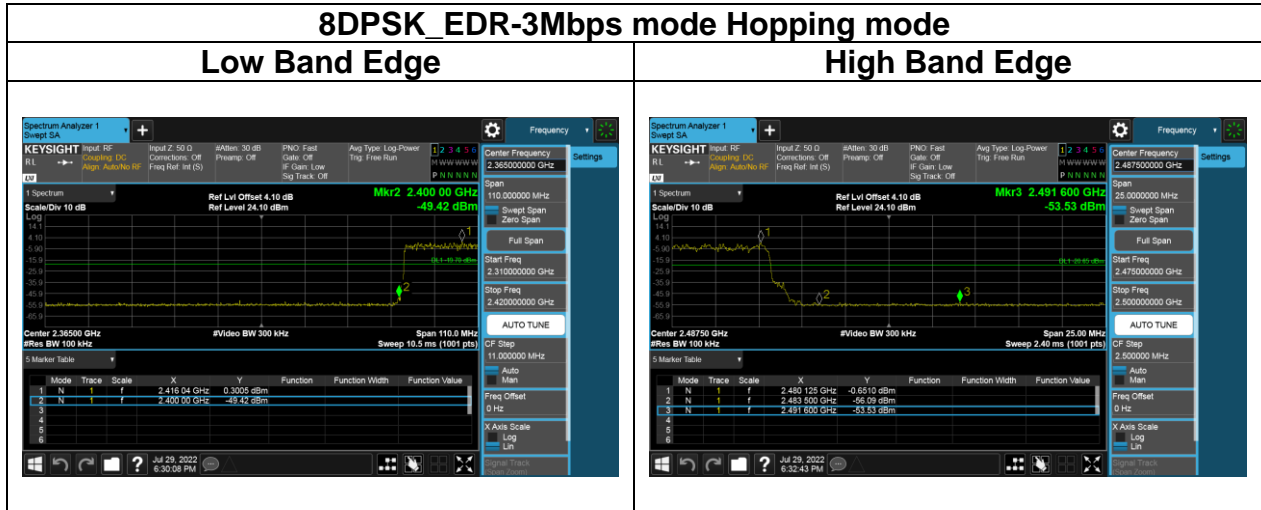

4.7 TIME OF OCCUPANCY (DWELL TIME)

4.7.1 Test Limit

According to §15.247(a)(1)(iii)

The average time of occupancy on any channel shall not be greater than 0.4 seconds within a period of 0.4 seconds multiplied by the number of hopping channels employed.

4.7.2 Test Procedure

1. EUT RF output port connected to the SA by RF cable.
2. Set center frequency of spectrum analyzer = operating frequency.
3. Set the spectrum analyzer as RBW, VBW=1MHz, Sweep = 1 ms

4.7.3 Test Setup

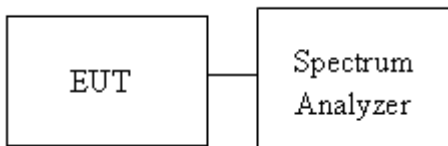

Report No.: TMWK2207002918KR

4.7.4 Test Result

Temperature: 26.6°C

Test date: July 29, 2022

Humidity: 53% RH

Tested by: David Li

For GFSK (1Mbps)

Channel	PACKET TYPE	Measurement Result (ms)	Limit (ms)
Mid	DH1	124.80	400ms
	DH3	262.40	400ms
	DH5	307.20	400ms

CH Mid DH1 time slot = 0.390 * (1600/2/79) * 31.6 = 124.80 (ms)
 DH3 time slot = 1.640 * (1600/4/79) * 31.6 = 262.40 (ms)
 DH5 time slot = 2.880 * (1600/6/79) * 31.6 = 307.20 (ms)

For 8-DPSK (3Mbps)

Channel	PACKET TYPE	Measurement Result (ms)	Limit (ms)
Mid	3DH1	123.20	400ms
	3DH3	262.40	400ms
	3DH5	310.40	400ms

CH Mid 3DH1 time slot = 0.385 * (1600/2/79) * 31.6 = 123.20 (ms)
 3DH3 time slot = 1.640 * (1600/4/79) * 31.6 = 262.40 (ms)
 3DH5 time slot = 2.910 * (1600/6/79) * 31.6 = 310.40 (ms)

Report No.: TMWK2207002918KR

For GFSK (1Mbps)



Report No.: TMWK2207002918KR

For 8-DPSK (3Mbps)



Report No.: TMWK2207002918KR

4.8 RADIATION BANDEDGE AND SPURIOUS EMISSION

4.8.1 Test Limit

FCC according to §15.247(d), §15.209 and §15.205,

In any 100 kHz bandwidth outside the authorized frequency band, all harmonic and spurious must be least 20 dB below the highest emission level with the authorized frequency band. Radiation emission which fall in the restricted bands must also follow the FCC section 15.209 as below limit in table.

Below 30 MHz

Frequency	Field Strength (microvolts/m)	Magnetic H-Field (microamperes/m)	Measurement Distance (metres)
9-490 kHz	2,400/F (F in kHz)	2,400/F (F in kHz)	300
490-1,705 kHz	24,000/F (F in kHz)	24,000/F (F in kHz)	30
1.705-30 MHz	30	N/A	30

Above 30 MHz

Frequency (MHz)	Field Strength microvolts/m at 3 metres (watts, e.i.r.p.)	
	Transmitters	Receivers
30-88	100 (3 nW)	100 (3 nW)
88-216	150 (6.8 nW)	150 (6.8 nW)
216-960	200 (12 nW)	200 (12 nW)
Above 960	500 (75 nW)	500 (75 nW)

Remark:

Although these tests were performed other than open area test site, adequate comparison measurements were confirmed against 30 m open are test site. Therefore sufficient tests were made to demonstrate that the alternative site produces results that correlate with the ones of tests made in an open field based on KDB 414788.

Report No.: TMWK2207002918KR

4.8.2 Test Procedure

1. The EUT is placed on a turntable, Above 1 GHz is 1.5m and below 1 GHz is 0.8m above ground plane. The EUT Configured un accordance with ANSI C63.10: 2013, and the EUT set in a continuous mode.

2. The turntable shall be rotated for 360 degrees to determine the position of maximum emission level. And EUT is set 3m away from the receiving antenna, which is scanned from 1m to 4m above the ground plane to find out the highest emissions. Measurement are made polarized in both the vertical and the horizontal positions with antenna.

3. Span shall wide enough to full capture the emission measured. The SA from 9kHz to 26.5GHz set to the low, Mid and High channels with the EUT transmit.

Note: No emission found between lowest internal used/generated frequency to 30MHz(9KHz~30MHz)

4. For harmonic, the worst case of output power was BDR-1Mbps. Therefore only BDR-1Mbps record in the report.

5. The SA setting following :

(1) Below 1G : RBW = 100kHz, VBW \geq 3 RBW, Sweep = Auto, Detector = Peak, Trace = Max hold.

(2) Above 1G :

(2.1) For Peak measurement : RBW = 1MHz, VBW \geq 3 RBW, Sweep = Auto, Detector = Peak, Trace = Max hold.

(2.2) For Average measurement : RBW = 1MHz, VBW

·If Duty Cycle \geq 98%, VBW=10Hz.

·If Duty Cycle < 98%, VBW \geq 1/T.

6. Data result

Actual FS=Spectrum Reading Level + Factor

Margin=Actual FS- Limit

Report No.: TMWK2207002918KR

4.8.3 Test Setup

9kHz ~ 30MHz

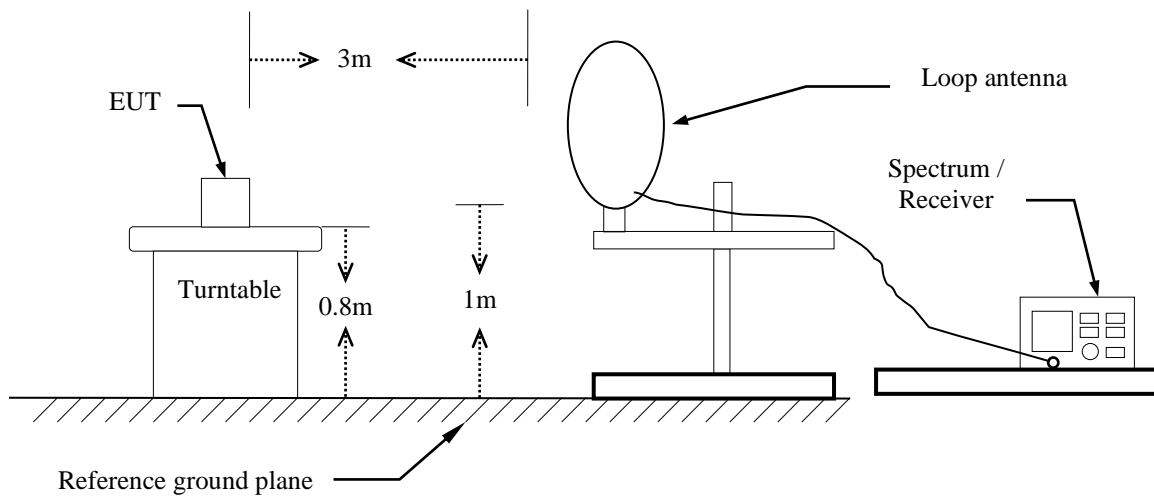

30MHz ~ 1GHz

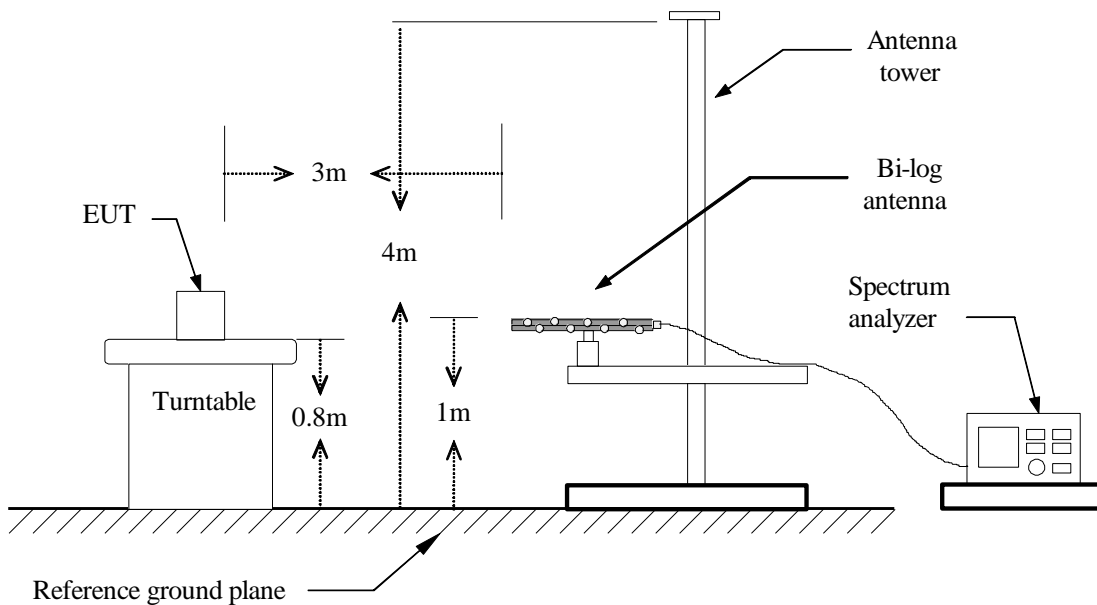

Above 1 GHz

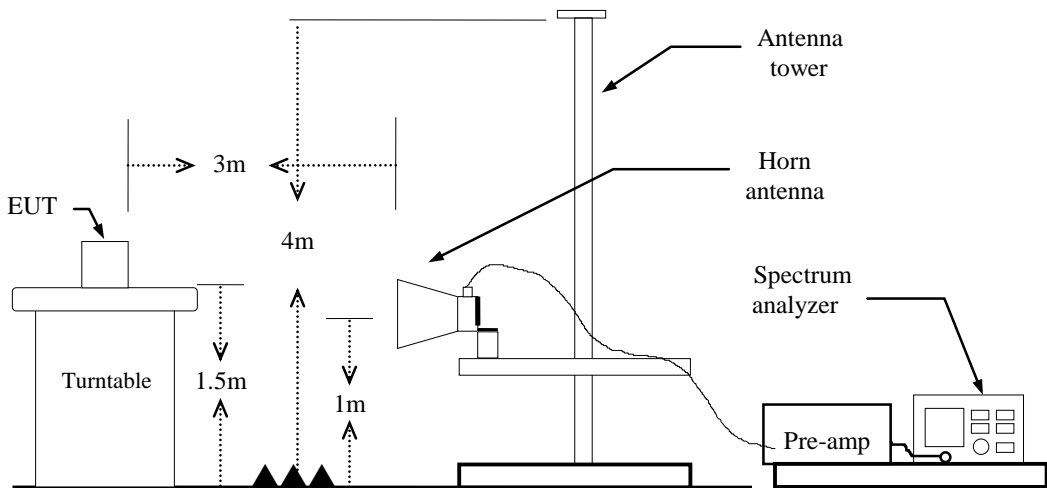

Report No.: TMWK2207002918KR

4.8.4 Test Result

Band Edge Test Data

Test Mode:	GFSK_BDR-1Mbps Low CH	Temp/Hum	24.4(°C)/ 64%RH
Test Item	Band Edge	Test Date	August 9, 2022
Polarize	Vertical	Test Engineer	Tony Chao
Detector	Peak / Average		

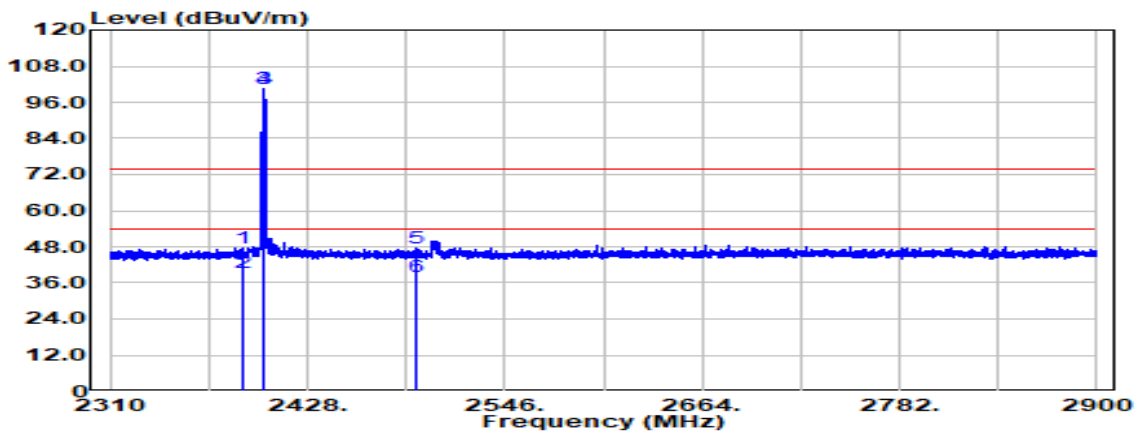

Freq. (MHz)	Detector Mode (PK/QP/AV)	Spectrum Reading Level (dB μ V)	Factor (dB)	Actual FS (dB μ V/m)	Limit @3m (dB μ V/m)	Margin (dB)
2389.886	Peak	39.67	7.75	47.42	74.00	-26.58
2389.886	Average	31.64	7.75	39.39	54.00	-14.61
2402.000	Peak	92.64	7.79	100.44	--	--
2402.000	Average	92.56	7.79	100.35	--	--
2492.546	Peak	39.34	8.30	47.64	74.00	-26.36
2492.546	Average	29.95	8.30	38.26	54.00	-15.74

Report No.: TMWK2207002918KR

Test Mode:	GFSK_BDR-1Mbps Low CH	Temp/Hum	24.4(°C)/ 64%RH
Test Item	Band Edge	Test Date	August 9, 2022
Polarize	Horizontal	Test Engineer	Tony Chao
Detector	Peak / Average		

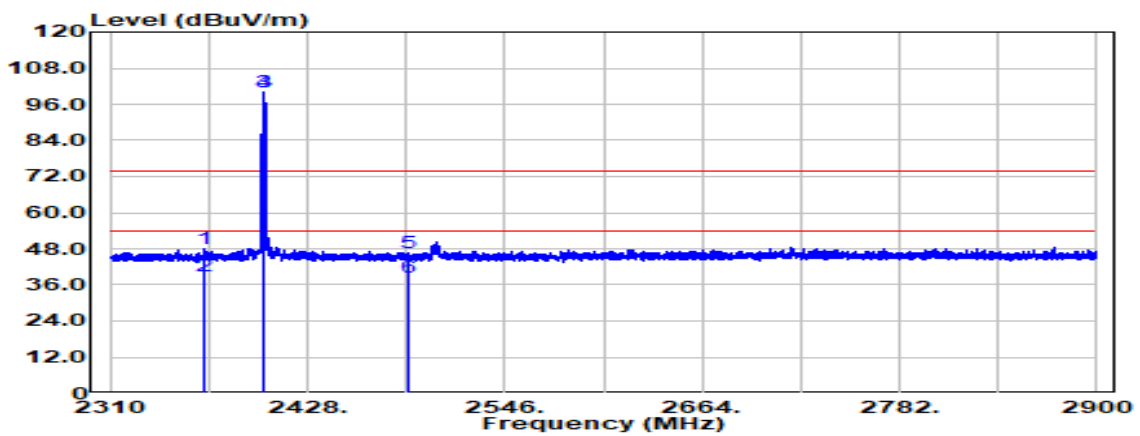

Freq. (MHz)	Detector Mode (PK/QP/AV)	Spectrum Reading Level (dBμV)	Factor (dB)	Actual FS (dBμV/m)	Limit @3m (dBμV/m)	Margin (dB)
2366.640	Peak	40.14	7.69	47.83	74.00	-26.17
2366.640	Average	31.20	7.69	38.89	54.00	-15.11
2402.000	Peak	92.34	7.79	100.13	--	--
2402.000	Average	92.20	7.79	99.99	--	--
2487.708	Peak	38.52	8.28	46.80	74.00	-27.20
2487.708	Average	30.11	8.28	38.39	54.00	-15.61

Report No.: TMWK2207002918KR

Test Mode:	GFSK_BDR-1Mbps High CH	Temp/Hum	24.4(°C)/ 64%RH
Test Item	Band Edge	Test Date	August 9, 2022
Polarize	Vertical	Test Engineer	Ray Li
Detector	Peak / Average		

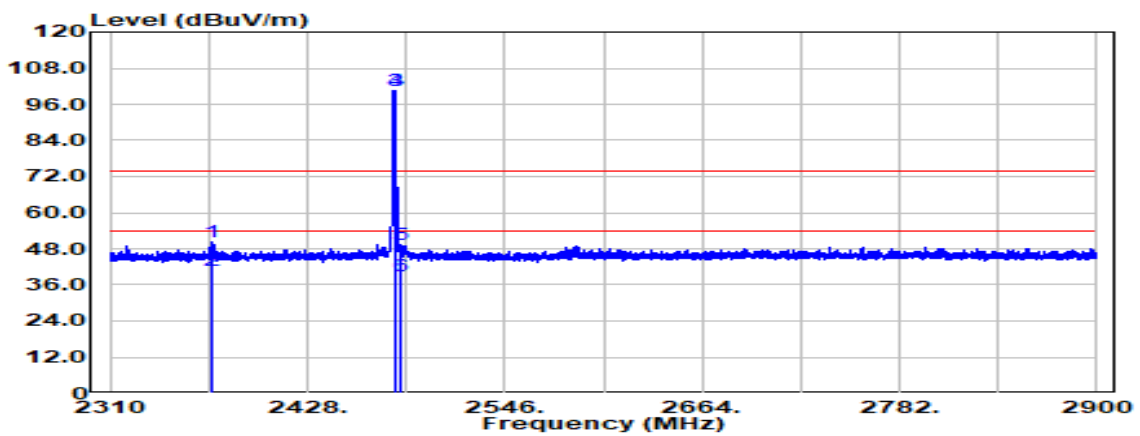

Freq. (MHz)	Detector Mode (PK/QP/AV)	Spectrum Reading Level (dBµV)	Factor (dB)	Actual FS (dBµV/m)	Limit @3m (dBµV/m)	Margin (dB)
2371.242	Peak	42.73	7.70	50.43	74.00	-23.57
2371.242	Average	33.16	7.70	40.86	54.00	-13.14
2480.000	Peak	92.41	8.24	100.65	--	--
2480.000	Average	92.26	8.24	100.50	--	--
2484.168	Peak	40.92	8.26	49.18	74.00	-24.82
2484.168	Average	30.58	8.26	38.85	54.00	-15.15

Report No.: TMWK2207002918KR

Test Mode:	GFSK_BDR-1Mbps High CH	Temp/Hum	24.4(°C)/ 64%RH
Test Item	Band Edge	Test Date	August 9, 2022
Polarize	Horizontal	Test Engineer	Ray Li
Detector	Peak / Average		

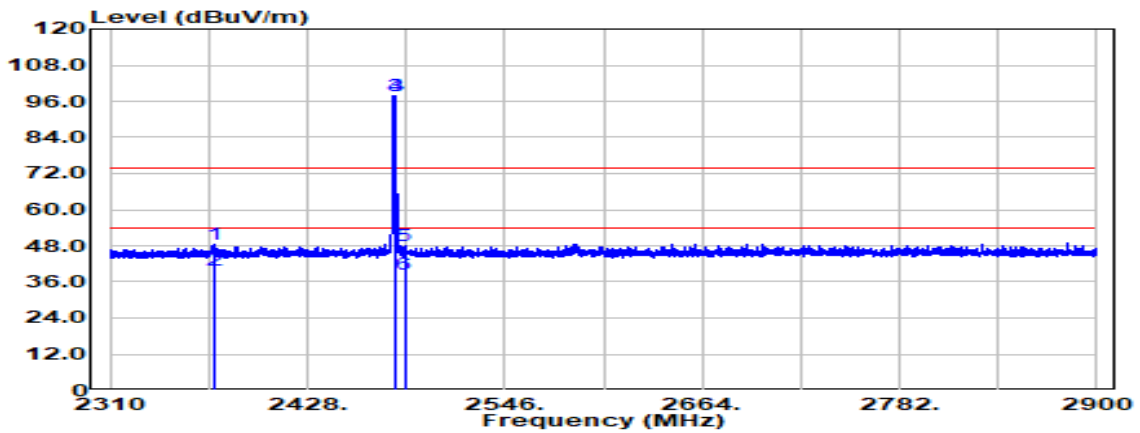

Freq. (MHz)	Detector Mode (PK/QP/AV)	Spectrum Reading Level (dBμV)	Factor (dB)	Actual FS (dBμV/m)	Limit @3m (dBμV/m)	Margin (dB)
2372.422	Peak	40.57	7.70	48.27	74.00	-25.73
2372.422	Average	32.17	7.70	39.87	54.00	-14.13
2480.000	Peak	89.67	8.24	97.91	--	--
2480.000	Average	89.49	8.24	97.73	--	--
2486.056	Peak	39.92	8.27	48.20	74.00	-25.80
2486.056	Average	30.21	8.27	38.49	54.00	-15.51

Report No.: TMWK2207002918KR

Test Mode:	GFSK_BDR-1Mbps Hopping	Temp/Hum	24.5(°C)/ 63%RH
Test Item	Band Edge	Test Date	August 12, 2022
Polarize	Vertical	Test Engineer	Tony Chao
Detector	Peak / Average		

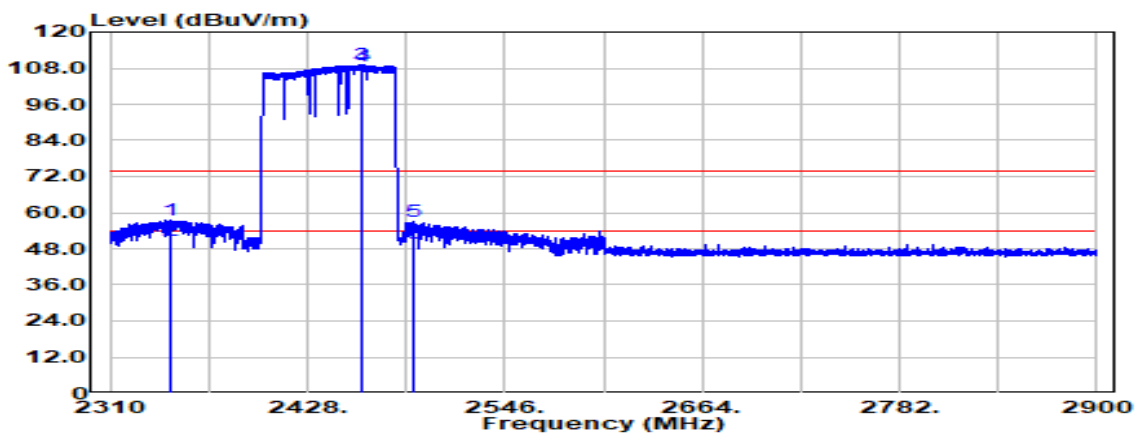

Freq. (MHz)	Detector Mode (PK/QP/AV)	Spectrum Reading Level (dBμV)	Factor (dB)	Actual FS (dBμV/m)	Limit @3m (dBμV/m)	Margin (dB)
2346.344	Peak	49.72	7.63	57.36	74.00	-16.64
2346.344	Average	42.94	7.63	50.57	54.00	-3.43
2460.096	Peak	100.80	8.15	108.94	--	--
2460.096	Average	100.49	8.15	108.64	--	--
2490.776	Peak	48.76	8.30	57.05	74.00	-16.95
2490.776	Average	41.31	8.30	49.61	54.00	-4.39

Report No.: TMWK2207002918KR

Test Mode:	GFSK_BDR-1Mbps Hopping	Temp/Hum	24.5(°C)/ 63%RH
Test Item	Band Edge	Test Date	August 12, 2022
Polarize	Horizontal	Test Engineer	Tony Chao
Detector	Peak / Average		



Freq. (MHz)	Detector Mode (PK/QP/AV)	Spectrum Reading Level (dB μ V)	Factor (dB)	Actual FS (dB μ V/m)	Limit @3m (dB μ V/m)	Margin (dB)
2335.488	Peak	44.34	7.62	51.96	74.00	-22.04
2335.488	Average	35.84	7.62	43.46	54.00	-10.54
2455.140	Peak	93.36	8.12	101.48	--	--
2455.140	Average	93.08	8.12	101.20	--	--
2491.012	Peak	41.46	8.30	49.76	74.00	-24.24
2491.012	Average	33.03	8.30	41.32	54.00	-12.68

Report No.: TMWK2207002918KR

Test Mode:	8DPSK_EDR-3Mbps Low CH	Temp/Hum	24.4(°C)/ 64%RH
Test Item	Band Edge	Test Date	August 9, 2022
Polarize	Vertical	Test Engineer	Ray Li
Detector	Peak / Average		

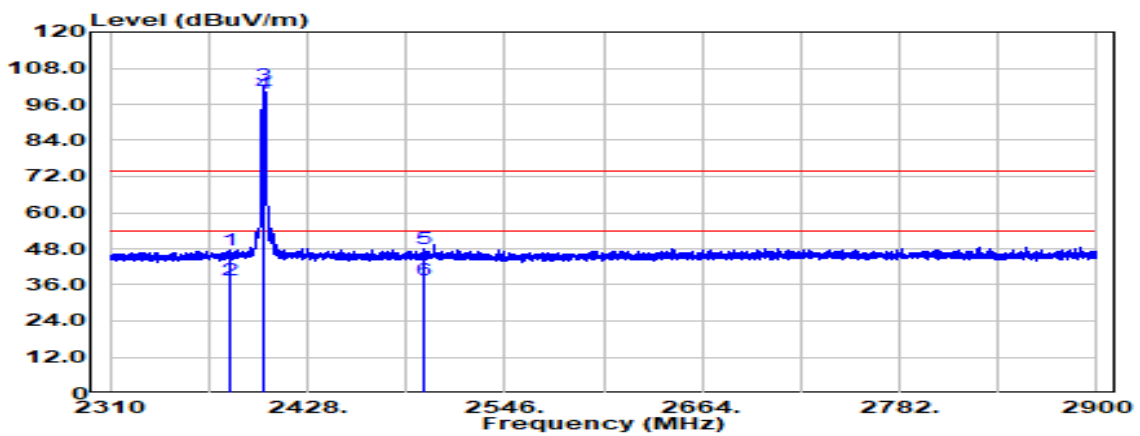

Freq. (MHz)	Detector Mode (PK/QP/AV)	Spectrum Reading Level (dBμV)	Factor (dB)	Actual FS (dBμV/m)	Limit @3m (dBμV/m)	Margin (dB)
2382.216	Peak	39.92	7.73	47.65	74.00	-26.35
2382.216	Average	30.06	7.73	37.79	54.00	-16.21
2402.000	Peak	94.75	7.79	102.55	--	--
2402.000	Average	91.81	7.79	99.61	--	--
2497.620	Peak	39.56	8.33	47.89	74.00	-26.11
2497.620	Average	29.25	8.33	37.58	54.00	-16.42

Report No.: TMWK2207002918KR

Test Mode:	8DPSK_EDR-3Mbps Low CH	Temp/Hum	24.4(°C)/ 64%RH
Test Item	Band Edge	Test Date	August 9, 2022
Polarize	Horizontal	Test Engineer	Ray Li
Detector	Peak / Average		

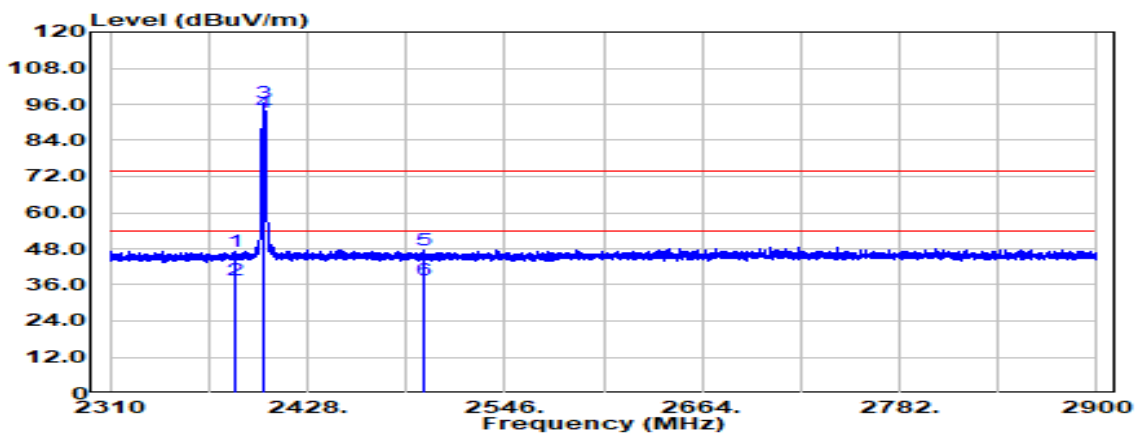

Freq. (MHz)	Detector Mode (PK/QP/AV)	Spectrum Reading Level (dBµV)	Factor (dB)	Actual FS (dBµV/m)	Limit @3m (dBµV/m)	Margin (dB)
2385.284	Peak	39.43	7.74	47.17	74.00	-26.83
2385.284	Average	29.73	7.74	37.47	54.00	-16.53
2402.000	Peak	88.62	7.79	96.41	--	--
2402.000	Average	85.69	7.79	93.48	--	--
2497.266	Peak	39.39	8.33	47.71	74.00	-26.29
2497.266	Average	29.27	8.33	37.60	54.00	-16.40

Report No.: TMWK2207002918KR

Test Mode:	8DPSK_EDR-3Mbps High CH	Temp/Hum	24.4(°C)/ 64%RH
Test Item	Band Edge	Test Date	August 9, 2022
Polarize	Vertical	Test Engineer	Ray Li
Detector	Peak / Average		

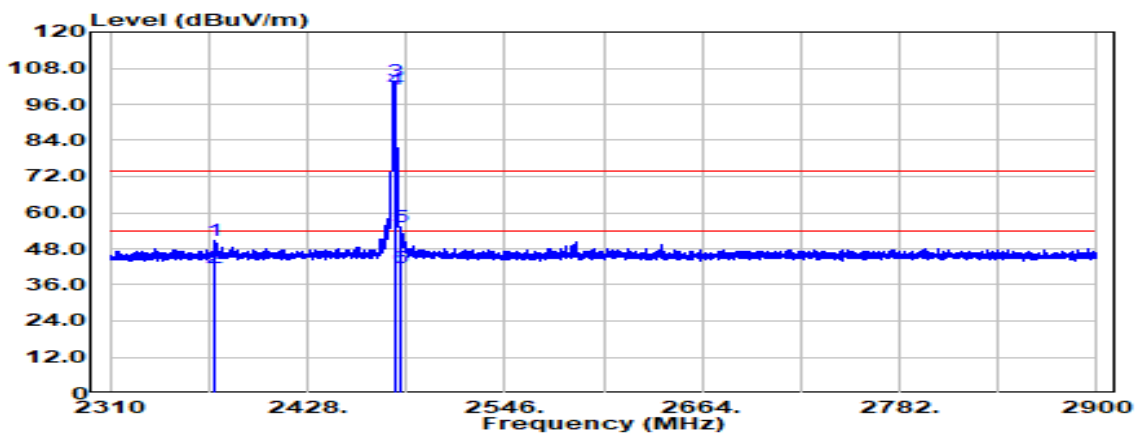

Freq. (MHz)	Detector Mode (PK/QP/AV)	Spectrum Reading Level (dBμV)	Factor (dB)	Actual FS (dBμV/m)	Limit @3m (dBμV/m)	Margin (dB)
2372.422	Peak	42.83	7.70	50.54	74.00	-23.46
2372.422	Average	34.00	7.70	41.70	54.00	-12.30
2480.000	Peak	95.37	8.24	103.62	--	--
2480.000	Average	92.60	8.24	100.84	--	--
2484.286	Peak	46.77	8.26	55.03	74.00	-18.97
2484.286	Average	33.49	8.26	41.75	54.00	-12.25

Report No.: TMWK2207002918KR

Test Mode:	8DPSK_EDR-3Mbps High CH	Temp/Hum	24.4(°C)/ 64%RH
Test Item	Band Edge	Test Date	August 9, 2022
Polarize	Horizontal	Test Engineer	Ray Li
Detector	Peak / Average		

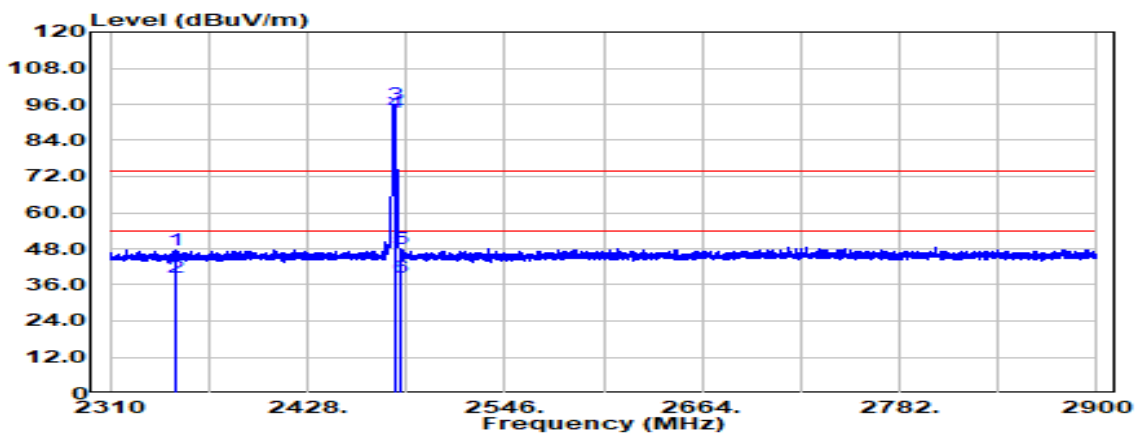

Freq. (MHz)	Detector Mode (PK/QP/AV)	Spectrum Reading Level (dBμV)	Factor (dB)	Actual FS (dBμV/m)	Limit @3m (dBμV/m)	Margin (dB)
2349.294	Peak	39.93	7.64	47.57	74.00	-26.43
2349.294	Average	30.98	7.64	38.62	54.00	-15.38
2480.000	Peak	87.69	8.24	95.93	--	--
2480.000	Average	84.93	8.24	93.17	--	--
2483.500	Peak	39.89	8.26	48.15	74.00	-25.85
2483.500	Average	30.07	8.26	38.33	54.00	-15.67

Report No.: TMWK2207002918KR

Test Mode:	8DPSK_EDR-3Mbps Hopping	Temp/Hum	24.5(°C)/ 63%RH
Test Item	Band Edge	Test Date	August 12, 2022
Polarize	Vertical	Test Engineer	Tony Chao
Detector	Peak / Average		

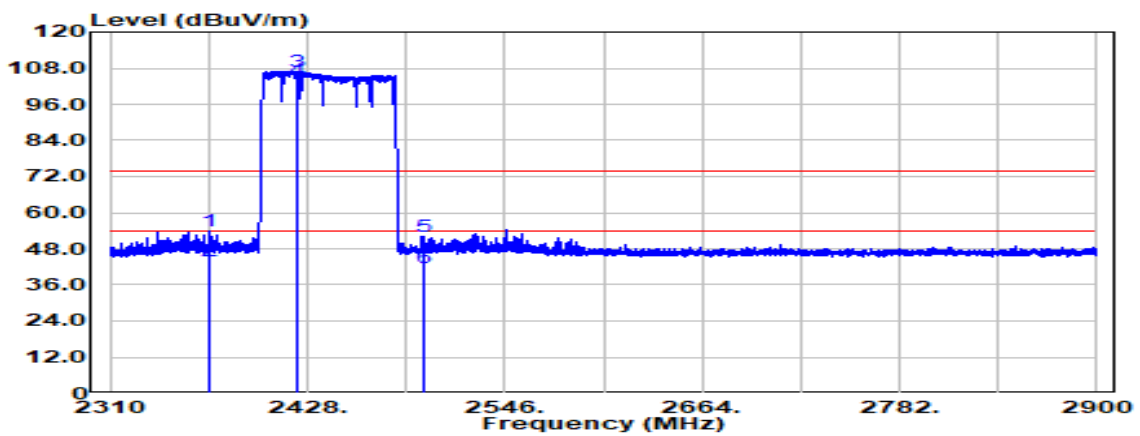

Freq. (MHz)	Detector Mode (PK/QP/AV)	Spectrum Reading Level (dBµV)	Factor (dB)	Actual FS (dBµV/m)	Limit @3m (dBµV/m)	Margin (dB)
2369.590	Peak	46.22	7.69	53.92	74.00	-20.08
2369.590	Average	36.29	7.69	43.99	54.00	-10.01
2421.982	Peak	99.02	7.92	106.94	--	--
2421.982	Average	96.45	7.92	104.38	--	--
2496.912	Peak	43.79	8.33	52.11	74.00	-21.89
2496.912	Average	33.39	8.33	41.71	54.00	-12.29

Report No.: TMWK2207002918KR

Test Mode:	8DPSK_EDR-3Mbps Hopping	Temp/Hum	24.5(°C)/ 63%RH
Test Item	Band Edge	Test Date	August 12, 2022
Polarize	Horizontal	Test Engineer	Tony Chao
Detector	Peak / Average		



Freq. (MHz)	Detector Mode (PK/QP/AV)	Spectrum Reading Level (dBμV)	Factor (dB)	Actual FS (dBμV/m)	Limit @3m (dBμV/m)	Margin (dB)
2366.640	Peak	40.25	7.69	47.93	74.00	-26.07
2366.640	Average	29.84	7.69	37.53	54.00	-16.47
2430.006	Peak	91.30	7.97	99.27	--	--
2430.006	Average	88.52	7.97	96.49	--	--
2486.410	Peak	40.40	8.27	48.67	74.00	-25.33
2486.410	Average	29.45	8.27	37.72	54.00	-16.28

Report No.: TMWK2207002918KR

Below 1G Test Data

Test Mode:	GFSK_EDR-3Mbps High CH	Temp/Hum	24.1(°C)/ 62%RH
Test Item	30MHz-1GHz	Test Date	August 12, 2022
Polarize	Vertical	Test Engineer	Ray Li
Detector	Peak		

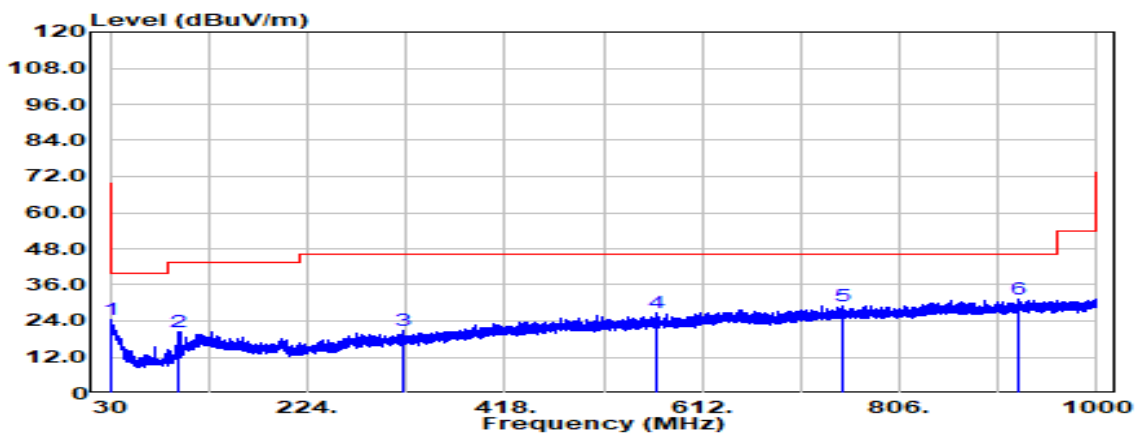

Freq. (MHz)	Detector Mode (PK/QP/AV)	Spectrum Reading Level (dBµV)	Factor (dB)	Actual FS (dBµV/m)	Limit @3m (dBµV/m)	Margin (dB)
32.061	Peak	28.28	-3.78	24.50	40.00	-15.50
98.264	Peak	33.99	-13.58	20.42	43.50	-23.08
317.605	Peak	29.15	-8.46	20.69	46.00	-25.31
567.865	Peak	29.18	-2.45	26.73	46.00	-19.27
749.619	Peak	28.52	0.39	28.91	46.00	-17.09
922.158	Peak	28.37	2.98	31.36	46.00	-14.64

Report No.: TMWK2207002918KR

Test Mode:	GFSK_EDR-3Mbps High CH	Temp/Hum	24.1(°C)/ 62%RH
Test Item	30MHz-1GHz	Test Date	August 12, 2022
Polarize	Horizontal	Test Engineer	Ray Li
Detector	Peak		

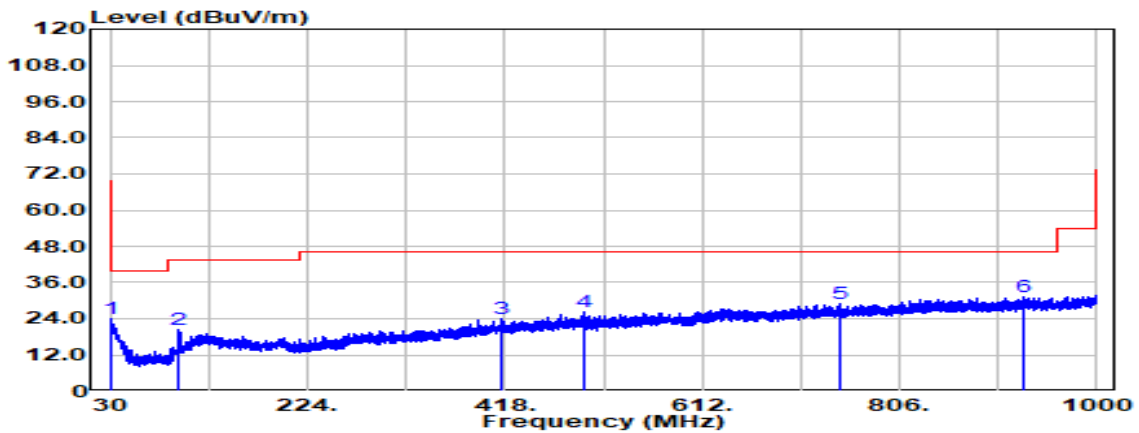

Freq. (MHz)	Detector Mode (PK/QP/AV)	Spectrum Reading Level (dBμV)	Factor (dB)	Actual FS (dBμV/m)	Limit @3m (dBμV/m)	Margin (dB)
30.728	Peak	27.93	-3.73	24.20	40.00	-15.80
98.264	Peak	33.74	-13.58	20.17	43.50	-23.33
413.514	Peak	29.57	-5.57	24.01	46.00	-22.00
497.055	Peak	29.90	-3.86	26.04	46.00	-19.96
748.528	Peak	28.44	0.39	28.83	46.00	-17.17
928.948	Peak	27.99	3.15	31.14	46.00	-14.86

Report No.: TMWK2207002918KR

Above 1G Test Data

Test Mode:	GFSK_BDR-1Mbps Low CH	Temp/Hum	24.4(°C)/ 64%RH
Test Item	Harmonic	Test Date	August 9, 2022
Polarize	Vertical	Test Engineer	Ray Li
Detector	Peak / Average		

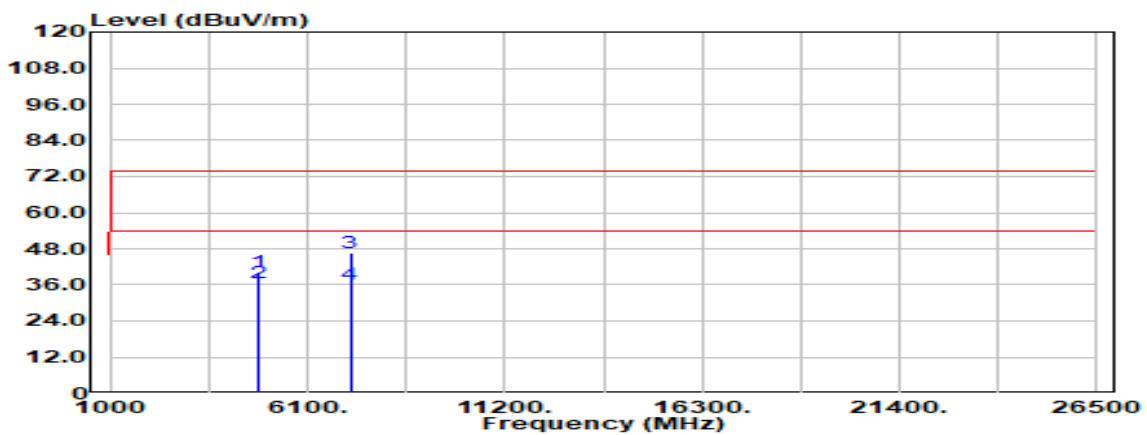

Freq. (MHz)	Detector Mode (PK/QP/AV)	Spectrum Reading Level (dBµV)	Factor (dB)	Actual FS (dBµV/m)	Limit @3m (dBµV/m)	Margin (dB)
4804.000	Peak	34.35	5.87	40.21	74.00	-33.79
4804.000	Average	30.92	5.87	36.79	54.00	-17.21
7206.000	Peak	33.29	13.25	46.54	74.00	-27.46
7206.000	Average	23.06	13.25	36.31	54.00	-17.69
N/A						

Remark:

1. Measuring frequencies from 1 GHz to the 10th harmonic of highest fundamental frequency.

Report No.: TMWK2207002918KR

Test Mode:	GFSK_BDR-1Mbps Low CH	Temp/Hum	24.4(°C)/ 64%RH
Test Item	Harmonic	Test Date	August 9, 2022
Polarize	Horizontal	Test Engineer	Ray Li
Detector	Peak / Average		

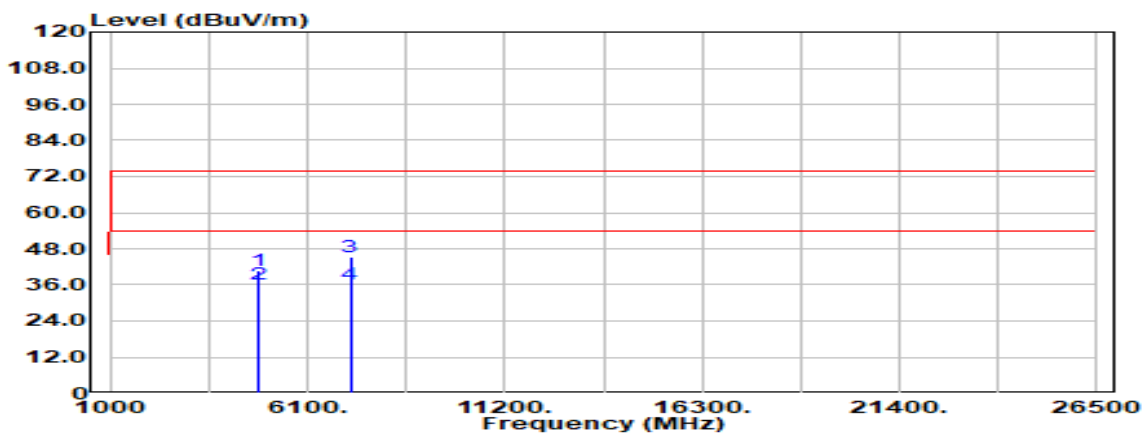

Freq. (MHz)	Detector Mode (PK/QP/AV)	Spectrum Reading Level (dBμV)	Factor (dB)	Actual FS (dBμV/m)	Limit @3m (dBμV/m)	Margin (dB)
4804.000	Peak	34.91	5.87	40.78	74.00	-33.22
4804.000	Average	30.27	5.87	36.14	54.00	-17.86
7206.000	Peak	32.19	13.25	45.44	74.00	-28.56
7206.000	Average	23.02	13.25	36.27	54.00	-17.73
N/A						

Remark:

1. Measuring frequencies from 1 GHz to the 10th harmonic of highest fundamental frequency.

Report No.: TMWK2207002918KR

Test Mode:	GFSK_BDR-1Mbps Mid CH	Temp/Hum	24.4(°C)/ 64%RH
Test Item	Harmonic	Test Date	August 10, 2022
Polarize	Vertical	Test Engineer	Ray Li
Detector	Peak / Average		

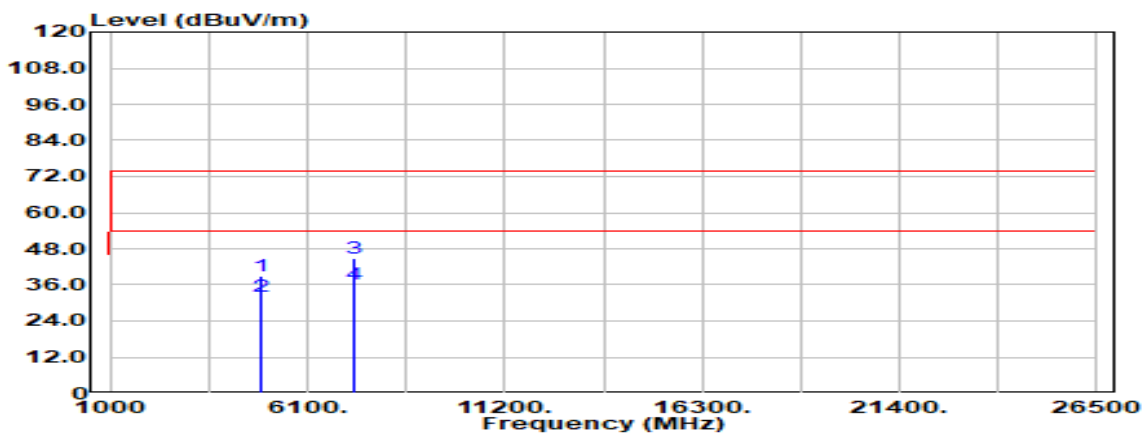

Freq. (MHz)	Detector Mode (PK/QP/AV)	Spectrum Reading Level (dBμV)	Factor (dB)	Actual FS (dBμV/m)	Limit @3m (dBμV/m)	Margin (dB)
4882.000	Peak	32.65	6.14	38.79	74.00	-35.21
4882.000	Average	25.84	6.14	31.98	54.00	-22.02
7323.000	Peak	31.37	13.36	44.72	74.00	-29.28
7323.000	Average	22.69	13.36	36.05	54.00	-17.95
N/A						

Remark:

1. Measuring frequencies from 1 GHz to the 10th harmonic of highest fundamental frequency.

Report No.: TMWK2207002918KR

Test Mode:	GFSK_BDR-1Mbps Mid CH	Temp/Hum	24.4(°C)/ 64%RH
Test Item	Harmonic	Test Date	August 10, 2022
Polarize	Horizontal	Test Engineer	Ray Li
Detector	Peak / Average		

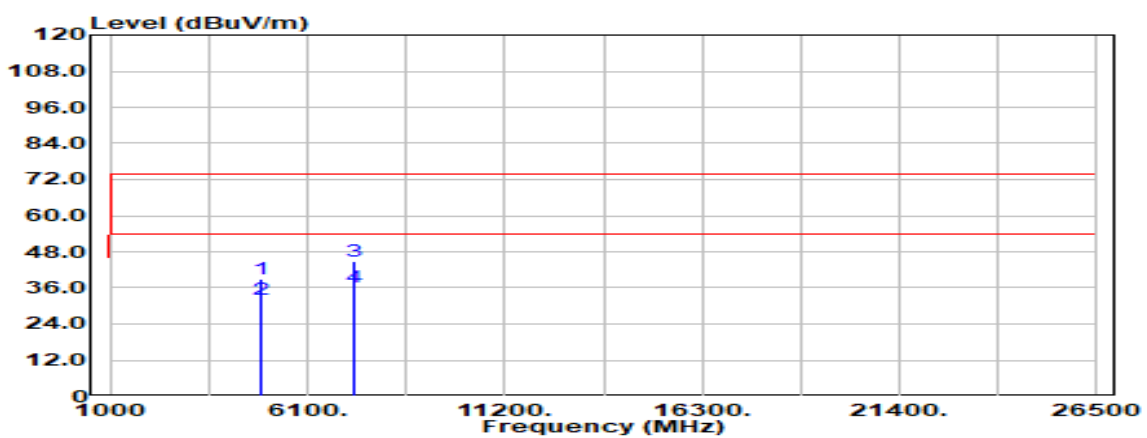

Freq. (MHz)	Detector Mode (PK/QP/AV)	Spectrum Reading Level (dBμV)	Factor (dB)	Actual FS (dBμV/m)	Limit @3m (dBμV/m)	Margin (dB)
4882.000	Peak	32.64	6.14	38.78	74.00	-35.22
4882.000	Average	26.08	6.14	32.22	54.00	-21.78
7323.000	Peak	31.42	13.36	44.78	74.00	-29.22
7323.000	Average	22.73	13.36	36.08	54.00	-17.92
N/A						

Remark:

1. Measuring frequencies from 1 GHz to the 10th harmonic of highest fundamental frequency.

Report No.: TMWK2207002918KR

Test Mode:	GFSK_BDR-1Mbps High CH	Temp/Hum	24.4(°C)/ 64%RH
Test Item	Harmonic	Test Date	August 10, 2022
Polarize	Vertical	Test Engineer	Ray Li
Detector	Peak / Average		

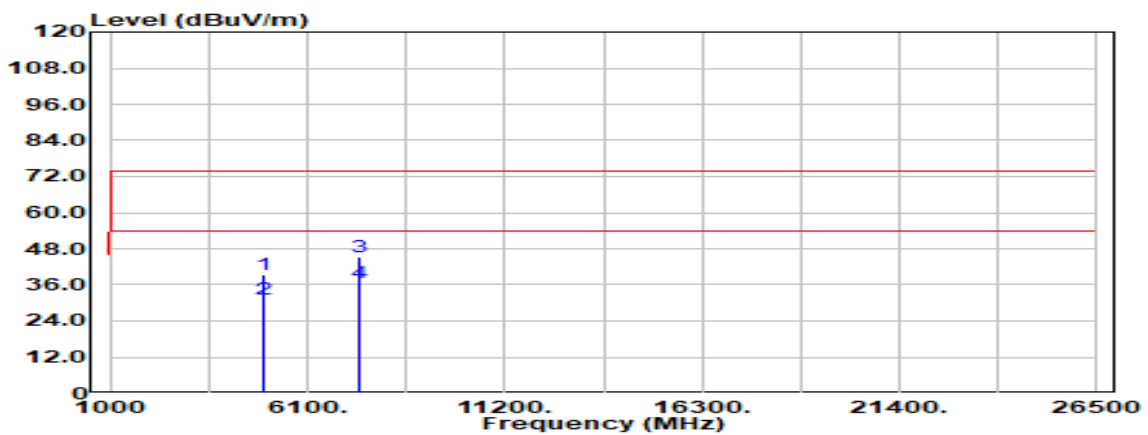

Freq. (MHz)	Detector Mode (PK/QP/AV)	Spectrum Reading Level (dBμV)	Factor (dB)	Actual FS (dBμV/m)	Limit @3m (dBμV/m)	Margin (dB)
4960.000	Peak	32.59	6.91	39.50	74.00	-34.50
4960.000	Average	24.29	6.91	31.20	54.00	-22.80
7440.000	Peak	31.94	13.22	45.16	74.00	-28.84
7440.000	Average	23.58	13.22	36.80	54.00	-17.20
N/A						

Remark:

- Measuring frequencies from 1 GHz to the 10th harmonic of highest fundamental frequency.

Report No.: TMWK2207002918KR

Test Mode:	GFSK_BDR-1Mbps High CH	Temp/Hum	24.4(°C)/ 64%RH
Test Item	Harmonic	Test Date	August 10, 2022
Polarize	Horizontal	Test Engineer	Ray Li
Detector	Peak / Average		

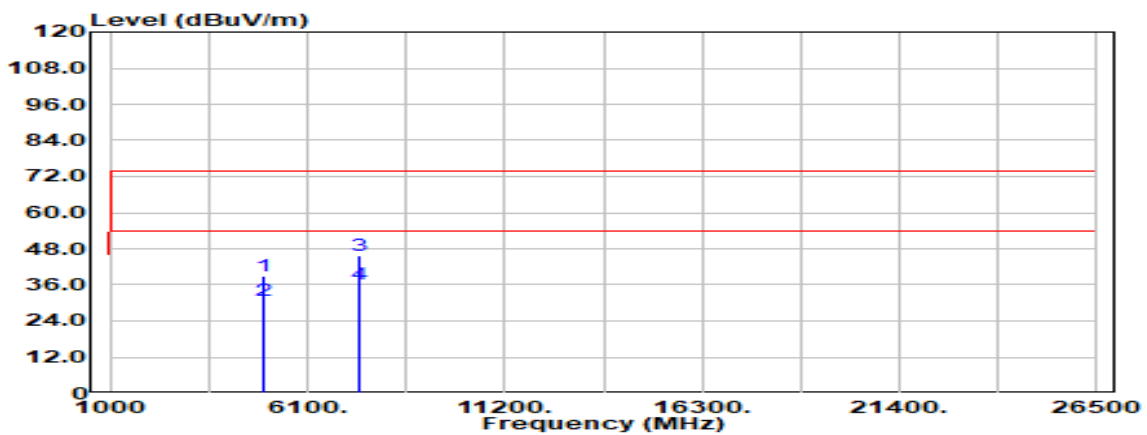

Freq. (MHz)	Detector Mode (PK/QP/AV)	Spectrum Reading Level (dB μ V)	Factor (dB)	Actual FS (dB μ V/m)	Limit @3m (dB μ V/m)	Margin (dB)
4960.000	Peak	32.19	6.91	39.10	74.00	-34.90
4960.000	Average	23.68	6.91	30.59	54.00	-23.41
7440.000	Peak	32.63	13.22	45.85	74.00	-28.15
7440.000	Average	23.15	13.22	36.37	54.00	-17.63
N/A						

Remark:

- Measuring frequencies from 1 GHz to the 10th harmonic of highest fundamental frequency.

Report No.: TMWK2207002918KR

Test Mode:	8DPSK_EDR-3Mbps Low CH	Temp/Hum	24.4(°C)/ 64%RH
Test Item	Harmonic	Test Date	August 10, 2022
Polarize	Vertical	Test Engineer	Ray Li
Detector	Peak / Average		

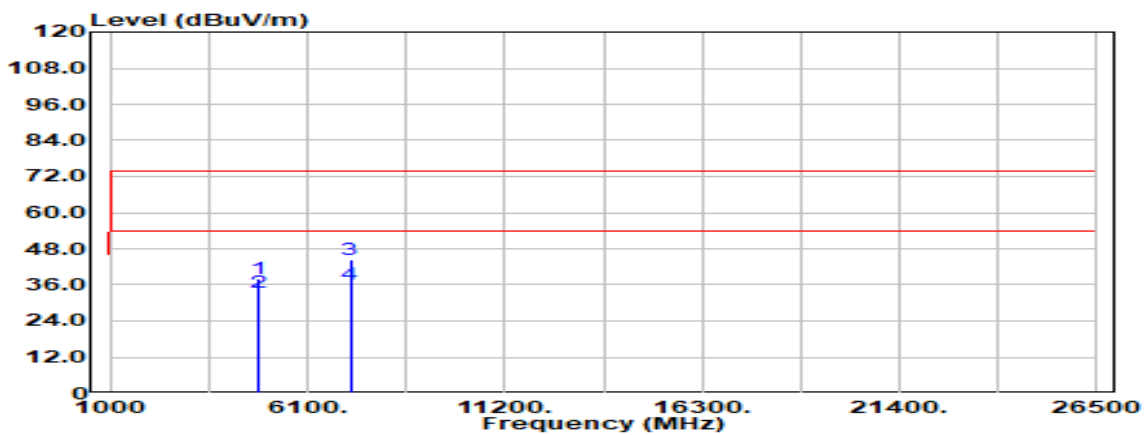

Freq. (MHz)	Detector Mode (PK/QP/AV)	Spectrum Reading Level (dBμV)	Factor (dB)	Actual FS (dBμV/m)	Limit @3m (dBμV/m)	Margin (dB)
4804.000	Peak	32.32	5.87	38.19	74.00	-35.81
4804.000	Average	27.79	5.87	33.66	54.00	-20.34
7206.000	Peak	31.34	13.25	44.60	74.00	-29.40
7206.000	Average	22.96	13.25	36.21	54.00	-17.79
N/A						

Remark:

1. Measuring frequencies from 1 GHz to the 10th harmonic of highest fundamental frequency.

Report No.: TMWK2207002918KR

Test Mode:	8DPSK_EDR-3Mbps Low CH	Temp/Hum	24.4(°C)/ 64%RH
Test Item	Harmonic	Test Date	August 10, 2022
Polarize	Horizontal	Test Engineer	Ray Li
Detector	Peak / Average		

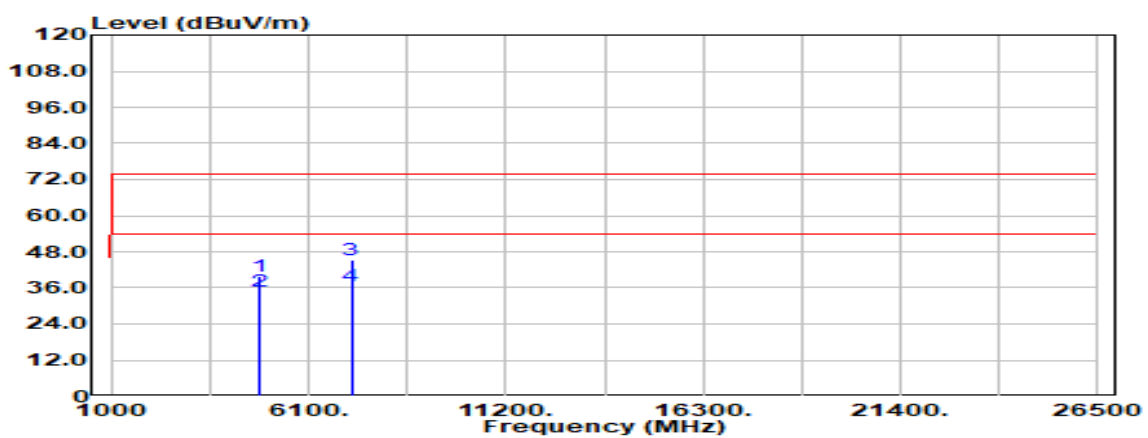

Freq. (MHz)	Detector Mode (PK/QP/AV)	Spectrum Reading Level (dBμV)	Factor (dB)	Actual FS (dBμV/m)	Limit @3m (dBμV/m)	Margin (dB)
4804.000	Peak	34.10	5.87	39.96	74.00	-34.04
4804.000	Average	28.86	5.87	34.72	54.00	-19.28
7206.000	Peak	31.98	13.25	45.23	74.00	-28.77
7206.000	Average	23.21	13.25	36.46	54.00	-17.54
N/A						

Remark:

1. Measuring frequencies from 1 GHz to the 10th harmonic of highest fundamental frequency.

Report No.: TMWK2207002918KR

Test Mode:	8DPSK_EDR-3Mbps Mid CH	Temp/Hum	24.4(°C)/ 64%RH
Test Item	Harmonic	Test Date	August 10, 2022
Polarize	Vertical	Test Engineer	Ray Li
Detector	Peak / Average		

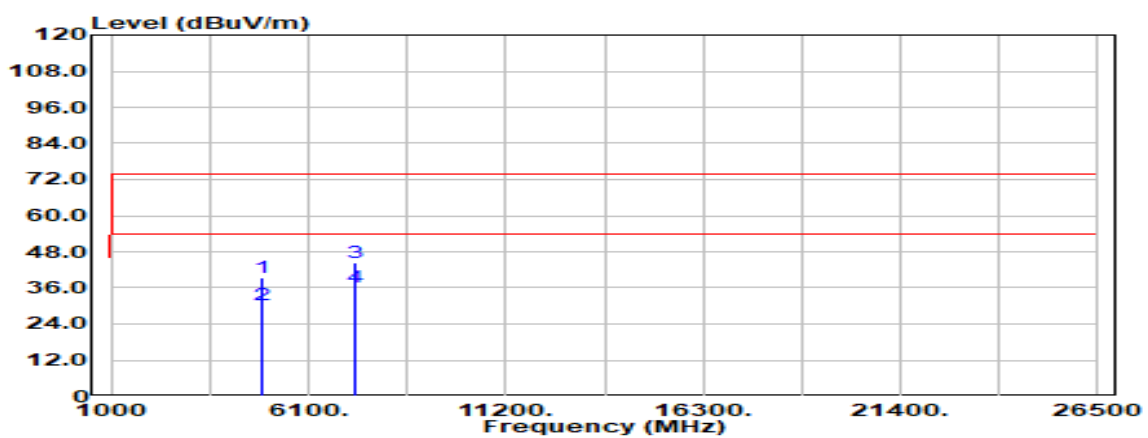

Freq. (MHz)	Detector Mode (PK/QP/AV)	Spectrum Reading Level (dB μ V)	Factor (dB)	Actual FS (dB μ V/m)	Limit @3m (dB μ V/m)	Margin (dB)
4882.000	Peak	33.27	6.14	39.41	74.00	-34.59
4882.000	Average	24.16	6.14	30.30	54.00	-23.70
7323.000	Peak	31.24	13.36	44.59	74.00	-29.41
7323.000	Average	22.73	13.36	36.09	54.00	-17.91
N/A						

Remark:

1. Measuring frequencies from 1 GHz to the 10th harmonic of highest fundamental frequency.

Report No.: TMWK2207002918KR

Test Mode:	8DPSK_EDR-3Mbps Mid CH	Temp/Hum	24.4(°C)/ 64%RH
Test Item	Harmonic	Test Date	August 10, 2022
Polarize	Horizontal	Test Engineer	Ray Li
Detector	Peak / Average		

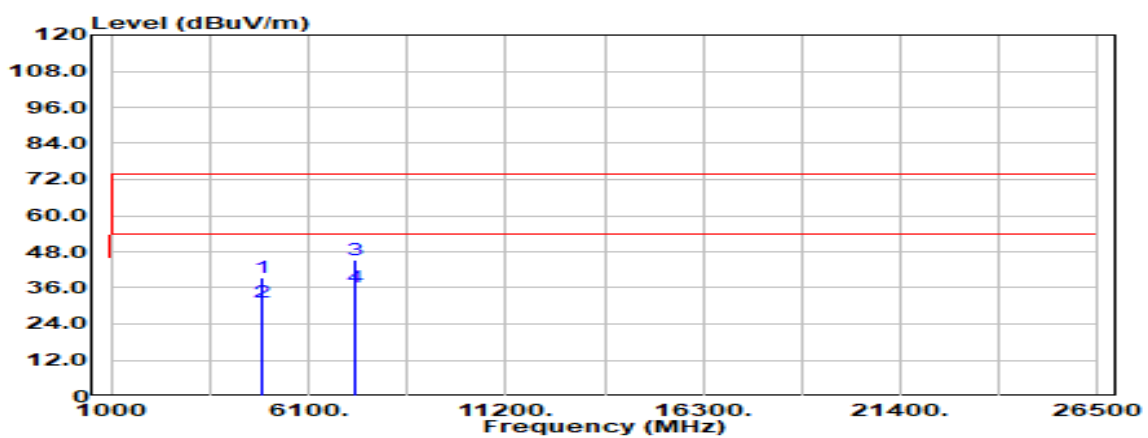

Freq. (MHz)	Detector Mode (PK/QP/AV)	Spectrum Reading Level (dB μ V)	Factor (dB)	Actual FS (dB μ V/m)	Limit @3m (dB μ V/m)	Margin (dB)
4882.000	Peak	33.28	6.14	39.42	74.00	-34.58
4882.000	Average	25.24	6.14	31.38	54.00	-22.62
7323.000	Peak	31.92	13.36	45.28	74.00	-28.72
7323.000	Average	22.82	13.36	36.17	54.00	-17.83
N/A						

Remark:

1. Measuring frequencies from 1 GHz to the 10th harmonic of highest fundamental frequency.

Report No.: TMWK2207002918KR

Test Mode:	8DPSK_EDR-3Mbps High CH	Temp/Hum	24.4(°C)/ 64%RH
Test Item	Harmonic	Test Date	August 10, 2022
Polarize	Vertical	Test Engineer	Ray Li
Detector	Peak / Average		

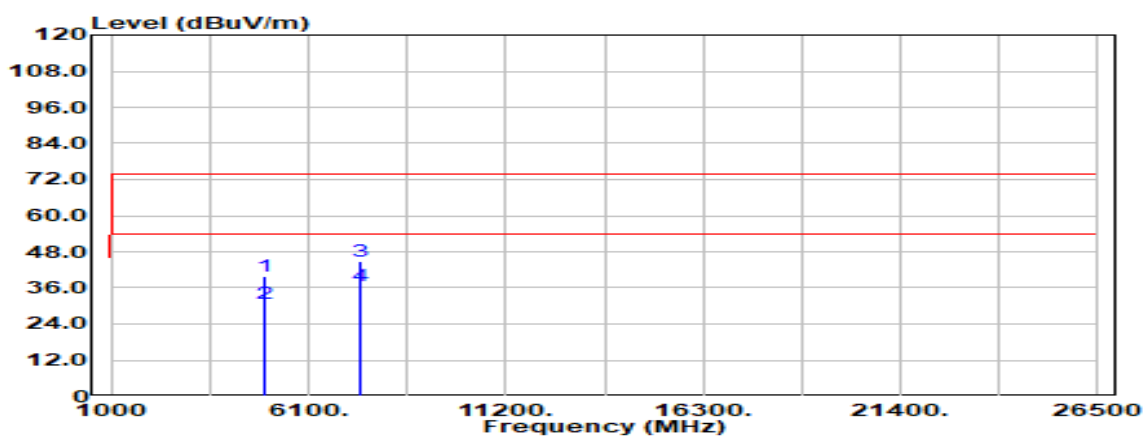

Freq. (MHz)	Detector Mode (PK/QP/AV)	Spectrum Reading Level (dB μ V)	Factor (dB)	Actual FS (dB μ V/m)	Limit @3m (dB μ V/m)	Margin (dB)
4960.000	Peak	32.84	6.91	39.75	74.00	-34.25
4960.000	Average	23.75	6.91	30.66	54.00	-23.34
7440.000	Peak	31.82	13.22	45.04	74.00	-28.96
7440.000	Average	23.41	13.22	36.63	54.00	-17.37
N/A						

Remark:

1. Measuring frequencies from 1 GHz to the 10th harmonic of highest fundamental frequency.

Report No.: TMWK2207002918KR

Test Mode:	8DPSK_EDR-3Mbps High CH	Temp/Hum	24.4(°C)/ 64%RH
Test Item	Harmonic	Test Date	August 10, 2022
Polarize	Horizontal	Test Engineer	Ray Li
Detector	Peak / Average		

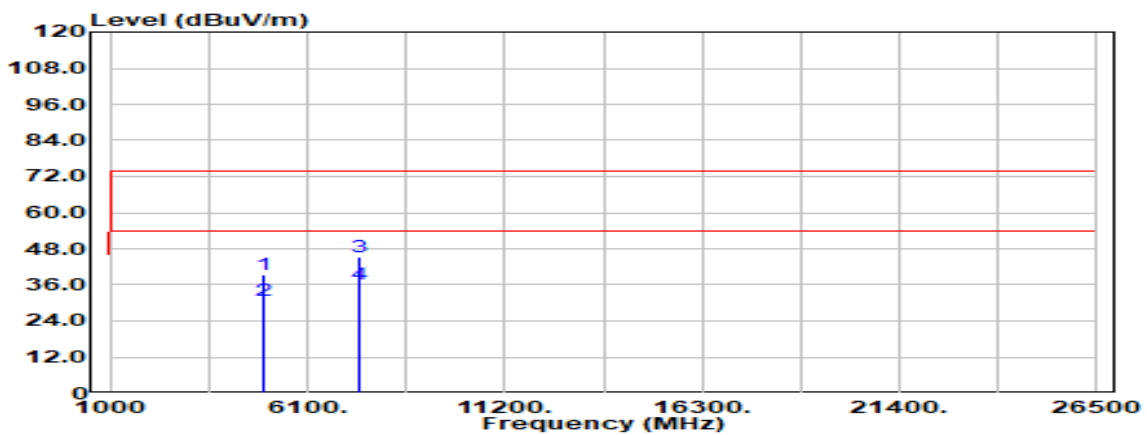

Freq. (MHz)	Detector Mode (PK/QP/AV)	Spectrum Reading Level (dBμV)	Factor (dB)	Actual FS (dBμV/m)	Limit @3m (dBμV/m)	Margin (dB)
4960.000	Peak	32.47	6.91	39.38	74.00	-34.62
4960.000	Average	23.79	6.91	30.70	54.00	-23.30
7440.000	Peak	32.06	13.22	45.28	74.00	-28.72
7440.000	Average	23.21	13.22	36.43	54.00	-17.57
N/A						

Remark:

1. Measuring frequencies from 1 GHz to the 10th harmonic of highest fundamental frequency.

- End of Test Report -