

Report No.: T201104D06-RP4

4.5 RADIATION BANDEDGE AND SPURIOUS EMISSION

4.5.1 Test Limit

FCC according to §15.407, §15.209 and §15.205,

Below 30 MHz

Frequency	Field Strength (microvolts/m)	Magnetic H-Field (microamperes/m)	Measurement Distance (metres)
9-490 kHz	2,400/F (F in kHz)	2,400/F (F in kHz)	300
490-1,705 kHz	24,000/F (F in kHz)	24,000/F (F in kHz)	30
1.705-30 MHz	30	N/A	30

Above 30 MHz

Frequency (MHz)	Field Strength microvolts/m at 3 metres (watts, e.i.r.p.)	
	Transmitters	Receivers
30-88	100 (3 nW)	100 (3 nW)
88-216	150 (6.8 nW)	150 (6.8 nW)
216-960	200 (12 nW)	200 (12 nW)
Above 960	500 (75 nW)	500 (75 nW)

UNII-1 :

For transmitters operating in the band 5150-5250 MHz, all emissions outside the band 5150-5350 MHz shall not exceed -27 dBm/MHz e.i.r.p. However, any unwanted emissions that fall into the band 5250-5350 MHz must be 26 dBc, when measured using a resolution bandwidth between 1 and 5% of the occupied bandwidth, above 5.25 GHz. Otherwise, the transmission is considered as intentional and the devices shall implement dynamic frequency selection (DFS) and transmitter power control (TPC) as per the requirements for the band 5250-5350 MHz

UNII-2a and 2c :

For devices with operating frequencies in the band 5250-5350 MHz but having a channel bandwidth that overlaps the band 5150-5250 MHz, the devices' unwanted emission shall not exceed -27 dBm/MHz e.i.r.p. outside the band 5150-5350 MHz and its power shall comply with the spectral power density for operation within the band 5150-5250 MHz. The device shall be labelled "for indoor use only." Emissions outside the band 5470-5725 MHz shall not exceed -27 dBm/MHz e.i.r.p.

UNII-3:

All emissions shall be limited to a level of -27 dBm/MHz at 75 MHz or more above or below the band edge increasing linearly to 10 dBm/MHz at 25 MHz above or below the band edge, and from 25 MHz above or below the band edge increasing linearly to a level of 15.6 dBm/MHz at 5 MHz above or below the band edge, and from 5 MHz above or below the band edge increasing linearly to a level of 27 dBm/MHz at the band edge.

4.5.2 Test Procedure

Test method Refer as KDB 789033 D02.

1. The EUT is placed on a turntable, Above 1 GHz is 1.5m and below 1 GHz is 0.8m above ground plane. The EUT Configured un accordance with ANSI C63.10: 2013, and the EUT set in a continuous mode.
2. The turntable shall be rotated for 360 degrees to determine the position of maximum emission level. And EUT is set 3m away from the receiving antenna, which is scanned from 1m to 4m above the ground plane to find out the highest emissions. Measurement are made polarized in both the vertical and the horizontal positions with antenna.
3. Span shall wide enough to full capture the emission measured. The SA from 9kHz to 26.5GHz set to the low, Mid and High channels with the EUT transmit.
4. No emission found between lowest internal used/generated frequency to 30MHz (9KHz~30MHz)
5. The SA setting following :
 - (1) Below 1G : RBW = 100kHz, VBW $\geq 3 \times$ RBW, Sweep = Auto, Detector = Peak, Trace = Max hold.
 - (2) Above 1G :
 - (2.1) For Peak measurement : RBW = 1MHz, VBW ≥ 3 RBW, Sweep = Auto, Detector = Peak, Trace = Max hold.
 - (2.2) For Average measurement : RBW = 1MHz, VBW
 - If Duty Cycle $\geq 98\%$, VBW=10Hz.
 - If Duty Cycle $< 98\%$, VBW=1/T.

4.5.3 Test Setup

9kHz ~ 30MHz

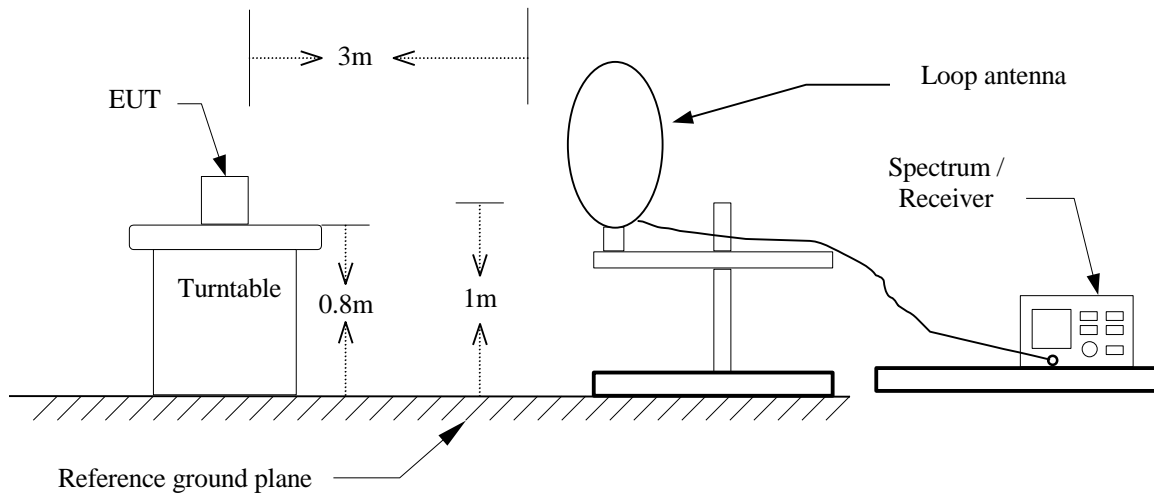

30MHz ~ 1GHz

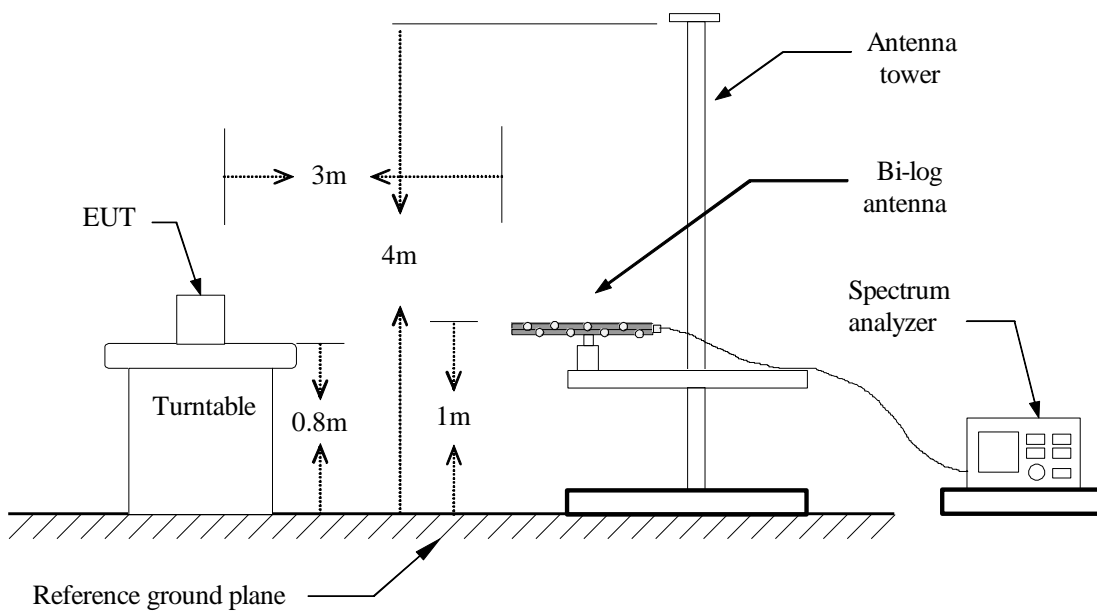

Above 1 GHz

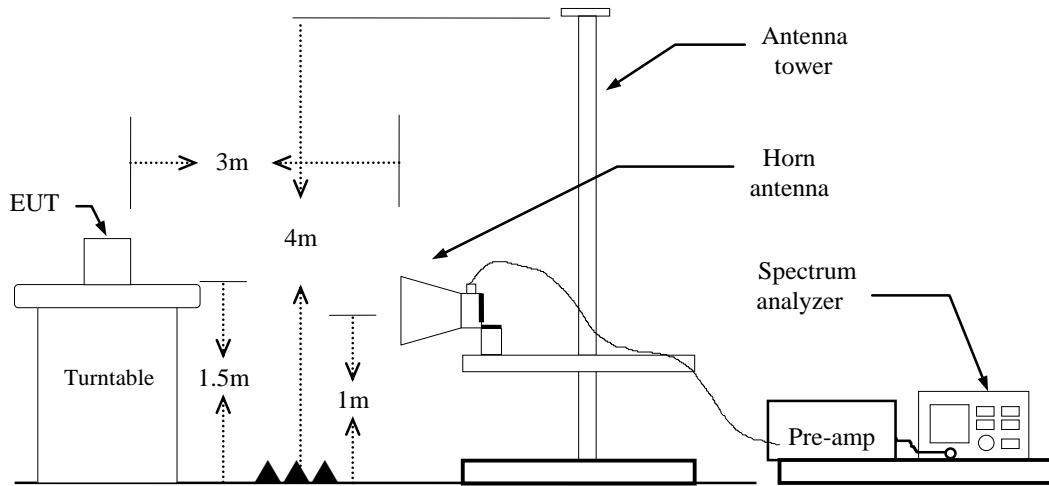

Report No.: T201104D06-RP4

4.5.4 Test Result

Band Edge Test Data

Test Data for UNII-1

Test Mode	IEEE 802.11a / 5180MHZ	Temp/Hum	22.6(°C)/ 63%RH
Test Item	Band Edge	Test Date	November 13, 2020
Polarize	Vertical	Test Engineer	Ray Li
Detector	Peak and Average		

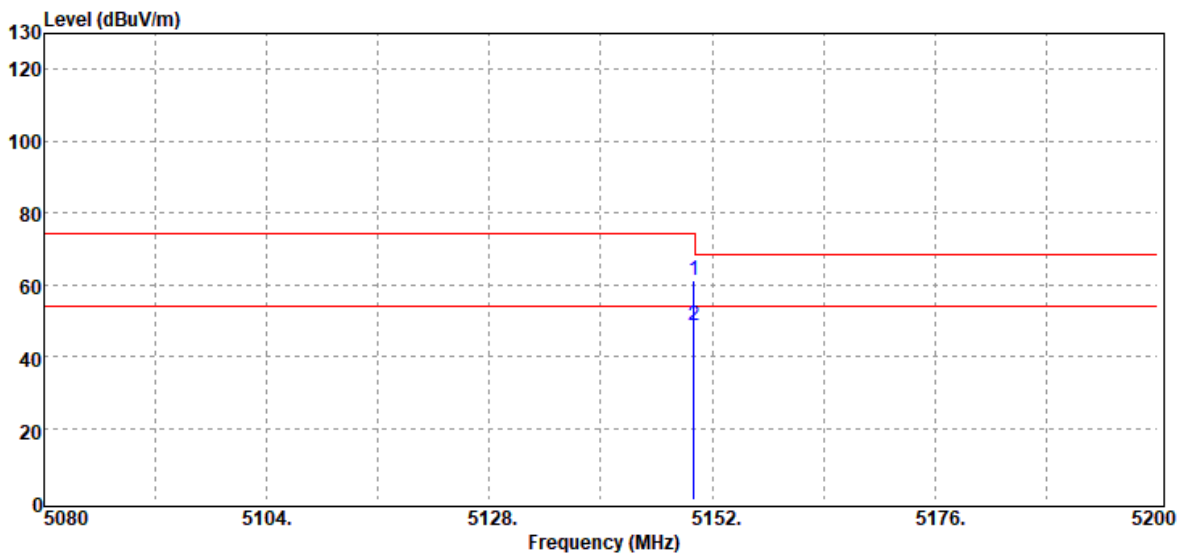

Frequency (MHz)	Detector Mode PK/QP/AV	Spectrum Reading Level dB μ V	Factor dB	Actual FS dB μ V/m	Limit @3m dB μ V/m	Margin dB
5150.00	Peak	70.82	-9.58	61.24	74.00	-12.76
5150.00	Average	58.12	-9.58	48.54	54.00	-5.46

Report No.: T201104D06-RP4

Test Mode	IEEE 802.11a / 5180MHZ	Temp/Hum	22.6(°C)/ 63%RH
Test Item	Band Edge	Test Date	November 13, 2020
Polarize	Horizontal	Test Engineer	Ray Li
Detector	Peak / Average		

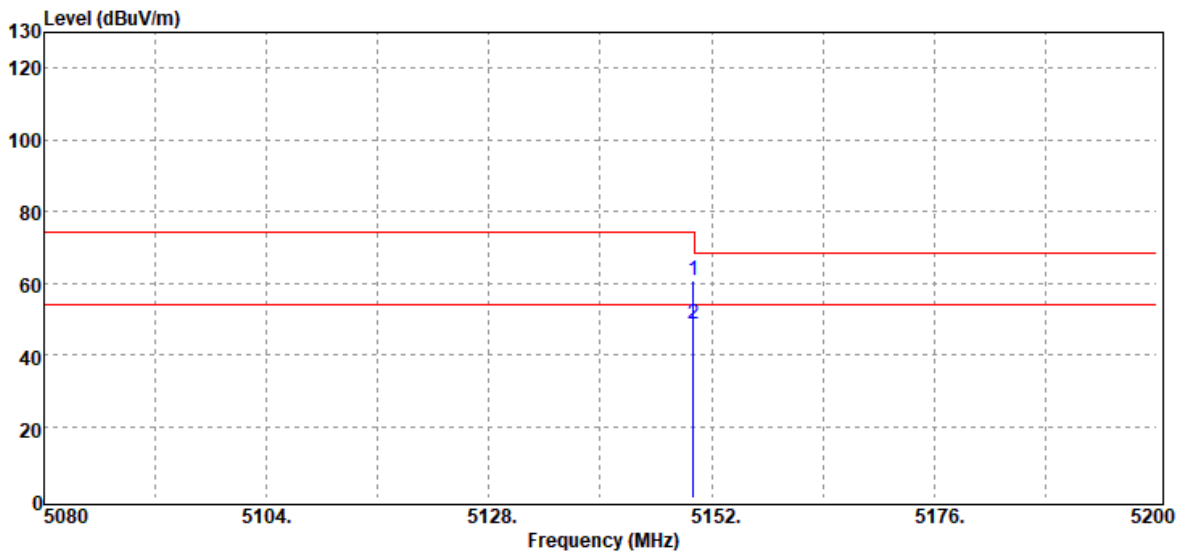

Frequency (MHz)	Detector Mode PK/QP/AV	Spectrum Reading Level dB μ V	Factor dB	Actual FS dB μ V/m	Limit @3m dB μ V/m	Margin dB
5150.00	Peak	70.30	-9.58	60.72	74.00	-13.28
5150.00	Average	58.07	-9.58	48.49	54.00	-5.51

Report No.: T201104D06-RP4

Test Mode	IEEE 802.11n 20 MHz / 5180MHz	Temp/Hum	22.6(°C)/ 63%RH
Test Item	Band Edge	Test Date	November 13, 2020
Polarize	Vertical	Test Engineer	Ray Li
Detector	Peak and Average		

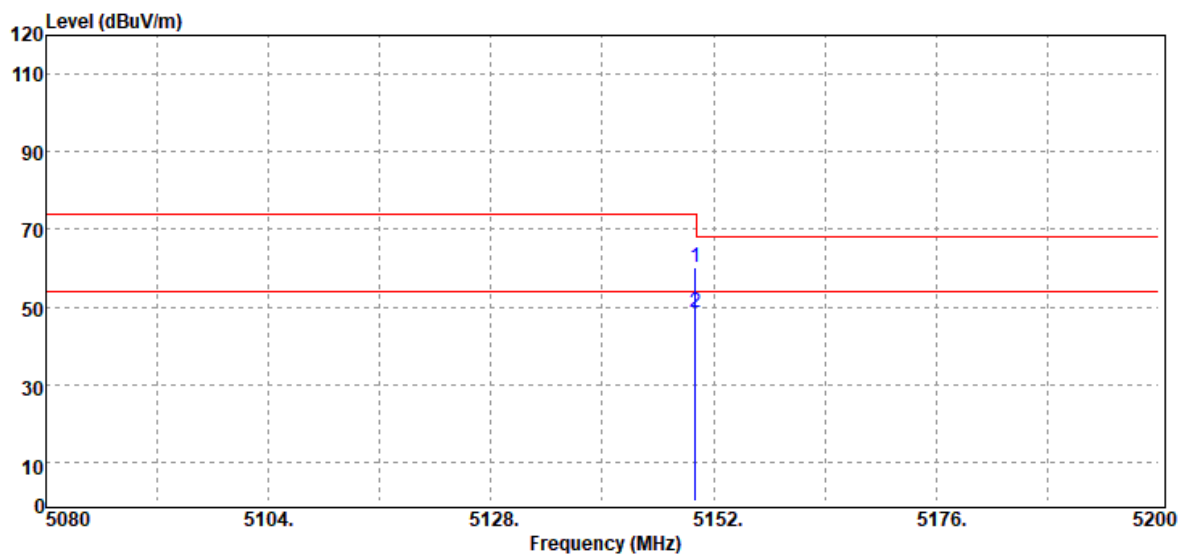

Frequency (MHz)	Detector Mode PK/QP/AV	Spectrum Reading Level dB μ V	Factor dB	Actual FS dB μ V/m	Limit @3m dB μ V/m	Margin dB
5150.00	Peak	69.64	-9.58	60.06	74.00	-13.94
5150.00	Average	58.24	-9.58	48.66	54.00	-5.34

Report No.: T201104D06-RP4

Test Mode	IEEE 802.11n 20 MHz / 5180MHz	Temp/Hum	22.6(°C)/ 63%RH
Test Item	Band Edge	Test Date	November 13, 2020
Polarize	Horizontal	Test Engineer	Ray Li
Detector	Peak and Average		

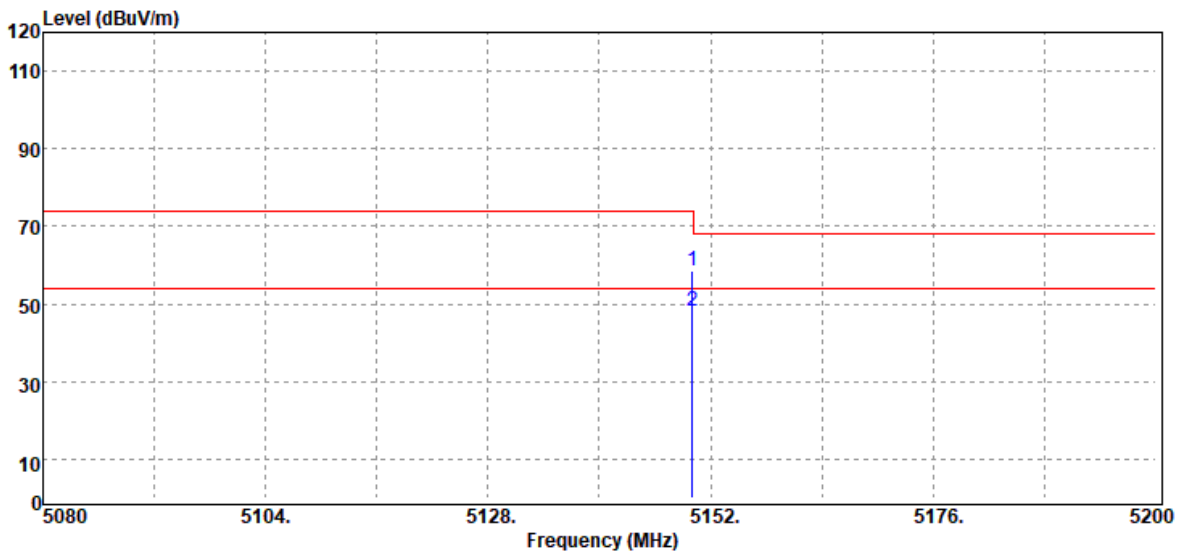

Frequency (MHz)	Detector Mode PK/QP/AV	Spectrum Reading Level dB μ V	Factor dB	Actual FS dB μ V/m	Limit @3m dB μ V/m	Margin dB
5150.00	Peak	67.99	-9.58	58.41	74.00	-15.59
5150.00	Average	57.91	-9.58	48.33	54.00	-5.67

Report No.: T201104D06-RP4

Test Mode	IEEE 802.11n 40 MHz / 5190MHz	Temp/Hum	22.6(°C)/ 63%RH
Test Item	Band Edge	Test Date	November 13, 2020
Polarize	Vertical	Test Engineer	Ray Li
Detector	Peak and Average		

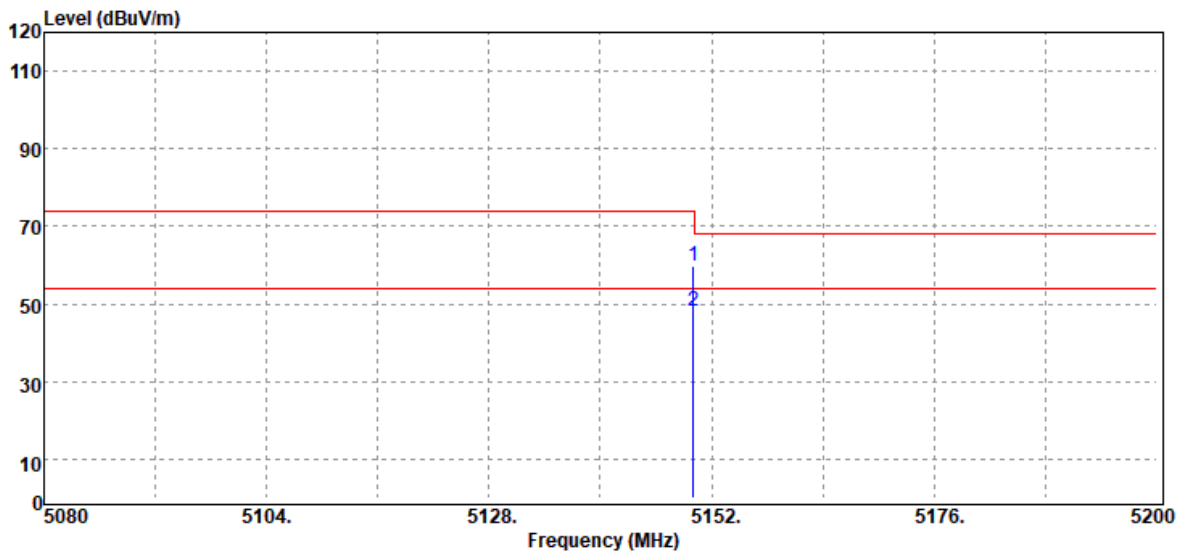

Frequency (MHz)	Detector Mode PK/QP/AV	Spectrum Reading Level dB μ V	Factor dB	Actual FS dB μ V/m	Limit @3m dB μ V/m	Margin dB
5150.00	Peak	69.39	-9.58	59.81	74.00	-14.19
5150.00	Average	57.64	-9.58	48.06	54.00	-5.94

Report No.: T201104D06-RP4

Test Mode	IEEE 802.11n 40 MHz / 5190MHz	Temp/Hum	22.6(°C)/ 63%RH
Test Item	Band Edge	Test Date	November 13, 2020
Polarize	Horizontal	Test Engineer	Ray Li
Detector	Peak and Average		

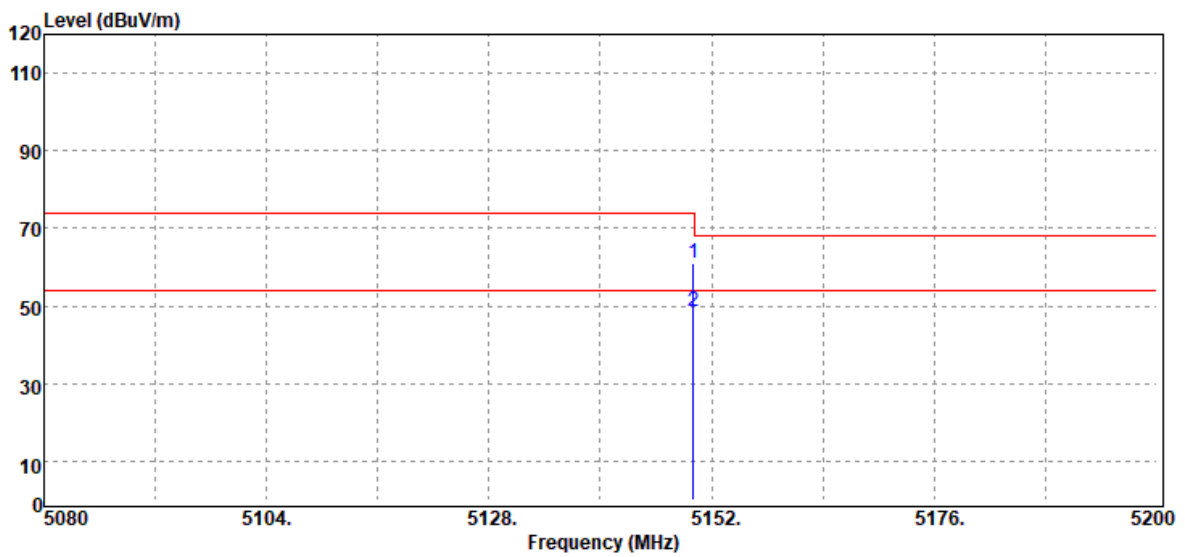

Frequency (MHz)	Detector Mode PK/QP/AV	Spectrum Reading Level dB μ V	Factor dB	Actual FS dB μ V/m	Limit @3m dB μ V/m	Margin dB
5150.00	Peak	70.51	-9.58	60.93	74.00	-13.07
5150.00	Average	58.10	-9.58	48.52	54.00	-5.48

Report No.: T201104D06-RP4

Test Mode	IEEE 802.11ac VHT80 / 5210MHZ	Temp/Hum	22.6(°C)/ 65%RH
Test Item	Band Edge	Test Date	November 18, 2020
Polarize	Vertical	Test Engineer	Ray Li
Detector	Peak and Average		

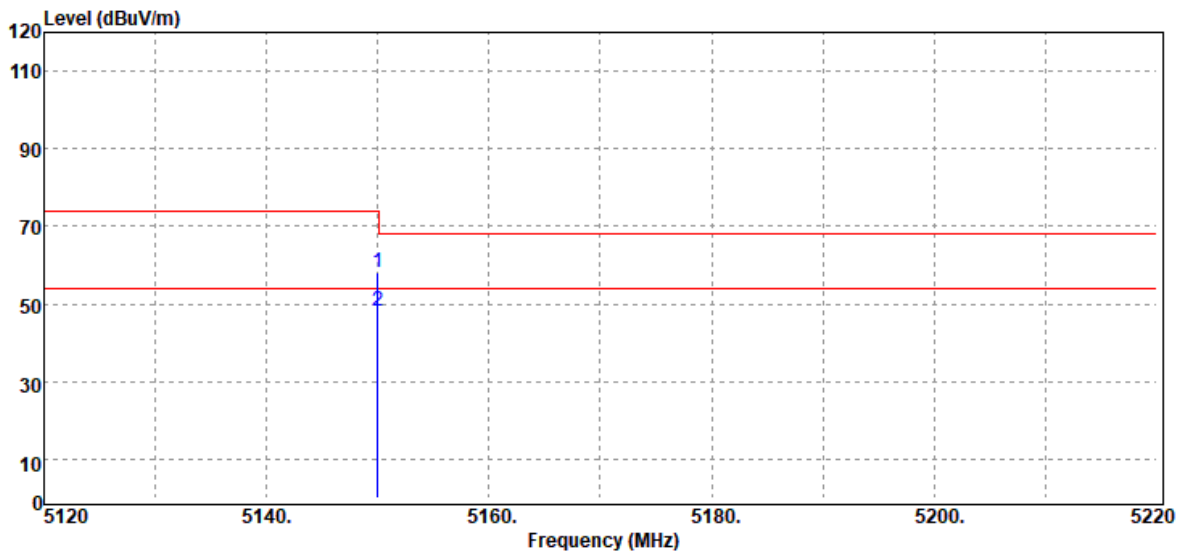

Frequency (MHz)	Detector Mode PK/QP/AV	Spectrum Reading Level dB μ V	Factor dB	Actual FS dB μ V/m	Limit @3m dB μ V/m	Margin dB
5150.00	Peak	67.90	-9.58	58.32	74.00	-15.68
5150.00	Average	57.82	-9.58	48.24	54.00	-5.76

Report No.: T201104D06-RP4

Test Mode	IEEE 802.11ac VHT80 / 5210MHZ	Temp/Hum	22.6(°C)/ 65%RH
Test Item	Band Edge	Test Date	November 18, 2020
Polarize	Horizontal	Test Engineer	Ray Li
Detector	Peak and Average		

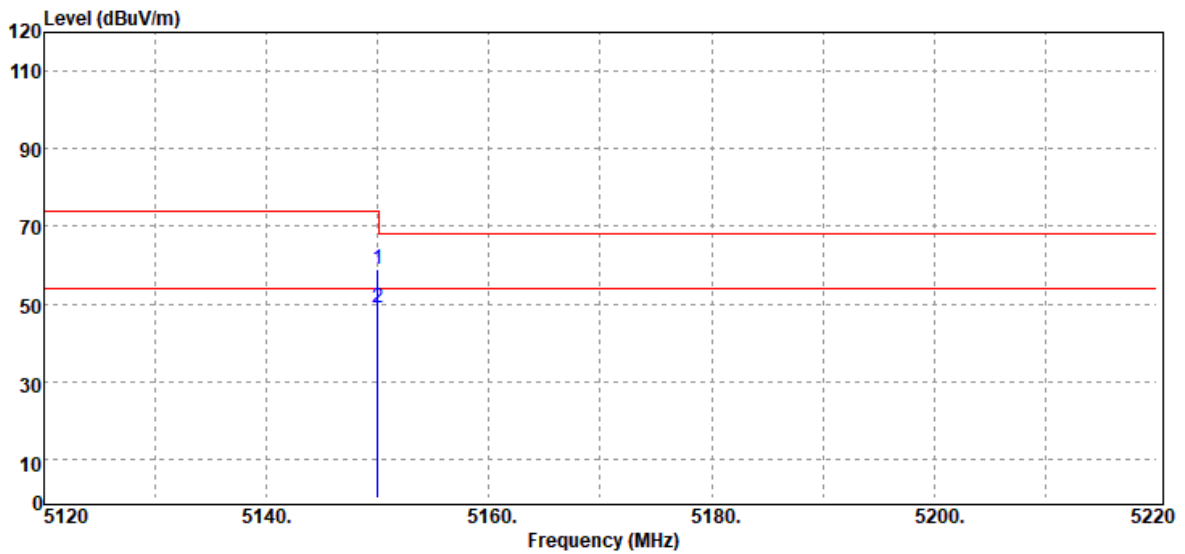

Frequency (MHz)	Detector Mode PK/QP/AV	Spectrum Reading Level dB μ V	Factor dB	Actual FS dB μ V/m	Limit @3m dB μ V/m	Margin dB
5150.00	Peak	68.52	-9.58	58.94	74.00	-15.06
5150.00	Average	58.41	-9.58	48.83	54.00	-5.17

Test Data for UNII-2a

Test Mode	IEEE 802.11a / 5320 MHz	Temp/Hum	22.6(°C)/ 63%RH
Test Item	Band Edge	Test Date	November 13, 2020
Polarize	Vertical	Test Engineer	Ray Li
Detector	Peak and Average		

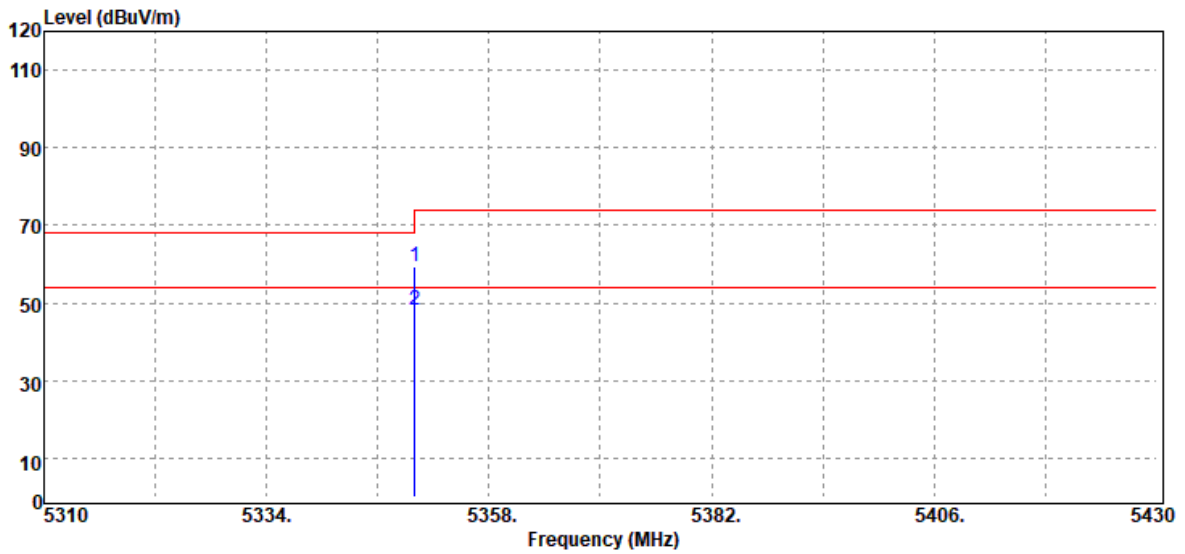

Frequency (MHz)	Detector Mode PK/QP/AV	Spectrum Reading Level dB μ V	Factor dB	Actual FS dB μ V/m	Limit @3m dB μ V/m	Margin dB
5350.00	Peak	69.10	-9.60	59.50	74.00	-14.50
5350.00	Average	57.69	-9.60	48.09	54.00	-5.91

Report No.: T201104D06-RP4

Test Mode	IEEE 802.11a / 5320 MHz	Temp/Hum	22.6(°C)/ 63%RH
Test Item	Band Edge	Test Date	November 13, 2020
Polarize	Horizontal	Test Engineer	Ray Li
Detector	Peak and Average		

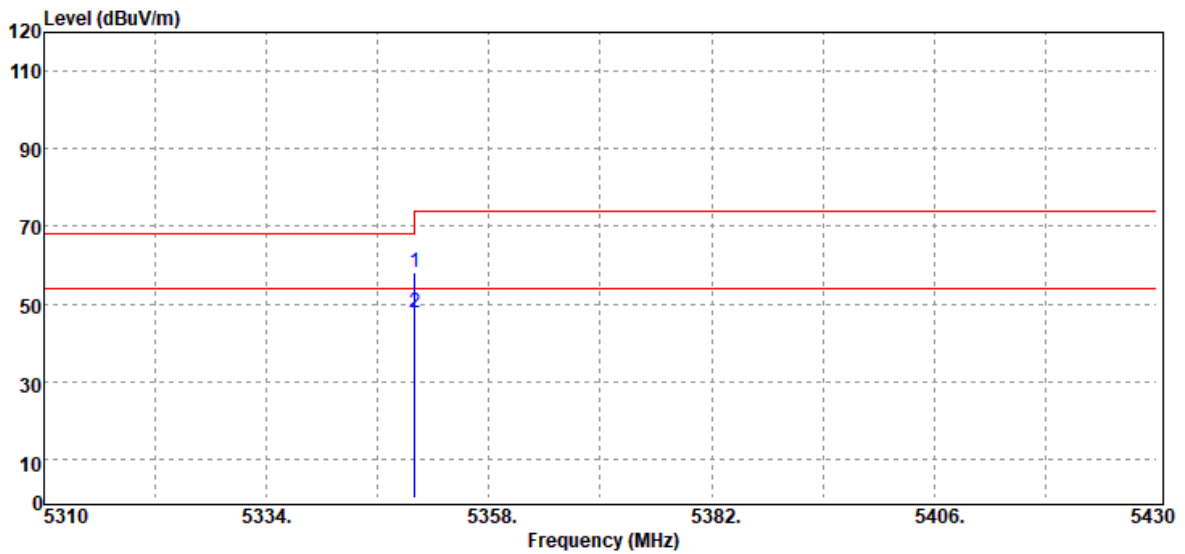

Frequency (MHz)	Detector Mode PK/QP/AV	Spectrum Reading Level dBμV	Factor dB	Actual FS dBμV/m	Limit @3m dBμV/m	Margin dB
5350.00	Peak	67.74	-9.60	58.14	74.00	-15.86
5350.00	Average	57.34	-9.60	47.74	54.00	-6.26

Report No.: T201104D06-RP4

Test Mode	IEEE 802.11n 20 MHz / 5320MHz	Temp/Hum	22.6(°C)/ 63%RH
Test Item	Band Edge	Test Date	November 13, 2020
Polarize	Vertical	Test Engineer	Ray Li
Detector	Peak and Average		

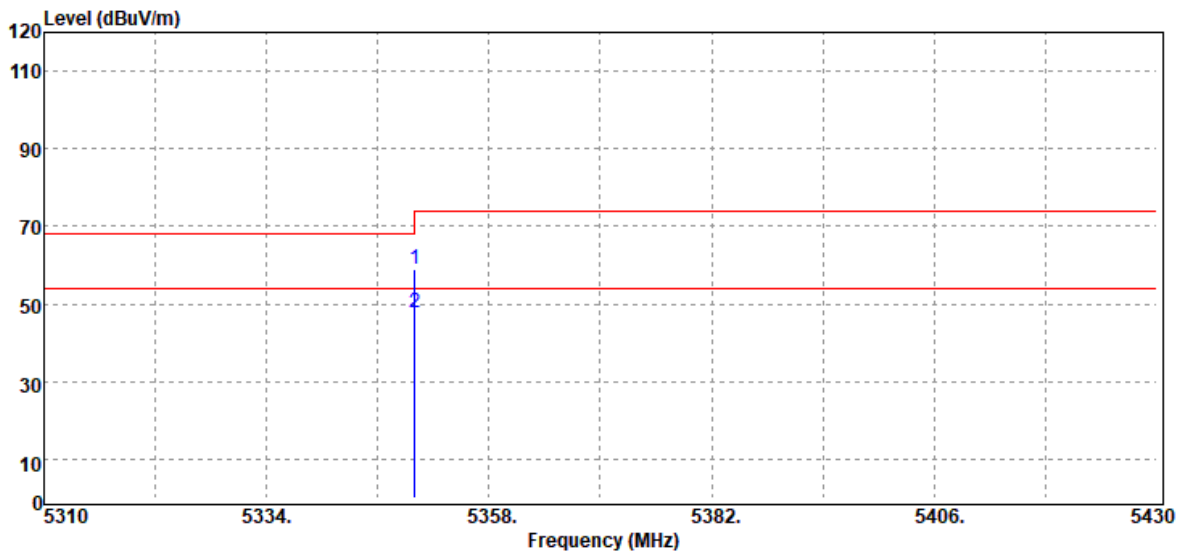

Frequency (MHz)	Detector Mode PK/QP/AV	Spectrum Reading Level dB μ V	Factor dB	Actual FS dB μ V/m	Limit @3m dB μ V/m	Margin dB
5350.00	Peak	68.49	-9.60	58.89	74.00	-15.11
5350.00	Average	57.38	-9.60	47.78	54.00	-6.22

Test Mode	IEEE 802.11n 20 MHz / 5320MHz	Temp/Hum	22.6(°C)/ 63%RH
Test Item	Band Edge	Test Date	November 13, 2020
Polarize	Horizontal	Test Engineer	Ray Li
Detector	Peak and Average		

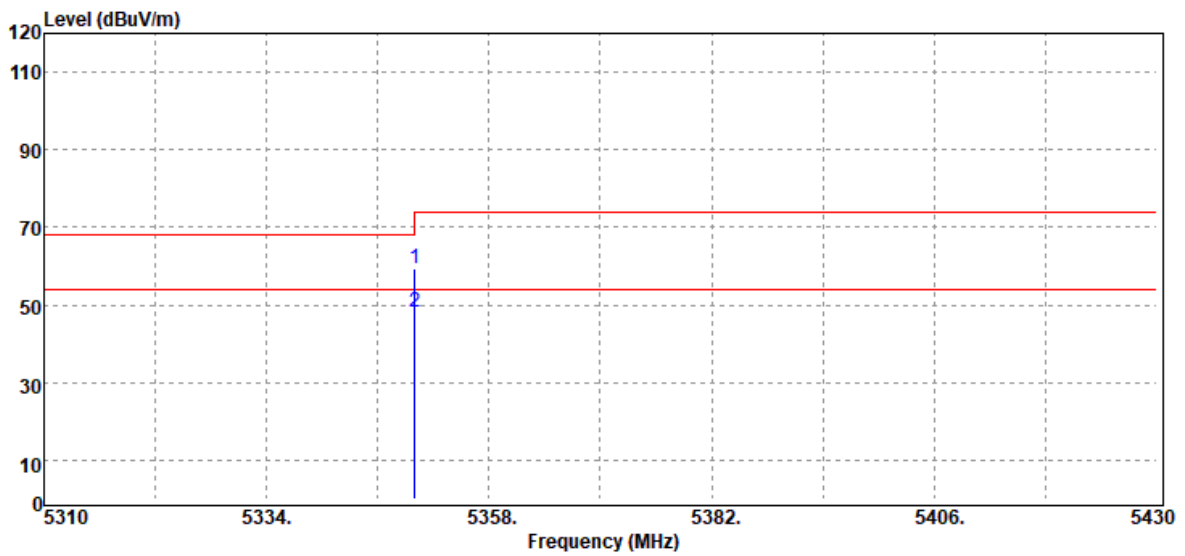

Frequency (MHz)	Detector Mode PK/QP/AV	Spectrum Reading Level dB μ V	Factor dB	Actual FS dB μ V/m	Limit @3m dB μ V/m	Margin dB
5350.00	Peak	69.15	-9.60	59.55	74.00	-14.45
5350.00	Average	57.75	-9.60	48.15	54.00	-5.85

Test Mode	IEEE 802.11n 40 MHz / 5310MHz	Temp/Hum	22.6(°C)/ 63%RH
Test Item	Band Edge	Test Date	November 13, 2020
Polarize	Vertical	Test Engineer	Ray Li
Detector	Peak and Average		

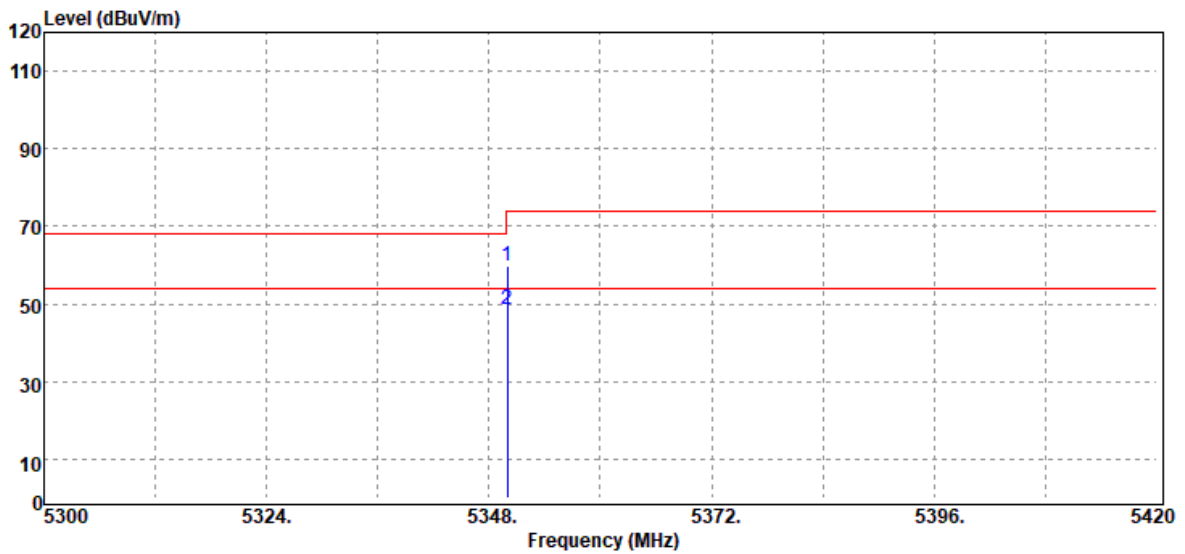

Frequency (MHz)	Detector Mode PK/QP/AV	Spectrum Reading Level dB μ V	Factor dB	Actual FS dB μ V/m	Limit @3m dB μ V/m	Margin dB
5350.00	Peak	69.20	-9.60	59.60	74.00	-14.40
5350.00	Average	58.20	-9.60	48.60	54.00	-5.40

Report No.: T201104D06-RP4

Test Mode	IEEE 802.11n 40 MHz / 5310MHz	Temp/Hum	22.6(°C)/ 63%RH
Test Item	Band Edge	Test Date	November 13, 2020
Polarize	Horizontal	Test Engineer	Ray Li
Detector	Peak and Average		

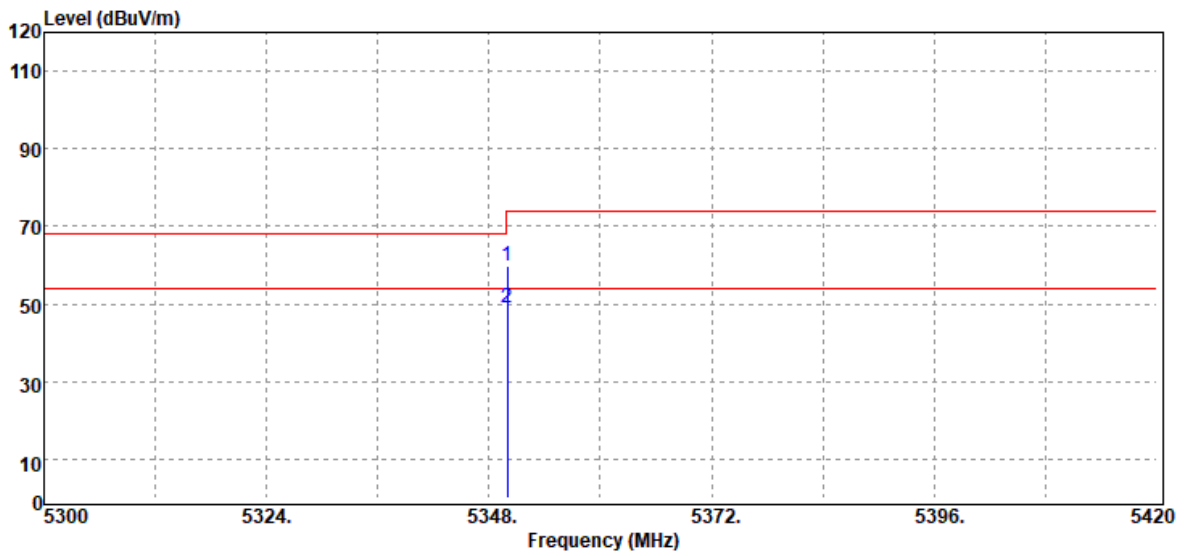

Frequency (MHz)	Detector Mode PK/QP/AV	Spectrum Reading Level dB μ V	Factor dB	Actual FS dB μ V/m	Limit @3m dB μ V/m	Margin dB
5350.00	Peak	69.28	-9.60	59.68	74.00	-14.32
5350.00	Average	58.68	-9.60	49.08	54.00	-4.92

Report No.: T201104D06-RP4

Test Mode	IEEE 802.11ac VHT80 / 5290MHz	Temp/Hum	22.6(°C)/ 65%RH
Test Item	Band Edge	Test Date	November 18, 2020
Polarize	Vertical	Test Engineer	Ray Li
Detector	Peak and Average		

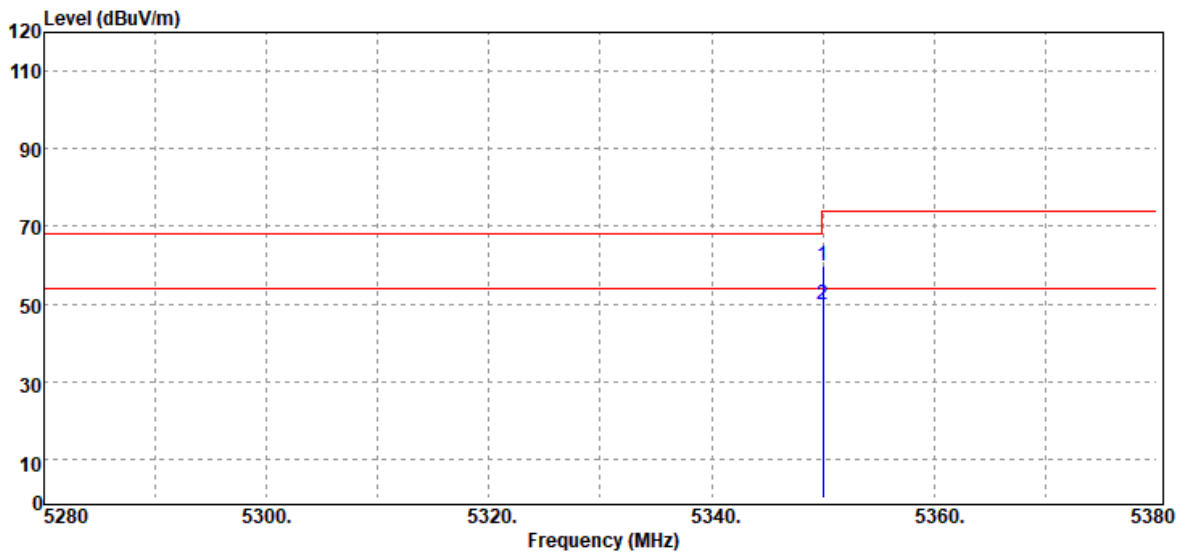

Frequency (MHz)	Detector Mode PK/QP/AV	Spectrum Reading Level dB μ V	Factor dB	Actual FS dB μ V/m	Limit @3m dB μ V/m	Margin dB
5350.00	Peak	69.30	-9.60	59.70	74.00	-14.30
5350.00	Average	59.31	-9.60	49.71	54.00	-4.29

Report No.: T201104D06-RP4

Test Mode	IEEE 802.11ac VHT80 / 5290MHz	Temp/Hum	22.6(°C)/ 65%RH
Test Item	Band Edge	Test Date	November 18, 2020
Polarize	Horizontal	Test Engineer	Ray Li
Detector	Peak and Average		

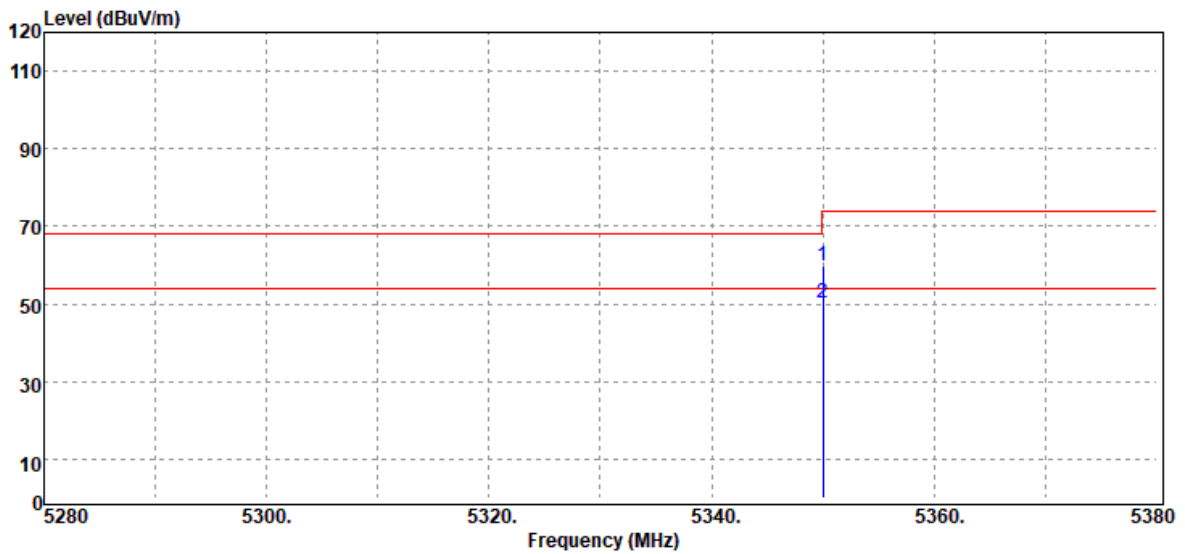

Frequency (MHz)	Detector Mode PK/QP/AV	Spectrum Reading Level dB μ V	Factor dB	Actual FS dB μ V/m	Limit @3m dB μ V/m	Margin dB
5350.00	Peak	69.46	-9.60	59.86	74.00	-14.14
5350.00	Average	59.89	-9.60	50.29	54.00	-3.71

Report No.: T201104D06-RP4

Test Data for UNII-2c

Test Mode	IEEE 802.11a / 5500MHz	Temp/Hum	22.6(°C)/ 63%RH
Test Item	Band Edge	Test Date	November 13, 2020
Polarize	Vertical	Test Engineer	Ray Li
Detector	Peak and Average		

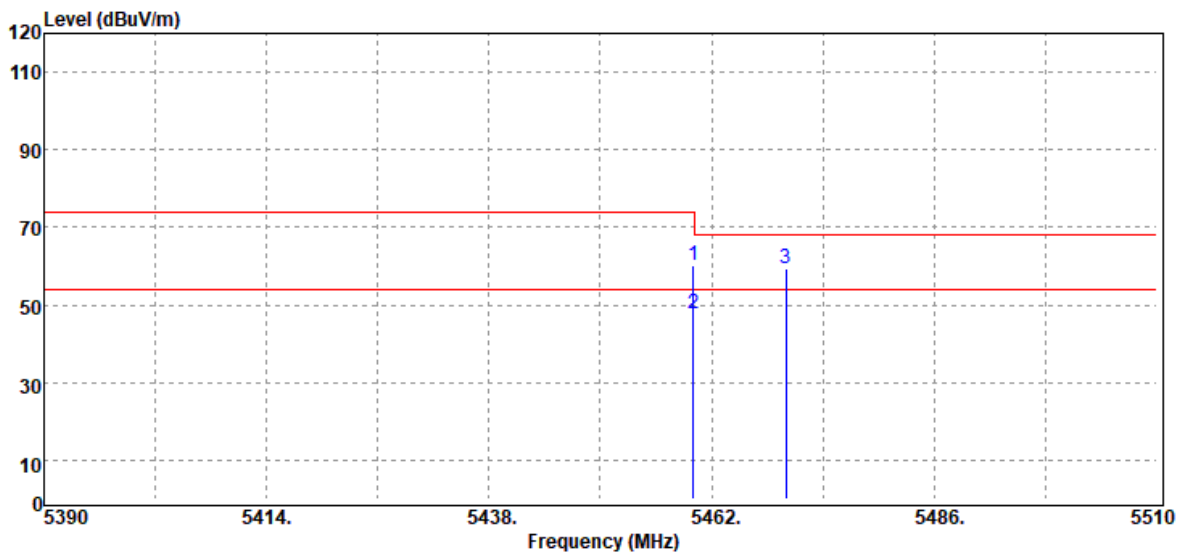

Frequency (MHz)	Detector Mode PK/QP/AV	Spectrum Reading Level dBµV	Factor dB	Actual FS dBµV/m	Limit @3m dBµV/m	Margin dB
5460.00	Peak	69.66	-9.47	60.19	74.00	-13.81
5460.00	Average	57.42	-9.47	47.95	54.00	-6.05
5470.00	Peak	68.98	-9.43	59.55	68.20	-8.65

Test Mode	IEEE 802.11a / 5500MHz	Temp/Hum	22.6(°C)/ 63%RH
Test Item	Band Edge	Test Date	November 13, 2020
Polarize	Horizontal	Test Engineer	Ray Li
Detector	Peak and Average		

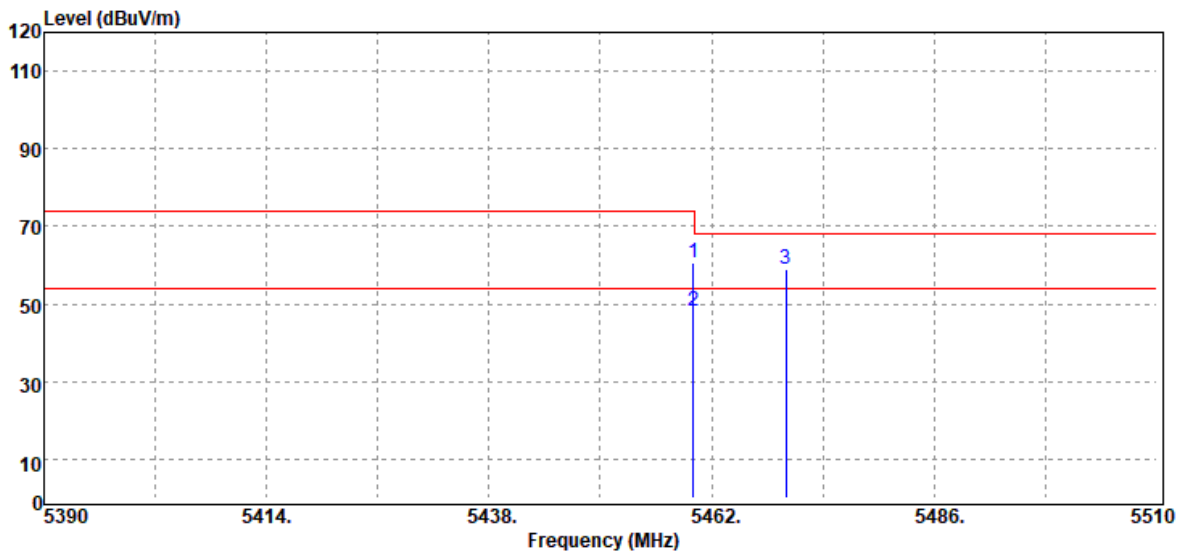

Frequency (MHz)	Detector Mode PK/QP/AV	Spectrum Reading Level dB μ V	Factor dB	Actual FS dB μ V/m	Limit @3m dB μ V/m	Margin dB
5460.00	Peak	70.17	-9.47	60.70	74.00	-13.30
5460.00	Average	57.58	-9.47	48.11	54.00	-5.89
5470.00	Peak	68.57	-9.43	59.14	68.20	-9.06

Report No.: T201104D06-RP4

Test Mode	IEEE 802.11a / 5700 MHz	Temp/Hum	22.6(°C)/ 63%RH
Test Item	Band Edge	Test Date	November 13, 2020
Polarize	Vertical	Test Engineer	Ray Li
Detector	Peak		

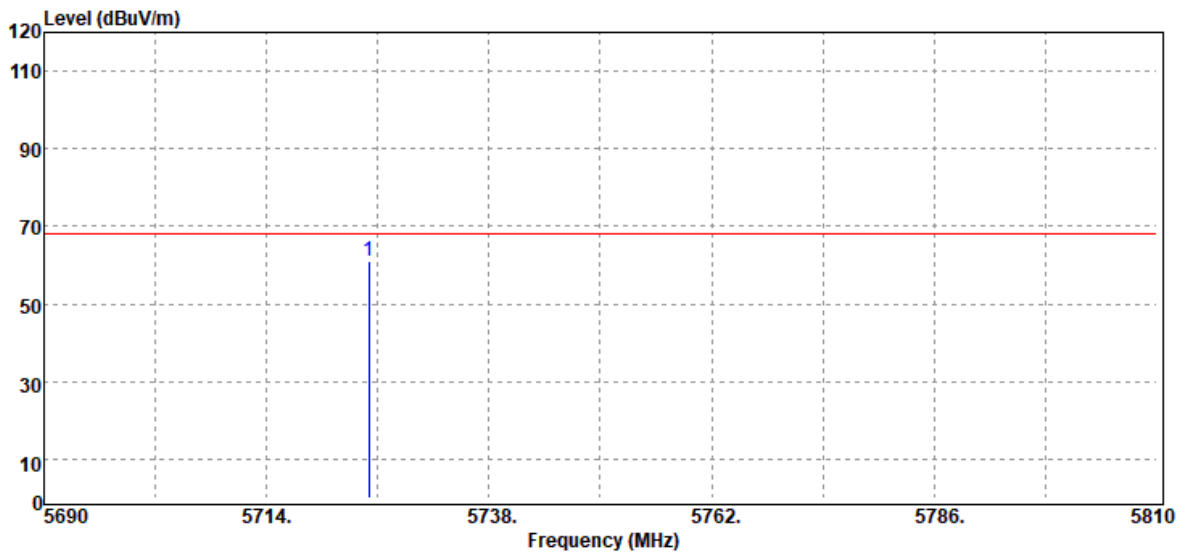

Frequency (MHz)	Detector Mode PK/QP/AV	Spectrum Reading Level dBuV	Factor dB	Actual FS dBuV/m	Limit @3m dBuV/m	Margin dB
5725.00	Peak	69.58	-8.57	61.01	68.20	-7.19

Report No.: T201104D06-RP4

Test Mode	IEEE 802.11a / 5700 MHz	Temp/Hum	22.6(°C)/ 63%RH
Test Item	Band Edge	Test Date	November 13, 2020
Polarize	Horizontal	Test Engineer	Ray Li
Detector	Peak		

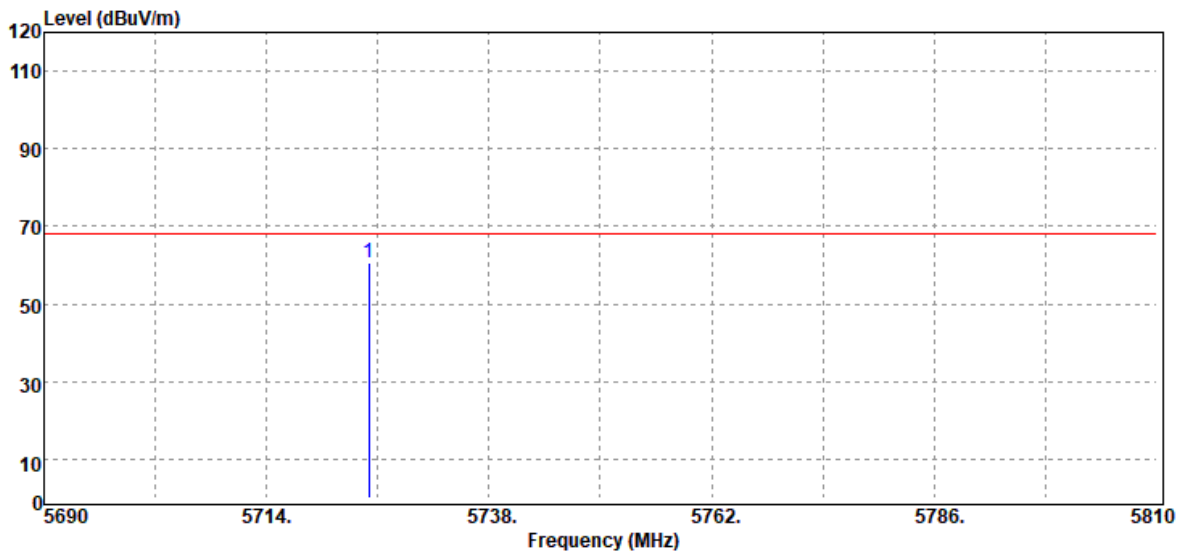

Frequency (MHz)	Detector Mode PK/QP/AV	Spectrum Reading Level dBμV	Factor dB	Actual FS dBμV/m	Limit @3m dBμV/m	Margin dB
5725.00	Peak	69.13	-8.57	60.56	68.20	-7.64

Test Mode	IEEE 802.11n 20 MHz / 5500MHz	Temp/Hum	22.6(°C)/ 63%RH
Test Item	Band Edge	Test Date	November 13, 2020
Polarize	Vertical	Test Engineer	Ray Li
Detector	Peak and Average		

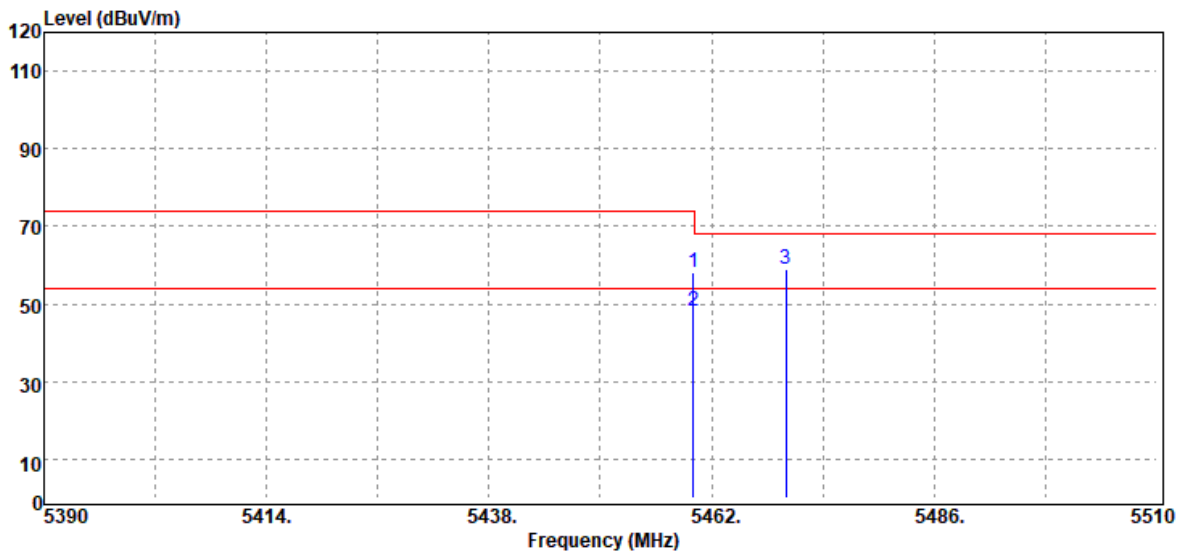

Frequency (MHz)	Detector Mode PK/QP/AV	Spectrum Reading Level dBμV	Factor dB	Actual FS dBμV/m	Limit @3m dBμV/m	Margin dB
5460.00	Peak	67.54	-9.47	58.07	74.00	-15.93
5460.00	Average	57.55	-9.47	48.08	54.00	-5.92
5470.00	Peak	68.19	-9.43	58.76	68.20	-9.44

Report No.: T201104D06-RP4

Test Mode	IEEE 802.11n 20 MHz / 5500MHz	Temp/Hum	22.6(°C)/ 63%RH
Test Item	Band Edge	Test Date	November 13, 2020
Polarize	Horizontal	Test Engineer	Ray Li
Detector	Peak and Average		

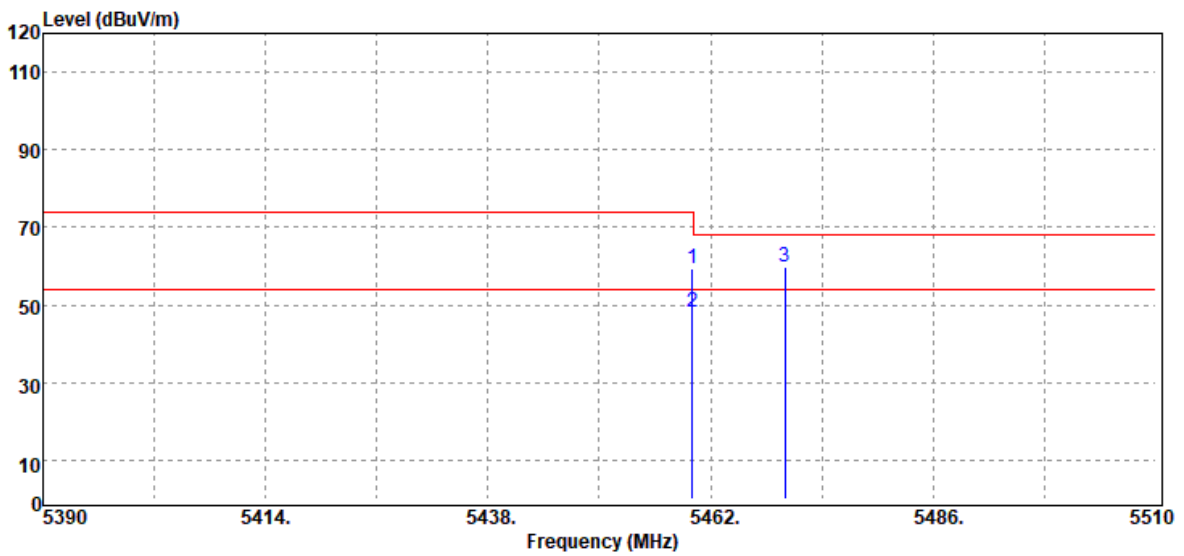

Frequency (MHz)	Detector Mode PK/QP/AV	Spectrum Reading Level dB μ V	Factor dB	Actual FS dB μ V/m	Limit @3m dB μ V/m	Margin dB
5460.00	Peak	68.83	-9.47	59.36	74.00	-14.64
5460.00	Average	57.81	-9.47	48.34	54.00	-5.66
5470.00	Peak	69.41	-9.43	59.98	68.20	-8.22

Report No.: T201104D06-RP4

Test Mode	IEEE 802.11n 20 MHz / 5700 MHz	Temperature	22.6(°C)/ 63%RH
Test Item	Band Edge	Test Date	November 13, 2020
Polarize	Vertical	Test Engineer	Ray Li
Detector	Peak		

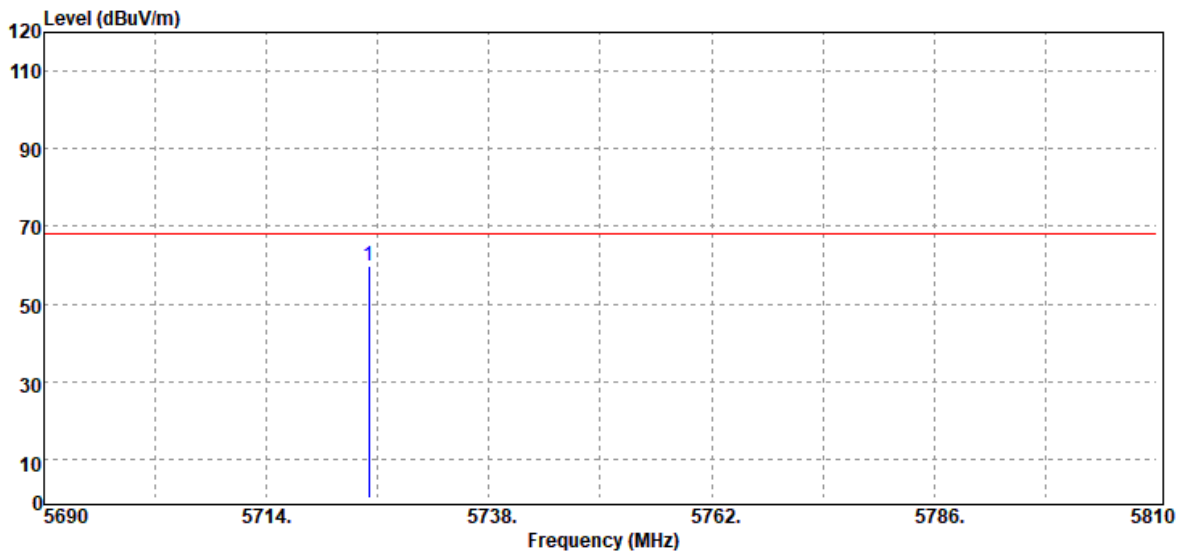

Frequency (MHz)	Detector Mode PK/QP/AV	Spectrum Reading Level dB μ V	Factor dB	Actual FS dB μ V/m	Limit @3m dB μ V/m	Margin dB
5725.00	Peak	68.37	-8.57	59.80	68.20	-8.40

Test Mode	IEEE 802.11n 20 MHz / 5700 MHz	Temperature	22.6(°C)/ 63%RH
Test Item	Band Edge	Test Date	November 13, 2020
Polarize	Horizontal	Test Engineer	Ray Li
Detector	Peak		

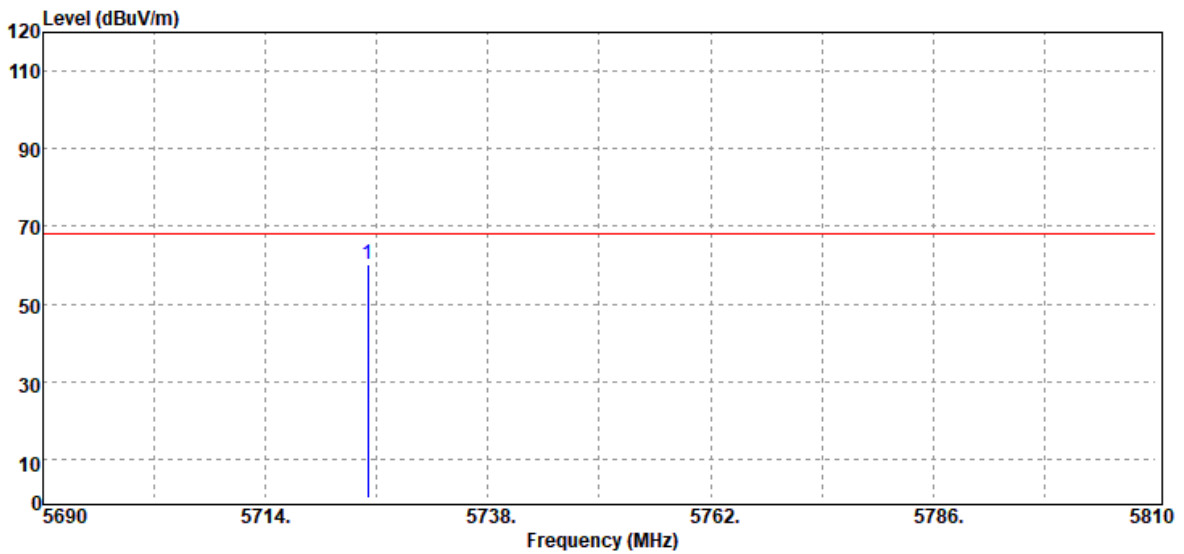

Frequency (MHz)	Detector Mode PK/QP/AV	Spectrum Reading Level dB μ V	Factor dB	Actual FS dB μ V/m	Limit @3m dB μ V/m	Margin dB
5725.00	Peak	68.77	-8.57	60.20	68.20	-8.00

Test Mode	IEEE 802.11n 40 MHz / 5510 MHz	Temp/Hum	22.6(°C)/ 63%RH
Test Item	Band Edge	Test Date	November 13, 2020
Polarize	Vertical	Test Engineer	Ray Li
Detector	Peak and Average		

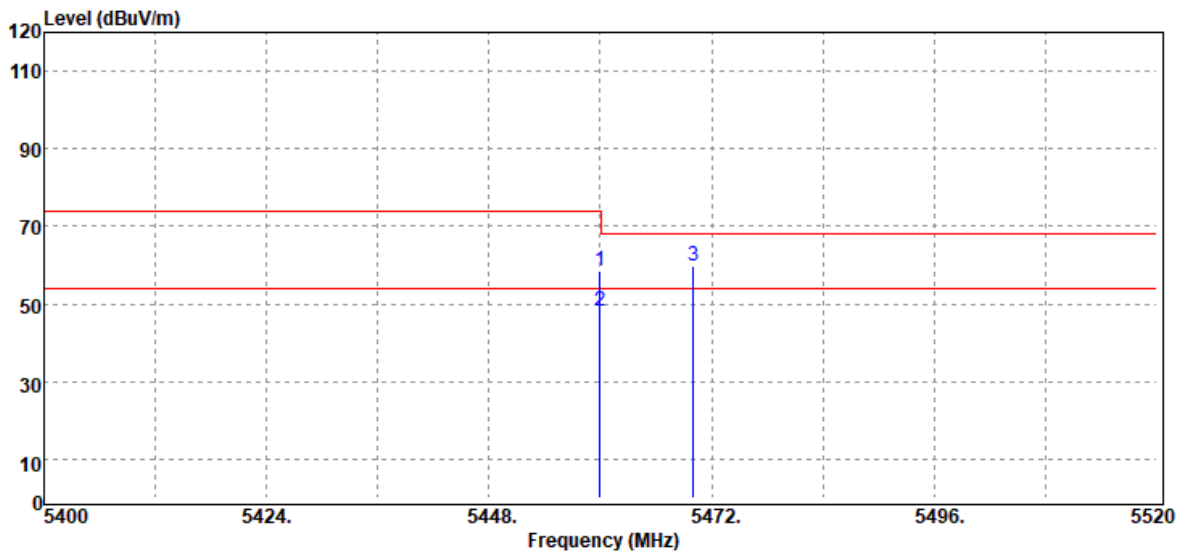

Frequency (MHz)	Detector Mode PK/QP/AV	Spectrum Reading Level dB μ V	Factor dB	Actual FS dB μ V/m	Limit @3m dB μ V/m	Margin dB
5460.00	Peak	67.99	-9.47	58.52	74.00	-15.48
5460.00	Average	57.58	-9.47	48.11	54.00	-5.89
5470.00	Peak	69.14	-9.43	59.71	68.20	-8.49

Report No.: T201104D06-RP4

Test Mode	IEEE 802.11n 40 MHz / 5510 MHz	Temp/Hum	22.6(°C)/ 63%RH
Test Item	Band Edge	Test Date	November 13, 2020
Polarize	Horizontal	Test Engineer	Ray Li
Detector	Peak and Average		

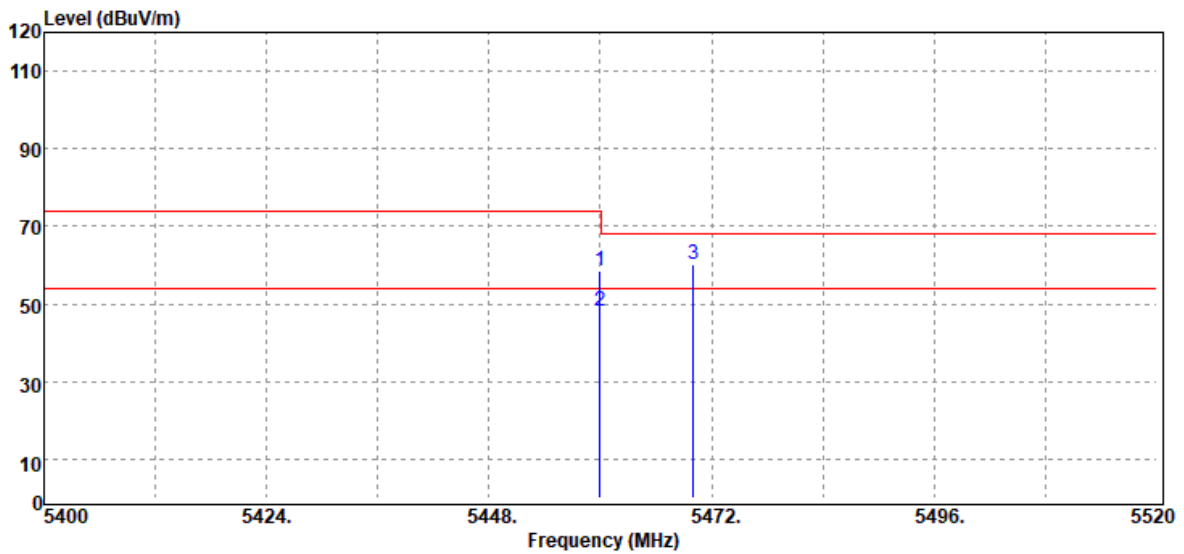

Frequency (MHz)	Detector Mode PK/QP/AV	Spectrum Reading Level dB μ V	Factor dB	Actual FS dB μ V/m	Limit @3m dB μ V/m	Margin dB
5460.00	Peak	67.97	-9.47	58.50	74.00	-15.50
5460.00	Average	57.60	-9.47	48.13	54.00	-5.87
5470.00	Peak	69.46	-9.43	60.03	68.20	-8.17

Report No.: T201104D06-RP4

Test Mode	IEEE 802.11n 40 MHz / 5670 MHz	Temp/Hum	22.6(°C)/ 63%RH
Test Item	Band Edge	Test Date	November 13, 2020
Polarize	Vertical	Test Engineer	Ray Li
Detector	Peak		

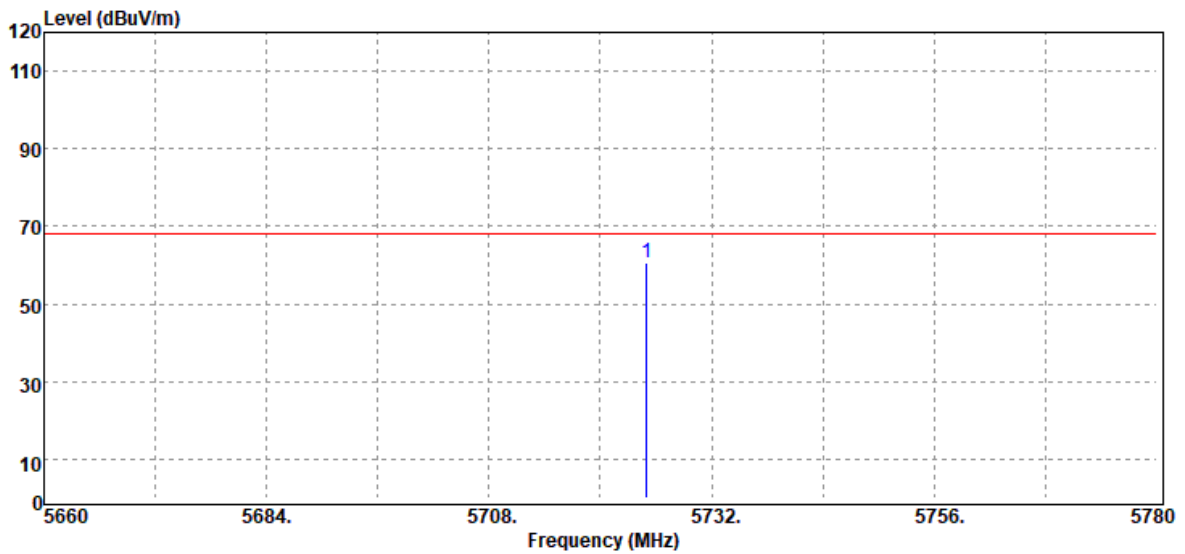

Frequency (MHz)	Detector Mode PK/QP/AV	Spectrum Reading Level dB μ V	Factor dB	Actual FS dB μ V/m	Limit @3m dB μ V/m	Margin dB
5725.00	Peak	69.12	-8.57	60.55	68.20	-7.65

Test Mode	IEEE 802.11n 40 MHz / 5670 MHz	Temp/Hum	22.6(°C)/ 63%RH
Test Item	Band Edge	Test Date	November 13, 2020
Polarize	Horizontal	Test Engineer	Ray Li
Detector	Peak		

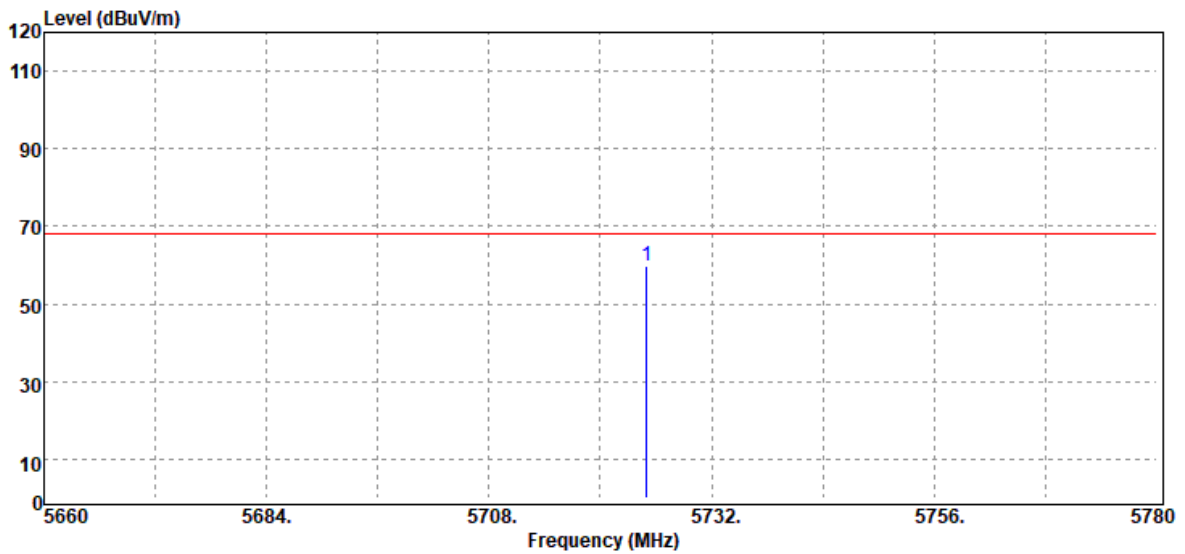

Frequency (MHz)	Detector Mode PK/QP/AV	Spectrum Reading Level dB μ V	Factor dB	Actual FS dB μ V/m	Limit @3m dB μ V/m	Margin dB
5725.00	Peak	68.47	-8.57	59.90	68.20	-8.30

Report No.: T201104D06-RP4

Test Mode	IEEE 802.11ac VHT80 / 5530 MHz	Temp/Hum	22.6(°C)/ 65%RH
Test Item	Band Edge	Test Date	November 18, 2020
Polarize	Vertical	Test Engineer	Ray Li
Detector	Peak and Average		

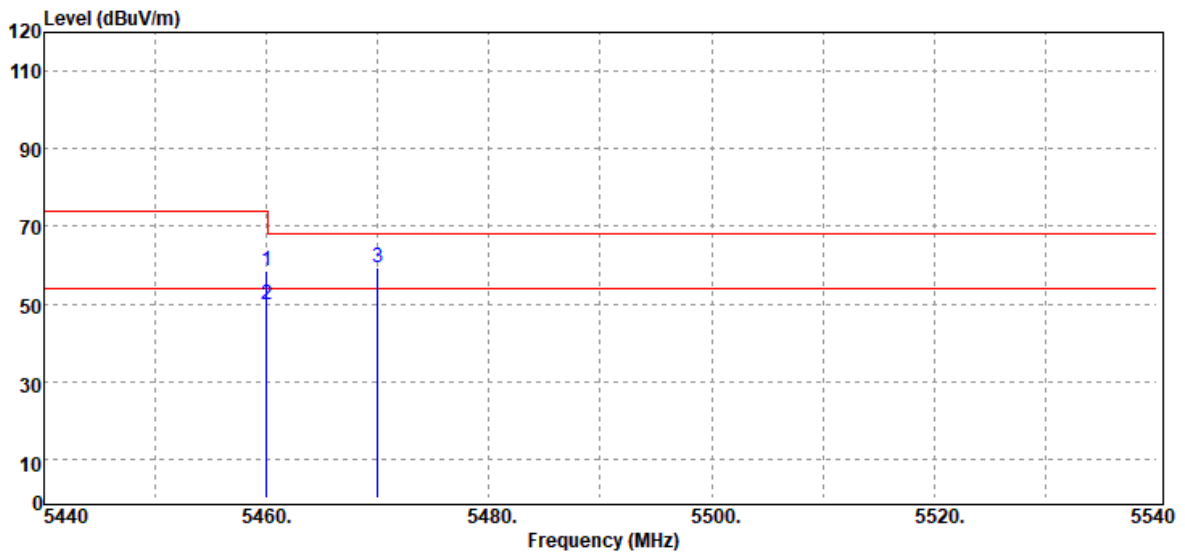

Frequency (MHz)	Detector Mode PK/QP/AV	Spectrum Reading Level dB μ V	Factor dB	Actual FS dB μ V/m	Limit @3m dB μ V/m	Margin dB
5460.00	Peak	68.22	-9.47	58.75	74.00	-15.25
5460.00	Average	59.28	-9.47	49.81	54.00	-4.19
5470.00	Peak	68.63	-9.43	59.20	68.20	-9.00

Report No.: T201104D06-RP4

Test Mode	IEEE 802.11ac VHT80 / 5530 MHz	Temp/Hum	22.6(°C)/ 65%RH
Test Item	Band Edge	Test Date	November 18, 2020
Polarize	Horizontal	Test Engineer	Ray Li
Detector	Peak and Average		

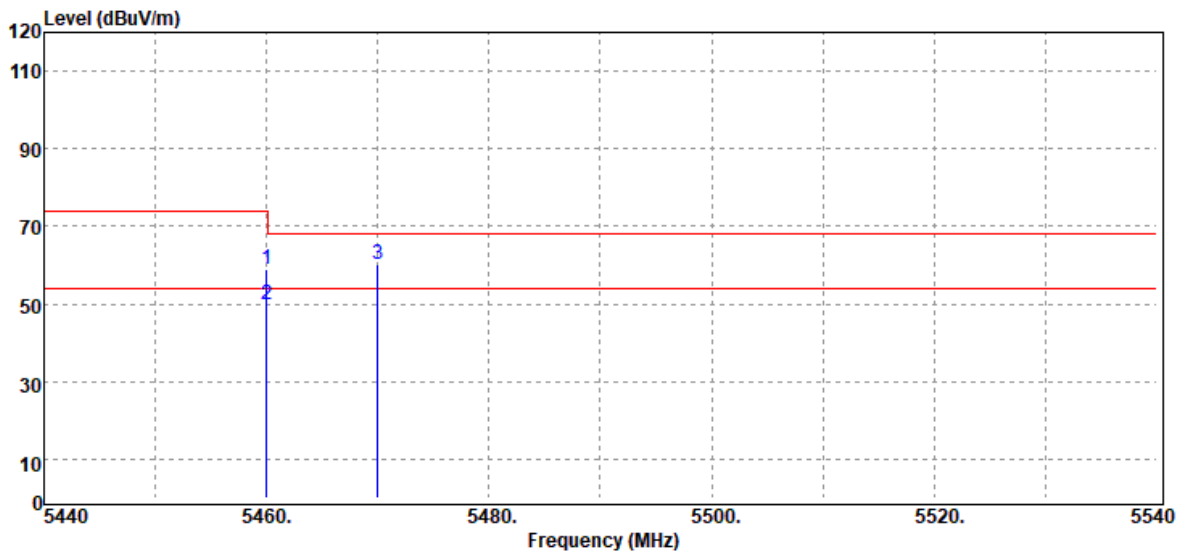

Frequency (MHz)	Detector Mode PK/QP/AV	Spectrum Reading Level dB μ V	Factor dB	Actual FS dB μ V/m	Limit @3m dB μ V/m	Margin dB
5460.00	Peak	68.62	-9.47	59.15	74.00	-14.85
5460.00	Average	59.49	-9.47	50.02	54.00	-3.98
5470.00	Peak	69.47	-9.43	60.04	68.20	-8.16

Test Data for UNII-3

Test Mode	IEEE 802.11a / 5745 MHz	Temp/Hum	22.6(°C)/ 63%RH
Test Item	Band Edge	Test Date	November 13, 2020
Polarize	Vertical	Test Engineer	Ray Li
Detector	Peak		

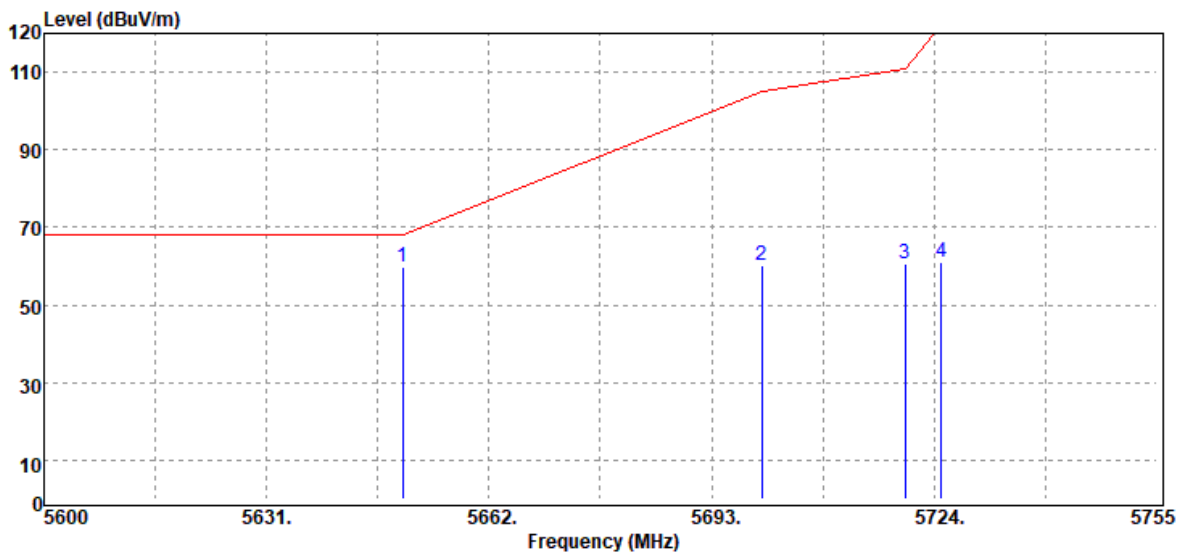

Frequency (MHz)	Detector Mode PK/QP/AV	Spectrum Reading Level dBμV	Factor dB	Actual FS dBμV/m	Limit @3m dBμV/m	Margin dB
5650.00	Peak	68.43	-8.76	59.67	68.20	-8.53
5700.00	Peak	68.80	-8.64	60.16	105.20	-45.04
5720.00	Peak	69.32	-8.58	60.74	110.80	-50.06
5725.00	Peak	69.56	-8.57	60.99	122.20	-61.21

Test Mode	IEEE 802.11a / 5745 MHz	Temp/Hum	22.6(°C)/ 63%RH
Test Item	Band Edge	Test Date	November 13, 2020
Polarize	Horizontal	Test Engineer	Ray Li
Detector	Peak		

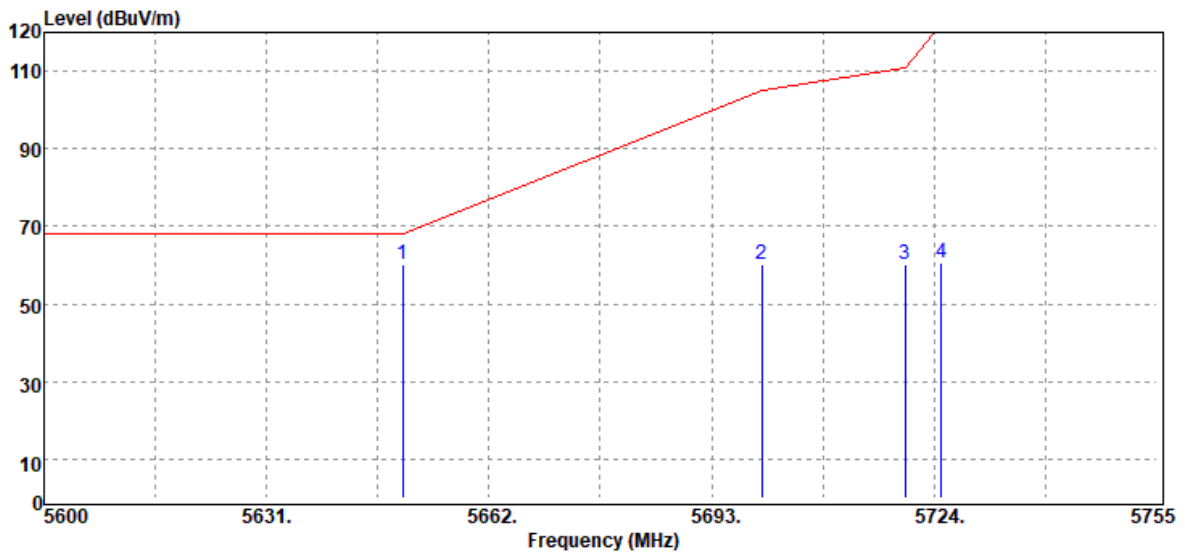

Frequency (MHz)	Detector Mode PK/QP/AV	Spectrum Reading Level dBμV	Factor dB	Actual FS dBμV/m	Limit @3m dBμV/m	Margin dB
5650.00	Peak	68.97	-8.76	60.21	68.20	-7.99
5700.00	Peak	68.93	-8.64	60.29	105.20	-44.91
5720.00	Peak	68.87	-8.58	60.29	110.80	-50.51
5725.00	Peak	69.01	-8.57	60.44	122.20	-61.76

Report No.: T201104D06-RP4

Test Mode	IEEE 802.11a / 5825 MHz	Temp/Hum	22.6(°C)/ 63%RH
Test Item	Band Edge	Test Date	November 13, 2020
Polarize	Vertical	Test Engineer	Ray Li
Detector	Peak		

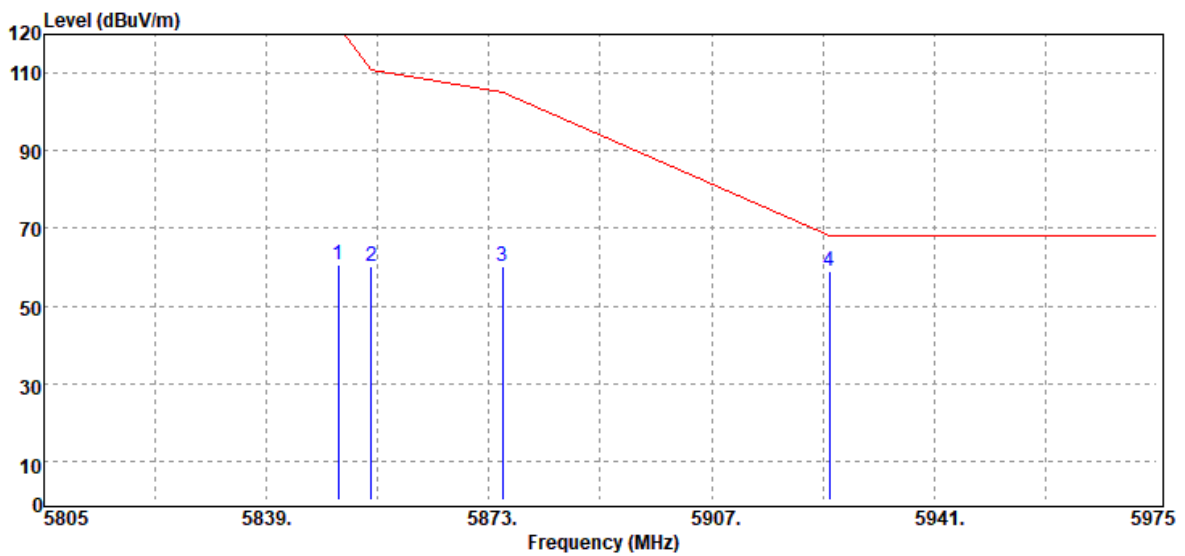

Frequency (MHz)	Detector Mode PK/QP/AV	Spectrum Reading Level dB μ V	Factor dB	Actual FS dB μ V/m	Limit @3m dB μ V/m	Margin dB
5850.00	Peak	69.25	-8.60	60.65	122.20	-61.55
5855.00	Peak	68.82	-8.60	60.22	110.80	-50.58
5875.00	Peak	68.97	-8.59	60.38	105.20	-44.82
5925.00	Peak	67.68	-8.65	59.03	68.20	-9.17

Report No.: T201104D06-RP4

Test Mode	IEEE 802.11a / 5825 MHz	Temp/Hum	22.6(°C)/ 63%RH
Test Item	Band Edge	Test Date	November 13, 2020
Polarize	Horizontal	Test Engineer	Ray Li
Detector	Peak		

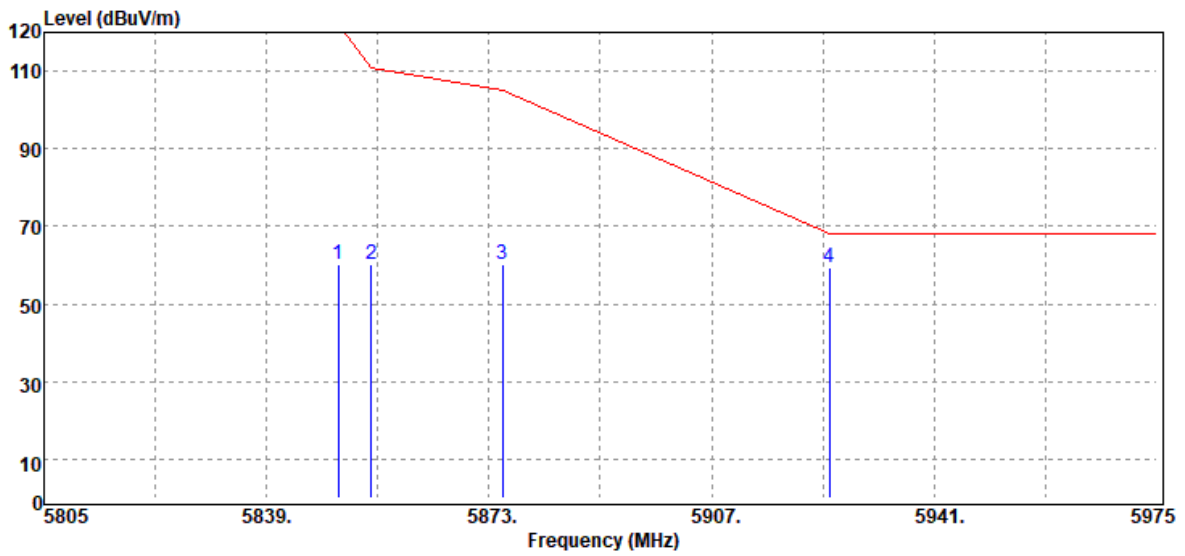

Frequency (MHz)	Detector Mode PK/QP/AV	Spectrum Reading Level dB μ V	Factor dB	Actual FS dB μ V/m	Limit @3m dB μ V/m	Margin dB
5850.00	Peak	68.78	-8.60	60.18	122.20	-62.02
5855.00	Peak	68.88	-8.60	60.28	110.80	-50.52
5875.00	Peak	68.97	-8.59	60.38	105.20	-44.82
5925.00	Peak	68.16	-8.65	59.51	68.20	-8.69

Report No.: T201104D06-RP4

Test Mode	IEEE 802.11n 20 MHz / 5745 MHz	Temp/Hum	22.6(°C)/ 63%RH
Test Item	Band Edge	Test Date	November 13, 2020
Polarize	Vertical	Test Engineer	Ray Li
Detector	Peak		

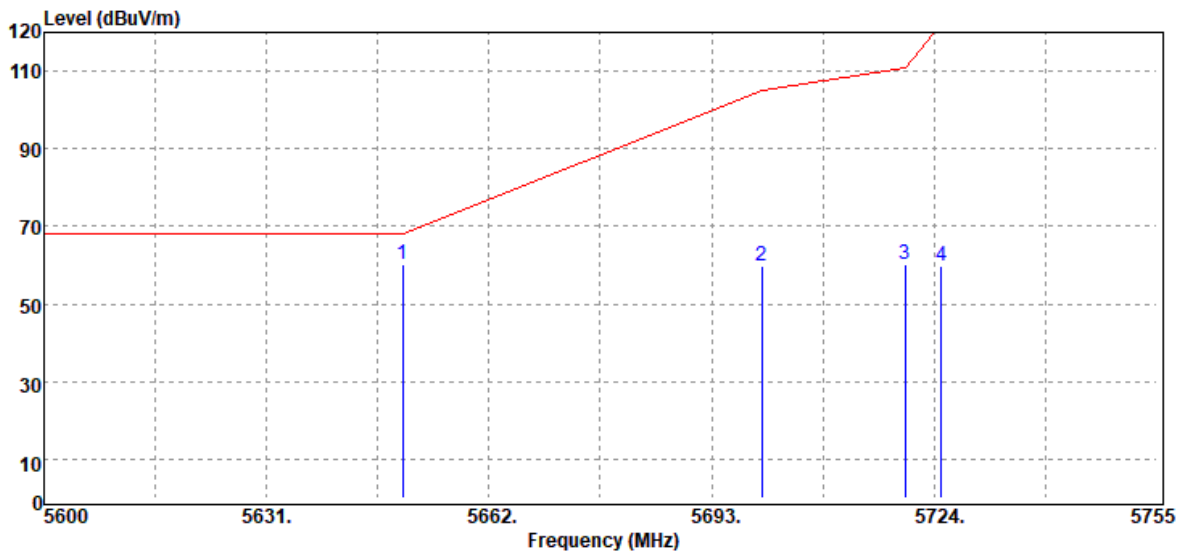

Frequency (MHz)	Detector Mode PK/QP/AV	Spectrum Reading Level dB μ V	Factor dB	Actual FS dB μ V/m	Limit @3m dB μ V/m	Margin dB
5650.00	Peak	69.13	-8.76	60.37	68.20	-7.83
5700.00	Peak	68.59	-8.64	59.95	105.20	-45.25
5720.00	Peak	68.80	-8.58	60.22	110.80	-50.58
5725.00	Peak	68.21	-8.57	59.64	122.20	-62.56

Test Mode	IEEE 802.11n 20 MHz / 5745 MHz	Temp/Hum	22.6(°C)/ 63%RH
Test Item	Band Edge	Test Date	November 13, 2020
Polarize	Horizontal	Test Engineer	Ray Li
Detector	Peak		

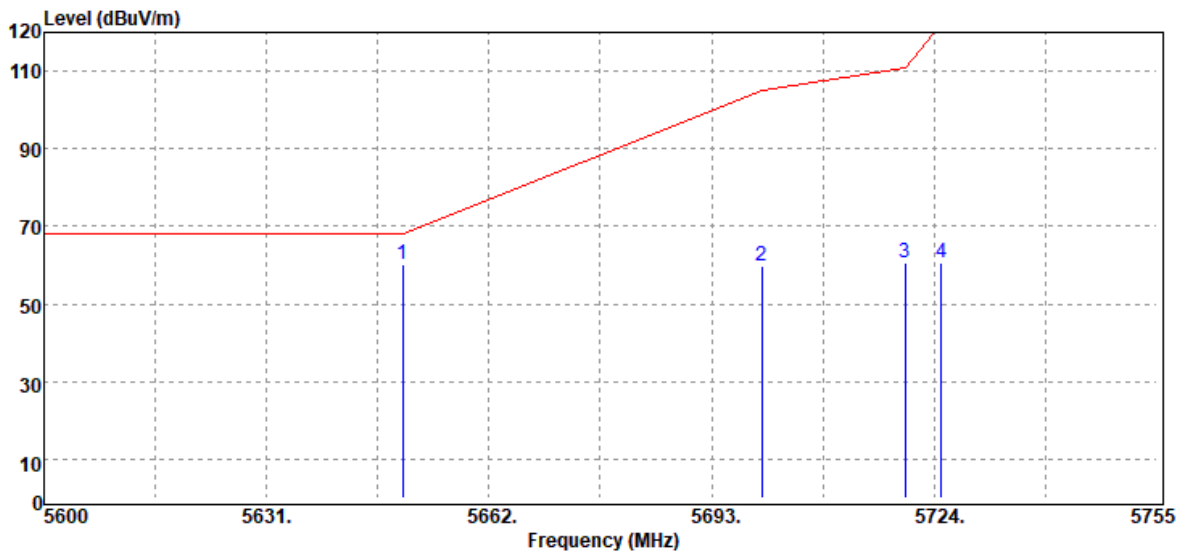

Frequency (MHz)	Detector Mode PK/QP/AV	Spectrum Reading Level dB μ V	Factor dB	Actual FS dB μ V/m	Limit @3m dB μ V/m	Margin dB
5650.00	Peak	68.96	-8.76	60.20	68.20	-8.00
5700.00	Peak	68.40	-8.64	59.76	105.20	-45.44
5720.00	Peak	69.10	-8.58	60.52	110.80	-50.28
5725.00	Peak	69.27	-8.57	60.70	122.20	-61.50

Report No.: T201104D06-RP4

Test Mode	IEEE 802.11n 20 MHz / 5825 MHz	Temp/Hum	22.6(°C)/ 63%RH
Test Item	Band Edge	Test Date	November 13, 2020
Polarize	Vertical	Test Engineer	Ray Li
Detector	Peak		

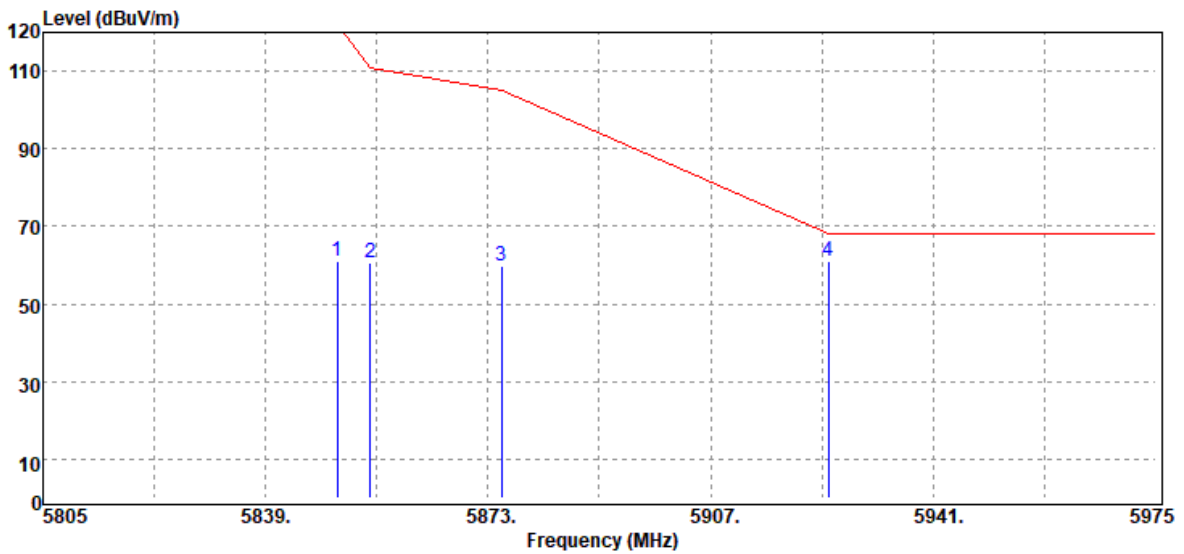

Frequency (MHz)	Detector Mode PK/QP/AV	Spectrum Reading Level dB μ V	Factor dB	Actual FS dB μ V/m	Limit @3m dB μ V/m	Margin dB
5850.00	Peak	69.74	-8.60	61.14	122.20	-61.06
5855.00	Peak	69.03	-8.60	60.43	110.80	-50.37
5875.00	Peak	68.37	-8.59	59.78	105.20	-45.42
5925.00	Peak	69.62	-8.65	60.97	68.20	-7.23

Report No.: T201104D06-RP4

Test Mode	IEEE 802.11n 20 MHz / 5825 MHz	Temp/Hum	22.6(°C)/ 63%RH
Test Item	Band Edge	Test Date	November 13, 2020
Polarize	Horizontal	Test Engineer	Ray Li
Detector	Peak		

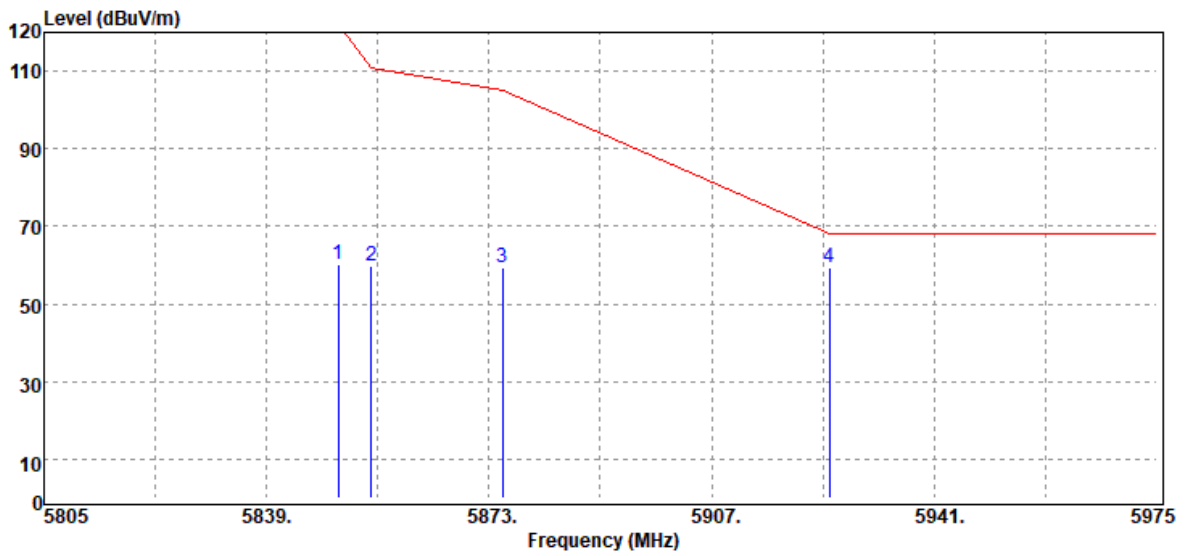

Frequency (MHz)	Detector Mode PK/QP/AV	Spectrum Reading Level dB μ V	Factor dB	Actual FS dB μ V/m	Limit @3m dB μ V/m	Margin dB
5850.00	Peak	68.68	-8.60	60.08	122.20	-62.12
5855.00	Peak	68.43	-8.60	59.83	110.80	-50.97
5875.00	Peak	67.95	-8.59	59.36	105.20	-45.84
5925.00	Peak	68.12	-8.65	59.47	68.20	-8.73

Report No.: T201104D06-RP4

Test Mode	IEEE 802.11n 40 MHz/ 5755 MHz	Temp/Hum	22.6(°C)/ 63%RH
Test Item	Band Edge	Test Date	November 13, 2020
Polarize	Vertical	Test Engineer	Ray Li
Detector	Peak		

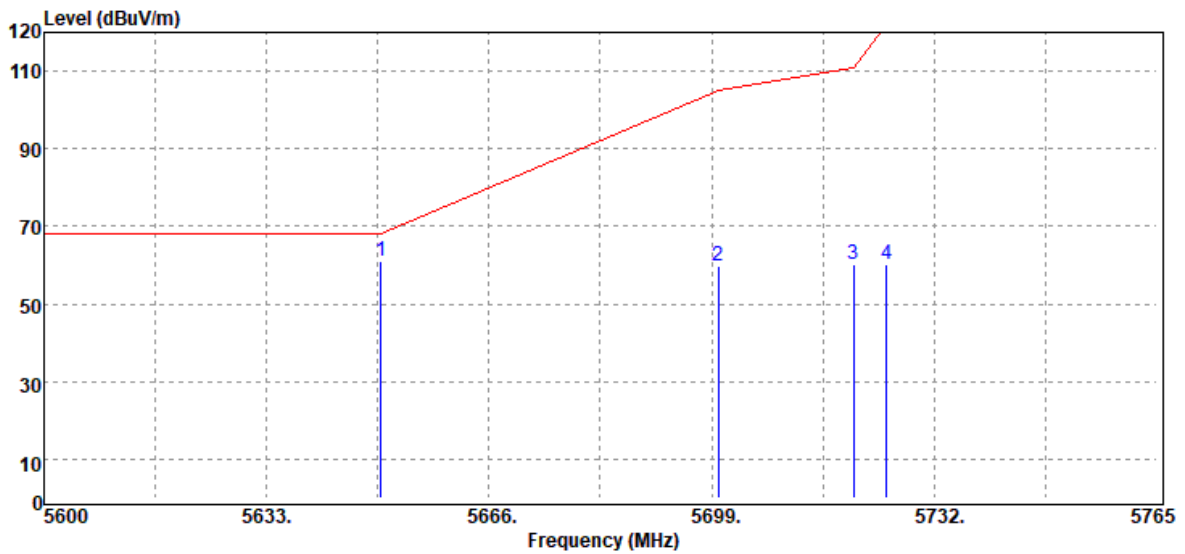

Frequency (MHz)	Detector Mode PK/QP/AV	Spectrum Reading Level dB μ V	Factor dB	Actual FS dB μ V/m	Limit @3m dB μ V/m	Margin dB
5650.00	Peak	69.71	-8.76	60.95	68.20	-7.25
5700.00	Peak	68.44	-8.64	59.80	105.20	-45.40
5720.00	Peak	68.96	-8.58	60.38	110.80	-50.42
5725.00	Peak	68.93	-8.57	60.36	122.20	-61.84

Test Mode	IEEE 802.11n 40 MHz/ 5755 MHz	Temp/Hum	22.6(°C)/ 63%RH
Test Item	Band Edge	Test Date	November 13, 2020
Polarize	Horizontal	Test Engineer	Ray Li
Detector	Peak		

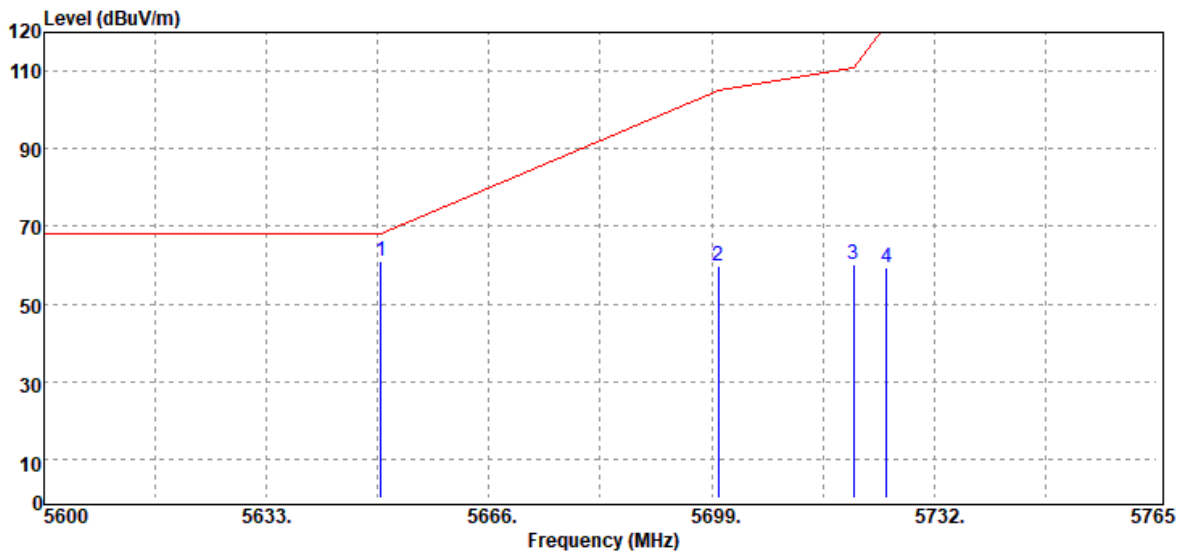

Frequency (MHz)	Detector Mode PK/QP/AV	Spectrum Reading Level dB μ V	Factor dB	Actual FS dB μ V/m	Limit @3m dB μ V/m	Margin dB
5650.00	Peak	69.63	-8.76	60.87	68.20	-7.33
5700.00	Peak	68.43	-8.64	59.79	105.20	-45.41
5720.00	Peak	68.69	-8.58	60.11	110.80	-50.69
5725.00	Peak	67.97	-8.57	59.40	122.20	-62.80

Report No.: T201104D06-RP4

Test Mode	IEEE 802.11n 40 MHz/ 5795 MHz	Temp/Hum	22.6(°C)/ 65%RH
Test Item	Band Edge	Test Date	November 18, 2020
Polarize	Vertical	Test Engineer	Ray Li
Detector	Peak		

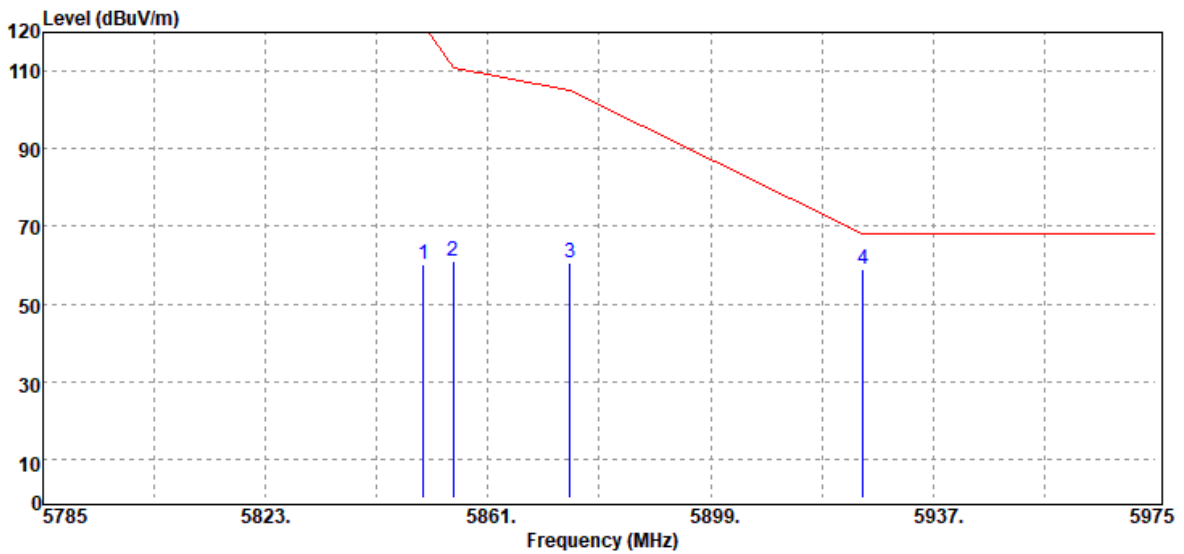

Frequency (MHz)	Detector Mode PK/QP/AV	Spectrum Reading Level dB μ V	Factor dB	Actual FS dB μ V/m	Limit @3m dB μ V/m	Margin dB
5850.00	Peak	68.84	-8.60	60.24	122.20	-61.96
5855.00	Peak	69.49	-8.60	60.89	110.80	-49.91
5875.00	Peak	69.08	-8.59	60.49	105.20	-44.71
5925.00	Peak	67.74	-8.65	59.09	68.20	-9.11

Report No.: T201104D06-RP4

Test Mode	IEEE 802.11n 40 MHz/ 5795 MHz	Temp/Hum	22.6(°C)/ 65%RH
Test Item	Band Edge	Test Date	November 18, 2020
Polarize	Horizontal	Test Engineer	Ray Li
Detector	Peak		

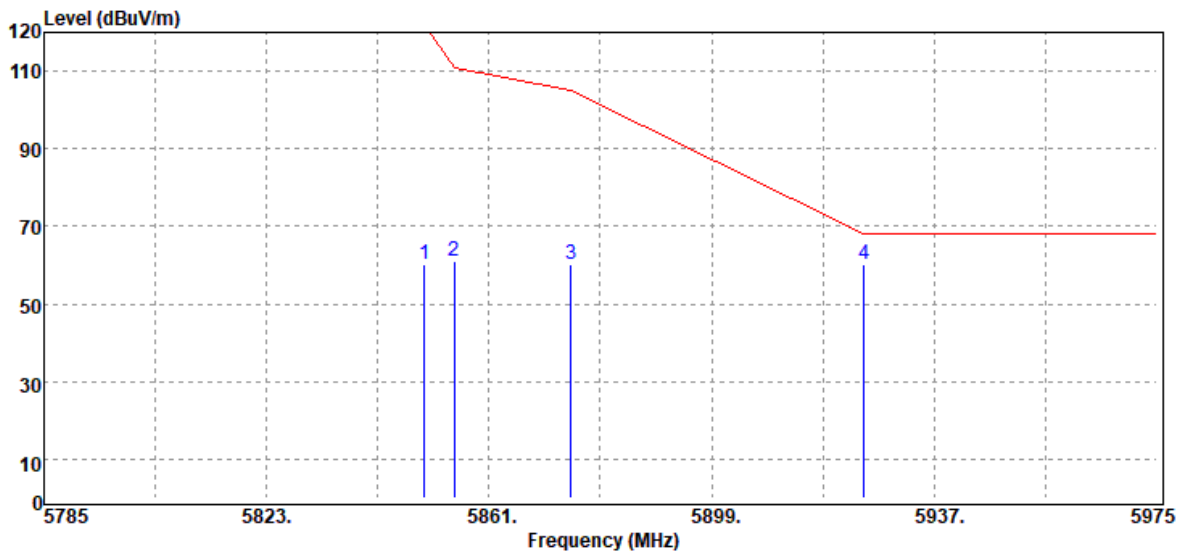

Frequency (MHz)	Detector Mode PK/QP/AV	Spectrum Reading Level dB μ V	Factor dB	Actual FS dB μ V/m	Limit @3m dB μ V/m	Margin dB
5850.00	Peak	68.70	-8.60	60.10	122.20	-62.10
5855.00	Peak	69.56	-8.60	60.96	110.80	-49.84
5875.00	Peak	68.92	-8.59	60.33	105.20	-44.87
5925.00	Peak	68.77	-8.65	60.12	68.20	-8.08

Report No.: T201104D06-RP4

Test Mode	IEEE 802.11ac VHT80 / 5775 MHz	Temp/Hum	22.6(°C)/ 65%RH
Test Item	Band Edge	Test Date	November 18, 2020
Polarize	Vertical	Test Engineer	Ray Li
Detector	Peak		

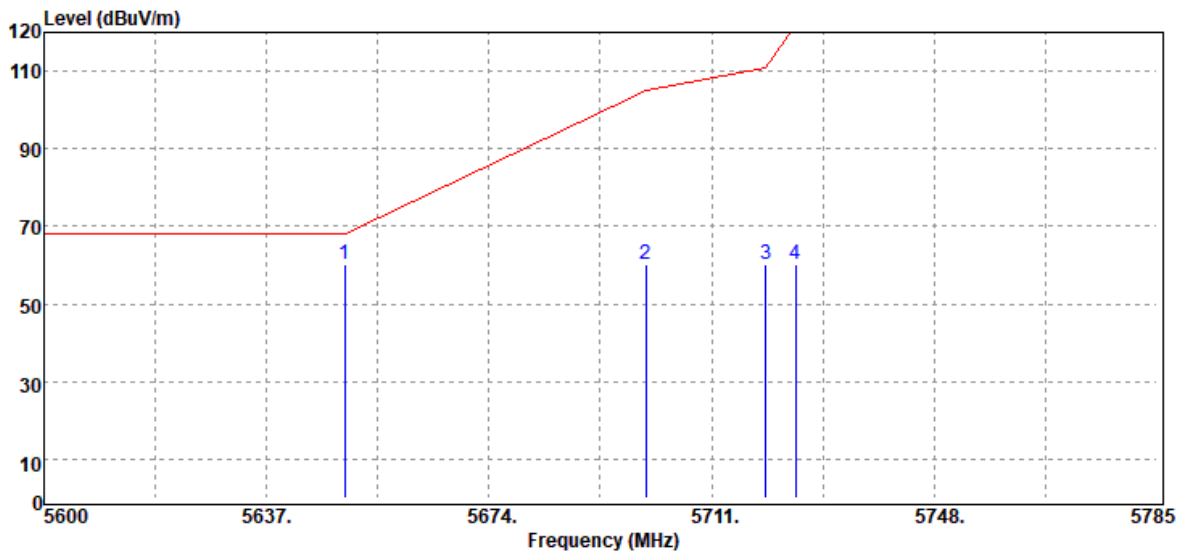

Frequency (MHz)	Detector Mode PK/QP/AV	Spectrum Reading Level dB μ V	Factor dB	Actual FS dB μ V/m	Limit @3m dB μ V/m	Margin dB
5650.00	Peak	68.95	-8.76	60.19	68.20	-8.01
5700.00	Peak	68.82	-8.64	60.18	105.20	-45.02
5720.00	Peak	68.99	-8.58	60.41	110.80	-50.39
5725.00	Peak	68.60	-8.57	60.03	122.20	-62.17

Test Mode	IEEE 802.11ac VHT80 / 5775 MHz	Temp/Hum	22.6(°C)/ 65%RH
Test Item	Band Edge	Test Date	November 18, 2020
Polarize	Horizontal	Test Engineer	Ray Li
Detector	Peak		

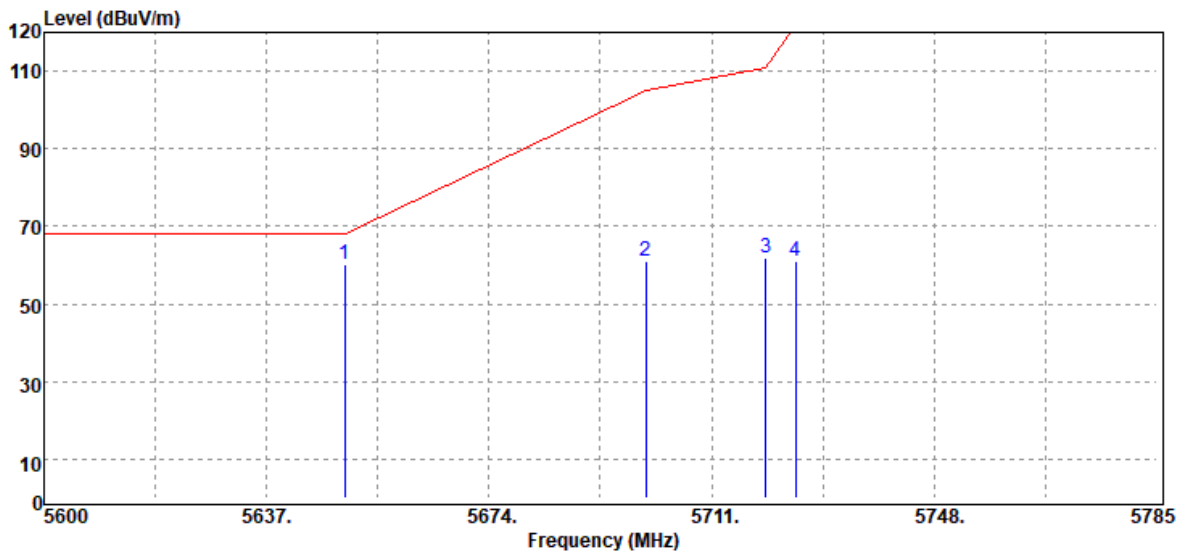

Frequency (MHz)	Detector Mode PK/QP/AV	Spectrum Reading Level dB μ V	Factor dB	Actual FS dB μ V/m	Limit @3m dB μ V/m	Margin dB
5650.00	Peak	68.98	-8.76	60.22	68.20	-7.98
5700.00	Peak	69.49	-8.64	60.85	105.20	-44.35
5720.00	Peak	70.46	-8.58	61.88	110.80	-48.92
5725.00	Peak	69.62	-8.57	61.05	122.20	-61.15

Report No.: T201104D06-RP4

Test Mode	IEEE 802.11ac VHT80 / 5775 MHz	Temp/Hum	22.6(°C)/ 65%RH
Test Item	Band Edge	Test Date	November 18, 2020
Polarize	Vertical	Test Engineer	Ray Li
Detector	Peak		

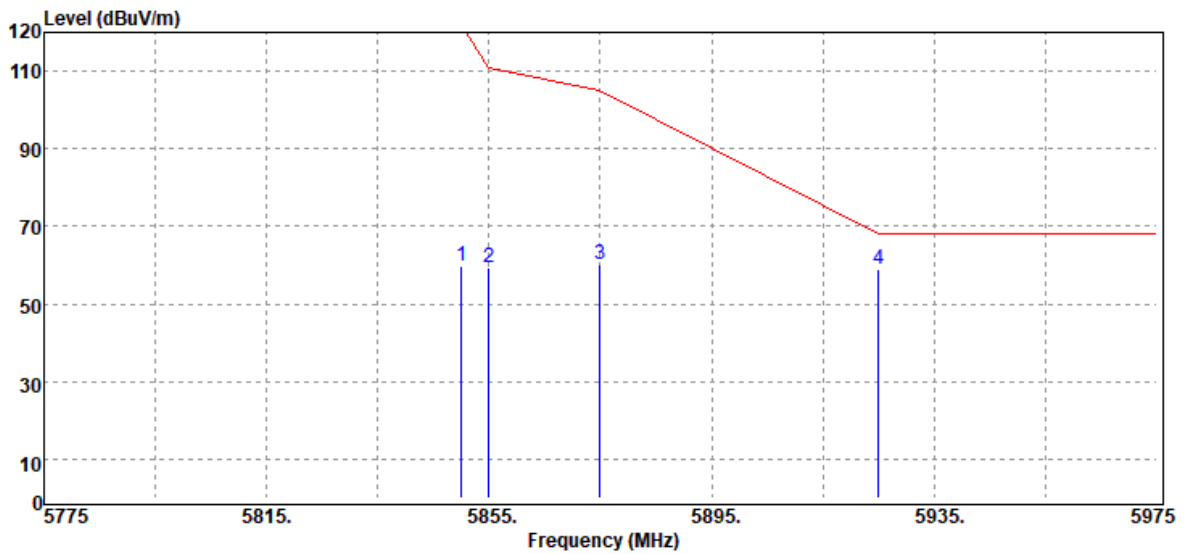

Frequency (MHz)	Detector Mode PK/QP/AV	Spectrum Reading Level dBμV	Factor dB	Actual FS dBμV/m	Limit @3m dBμV/m	Margin dB
5850.00	Peak	68.58	-8.60	59.98	122.20	-62.22
5855.00	Peak	67.93	-8.60	59.33	110.80	-51.47
5875.00	Peak	68.67	-8.59	60.08	105.20	-45.12
5925.00	Peak	67.53	-8.65	58.88	68.20	-9.32

Report No.: T201104D06-RP4

Test Mode	IEEE 802.11ac VHT80 / 5775 MHz	Temp/Hum	22.6(°C)/ 65%RH
Test Item	Band Edge	Test Date	November 18, 2020
Polarize	Horizontal	Test Engineer	Ray Li
Detector	Peak		

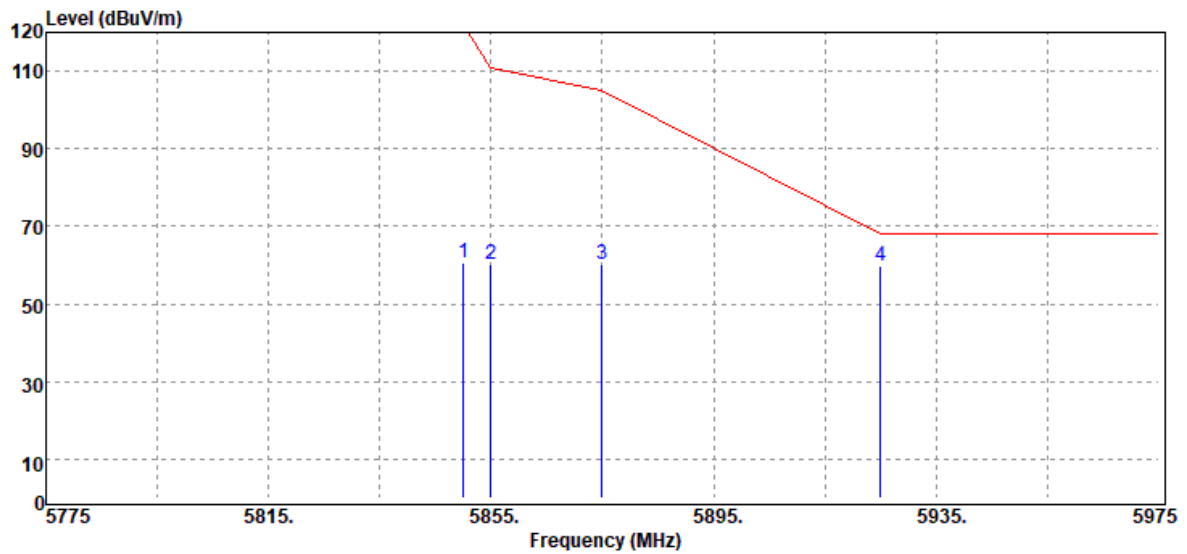

Frequency (MHz)	Detector Mode PK/QP/AV	Spectrum Reading Level dB μ V	Factor dB	Actual FS dB μ V/m	Limit @3m dB μ V/m	Margin dB
5850.00	Peak	69.42	-8.60	60.82	122.20	-61.38
5855.00	Peak	68.76	-8.60	60.16	110.80	-50.64
5875.00	Peak	68.85	-8.59	60.26	105.20	-44.94
5925.00	Peak	68.26	-8.65	59.61	68.20	-8.59

Report No.: T201104D06-RP4

Below 1G Test Data

Test Mode	Mode 1	Temp/Hum	22.6(°C)/ 59%RH
Test Item	30MHz-1GHz	Test Date	November 11, 2020
Polarize	Vertical	Test Engineer	Jerry Chang
Detector	Peak		

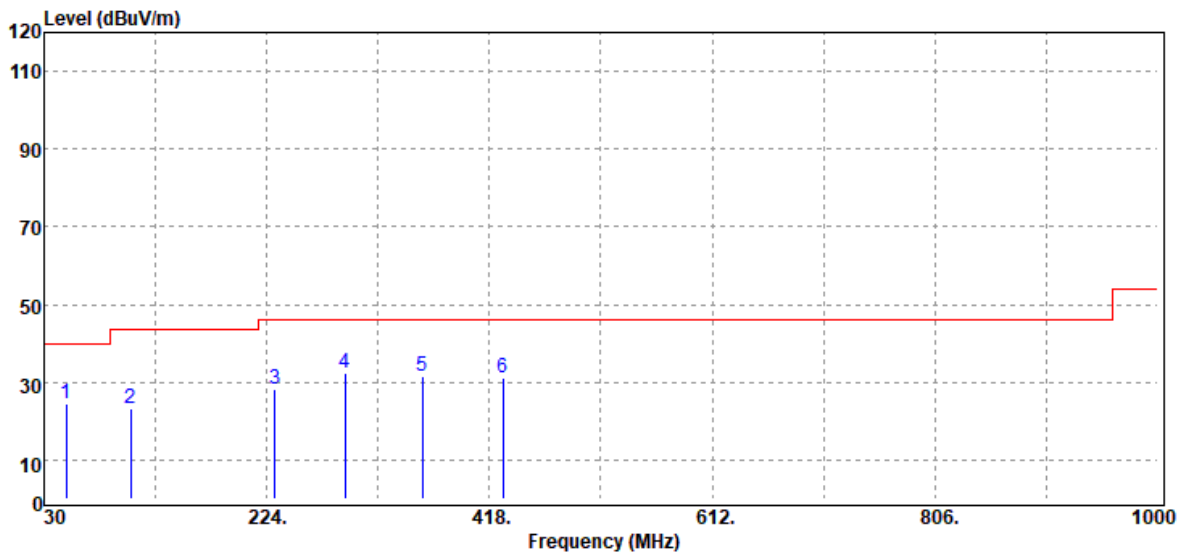

Freq. MHz	Detector Mode PK/QP/AV	Spectrum Reading Level dBµV	Factor dB	Actual FS dBµV/m	Limit @3m dBµV/m	Margin dB
49.40	Peak	-490.49	515.14	24.65	40.00	-15.35
105.66	Peak	-495.77	519.06	23.29	43.50	-20.21
230.79	Peak	-490.91	518.98	28.07	46.00	-17.93
291.90	Peak	-488.95	521.39	32.44	46.00	-13.56
359.80	Peak	-491.68	523.23	31.55	46.00	-14.45
429.64	Peak	-494.08	525.08	31.00	46.00	-15.00

Note: 1. No emission found between lowest internal used/generated frequency to 30MHz(9KHz~30MHz)
2. For below 1GHz, the EUT peak value was under average limit, therefore the Average value compliance with the average limit.

Report No.: T201104D06-RP4

Test Mode	Mode 1	Temp/Hum	22.6(°C)/ 59%RH
Test Item	30MHz-1GHz	Test Date	November 11, 2020
Polarize	Horizontal	Test Engineer	Jerry Chang
Detector	Peak		

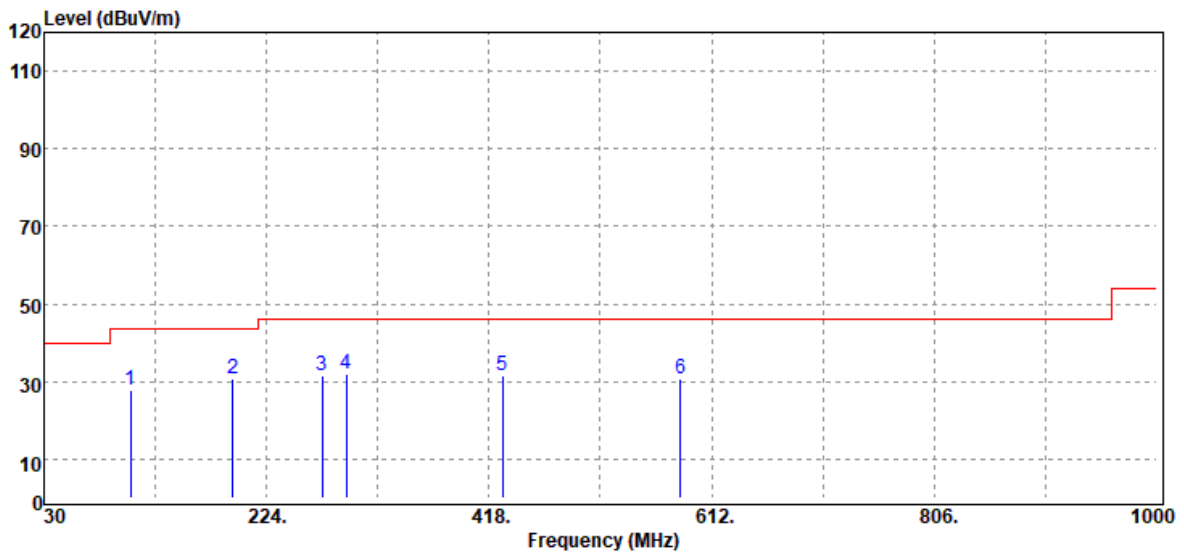

Freq. MHz	Detector Mode PK/QP/AV	Spectrum Reading Level dB μ V	Factor dB	Actual FS dB μ V/m	Limit @3m dB μ V/m	Margin dB
105.66	Peak	-491.40	519.06	27.66	43.50	-15.84
194.90	Peak	-489.24	519.99	30.75	43.50	-12.75
272.50	Peak	-489.59	521.29	31.70	46.00	-14.30
293.84	Peak	-489.62	521.40	31.78	46.00	-14.22
429.64	Peak	-493.48	525.08	31.60	46.00	-14.40
584.84	Peak	-496.73	527.54	30.81	46.00	-15.19

Note: 1. No emission found between lowest internal used/generated frequency to 30MHz(9KHz~30MHz)
2. For below 1GHz, the EUT peak value was under average limit, therefore the Average value compliance with the average limit.

Report No.: T201104D06-RP4

Above 1G

Test Data for UNII-1

Test Mode	IEEE 802.11a / 5180MHZ	Temp/Hum	22.6(°C)/ 59%RH
Test Item	Harmonic	Test Date	November 11, 2020
Polarize	Vertical	Test Engineer	Ray Li
Detector	Peak		

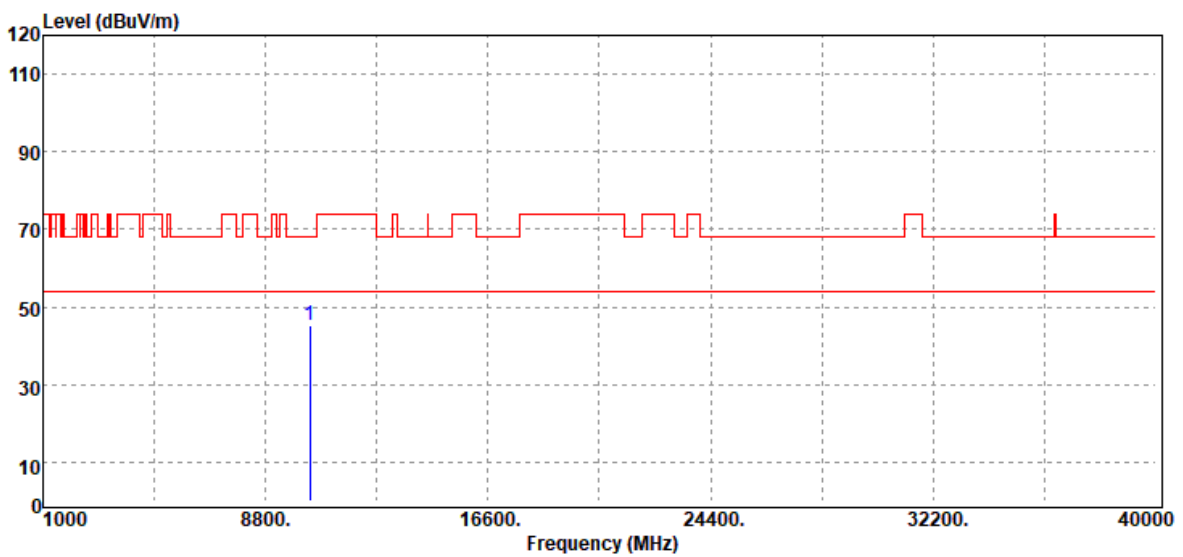

Freq. MHz	Detector Mode PK/QP/AV	Spectrum Reading Level dB μ V	Factor dB	Actual FS dB μ V/m	Limit @3m dB μ V/m	Margin dB
10360.00	Peak	43.04	2.13	45.17	68.20	-23.03
N/A						

Remark:

1. Measuring frequencies from 1 GHz to the 10th harmonic of highest fundamental frequency.
2. For above 1GHz, the EUT peak value was under average limit, therefore the Average value compliance with the average limit

Report No.: T201104D06-RP4

Test Mode	IEEE 802.11a / 5180MHZ	Temp/Hum	22.6(°C)/ 59%RH
Test Item	Harmonic	Test Date	November 11, 2020
Polarize	Horizontal	Test Engineer	Ray Li
Detector	Peak		

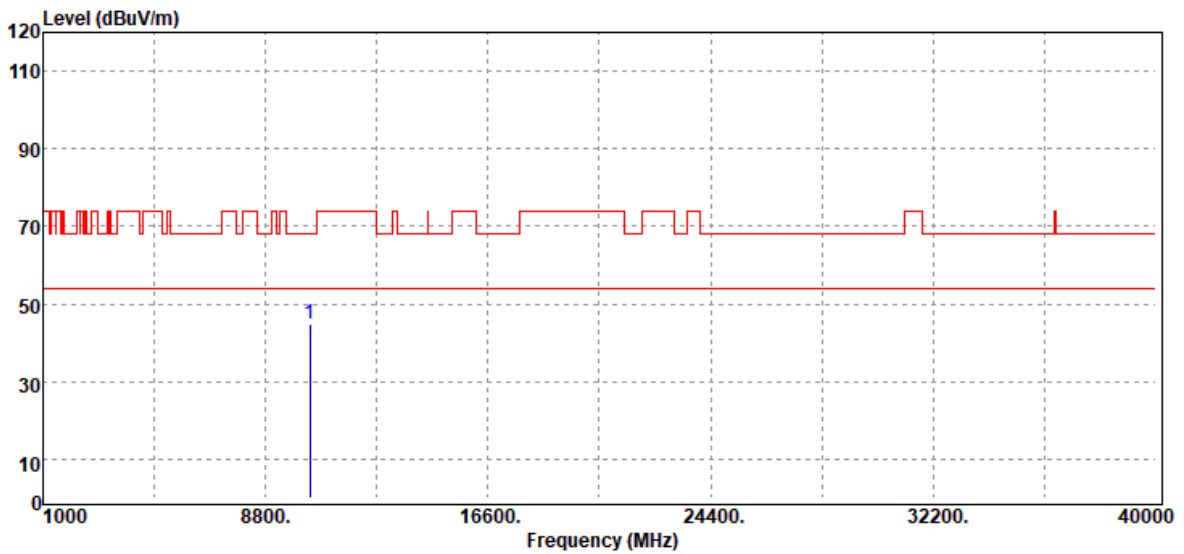

Freq. MHz	Detector Mode PK/QP/AV	Spectrum Reading Level dB μ V	Factor dB	Actual FS dB μ V/m	Limit @3m dB μ V/m	Margin dB
10360.00	Peak	42.76	2.13	44.89	68.20	-23.31
N/A						

Remark:

1. Measuring frequencies from 1 GHz to the 10th harmonic of highest fundamental frequency.
2. For above 1GHz, the EUT peak value was under average limit, therefore the Average value compliance with the average limit

Report No.: T201104D06-RP4

Test Mode	IEEE 802.11a / 5220 MHz	Temp/Hum	22.6(°C)/ 59%RH
Test Item	Harmonics	Test Date	November 11, 2020
Polarize	Vertical	Test Engineer	Ray Li
Detector	Peak		

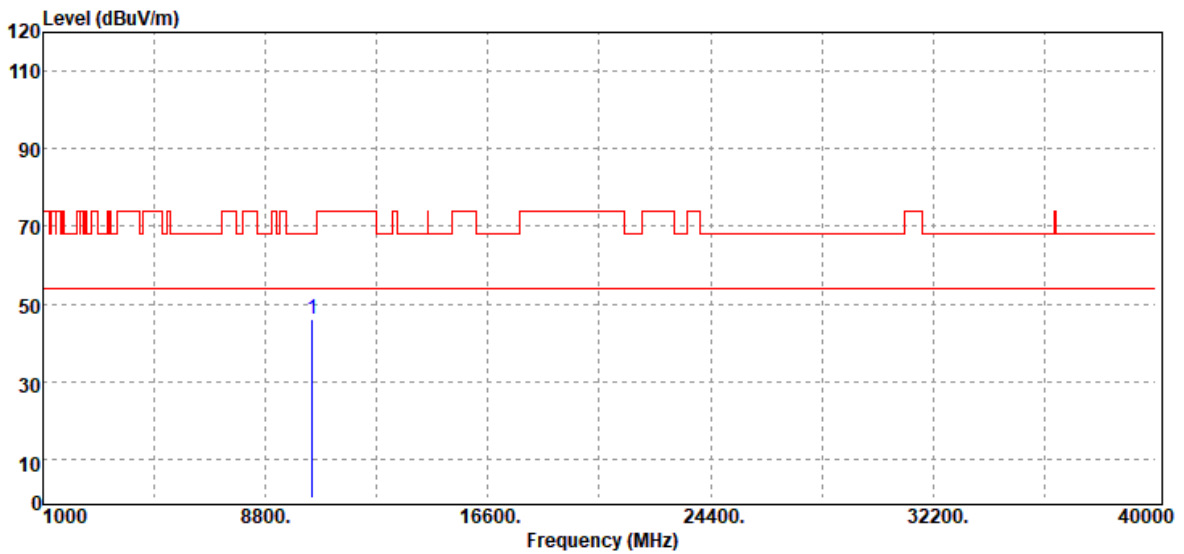

Freq. MHz	Detector Mode PK/QP/AV	Spectrum Reading Level dB μ V	Factor dB	Actual FS dB μ V/m	Limit @3m dB μ V/m	Margin dB
10440.00	Peak	44.12	2.14	46.26	68.20	-21.94
N/A						

Remark:

1. Measuring frequencies from 1 GHz to the 10th harmonic of highest fundamental frequency.
2. For above 1GHz, the EUT peak value was under average limit, therefore the Average value compliance with the average limit

Report No.: T201104D06-RP4

Test Mode	IEEE 802.11a / 5220 MHz	Temp/Hum	22.6(°C)/ 59%RH
Test Item	Harmonic	Test Date	November 11, 2020
Polarize	Horizontal	Test Engineer	Ray Li
Detector	Peak		

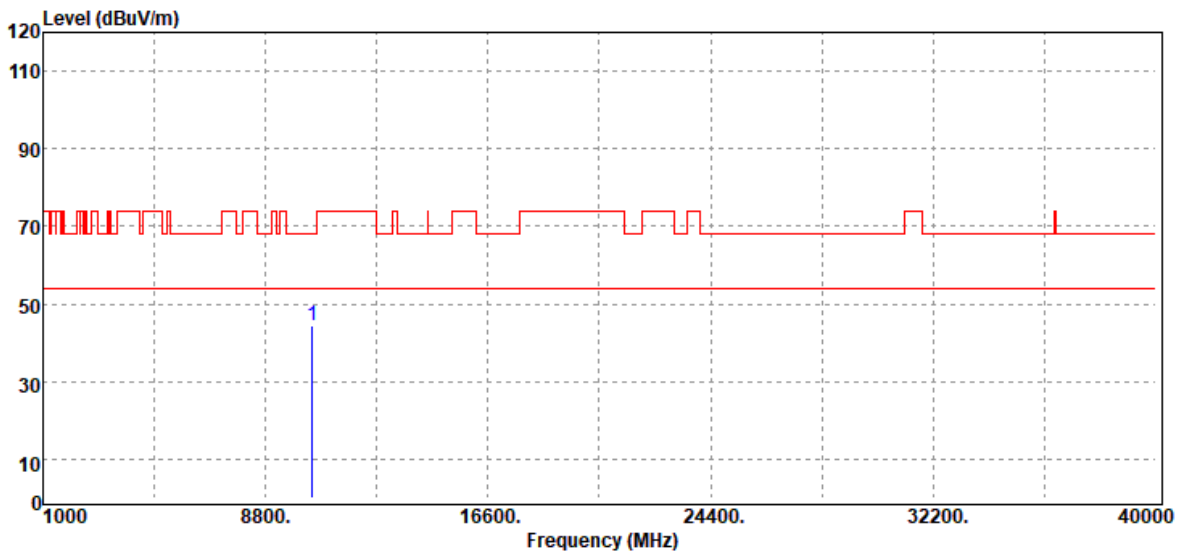

Freq. MHz	Detector Mode PK/QP/AV	Spectrum Reading Level dB μ V	Factor dB	Actual FS dB μ V/m	Limit @3m dB μ V/m	Margin dB
10440.00	Peak	42.20	2.14	44.34	68.20	-23.86
N/A						

Remark:

1. Measuring frequencies from 1 GHz to the 10th harmonic of highest fundamental frequency.
2. For above 1GHz, the EUT peak value was under average limit, therefore the Average value compliance with the average limit

Report No.: T201104D06-RP4

Test Mode	IEEE 802.11a / 5240MHZ	Temp/Hum	22.6(°C)/ 59%RH
Test Item	Harmonic	Test Date	November 11, 2020
Polarize	Vertical	Test Engineer	Ray Li
Detector	Peak		

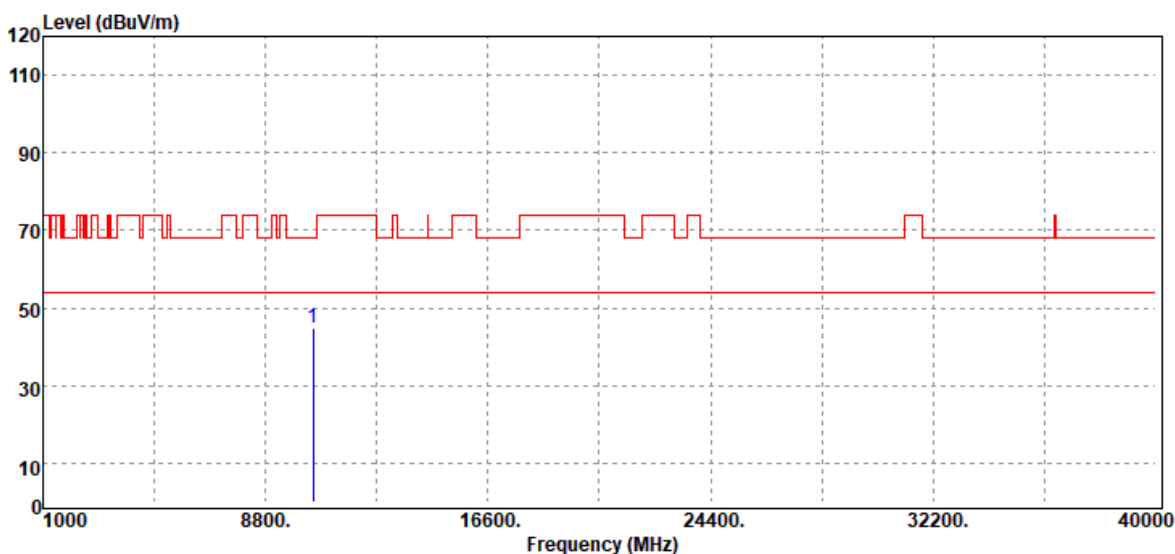

Freq. MHz	Detector Mode PK/QP/AV	Spectrum Reading Level dB μ V	Factor dB	Actual FS dB μ V/m	Limit @3m dB μ V/m	Margin dB
10480.00	Peak	42.54	2.11	44.65	68.20	-23.55
N/A						

Remark:

1. Measuring frequencies from 1 GHz to the 10th harmonic of highest fundamental frequency.
2. For above 1GHz, the EUT peak value was under average limit, therefore the Average value compliance with the average limit

Report No.: T201104D06-RP4

Test Mode	IEEE 802.11a / 5240MHZ	Temp/Hum	22.6(°C)/ 59%RH
Test Item	Harmonic	Test Date	November 11, 2020
Polarize	Horizontal	Test Engineer	Ray Li
Detector	Peak		

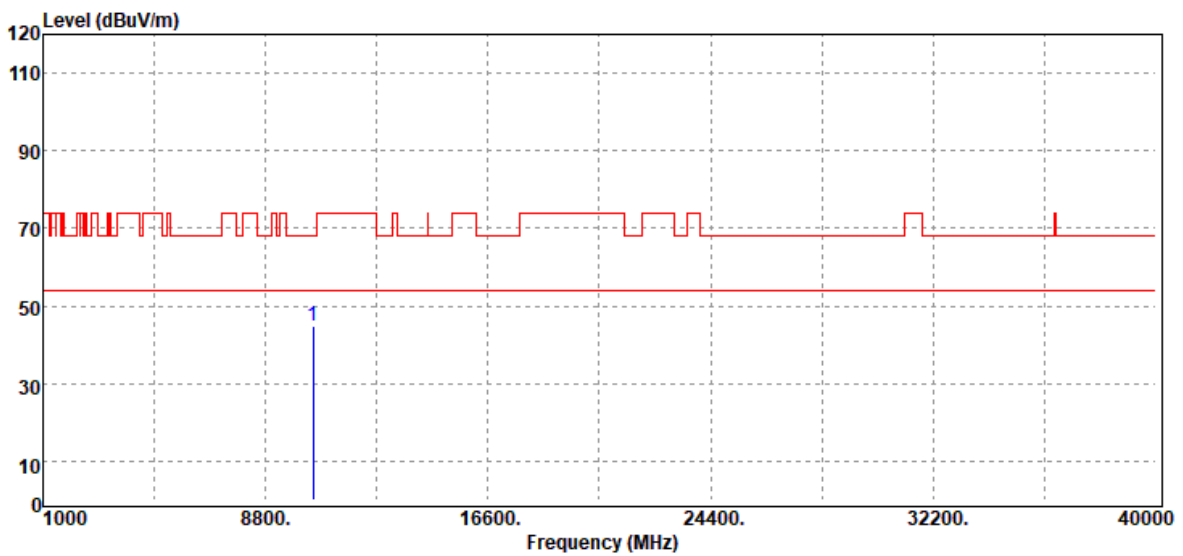

Freq. MHz	Detector Mode PK/QP/AV	Spectrum Reading Level dBµV	Factor dB	Actual FS dBµV/m	Limit @3m dBµV/m	Margin dB
10480.00	Peak	42.66	2.11	44.77	68.20	-23.43
N/A						

Remark:

1. Measuring frequencies from 1 GHz to the 10th harmonic of highest fundamental frequency.
2. For above 1GHz, the EUT peak value was under average limit, therefore the Average value compliance with the average limit

Report No.: T201104D06-RP4

Test Mode	IEEE 802.11n 20 MHz / 5180MHz	Temp/Hum	22.4(°C)/ 67%RH
Test Item	Harmonic	Test Date	November 19, 2020
Polarize	Vertical	Test Engineer	Ray Li
Detector	Peak		

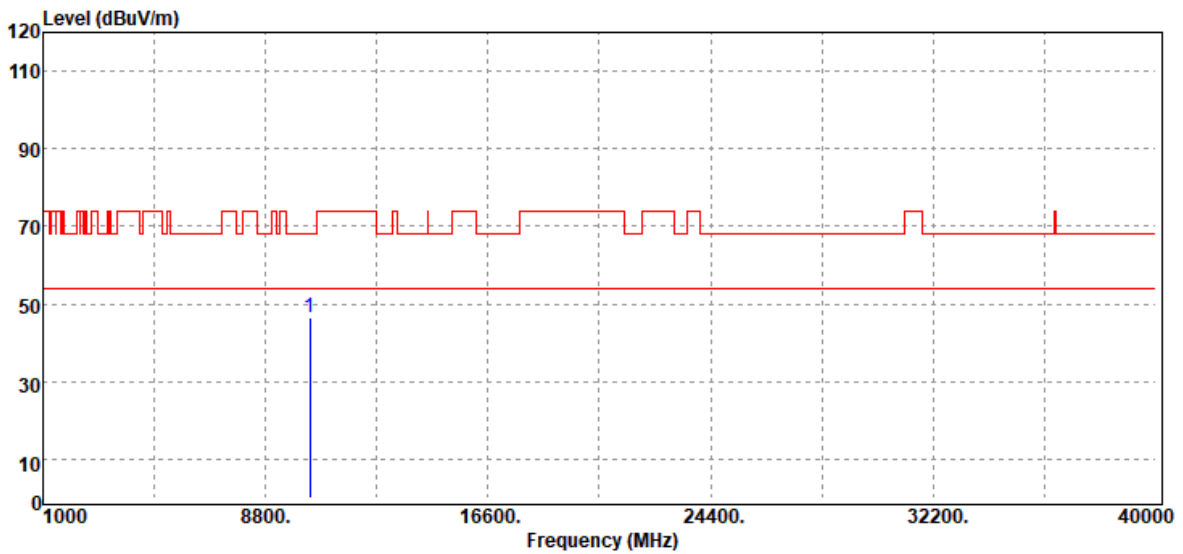

Freq. MHz	Detector Mode PK/QP/AV	Spectrum Reading Level dB μ V	Factor dB	Actual FS dB μ V/m	Limit @3m dB μ V/m	Margin dB
10360.00	Peak	44.54	2.13	46.67	68.20	-21.53
N/A						

Remark:

1. Measuring frequencies from 1 GHz to the 10th harmonic of highest fundamental frequency.
2. For above 1GHz, the EUT peak value was under average limit, therefore the Average value compliance with the average limit

Report No.: T201104D06-RP4

Test Mode	IEEE 802.11n 20 MHz/ 5180MHZ	Temp/Hum	22.4(°C)/ 67%RH
Test Item	Harmonic	Test Date	November 19, 2020
Polarize	Horizontal	Test Engineer	Ray Li
Detector	Peak		

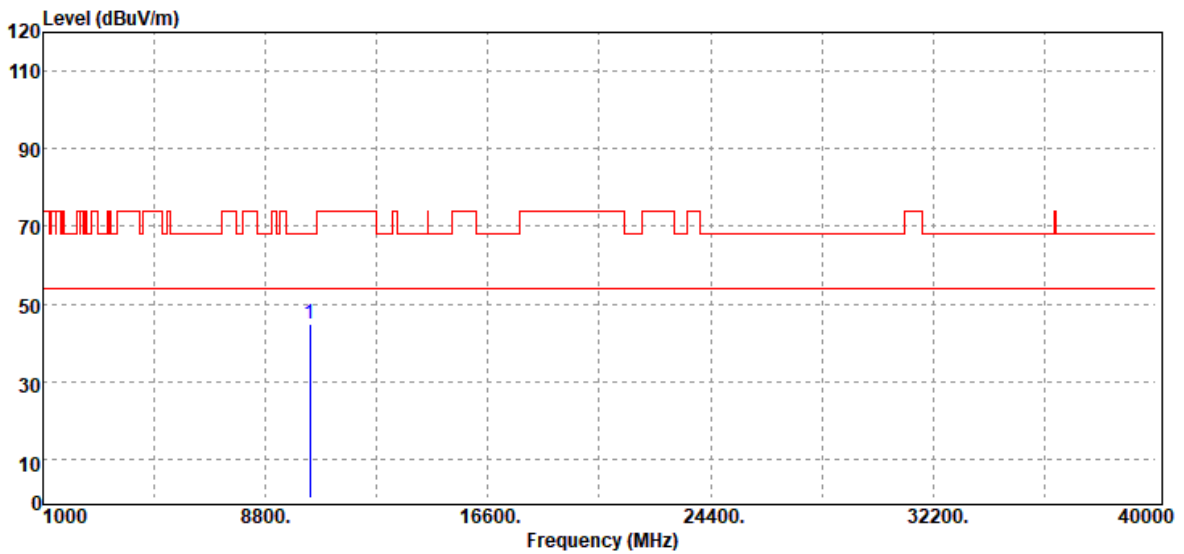

Freq. MHz	Detector Mode PK/QP/AV	Spectrum Reading Level dB μ V	Factor dB	Actual FS dB μ V/m	Limit @3m dB μ V/m	Margin dB
10360.00	Peak	42.86	2.13	44.99	68.20	-23.21
N/A						

Remark:

1. Measuring frequencies from 1 GHz to the 10th harmonic of highest fundamental frequency.
2. For above 1GHz, the EUT peak value was under average limit, therefore the Average value compliance with the average limit

Report No.: T201104D06-RP4

Test Mode	IEEE 802.11n 20 MHz / 5220MHZ	Temp/Hum	22.4(°C)/ 67%RH
Test Item	Harmonic	Test Date	November 19, 2020
Polarize	Vertical	Test Engineer	Ray Li
Detector	Peak		

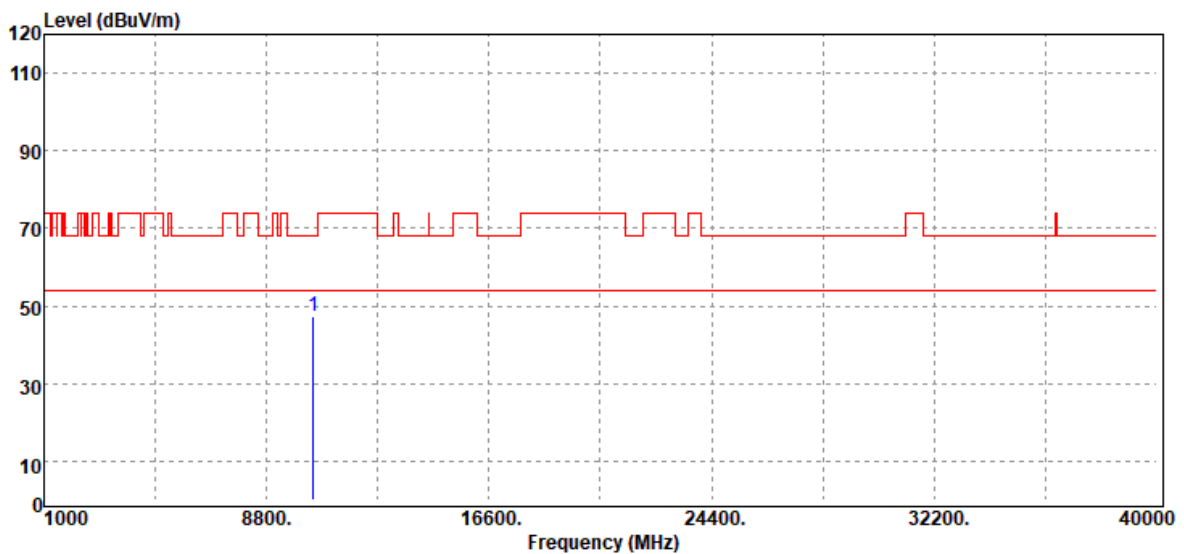

Freq. MHz	Detector Mode PK/QP/AV	Spectrum Reading Level dBμV	Factor dB	Actual FS dBμV/m	Limit @3m dBμV/m	Margin dB
10440.00	Peak	45.24	2.14	47.38	68.20	-20.82
N/A						

Remark:

1. Measuring frequencies from 1 GHz to the 10th harmonic of highest fundamental frequency.
2. For above 1GHz, the EUT peak value was under average limit, therefore the Average value compliance with the average limit

Report No.: T201104D06-RP4

Test Mode	IEEE 802.11n 20 MHz / 5220MHz	Temp/Hum	22.4(°C)/ 67%RH
Test Item	Harmonic	Test Date	November 19, 2020
Polarize	Horizontal	Test Engineer	Ray Li
Detector	Peak		

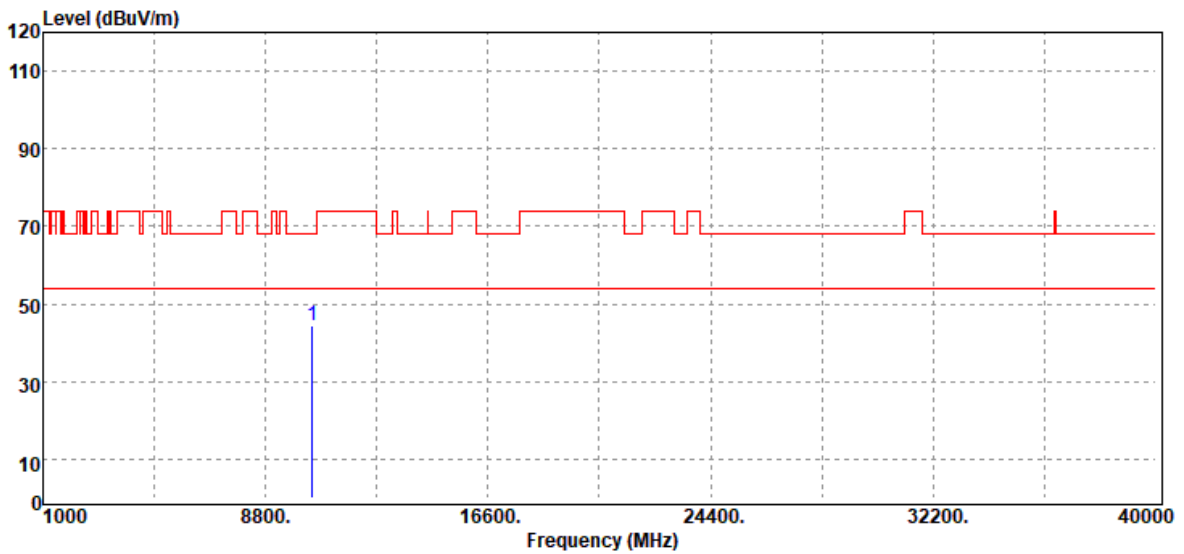

Freq. MHz	Detector Mode PK/QP/AV	Spectrum Reading Level dB μ V	Factor dB	Actual FS dB μ V/m	Limit @3m dB μ V/m	Margin dB
10440.00	Peak	42.44	2.14	44.58	68.20	-23.62
N/A						

Remark:

1. Measuring frequencies from 1 GHz to the 10th harmonic of highest fundamental frequency.
2. For above 1GHz, the EUT peak value was under average limit, therefore the Average value compliance with the average limit

Report No.: T201104D06-RP4

Test Mode	IEEE 802.11n 20 MHz / 5240MHz	Temp/Hum	22.4(°C)/ 67%RH
Test Item	Harmonic	Test Date	November 19, 2020
Polarize	Vertical	Test Engineer	Ray Li
Detector	Peak		

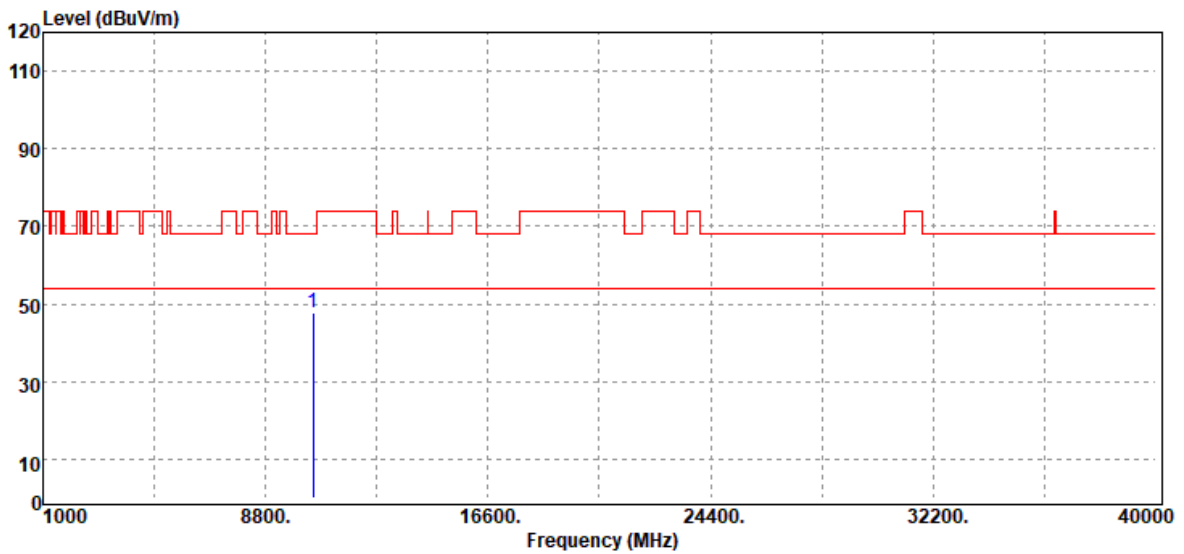

Freq. MHz	Detector Mode PK/QP/AV	Spectrum Reading Level dB μ V	Factor dB	Actual FS dB μ V/m	Limit @3m dB μ V/m	Margin dB
10480.00	Peak	45.51	2.11	47.62	68.20	-20.58
N/A						

Remark:

1. Measuring frequencies from 1 GHz to the 10th harmonic of highest fundamental frequency.
2. For above 1GHz, the EUT peak value was under average limit, therefore the Average value compliance with the average limit

Report No.: T201104D06-RP4

Test Mode	IEEE 802.11n 20 MHz / 5240MHz	Temp/Hum	22.4(°C)/ 67%RH
Test Item	Harmonic	Test Date	November 19, 2020
Polarize	Horizontal	Test Engineer	Ray Li
Detector	Peak		



Freq. MHz	Detector Mode PK/QP/AV	Spectrum Reading Level dB μ V	Factor dB	Actual FS dB μ V/m	Limit @3m dB μ V/m	Margin dB
10480.00	Peak	42.33	2.11	44.44	68.20	-23.76
N/A						

Remark:

1. Measuring frequencies from 1 GHz to the 10th harmonic of highest fundamental frequency.
2. For above 1GHz, the EUT peak value was under average limit, therefore the Average value compliance with the average limit

Report No.: T201104D06-RP4

Test Mode	IEEE 802.11n 40 MHz / 5190MHz	Temp/Hum	22.4(°C)/ 67%RH
Test Item	Harmonic	Test Date	November 19, 2020
Polarize	Vertical	Test Engineer	Ray Li
Detector	Peak		



Freq. MHz	Detector Mode PK/QP/AV	Spectrum Reading Level dBμV	Factor dB	Actual FS dBμV/m	Limit @3m dBμV/m	Margin dB
10380.00	Peak	42.22	2.13	44.35	68.20	-23.85
N/A						

Remark:

1. Measuring frequencies from 1 GHz to the 10th harmonic of highest fundamental frequency.
2. For above 1GHz, the EUT peak value was under average limit, therefore the Average value compliance with the average limit

Report No.: T201104D06-RP4

Test Mode	IEEE 802.11n 40 MHz / 5190MHz	Temp/Hum	22.4(°C)/ 67%RH
Test Item	Harmonic	Test Date	November 19, 2020
Polarize	Horizontal	Test Engineer	Ray Li
Detector	Peak		



Freq. MHz	Detector Mode PK/QP/AV	Spectrum Reading Level dB μ V	Factor dB	Actual FS dB μ V/m	Limit @3m dB μ V/m	Margin dB
10380.00	Peak	43.08	2.13	45.21	68.20	-22.99
N/A						

Remark:

1. Measuring frequencies from 1 GHz to the 10th harmonic of highest fundamental frequency.
2. For above 1GHz, the EUT peak value was under average limit, therefore the Average value compliance with the average limit

Report No.: T201104D06-RP4

Test Mode	IEEE 802.11n 40 MHz / 5230MHz	Temp/Hum	22.4(°C)/ 67%RH
Test Item	Harmonic	Test Date	November 19, 2020
Polarize	Vertical	Test Engineer	Ray Li
Detector	Peak		



Freq. MHz	Detector Mode PK/QP/AV	Spectrum Reading Level dB μ V	Factor dB	Actual FS dB μ V/m	Limit @3m dB μ V/m	Margin dB
10460.00	Peak	43.02	2.13	45.15	68.20	-23.05
N/A						

Remark:

1. Measuring frequencies from 1 GHz to the 10th harmonic of highest fundamental frequency.
2. For above 1GHz, the EUT peak value was under average limit, therefore the Average value compliance with the average limit

Report No.: T201104D06-RP4

Test Mode	IEEE 802.11n 40 MHz / 5230MHz	Temp/Hum	22.4(°C)/ 67%RH
Test Item	Harmonic	Test Date	November 19, 2020
Polarize	Horizontal	Test Engineer	Ray Li
Detector	Peak		



Freq. MHz	Detector Mode PK/QP/AV	Spectrum Reading Level dB μ V	Factor dB	Actual FS dB μ V/m	Limit @3m dB μ V/m	Margin dB
10460.00	Peak	42.26	2.13	44.39	68.20	-23.81
N/A						

Remark:

1. Measuring frequencies from 1 GHz to the 10th harmonic of highest fundamental frequency.
2. For above 1GHz, the EUT peak value was under average limit, therefore the Average value compliance with the average limit

Report No.: T201104D06-RP4

Test Mode	IEEE 802.11ac VHT80 / 5210MHZ	Temp/Hum	22.6(°C)/ 68%RH
Test Item	Harmonic	Test Date	November 20, 2020
Polarize	Vertical	Test Engineer	Ray Li
Detector	Peak		

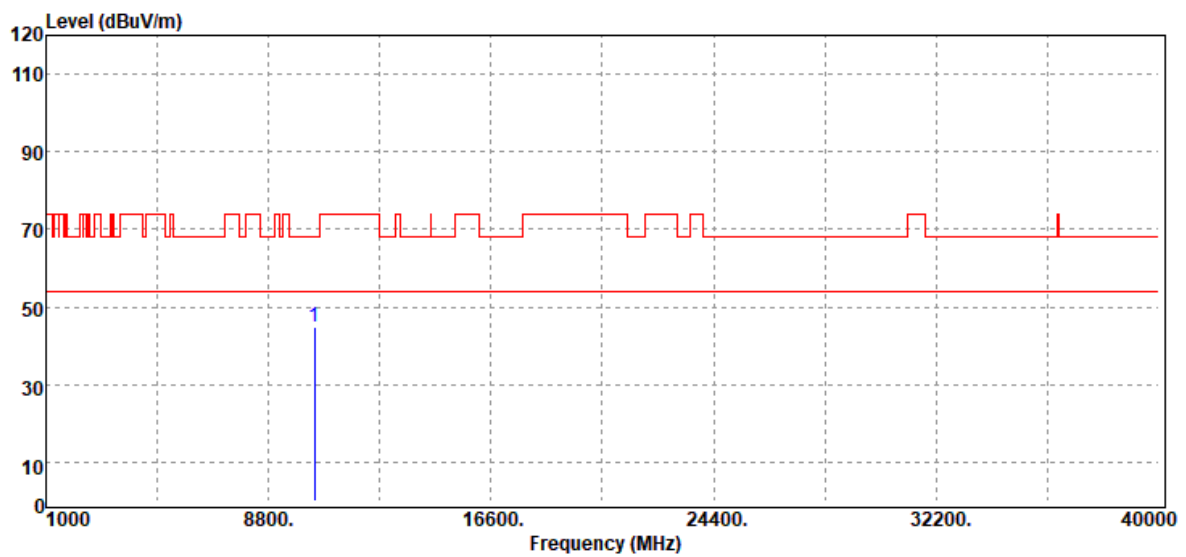

Freq. MHz	Detector Mode PK/QP/AV	Spectrum Reading Level dB μ V	Factor dB	Actual FS dB μ V/m	Limit @3m dB μ V/m	Margin dB
10420.00	Peak	42.51	2.13	44.64	68.20	-23.56
N/A						

Remark:

1. Measuring frequencies from 1 GHz to the 10th harmonic of highest fundamental frequency.
2. For above 1GHz, the EUT peak value was under average limit, therefore the Average value compliance with the average limit

Report No.: T201104D06-RP4

Test Mode	IEEE 802.11ac VHT80 / 5210MHZ	Temp/Hum	22.6(°C)/ 68%RH
Test Item	Harmonic	Test Date	November 20, 2020
Polarize	Horizontal	Test Engineer	Ray Li
Detector	Peak		



Freq. MHz	Detector Mode PK/QP/AV	Spectrum Reading Level dB μ V	Factor dB	Actual FS dB μ V/m	Limit @3m dB μ V/m	Margin dB
10420.00	Peak	41.44	2.13	43.57	68.20	-24.63
N/A						

Remark:

1. Measuring frequencies from 1 GHz to the 10th harmonic of highest fundamental frequency.
2. For above 1GHz, the EUT peak value was under average limit, therefore the Average value compliance with the average limit

Report No.: T201104D06-RP4

Test Data for UNII-2a

Test Mode	IEEE 802.11a / 5260 MHz	Temp/Hum	22.6(°C)/ 65%RH
Test Item	Harmonic	Test Date	November 18, 2020
Polarize	Vertical	Test Engineer	Ray Li
Detector	Peak		

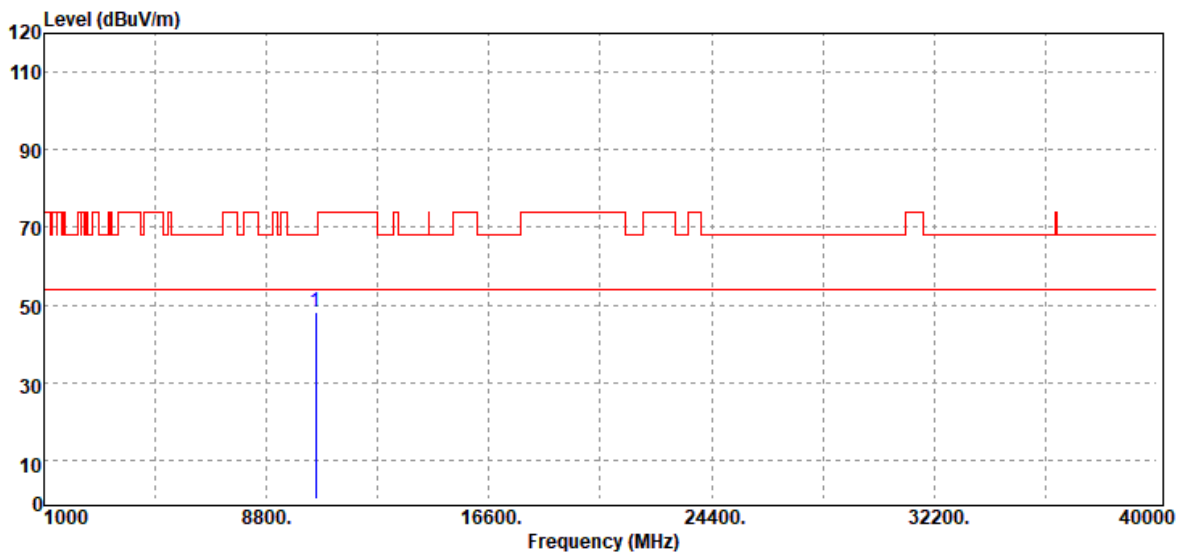

Freq. MHz	Detector Mode PK/QP/AV	Spectrum Reading Level dBμV	Factor dB	Actual FS dBμV/m	Limit @3m dBμV/m	Margin dB
10520.00	Peak	46.17	2.11	48.28	68.20	-19.92
N/A						

Remark:

1. Measuring frequencies from 1 GHz to the 10th harmonic of highest fundamental frequency.
2. For above 1GHz, the EUT peak value was under average limit, therefore the Average value compliance with the average limit

Report No.: T201104D06-RP4

Test Mode	IEEE 802.11a / 5260 MHz	Temp/Hum	22.6(°C)/ 65%RH
Test Item	Harmonic	Test Date	November 18, 2020
Polarize	Horizontal	Test Engineer	Ray Li
Detector	Peak		

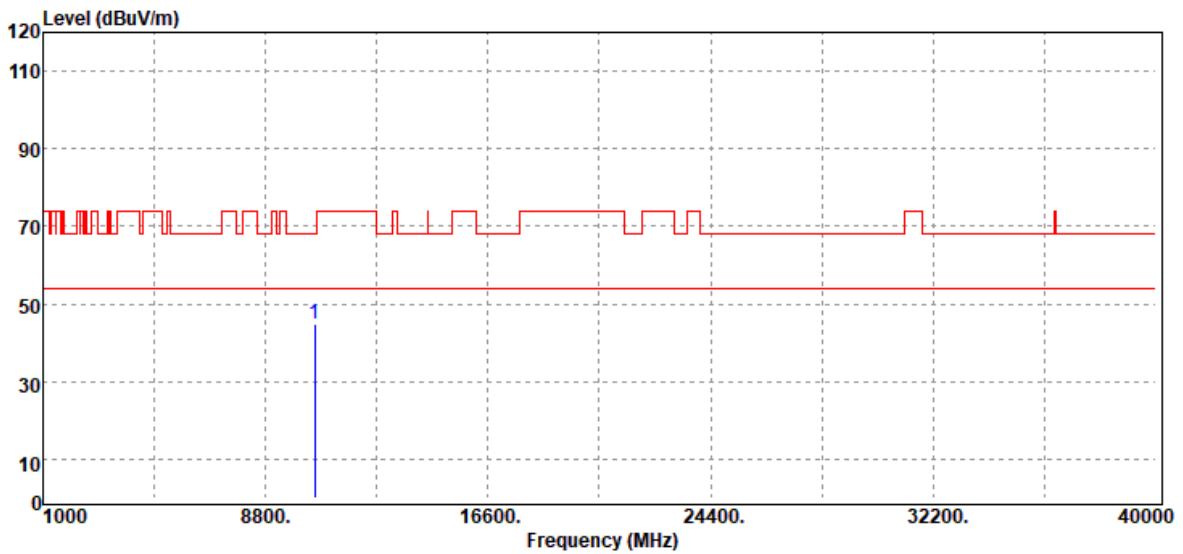

Freq. MHz	Detector Mode PK/QP/AV	Spectrum Reading Level dB μ V	Factor dB	Actual FS dB μ V/m	Limit @3m dB μ V/m	Margin dB
10520.00	Peak	42.67	2.11	44.78	68.20	-23.42
N/A						

Remark:

1. Measuring frequencies from 1 GHz to the 10th harmonic of highest fundamental frequency.
2. For above 1GHz, the EUT peak value was under average limit, therefore the Average value compliance with the average limit

Report No.: T201104D06-RP4

Test Mode	IEEE 802.11a / 5280 MHz	Temp/Hum	22.4(°C)/ 67%RH
Test Item	Harmonic	Test Date	November 19, 2020
Polarize	Vertical	Test Engineer	Ray Li
Detector	Peak		

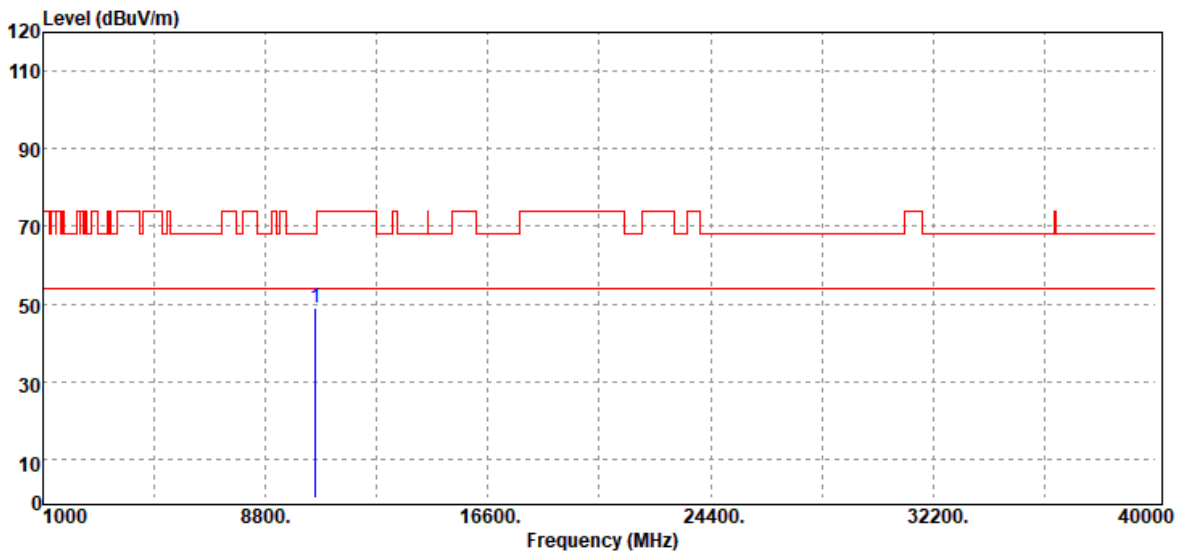

Freq. MHz	Detector Mode PK/QP/AV	Spectrum Reading Level dB μ V	Factor dB	Actual FS dB μ V/m	Limit @3m dB μ V/m	Margin dB
10560.00	Peak	46.70	2.15	48.85	68.20	-19.35
N/A						

Remark:

1. Measuring frequencies from 1 GHz to the 10th harmonic of highest fundamental frequency.
2. For above 1GHz, the EUT peak value was under average limit, therefore the Average value compliance with the average limit

Report No.: T201104D06-RP4

Test Mode	IEEE 802.11a / 5280 MHz	Temp/Hum	22.4(°C)/ 67%RH
Test Item	Harmonic	Test Date	November 19, 2020
Polarize	Horizontal	Test Engineer	Ray Li
Detector	Peak		

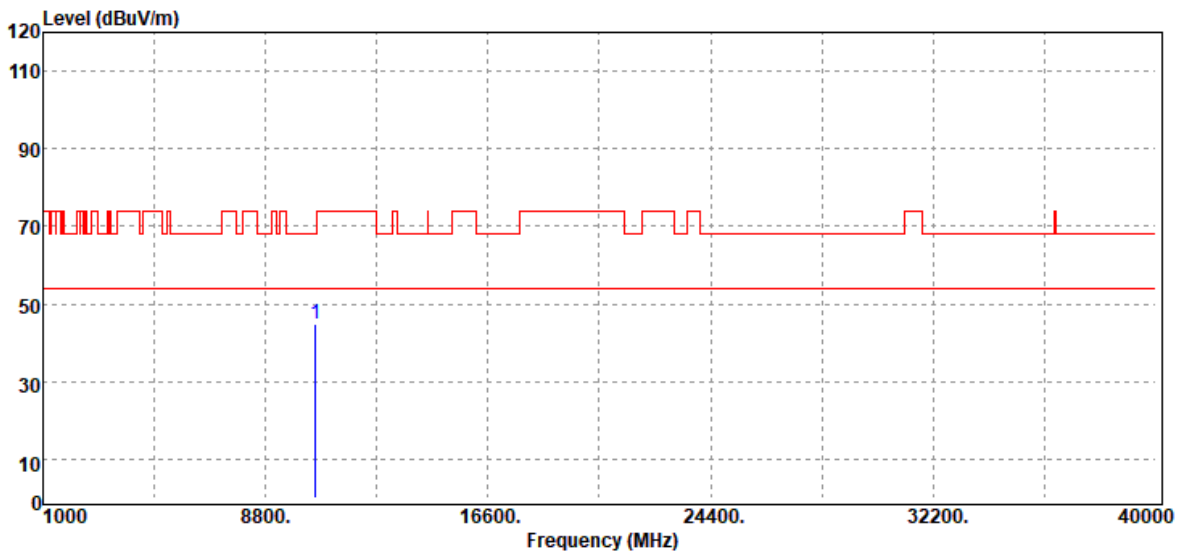

Freq. MHz	Detector Mode PK/QP/AV	Spectrum Reading Level dB μ V	Factor dB	Actual FS dB μ V/m	Limit @3m dB μ V/m	Margin dB
10560.00	Peak	42.51	2.15	44.66	68.20	-23.54
N/A						

Remark:

1. Measuring frequencies from 1 GHz to the 10th harmonic of highest fundamental frequency.
2. For above 1GHz, the EUT peak value was under average limit, therefore the Average value compliance with the average limit

Report No.: T201104D06-RP4

Test Mode	IEEE 802.11a / 5320 MHz	Temp/Hum	22.4(°C)/ 67%RH
Test Item	Harmonic	Test Date	November 19, 2020
Polarize	Vertical	Test Engineer	Ray Li
Detector	Peak		

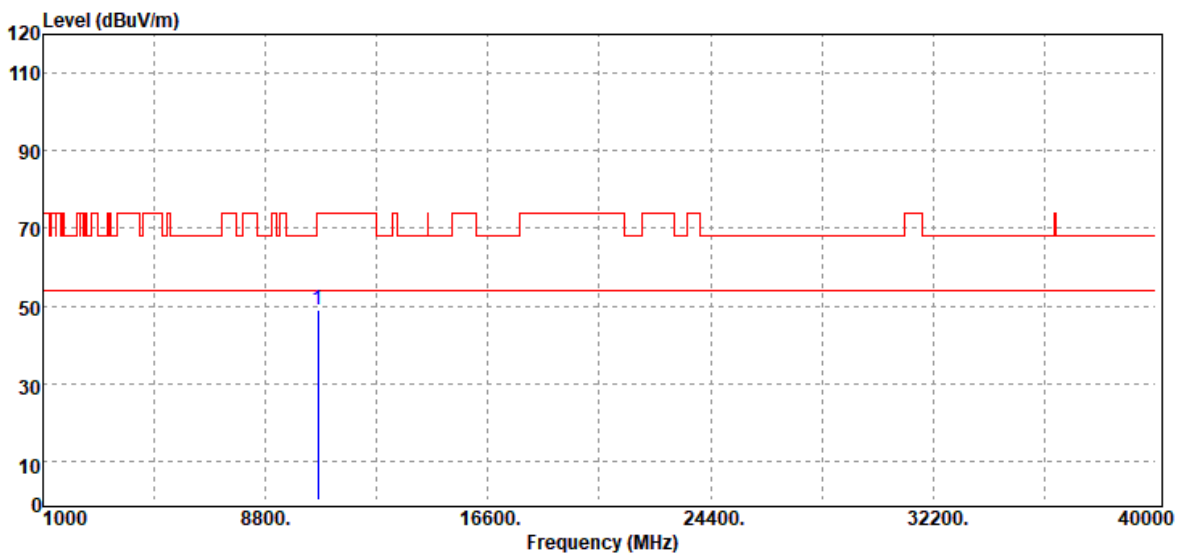

Freq. MHz	Detector Mode PK/QP/AV	Spectrum Reading Level dB μ V	Factor dB	Actual FS dB μ V/m	Limit @3m dB μ V/m	Margin dB
10640.00	Peak	46.62	2.30	48.92	74.00	-25.08
N/A						

Remark:

1. Measuring frequencies from 1 GHz to the 10th harmonic of highest fundamental frequency.
2. For above 1GHz, the EUT peak value was under average limit, therefore the Average value compliance with the average limit

Report No.: T201104D06-RP4

Test Mode	IEEE 802.11a / 5320 MHz	Temp/Hum	22.4(°C)/ 67%RH
Test Item	Harmonic	Test Date	November 19, 2020
Polarize	Horizontal	Test Engineer	Ray Li
Detector	Peak		



Freq. MHz	Detector Mode PK/QP/AV	Spectrum Reading Level dB μ V	Factor dB	Actual FS dB μ V/m	Limit @3m dB μ V/m	Margin dB
10640.00	Peak	42.13	2.30	44.43	74.00	-29.57
N/A						

Remark:

1. Measuring frequencies from 1 GHz to the 10th harmonic of highest fundamental frequency.
2. For above 1GHz, the EUT peak value was under average limit, therefore the Average value compliance with the average limit

Report No.: T201104D06-RP4

Test Mode	IEEE 802.11n 20 MHz / 5260 MHz	Temp/Hum	22.4(°C)/ 67%RH
Test Item	Harmonic	Test Date	November 19, 2020
Polarize	Vertical	Test Engineer	Ray Li
Detector	Peak		



Freq. MHz	Detector Mode PK/QP/AV	Spectrum Reading Level dB μ V	Factor dB	Actual FS dB μ V/m	Limit @3m dB μ V/m	Margin dB
10520.00	Peak	44.06	2.11	46.17	68.20	-22.03
N/A						

Remark:

1. Measuring frequencies from 1 GHz to the 10th harmonic of highest fundamental frequency.
2. For above 1GHz, the EUT peak value was under average limit, therefore the Average value compliance with the average limit

Report No.: T201104D06-RP4

Test Mode	IEEE 802.11n 20 MHz / 5260 MHz	Temp/Hum	22.4(°C)/ 67%RH
Test Item	Harmonic	Test Date	November 19, 2020
Polarize	Horizontal	Test Engineer	Ray Li
Detector	Peak		



Freq. MHz	Detector Mode PK/QP/AV	Spectrum Reading Level dB μ V	Factor dB	Actual FS dB μ V/m	Limit @3m dB μ V/m	Margin dB
10520.00	Peak	42.40	2.11	44.51	68.20	-23.69
N/A						

Remark:

1. Measuring frequencies from 1 GHz to the 10th harmonic of highest fundamental frequency.
2. For above 1GHz, the EUT peak value was under average limit, therefore the Average value compliance with the average limit

Report No.: T201104D06-RP4

Test Mode	IEEE 802.11n 20 MHz / 5280 MHz	Temp/Hum	22.4(°C)/ 67%RH
Test Item	Harmonic	Test Date	November 19, 2020
Polarize	Vertical	Test Engineer	Ray Li
Detector	Peak		



Freq. MHz	Detector Mode PK/QP/AV	Spectrum Reading Level dB μ V	Factor dB	Actual FS dB μ V/m	Limit @3m dB μ V/m	Margin dB
10560.00	Peak	44.62	2.15	46.77	68.20	-21.43
N/A						

Remark:

1. Measuring frequencies from 1 GHz to the 10th harmonic of highest fundamental frequency.
2. For above 1GHz, the EUT peak value was under average limit, therefore the Average value compliance with the average limit

Report No.: T201104D06-RP4

Test Mode	IEEE 802.11n 20 MHz / 5280 MHz	Temp/Hum	22.4(°C)/ 67%RH
Test Item	Harmonic	Test Date	November 19, 2020
Polarize	Horizontal	Test Engineer	Ray Li
Detector	Peak		



Freq. MHz	Detector Mode PK/QP/AV	Spectrum Reading Level dB μ V	Factor dB	Actual FS dB μ V/m	Limit @3m dB μ V/m	Margin dB
10560.00	Peak	42.06	2.15	44.21	68.20	-23.99
N/A						

Remark:

1. Measuring frequencies from 1 GHz to the 10th harmonic of highest fundamental frequency.
2. For above 1GHz, the EUT peak value was under average limit, therefore the Average value compliance with the average limit

Report No.: T201104D06-RP4

Test Mode	IEEE 802.11n 20 MHz / 5320 MHz	Temp/Hum	22.4(°C)/ 67%RH
Test Item	Harmonic	Test Date	November 19, 2020
Polarize	Vertical	Test Engineer	Ray Li
Detector	Peak		



Freq. MHz	Detector Mode PK/QP/AV	Spectrum Reading Level dB μ V	Factor dB	Actual FS dB μ V/m	Limit @3m dB μ V/m	Margin dB
10640.00	Peak	42.85	2.30	45.15	74.00	-28.85
N/A						

Remark:

1. Measuring frequencies from 1 GHz to the 10th harmonic of highest fundamental frequency.
2. For above 1GHz, the EUT peak value was under average limit, therefore the Average value compliance with the average limit

Report No.: T201104D06-RP4

Test Mode	IEEE 802.11n 20 MHz / 5320 MHz	Temp/Hum	22.4(°C)/ 67%RH
Test Item	Harmonic	Test Date	November 19, 2020
Polarize	Horizontal	Test Engineer	Ray Li
Detector	Peak		

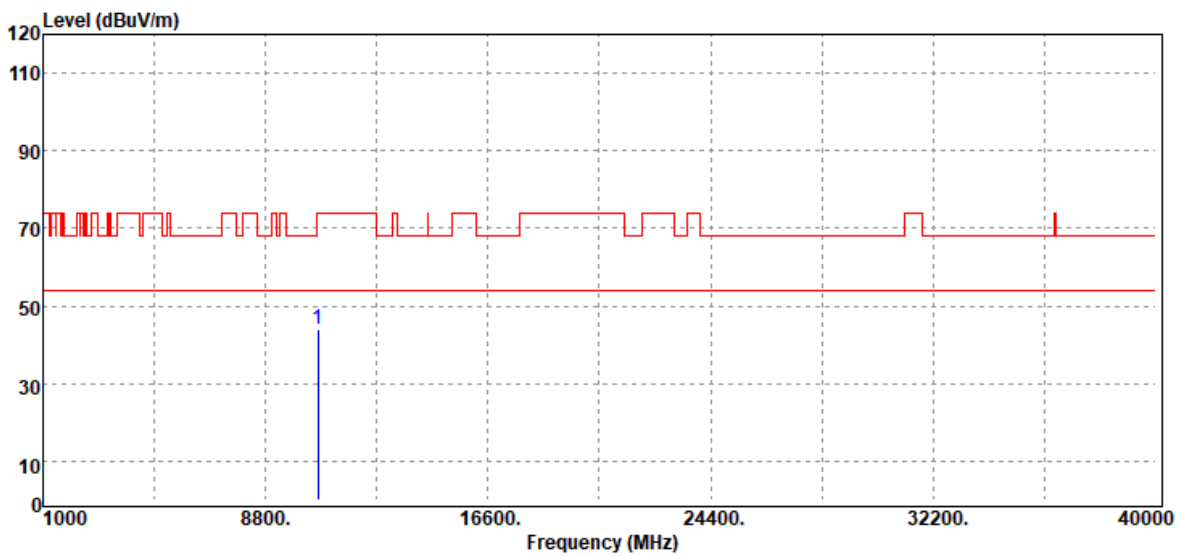

Freq. MHz	Detector Mode PK/QP/AV	Spectrum Reading Level dB μ V	Factor dB	Actual FS dB μ V/m	Limit @3m dB μ V/m	Margin dB
10640.00	Peak	41.89	2.30	44.19	74.00	-29.81
N/A						

Remark:

1. Measuring frequencies from 1 GHz to the 10th harmonic of highest fundamental frequency.
2. For above 1GHz, the EUT peak value was under average limit, therefore the Average value compliance with the average limit

Report No.: T201104D06-RP4

Test Mode	IEEE 802.11n 40 MHz / 5270 MHz	Temp/Hum	22.4(°C)/ 67%RH
Test Item	Harmonic	Test Date	November 19, 2020
Polarize	Vertical	Test Engineer	Ray Li
Detector	Peak		

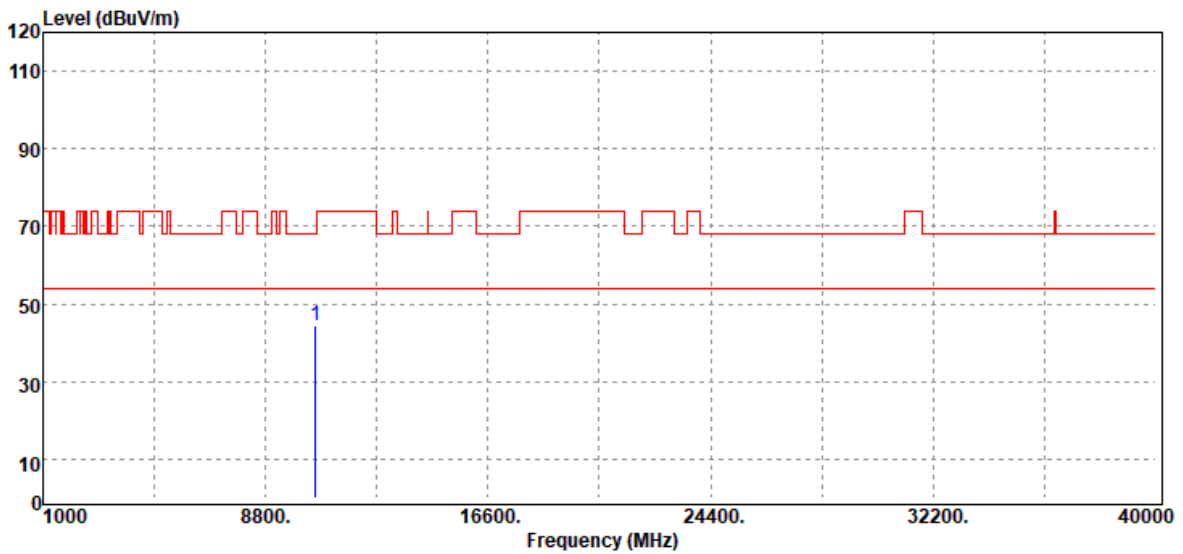

Freq. MHz	Detector Mode PK/QP/AV	Spectrum Reading Level dB μ V	Factor dB	Actual FS dB μ V/m	Limit @3m dB μ V/m	Margin dB
10540.00	Peak	42.12	2.14	44.26	68.20	-23.94
N/A						

Remark:

1. Measuring frequencies from 1 GHz to the 10th harmonic of highest fundamental frequency.
2. For above 1GHz, the EUT peak value was under average limit, therefore the Average value compliance with the average limit

Report No.: T201104D06-RP4

Test Mode	IEEE 802.11n 40 MHz / 5270 MHz	Temp/Hum	22.4(°C)/ 67%RH
Test Item	Harmonic	Test Date	November 19, 2020
Polarize	Horizontal	Test Engineer	Ray Li
Detector	Peak		



Freq. MHz	Detector Mode PK/QP/AV	Spectrum Reading Level dB μ V	Factor dB	Actual FS dB μ V/m	Limit @3m dB μ V/m	Margin dB
10540.00	Peak	41.92	2.14	44.06	68.20	-24.14
N/A						

Remark:

1. Measuring frequencies from 1 GHz to the 10th harmonic of highest fundamental frequency.
2. For above 1GHz, the EUT peak value was under average limit, therefore the Average value compliance with the average limit

Report No.: T201104D06-RP4

Test Mode	IEEE 802.11n 40 MHz / 5310 MHz	Temp/Hum	22.4(°C)/ 67%RH
Test Item	Harmonic	Test Date	November 19, 2020
Polarize	Vertical	Test Engineer	Ray Li
Detector	Peak		



Freq. MHz	Detector Mode PK/QP/AV	Spectrum Reading Level dB μ V	Factor dB	Actual FS dB μ V/m	Limit @3m dB μ V/m	Margin dB
10620.00	Peak	42.42	2.24	44.66	74.00	-29.34
N/A						

Remark:

1. Measuring frequencies from 1 GHz to the 10th harmonic of highest fundamental frequency.
2. For above 1GHz, the EUT peak value was under average limit, therefore the Average value compliance with the average limit

Report No.: T201104D06-RP4

Test Mode	IEEE 802.11n 40 MHz / 5310 MHz	Temp/Hum	22.4(°C)/ 67%RH
Test Item	Harmonic	Test Date	November 19, 2020
Polarize	Horizontal	Test Engineer	Ray Li
Detector	Peak		



Freq. MHz	Detector Mode PK/QP/AV	Spectrum Reading Level dB μ V	Factor dB	Actual FS dB μ V/m	Limit @3m dB μ V/m	Margin dB
10620.00	Peak	41.96	2.24	44.20	74.00	-29.80
N/A						

Remark:

1. Measuring frequencies from 1 GHz to the 10th harmonic of highest fundamental frequency.
2. For above 1GHz, the EUT peak value was under average limit, therefore the Average value compliance with the average limit

Report No.: T201104D06-RP4

Test Mode	IEEE 802.11ac VHT80 / 5290 MHz	Temp/Hum	22.6(°C)/ 68%RH
Test Item	Harmonic	Test Date	November 20, 2020
Polarize	Vertical	Test Engineer	Ray Li
Detector	Peak		

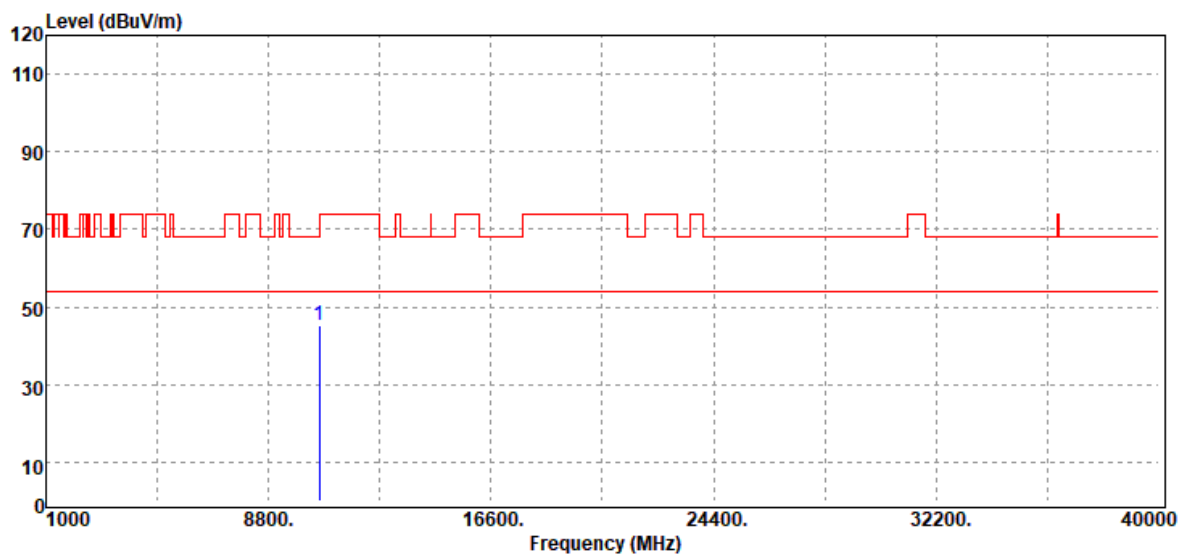

Freq. MHz	Detector Mode PK/QP/AV	Spectrum Reading Level dB μ V	Factor dB	Actual FS dB μ V/m	Limit @3m dB μ V/m	Margin dB
10580.00	Peak	43.18	2.17	45.35	68.20	-22.85
N/A						

Remark:

1. Measuring frequencies from 1 GHz to the 10th harmonic of highest fundamental frequency.
2. For above 1GHz, the EUT peak value was under average limit, therefore the Average value compliance with the average limit

Report No.: T201104D06-RP4

Test Mode	IEEE 802.11ac VHT80 / 5290 MHz	Temp/Hum	22.6(°C)/ 68%RH
Test Item	Harmonic	Test Date	November 20, 2020
Polarize	Horizontal	Test Engineer	Ray Li
Detector	Peak		

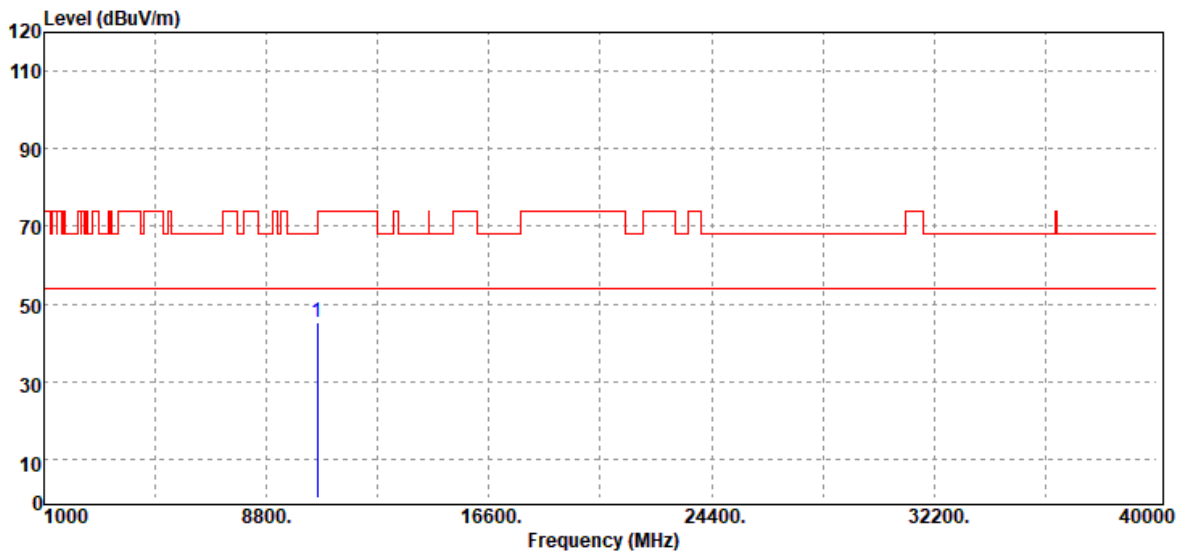

Freq. MHz	Detector Mode PK/QP/AV	Spectrum Reading Level dB μ V	Factor dB	Actual FS dB μ V/m	Limit @3m dB μ V/m	Margin dB
10580.00	Peak	43.25	2.17	45.42	68.20	-22.78
N/A						

Remark:

1. Measuring frequencies from 1 GHz to the 10th harmonic of highest fundamental frequency.
2. For above 1GHz, the EUT peak value was under average limit, therefore the Average value compliance with the average limit

Report No.: T201104D06-RP4

Test Data for UNII-2c

Test Mode	IEEE 802.11a / 5500 MHz	Temp/Hum	22.4(°C)/ 67%RH
Test Item	Harmonic	Test Date	November 19, 2020
Polarize	Vertical	Test Engineer	Ray Li
Detector	Peak		

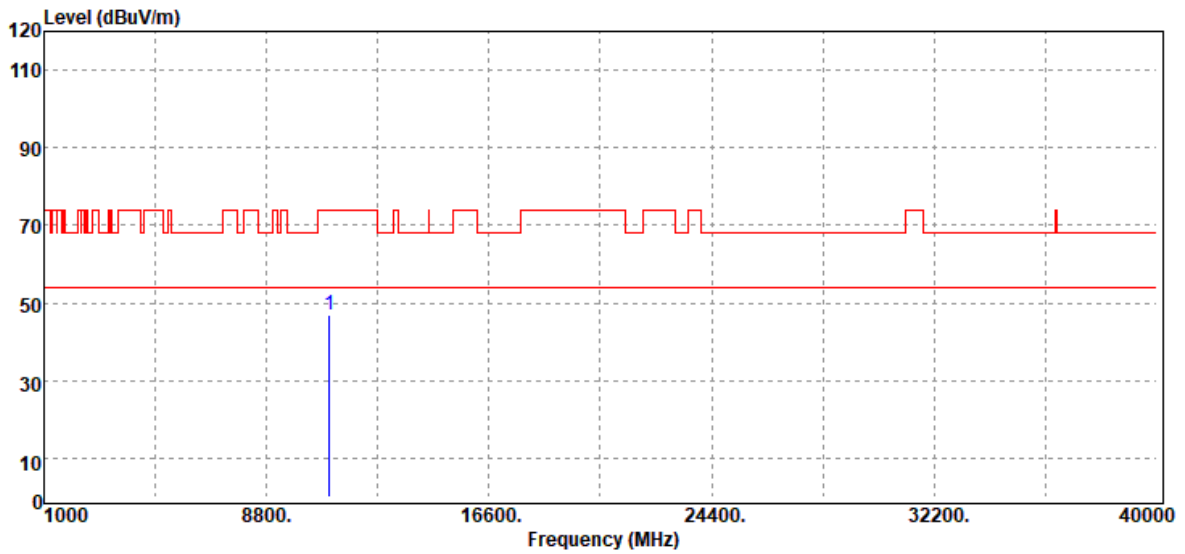

Freq. MHz	Detector Mode PK/QP/AV	Spectrum Reading Level dBμV	Factor dB	Actual FS dBμV/m	Limit @3m dBμV/m	Margin dB
11000.00	Peak	43.53	3.22	46.75	74.00	-27.25
N/A						

Remark:

1. Measuring frequencies from 1 GHz to the 10th harmonic of highest fundamental frequency.
2. For above 1GHz, the EUT peak value was under average limit, therefore the Average value compliance with the average limit

Report No.: T201104D06-RP4

Test Mode	IEEE 802.11a / 5500 MHz	Temp/Hum	22.4(°C)/ 67%RH
Test Item	Harmonic	Test Date	November 19, 2020
Polarize	Horizontal	Test Engineer	Ray Li
Detector	Peak		



Freq. MHz	Detector Mode PK/QP/AV	Spectrum Reading Level dB μ V	Factor dB	Actual FS dB μ V/m	Limit @3m dB μ V/m	Margin dB
11000.00	Peak	41.55	3.22	44.77	74.00	-29.23
N/A						

Remark:

1. Measuring frequencies from 1 GHz to the 10th harmonic of highest fundamental frequency.
2. For above 1GHz, the EUT peak value was under average limit, therefore the Average value compliance with the average limit

Report No.: T201104D06-RP4

Test Mode	IEEE 802.11a / 5580 MHz	Temp/Hum	22.4(°C)/ 67%RH
Test Item	Harmonic	Test Date	November 19, 2020
Polarize	Vertical	Test Engineer	Ray Li
Detector	Peak		

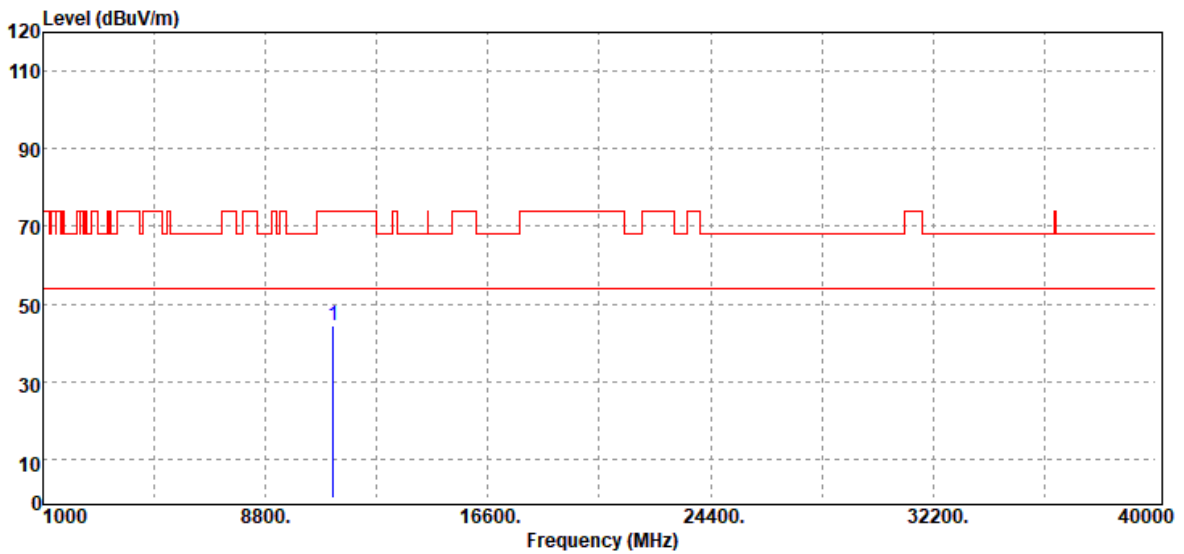

Freq. MHz	Detector Mode PK/QP/AV	Spectrum Reading Level dB μ V	Factor dB	Actual FS dB μ V/m	Limit @3m dB μ V/m	Margin dB
11160.00	Peak	41.28	3.36	44.64	74.00	-29.36
N/A						

Remark:

1. Measuring frequencies from 1 GHz to the 10th harmonic of highest fundamental frequency.
2. For above 1GHz, the EUT peak value was under average limit, therefore the Average value compliance with the average limit

Report No.: T201104D06-RP4

Test Mode	IEEE 802.11a / 5580 MHz	Temp/Hum	22.4(°C)/ 67%RH
Test Item	Harmonic	Test Date	November 19, 2020
Polarize	Horizontal	Test Engineer	Ray Li
Detector	Peak		

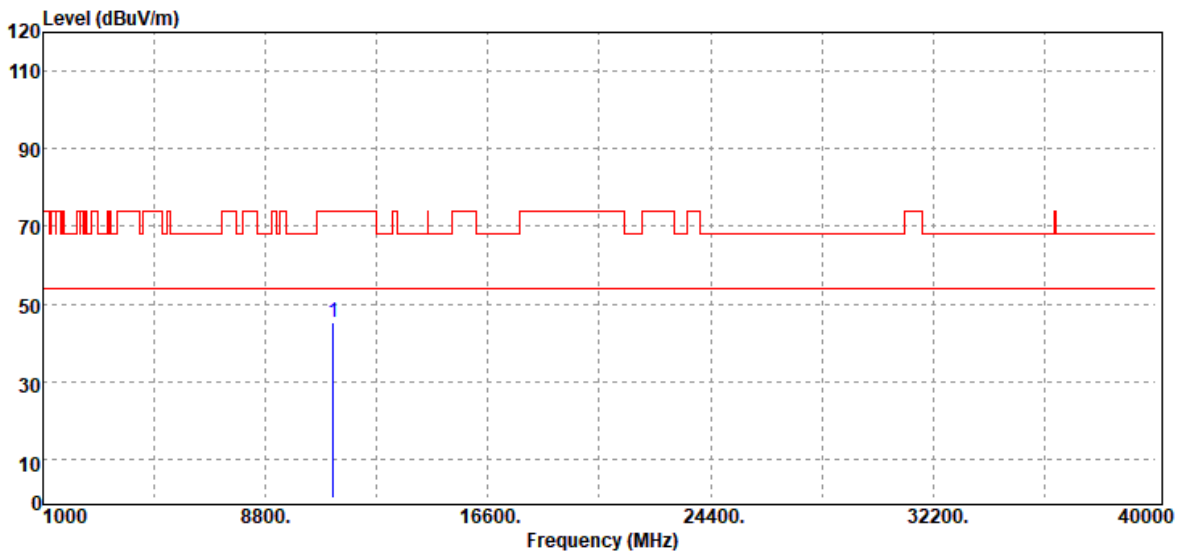

Freq. MHz	Detector Mode PK/QP/AV	Spectrum Reading Level dB μ V	Factor dB	Actual FS dB μ V/m	Limit @3m dB μ V/m	Margin dB
11160.00	Peak	42.09	3.36	45.45	74.00	-28.55
N/A						

Remark:

1. Measuring frequencies from 1 GHz to the 10th harmonic of highest fundamental frequency.
2. For above 1GHz, the EUT peak value was under average limit, therefore the Average value compliance with the average limit

Report No.: T201104D06-RP4

Test Mode	IEEE 802.11a / 5700 MHz	Temp/Hum	22.4(°C)/ 67%RH
Test Item	Harmonic	Test Date	November 19, 2020
Polarize	Vertical	Test Engineer	Ray Li
Detector	Peak		

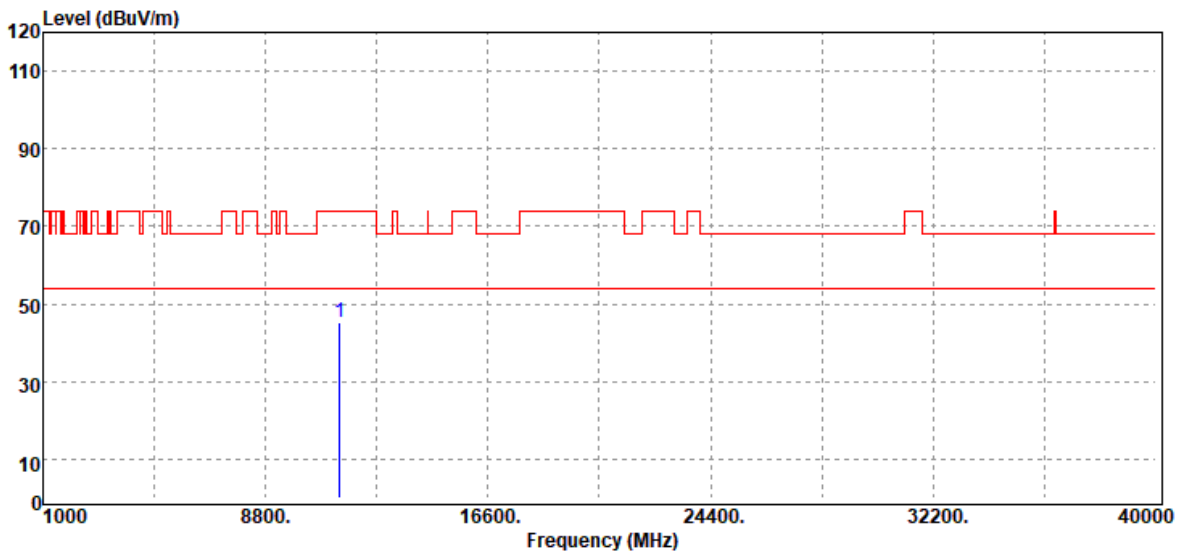

Freq. MHz	Detector Mode PK/QP/AV	Spectrum Reading Level dB μ V	Factor dB	Actual FS dB μ V/m	Limit @3m dB μ V/m	Margin dB
11400.00	Peak	42.39	2.82	45.21	74.00	-28.79
N/A						

Remark:

1. Measuring frequencies from 1 GHz to the 10th harmonic of highest fundamental frequency.
2. For above 1GHz, the EUT peak value was under average limit, therefore the Average value compliance with the average limit

Report No.: T201104D06-RP4

Test Mode	IEEE 802.11a / 5700 MHz	Temp/Hum	22.4(°C)/ 67%RH
Test Item	Harmonic	Test Date	November 19, 2020
Polarize	Horizontal	Test Engineer	Ray Li
Detector	Peak		



Freq. MHz	Detector Mode PK/QP/AV	Spectrum Reading Level dB μ V	Factor dB	Actual FS dB μ V/m	Limit @3m dB μ V/m	Margin dB
11400.00	Peak	41.20	2.82	44.02	74.00	-29.98
N/A						

Remark:

1. Measuring frequencies from 1 GHz to the 10th harmonic of highest fundamental frequency.
2. For above 1GHz, the EUT peak value was under average limit, therefore the Average value compliance with the average limit

Report No.: T201104D06-RP4

Test Mode	IEEE 802.11n 20 MHz / 5500 MHz	Temp/Hum	22.4(°C)/ 67%RH
Test Item	Harmonic	Test Date	November 19, 2020
Polarize	Vertical	Test Engineer	Ray Li
Detector	Peak		

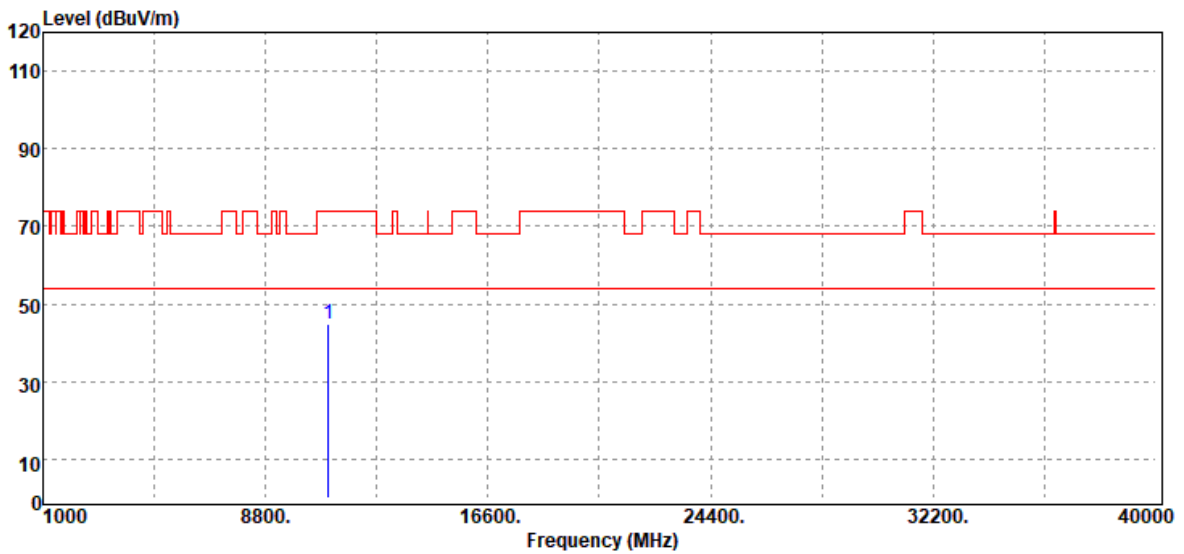

Freq. MHz	Detector Mode PK/QP/AV	Spectrum Reading Level dB μ V	Factor dB	Actual FS dB μ V/m	Limit @3m dB μ V/m	Margin dB
11000.00	Peak	41.47	3.22	44.69	74.00	-29.31
N/A						

Remark:

1. Measuring frequencies from 1 GHz to the 10th harmonic of highest fundamental frequency.
2. For above 1GHz, the EUT peak value was under average limit, therefore the Average value compliance with the average limit

Report No.: T201104D06-RP4

Test Mode	IEEE 802.11n 20 MHz / 5500 MHz	Temp/Hum	22.4(°C)/ 67%RH
Test Item	Harmonic	Test Date	November 19, 2020
Polarize	Horizontal	Test Engineer	Ray Li
Detector	Peak		

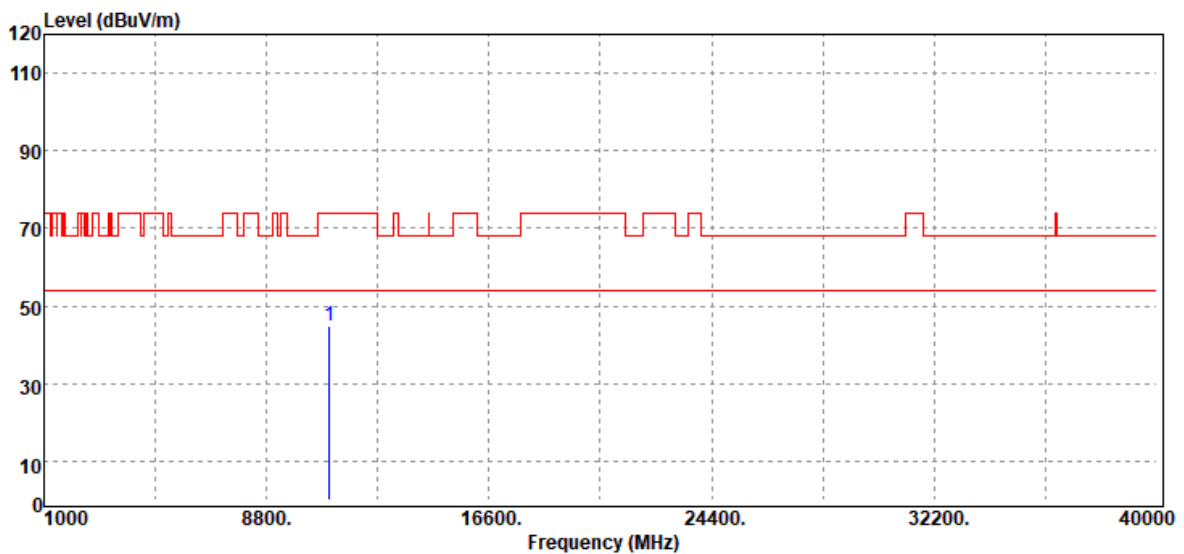

Freq. MHz	Detector Mode PK/QP/AV	Spectrum Reading Level dB μ V	Factor dB	Actual FS dB μ V/m	Limit @3m dB μ V/m	Margin dB
11000.00	Peak	41.53	3.22	44.75	74.00	-29.25
N/A						

Remark:

1. Measuring frequencies from 1 GHz to the 10th harmonic of highest fundamental frequency.
2. For above 1GHz, the EUT peak value was under average limit, therefore the Average value compliance with the average limit

Report No.: T201104D06-RP4

Test Mode	IEEE 802.11n 20 MHz / 5580 MHz	Temp/Hum	22.4(°C)/ 67%RH
Test Item	Harmonic	Test Date	November 19, 2020
Polarize	Vertical	Test Engineer	Ray Li
Detector	Peak		

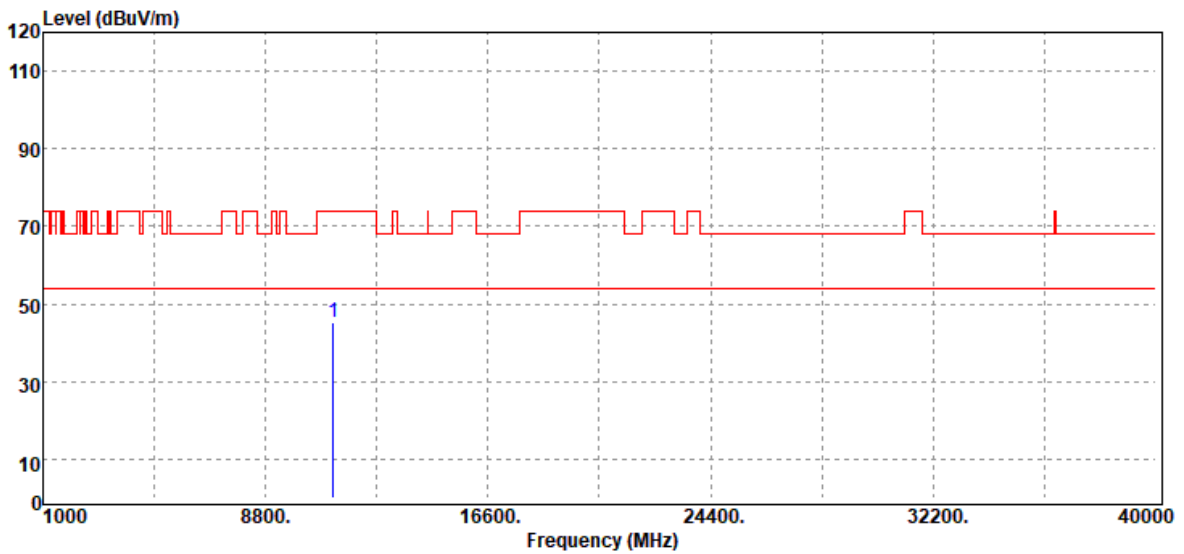

Freq. MHz	Detector Mode PK/QP/AV	Spectrum Reading Level dB μ V	Factor dB	Actual FS dB μ V/m	Limit @3m dB μ V/m	Margin dB
11160.00	Peak	42.03	3.36	45.39	74.00	-28.61
N/A						

Remark:

1. Measuring frequencies from 1 GHz to the 10th harmonic of highest fundamental frequency.
2. For above 1GHz, the EUT peak value was under average limit, therefore the Average value compliance with the average limit

Report No.: T201104D06-RP4

Test Mode	IEEE 802.11n 20 MHz / 5580 MHz	Temp/Hum	22.4(°C)/ 67%RH
Test Item	Harmonic	Test Date	November 19, 2020
Polarize	Horizontal	Test Engineer	Ray Li
Detector	Peak		



Freq. MHz	Detector Mode PK/QP/AV	Spectrum Reading Level dB μ V	Factor dB	Actual FS dB μ V/m	Limit @3m dB μ V/m	Margin dB
11160.00	Peak	40.63	3.36	43.99	74.00	-30.01
N/A						

Remark:

1. Measuring frequencies from 1 GHz to the 10th harmonic of highest fundamental frequency.
2. For above 1GHz, the EUT peak value was under average limit, therefore the Average value compliance with the average limit

Report No.: T201104D06-RP4

Test Mode	IEEE 802.11n 20 MHz / 5700 MHz	Temp/Hum	22.4(°C)/ 67%RH
Test Item	Harmonic	Test Date	November 19, 2020
Polarize	Vertical	Test Engineer	Ray Li
Detector	Peak		

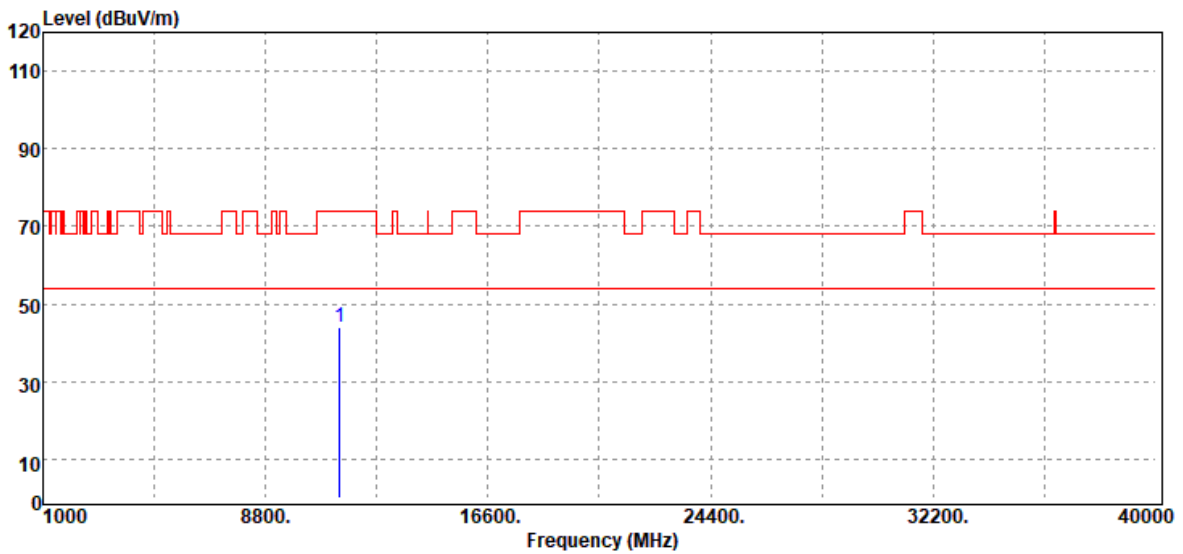

Freq. MHz	Detector Mode PK/QP/AV	Spectrum Reading Level dB μ V	Factor dB	Actual FS dB μ V/m	Limit @3m dB μ V/m	Margin dB
11400.00	Peak	41.05	2.82	43.87	74.00	-30.13
N/A						

Remark:

1. Measuring frequencies from 1 GHz to the 10th harmonic of highest fundamental frequency.
2. For above 1GHz, the EUT peak value was under average limit, therefore the Average value compliance with the average limit

Report No.: T201104D06-RP4

Test Mode	IEEE 802.11n 20 MHz / 5700 MHz	Temp/Hum	22.4(°C)/ 67%RH
Test Item	Harmonic	Test Date	November 19, 2020
Polarize	Horizontal	Test Engineer	Ray Li
Detector	Peak		



Freq. MHz	Detector Mode PK/QP/AV	Spectrum Reading Level dB μ V	Factor dB	Actual FS dB μ V/m	Limit @3m dB μ V/m	Margin dB
11400.00	Peak	42.14	2.82	44.96	74.00	-29.04
N/A						

Remark:

1. Measuring frequencies from 1 GHz to the 10th harmonic of highest fundamental frequency.
2. For above 1GHz, the EUT peak value was under average limit, therefore the Average value compliance with the average limit

Report No.: T201104D06-RP4

Test Mode	IEEE 802.11n 40 MHz / 5510 MHz	Temp/Hum	22.4(°C)/ 67%RH
Test Item	Harmonic	Test Date	November 19, 2020
Polarize	Vertical	Test Engineer	Ray Li
Detector	Peak		

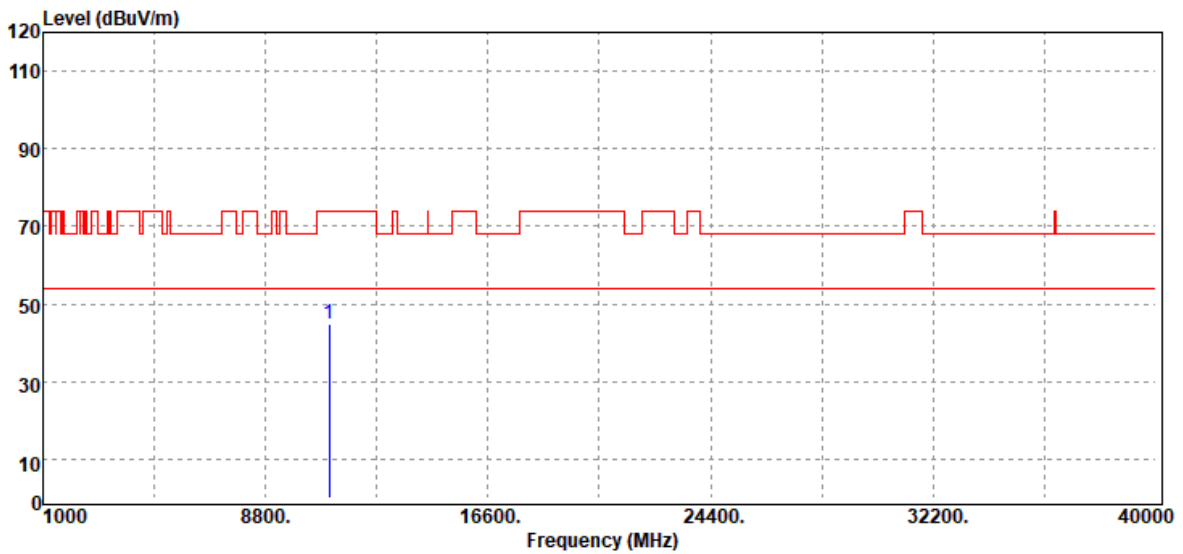

Freq. MHz	Detector Mode PK/QP/AV	Spectrum Reading Level dB μ V	Factor dB	Actual FS dB μ V/m	Limit @3m dB μ V/m	Margin dB
11020.00	Peak	41.55	3.13	44.68	74.00	-29.32
N/A						

Remark:

1. Measuring frequencies from 1 GHz to the 10th harmonic of highest fundamental frequency.
2. For above 1GHz, the EUT peak value was under average limit, therefore the Average value compliance with the average limit

Report No.: T201104D06-RP4

Test Mode	IEEE 802.11n 40 MHz / 5510 MHz	Temp/Hum	22.4(°C)/ 67%RH
Test Item	Harmonic	Test Date	November 19, 2020
Polarize	Horizontal	Test Engineer	Ray Li
Detector	Peak		



Freq. MHz	Detector Mode PK/QP/AV	Spectrum Reading Level dB μ V	Factor dB	Actual FS dB μ V/m	Limit @3m dB μ V/m	Margin dB
11020.00	Peak	41.48	3.13	44.61	74.00	-29.39
N/A						

Remark:

1. Measuring frequencies from 1 GHz to the 10th harmonic of highest fundamental frequency.
2. For above 1GHz, the EUT peak value was under average limit, therefore the Average value compliance with the average limit

Report No.: T201104D06-RP4

Test Mode	IEEE 802.11n 40 MHz / 5550 MHz	Temp/Hum	22.4(°C)/ 67%RH
Test Item	Harmonic	Test Date	November 19, 2020
Polarize	Vertical	Test Engineer	Ray Li
Detector	Peak		



Freq. MHz	Detector Mode PK/QP/AV	Spectrum Reading Level dB μ V	Factor dB	Actual FS dB μ V/m	Limit @3m dB μ V/m	Margin dB
11100.00	Peak	42.63	3.44	46.07	74.00	-27.93
N/A						

Remark:

1. Measuring frequencies from 1 GHz to the 10th harmonic of highest fundamental frequency.
2. For above 1GHz, the EUT peak value was under average limit, therefore the Average value compliance with the average limit

Report No.: T201104D06-RP4

Test Mode	IEEE 802.11n 40 MHz / 5550 MHz	Temp/Hum	22.4(°C)/ 67%RH
Test Item	Harmonic	Test Date	November 19, 2020
Polarize	Horizontal	Test Engineer	Ray Li
Detector	Peak		



Freq. MHz	Detector Mode PK/QP/AV	Spectrum Reading Level dB μ V	Factor dB	Actual FS dB μ V/m	Limit @3m dB μ V/m	Margin dB
11100.00	Peak	41.11	3.44	44.55	74.00	-29.45
N/A						

Remark:

1. Measuring frequencies from 1 GHz to the 10th harmonic of highest fundamental frequency.
2. For above 1GHz, the EUT peak value was under average limit, therefore the Average value compliance with the average limit

Report No.: T201104D06-RP4

Test Mode	IEEE 802.11n 40 MHz / 5670 MHz	Temp/Hum	22.4(°C)/ 67%RH
Test Item	Harmonic	Test Date	November 19, 2020
Polarize	Vertical	Test Engineer	Ray Li
Detector	Peak		

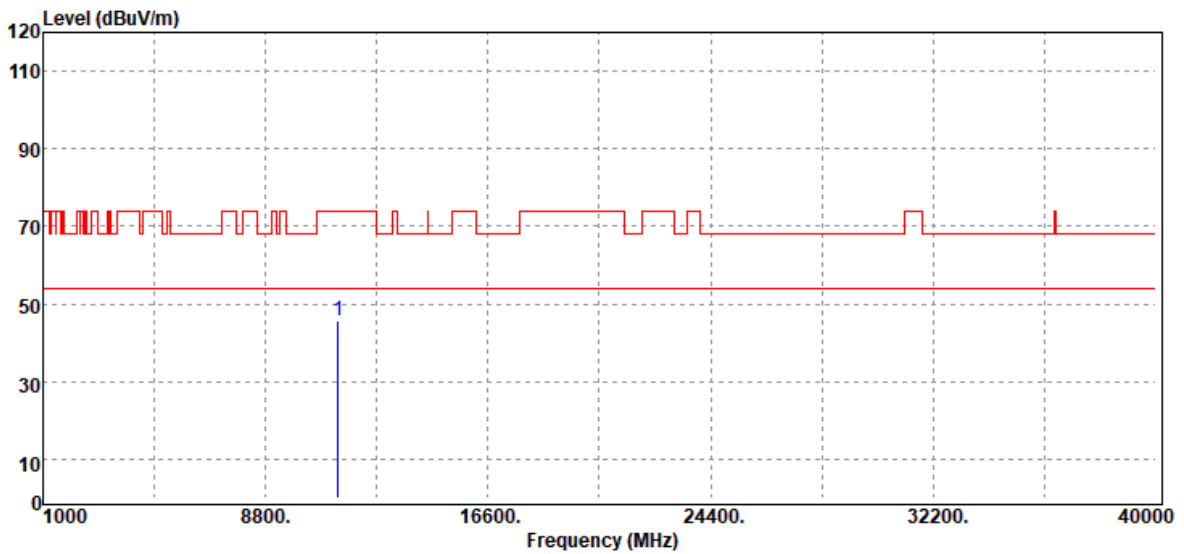

Freq. MHz	Detector Mode PK/QP/AV	Spectrum Reading Level dB μ V	Factor dB	Actual FS dB μ V/m	Limit @3m dB μ V/m	Margin dB
11340.00	Peak	42.79	2.92	45.71	74.00	-28.29
N/A						

Remark:

1. Measuring frequencies from 1 GHz to the 10th harmonic of highest fundamental frequency.
2. For above 1GHz, the EUT peak value was under average limit, therefore the Average value compliance with the average limit

Report No.: T201104D06-RP4

Test Mode	IEEE 802.11n 40 MHz / 5670 MHz	Temp/Hum	22.4(°C)/ 67%RH
Test Item	Harmonic	Test Date	November 19, 2020
Polarize	Horizontal	Test Engineer	Ray Li
Detector	Peak		

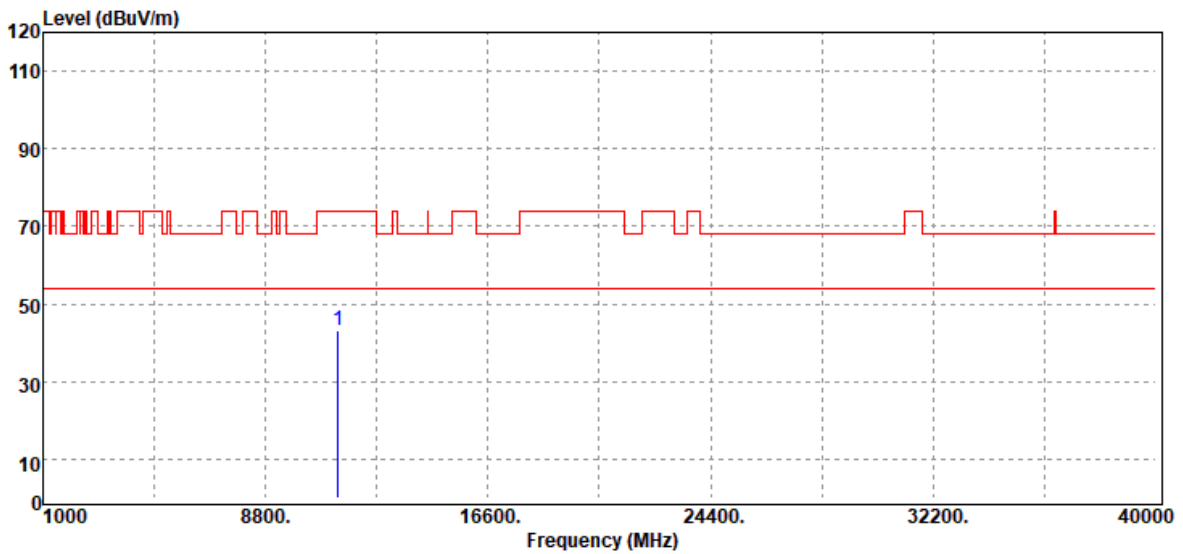

Freq. MHz	Detector Mode PK/QP/AV	Spectrum Reading Level dB μ V	Factor dB	Actual FS dB μ V/m	Limit @3m dB μ V/m	Margin dB
11340.00	Peak	40.39	2.92	43.31	74.00	-30.69
N/A						

Remark:

1. Measuring frequencies from 1 GHz to the 10th harmonic of highest fundamental frequency.
2. For above 1GHz, the EUT peak value was under average limit, therefore the Average value compliance with the average limit

Report No.: T201104D06-RP4

Test Mode	IEEE 802.11ac VHT80 / 5530 MHz	Temp/Hum	22.6(°C)/ 68%RH
Test Item	Harmonic	Test Date	November 20, 2020
Polarize	Vertical	Test Engineer	Ray Li
Detector	Peak		

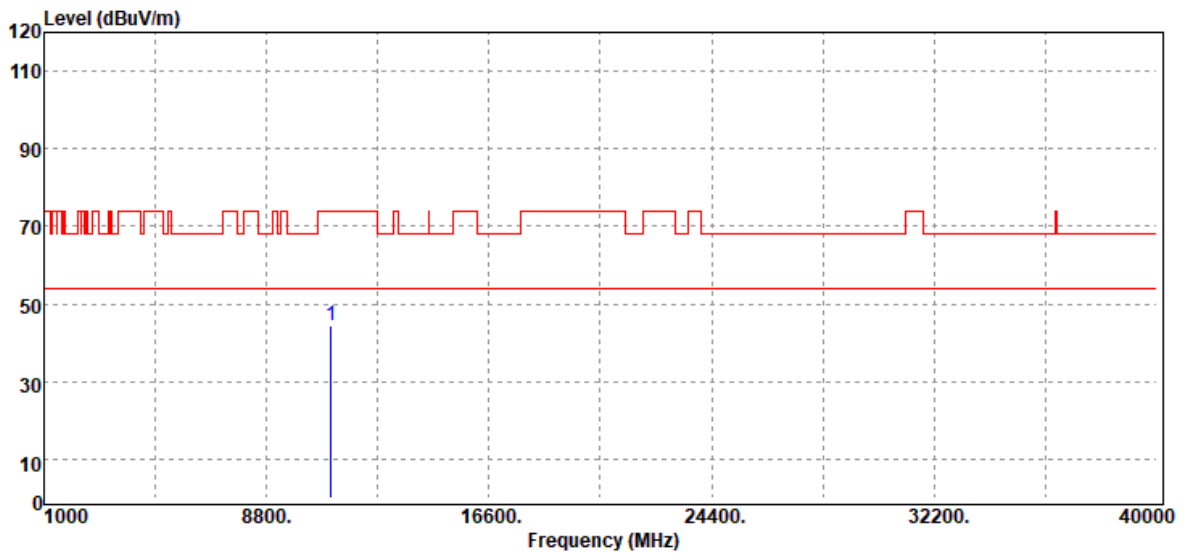

Freq. MHz	Detector Mode PK/QP/AV	Spectrum Reading Level dB μ V	Factor dB	Actual FS dB μ V/m	Limit @3m dB μ V/m	Margin dB
11060.00	Peak	41.43	3.09	44.52	74.00	-29.48
N/A						

Remark:

1. Measuring frequencies from 1 GHz to the 10th harmonic of highest fundamental frequency.
2. For above 1GHz, the EUT peak value was under average limit, therefore the Average value compliance with the average limit

Report No.: T201104D06-RP4

Test Mode	IEEE 802.11ac VHT80 / 5530 MHz	Temp/Hum	22.6(°C)/ 68%RH
Test Item	Harmonic	Test Date	November 20, 2020
Polarize	Horizontal	Test Engineer	Ray Li
Detector	Peak		

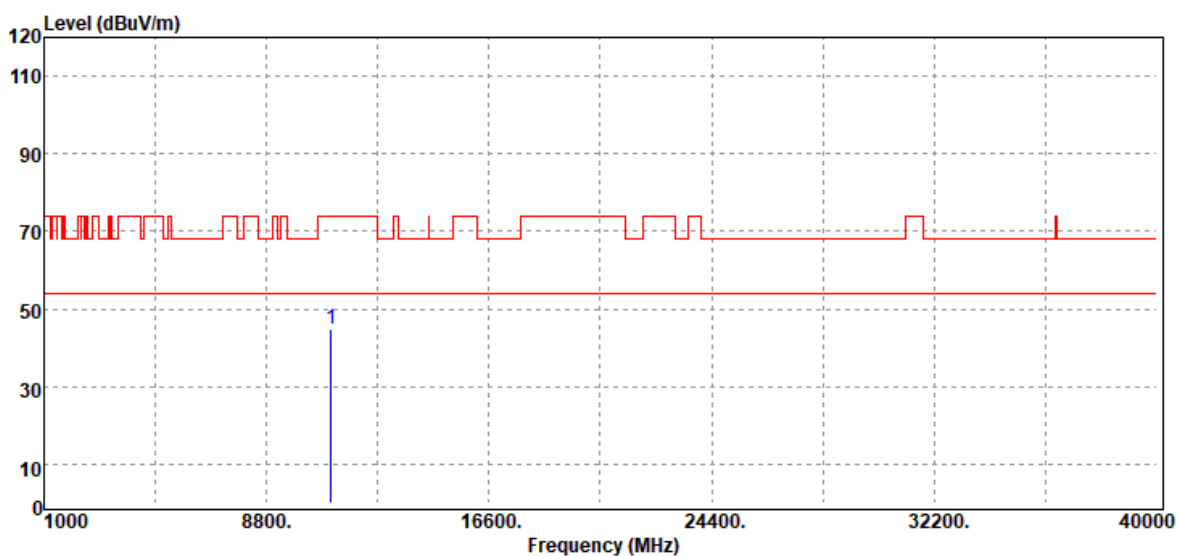

Freq. MHz	Detector Mode PK/QP/AV	Spectrum Reading Level dB μ V	Factor dB	Actual FS dB μ V/m	Limit @3m dB μ V/m	Margin dB
11060.00	Peak	41.85	3.09	44.94	74.00	-29.06
N/A						

Remark:

1. Measuring frequencies from 1 GHz to the 10th harmonic of highest fundamental frequency.
2. For above 1GHz, the EUT peak value was under average limit, therefore the Average value compliance with the average limit

Report No.: T201104D06-RP4

Test Data for UNII-3

Test Mode	IEEE 802.11a / 5745 MHz	Temp/Hum	22.4(°C)/ 67%RH
Test Item	Harmonic	Test Date	November 19, 2020
Polarize	Vertical	Test Engineer	Ray Li
Detector	Peak		

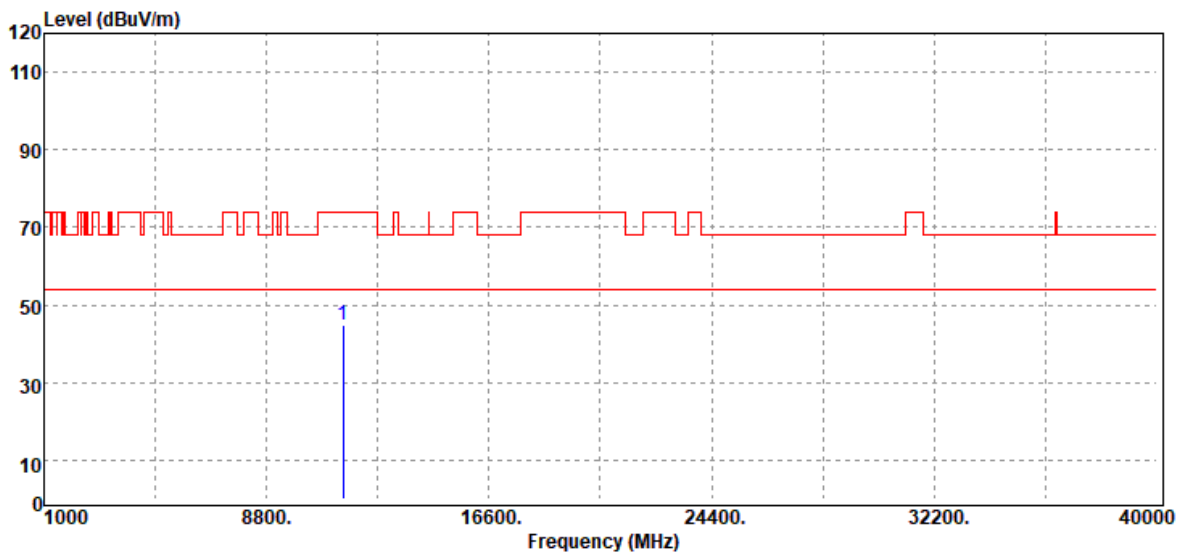

Freq. MHz	Detector Mode PK/QP/AV	Spectrum Reading Level dBµV	Factor dB	Actual FS dBµV/m	Limit @3m dBµV/m	Margin dB
11490.00	Peak	41.76	2.96	44.72	74.00	-29.28
N/A						

Remark:

1. Measuring frequencies from 1 GHz to the 10th harmonic of highest fundamental frequency.
2. For above 1GHz, the EUT peak value was under average limit, therefore the Average value compliance with the average limit

Report No.: T201104D06-RP4

Test Mode	IEEE 802.11a / 5745 MHz	Temp/Hum	22.4(°C)/ 67%RH
Test Item	Harmonic	Test Date	November 19, 2020
Polarize	Horizontal	Test Engineer	Ray Li
Detector	Peak		

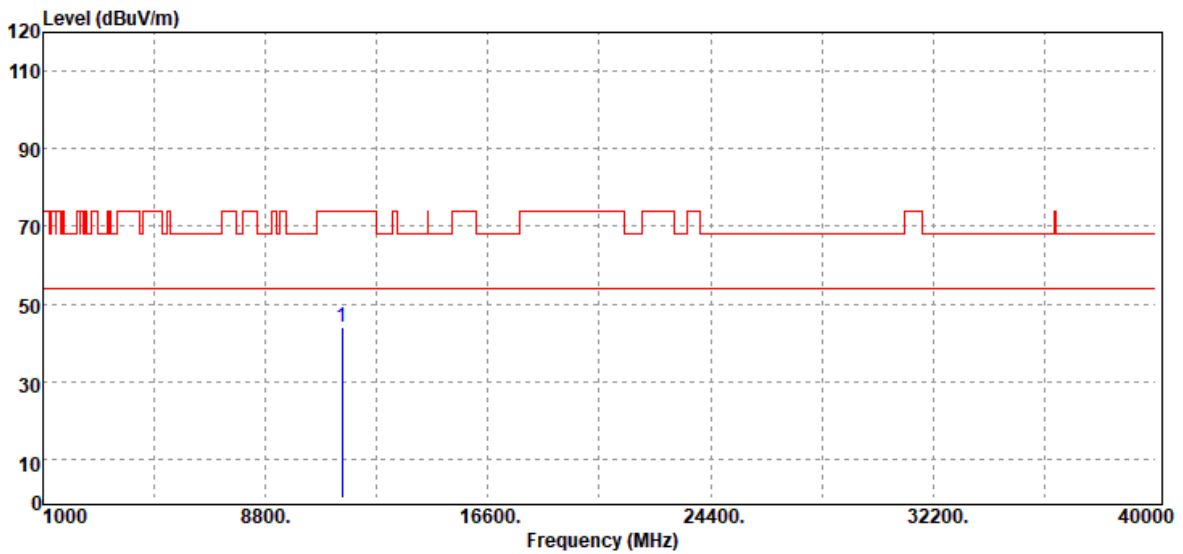

Freq. MHz	Detector Mode PK/QP/AV	Spectrum Reading Level dB μ V	Factor dB	Actual FS dB μ V/m	Limit @3m dB μ V/m	Margin dB
11490.00	Peak	41.10	2.96	44.06	74.00	-29.94
N/A						

Remark:

1. Measuring frequencies from 1 GHz to the 10th harmonic of highest fundamental frequency.
2. For above 1GHz, the EUT peak value was under average limit, therefore the Average value compliance with the average limit

Report No.: T201104D06-RP4

Test Mode	IEEE 802.11a / 5785 MHz	Temp/Hum	22.4(°C)/ 67%RH
Test Item	Harmonic	Test Date	November 19, 2020
Polarize	Vertical	Test Engineer	Ray Li
Detector	Peak		

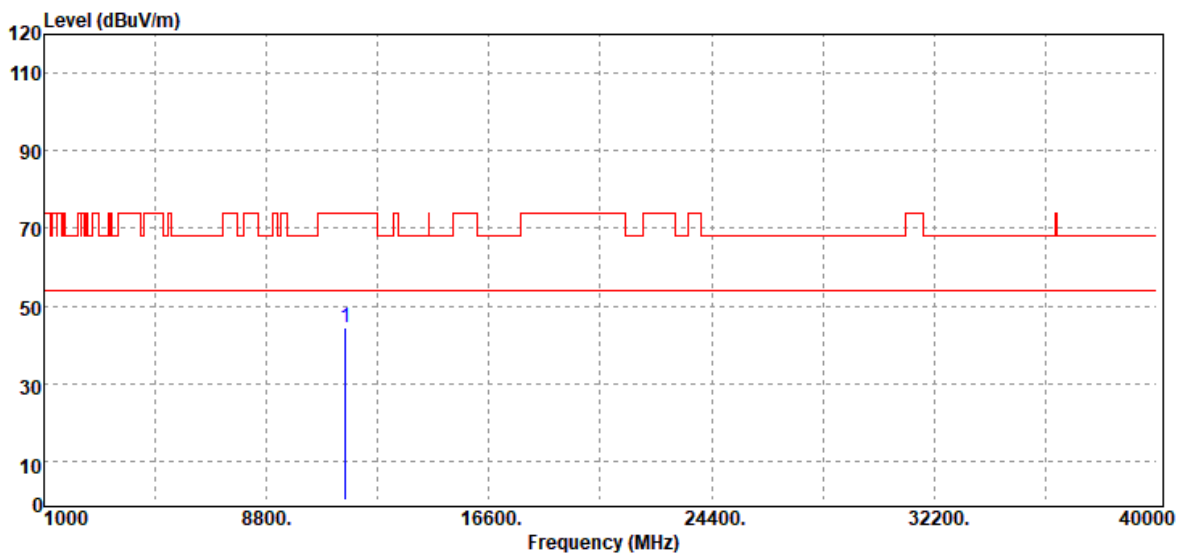

Freq. MHz	Detector Mode PK/QP/AV	Spectrum Reading Level dB μ V	Factor dB	Actual FS dB μ V/m	Limit @3m dB μ V/m	Margin dB
11570.00	Peak	41.75	2.76	44.51	74.00	-29.49
N/A						

Remark:

1. Measuring frequencies from 1 GHz to the 10th harmonic of highest fundamental frequency.
2. For above 1GHz, the EUT peak value was under average limit, therefore the Average value compliance with the average limit

Report No.: T201104D06-RP4

Test Mode	IEEE 802.11a / 5785 MHz	Temp/Hum	22.4(°C)/ 67%RH
Test Item	Harmonic	Test Date	November 19, 2020
Polarize	Horizontal	Test Engineer	Ray Li
Detector	Peak		

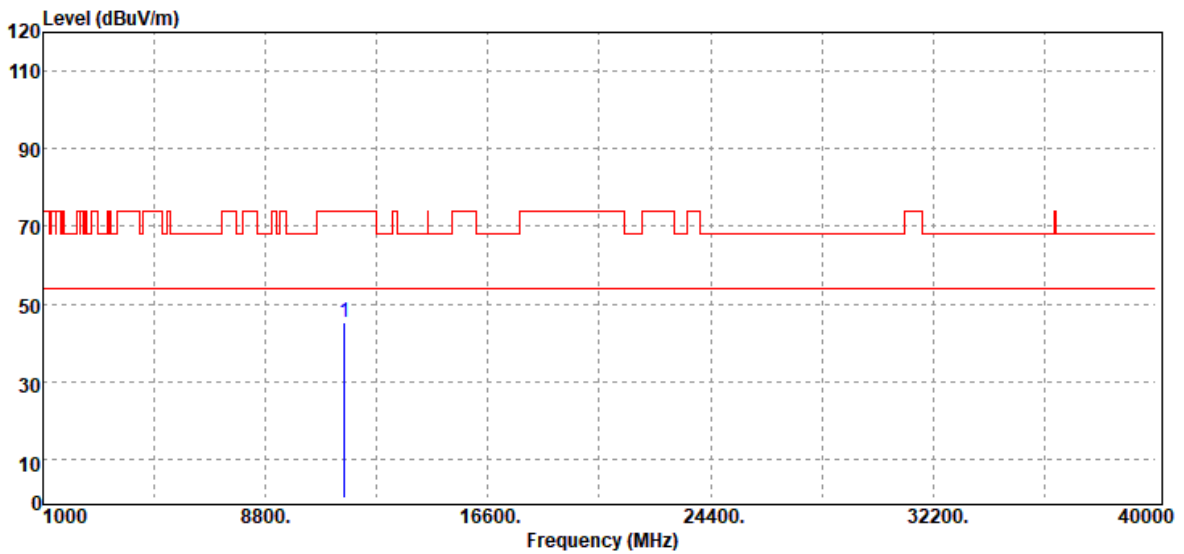

Freq. MHz	Detector Mode PK/QP/AV	Spectrum Reading Level dB μ V	Factor dB	Actual FS dB μ V/m	Limit @3m dB μ V/m	Margin dB
11570.00	Peak	42.39	2.76	45.15	74.00	-28.85
N/A						

Remark:

1. Measuring frequencies from 1 GHz to the 10th harmonic of highest fundamental frequency.
2. For above 1GHz, the EUT peak value was under average limit, therefore the Average value compliance with the average limit

Report No.: T201104D06-RP4

Test Mode	IEEE 802.11a / 5825 MHz	Temp/Hum	22.4(°C)/ 67%RH
Test Item	Harmonic	Test Date	November 19, 2020
Polarize	Vertical	Test Engineer	Ray Li
Detector	Peak		

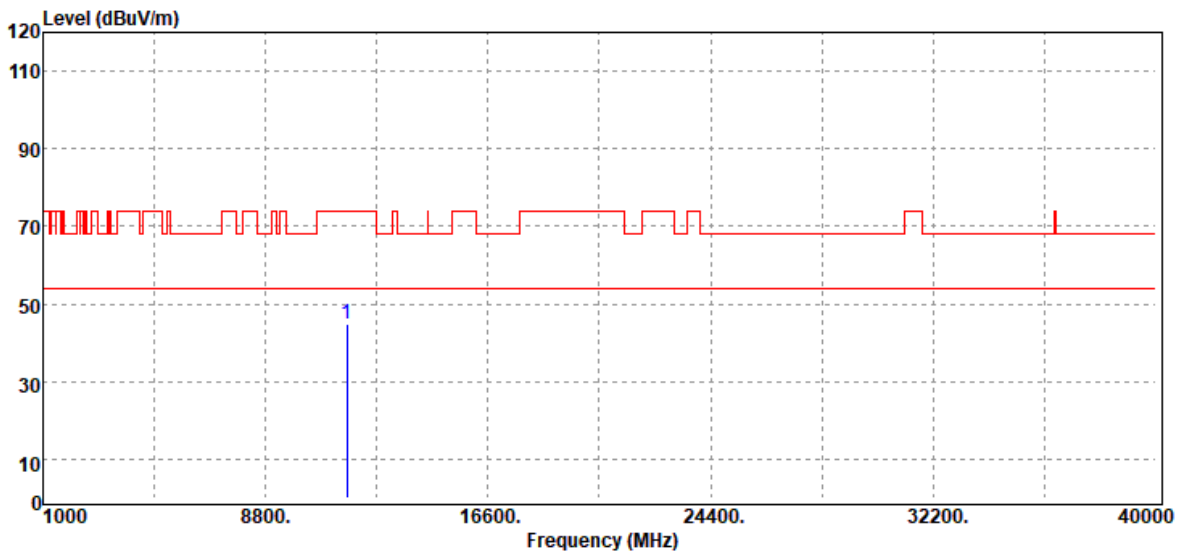

Freq. MHz	Detector Mode PK/QP/AV	Spectrum Reading Level dB μ V	Factor dB	Actual FS dB μ V/m	Limit @3m dB μ V/m	Margin dB
11650.00	Peak	41.83	2.83	44.66	74.00	-29.34
N/A						

Remark:

1. Measuring frequencies from 1 GHz to the 10th harmonic of highest fundamental frequency.
2. For above 1GHz, the EUT peak value was under average limit, therefore the Average value compliance with the average limit

Report No.: T201104D06-RP4

Test Mode	IEEE 802.11a / 5825 MHz	Temp/Hum	22.4(°C)/ 67%RH
Test Item	Harmonic	Test Date	November 19, 2020
Polarize	Horizontal	Test Engineer	Ray Li
Detector	Peak		



Freq. MHz	Detector Mode PK/QP/AV	Spectrum Reading Level dB μ V	Factor dB	Actual FS dB μ V/m	Limit @3m dB μ V/m	Margin dB
11650.00	Peak	41.97	2.83	44.80	74.00	-29.20
N/A						

Remark:

1. Measuring frequencies from 1 GHz to the 10th harmonic of highest fundamental frequency.
2. For above 1GHz, the EUT peak value was under average limit, therefore the Average value compliance with the average limit

Report No.: T201104D06-RP4

Test Mode	IEEE 802.11n 20 MHz / 5745 MHz	Temp/Hum	22.4(°C)/ 67%RH
Test Item	Harmonic	Test Date	November 19, 2020
Polarize	Vertical	Test Engineer	Ray Li
Detector	Peak		

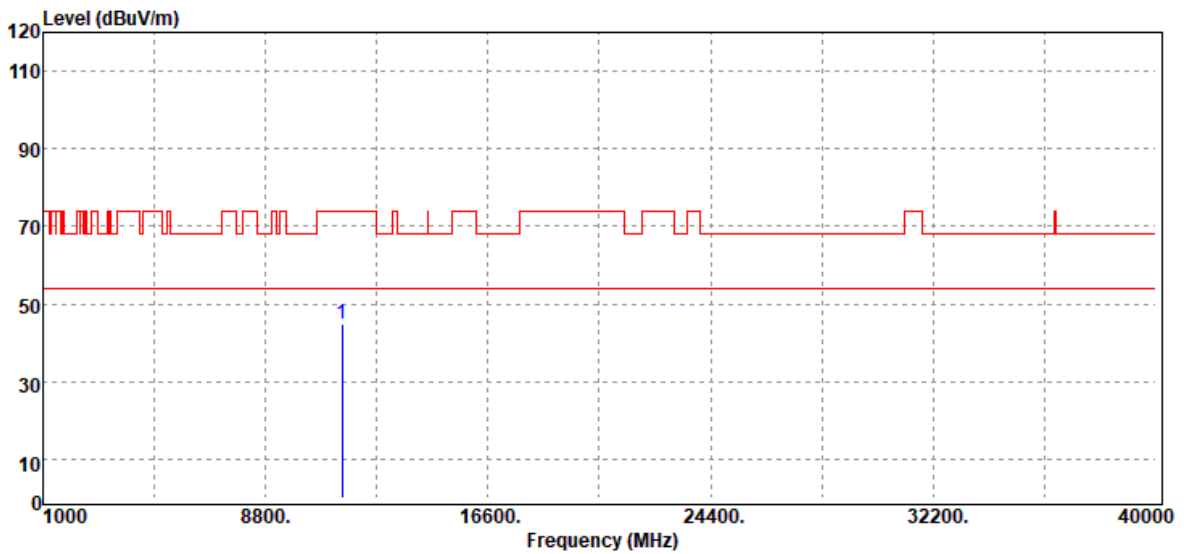

Freq. MHz	Detector Mode PK/QP/AV	Spectrum Reading Level dB μ V	Factor dB	Actual FS dB μ V/m	Limit @3m dB μ V/m	Margin dB
11490.00	Peak	41.97	2.96	44.93	74.00	-29.07
N/A						

Remark:

1. Measuring frequencies from 1 GHz to the 10th harmonic of highest fundamental frequency.
2. For above 1GHz, the EUT peak value was under average limit, therefore the Average value compliance with the average limit

Report No.: T201104D06-RP4

Test Mode	IEEE 802.11n 20 MHz / 5745 MHz	Temp/Hum	22.4(°C)/ 67%RH
Test Item	Harmonic	Test Date	November 19, 2020
Polarize	Horizontal	Test Engineer	Ray Li
Detector	Peak		

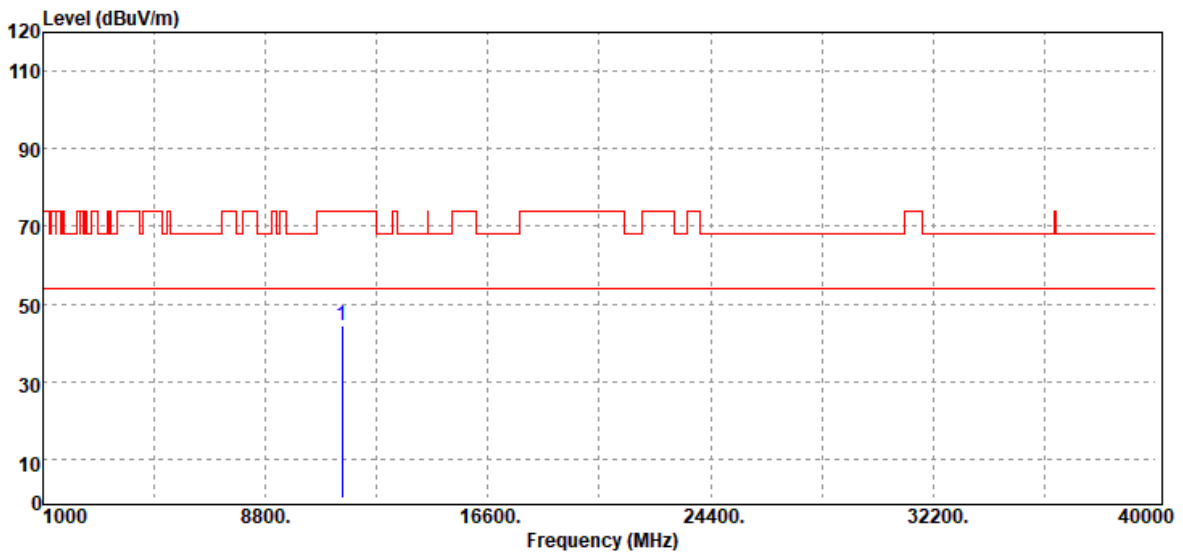

Freq. MHz	Detector Mode PK/QP/AV	Spectrum Reading Level dB μ V	Factor dB	Actual FS dB μ V/m	Limit @3m dB μ V/m	Margin dB
11490.00	Peak	41.36	2.96	44.32	74.00	-29.68
N/A						

Remark:

1. Measuring frequencies from 1 GHz to the 10th harmonic of highest fundamental frequency.
2. For above 1GHz, the EUT peak value was under average limit, therefore the Average value compliance with the average limit

Report No.: T201104D06-RP4

Test Mode	IEEE 802.11n 20 MHz/ 5785 MHz	Temp/Hum	22.4(°C)/ 67%RH
Test Item	Harmonic	Test Date	November 19, 2020
Polarize	Vertical	Test Engineer	Ray Li
Detector	Peak		



Freq. MHz	Detector Mode PK/QP/AV	Spectrum Reading Level dB μ V	Factor dB	Actual FS dB μ V/m	Limit @3m dB μ V/m	Margin dB
11570.00	Peak	42.39	2.76	45.15	74.00	-28.85
N/A						

Remark:

1. Measuring frequencies from 1 GHz to the 10th harmonic of highest fundamental frequency.
2. For above 1GHz, the EUT peak value was under average limit, therefore the Average value compliance with the average limit

Report No.: T201104D06-RP4

Test Mode	IEEE 802.11n 20 MHz/ 5785 MHz	Temp/Hum	22.4(°C)/ 67%RH
Test Item	Harmonic	Test Date	November 19, 2020
Polarize	Horizontal	Test Engineer	Ray Li
Detector	Peak		

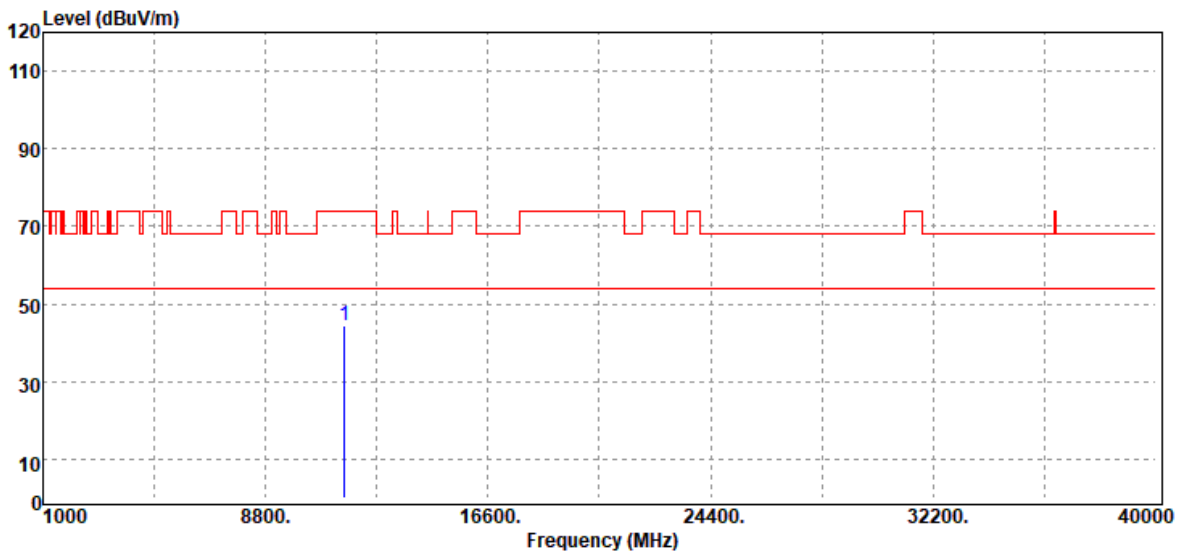

Freq. MHz	Detector Mode PK/QP/AV	Spectrum Reading Level dB μ V	Factor dB	Actual FS dB μ V/m	Limit @3m dB μ V/m	Margin dB
11570.00	Peak	41.77	2.76	44.53	74.00	-29.47
N/A						

Remark:

1. Measuring frequencies from 1 GHz to the 10th harmonic of highest fundamental frequency.
2. For above 1GHz, the EUT peak value was under average limit, therefore the Average value compliance with the average limit

Report No.: T201104D06-RP4

Test Mode	IEEE 802.11n 20 MHz/ 5825 MHz	Temp/Hum	22.4(°C)/ 67%RH
Test Item	Harmonic	Test Date	November 19, 2020
Polarize	Vertical	Test Engineer	Ray Li
Detector	Peak		

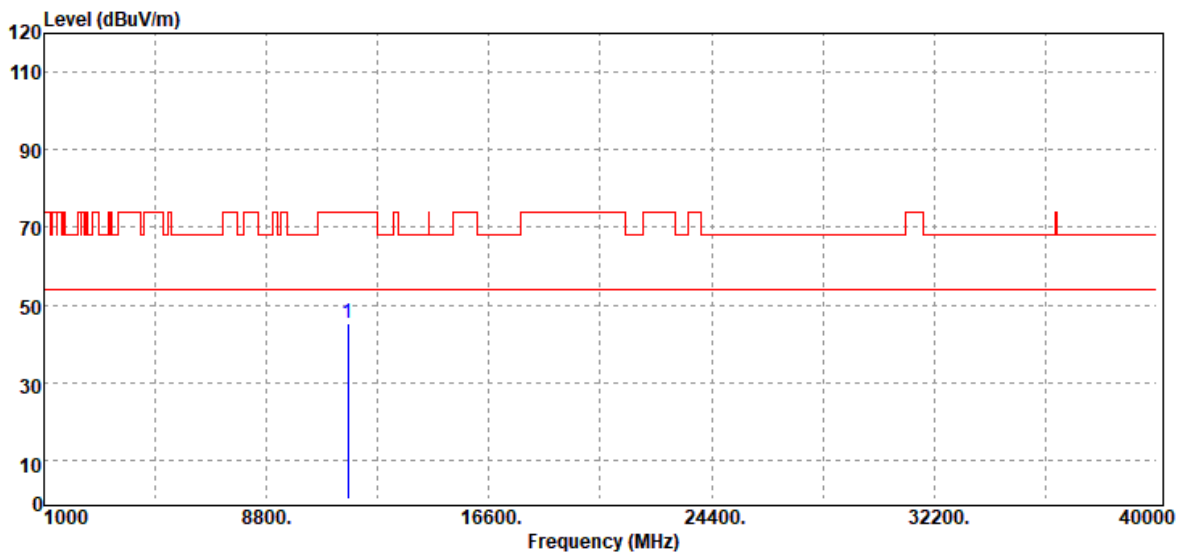

Freq. MHz	Detector Mode PK/QP/AV	Spectrum Reading Level dB μ V	Factor dB	Actual FS dB μ V/m	Limit @3m dB μ V/m	Margin dB
11650.00	Peak	42.27	2.83	45.10	74.00	-28.90
N/A						

Remark:

1. Measuring frequencies from 1 GHz to the 10th harmonic of highest fundamental frequency.
2. For above 1GHz, the EUT peak value was under average limit, therefore the Average value compliance with the average limit

Report No.: T201104D06-RP4

Test Mode	IEEE 802.11n 20 MHz/ 5825 MHz	Temp/Hum	22.4(°C)/ 67%RH
Test Item	Harmonic	Test Date	November 19, 2020
Polarize	Horizontal	Test Engineer	Ray Li
Detector	Peak		

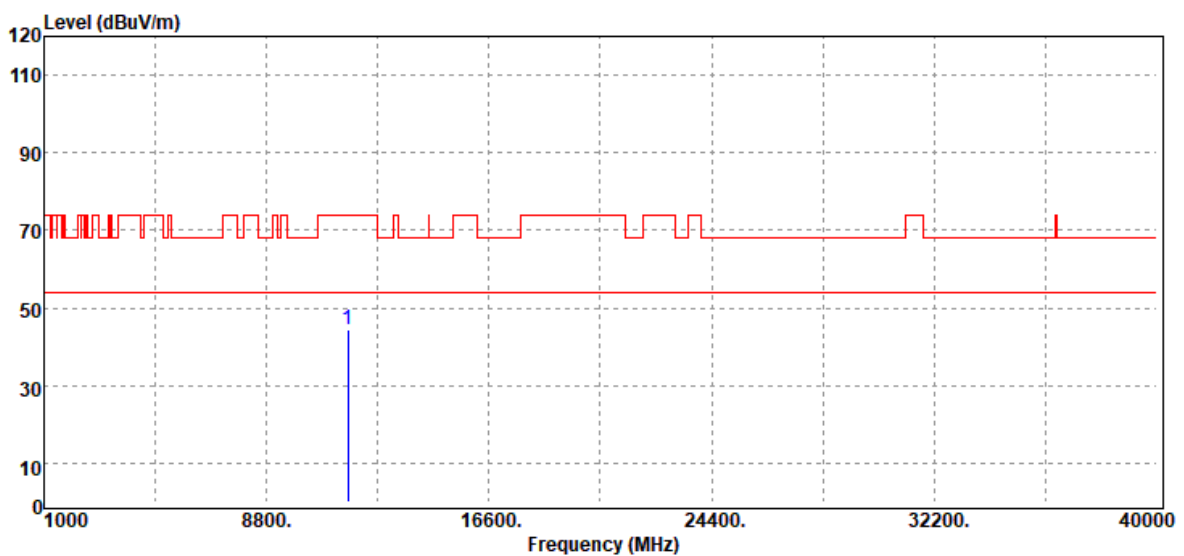

Freq. MHz	Detector Mode PK/QP/AV	Spectrum Reading Level dB μ V	Factor dB	Actual FS dB μ V/m	Limit @3m dB μ V/m	Margin dB
11650.00	Peak	41.70	2.83	44.53	74.00	-29.47
N/A						

Remark:

1. Measuring frequencies from 1 GHz to the 10th harmonic of highest fundamental frequency.
2. For above 1GHz, the EUT peak value was under average limit, therefore the Average value compliance with the average limit

Report No.: T201104D06-RP4

Test Mode	IEEE 802.11n 40 MHz/ 5755 MHz	Temp/Hum	22.6(°C)/ 68%RH
Test Item	Harmonic	Test Date	November 20, 2020
Polarize	Vertical	Test Engineer	Ray Li
Detector	Peak		



Freq. MHz	Detector Mode PK/QP/AV	Spectrum Reading Level dBμV	Factor dB	Actual FS dBμV/m	Limit @3m dBμV/m	Margin dB
11510.00	Peak	40.34	2.91	43.25	74.00	-30.75
N/A						

Remark:

1. Measuring frequencies from 1 GHz to the 10th harmonic of highest fundamental frequency.
2. For above 1GHz, the EUT peak value was under average limit, therefore the Average value compliance with the average limit

Report No.: T201104D06-RP4

Test Mode	IEEE 802.11n 40 MHz/ 5755 MHz	Temp/Hum	22.6(°C)/ 68%RH
Test Item	Harmonic	Test Date	November 20, 2020
Polarize	Horizontal	Test Engineer	Ray Li
Detector	Peak		

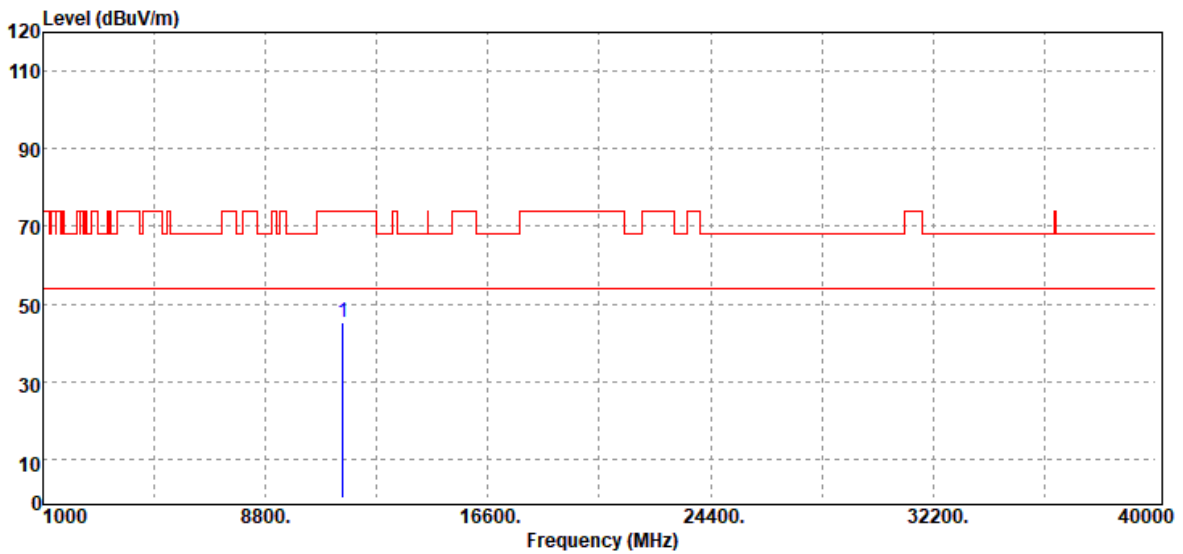

Freq. MHz	Detector Mode PK/QP/AV	Spectrum Reading Level dB μ V	Factor dB	Actual FS dB μ V/m	Limit @3m dB μ V/m	Margin dB
11510.00	Peak	42.20	2.91	45.11	74.00	-28.89
N/A						

Remark:

1. Measuring frequencies from 1 GHz to the 10th harmonic of highest fundamental frequency.
2. For above 1GHz, the EUT peak value was under average limit, therefore the Average value compliance with the average limit

Report No.: T201104D06-RP4

Test Mode	IEEE 802.11n 40 MHz/ 5795 MHz	Temp/Hum	22.6(°C)/ 68%RH
Test Item	Harmonic	Test Date	November 20, 2020
Polarize	Vertical	Test Engineer	Ray Li
Detector	Peak		



Freq. MHz	Detector Mode PK/QP/AV	Spectrum Reading Level dB μ V	Factor dB	Actual FS dB μ V/m	Limit @3m dB μ V/m	Margin dB
11590.00	Peak	41.56	2.79	44.35	74.00	-29.65
N/A						

Remark:

1. Measuring frequencies from 1 GHz to the 10th harmonic of highest fundamental frequency.
2. For above 1GHz, the EUT peak value was under average limit, therefore the Average value compliance with the average limit

Report No.: T201104D06-RP4

Test Mode	IEEE 802.11n 40 MHz/ 5795 MHz	Temp/Hum	22.6(°C)/ 68%RH
Test Item	Harmonic	Test Date	November 20, 2020
Polarize	Horizontal	Test Engineer	Ray Li
Detector	Peak		



Freq. MHz	Detector Mode PK/QP/AV	Spectrum Reading Level dB μ V	Factor dB	Actual FS dB μ V/m	Limit @3m dB μ V/m	Margin dB
11590.00	Peak	42.09	2.79	44.88	74.00	-29.12
N/A						

Remark:

1. Measuring frequencies from 1 GHz to the 10th harmonic of highest fundamental frequency.
2. For above 1GHz, the EUT peak value was under average limit, therefore the Average value compliance with the average limit

Report No.: T201104D06-RP4

Test Mode	IEEE 802.11ac VHT80/ 5775 MHz	Temp/Hum	22.6(°C)/ 68%RH
Test Item	Harmonic	Test Date	November 20, 2020
Polarize	Vertical	Test Engineer	Ray Li
Detector	Peak		

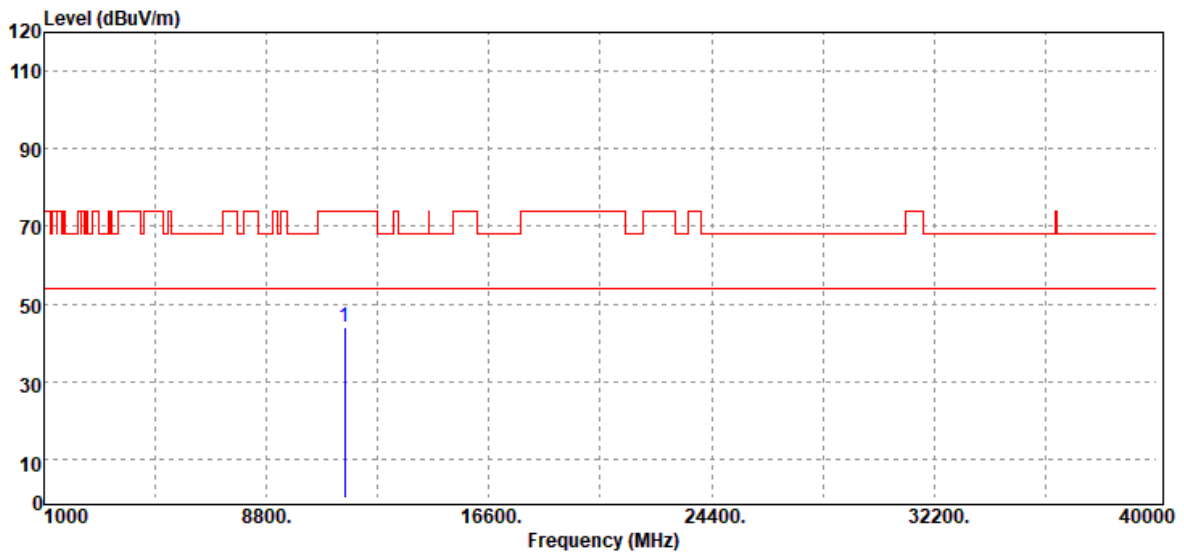

Freq. MHz	Detector Mode PK/QP/AV	Spectrum Reading Level dB μ V	Factor dB	Actual FS dB μ V/m	Limit @3m dB μ V/m	Margin dB
11550.00	Peak	41.15	2.72	43.87	74.00	-30.13
N/A						

Remark:

1. Measuring frequencies from 1 GHz to the 10th harmonic of highest fundamental frequency.
2. For above 1GHz, the EUT peak value was under average limit, therefore the Average value compliance with the average limit

Report No.: T201104D06-RP4

Test Mode	IEEE 802.11ac VHT80/ 5775 MHz	Temp/Hum	22.6(°C)/ 68%RH
Test Item	Harmonic	Test Date	November 20, 2020
Polarize	Horizontal	Test Engineer	Ray Li
Detector	Peak		

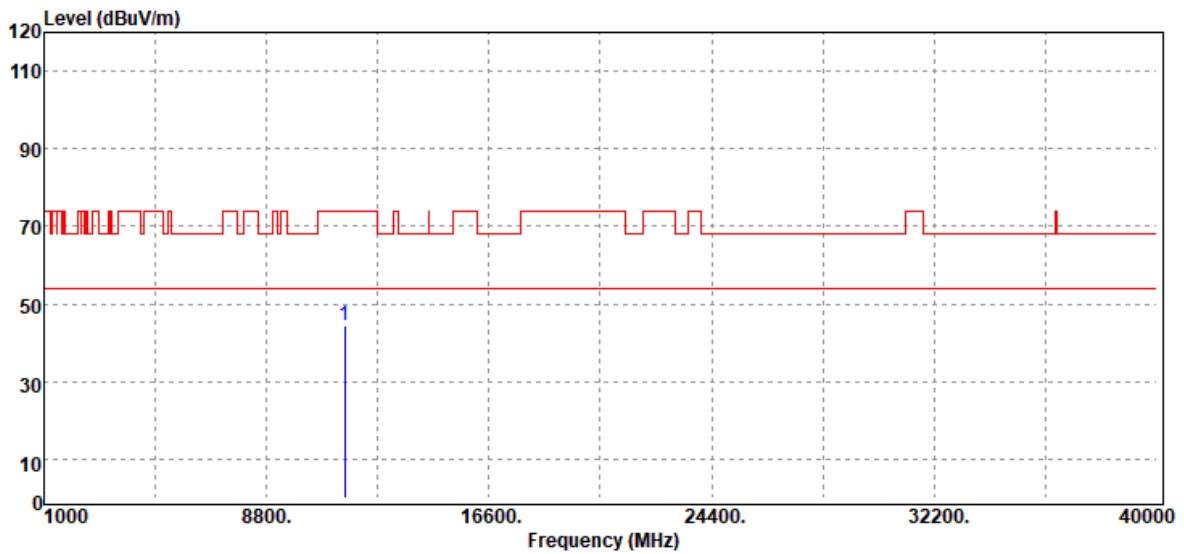

Freq. MHz	Detector Mode PK/QP/AV	Spectrum Reading Level dB μ V	Factor dB	Actual FS dB μ V/m	Limit @3m dB μ V/m	Margin dB
11550.00	Peak	41.58	2.72	44.30	74.00	-29.70
N/A						

Remark:

1. Measuring frequencies from 1 GHz to the 10th harmonic of highest fundamental frequency.
2. For above 1GHz, the EUT peak value was under average limit, therefore the Average value compliance with the average limit

4.6 FREQUENCY STABILITY

4.6.1 Test Limit

According to §15.407(g) manufacturers of U-NII devices are responsible for ensuring frequency stability such that an emission is maintained within the band of operation under all conditions of normal operation as specified in the operational description.

4.6.2 Test Procedure

The equipment under test was connected to an external AC or DC power supply and input rated voltage. RF output was connected to a frequency counter or spectrum analyzer via feed through attenuators. The EUT was placed inside the temperature chamber. Set the spectrum analyzer RBW low enough to obtain the desired frequency resolution and measure EUT 20°C operating frequency as reference frequency. Turn EUT off and set the chamber temperature to -35°C. After the temperature stabilized for approximately 30 minutes recorded the frequency. Repeat step measure with 10°C increased per stage until the highest temperature of +65°C reached.

4.6.3 Test Setup

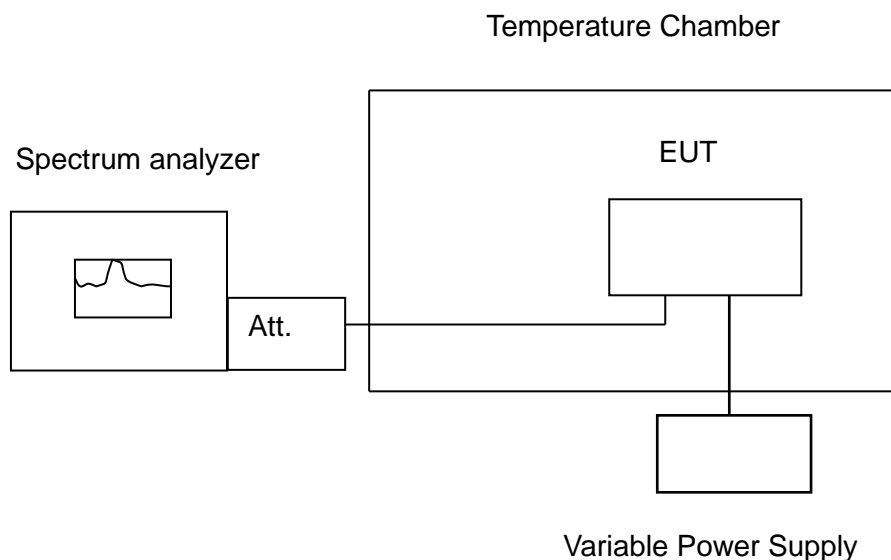

Report No.: T201104D06-RP4

4.6.4 Test Result

Temperature: 25.6°C

Humidity: 54% RH

Tested by: Rick Lee

Test date: November 30, 2020

Temp. (°C)	Voltage (V)	Measured Frequency	5180				Limit				Result
			Time (min)				20ppm				
Extreme Temperatures		0 min	2 min	5 min	10 min	0 min	2 min	5 min	10 min		
85	5	5179.99999	5179.99999	5179.99999	5179.99999	0.0000	0.0000	0.0000	0.0000	Pass	
70	5	5179.99999	5179.99999	5179.99999	5179.99999	0.0000	0.0000	0.0000	0.0000	Pass	
60	5	5179.99999	5179.99999	5179.99999	5179.99999	0.0000	0.0000	0.0000	0.0000	Pass	
50	5	5179.99999	5179.99999	5179.99999	5179.99999	0.0000	0.0000	0.0000	0.0000	Pass	
40	5	5179.99999	5179.99999	5179.99999	5179.99999	0.0000	0.0000	0.0000	0.0000	Pass	
30	5	5179.99999	5179.99999	5179.99999	5179.99999	0.0000	0.0000	0.0000	0.0000	Pass	
25	5	5179.99999	5179.99999	5179.99999	5179.99999	0.0000	0.0000	0.0000	0.0000	Pass	
10	5	5179.99999	5179.99999	5179.99999	5179.99999	0.0000	0.0000	0.0000	0.0000	Pass	
0	5	5179.99999	5179.99999	5179.99999	5179.99999	0.0000	0.0000	0.0000	0.0000	Pass	
-10	5	5179.99999	5179.99999	5179.99999	5179.99999	0.0000	0.0000	0.0000	0.0000	Pass	
-20	5	5179.99999	5179.99999	5179.99999	5179.99999	0.0000	0.0000	0.0000	0.0000	Pass	
-30	5	5179.99999	5179.99999	5179.99999	5179.99999	0.0000	0.0000	0.0000	0.0000	Pass	
Extreme Voltage											
25	4.5	5179.99999	5179.99999	5179.99999	5179.99999	0.0000	0.0000	0.0000	0.0000	Pass	
25	5.5	5179.99999	5179.99999	5179.99999	5179.99999	0.0000	0.0000	0.0000	0.0000	Pass	

Temp. (°C)	Voltage (V)	Measured Frequency	5260				Limit				Result
			Time (min)				20ppm				
Extreme Temperatures		0 min	2 min	5 min	10 min	0 min	2 min	5 min	10 min		
85	5	5259.98000	5259.98000	5259.98000	5259.98000	0.0000	0.0000	0.0000	0.0000	Pass	
70	5	5259.98000	5259.98000	5259.98000	5259.98000	0.0000	0.0000	0.0000	0.0000	Pass	
60	5	5259.98000	5259.98000	5259.98000	5259.98000	0.0000	0.0000	0.0000	0.0000	Pass	
50	5	5259.98000	5259.98000	5259.98000	5259.98000	0.0000	0.0000	0.0000	0.0000	Pass	
40	5	5259.98000	5259.98000	5259.98000	5259.98000	0.0000	0.0000	0.0000	0.0000	Pass	
30	5	5259.98000	5259.98000	5259.98000	5259.98000	0.0000	0.0000	0.0000	0.0000	Pass	
25	5	5259.98000	5259.98000	5259.98000	5259.98000	0.0000	0.0000	0.0000	0.0000	Pass	
10	5	5259.98000	5259.98000	5259.98000	5259.98000	0.0000	0.0000	0.0000	0.0000	Pass	
0	5	5259.98000	5259.98000	5259.98000	5259.98000	0.0000	0.0000	0.0000	0.0000	Pass	
-10	5	5259.98000	5259.98000	5259.98000	5259.98000	0.0000	0.0000	0.0000	0.0000	Pass	
-20	5	5259.98000	5259.98000	5259.98000	5259.98000	0.0000	0.0000	0.0000	0.0000	Pass	
Extreme Voltage											
25	4.5	5259.98000	5259.98000	5259.98000	5259.98000	0.0000	0.0000	0.0000	0.0000	Pass	
25	5.5	5259.98000	5259.98000	5259.98000	5259.98000	0.0000	0.0000	0.0000	0.0000	Pass	

Report No.: T201104D06-RP4

Temp. (°C)	Voltage (V)	Measured Frequency	5500				Limit				Result
			Time (min)				20ppm				
Extreme Temperatures		0 min	2 min	5 min	10 min	0 min	2 min	5 min	10 min		
85	5	5499.98000	5499.98000	5499.98000	5499.98000	0.0000	0.0000	0.0000	0.0000	Pass	
70	5	5499.98000	5499.98000	5499.98000	5499.98000	0.0000	0.0000	0.0000	0.0000	Pass	
60	5	5499.98000	5499.98000	5499.98000	5499.98000	0.0000	0.0000	0.0000	0.0000	Pass	
50	5	5499.98000	5499.98000	5499.98000	5499.98000	0.0000	0.0000	0.0000	0.0000	Pass	
40	5	5499.98000	5499.98000	5499.98000	5499.98000	0.0000	0.0000	0.0000	0.0000	Pass	
30	5	5499.98000	5499.98000	5499.98000	5499.98000	0.0000	0.0000	0.0000	0.0000	Pass	
25	5	5499.98000	5499.98000	5499.98000	5499.98000	0.0000	0.0000	0.0000	0.0000	Pass	
10	5	5499.98000	5499.98000	5499.98000	5499.98000	0.0000	0.0000	0.0000	0.0000	Pass	
0	5	5499.98000	5499.98000	5499.98000	5499.98000	0.0000	0.0000	0.0000	0.0000	Pass	
-10	5	5499.98000	5499.98000	5499.98000	5499.98000	0.0000	0.0000	0.0000	0.0000	Pass	
-20	5	5499.98000	5499.98000	5499.98000	5499.98000	0.0000	0.0000	0.0000	0.0000	Pass	
Extreme Voltage											
25	4.5	5499.98000	5499.98000	5499.98000	5499.98000	0.0000	0.0000	0.0000	0.0000	Pass	
25	5.5	5499.98000	5499.98000	5499.98000	5499.98000	0.0000	0.0000	0.0000	0.0000	Pass	

Temp. (°C)	Voltage (V)	Measured Frequency	5745				Limit				Result
			Time (min)				20ppm				
Extreme Temperatures		0 min	2 min	5 min	10 min	0 min	2 min	5 min	10 min		
85	5	5744.98000	5744.98000	5744.98000	5744.98000	0.0000	0.0000	0.0000	0.0000	Pass	
70	5	5744.98000	5744.98000	5744.98000	5744.98000	0.0000	0.0000	0.0000	0.0000	Pass	
60	5	5744.98000	5744.98000	5744.98000	5744.98000	0.0000	0.0000	0.0000	0.0000	Pass	
50	5	5744.98000	5744.98000	5744.98000	5744.98000	0.0000	0.0000	0.0000	0.0000	Pass	
40	5	5744.98000	5744.98000	5744.98000	5744.98000	0.0000	0.0000	0.0000	0.0000	Pass	
30	5	5744.98000	5744.98000	5744.98000	5744.98000	0.0000	0.0000	0.0000	0.0000	Pass	
25	5	5744.98000	5744.98000	5744.98000	5744.98000	0.0000	0.0000	0.0000	0.0000	Pass	
10	5	5744.98000	5744.98000	5744.98000	5744.98000	0.0000	0.0000	0.0000	0.0000	Pass	
0	5	5744.98000	5744.98000	5744.98000	5744.98000	0.0000	0.0000	0.0000	0.0000	Pass	
-10	5	5744.98000	5744.98000	5744.98000	5744.98000	0.0000	0.0000	0.0000	0.0000	Pass	
-20	5	5744.98000	5744.98000	5744.98000	5744.98000	0.0000	0.0000	0.0000	0.0000	Pass	
Extreme Voltage											
25	4.5	5744.98000	5744.98000	5744.98000	5744.98000	0.0000	0.0000	0.0000	0.0000	Pass	
25	5.5	5744.98000	5744.98000	5744.98000	5744.98000	0.0000	0.0000	0.0000	0.0000	Pass	

4.7 DYNAMIC FREQUENCY SELECTION

4.7.1 Test Limit

FCC according to §15.407 (h), KDB 905462 D02 "compliance measurement procedures for unlicensed-national information infrastructure devices operating in the 5250-5350 MHz and 5470-5725 MHz bands incorporating dynamic frequency selection". and KDB 905462 D03 " U-NII client devices without radar detection capability.

IC according RSS-247 section 6.3, and it harmonized with FCC Part 15 DFS rules.

The EIRP refer section 4.3 output power measurement in this report.

Table 1: Applicability of DFS requirements prior to use of a channel

Requirement	Operational Mode		
	Master	Client (without radar detection)	Client(with radar detection)
Non-Occupancy Period	Yes	Not required	Yes
DFS Detection Threshold	Yes	Not required	Yes
Channel Availability Check Time	Yes	Not required	Not required
U-NII Detection Bandwidth	Yes	Not required	Yes

Table 2: Applicability of DFS requirements during normal operation

Requirement	Operational Mode	
	Master Device or Client with Radar Detection	Client Without Radar Detection
DFS Detection Threshold	Yes	Not required
Channel Closing Transmission Time	Yes	Yes
Channel Move Time	Yes	Yes
U-NII Detection Bandwidth	Yes	Not required

Additional requirements for devices with multiple bandwidth mods	Master Device or Client with Radar Detection	Client Without Radar Detection
U-NII Detection Bandwidth and Statistical Performance Check	All BW modes must be tested	Not required
Channel Move Time and Channel Closing Transmission Time	Test using widest BW mode available	Test using the widest BW mode available for the link
All other tests	Any single BW mode	Not required

Note: Frequencies selected for statistical performance check (Section 7.8.4) should include several frequencies within the radar detection bandwidth and frequencies near the edge of the radar detection bandwidth. For 802.11 devices it is suggested to select frequencies in each of the bonded 20 MHz channels and the channel center frequency.

Report No.: T201104D06-RP4

Table 3: Interference Threshold values, Master or Client incorporating In-Service

Maximum Transmit Power	Value (See Notes 1, 2, and 3)
EIRP \geq 200 milliwatt	-64 dBm
EIRP < 200 milliwatt and power spectral density < 10 dBm/MHz	-62 dBm
EIRP < 200 milliwatt that do not meet the power spectral density requirement	-64 dBm

Note 1: This is the level at the input of the receiver assuming a 0 dBi receive antenna.

Note 2: Throughout these test procedures an additional 1 dB has been added to the amplitude of the test transmission waveforms to account for variations in measurement equipment. This will ensure that the test signal is at or above the detection threshold level to trigger a DFS response.

Note 3: EIRP is based on the highest antenna gain. For MIMO devices refer to KDB Publication 662911 D01.

Table 4: DFS Response requirement values

Parameter	Value
Non-occupancy period	Minimum 30 minutes
Channel Availability Check Time	60 seconds
Channel Move Time	10 seconds See Note 1.
Channel Closing Transmission Time	200 milliseconds + an aggregate of 60 milliseconds over remaining 10 second period. See Notes 1 and 2.
U-NII Detection Bandwidth	Minimum 100% of the U-NII 99% transmission power bandwidth. See Note 3.

Note 1: Channel Move Time and the Channel Closing Transmission Time should be performed with Radar Type 0. The measurement timing begins at the end of the Radar Type 0 burst.

Note 2: The Channel Closing Transmission Time is comprised of 200 milliseconds starting at the beginning of the Channel Move Time plus any additional intermittent control signals required to facilitate a Channel move (an aggregate of 60 milliseconds) during the remainder of the 10 second period. The aggregate duration of control signals will not count quiet periods in between transmissions.

Note 3: During the U-NII Detection Bandwidth detection test, radar type 0 should be used. For each frequency step the minimum percentage of detection is 90 percent. Measurements are performed with no data traffic.

Table 5 – Short Pulse Radar Test Waveforms

Radar Type	Pulse Width (µsec)	PRI (µsec)	Number of Pulses	Minimum Percentage of Successful Detection	Minimum Number of Trials
0	1	1428	18	See Note 1	
1	1	Test A: 15 unique PRI values randomly selected from the list of 23 PRI values in Table 5a	$\text{Roundup} \left\{ \left(\frac{1}{360} \right) \cdot \left(\frac{19 \cdot 10^6}{\text{PRI}_{\mu\text{sec}}} \right) \right\}$	60%	30
		Test B: 15 unique PRI values randomly selected within the range of 518-3066 µsec, with a minimum increment of 1 µsec, excluding PRI values selected in Test A			
2	1-5	150-230	23-29	60%	30
3	6-10	200-500	16-18	60%	30
4	11-20	200-500	12-16	60%	30
Aggregate (Radar Types 1-4)				80%	120
Note 1: Short Pulse Radar Type 0 should be used for the detection bandwidth test, channel move time, and channel closing time tests.					

Report No.: T201104D06-RP4

Table 6 – Long Pulse Radar Test Signal

Radar Type	Pulse Width (µsec)	Chirp Width (MHz)	PRI (µsec)	Number of Pulses per Burst	Number of Bursts	Minimum Percentage of Successful Detection	Minimum Number of Trials
5	50-100	5-20	1000-2000	1-3	8-20	80%	30

Table 7 – Frequency Hopping Radar Test Signal

Radar Type	Pulse Width (µsec)	PRI (µsec)	Pulses per Hop	Hopping Rate (kHz)	Hopping Sequence Length (msec)	Minimum Percentage of Successful Detection	Minimum Number of Trials
6	1	333	9	0.333	300	70%	30

4.7.2 Test Procedure

Overview Of EUT With Respect To §15.407 (H) Requirements

The firmware installed in the EUT during testing was:

Firmware Rev: 0.0.35.2_20171101.100446

The EUT operates over the 5250-5350 MHz range as a Client Device that does not have radar detection capability.

The EUT uses one transmitter connected to two 50-ohm coaxial antenna ports via a diversity switch. Only one antenna port is connected to the test system since the EUT has one antenna only.

The Slave device associated with the EUT during these tests does not have radar detection capability.

WLAN traffic is generated by streaming the video file TestFile.mp2 “6 ½ Magic Hours” from the Master to the Slave in full motion video mode using the media player with the V2.61 Codec package.

The EUT utilizes the 802.11a architecture, with a nominal channel bandwidth of 20 MHz.

The rated output power of the Master unit is < 23dBm (EIRP). Therefore the required interference threshold level is -62 dBm. After correction for antenna gain and procedural adjustments, the required conducted threshold at the antenna port is $-62 + 5 = -57$ dBm.

The calibrated conducted DFS Detection Threshold level is set to -57 dBm. The tested level is lower than the required level hence it provides margin to the limit.

Manufacturer’s Statement Regarding Uniform Channel Spreading

The end product implements an automatic channel selection feature at startup such that operation commences on channels distributed across the entire set of allowed 5GHz channels. This feature will ensure uniform spreading is achieved while avoiding non-allowed channels due to prior radar events.

TEST AND MEASUREMENT SYSTEM

System Overview

The measurement system is based on a conducted test method.

The short pulse and long pulse signal generating system utilizes the NTIA software. The Vector Signal Generator has been validated by the NTIA. The hopping signal generating system utilizes the CCS simulated hopping method and system, which has been validated by the DoD, FCC and NTIA. The software selects waveform parameters from within the bounds of the signal type on a random basis using uniform distribution.

The short pulse types 2, 3 and 4, and the long pulse type 5 parameters are randomized at run-time.

The hopping type 6 pulse parameters are fixed while the hopping sequence is based on the August 2005 NTIA Hopping Frequency List. The initial starting point randomized at run-time and each subsequent starting point is incremented by 475. Each frequency in the 100-length segment is compared to the boundaries of the EUT Detection Bandwidth and the software creates a hopping burst pattern in accordance with Section 7.4.1.3 Method #2 Simulated Frequency Hopping Radar Waveform Generating Subsystem of FCC 06-96 APPENDIX. The frequency of the signal generator is incremented in 1 MHz steps from FL to FH for each successive trial. This incremental sequence is repeated as required to generate a minimum of 30 total trials and to maintain a uniform frequency distribution over the entire Detection Bandwidth.

The signal monitoring equipment consists of a spectrum analyzer set to display 8001 bins on the horizontal axis. The time-domain resolution is 2 msec / bin with a 16 second sweep time, meeting the 10 second short pulse reporting criteria. The aggregate ON time is calculated by multiplying the number of bins above a threshold during a particular observation period by the dwell time per bin, with the analyzer set to peak detection and max hold. The time-domain resolution is 3 msec / bin with a 24 second sweep time, meeting the 22 second long pulse reporting criteria and allowing a minimum of 10 seconds after the end of the long pulse waveform.

Should multiple RF ports be utilized for the Master and/or Slave devices (for example, for diversity or MIMO implementations), 50 ohm termination would be removed from the splitter so that connection can be established between splitter and the Master and/or Slave devices.

Conducted Method System Block Diagram

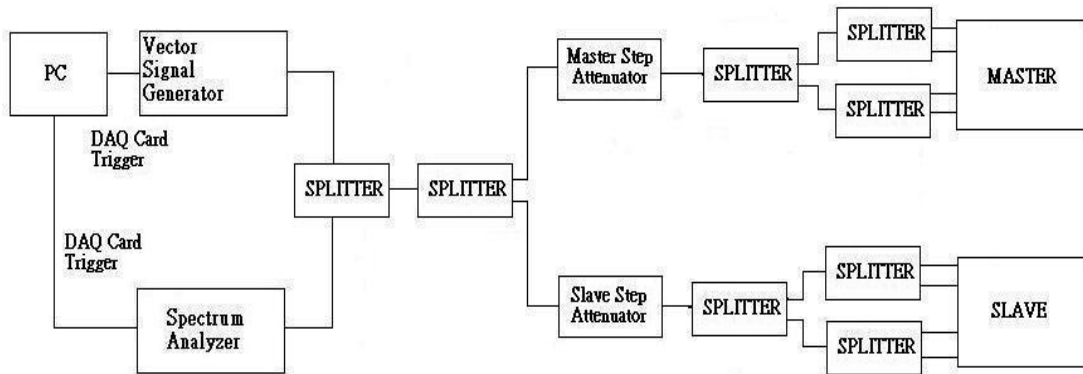

System Calibration

Connect the spectrum analyzer to the test system in place of the master device. Set the signal generator to CW mode. Adjust the amplitude of the signal generator to yield a measured level of -62 dBm on the spectrum analyzer.

Without changing any of the instrument settings, reconnect the spectrum analyzer to the Common port of the Spectrum Analyzer Combiner/Divider and connect a 50 ohm load to the Master Device port of the test system.

Measure the amplitude and calculate the difference from -62 dBm. Adjust the Reference Level Offset of the spectrum analyzer to this difference. Confirm that the signal is displayed at -62 dBm. Readjust the RBW and VBW to 3 MHz, set the span to 10 MHz, and confirm that the signal is still displayed at -62 dBm.

The spectrum analyzer displays the level of the signal generator as received at the antenna ports of the Master Device. The interference detection threshold may be varied from the calibrated value of -62 dBm and the spectrum analyzer will still indicate the level as received by the Master Device.

Set the signal generator to produce a radar waveform, trigger a burst manually and measure the level on the spectrum analyzer. Readjust the amplitude of the signal generator as required so that the peak level of the waveform is at a displayed level equal to the required or desired interference detection threshold. Separate signal generator amplitude settings are determined as required for each radar type.

Adjustment Of Displayed Traffic Level

Establish a link between the Master and Slave, adjusting the Link Step Attenuator as needed to provide a suitable received level at the Master and Slave devices. Stream the video test file to generate WLAN traffic. Confirm that the WLAN traffic level, as displayed on the spectrum analyzer, is at lower amplitude than the radar detection threshold. Confirm that the displayed traffic is from the Master Device. For Master Device testing confirm that the displayed traffic does not include Slave Device traffic. For Slave Device testing confirm that the displayed traffic does not include Master Device traffic.

If a different setting of the Master Step Attenuator is required to meet the above conditions, perform a new System Calibration for the new Master Step Attenuator setting.

4.7.3 Test Setup

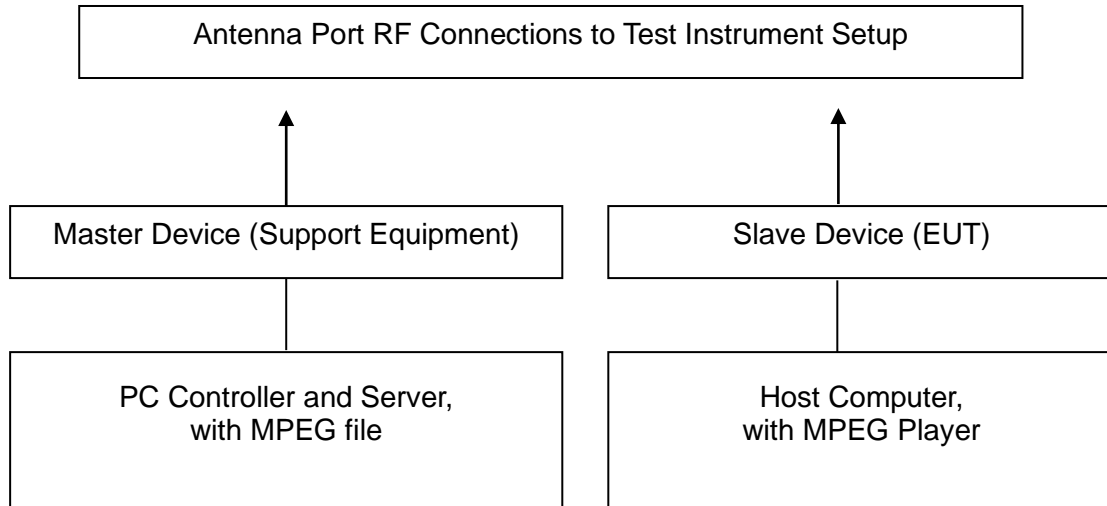

4.7.4 Test Result

U-NII-2a

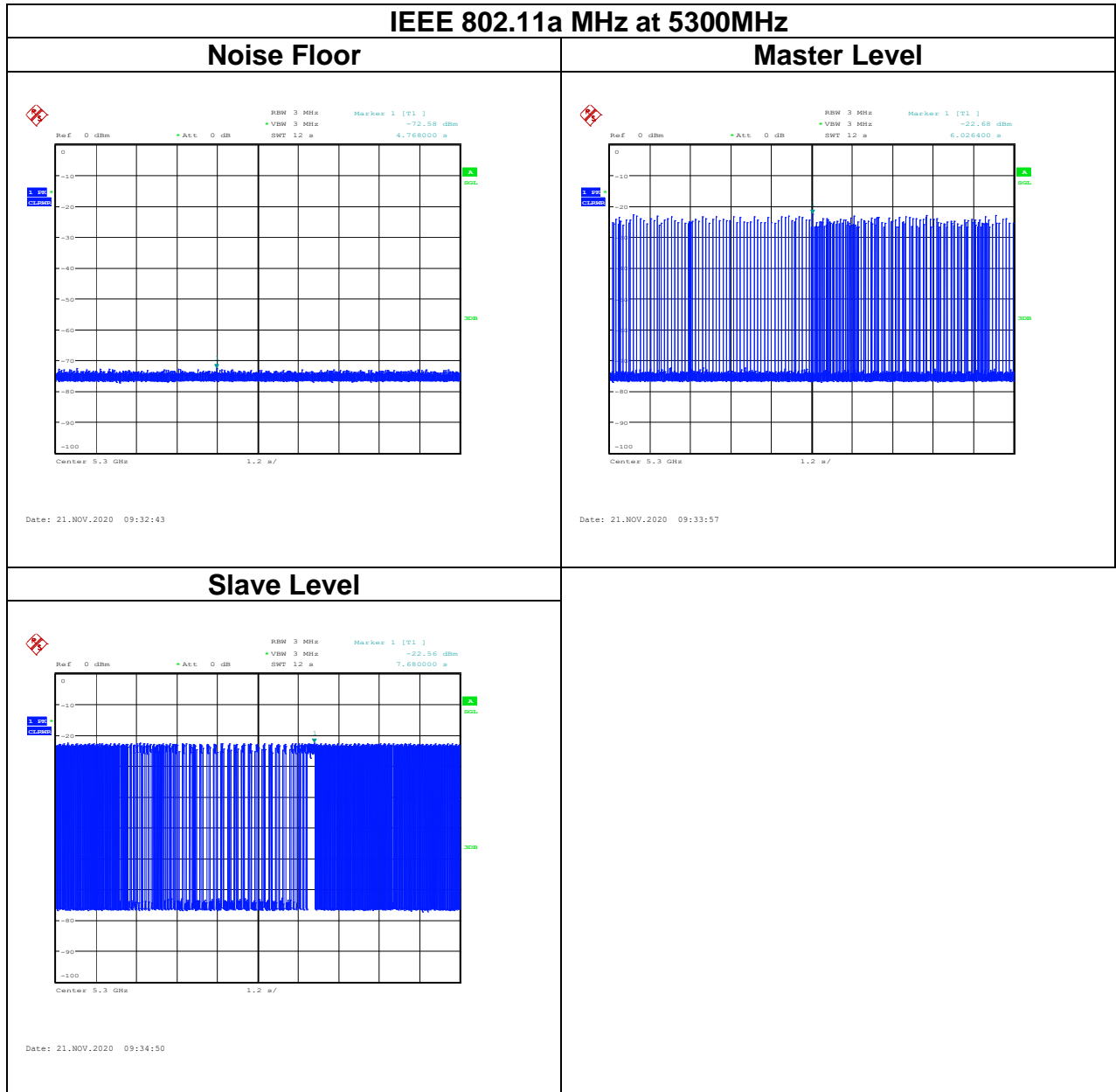

Report No.: T201104D06-RP4

Radar Waveforms

Sample of short Pluse Radar Type 0

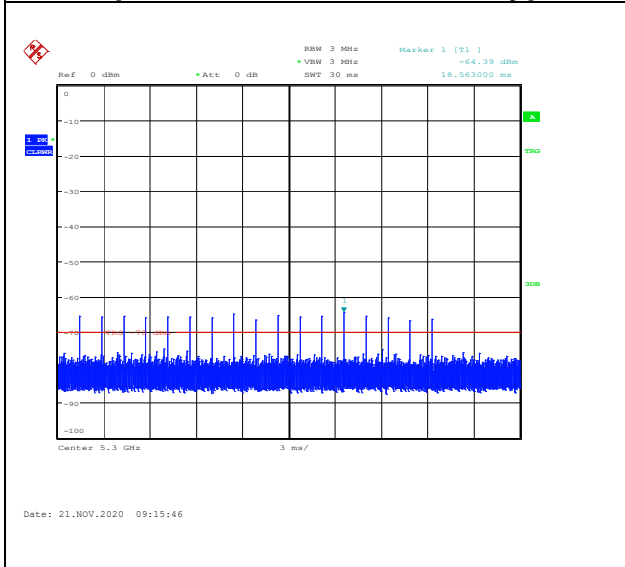

Report No.: T201104D06-RP4

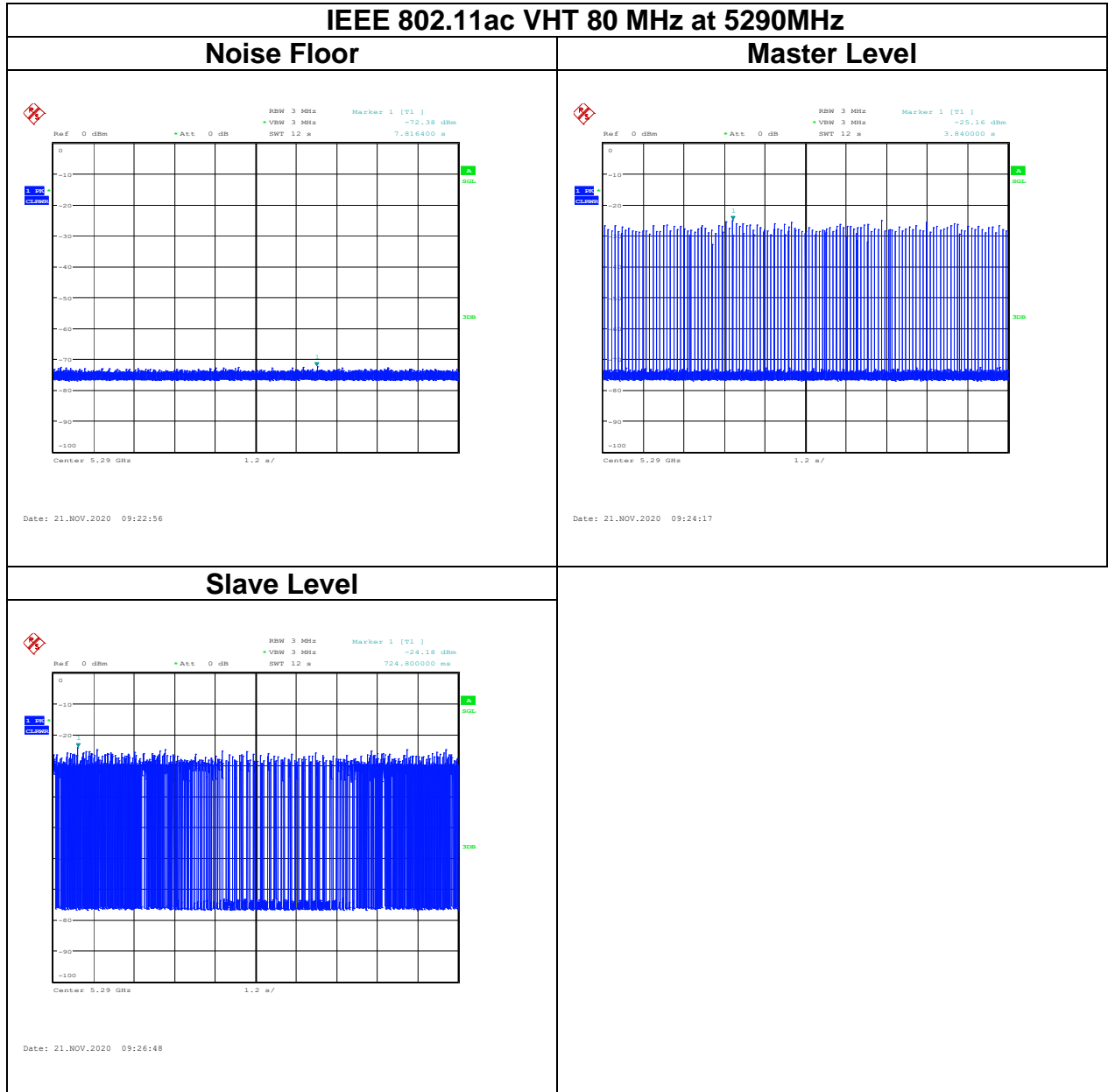

Radar Waveforms

Sample of short Pluse Radar Type 0

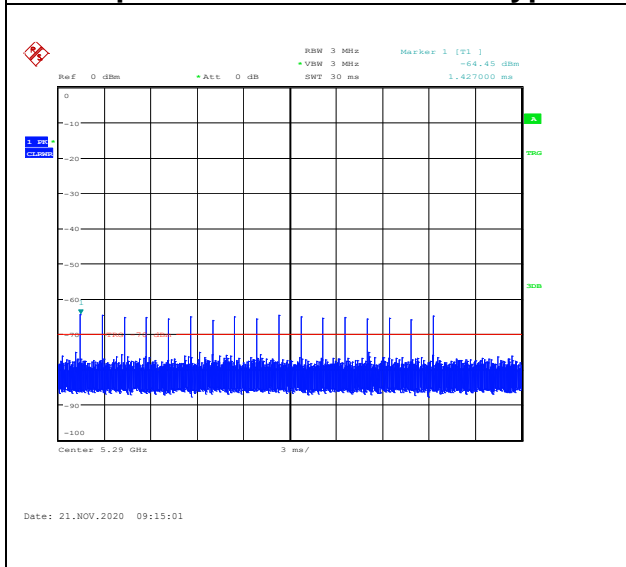

U-NII-2c

IEEE 802.11a at 5500MHz

Noise Floor

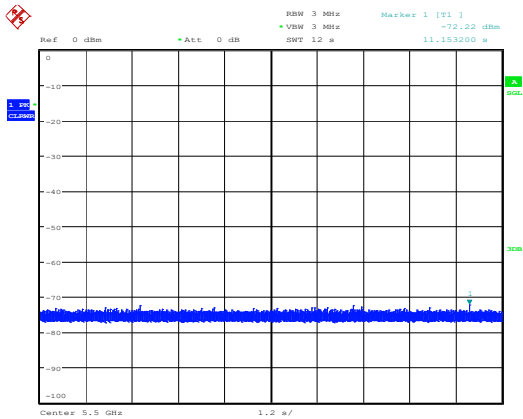

Date: 21.NOV.2020 09:55:39

Master Level

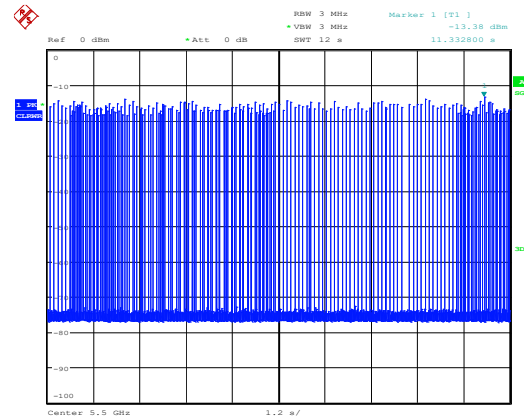

Date: 21.NOV.2020 09:57:10

Slave Level

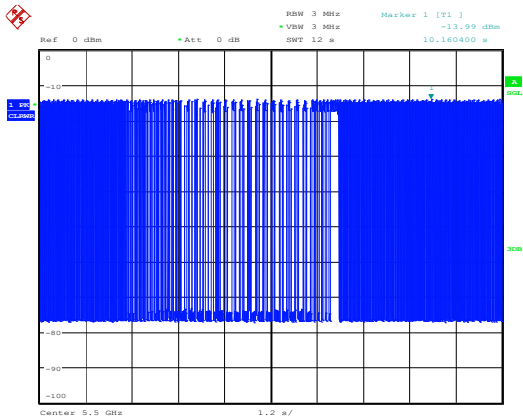

Date: 21.NOV.2020 09:57:50

Report No.: T201104D06-RP4

Radar Waveforms

Sample of short Pluse Radar Type 0

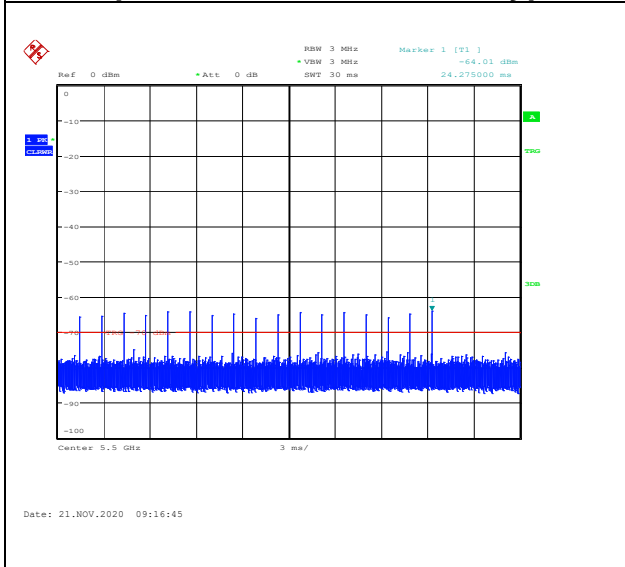

IEEE 802.11ac VHT 80 MHz at 5530MHz

Noise Floor

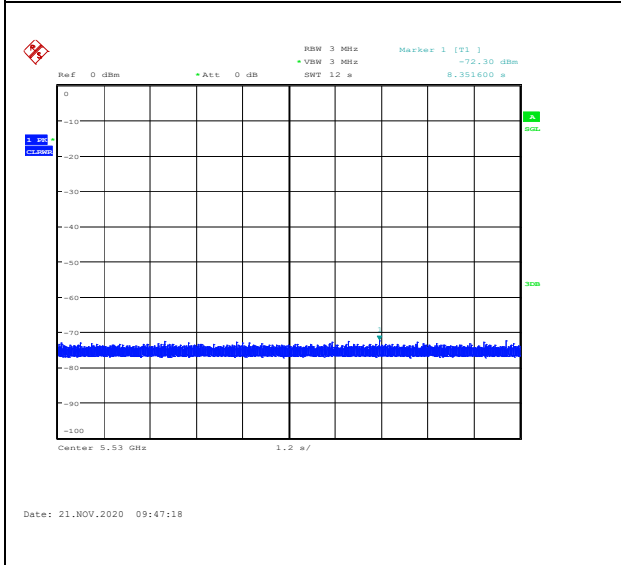

Master Level

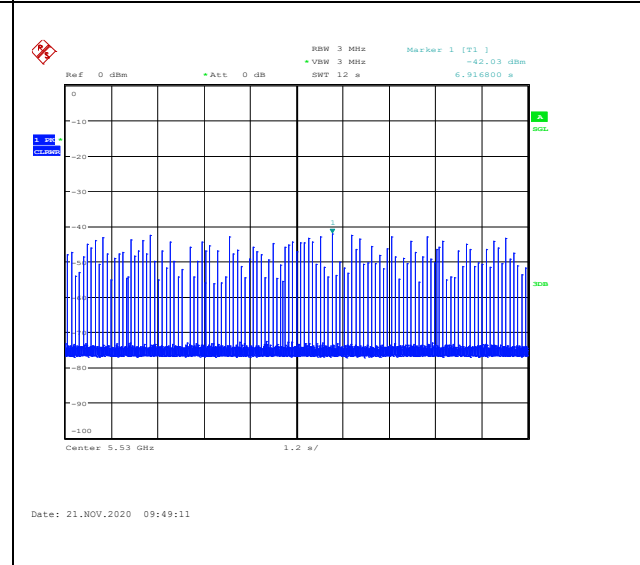

Slave Level

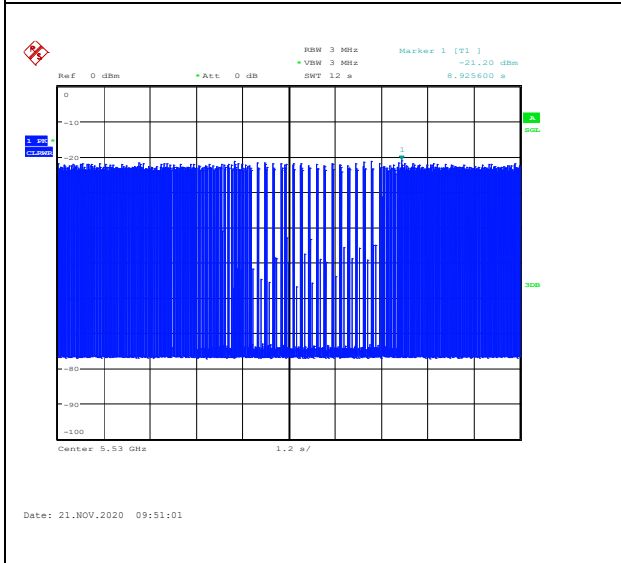

Report No.: T201104D06-RP4

Radar Waveforms

Sample of short Pluse Radar Type 0

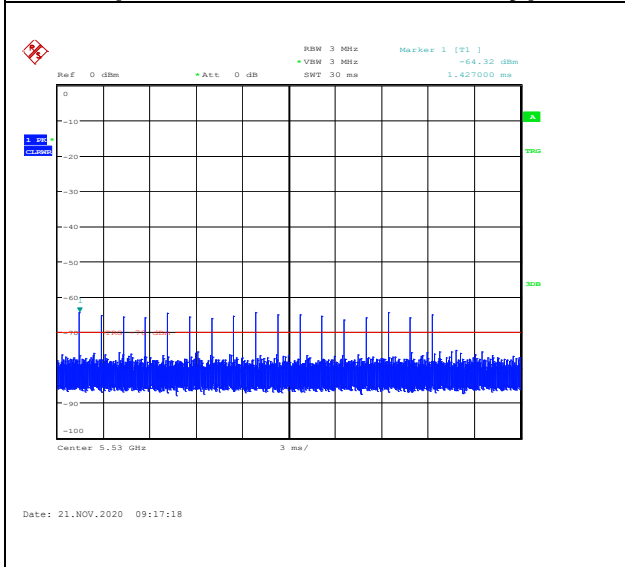

TEST CHANNEL AND METHOD

All tests were performed at a channel center frequency of 5310 MHz utilizing a conducted test method.

CHANNEL MOVE TIME AND CHANNEL CLOSING TRANSMISSION TIME**GENERAL REPORTING NOTES**

The reference marker is set at the end of last radar pulse.

The delta marker is set at the end of the last WLAN transmission following the radar pulse. This delta is the channel move time.

The aggregate channel closing transmission time is calculated as follows:

Aggregate Transmission Time =

(Number of analyzer bins showing transmission) * (dwell time per bin)

The observation period over which the aggregate time is calculated

Begins at (Reference Marker + 200 msec) and

Ends no earlier than (Reference Marker + 10 sec).

Report No.: T201104D06-RP4

U-NII-2a

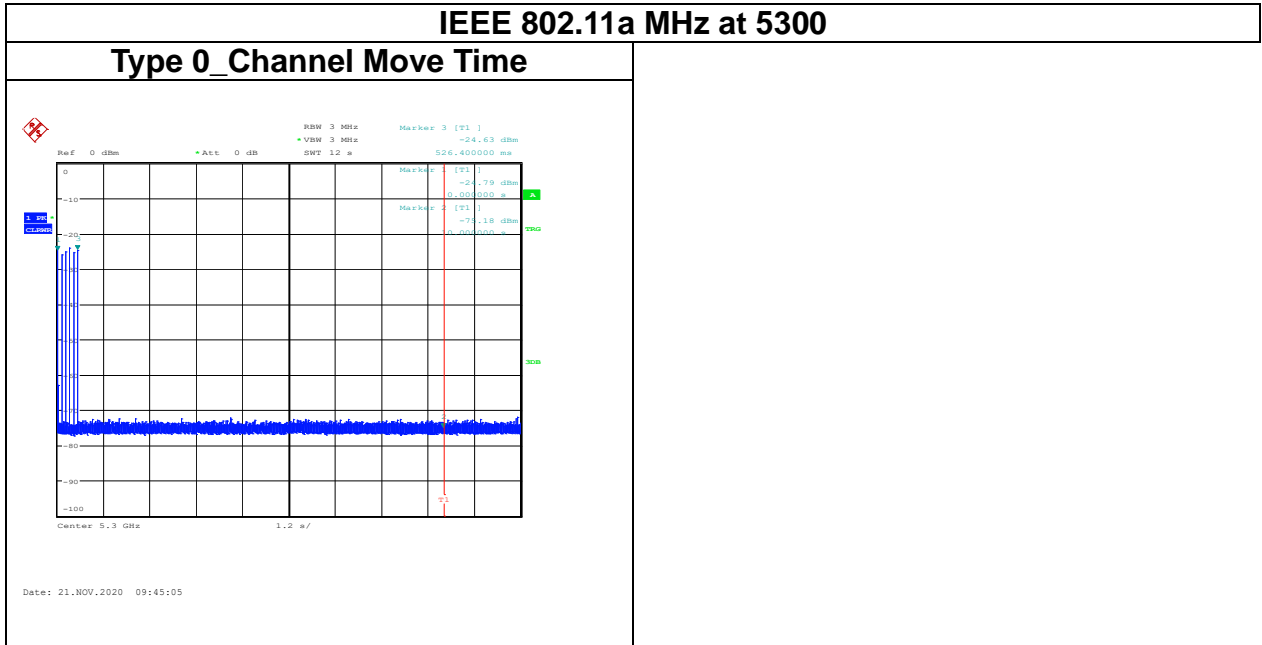

Channel Move Time (s)	Limit (s)
0.5264	10

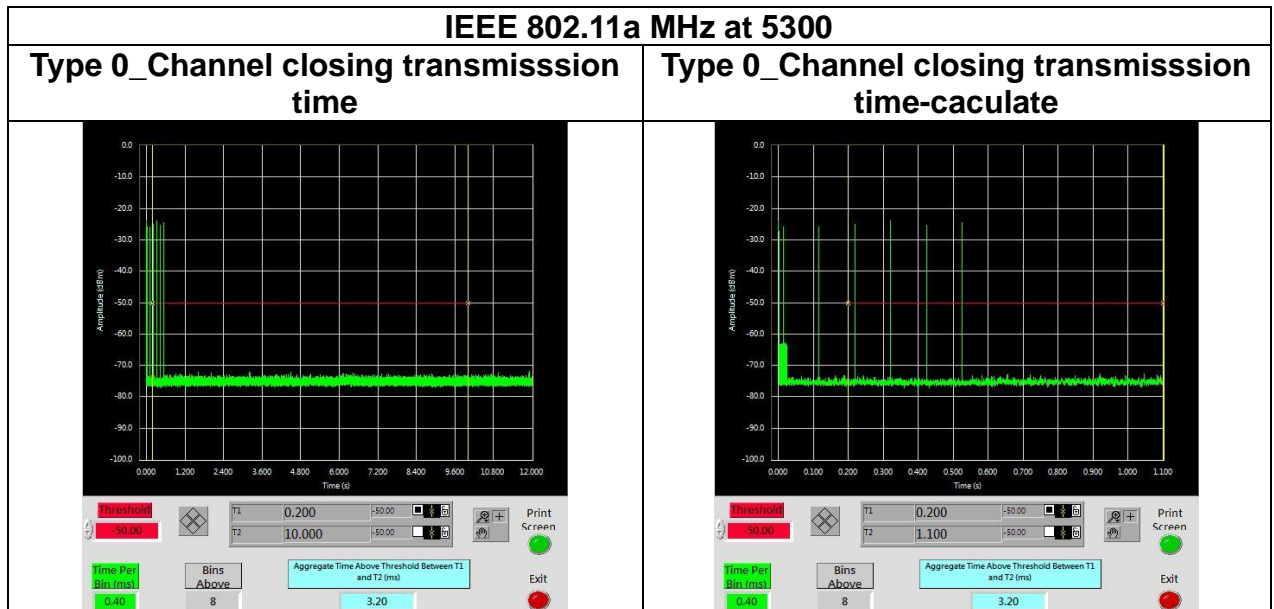

Aggregate Transmission Time (ms)	Limit (ms)	Margin (ms)
3.2	60	-56.8

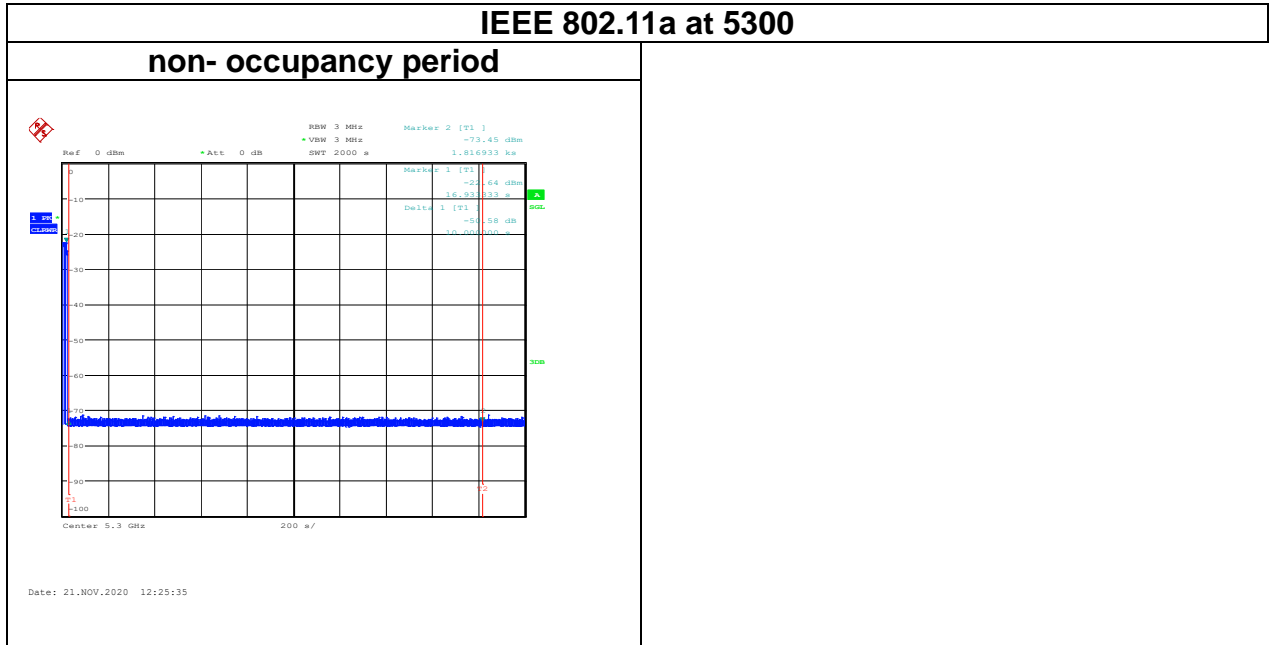

Report No.: T201104D06-RP4

IEEE 802.11ac VHT 80 MHz at 5290

Type 0_Channel Move Time

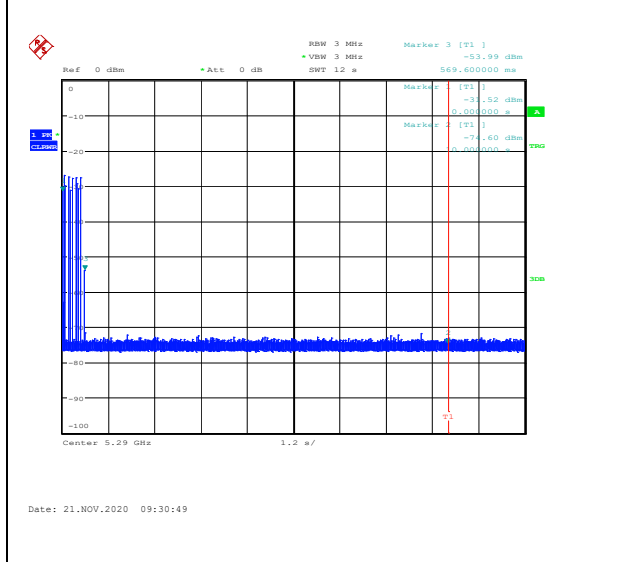

Channel Move Time (s)	Limit (s)
0.5696	10

IEEE 802.11ac VHT 80 MHz at 5290

Type 0_Channel closing transmission time

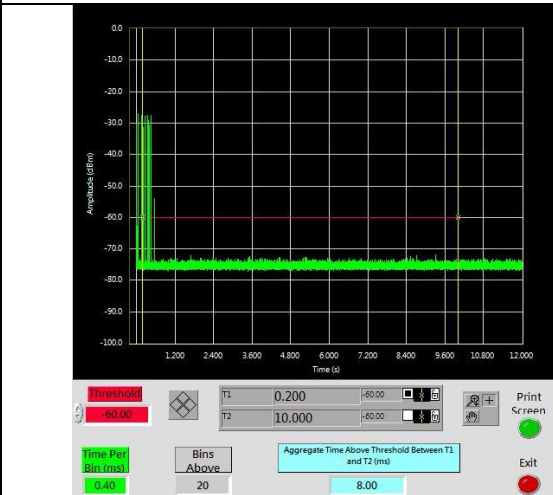

Type 0_Channel closing transmission time-caculate

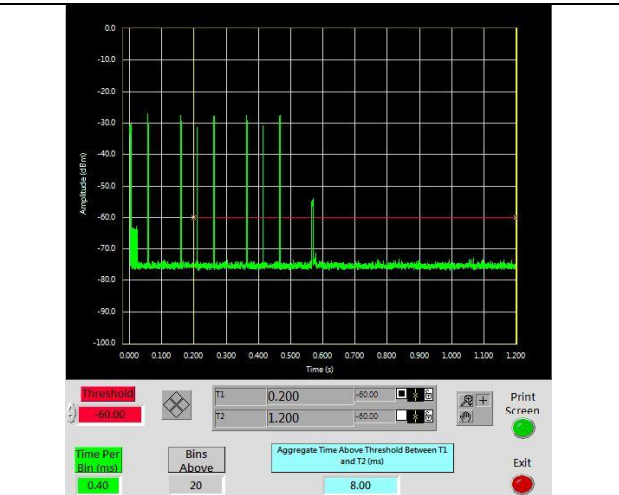

Aggregate Transmission Time (ms)	Limit (ms)	Margin (ms)
8.00	60	-52.00

Report No.: T201104D06-RP4

IEEE 802.11ac VHT 80 MHz at 5290

non- occupancy period

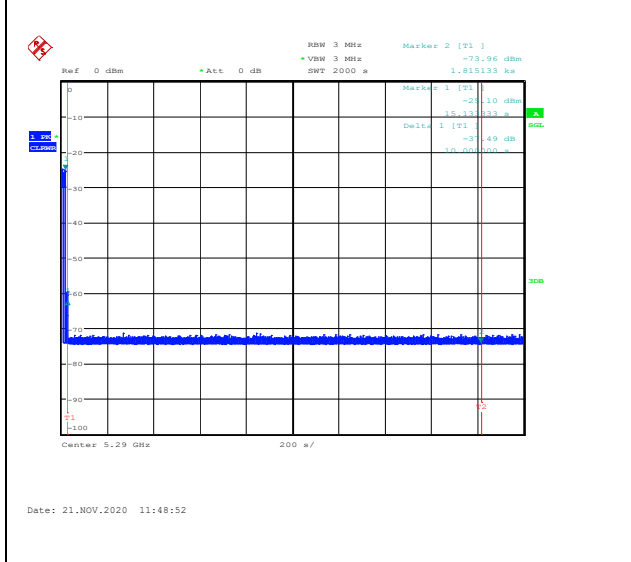

U-NII-2c

IEEE 802.11a at 5500

Type 0_Channel Move Time

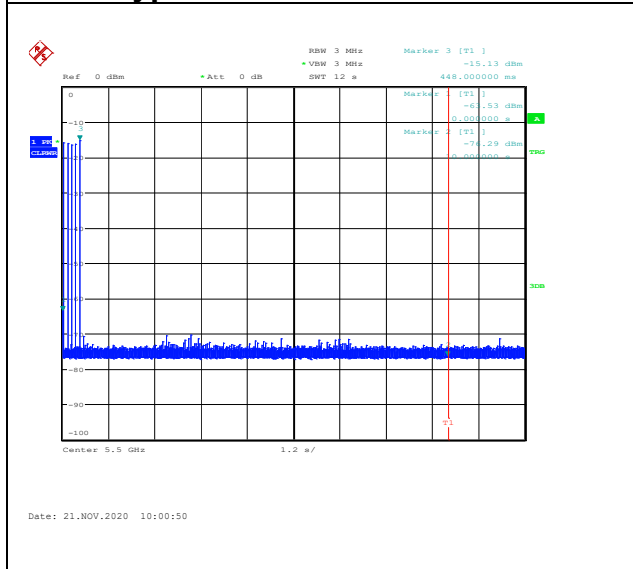

Channel Move Time (s)	Limit (s)
0.4480	10

IEEE 802.11a at 5500

Type 0_Channel closing transmission time

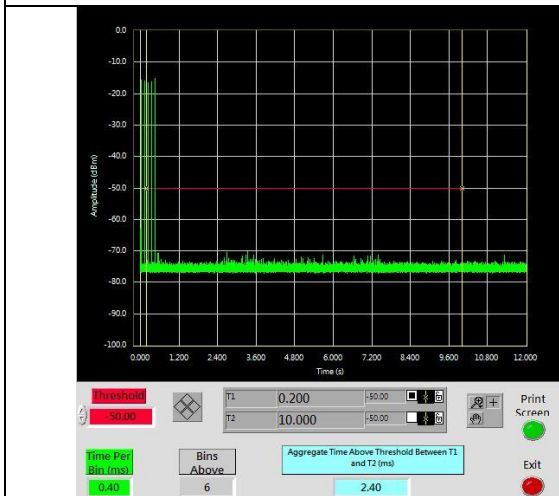

Type 0_Channel closing transmission time-caculate

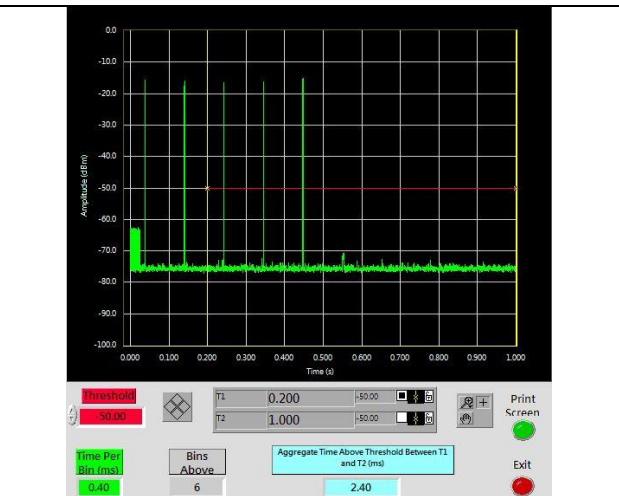

Aggregate Transmission Time (ms)	Limit (ms)	Margin (ms)
2.4	60	-57.6

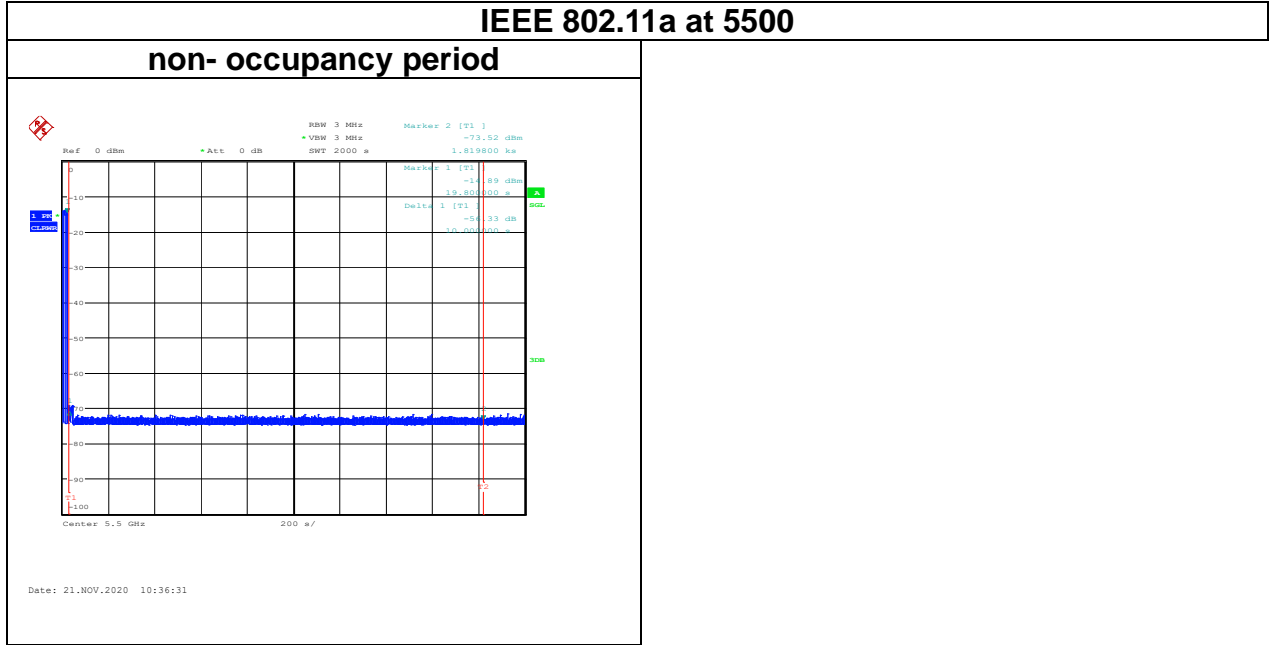

Report No.: T201104D06-RP4

IEEE 802.11ac VHT 80 MHz at 5530

Type 0_Channel Move Time

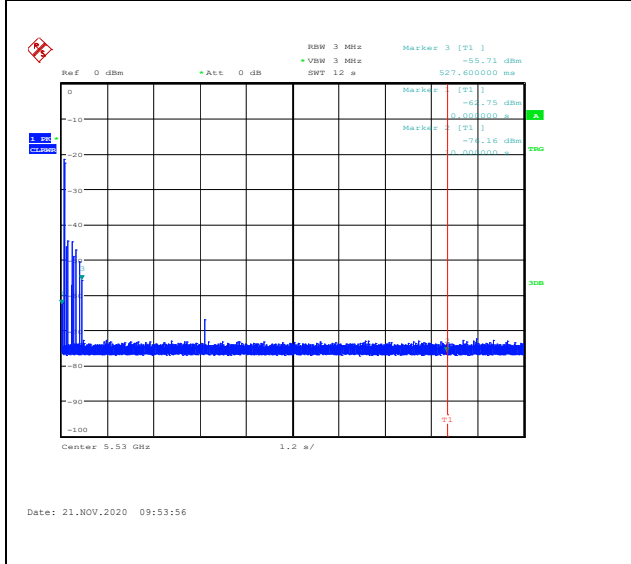

Channel Move Time (s)	Limit (s)
0.5276	10

IEEE 802.11ac VHT 80 MHz at 5530

Type 0_Channel closing transmission time

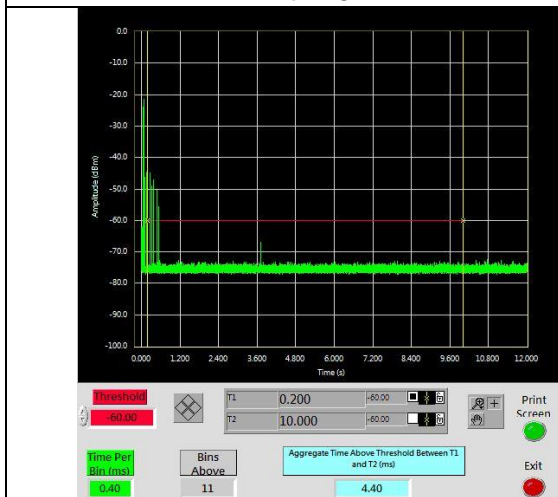

Type 0_Channel closing transmission time-caculate

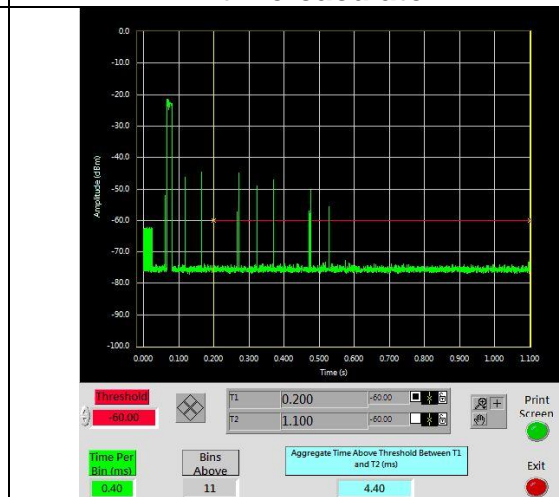

Aggregate Transmission Time (ms)	Limit (ms)	Margin (ms)
4.40	60	-55.6

Report No.: T201104D06-RP4

IEEE 802.11ac VHT 80 MHz at 5530

non- occupancy period

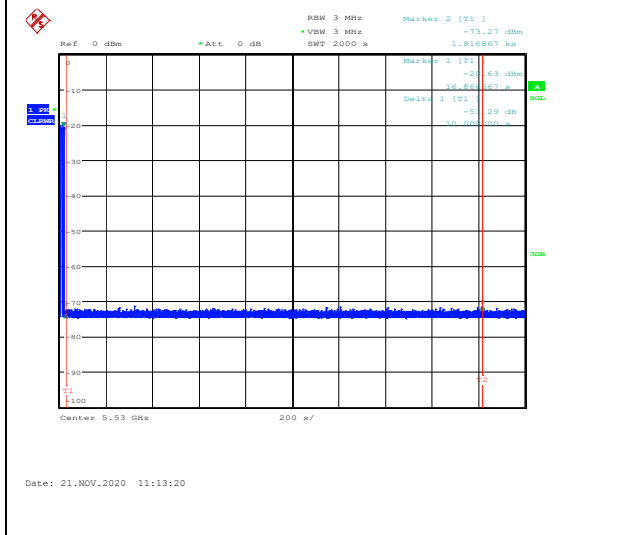

-- End of Test Report --