

FCC Test Report

FCC ID : 2AX7S-ATC63E
Equipment : Tablet PC
Model No. : ATC63E
Brand Name : AIMobile
Applicant : AIMobile Co., Ltd.
Address : 6F,No. 166,Section 4, Chengde Road, Shilin District, Taipei City, 11167 Taiwan
Standard : 47 CFR FCC Part 15.247
Received Date : Jan. 07, 2022
Tested Date : May 16 ~ May 23, 2022

We, International Certification Corporation, would like to declare that the tested sample has been evaluated and in compliance with the requirement of the above standards. The test results contained in this report refer exclusively to the product. It shall not be reproduced except in full without the written approval of our laboratory.

Reviewed by:

Approved by:



Along Chen / Assistant Manager



Gary Chang / Manager

Table of Contents

1	GENERAL DESCRIPTION	5
1.1	Information.....	5
1.2	Local Support Equipment List	8
1.3	Test Setup Chart	8
1.4	Test Equipment List and Calibration Data.....	9
1.5	Test Standards	10
1.6	Reference Guidance	10
1.7	Deviation from Test Standard and Measurement Procedure.....	10
1.8	Measurement Uncertainty	10
2	TEST CONFIGURATION.....	11
2.1	Testing Facility	11
2.2	The Worst Test Modes and Channel Details	11
3	TRANSMITTER TEST RESULTS	12
3.1	6dB and Occupied Bandwidth	12
3.2	Conducted Output Power	13
3.3	Power Spectral Density	14
3.4	Unwanted Emissions in Restricted Frequency Bands	15
3.5	Emissions in non-restricted Frequency Bands.....	17
3.6	AC Power Line Conducted Emissions	18
4	TEST LABORATORY INFORMATION	19

Appendix A. 6dB and Occupied Bandwidth

Appendix B. Conducted Output Power

Appendix C. Power Spectral Density

Appendix D. Unwanted Emissions into Restricted Frequency Bands

Appendix E. Emissions in Non-Restricted Frequency Bands

Appendix F. AC Power Line Conducted Emissions

Release Record

Report No.	Version	Description	Issued Date
FR210701AE	Rev. 01	Initial issue	Aug. 17, 2022
FR210701AE	Rev. 02	Version of Bluetooth is modified.	Sep. 22, 2022

Summary of Test Results

FCC Rules	Test Items	Measured	Result
15.207	AC Power Line Conducted Emissions	[dBuV]: 0.447MHz 39.48 (Margin -7.45dB) - AV	Pass
15.247(d) 15.209	Unwanted Emissions	[dBuV/m at 3m]: 71.64MHz 38.86 (Margin -1.14dB) - QP	Pass
15.247(b)(3)	Conducted Output Power	Power [dBm]: 6.67	Pass
15.247(a)(2)	6dB Bandwidth	Meet the requirement of limit	Pass
15.247(e)	Power Spectral Density	Meet the requirement of limit	Pass
15.203	Antenna Requirement	Meet the requirement of limit	Pass

Declaration of Conformity:

The test results with all measurement uncertainty excluded are presented in accordance with the regulation limits or requirements declared by manufacturers.

Comments and Explanations:

The declared of product specification for EUT presented in the report are provided by the manufacturer, and the manufacturer takes all the responsibilities for the accuracy of product specification.

1 General Description

1.1 Information

The EUT had six SKU options (SKU1, SKU2, SKU3, SKU1-2, SKU2-2 and SKU3-2). Six options were assessed and SKU2-2 was found to be worst case and was selected for the final testing.

1.1.1 SKU Details

The following SUKs are provided to this EUT.

SKU No.	SKU1	SKU2	SKU3	SKU1-2	SKU2-2	SKU3-2
SKU Description	Intel i3-1115G4E	Intel i5-1145G7E	Intel Celeron 6305E	Intel i3-1115G4E	Intel i5-1145G7E	Intel Celeron 6305E
	13.3"					
M/B	1310A3325001	1310A3325002	1310A3325003	1310A3325001	1310A3325002	1310A3325003
I/O Board	1310A3324701			1310A3388801		
	Audio Codec ALC256M			Audio Codec ALC888S		
Memory (LPDDR4)	Samsung 16GB			Samsung 16GB		
	M471A2K43EB1-CWE			M471A2K43EB1-CWE		
Storage (SSD)	Phison 1TB			Phison 1TB		
	PM81024GPKTCB5BINV-E13T4A			PM81024GPKTCB5BINV-E13T4A		
WLAN Module	Intel			Intel		
	AX210.NGWGII.NV			AX210.NGWGII.NV		
Note: The above SUK, SKU SKU2-2 was selected as a representative one for the final test and only its data was recorded in this report.						

1.1.2 Specification of the Equipment under Test (EUT)

RF General Information				
Frequency Range (MHz)	Bluetooth Mode	Ch. Freq. (MHz)	Channel Number	Data Rate
2400-2483.5	LE V5.2	2402-2480	0-39 [40]	125 kbps
				500 kbps
				1 Mbps
				2 Mbps
Note: Bluetooth LE (Low energy) uses GFSK modulation.				

1.1.3 Antenna Details

Ant. No.	Brand	Model	Type	Connector	Gain (dBi)
1	AWAN	AYF6Y-100184	PIFA	UFL	2.68

1.1.4 Power Supply Type of Equipment under Test (EUT)

Power Supply Type	19 Vdc from adapter 10.8 Vdc from battery
--------------------------	--

1.1.5 Accessories

Accessories		
No.	Equipment	Description
1	Adapter	Brand: FSP Model: FSP090-DBBN3 I/P: 100-240Vac, 50-60Hz, 1.5A O/P: 19.0Vdc, 4.74A, 90.0W Power Line: AC: 1m non-shielded without core DC: 1.45m non-shielded with one core
2	Adapter	Brand: FSP Model: FSP090-RBBM1 I/P: 100-240Vac, 50-60Hz, 1.5-0.6A O/P: 19.0Vdc, 4.74A, 90.0W Power Line: AC: 1m non-shielded without core DC: 1.4m non-shielded with one core
3	Rechargeable Li-ion Battery	Model: ATC-63E-BAT Normal Voltage: 10.8Vdc Rating: 4660mAh (50.3Wh) Charge Voltage Limit: 12.6Vdc

Note: Two adapters (FSP090-DBBN3 and FSP090-RBBM1) had been covered during the pretest, and found that FSP090-DBBN3 adapter was the worst case and was selected for final test.

1.1.6 Channel List

Frequency band (MHz)				2400~2483.5			
Channel	Frequency (MHz)	Channel	Frequency (MHz)	Channel	Frequency (MHz)	Channel	Frequency (MHz)
37	2402	9	2422	18	2442	28	2462
0	2404	10	2424	19	2444	29	2464
1	2406	38	2426	20	2446	30	2466
2	2408	11	2428	21	2448	31	2468
3	2410	12	2430	22	2450	32	2470
4	2412	13	2432	23	2452	33	2472
5	2414	14	2434	24	2454	34	2474
6	2416	15	2436	25	2456	35	2476
7	2418	16	2438	26	2458	36	2478
8	2420	17	2440	27	2460	39	2480

1.1.7 Test Tool and Duty Cycle

Test Tool	DRTU, Version: V0.1032.22.130.0	
Modulation Mode	Duty Cycle Of Test Signal (%)	Duty Factor (dB)
BT-LE(125kbps)	98.39%	0.07
BT-LE(500kbps)	92.19%	0.35
BT-LE(1Mbps)	86.24%	0.64
BT-LE(2Mbps)	59.07%	2.29

1.1.8 Power Index of Test Tool

Modulation Mode	Test Frequency (MHz)		
	2402	2440	2480
BT-LE(125kbps)	default	default	default
BT-LE(500kbps)	default	default	default
BT-LE(1Mbps)	default	default	default
BT-LE(2Mbps)	default	default	default

1.2 Local Support Equipment List

Support Equipment List					
No.	Equipment	Brand	Model	FCC ID	Remarks
1	Notebook	DELL	Latitude E5470	DoC	---
2	USB Flash	pqi(USB 3.1 Type-C)	Connect 313/16GB	---	---
3	USB Flash	Transcend(USB 3.0)	JetFlash 700	---	---
4	USB Flash	Transcend(USB 3.0)	JetFlash 700	---	---
5	Earphone	Samsung	EHS64	---	---
6	LCD Monitor	ASUS(27")	MX27UCS	---	---

1.3 Test Setup Chart

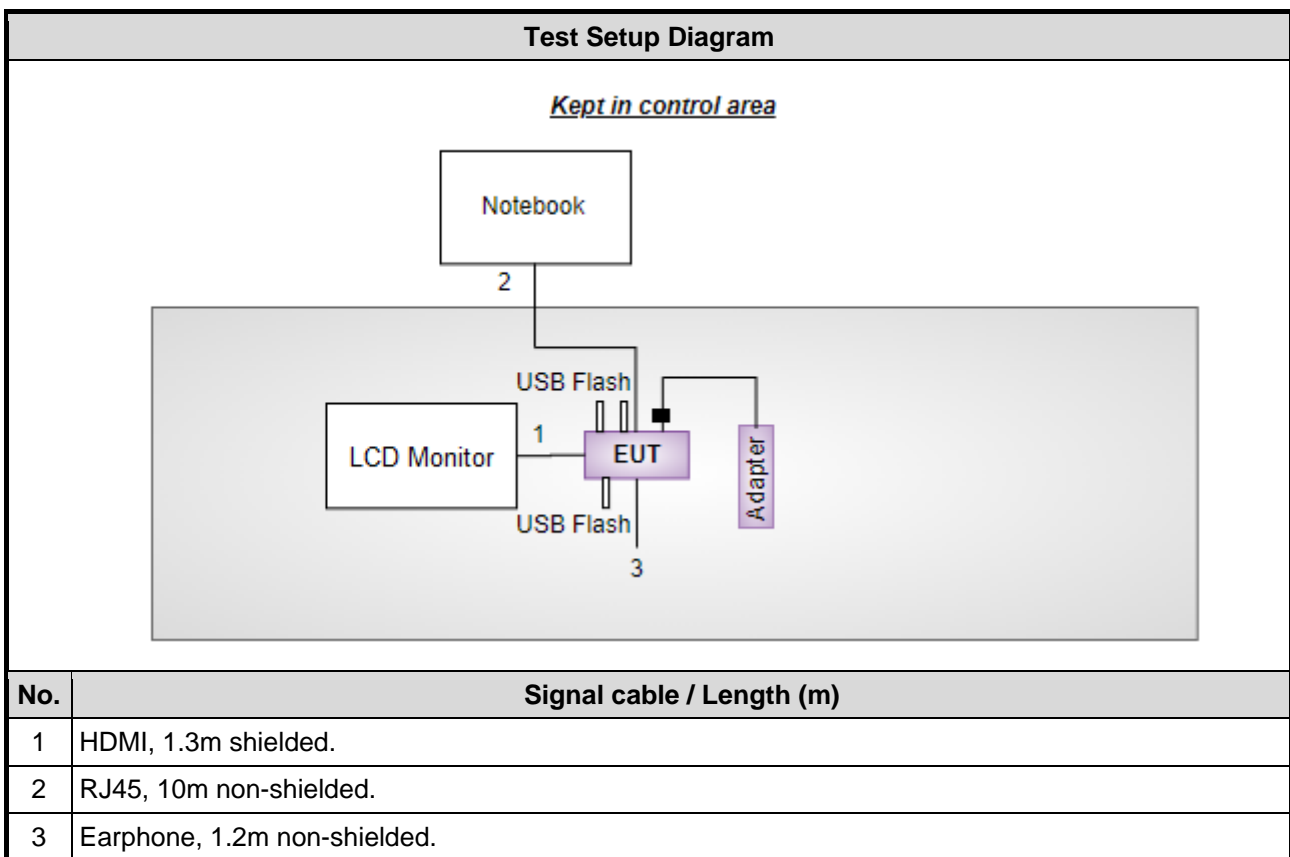

1.4 Test Equipment List and Calibration Data

Test Item	Conducted Emission				
Test Site	Conduction room 1 / (CO01-WS)				
Tested Date	May 16, 2022				
Instrument	Brand	Model No.	Serial No.	Calibration Date	Calibration Until
Receiver	R&S	ESR3	101658	Feb. 16, 2022	Feb. 15, 2023
LISN	R&S	ENV216	101579	Apr. 21, 2022	Apr. 20, 2023
LISN (Support Unit)	SCHWARZBECK	Schwarzbeck 8127	8127667	Jan .07, 2022	Jan .06, 2023
RF Cable-CON	Woken	CFD200-NL	CFD200-NL-001	Oct. 19, 2021	Oct. 18, 2022
50 ohm terminal (Support Unit)	NA	50	04	May 25, 2021	May 24, 2022
Measurement Software	AUDIX	e3	6.120210k	NA	NA

Note: Calibration Interval of instruments listed above is one year.

Test Item	Radiated Emission				
Test Site	966 chamber1 / (03CH01-WS)				
Tested Date	May 16, 2022				
Instrument	Brand	Model No.	Serial No.	Calibration Date	Calibration Until
Receiver	R&S	ESR3	101657	Mar. 15, 2022	Mar. 14, 2023
Spectrum Analyzer	R&S	FSV40	101498	Nov. 29, 2021	Nov. 28, 2022
Loop Antenna	R&S	HFH2-Z2	100330	Nov. 08, 2021	Nov. 07, 2022
Bilog Antenna	SCHWARZBECK	VULB9168	VULB9168-522	Jun. 30, 2021	Jun. 29, 2022
Horn Antenna 1G-18G	SCHWARZBECK	BBHA 9120 D	BBHA 9120 D 1096	Dec. 03, 2021	Dec. 02, 2022
Horn Antenna 18G-40G	SCHWARZBECK	BBHA 9170	BBHA 9170508	Jan. 11, 2022	Jan. 10, 2023
Preamplifier	EMC	EMC02325	980225	Jun. 29, 2021	Jun. 28, 2022
Preamplifier	Agilent	83017A	MY39501308	Sep. 28, 2021	Sep. 27, 2022
Preamplifier	EMC	EMC184045B	980192	Jul. 14, 2021	Jul. 13, 2022
Loop Antenna Cable	KOAX KABEL	101354-BW	101354-BW	Oct. 05, 2021	Oct. 04, 2022
LF cable 3M	Woken	CFD400NL-LW	CFD400NL-001	Oct. 05, 2021	Oct. 04, 2022
LF cable 11M	EMC	EMCCFD400-NW-N W-11000	200801	Oct. 05, 2021	Oct. 04, 2022
LF cable 1M	EMC	EMCCFD400-NM-N M-1000	160502	Oct. 05, 2021	Oct. 04, 2022
RF Cable	EMC	EMC104-35M-35M-8000	210920	Oct. 05, 2021	Oct. 04, 2022
RF Cable	HUBER+SUHNER	SUCOFLEX104	MY16019/4	Oct. 05, 2021	Oct. 04, 2022
Measurement Software	AUDIX	e3	6.120210g	NA	NA

Note: Calibration Interval of instruments listed above is one year.

Test Item	RF Conducted				
Test Site	(TH01-WS)				
Tested Date	May 23, 2022				
Instrument	Brand	Model No.	Serial No.	Calibration Date	Calibration Until
Spectrum Analyzer	R&S	FSV40	101910	Apr. 18, 2022	Apr. 17, 2023
Power Meter	Anritsu	ML2495A	1241002	Nov. 07, 2021	Nov. 06, 2022
Power Sensor	Anritsu	MA2411B	1207366	Nov. 07, 2021	Nov. 06, 2022
Measurement Software	Sporton	SENSE-15247_FS	V5.10.7.11	NA	NA
Note: Calibration Interval of instruments listed above is one year.					

1.5 Test Standards

47 CFR FCC Part 15.247
ANSI C63.10-2013

1.6 Reference Guidance

FCC KDB 558074 D01 15.247 Meas Guidance v05r02

1.7 Deviation from Test Standard and Measurement Procedure

None

1.8 Measurement Uncertainty

The measurement uncertainties given below are based on a 95% confidence level (based on a coverage factor ($k=2$)).

Measurement Uncertainty	
Parameters	Uncertainty
Bandwidth	± 34.130 Hz
Conducted power	± 0.808 dB
Power density	± 0.583 dB
Conducted emission	± 2.715 dB
AC conducted emission	± 2.92 dB
Unwanted Emission ≤ 1 GHz	± 3.41 dB
Unwanted Emission > 1 GHz	± 4.59 dB

2 Test Configuration

2.1 Testing Facility

Test Laboratory	International Certification Corporation
Test Site	CO01-WS, 03CH01-WS, TH01-WS
Address of Test Site	No.3-1, Lane 6, Wen San 3rd St., Kwei Shan Dist., Tao Yuan City 33381, Taiwan (R.O.C.)

- FCC Designation No.: TW2732
- FCC site registration No.: 181692
- ISED#: 10807A
- CAB identifier: TW2732

2.2 The Worst Test Modes and Channel Details

Test item	Mode	Test Frequency (MHz)	Test Configuration
AC Power Line Conducted Emissions	BT-LE(1Mbps)	2402	---
Unwanted Emissions ≤ 1GHz	BT-LE(1Mbps)	2402	---
Unwanted Emissions > 1GHz	BT-LE(1Mbps) BT-LE(2Mbps)	2402, 2440, 2480	---
Conducted Output Power 6dB bandwidth Power spectral density	BT-LE(125kbps) BT-LE(500kbps) BT-LE(1Mbps) BT-LE(2Mbps)	2402, 2440, 2480	---
NOTE:			
1. The EUT was pretested with 3 orientations placed on the table for the radiated emission measurement – X, Y, and Z-plane. The Z-plane results were found as the worst case and were shown in this report.			

3 Transmitter Test Results

3.1 6dB and Occupied Bandwidth

3.1.1 Limit of 6dB Bandwidth

The minimum 6dB bandwidth shall be at least 500 kHz.

3.1.2 Test Procedures

6dB Bandwidth

1. Set resolution bandwidth (RBW) = 100 kHz, Video bandwidth = 300 kHz.
2. Detector = Peak, Trace mode = max hold.
3. Sweep = auto couple, Allow the trace to stabilize.
4. Measure the maximum width of the emission that is constrained by the frequencies associated with the two outermost amplitude points (upper and lower) that are attenuated by 6dB relative to the maximum level measured in the fundamental emission.

Occupied Bandwidth

1. Set resolution bandwidth (RBW) = 1% ~ 5 % of OBW, Video bandwidth = 3 x RBW
2. Detector = Sample, Trace mode = max hold.
3. Sweep = auto couple, Allow the trace to stabilize.
4. Use the OBW measurement function of spectrum analyzer to measure the occupied bandwidth.

3.1.3 Test Setup

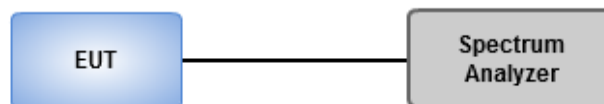

3.1.4 Test Results

Ambient Condition	23°C / 64%	Tested By	Brad Wu
--------------------------	------------	------------------	---------

Refer to Appendix A.

3.2 Conducted Output Power

3.2.1 Limit of Conducted Output Power

Conducted power shall not exceed 1Watt.

Antenna gain $\leq 6\text{dBi}$, no any corresponding reduction is in output power limit.

3.2.2 Test Procedures

A broadband RF power meter is used for output power measurement. The video bandwidth of power meter is greater than DTS bandwidth of EUT. If duty cycle of test signal is not 100 %, trigger and gating function of power meter will be enabled to capture transmission burst for measuring output power.

3.2.3 Test Setup

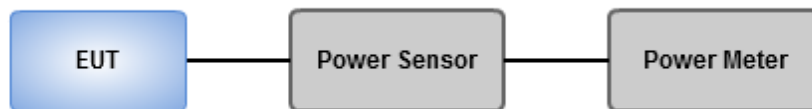

3.2.4 Test Results

Ambient Condition	23°C / 64%	Tested By	Brad Wu
--------------------------	------------	------------------	---------

Refer to Appendix B.

3.3 Power Spectral Density

3.3.1 Limit of Power Spectral Density

Power spectral density shall not be greater than 8 dBm in any 3 kHz band.

3.3.2 Test Procedures

1. Set the RBW = 3 kHz, VBW = 10 kHz.
2. Detector = Peak, Sweep time = auto couple.
3. Trace mode = max hold, allow trace to fully stabilize.
4. Use the peak marker function to determine the maximum amplitude level.

3.3.3 Test Setup

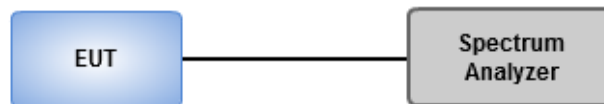

3.3.4 Test Results

Ambient Condition	23°C / 64%	Tested By	Brad Wu
--------------------------	------------	------------------	---------

Refer to Appendix C.

3.4 Unwanted Emissions in Restricted Frequency Bands

3.4.1 Limit of Unwanted Emissions in Restricted Frequency Bands

Restricted Band Emissions Limit			
Frequency Range (MHz)	Field Strength (uV/m)	Field Strength (dBuV/m)	Measure Distance (m)
0.009~0.490	2400/F(kHz)	48.5 - 13.8	300
0.490~1.705	24000/F(kHz)	33.8 - 23	30
1.705~30.0	30	29	30
30~88	100	40	3
88~216	150	43.5	3
216~960	200	46	3
Above 960	500	54	3

Note 1:
Qusai-Peak value is measured for frequency below 1GHz except for 9–90 kHz, 110–490 kHz frequency band. Peak and average value are measured for frequency above 1GHz. The limit on average radio frequency emission is as above table. The limit on peak radio frequency emissions is 20 dB above the maximum permitted average emission limit

Note 2:
Measurements may be performed at a distance other than what is specified provided. When performing measurements at a distance other than that specified, the results shall be extrapolated to the specified distance using an extrapolation factor as below, Frequency at or above 30 MHz: 20 dB/decade Frequency below 30 MHz: 40 dB/decade.

3.4.2 Test Procedures

1. Measurement is made at a semi-anechoic chamber that incorporates a turntable allowing a EUT rotation of 360°. A continuously-rotating, remotely-controlled turntable is installed at the test site to support the EUT and facilitate determination of the direction of maximum radiation for each EUT emission frequency. The EUT is placed at test table. For emissions testing at or below 1 GHz, the table height is 80 cm above the reference ground plane. For emission measurements above 1 GHz, the table height is 1.5 m
2. Measurement is made with the antenna positioned in both the horizontal and vertical planes of polarization. The measurement antenna is varied in height (1m ~ 4m) above the reference ground plane to obtain the maximum signal strength. Distance between EUT and antenna is 3 m.
3. This investigation is performed with the EUT rotated 360°, the antenna height scanned between 1 m and 4 m, and the antenna rotated to repeat the measurements for both the horizontal and vertical antenna polarizations.

Note:

1. 120kHz measurement bandwidth of test receiver and Quasi-peak detector is for radiated emission below 1GHz.
2. RBW=1MHz, VBW=3MHz and Peak detector is for peak measured value of radiated emission above 1GHz.
3. RBW=1MHz, VBW=1/T and Peak detector is for average measured value of radiated emission above 1GHz.

3.4.3 Test Setup

Radiated Emissions below 1 GHz

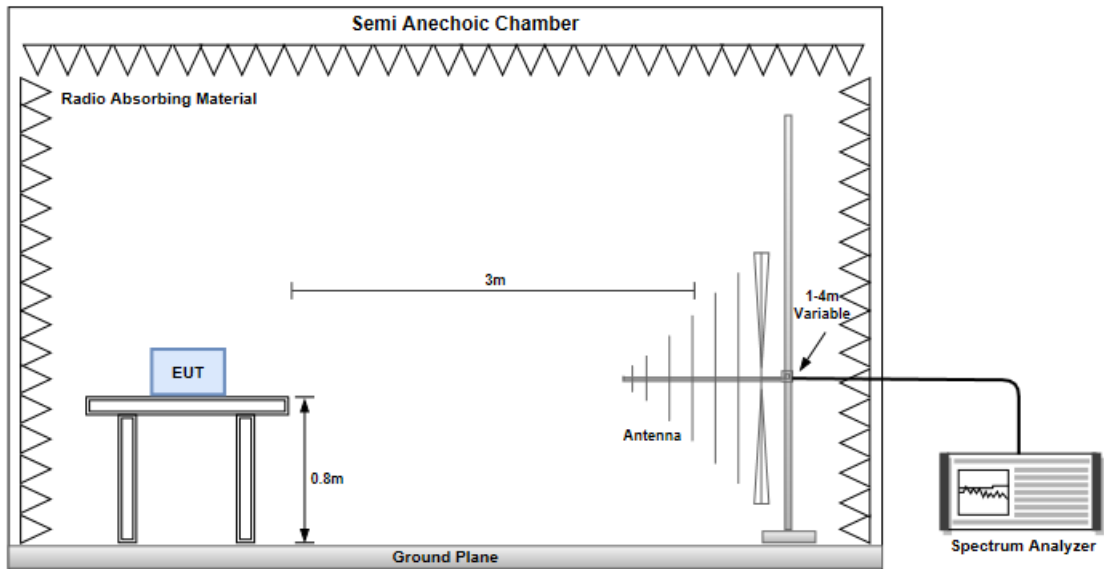

Radiated Emissions above 1 GHz

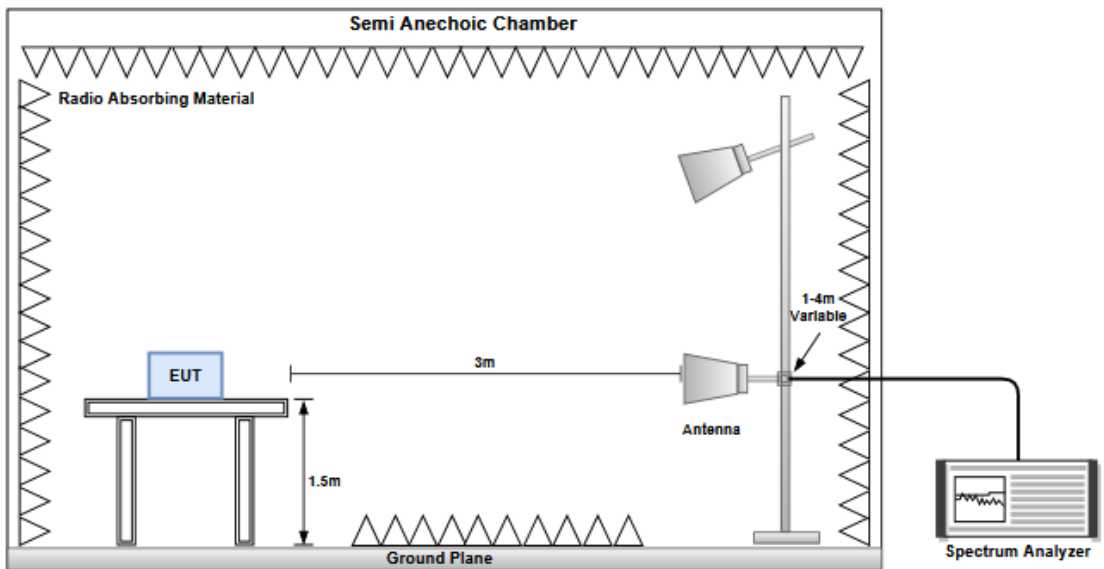

3.4.4 Test Results

Refer to Appendix D.

3.5 Emissions in non-restricted Frequency Bands

3.5.1 Emissions in non-restricted frequency bands limit

Peak power in any 100 kHz bandwidth outside of the authorized frequency band shall be attenuated by at least 20 dB relative to the maximum in-band peak PSD level in 100 kHz.

3.5.2 Test Procedures

Reference level measurement

1. Set RBW=100kHz, VBW = 300kHz , Detector = Peak, Sweep time = Auto
2. Trace = max hold , Allow Trace to fully stabilize
3. Use the peak marker function to determine the maximum PSD level

Emission level measurement

1. Set RBW=100kHz, VBW = 300kHz , Detector = Peak, Sweep time = Auto
2. Trace = max hold , Allow Trace to fully stabilize
3. Scan Frequency range is up to 25GHz
4. Use the peak marker function to determine the maximum amplitude level

3.5.3 Test Setup

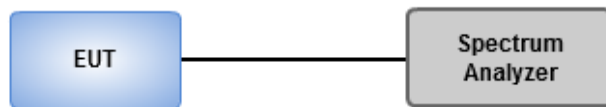

3.5.4 Test Results

Ambient Condition	23°C / 64%	Tested By	Brad Wu
--------------------------	------------	------------------	---------

Refer to Appendix E.

3.6 AC Power Line Conducted Emissions

3.6.1 Limit of AC Power Line Conducted Emissions

Conducted Emissions Limit		
Frequency Emission (MHz)	Quasi-Peak	Average
0.15-0.5	66 - 56 *	56 - 46 *
0.5-5	56	46
5-30	60	50

Note 1: * Decreases with the logarithm of the frequency.

3.6.2 Test Procedures

1. The device is placed on a test table, raised 80 cm above the reference ground plane. The vertical conducting plane is located 40 cm to the rear of the device.
2. The device is connected to line impedance stabilization network (LISN) and other accessories are connected to other LISN. Measured levels of AC power line conducted emission are across the 50 Ω LISN port.
3. AC conducted emission measurements is made over frequency range from 150 kHz to 30 MHz.
4. This measurement was performed with AC 120V/60Hz

3.6.3 Test Setup

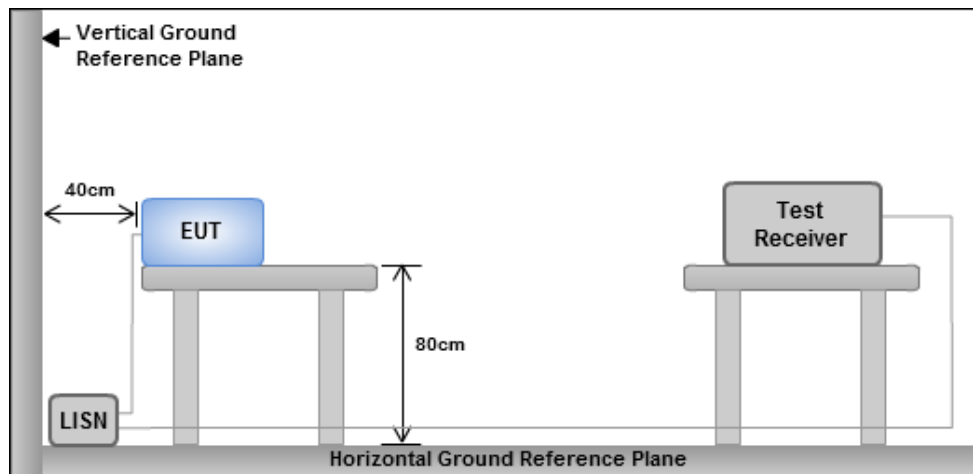

- Note: 1. Support units were connected to second LISN.
 2. Both of LISNs (AMN) are 80 cm from EUT and at least 80 cm from other units and other metal planes

3.6.4 Test Results

Refer to Appendix F.

4 Test laboratory information

Established in 2012, ICC provides foremost EMC & RF Testing and advisory consultation services by our skilled engineers and technicians. Our services employ a wide variety of advanced edge test equipment and one of the widest certification extents in the business.

International Certification Corporation (EMC and Wireless Communication Laboratory), it is our definitive objective is to institute long term, trust-based associations with our clients. The expectation we set up with our clients is based on outstanding service, practical expertise and devotion to a certified value structure. Our passion is to grant our clients with best EMC / RF services by oriented knowledgeable and accommodating staff.

Our Test sites are located at Linkou District and Kwei Shan District. Location map can be found on our website <http://www.icertifi.com.tw>.

Linkou

Tel: 886-2-2601-1640

No.30-2, Ding Fwu Tsuen, Lin Kou
District, New Taipei City, Taiwan
(R.O.C.)

Kwei Shan

Tel: 886-3-271-8666

No.3-1, Lane 6, Wen San 3rd
St., Kwei Shan Dist., Tao Yuan
City 33381, Taiwan (R.O.C.)
No.2-1, Lane 6, Wen San 3rd
St., Kwei Shan Dist., Tao Yuan
City 33381, Taiwan (R.O.C.)

Kwei Shan Site II

Tel: 886-3-271-8640

No.14-1, Lane 19, Wen San 3rd
St., Kwei Shan Dist., Tao Yuan
City 333, Taiwan (R.O.C.)

If you have any suggestion, please feel free to contact us as below information.

Tel: 886-3-271-8666

Fax: 886-3-318-0155

Email: ICC_Service@icertifi.com.tw

==END==



Summary

Mode	Max-N dB (Hz)	Max-OBW (Hz)	ITU-Code	Min-N dB (Hz)	Min-OBW (Hz)
2.4-2.4835GHz	-	-	-	-	-
BT-LE(125kbps)	717.391k	1.075M	1M08F1D	605.072k	1.071M
BT-LE(500kbps)	699.275k	1.038M	1M04F1D	666.667k	1.031M
BT-LE(1Mbps)	692.029k	1.046M	1M05F1D	670.29k	1.038M
BT-LE(2Mbps)	1.246M	2.048M	2M05F1D	1.116M	2.041M

Max-N dB = Maximum 6dB down bandwidth; Max-OBW = Maximum 99% occupied bandwidth;
Min-N dB = Minimum 6dB down bandwidth; Min-OBW = Minimum 99% occupied bandwidth



Result

Mode	Result	Limit (Hz)	Port 1-N dB (Hz)	Port 1-OBW (Hz)
BT-LE(125kbps)	-	-	-	-
2402MHz	Pass	500k	605.072k	1.075M
2440MHz	Pass	500k	706.522k	1.071M
2480MHz	Pass	500k	717.391k	1.071M
BT-LE(500kbps)	-	-	-	-
2402MHz	Pass	500k	666.667k	1.038M
2440MHz	Pass	500k	699.275k	1.031M
2480MHz	Pass	500k	677.536k	1.038M
BT-LE(1Mbps)	-	-	-	-
2402MHz	Pass	500k	673.913k	1.046M
2440MHz	Pass	500k	670.29k	1.038M
2480MHz	Pass	500k	692.029k	1.042M
BT-LE(2Mbps)	-	-	-	-
2402MHz	Pass	500k	1.246M	2.041M
2440MHz	Pass	500k	1.138M	2.041M
2480MHz	Pass	500k	1.116M	2.048M

Port X-N dB = Port X 6dB down bandwidth;
Port X-OBW = Port X 99% occupied bandwidth

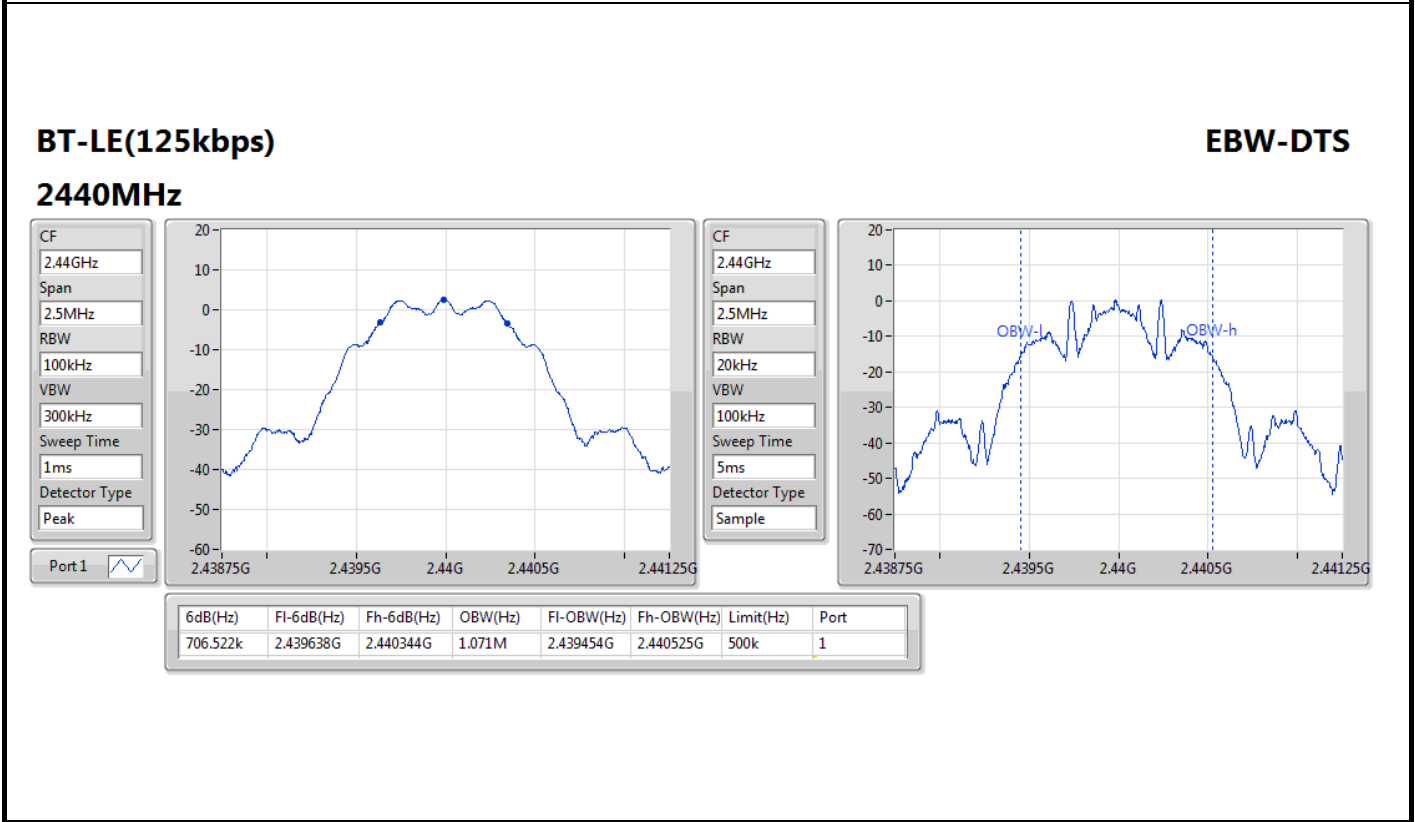
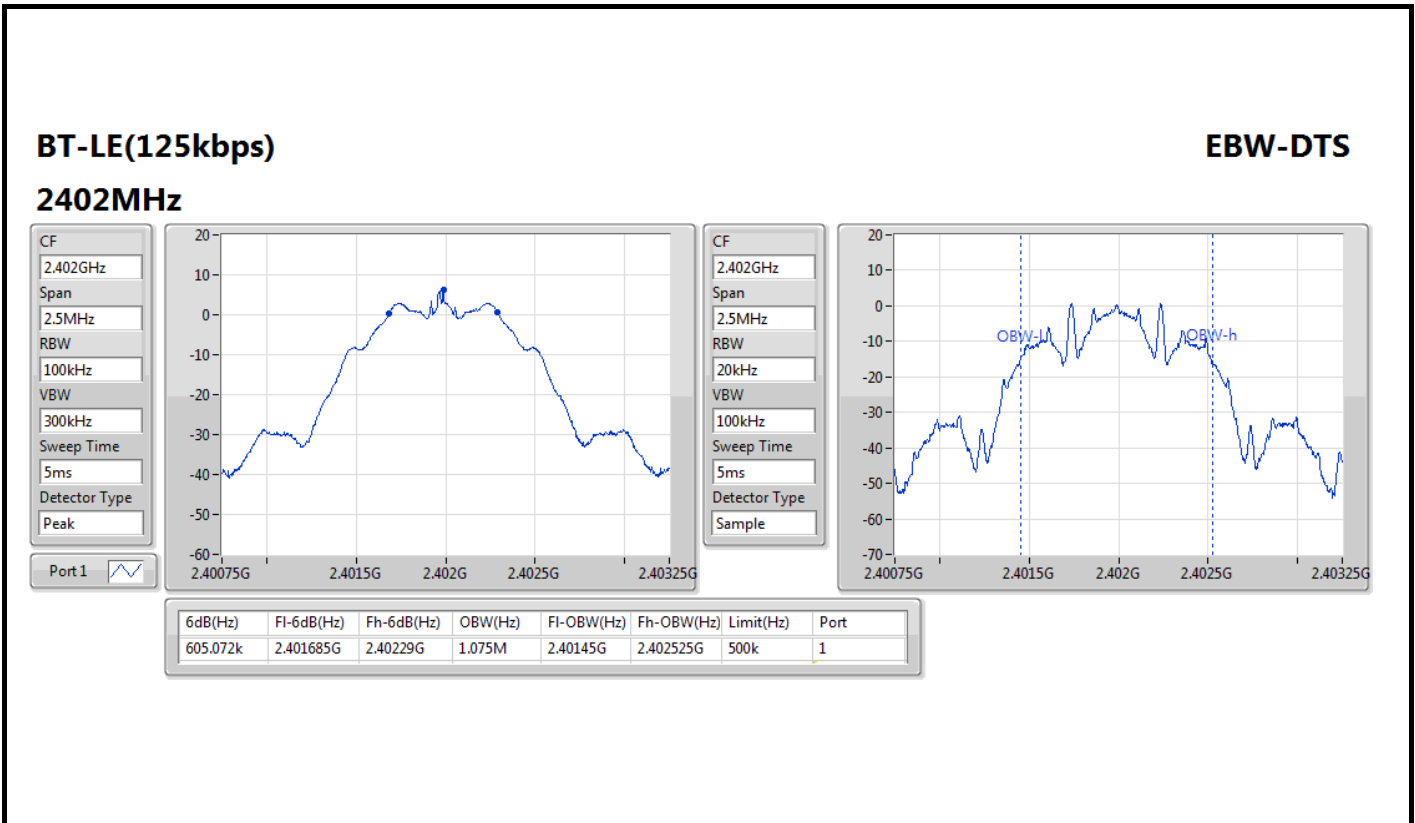

BT-LE(125kbps)

EBW-DTS

2480MHz

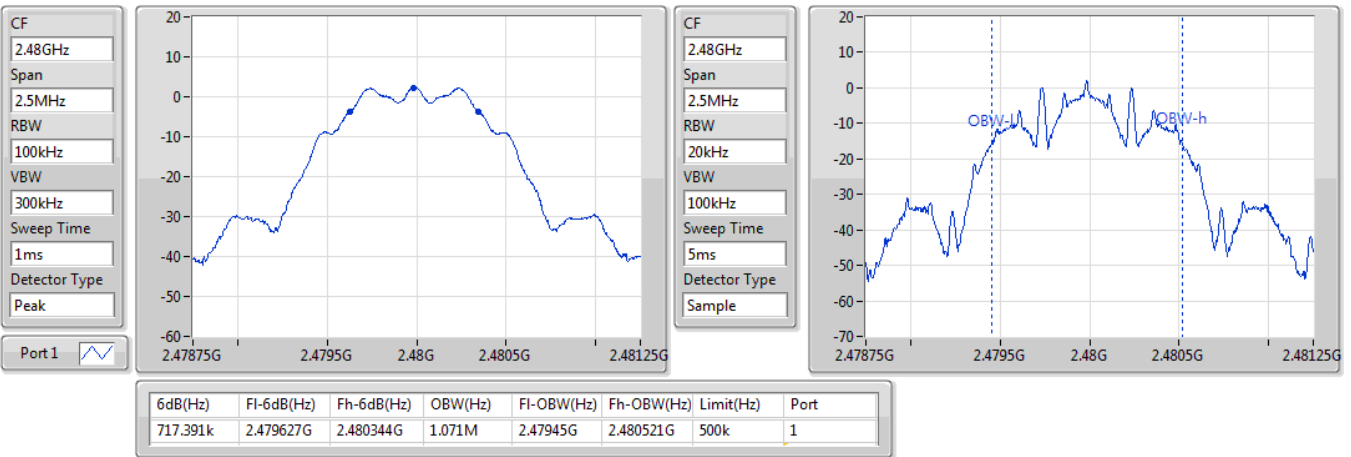

BT-LE(500kbps)

EBW-DTS

2402MHz

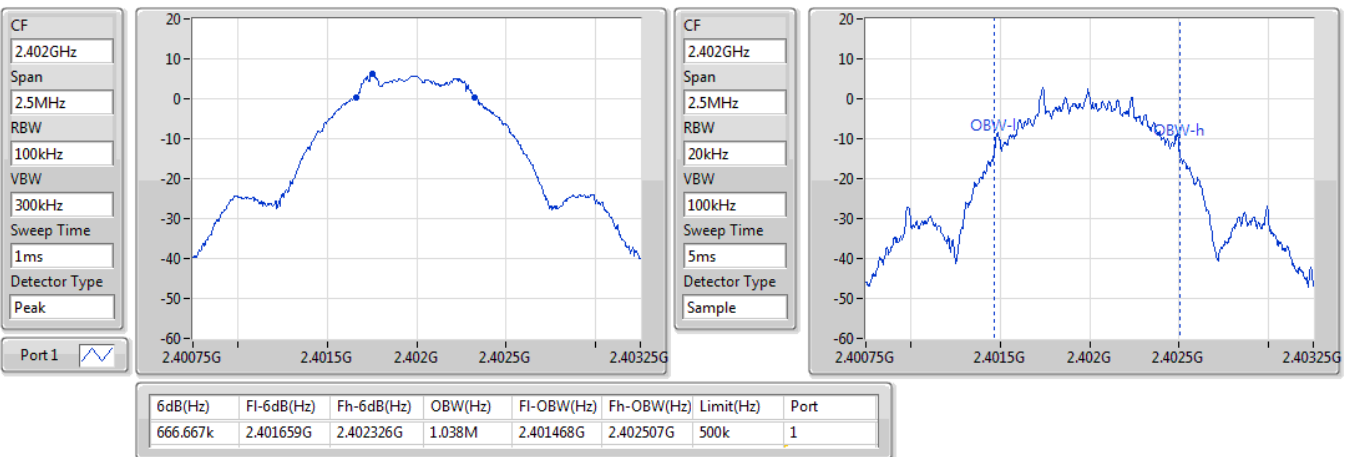



BT-LE(500kbps)

EBW-DTS

2440MHz

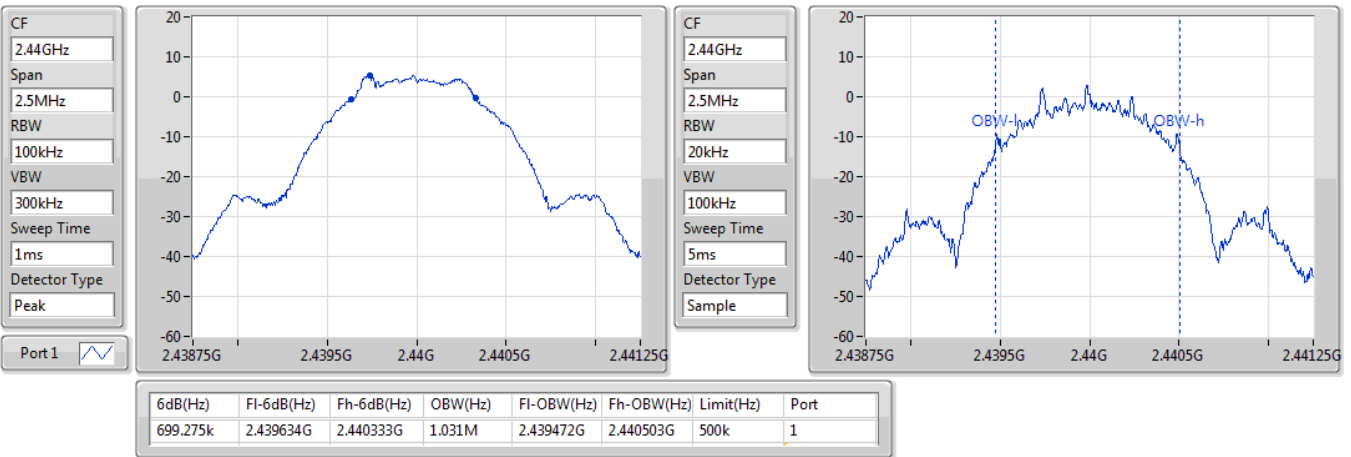

BT-LE(500kbps)

EBW-DTS

2480MHz

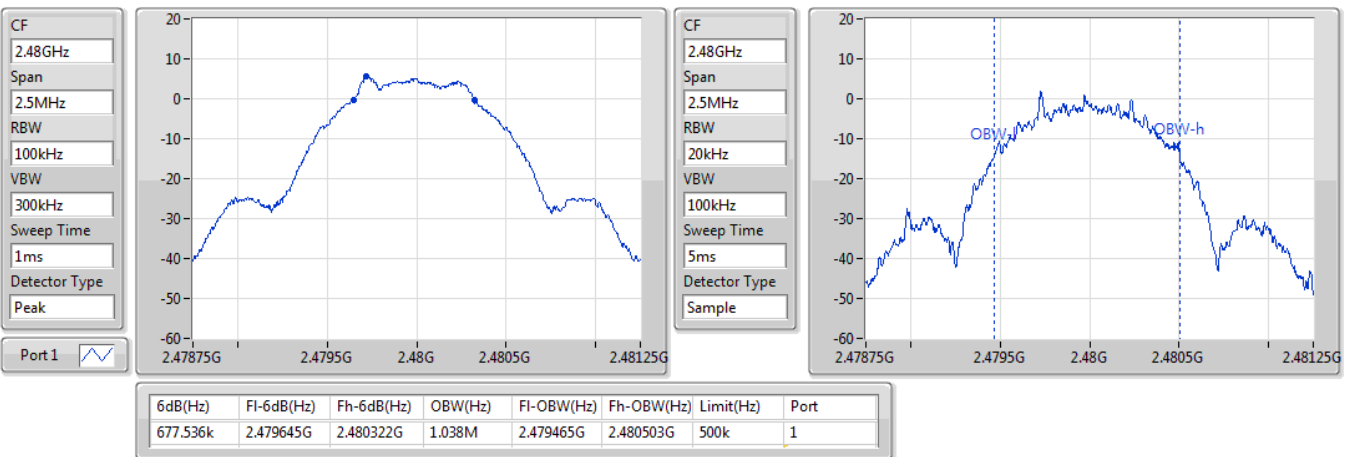



BT-LE(1Mbps)

EBW-DTS

2402MHz

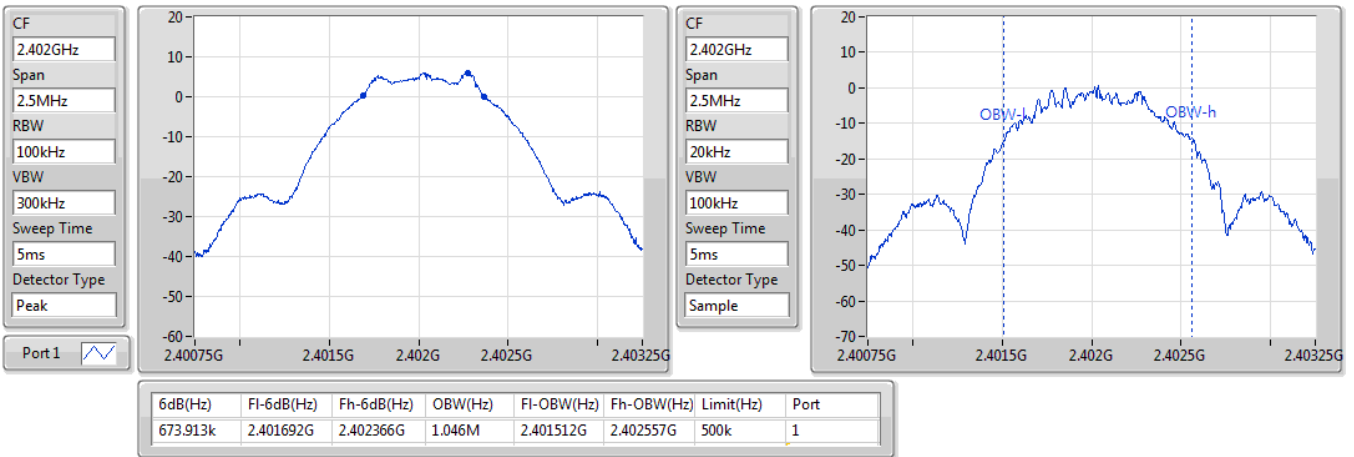

BT-LE(1Mbps)

EBW-DTS

2440MHz

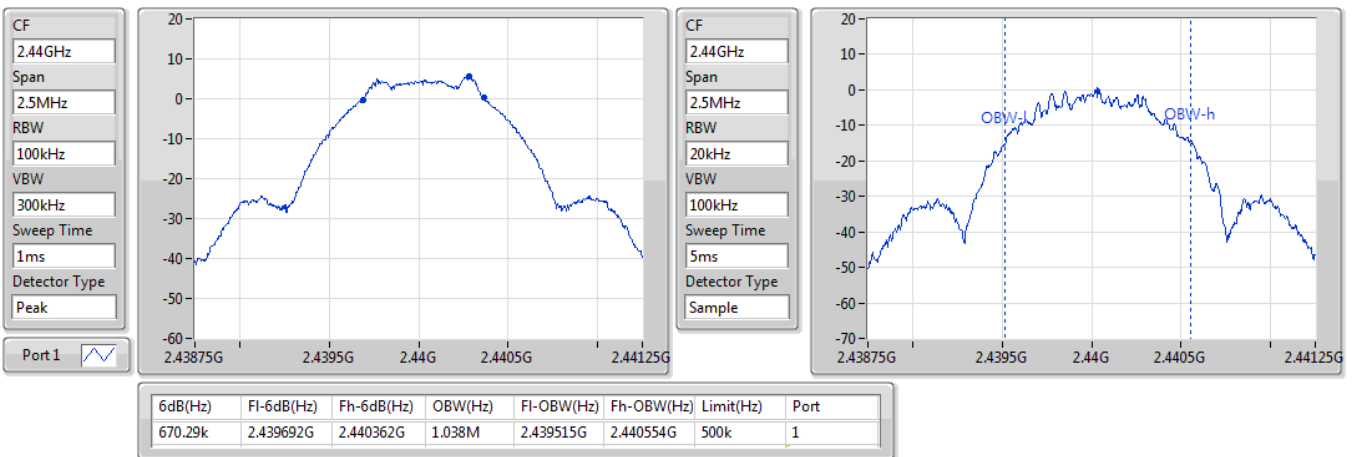



BT-LE(1Mbps)

EBW-DTS

2480MHz

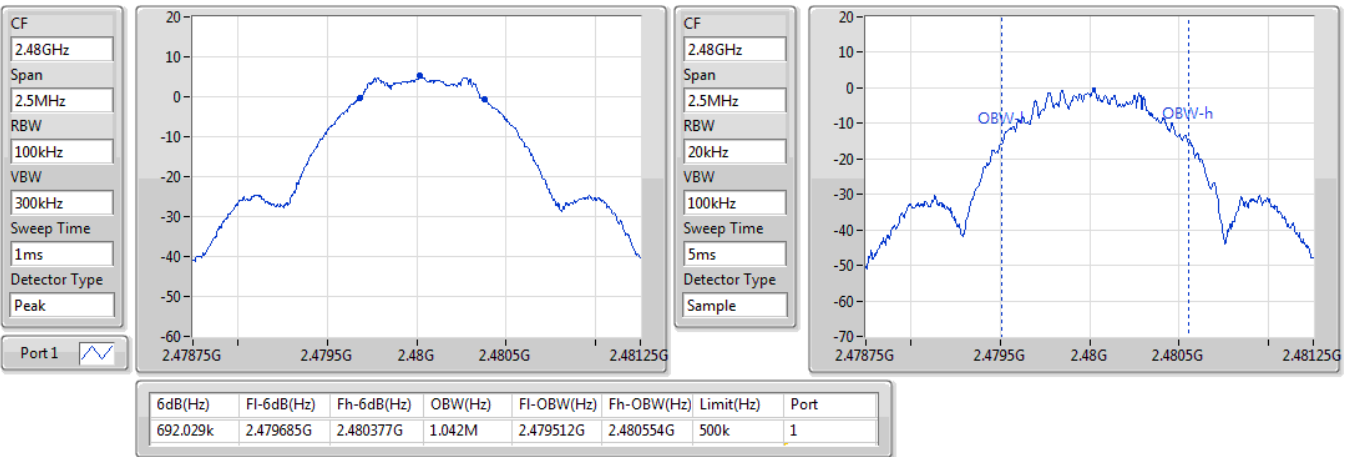

BT-LE(2Mbps)

EBW-DTS

2402MHz

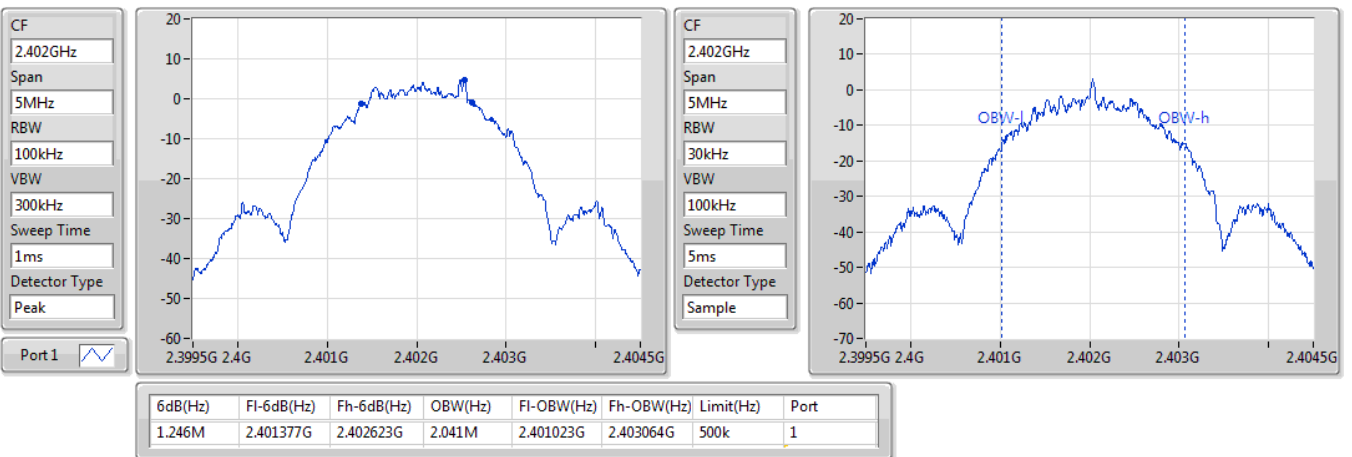

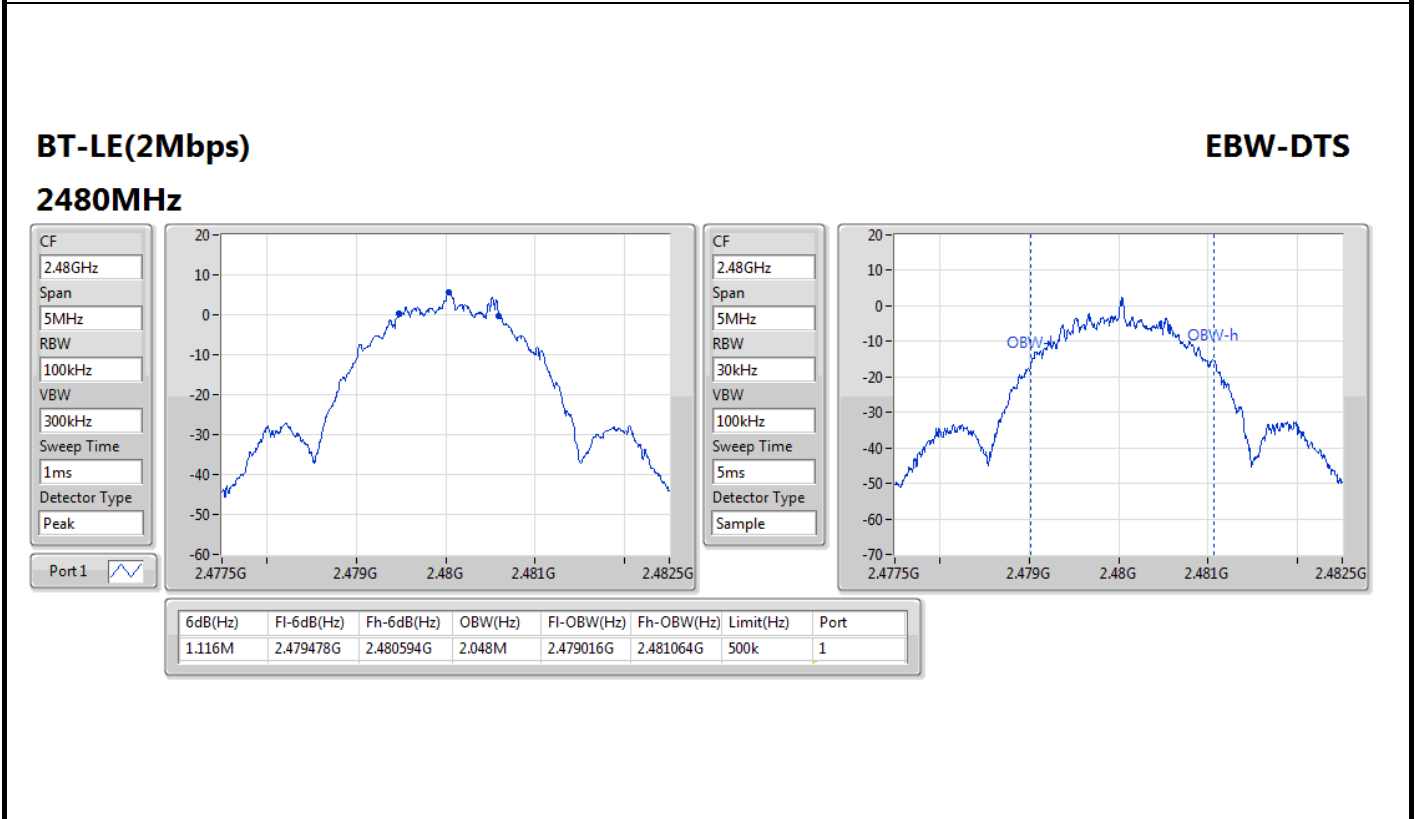
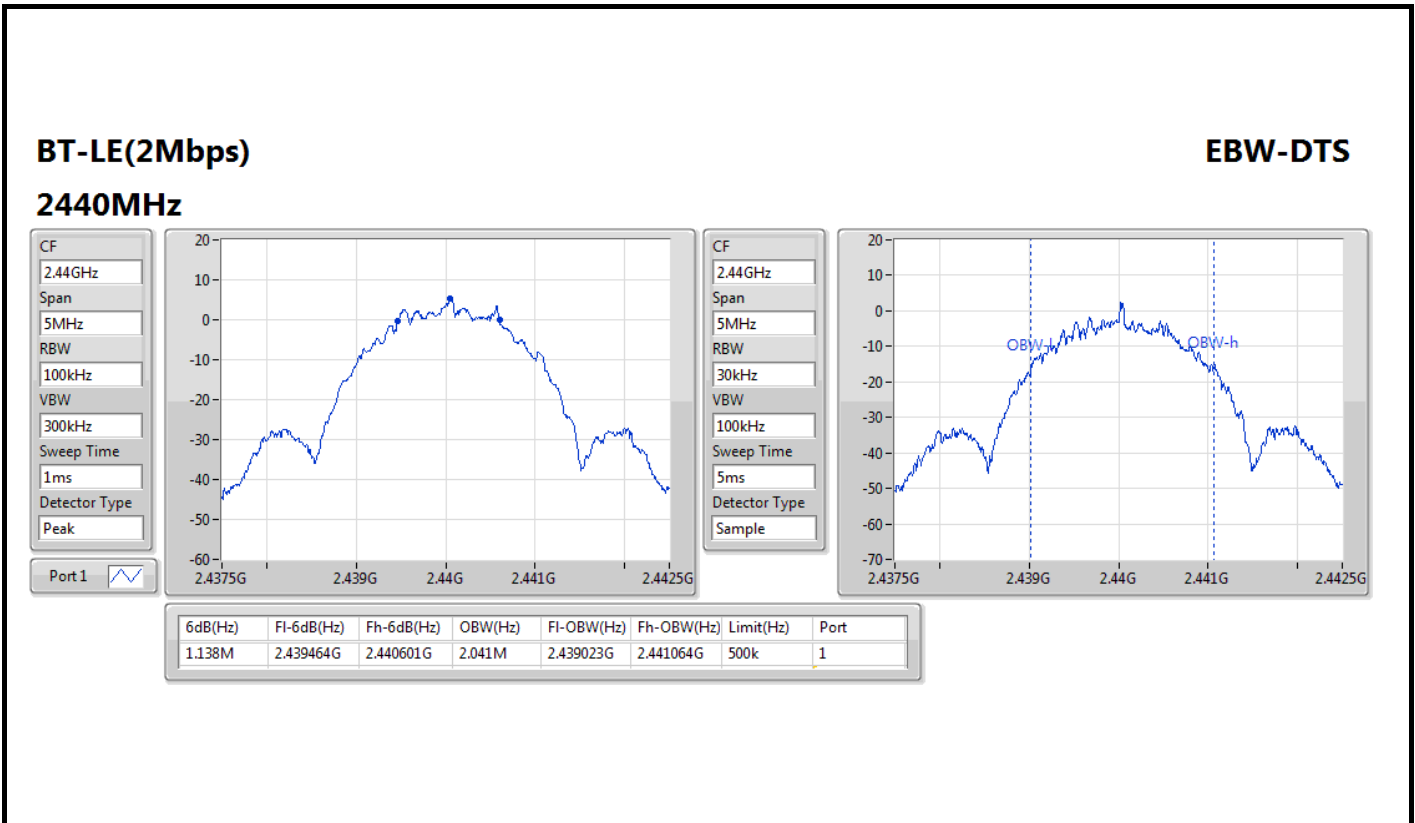



Conducted Output Power (Average)

Appendix B

Summary

Mode	Power (dBm)	Power (W)
2.4-2.4835GHz	-	-
BT-LE(125kbps)	6.51	0.00448
BT-LE(500kbps)	6.55	0.00452
BT-LE(1Mbps)	6.57	0.00454
BT-LE(2Mbps)	6.56	0.00453

Result

Mode	Result	Antenna Gain (dBi)	Power (dBm)	Power Limit (dBm)
BT-LE(125kbps)	-	-	-	-
2402MHz	Pass	2.68	6.51	-
2440MHz	Pass	2.68	6.09	-
2480MHz	Pass	2.68	6.02	-
BT-LE(500kbps)	-	-	-	-
2402MHz	Pass	2.68	6.55	-
2440MHz	Pass	2.68	6.09	-
2480MHz	Pass	2.68	6.02	-
BT-LE(1Mbps)	-	-	-	-
2402MHz	Pass	2.68	6.57	-
2440MHz	Pass	2.68	6.12	-
2480MHz	Pass	2.68	6.03	-
BT-LE(2Mbps)	-	-	-	-
2402MHz	Pass	2.68	6.56	-
2440MHz	Pass	2.68	6.10	-
2480MHz	Pass	2.68	6.02	-

Note: Average power is for reference only.



Summary

Mode	Power (dBm)	Power (W)
2.4-2.4835GHz	-	-
BT-LE(125kbps)	6.65	0.00462
BT-LE(500kbps)	6.65	0.00462
BT-LE(1Mbps)	6.67	0.00465
BT-LE(2Mbps)	6.66	0.00463

Result

Mode	Result	Antenna Gain (dBi)	Power (dBm)	Power Limit (dBm)
BT-LE(125kbps)	-	-	-	-
2402MHz	Pass	2.68	6.65	30.00
2440MHz	Pass	2.68	6.21	30.00
2480MHz	Pass	2.68	6.12	30.00
BT-LE(500kbps)	-	-	-	-
2402MHz	Pass	2.68	6.65	30.00
2440MHz	Pass	2.68	6.21	30.00
2480MHz	Pass	2.68	6.12	30.00
BT-LE(1Mbps)	-	-	-	-
2402MHz	Pass	2.68	6.67	30.00
2440MHz	Pass	2.68	6.23	30.00
2480MHz	Pass	2.68	6.14	30.00
BT-LE(2Mbps)	-	-	-	-
2402MHz	Pass	2.68	6.66	30.00
2440MHz	Pass	2.68	6.22	30.00
2480MHz	Pass	2.68	6.13	30.00



Summary

Mode	PD (dBm/3kHz)
2.4-2.4835GHz	-
BT-LE(125kbps)	0.41
BT-LE(500kbps)	0.06
BT-LE(1Mbps)	-10.15
BT-LE(2Mbps)	-11.41

Result

Mode	Result	Antenna Gain (dBi)	Power Density (dBm/3kHz)	Power Density Limit (dBm/3kHz)
BT-LE(125kbps)	-	-	-	-
2402MHz	Pass	2.68	0.41	8.00
2440MHz	Pass	2.68	-0.04	8.00
2480MHz	Pass	2.68	-0.20	8.00
BT-LE(500kbps)	-	-	-	-
2402MHz	Pass	2.68	0.06	8.00
2440MHz	Pass	2.68	-0.32	8.00
2480MHz	Pass	2.68	-0.44	8.00
BT-LE(1Mbps)	-	-	-	-
2402MHz	Pass	2.68	-10.15	8.00
2440MHz	Pass	2.68	-10.79	8.00
2480MHz	Pass	2.68	-10.83	8.00
BT-LE(2Mbps)	-	-	-	-
2402MHz	Pass	2.68	-11.41	8.00
2440MHz	Pass	2.68	-11.94	8.00
2480MHz	Pass	2.68	-11.71	8.00



BT-LE(125kbps)

PSD

2402MHz

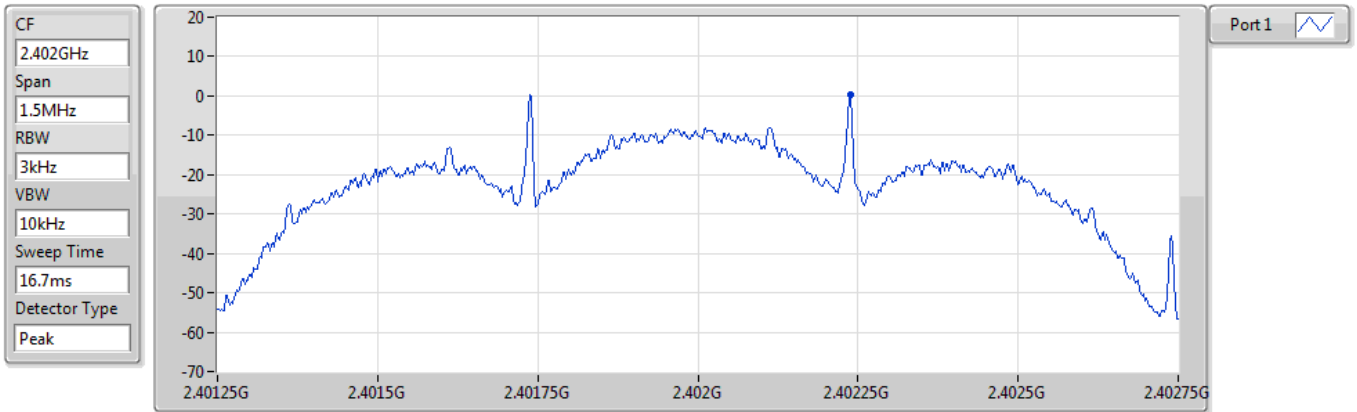

Sum	PD	Port 1
(dBm/RBW)	(dBm/RBW)	(dBm/RBW)
0.41	0.41	0.41

BT-LE(125kbps)

PSD

2440MHz

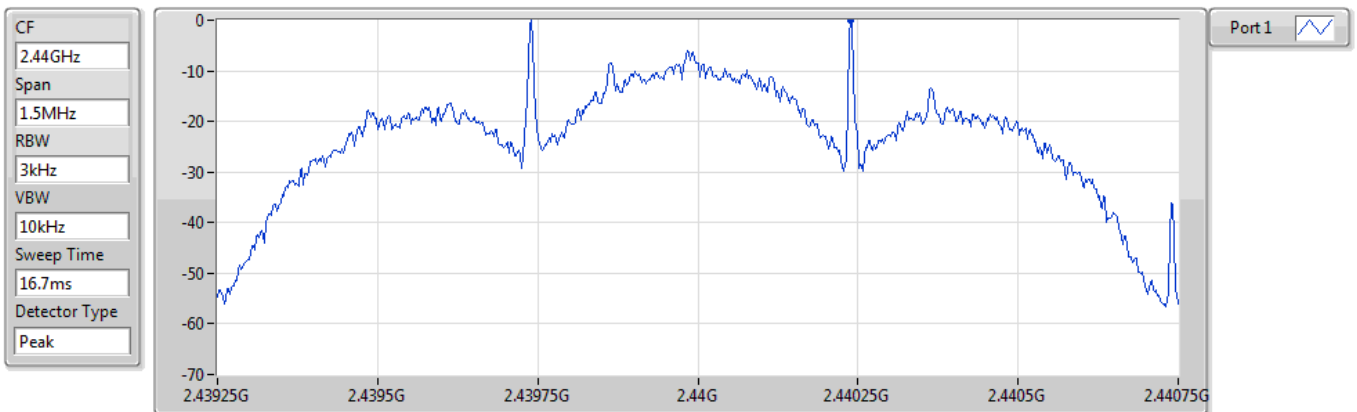

Sum	PD	Port 1
(dBm/RBW)	(dBm/RBW)	(dBm/RBW)
-0.04	-0.04	-0.04



BT-LE(125kbps)

PSD

2480MHz

CF
2.48GHz
Span
1.5MHz
RBW
3kHz
VBW
10kHz
Sweep Time
16.7ms
Detector Type
Peak

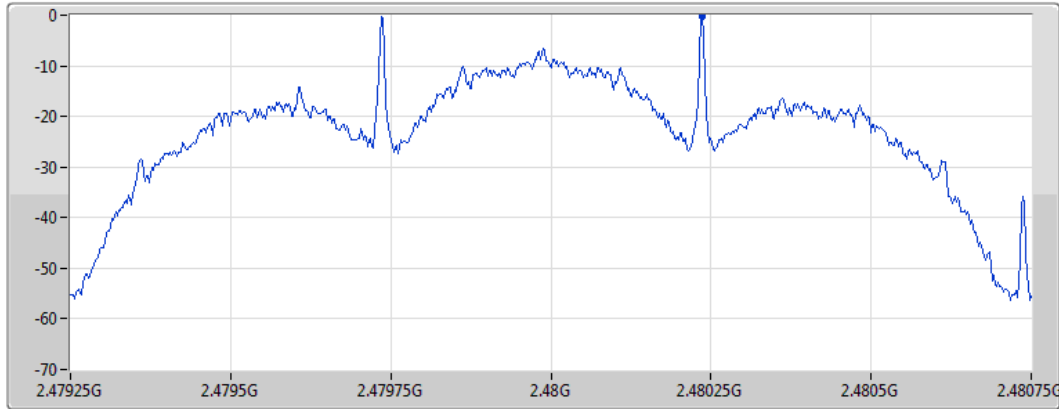

Port 1

Sum	PD	Port 1
(dBm/RBW)	(dBm/RBW)	(dBm/RBW)
-0.20	-0.20	-0.20

BT-LE(500kbps)

PSD

2402MHz

CF
2.402GHz
Span
1.5MHz
RBW
3kHz
VBW
10kHz
Sweep Time
16.7ms
Detector Type
Peak

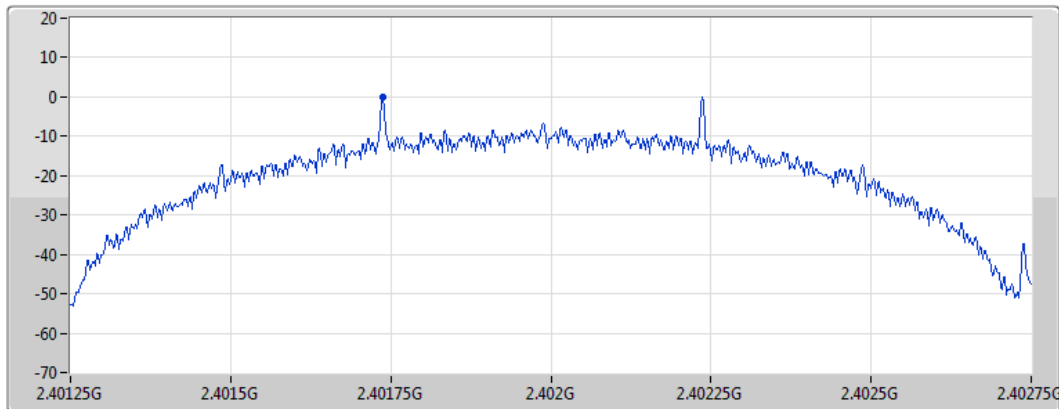

Port 1

Sum	PD	Port 1
(dBm/RBW)	(dBm/RBW)	(dBm/RBW)
0.06	0.06	0.06



BT-LE(500kbps)

PSD

2440MHz

CF
2.44GHz
Span
1.5MHz
RBW
3kHz
VBW
10kHz
Sweep Time
16.7ms
Detector Type
Peak

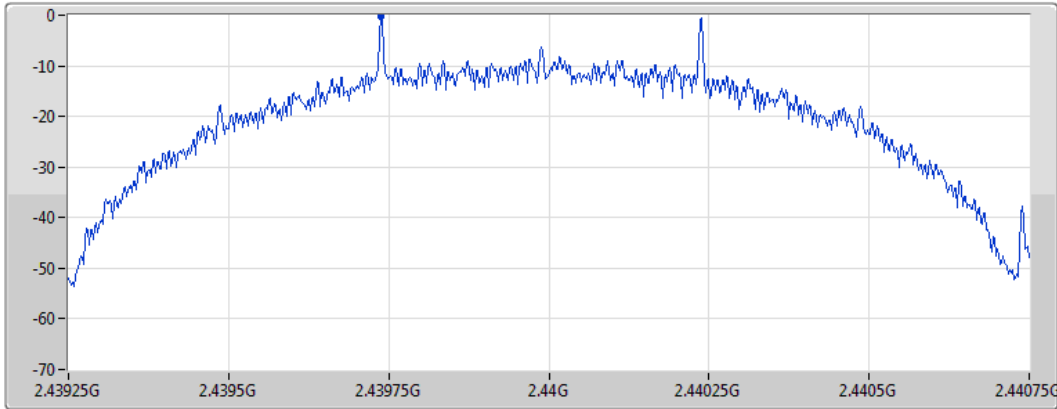

Port 1

Sum	PD	Port 1
(dBm/RBW)	(dBm/RBW)	(dBm/RBW)
-0.32	-0.32	-0.32

BT-LE(500kbps)

PSD

2480MHz

CF
2.48GHz
Span
1.5MHz
RBW
3kHz
VBW
10kHz
Sweep Time
16.7ms
Detector Type
Peak

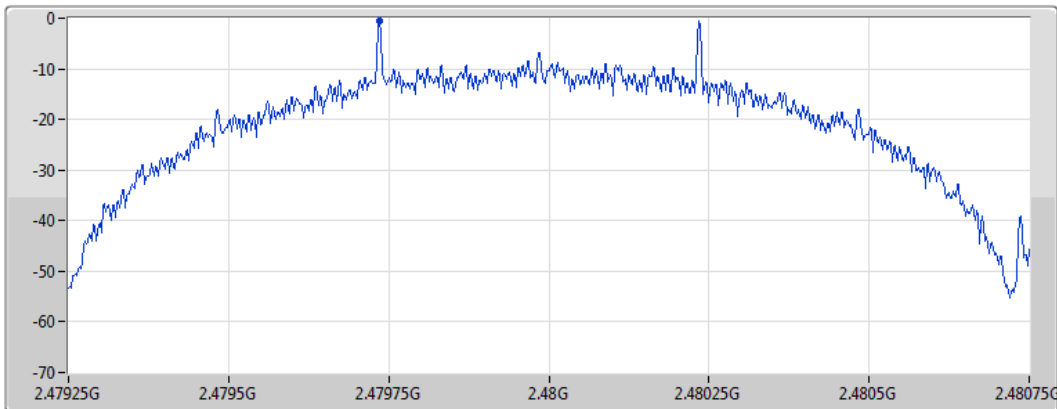

Port 1

Sum	PD	Port 1
(dBm/RBW)	(dBm/RBW)	(dBm/RBW)
-0.44	-0.44	-0.44



BT-LE(1Mbps)

PSD

2402MHz

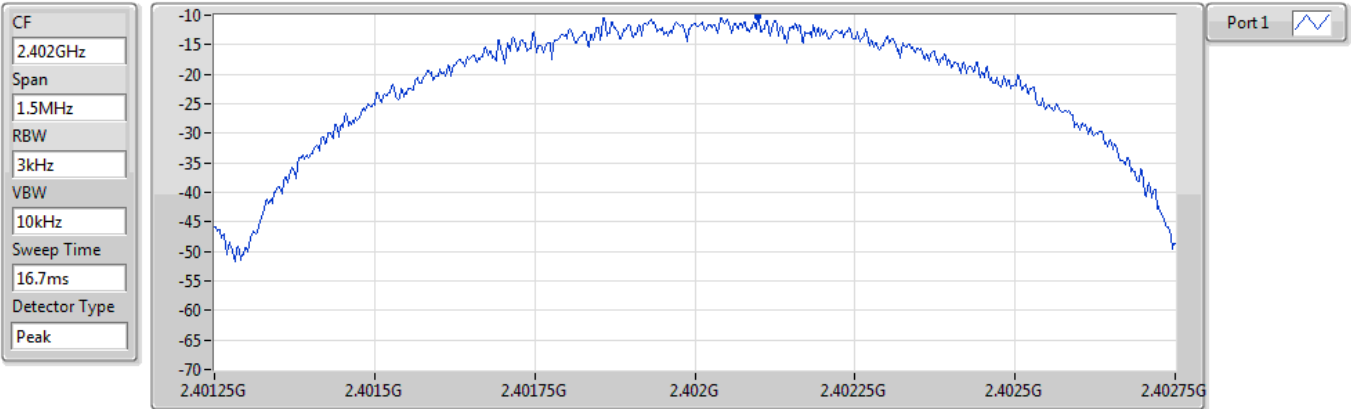

Sum	PD	Port 1
(dBm/RBW)	(dBm/RBW)	(dBm/RBW)
-10.15	-10.15	-10.15

BT-LE(1Mbps)

PSD

2440MHz

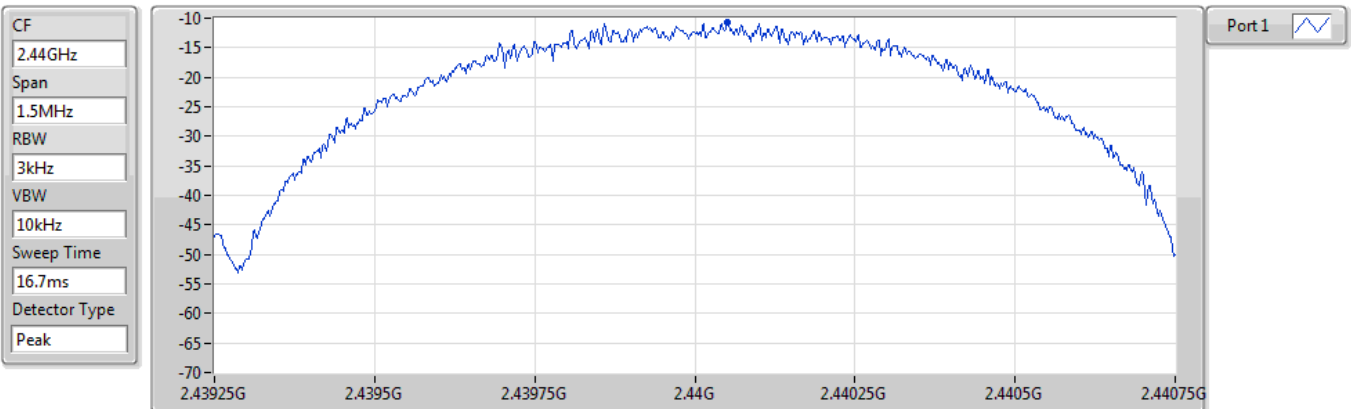

Sum	PD	Port 1
(dBm/RBW)	(dBm/RBW)	(dBm/RBW)
-10.79	-10.79	-10.79



BT-LE(1Mbps)

PSD

2480MHz

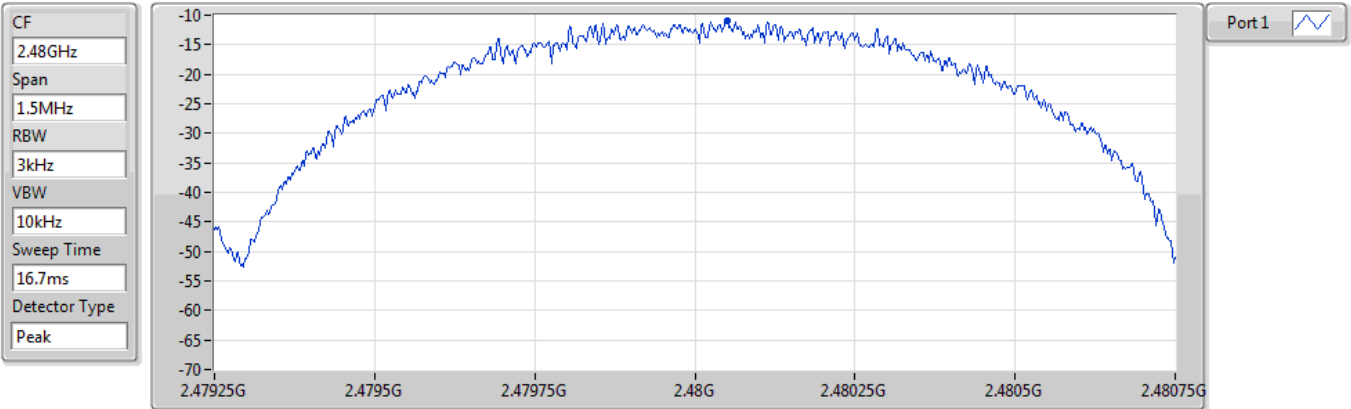

Sum	PD	Port 1
(dBm/RBW)	(dBm/RBW)	(dBm/RBW)
-10.83	-10.83	-10.83

BT-LE(2Mbps)

PSD

2402MHz

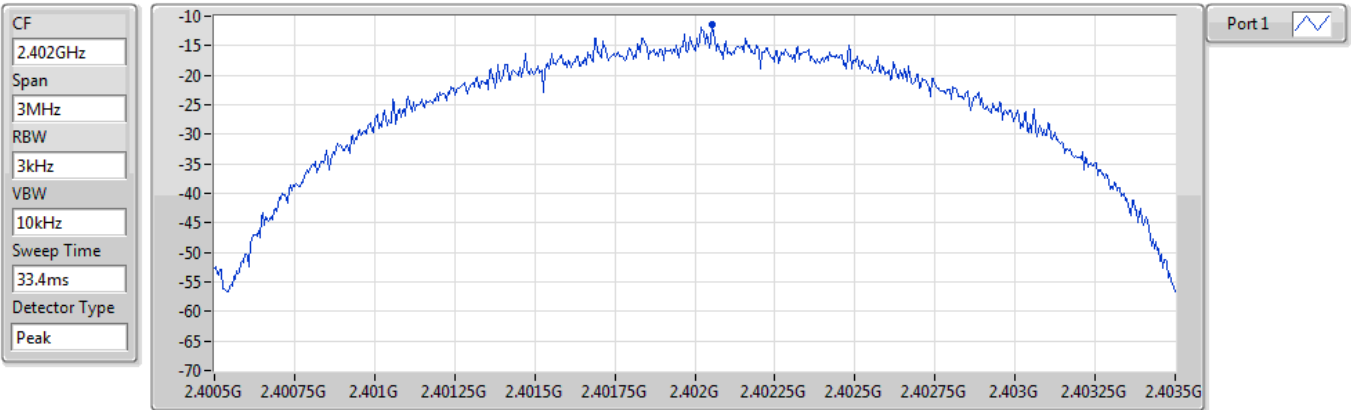

Sum	PD	Port 1
(dBm/RBW)	(dBm/RBW)	(dBm/RBW)
-11.41	-11.41	-11.41



BT-LE(2Mbps)

PSD

2440MHz

CF
2.44GHz
Span
3MHz
RBW
3kHz
VBW
10kHz
Sweep Time
33.4ms
Detector Type
Peak

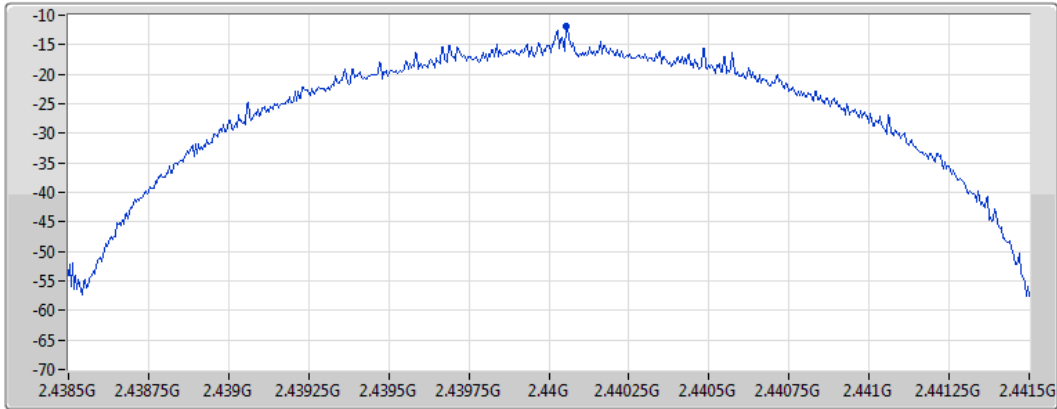

Port 1

Sum	PD	Port 1
(dBm/RBW)	(dBm/RBW)	(dBm/RBW)
-11.94	-11.94	-11.94

BT-LE(2Mbps)

PSD

2480MHz

CF
2.48GHz
Span
3MHz
RBW
3kHz
VBW
10kHz
Sweep Time
33.4ms
Detector Type
Peak

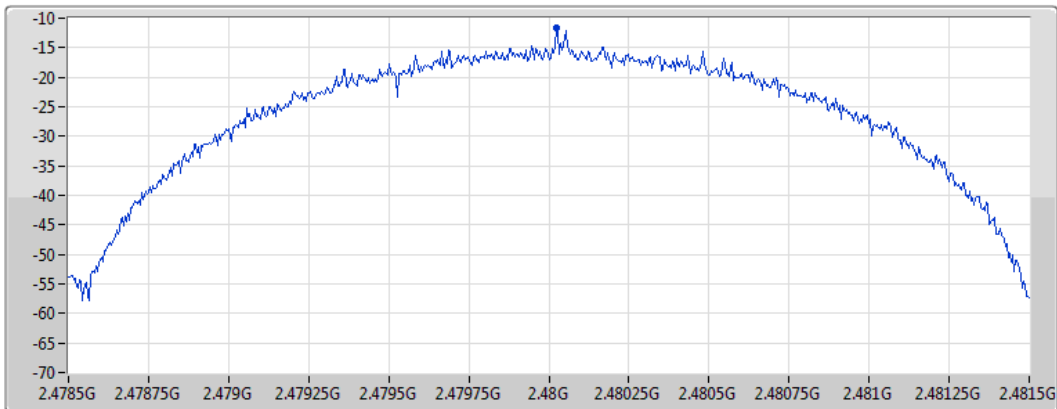

Port 1

Sum	PD	Port 1
(dBm/RBW)	(dBm/RBW)	(dBm/RBW)
-11.71	-11.71	-11.71



Unwanted Emissions (Below 1GHz)

Modulation	BT-LE (1Mbps)	Test Freq. (MHz)	2402						
Polarization	Horizontal								
Test By :Roger Lu Temperature(°C):23 Humidity(%):65									
<p>The graph plots Level (dBuV/m) on the y-axis (0 to 90) against Frequency (MHz) on the x-axis (30 to 1000). A red step function represents the CLASS-B limit. Six peaks are marked with blue vertical lines and numbered 1 through 6. Peak 1 is at 70.68 MHz, peak 2 at 167.59 MHz, peak 3 at 214.95 MHz, peak 4 at 249.67 MHz, peak 5 at 263.58 MHz, and peak 6 at 547.26 MHz. All peaks are below the CLASS-B limit.</p>									
	Freq. MHz	Emission level dBuV/m	Limit dBuV/m	Margin dB	SA reading dBuV	Factor dB/m	Remark	ANT High cm	Turn Table deg
1	70.68	35.57	40.00	-4.43	46.57	-11.00	Peak	---	---
2	167.59	38.21	43.50	-5.29	47.17	-8.96	Peak	---	---
3	214.95	32.64	43.50	-10.86	44.58	-11.94	Peak	---	---
4	249.67	35.15	46.00	-10.85	45.22	-10.07	Peak	---	---
5	263.58	37.55	46.00	-8.45	47.07	-9.52	Peak	---	---
6	547.26	33.54	46.00	-12.46	36.12	-2.58	Peak	---	---

Note 1: Emission Level (dBuV/m) = SA Reading (dBuV) + Factor* (dB/m)
 *Factor includes antenna factor , cable loss and amplifier gain
 Note 2: Margin (dB) = Emission level (dBuV/m) – Limit (dBuV/m).
 Note 3: All spurious emissions below 30MHz are more than 20 dB below the limit.



Modulation	BT-LE (1Mbps)	Test Freq. (MHz)	2402
Polarization	Vertical		

Test By : Roger Lu Temperature(°C):23 Humidity(%):65

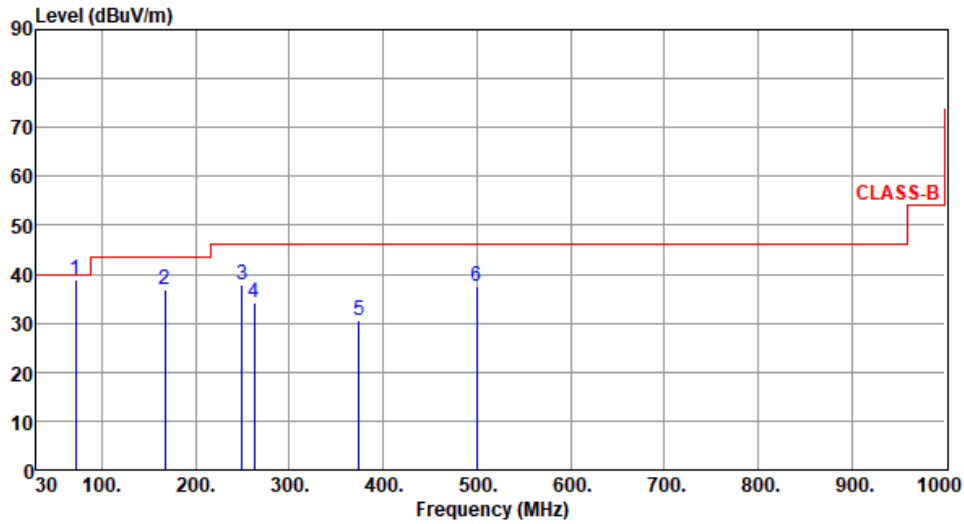

	Freq. MHz	Emission level dBuV/m	Limit dBuV/m	Margin dB	SA reading dBuV	Factor dB/m	Remark	ANT High cm	Turn Table deg
1	71.64	38.86	40.00	-1.14	50.01	-11.15	QP	125	263
2	167.54	36.81	43.50	-6.69	45.77	-8.96	Peak	---	---
3	249.58	37.86	46.00	-8.14	47.93	-10.07	Peak	---	---
4	262.91	34.15	46.00	-11.85	43.71	-9.56	Peak	---	---
5	374.58	30.55	46.00	-15.45	36.89	-6.34	Peak	---	---
6	500.15	37.45	46.00	-8.55	40.74	-3.29	Peak	---	---

Note 1: Emission Level (dBuV/m) = SA Reading (dBuV) + Factor* (dB/m)

*Factor includes antenna factor , cable loss and amplifier gain

Note 2: Margin (dB) = Emission level (dBuV/m) – Limit (dBuV/m).

Note 3: All spurious emissions below 30MHz are more than 20 dB below the limit.



Unwanted Emissions (Above 1GHz)

Modulation	BT-LE (1Mbps)	Test Freq. (MHz)	2402
Polarization	Horizontal		

Test By : Roger Lu Temperature(°C):23 Humidity(%):65

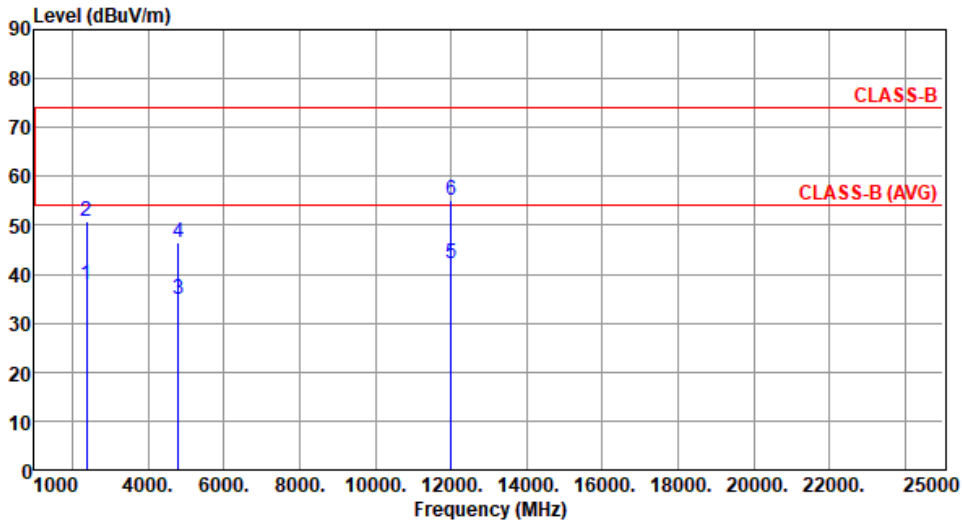

	Freq. MHz	Emission level dBuV/m	Limit dBuV/m	Margin dB	SA reading dBuV	Factor dB/m	Remark	ANT High cm	Turn Table deg
1	2390.00	37.81	54.00	-16.19	40.56	-2.75	Average	204	234
2	2390.00	50.84	74.00	-23.16	53.59	-2.75	Peak	204	234
3	4804.00	35.02	54.00	-18.98	30.89	4.13	Average	265	135
4	4804.00	46.52	74.00	-27.48	42.39	4.13	Peak	265	135
5	12010.00	42.07	54.00	-11.93	28.45	13.62	Average	100	50
6	12010.00	55.20	74.00	-18.80	41.58	13.62	Peak	100	50

Note 1: Emission Level (dBuV/m) = SA Reading (dBuV) + Factor* (dB/m)

*Factor includes antenna factor , cable loss and amplifier gain

Note 2: Margin (dB) = Emission level (dBuV/m) – Limit (dBuV/m).



Modulation	BT-LE (1Mbps)	Test Freq. (MHz)	2402
Polarization	Vertical		

Test By : Roger Lu Temperature(°C):23 Humidity(%):65

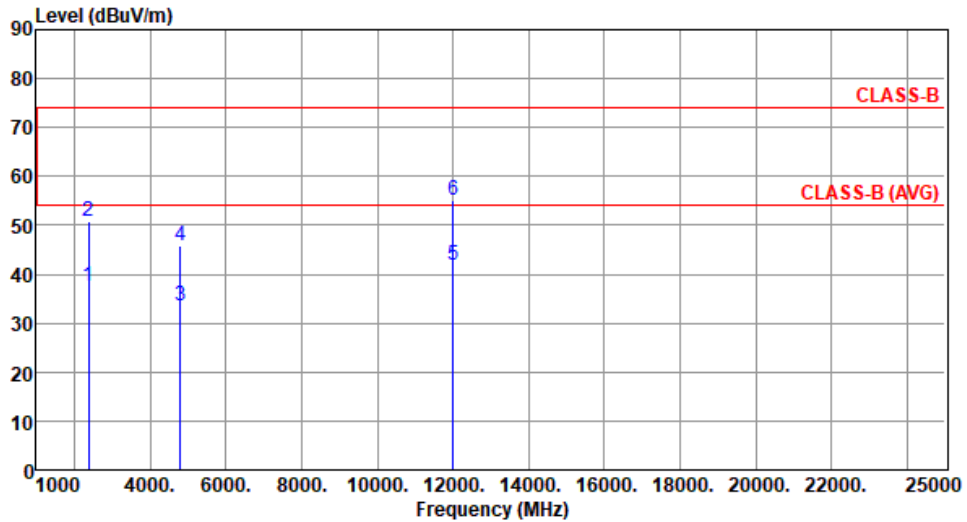

	Freq. MHz	Emission level dBuV/m	Limit dBuV/m	Margin dB	SA reading dBuV	Factor dB/m	Remark	ANT High cm	Turn Table deg
1	2390.00	37.37	54.00	-16.63	40.12	-2.75	Average	326	257
2	2390.00	50.67	74.00	-23.33	53.42	-2.75	Peak	326	257
3	4804.00	33.38	54.00	-20.62	29.25	4.13	Average	100	178
4	4804.00	45.69	74.00	-28.31	41.56	4.13	Peak	100	178
5	12010.00	41.87	54.00	-12.13	28.25	13.62	Average	100	30
6	12010.00	55.04	74.00	-18.96	41.42	13.62	Peak	100	30

Note 1: Emission Level (dBuV/m) = SA Reading (dBuV) + Factor* (dB/m)

*Factor includes antenna factor , cable loss and amplifier gain

Note 2: Margin (dB) = Emission level (dBuV/m) – Limit (dBuV/m).



Modulation	BT-LE (1Mbps)	Test Freq. (MHz)	2440
Polarization	Horizontal		

Test By : Roger Lu Temperature(°C):23 Humidity(%):65

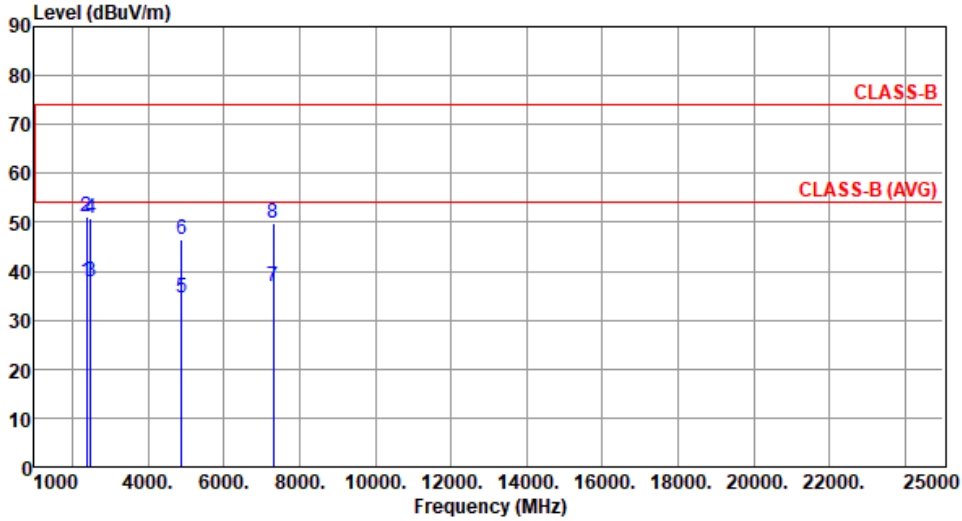

	Freq. MHz	Emission level dBuV/m	Limit dBuV/m	Margin dB	SA reading dBuV	Factor dB/m	Remark	ANT High cm	Turn Table deg
1	2390.00	37.84	54.00	-16.16	40.59	-2.75	Average	206	232
2	2390.00	51.03	74.00	-22.97	53.78	-2.75	Peak	206	232
3	2483.50	37.72	54.00	-16.28	40.42	-2.70	Average	206	232
4	2483.50	50.95	74.00	-23.05	53.65	-2.70	Peak	206	232
5	4880.00	34.69	54.00	-19.31	30.57	4.12	Average	268	134
6	4880.00	46.55	74.00	-27.45	42.43	4.12	Peak	268	134
7	7320.00	36.96	54.00	-17.04	27.68	9.28	Average	100	50
8	7320.00	49.83	74.00	-24.17	40.55	9.28	Peak	100	50

Note 1: Emission Level (dBuV/m) = SA Reading (dBuV) + Factor* (dB/m)

*Factor includes antenna factor , cable loss and amplifier gain

Note 2: Margin (dB) = Emission level (dBuV/m) – Limit (dBuV/m).



Modulation	BT-LE (1Mbps)	Test Freq. (MHz)	2440
Polarization	Vertical		

Test By : Roger Lu Temperature(°C):23 Humidity(%):65

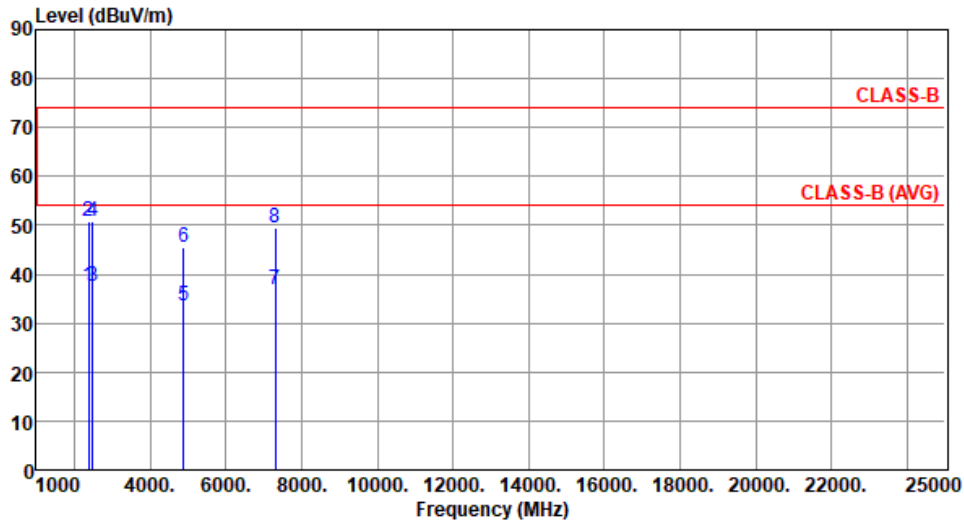

	Freq. MHz	Emission level dBuV/m	Limit dBuV/m	Margin dB	SA reading dBuV	Factor dB/m	Remark	ANT High cm	Turn Table deg
1	2390.00	37.40	54.00	-16.60	40.15	-2.75	Average	331	232
2	2390.00	50.90	74.00	-23.10	53.65	-2.75	Peak	331	232
3	2483.50	37.59	54.00	-16.41	40.29	-2.70	Average	331	232
4	2483.50	50.78	74.00	-23.22	53.48	-2.70	Peak	331	232
5	4880.00	33.59	54.00	-20.41	29.47	4.12	Average	100	180
6	4880.00	45.50	74.00	-28.50	41.38	4.12	Peak	100	180
7	7320.00	36.73	54.00	-17.27	27.45	9.28	Average	100	60
8	7320.00	49.43	74.00	-24.57	40.15	9.28	Peak	100	60

Note 1: Emission Level (dBuV/m) = SA Reading (dBuV) + Factor* (dB/m)

*Factor includes antenna factor , cable loss and amplifier gain

Note 2: Margin (dB) = Emission level (dBuV/m) – Limit (dBuV/m).



Modulation	BT-LE (1Mbps)	Test Freq. (MHz)	2480
Polarization	Horizontal		

Test By : Roger Lu Temperature(°C):23 Humidity(%):65

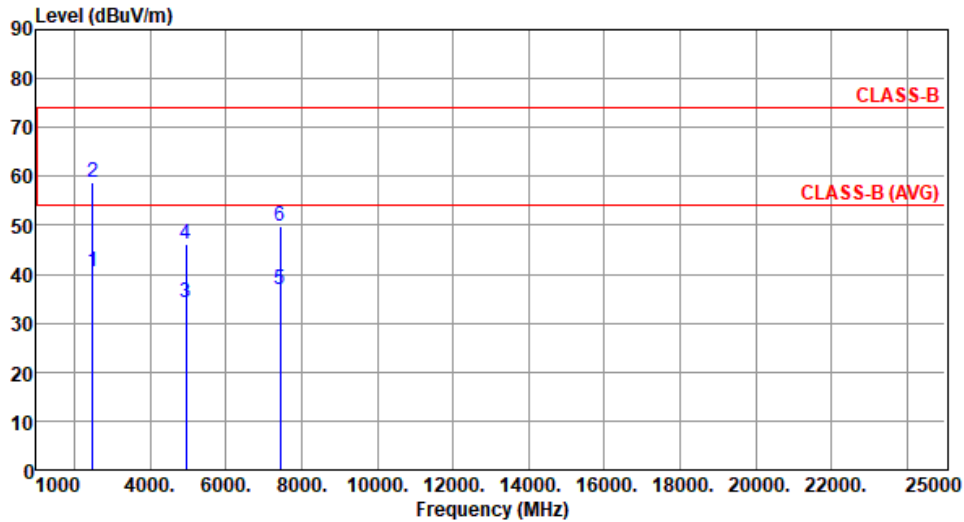

	Freq. MHz	Emission level dBuV/m	Limit dBuV/m	Margin dB	SA reading dBuV	Factor dB/m	Remark	ANT High cm	Turn Table deg
1	2483.50	40.35	54.00	-13.65	43.05	-2.70	Average	209	235
2	2483.50	58.74	74.00	-15.26	61.44	-2.70	Peak	209	235
3	4960.00	34.15	54.00	-19.85	30.12	4.03	Average	265	135
4	4960.00	46.25	74.00	-27.75	42.22	4.03	Peak	265	135
5	7440.00	36.83	54.00	-17.17	27.46	9.37	Average	100	30
6	7440.00	49.86	74.00	-24.14	40.49	9.37	Peak	100	30

Note 1: Emission Level (dBuV/m) = SA Reading (dBuV) + Factor* (dB/m)

*Factor includes antenna factor , cable loss and amplifier gain

Note 2: Margin (dB) = Emission level (dBuV/m) – Limit (dBuV/m).



Modulation	BT-LE (1Mbps)	Test Freq. (MHz)	2480
Polarization	Vertical		

Test By : Roger Lu Temperature(°C):23 Humidity(%):65

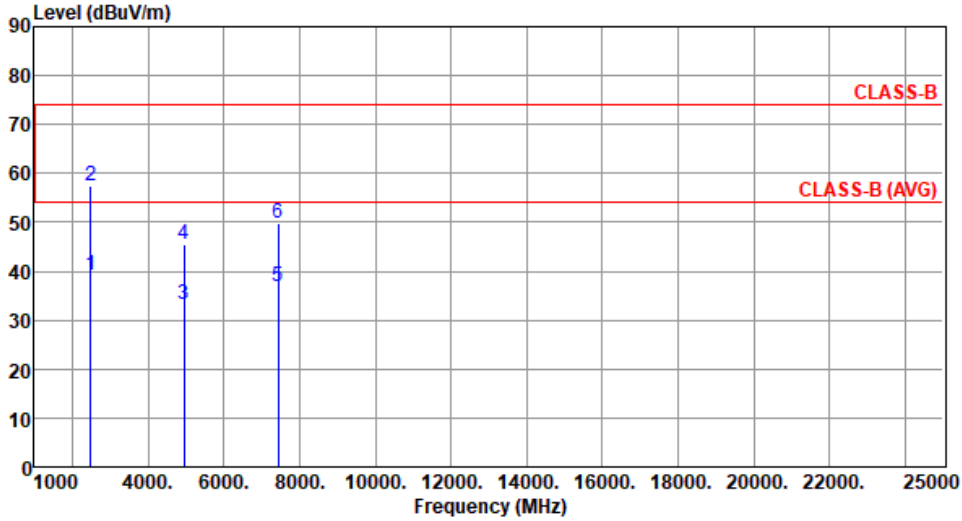

	Freq. MHz	Emission level dBuV/m	Limit dBuV/m	Margin dB	SA reading dBuV	Factor dB/m	Remark	ANT High cm	Turn Table deg
1	2483.50	39.32	54.00	-14.68	42.02	-2.70	Average	332	258
2	2483.50	57.45	74.00	-16.55	60.15	-2.70	Peak	332	258
3	4960.00	33.08	54.00	-20.92	29.05	4.03	Average	100	177
4	4960.00	45.41	74.00	-28.59	41.38	4.03	Peak	100	177
5	7440.00	36.76	54.00	-17.24	27.39	9.37	Average	100	100
6	7440.00	49.76	74.00	-24.24	40.39	9.37	Peak	100	100

Note 1: Emission Level (dBuV/m) = SA Reading (dBuV) + Factor* (dB/m)

*Factor includes antenna factor , cable loss and amplifier gain

Note 2: Margin (dB) = Emission level (dBuV/m) – Limit (dBuV/m).



Modulation	BT-LE (2Mbps)	Test Freq. (MHz)	2402						
Polarization	Horizontal								
Test By : Roger Lu		Temperature(°C): 23		Humidity(%): 65					
	Freq. MHz	Emission level dBuV/m	Limit dBuV/m	Margin dB	SA reading dBuV	Factor dB/m	Remark	ANT High cm	Turn Table deg
1	2390.00	39.31	54.00	-14.69	42.06	-2.75	Average	207	233
2	2390.00	50.73	74.00	-23.27	53.48	-2.75	Peak	207	233
3	4804.00	34.28	54.00	-19.72	30.15	4.13	Average	255	135
4	4804.00	46.16	74.00	-27.84	42.03	4.13	Peak	255	135
5	12010.00	41.85	54.00	-12.15	28.23	13.62	Average	100	30
6	12010.00	54.79	74.00	-19.21	41.17	13.62	Peak	100	30
<p>Note 1: Emission Level (dBuV/m) = SA Reading (dBuV) + Factor* (dB/m) *Factor includes antenna factor , cable loss and amplifier gain Note 2: Margin (dB) = Emission level (dBuV/m) – Limit (dBuV/m).</p>									



Modulation	BT-LE (2Mbps)	Test Freq. (MHz)	2402
Polarization	Vertical		

Test By : Roger Lu Temperature(°C):23 Humidity(%):65

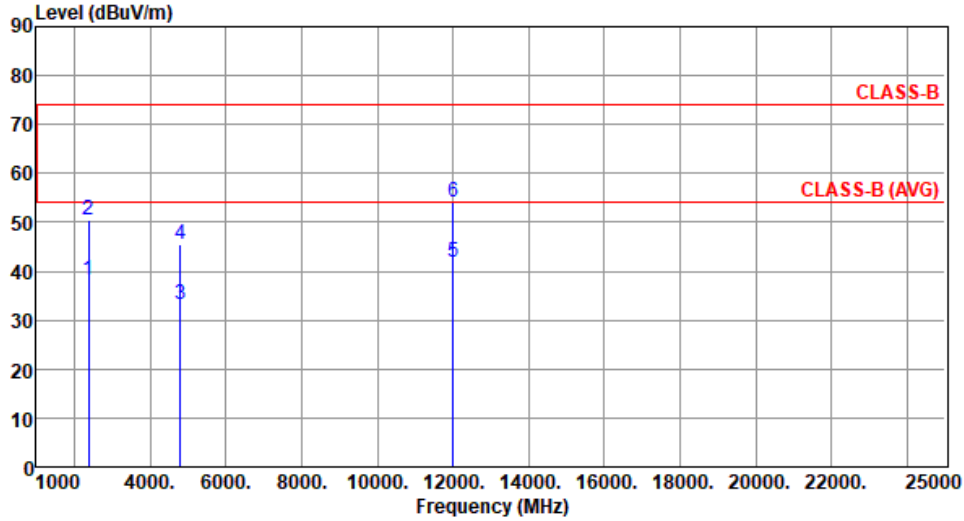

	Freq. MHz	Emission level dBuV/m	Limit dBuV/m	Margin dB	SA reading dBuV	Factor dB/m	Remark	ANT High cm	Turn Table deg
1	2390.00	38.12	54.00	-15.88	40.87	-2.75	Average	333	258
2	2390.00	50.40	74.00	-23.60	53.15	-2.75	Peak	333	258
3	4804.00	33.15	54.00	-20.85	29.02	4.13	Average	100	176
4	4804.00	45.41	74.00	-28.59	41.28	4.13	Peak	100	176
5	12010.00	41.73	54.00	-12.27	28.11	13.62	Average	100	90
6	12010.00	54.19	74.00	-19.81	40.57	13.62	Peak	100	90

Note 1: Emission Level (dBuV/m) = SA Reading (dBuV) + Factor* (dB/m)

*Factor includes antenna factor , cable loss and amplifier gain

Note 2: Margin (dB) = Emission level (dBuV/m) – Limit (dBuV/m).



Modulation	BT-LE (2Mbps)	Test Freq. (MHz)	2440
Polarization	Horizontal		

Test By : Roger Lu Temperature(°C):23 Humidity(%):65

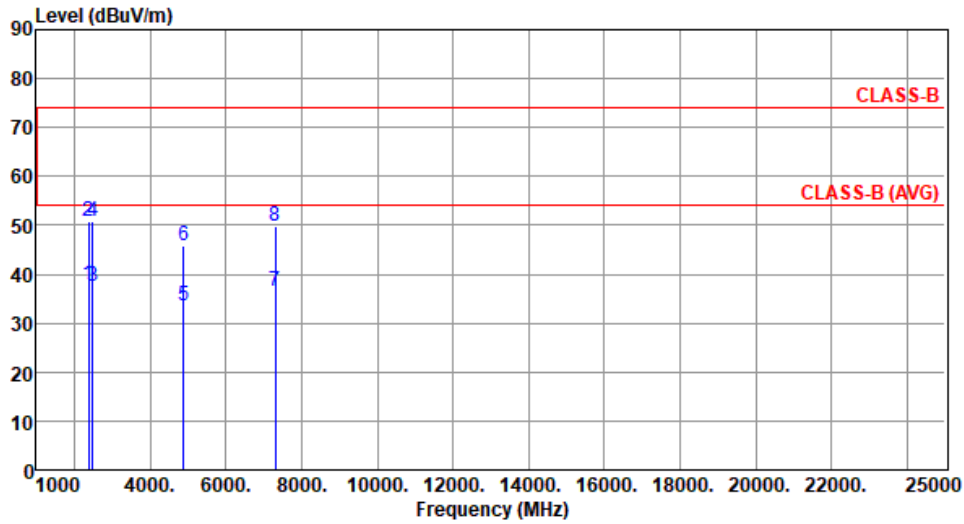

	Freq. MHz	Emission level dBuV/m	Limit dBuV/m	Margin dB	SA reading dBuV	Factor dB/m	Remark	ANT High cm	Turn Table deg
1	2390.00	37.81	54.00	-16.19	40.56	-2.75	Average	196	235
2	2390.00	50.83	74.00	-23.17	53.58	-2.75	Peak	196	235
3	2483.50	37.58	54.00	-16.42	40.28	-2.70	Average	196	235
4	2483.50	50.95	74.00	-23.05	53.65	-2.70	Peak	196	235
5	4880.00	33.70	54.00	-20.30	29.58	4.12	Average	257	132
6	4880.00	45.82	74.00	-28.18	41.70	4.12	Peak	257	132
7	7320.00	36.57	54.00	-17.43	27.29	9.28	Average	100	40
8	7320.00	49.76	74.00	-24.24	40.48	9.28	Peak	100	40

Note 1: Emission Level (dBuV/m) = SA Reading (dBuV) + Factor* (dB/m)

*Factor includes antenna factor , cable loss and amplifier gain

Note 2: Margin (dB) = Emission level (dBuV/m) – Limit (dBuV/m).



Modulation	BT-LE (2Mbps)	Test Freq. (MHz)	2440
Polarization	Vertical		

Test By : Roger Lu Temperature(°C):23 Humidity(%):65

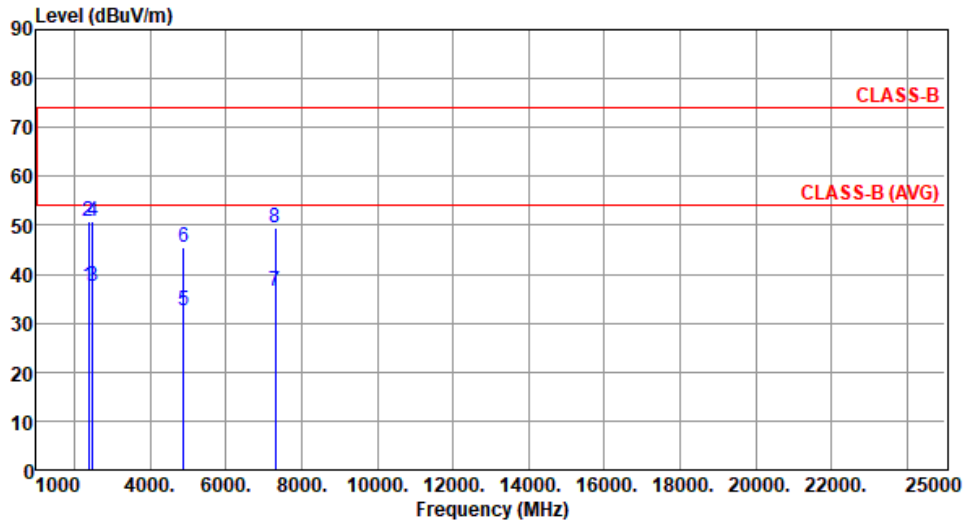

	Freq. MHz	Emission level dBuV/m	Limit dBuV/m	Margin dB	SA reading dBuV	Factor dB/m	Remark	ANT High cm	Turn Table deg
1	2390.00	37.50	54.00	-16.50	40.25	-2.75	Average	326	255
2	2390.00	50.71	74.00	-23.29	53.46	-2.75	Peak	326	255
3	2483.50	37.45	54.00	-16.55	40.15	-2.70	Average	326	255
4	2483.50	50.73	74.00	-23.27	53.43	-2.70	Peak	326	255
5	4880.00	32.54	54.00	-21.46	28.42	4.12	Average	100	179
6	4880.00	45.37	74.00	-28.63	41.25	4.12	Peak	100	179
7	7320.00	36.43	54.00	-17.57	27.15	9.28	Average	100	30
8	7320.00	49.57	74.00	-24.43	40.29	9.28	Peak	100	30

Note 1: Emission Level (dBuV/m) = SA Reading (dBuV) + Factor* (dB/m)

*Factor includes antenna factor , cable loss and amplifier gain

Note 2: Margin (dB) = Emission level (dBuV/m) – Limit (dBuV/m).



Modulation	BT-LE (2Mbps)	Test Freq. (MHz)	2480
Polarization	Horizontal		

Test By : Roger Lu Temperature(°C):23 Humidity(%):65

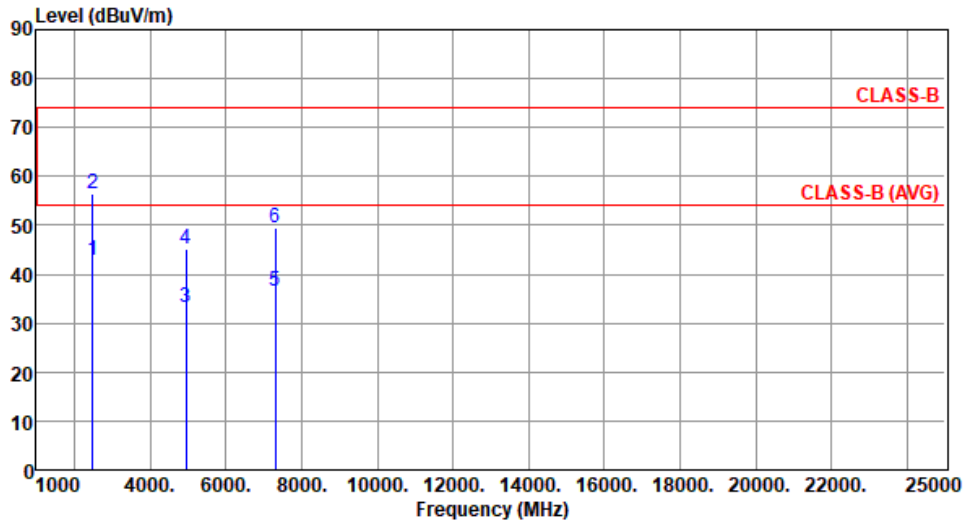

	Freq. MHz	Emission level dBuV/m	Limit dBuV/m	Margin dB	SA reading dBuV	Factor dB/m	Remark	ANT High cm	Turn Table deg
1	2483.50	42.71	54.00	-11.29	45.41	-2.70	Average	236	237
2	2483.50	56.44	74.00	-17.56	59.14	-2.70	Peak	236	237
3	4960.00	33.15	54.00	-20.85	29.12	4.03	Average	261	135
4	4960.00	45.31	74.00	-28.69	41.28	4.03	Peak	261	135
5	7320.00	36.53	54.00	-17.47	27.25	9.28	Average	100	30
6	7320.00	49.57	74.00	-24.43	40.29	9.28	Peak	100	30

Note 1: Emission Level (dBuV/m) = SA Reading (dBuV) + Factor* (dB/m)

*Factor includes antenna factor , cable loss and amplifier gain

Note 2: Margin (dB) = Emission level (dBuV/m) – Limit (dBuV/m).



Modulation	BT-LE (2Mbps)	Test Freq. (MHz)	2480
Polarization	Vertical		

Test By : Roger Lu Temperature(°C):23 Humidity(%):65

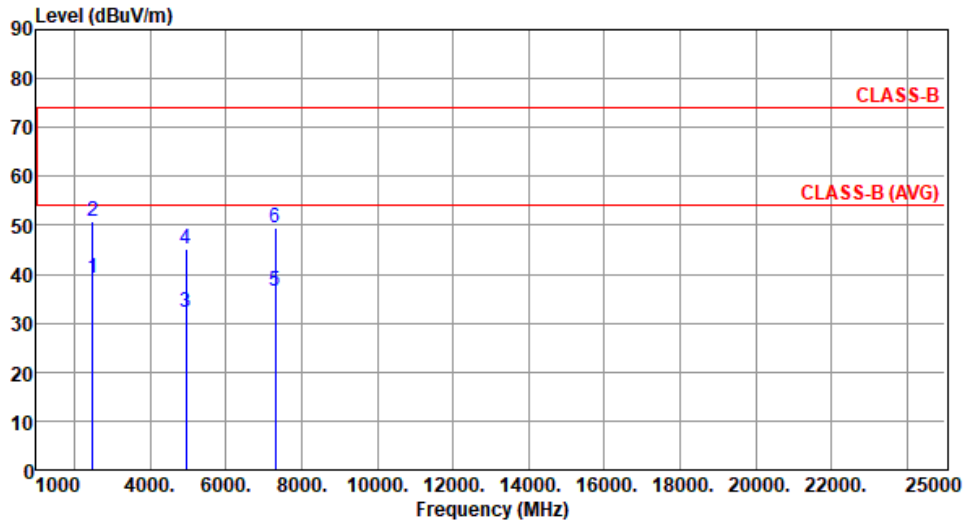

	Freq. MHz	Emission level dBuV/m	Limit dBuV/m	Margin dB	SA reading dBuV	Factor dB/m	Remark	ANT High cm	Turn Table deg
1	2483.50	39.26	54.00	-14.74	41.96	-2.70	Average	330	260
2	2483.50	50.97	74.00	-23.03	53.67	-2.70	Peak	330	260
3	4960.00	32.25	54.00	-21.75	28.22	4.03	Average	100	176
4	4960.00	45.06	74.00	-28.94	41.03	4.03	Peak	100	176
5	7320.00	36.40	54.00	-17.60	27.12	9.28	Average	100	25
6	7320.00	49.41	74.00	-24.59	40.13	9.28	Peak	100	25

Note 1: Emission Level (dBuV/m) = SA Reading (dBuV) + Factor* (dB/m)

*Factor includes antenna factor , cable loss and amplifier gain

Note 2: Margin (dB) = Emission level (dBuV/m) – Limit (dBuV/m).

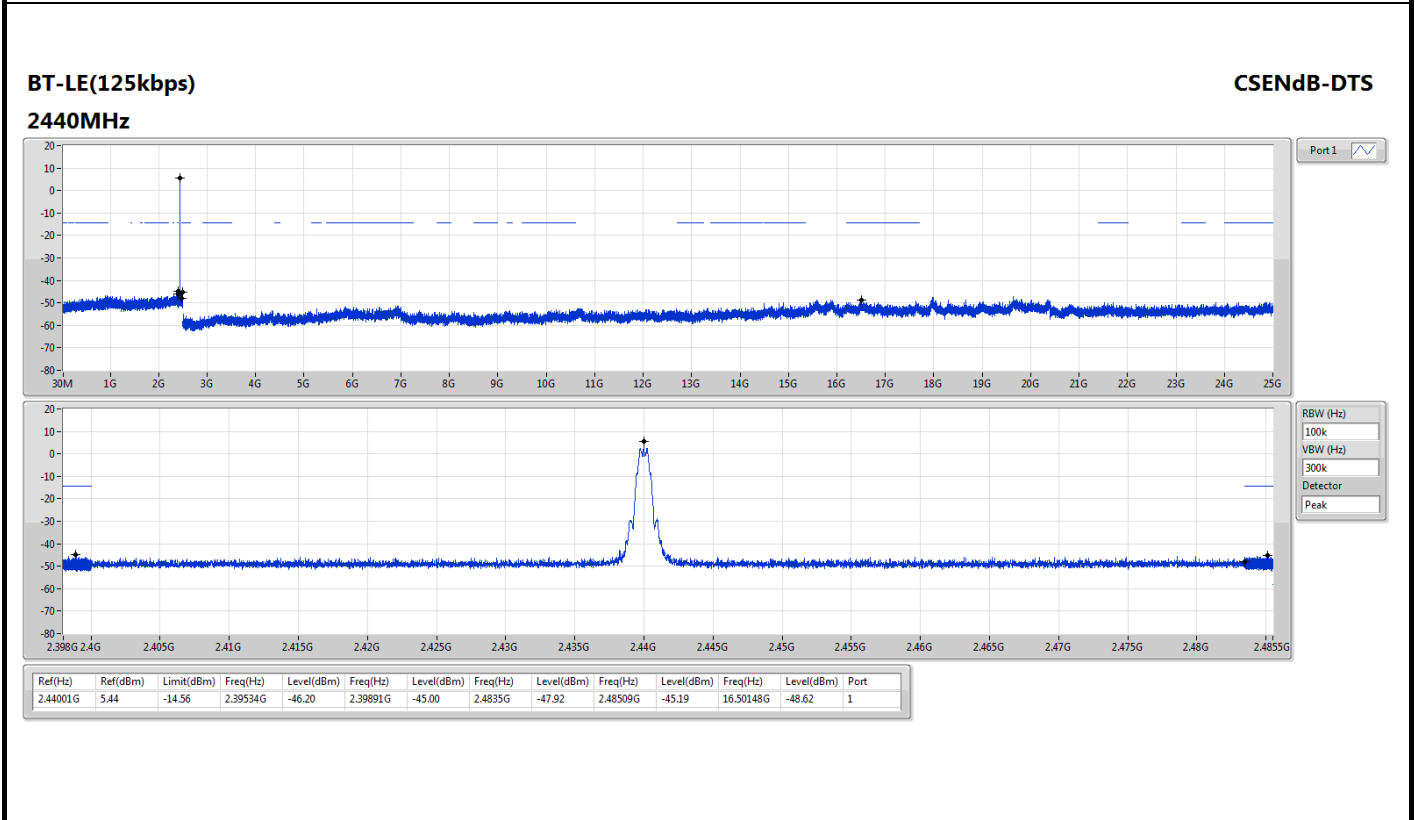
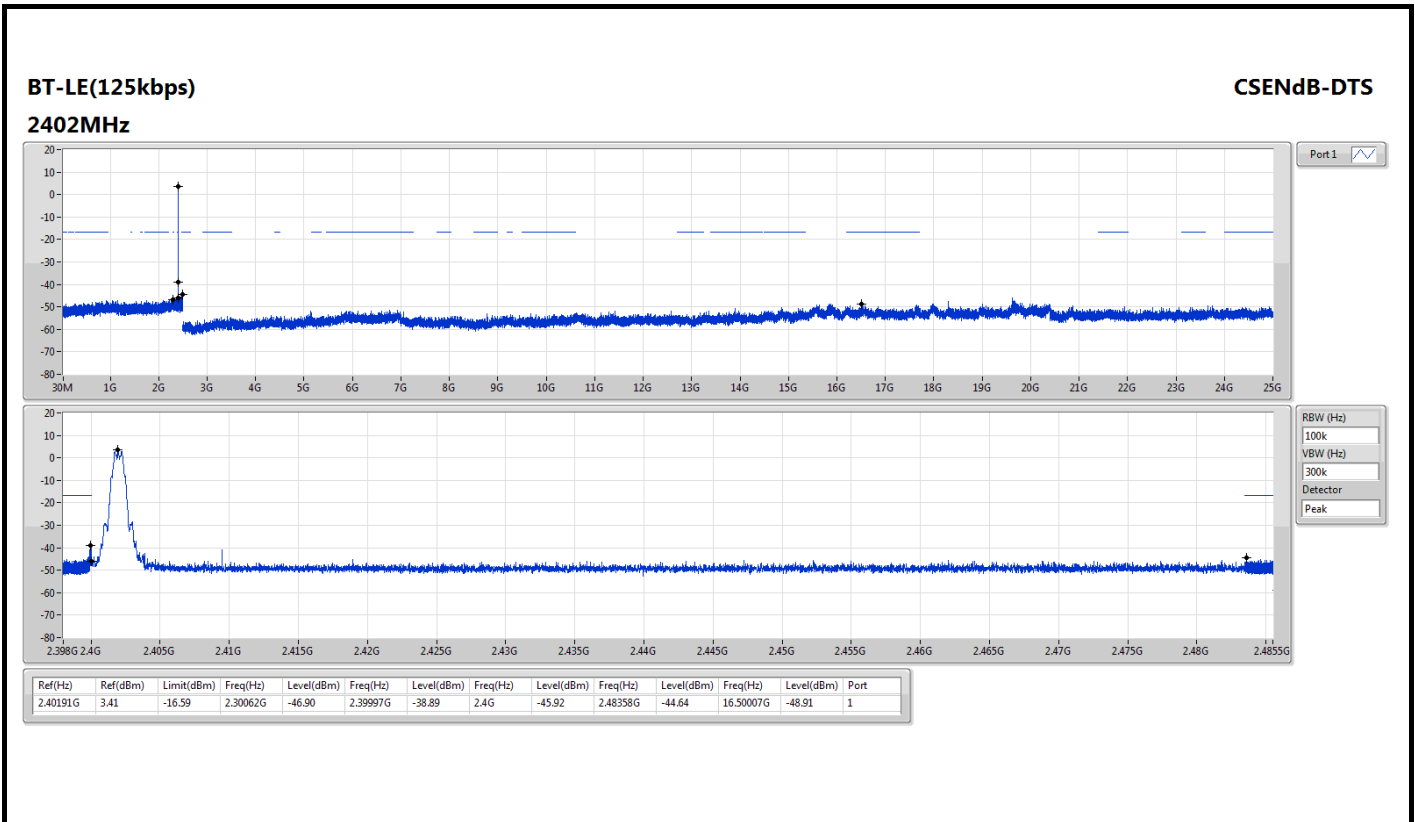



BT-LE(125kbps)

CSEndB-DTS

2480MHz

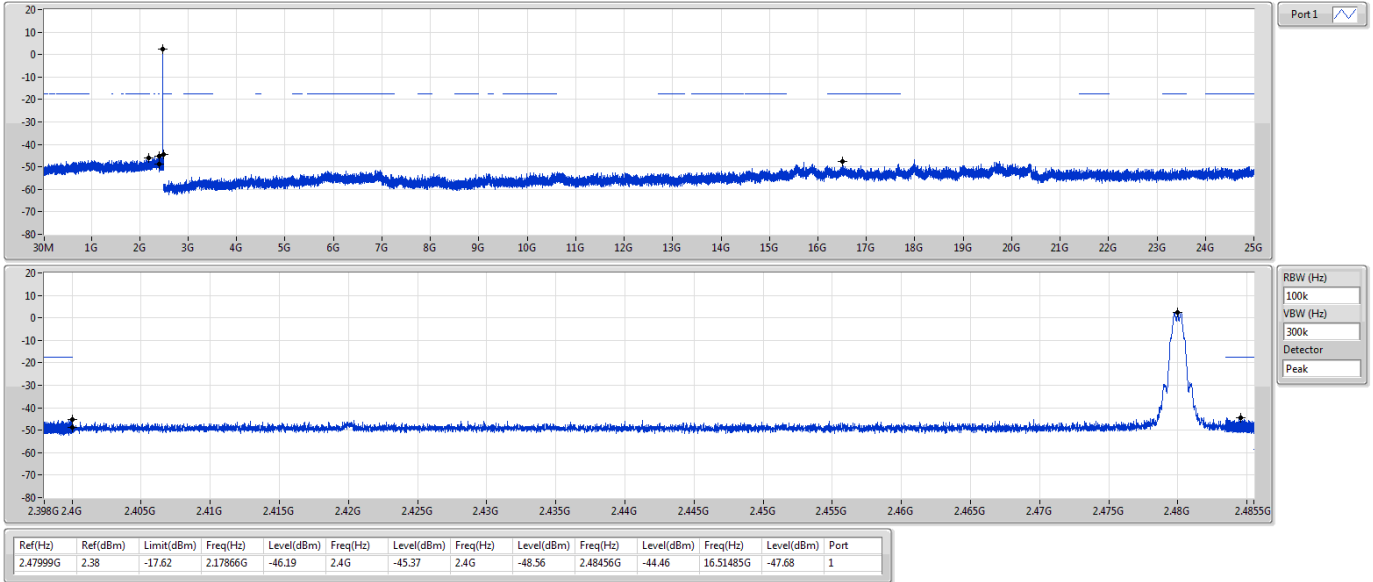

BT-LE(500kbps)

CSEndB-DTS

2402MHz

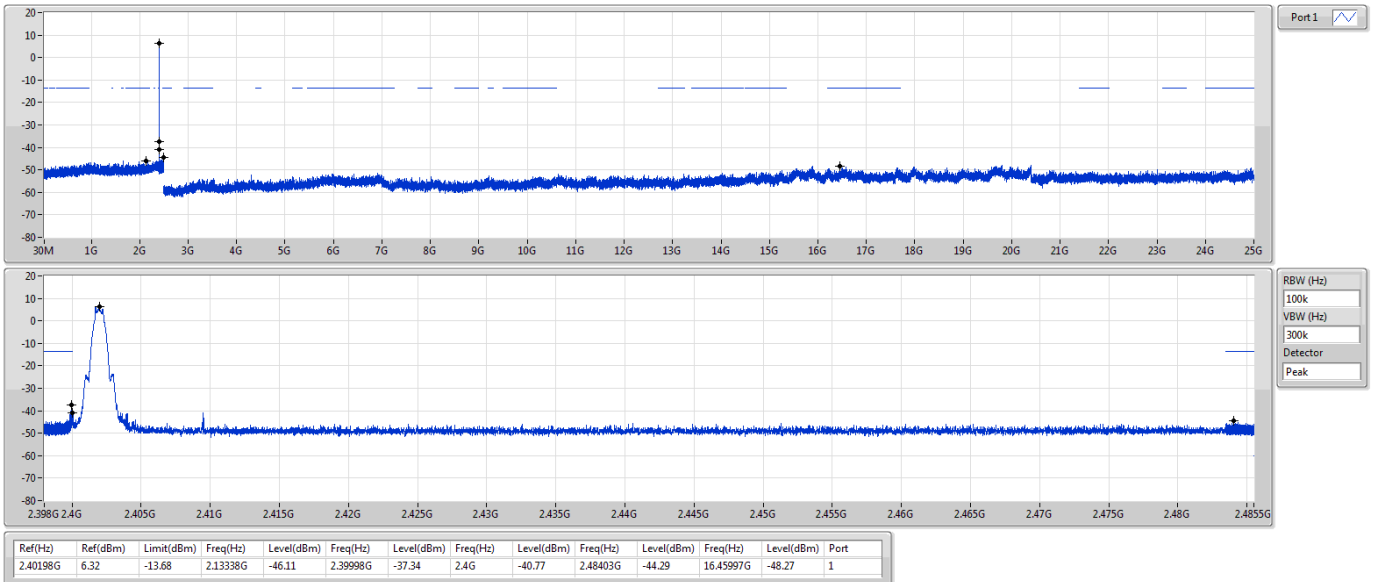

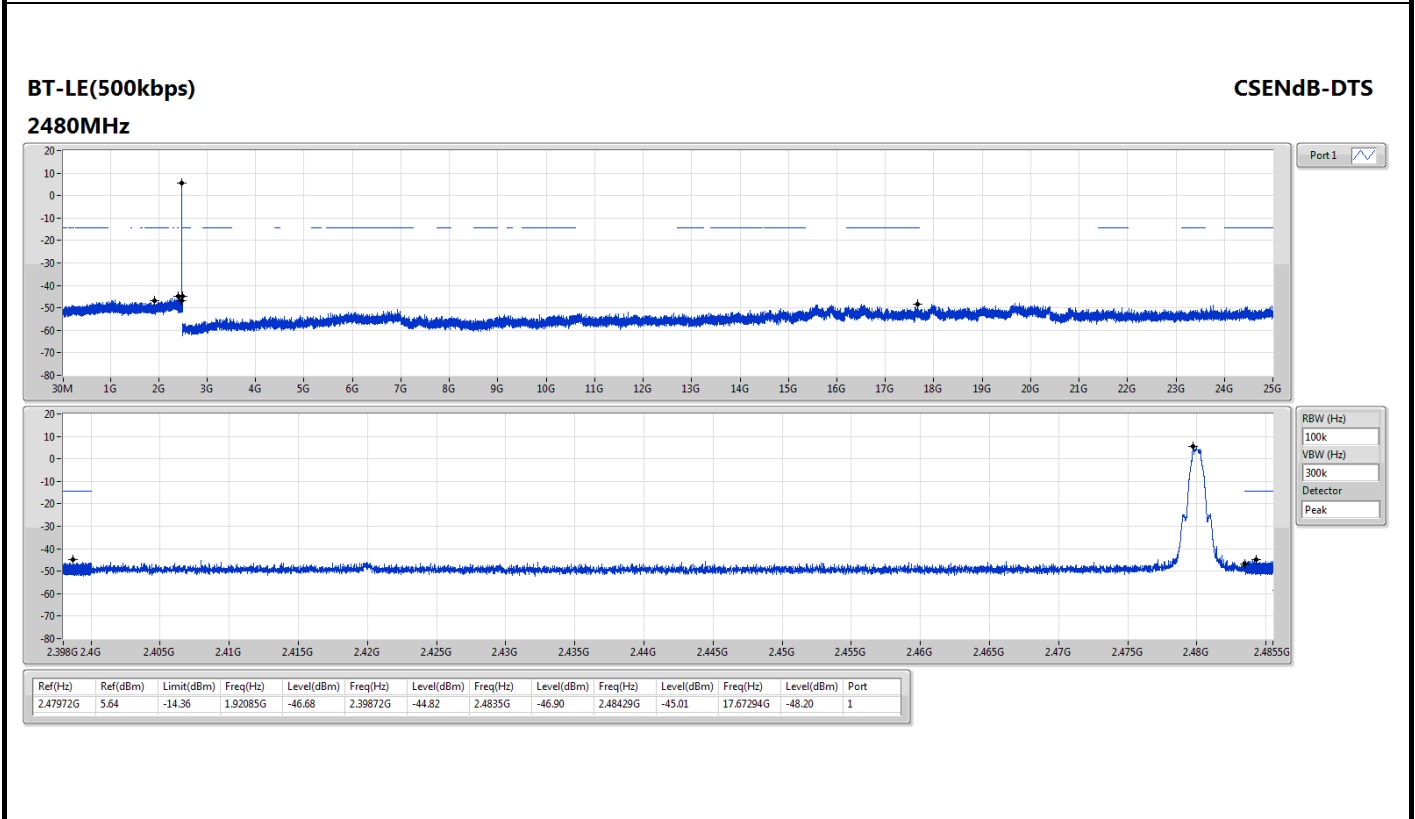
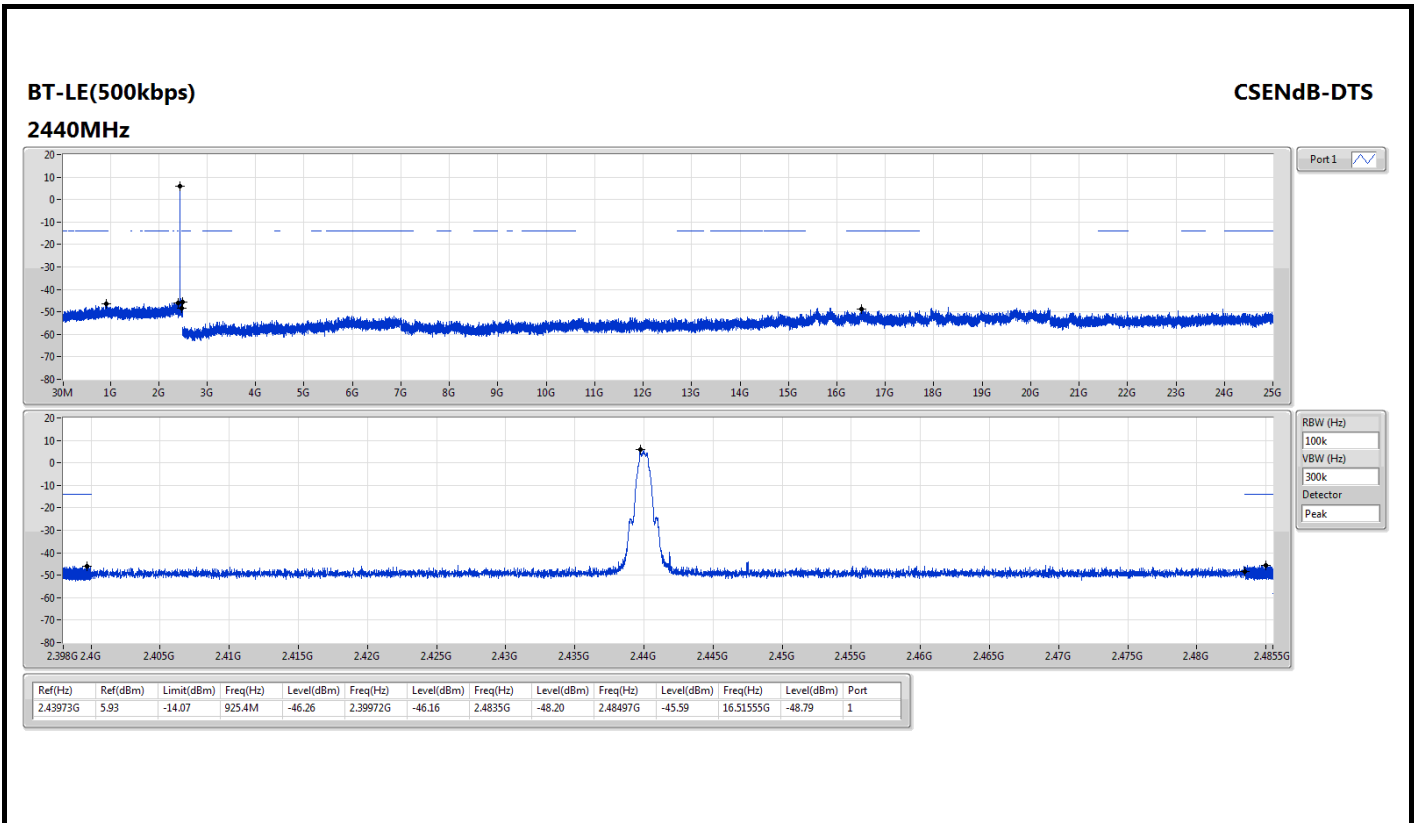

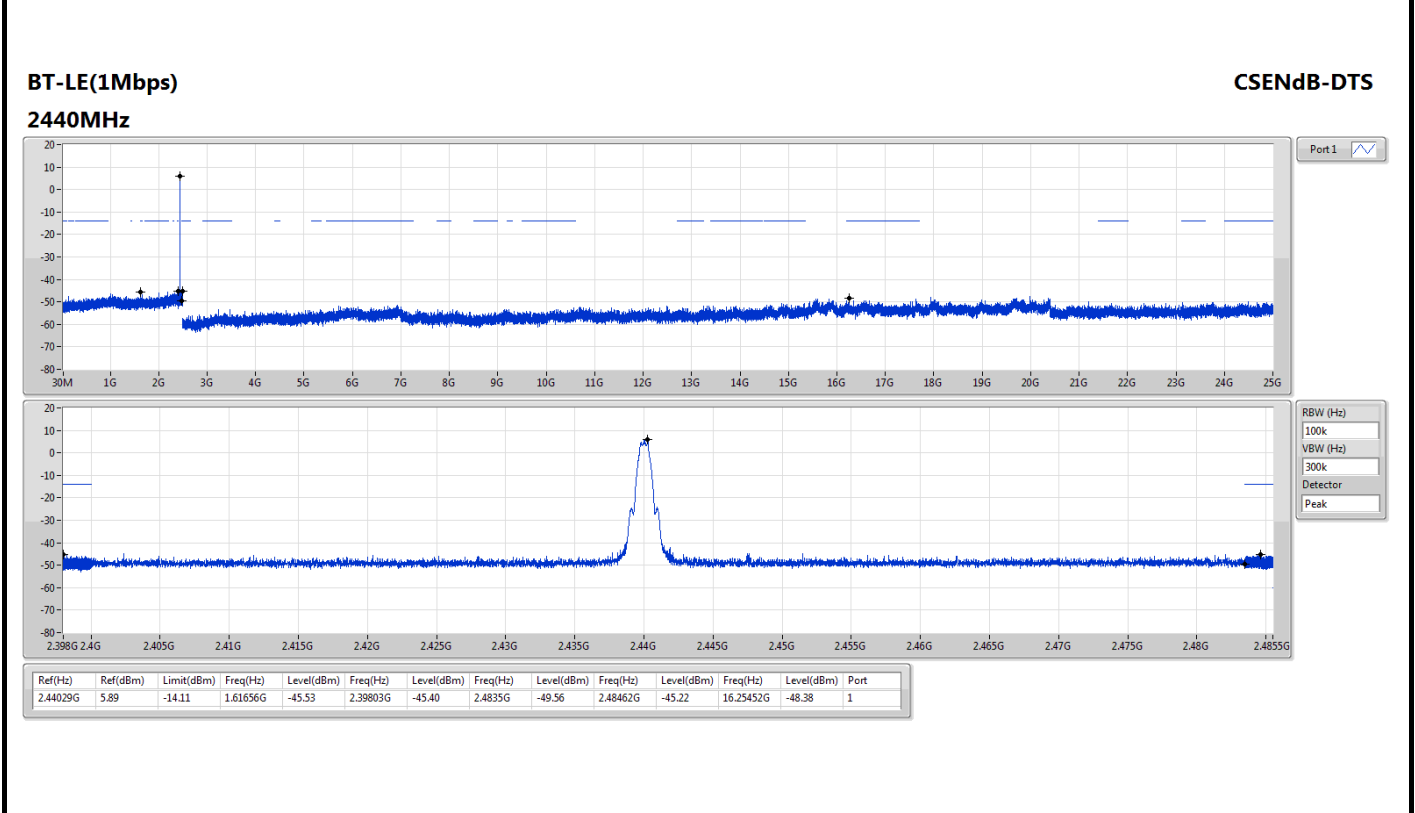
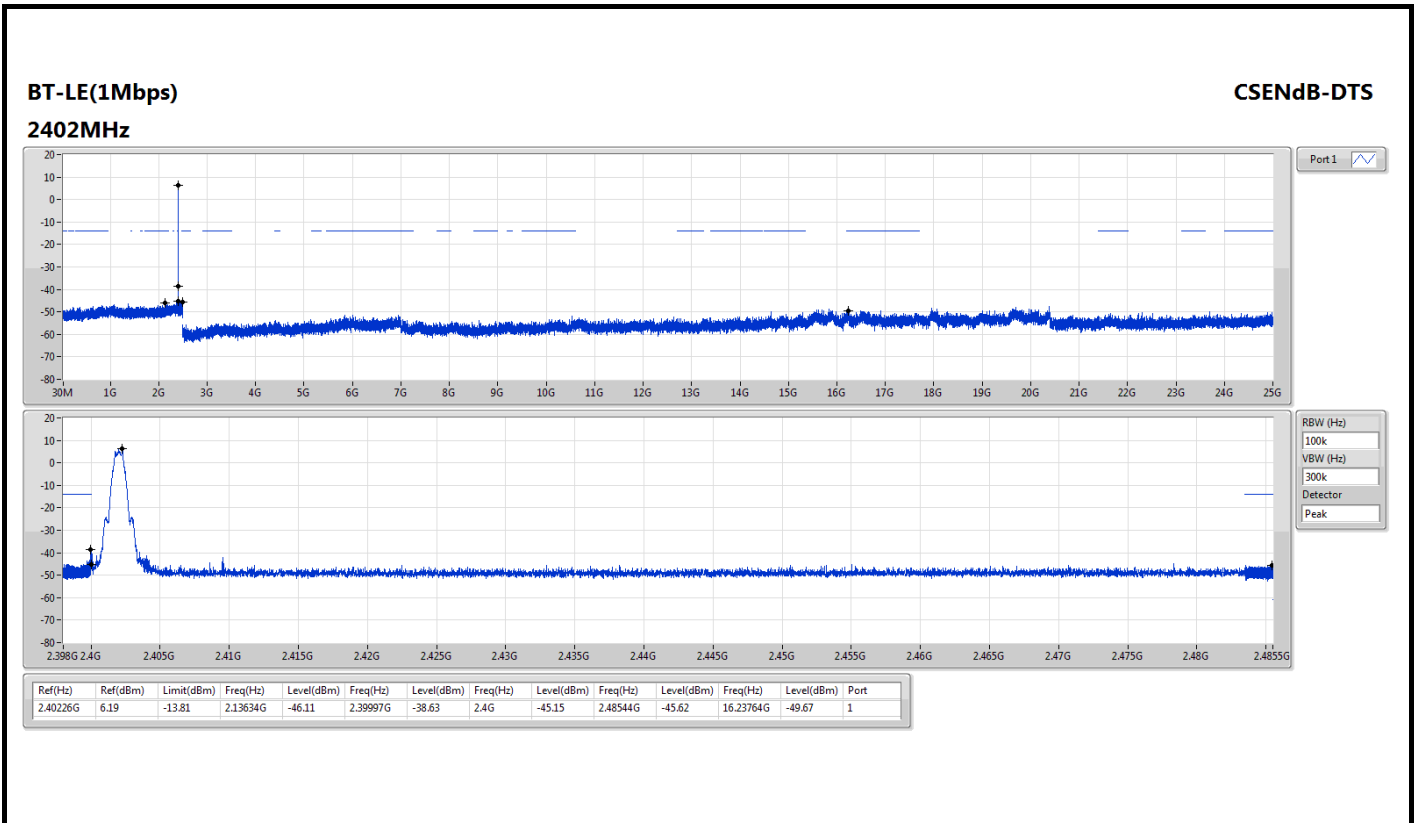

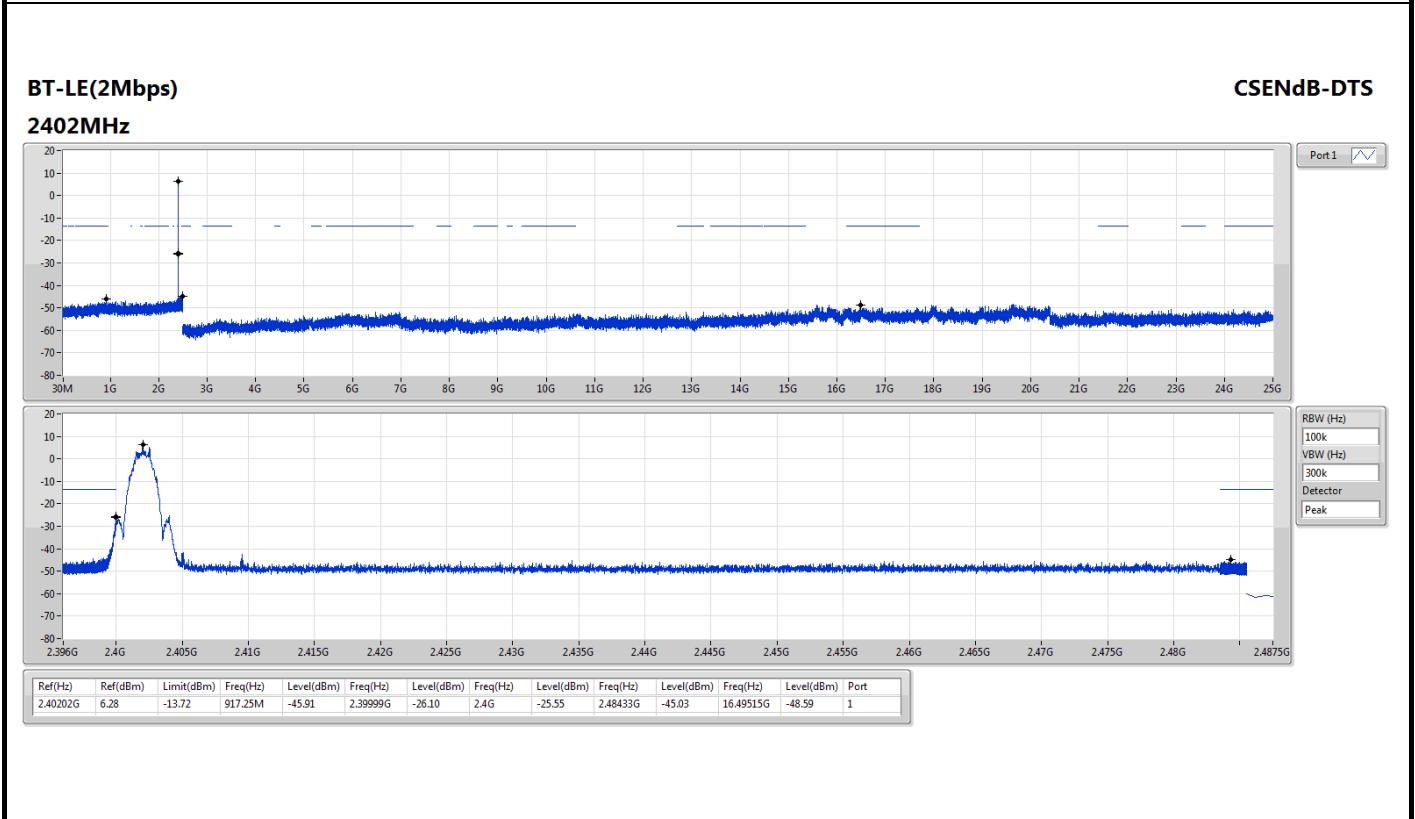
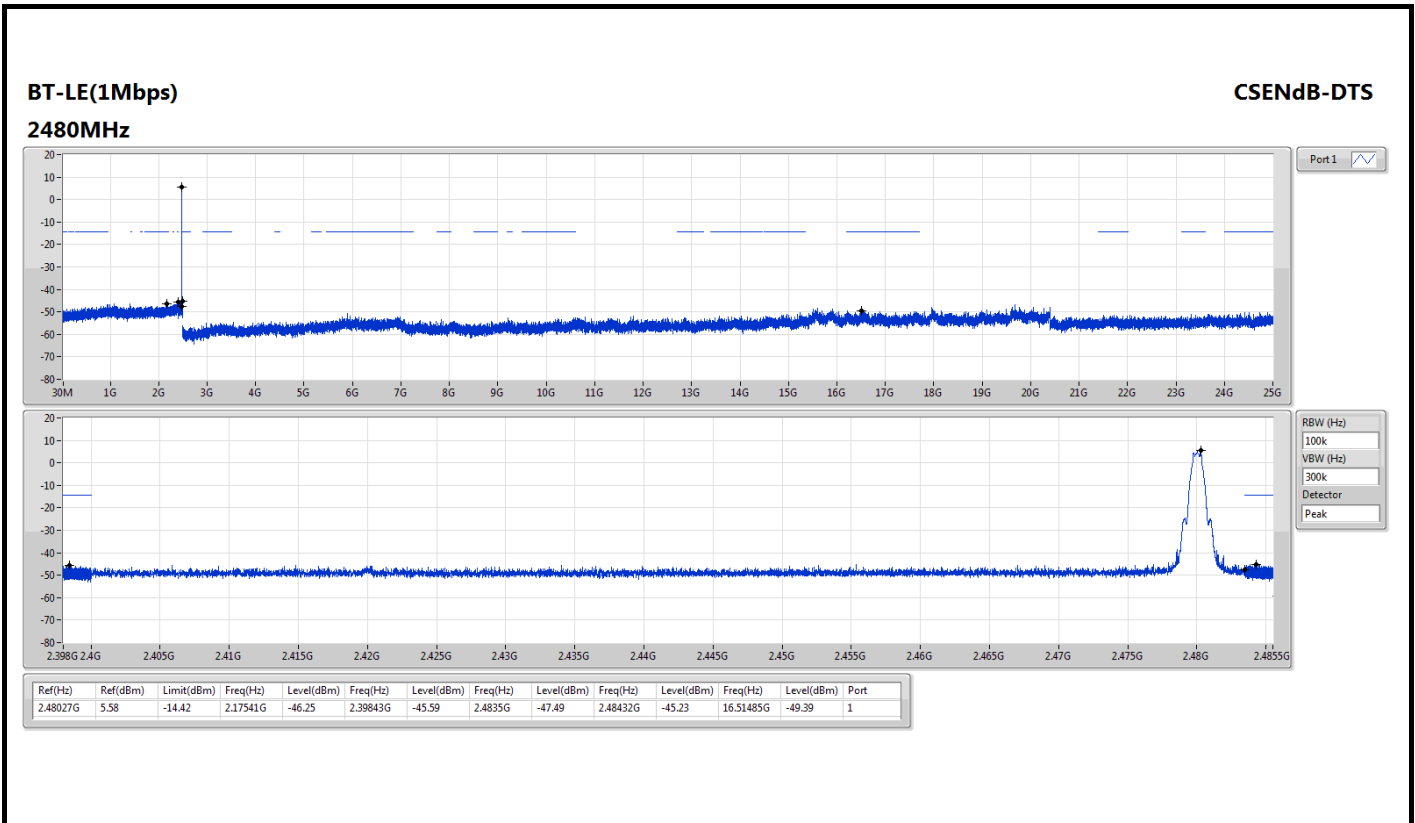

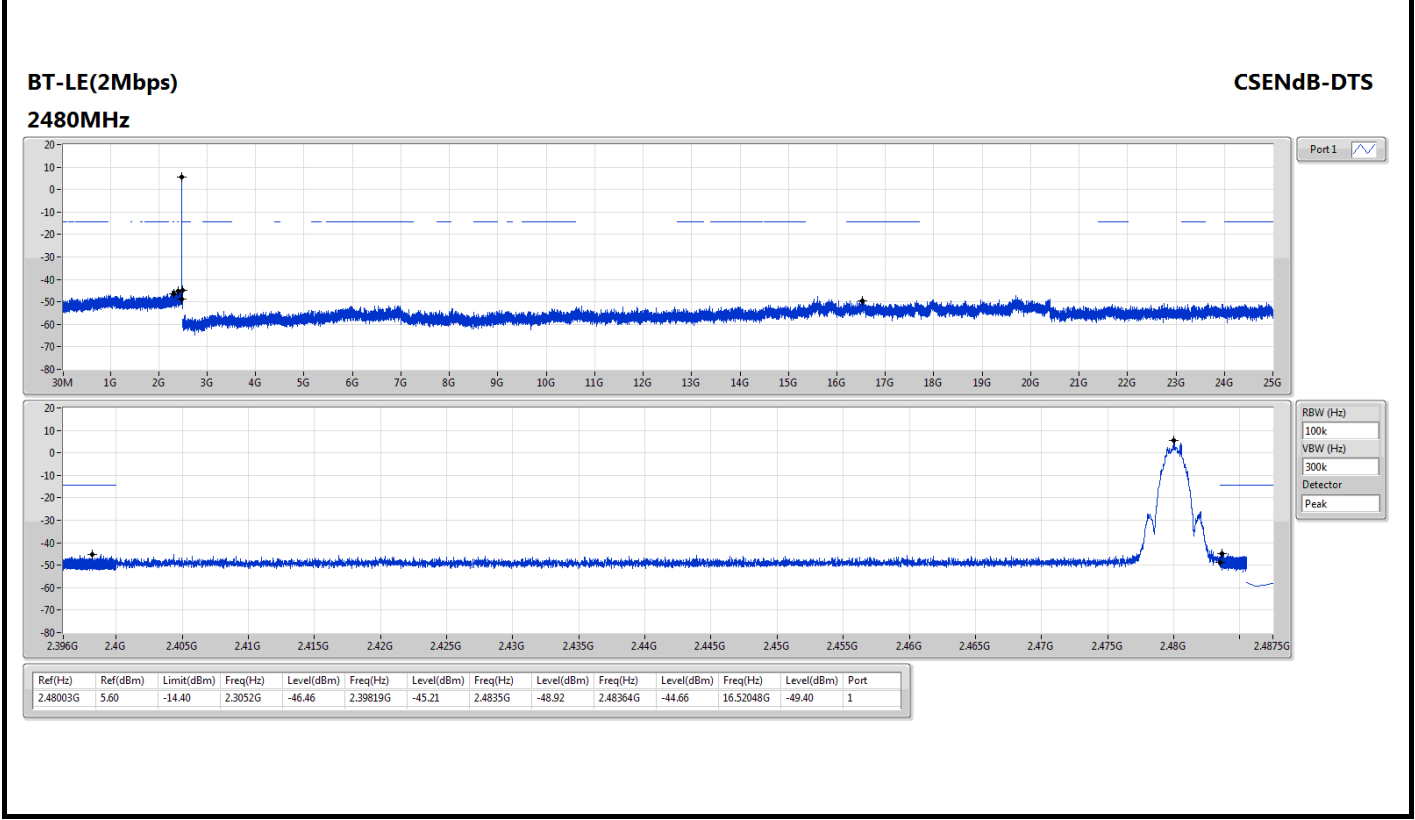
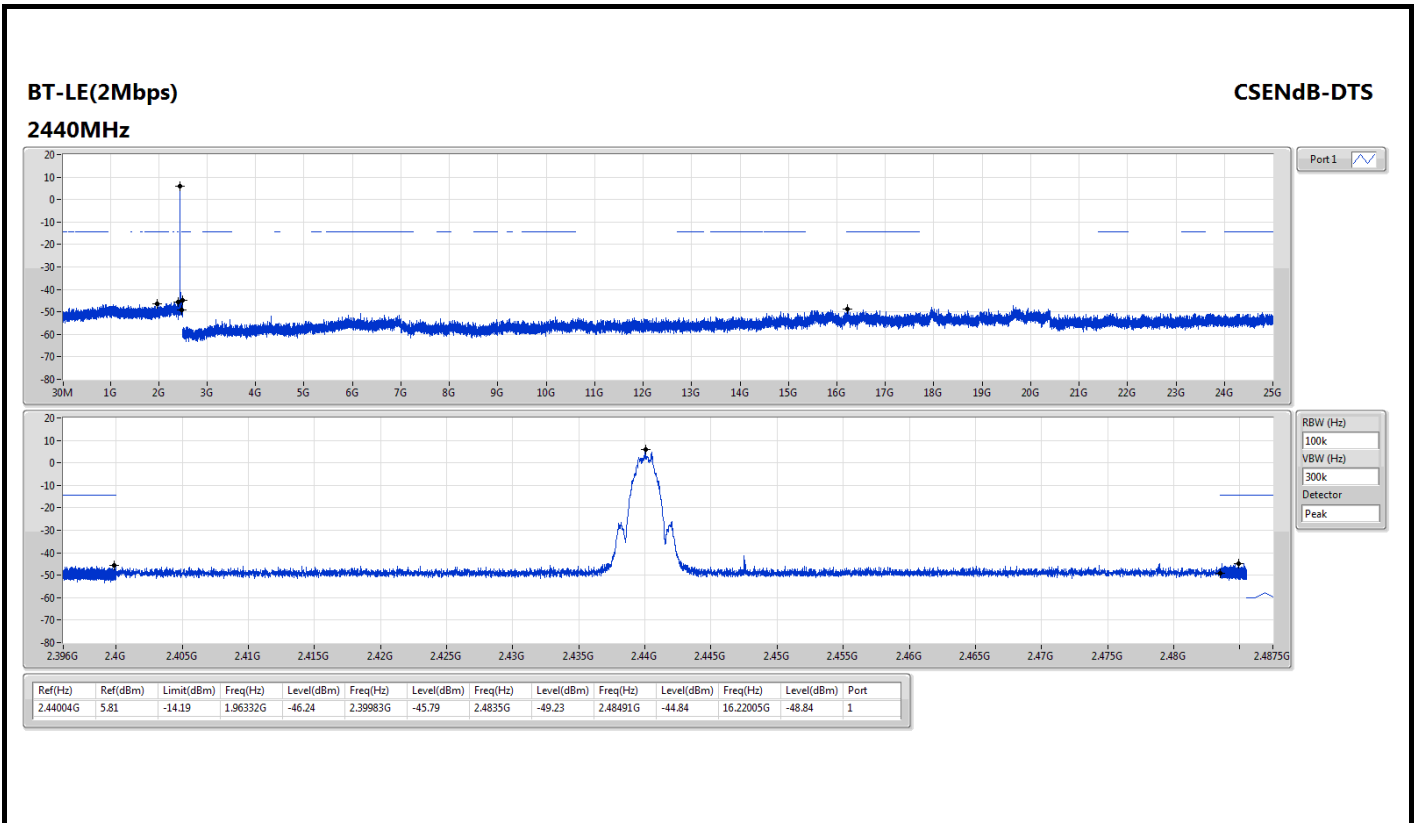



Modulation	BT-LE(1Mbps)	Test Freq. (MHz)	2402
Power Phase	Line		

Test by : Joe Liao Temperature: 19°C Humidity: 62%

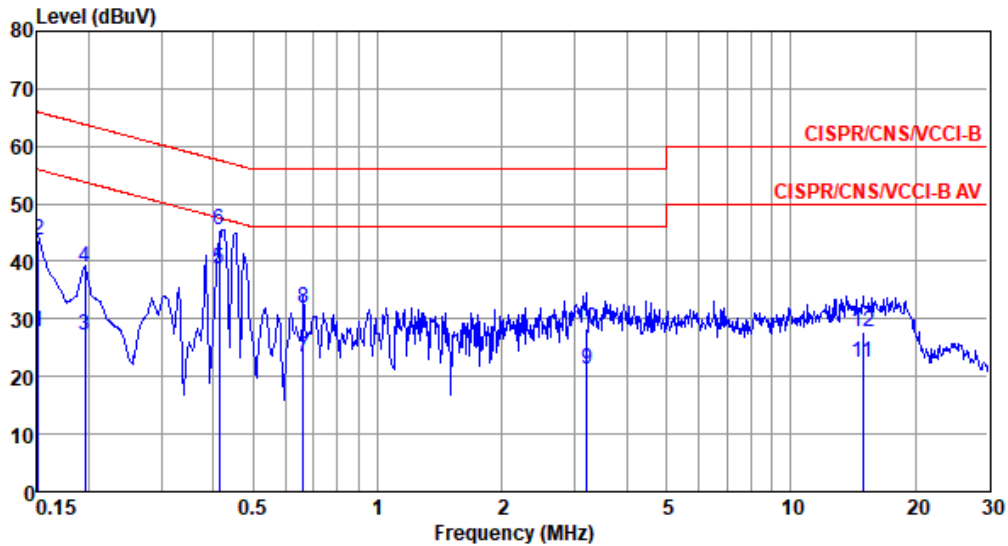

	Freq MHz	Level dBuV	Limit Line dBuV	Over Limit dB	Read Level dBuV	Factor dB	Cable loss dB	Aux dB	Remark
1	0.151	27.63	55.96	-28.33	17.87	9.68	0.08	0.00	Average
2	0.151	43.69	65.96	-22.27	33.93	9.68	0.08	0.00	QP
3	0.195	27.05	53.80	-26.75	17.29	9.68	0.08	0.00	Average
4	0.195	38.96	63.80	-24.84	29.20	9.68	0.08	0.00	QP
5*	0.413	38.56	47.59	-9.03	28.81	9.67	0.08	0.00	Average
6	0.413	45.37	57.59	-12.22	35.62	9.67	0.08	0.00	QP
7	0.661	23.36	46.00	-22.64	13.56	9.68	0.12	0.00	Average
8	0.661	31.77	56.00	-24.23	21.97	9.68	0.12	0.00	QP
9	3.207	21.18	46.00	-24.82	11.27	9.70	0.21	0.00	Average
10	3.207	28.46	56.00	-27.54	18.55	9.70	0.21	0.00	QP
11	14.907	22.51	50.00	-27.49	12.22	9.73	0.56	0.00	Average
12	14.907	27.89	60.00	-32.11	17.60	9.73	0.56	0.00	QP

Note 1: Level (dBuV) = Read Level (dBuV) + LISN Factor (dB) + Cable Loss (dB) + Aux (dB).
 Note 2: Over Limit (dB) = Level (dBuV) – Limit Line (dBuV).



Modulation	BT-LE(1Mbps)	Test Freq. (MHz)	2402
Power Phase	Neutral		

Test by : Joe Liao Temperature: 19°C Humidity: 62%

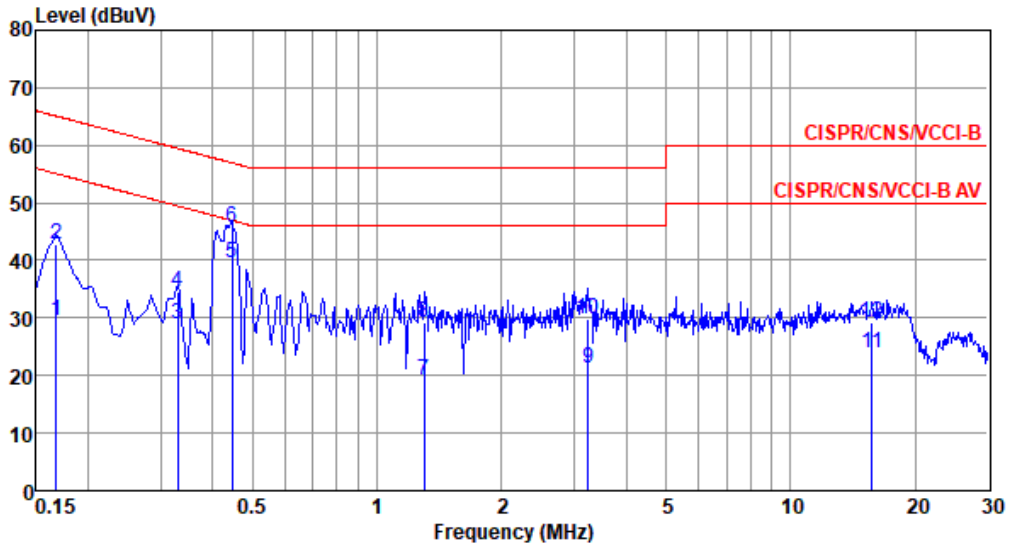

	Freq MHz	Level dBuV	Limit Line dBuV	Over Limit dB	Read Level dBuV	Factor dB	Cable loss dB	Aux dB	Remark
1	0.168	29.55	55.08	-25.53	19.86	9.61	0.08	0.00	Average
2	0.168	42.89	65.08	-22.19	33.20	9.61	0.08	0.00	QP
3	0.330	28.97	49.44	-20.47	19.28	9.61	0.08	0.00	Average
4	0.330	34.66	59.44	-24.78	24.97	9.61	0.08	0.00	QP
5*	0.447	39.48	46.93	-7.45	29.78	9.61	0.09	0.00	Average
6	0.447	45.69	56.93	-11.24	35.99	9.61	0.09	0.00	QP
7	1.303	19.21	46.00	-26.79	9.42	9.61	0.18	0.00	Average
8	1.303	29.12	56.00	-26.88	19.33	9.61	0.18	0.00	QP
9	3.241	21.31	46.00	-24.69	11.47	9.63	0.21	0.00	Average
10	3.241	29.87	56.00	-26.13	20.03	9.63	0.21	0.00	QP
11	15.718	23.89	50.00	-26.11	13.57	9.75	0.57	0.00	Average
12	15.718	29.10	60.00	-30.90	18.78	9.75	0.57	0.00	QP

Note 1: Level (dBuV) = Read Level (dBuV) + LISN Factor (dB) + Cable Loss (dB) + Aux (dB).
 2: Over Limit (dB) = Level (dBuV) – Limit Line (dBuV).