

Control Unit (used 4G/3G/GSM Communication)
JRN-360T
User Manual

Document number: LE-20Y501-E
Ver.1.01

Date: Mar. 31, 2022

JRC Mobility Inc.
Locator Products Group
Product Development Department

History

Date	Number	The contents of change
Mar. 18, 2022	1.00	
Mar. 30, 2022	1.01	7.2 Precautions for use 5. Change the description 10. Delete item 7.3 Notes on Equipment installation 1. Change the description 2,4 Delete item 7.5 Storage precautions 1. Change the description 7.7 Disposal Delete item 8 Compliance with FCC and IC Rules and Regulations Add item RF exposure compliance

Table of contents

1	Introduction	4
2	Composition	4
3	Function	5
4	Product Specification	6
5	Outline	10
6	Option	11
7	Handling precautions	14
8	Compliance with FCC and IC Rules and Regulations	18

1 Introduction

This specification is an instruction manual for a 4G compatible communication terminal (JRN-360T).

JRN-360T is a small terminal for Construction equipment to have the GNSS measurement function and the 4G/3G/GSM communication function, and to use it for management and positional information track etc. of the Construction equipment. (JRN-360T is a device dedicated to specific customers and will not be sold to the general public.)

1.1 Overview

communication unit equipped with GSM / W-CDMA / FD-LTE packet data communication function and GNSS reception function.

As a communications protocol TCP / IP / PPP are mounted.

■Frequency bands

GSM : GSM850, GSM900, GSM1800, GSM1900

W-CDMA : B1, B2, B4, B5, B8, B19

FD-LTE : B1, B2, B3, B4, B5, B7, B8, B12, B18, B19, B20, B28

2 Composition

NO.	品名	型名	数量
1	Communication terminal	JRN-360T	1
1-1	2G/3G/4G Communications Module	Cinterion PLS63-W (THALES product)	1
1-2	Communication antenna	CAU-7360TA *Built-in antenna	1
1-3	SIM Interface	e-SIM	1
2	GNSS antenna	7ABLE0008	1

(Note #1) ECU connection and battery cable are not included.

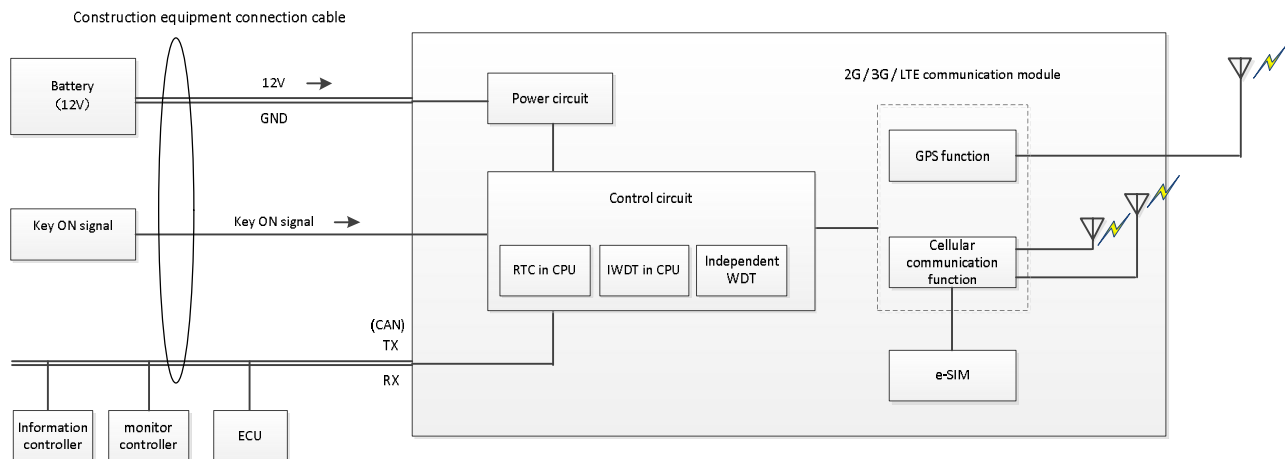

(Note#1) Please prepare IF cable by the visitor side.

(Note#2) A connection I/F cable requires a 5A fuse because of over-current protection.

Please insert the fuse in a battery.

(Note#3) Please do not take a power supply from DC cigar socket.

It becomes the cause that operation is poor, according to bad connection.

3 Function

3.1 Communication function with mail server.

Receives the request by SMS and sends the result to the TFTP server.

3.2 Firmware update Over The Air

Receipt of the rewrite request command, the update file is downloaded from the server and firmware of the communication terminal is updated.

3.3 GNSS information acquisition function

After starting the device, the GNSS module is started immediately.

When the GNSS information can be positioned normally, the date and time of the GNSS information is reflected on the RTC of the apparatus.

3.4 Sleep control function

To reduce power consumption, the key OFF (engine OFF) is the starting point, the standby state is entered, and after the set number of sleep transition days has elapsed, the sleep state is entered.

Communication and GNSS positioning do not work in sleep mode. The only way to return is to turn key ON(engine ON).

3.5 Communication function

2G (GSM) / 3G (W-CDMA) / 4G (FD-LTE) packet communication is possible. (Voice communication is not supported)

3.6 Communication terminal control

Controlled by CAN communication from the ECU.

3.7 Monitor function

The GNSS antenna connection status can be monitored by CAN communication.

3.8 LED indication

LED indication is controlled the following conditions

- When the key ON and coverage area, it blinks at a slow cycle (blinking cycle: 2 seconds).
- When the key ON and no signal, it blinks with a fast cycle (blinking cycle: 0.5 seconds).
- When the key OFF, LED light turns off (standby or sleep mode).

4 Product Specification

4.1 Common Specifications

NO.	Items	Specification performance
1	Dimension	130(W) × 60(D) × 30(H)
2	Weight	210g or less
3	Power supply voltage	8~16V (typ:12V)
4	Communication module	PLS63-W (THALES product)
5	e-SIM	Embedded Subscriber Identity Module
6	Current	Transmission (MAX) : 1.7A or less@12V Standby mode : 10mA or less@12V Sleep mode : 2mA or less@12V
7	External I/F	Control I/F connector
8	Circumference environment	Operation : -30 ~ +70°C Preservation : -40 ~ +85°C Humidity of operation : 0 ~ 95%RH
9	Case material	PBT resin (GF reinforced)

4.2 CAN I/F

NO.	Items	Specification performance
1	Data transmission	SAE J1939
2	Speed	250 / 500 kbps Depends on terminal settings.

4.3 4G/3G/GSM module Specification

NO.	Items	Specification performance
1	Model	Cinterion PLS63-W (THALES product)
2	Frequency bands	GSM/GPRS/EDGE: 850MHz 900MHz 1800MHz 1900MHz UMTS/HSPA+: Bd.1 (2100MHz) Bd.2 (1900MHz) Bd.3 (1800MHz)

		<p>Bd.4 (2100MHz) Bd.5 (850MHz) Bd.6 (850MHz) Bd.8 (900MHz) Bd.19 (850MHz)</p> <p>LTE: Bd.1 (2100MHz) Bd.2 (1900MHz) Bd.3 (1800MHz) Bd.4 (2100MHz) Bd.5 (850MHz) Bd.7 (2600MHz) Bd.8 (900MHz) Bd.12 (700MHz) Bd.13 (700MHz) Bd.18 (850MHz) Bd.19 (850MHz) Bd.20 (800MHz) Bd.26 (850MHz) Bd.28 (700MHz) Bd.66(2100MHz) Bd.38 (2600MHz) Bd.40 (2300MHz) Bd.41 (2500MHz)</p>
3	GSM class	Small MS
4	Output power (according to release 99)	<p>Class 4 (+33dBm ± 2dB) for GSM850 Class 4 (+33dBm ± 2dB) for GSM900 Class 1 (+30dBm ± 2dB) for GSM1800 Class 1 (+30dBm ± 2dB) for GSM1900 Class E2 (+27dBm ± 3dB) for GSM 850 8-PSK Class E2 (+27dBm ± 3dB) for GSM 900 8-PSK Class E2 (+26dBm +3 /-4dB) for GSM 1800 8-PSK Class E2 (+26dBm +3 /-4dB) for GSM 1900 8-PSK</p>
5	Output power (according to Release 99)	<p>Class 3 (+24dBm +1/-3dB) for UMTS 850, WCDMA FDD BdXIX Class 3 (+24dBm +1/-3dB) for UMTS 850, WCDMA FDD BdVI Class 3 (+24dBm +1/-3dB) for UMTS 850, WCDMA FDD BdV Class 3 (+24dBm +1/-3dB) for UMTS 900, WCDMA FDD BdVIII Class 3 (+24dBm +1/-3dB) for UMTS 1700, WCDMA FDD BdIII Class 3 (+24dBm +1/-3dB) for UMTS 1900, WCDMA FDD BdII Class 3 (+24dBm +1/-3dB) for UMTS 2100, WCDMA FDD BdIV Class 3 (+24dBm +1/-3dB) for UMTS 2100, WCDMA FDD BdI</p>
6	Output power (according to Release 8)	<p>Class 3 (+23dBm ± 2dB) for LTE 600, LTE FDD Bd71 Class 3 (+23dBm ± 2dB) for LTE 700, LTE FDD Bd12 <MFBI Bd17> Class 3 (+23dBm ± 2dB) for LTE 700, LTE FDD Bd13 Class 3 (+23dBm ± 2dB) for LTE 700, LTE FDD Bd14 Class 3 (+23dBm+2/-2.5dB) for LTE 700, LTE FDD Bd28 Class 3 (+23dBm ± 2dB) for LTE 850, LTE FDD Bd26 Class 3 (+23dBm ± 2dB) for LTE 850, LTE FDD Bd18 Class 3 (+23dBm ± 2dB) for LTE 850, LTE FDD Bd19</p>

		<p>Class 3 (+23dBm ± 2dB) for LTE 800, LTE FDD Bd20</p> <p>Class 3 (+23dBm ± 2dB) for LTE 850, LTE FDD Bd5</p> <p>Class 3 (+23dBm ± 2dB) for LTE 900, LTE FDD Bd8</p> <p>Class 3 (+23dBm ± 2dB) for LTE 1800, LTE FDD Bd3</p> <p>Class 3 (+23dBm ± 2dB) for LTE 1900, LTE FDD Bd2</p> <p>Class 3 (+23dBm ± 2dB) for LTE 1900, LTE FDD Bd25</p> <p>Class 3 (+23dBm ± 2dB) for LTE 2100, LTE FDD Bd1</p> <p>Class 3 (+23dBm ± 2dB) for LTE 2100, LTE FDD Bd4</p> <p>Class 3 (+23dBm ± 2dB) for LTE 2100, LTE FDD Bd66</p> <p>Class 3 (+23dBm ± 2dB) for LTE 2600, LTE FDD Bd7</p> <p>Class 3 (+23dBm ± 2dB) for LTE 2300, LTE TDD Bd40</p> <p>Class 3 (+23dBm ± 2dB) for LTE 2500, LTE TDD Bd41</p> <p>Class 3 (+23dBm ± 2dB) for LTE 2600, LTE TDD Bd38</p>
7	Power supply	<p>Normal operation:</p> <p>3.0V < VBATT+ < 4.5V</p> <p>Typ value is 3.8V</p>
8	Operating temperature	<p>Normal operation: -30° C to +85° C</p> <p>Extended operation: -40° C to -30° C, +85° C to +95° C;</p>
9	Physical	<p>Dimensions: 33mm x 29mm x 2.5mm</p> <p>Weight: approx. 4.8g</p>
10	RoHS	All hardware components fully compliant with EU RoHS Directive
11	LTE features	<p>3GPP Release 10</p> <p>UE CAT 1 for PLS63 (DL 10Mbps, UL 5Mbps)</p>
12	HSPA features	<p>3GPP Release 7</p> <p>UE CAT. 8, 6 for PLS63</p> <p>HSDPA – DL 7.2Mbps</p> <p>HSUPA – UL 5.7Mbps</p> <p>UE CAT. 14, 6 for PLS83</p> <p>HSPA+ – DL 21Mbps</p> <p>HSUPA – UL 5.7Mbps</p> <p>Compressed mode (CM) supported according to 3GPP TS25.212</p>
13	UMTS features	<p>3GPP Release 4</p> <p>PS data rate – 384 kbps DL / 384 kbps UL</p> <p>CS data rate – 64 kbps DL / 64 kbps UL</p>
14	GSM/GPRS/ EGPRS features	<p>GPRS:</p> <ul style="list-style-type: none"> • Multislot Class 12 • Mobile Station Class B • Coding Scheme 1 – 4 <p>EGPRS:</p> <ul style="list-style-type: none"> • Multislot Class 12 • EDGE E2 power class for 8 PSK • Downlink coding schemes – CS 1-4, MCS 1-9

		<ul style="list-style-type: none"> • Uplink coding schemes – CS 1-4, MCS 1-9 • SRB loopback and test mode B • 8-bit, 11-bit RACH • 1 phase/2 phase access procedures • Link adaptation and IR • NACC, extended UL TBF
15	GNSS Features	Protocol: NMEA Modes: Standalone GNSS (GPS, GLONASS, Beidou, Galileo) General: Automatic power saving modes. DC feed bridge and control of power supply for active antenna

By PLS63-W 4G/3G/GSM communication module specification.

4.4 GNSS receiver specifications (Built into PLS63-W)

NO.	Items	Specification performance
1	Model	Chipset integrated gpsOne engine Gen 8C
2	Output format	NMEA-0183 V4.10
3	Impedance	50 Ω
4	Frequency	1575.42 MHz (GLONASS prepared)
5	Accuracy in Open Sky (CEP-50)	< 2m CEP-50 (1Hz tracking)
6	Predicted Orbit Accuracy (CEP-50)	5 meters (1 to 2 days age)
7	TTFF	Cold start : 32s typ. Warm start : 28s typ.
8	Sensitivity	Tracking Sensitivity : -159dBm typ. Acquisition Sensitivity : -147dBm typ. (When using Active antenna or LNA)
9	Total Number of SV Available	~55 SVs

4.5 External I/F specifications

NO.	Items	Specification performance
1	Power control I/F connector	6188-4966 (Sumitomo Wiring Systems)
2	GNSS antenna connector	GT5W-1P-HU (Hirose Electric)

4.5.1 Power control I/F Connector

Pin No.	Terminal name	Remarks
1	BATT	Main battery (8~16V)
2	GND	GND
3	KEY-ON signal	ACC signal
4	CAN RATE	CAN rate setting GND:500kbps Open:250kbps
5	CAN-H	CAN Low-Level Voltage I/O
6	CAN-L	CAN High-Level Voltage I/O

4.5.2 GNSS Antenna Connector

NO.	Terminal name	Remarks
1	RF	Receive
2	GND	GND

5 Outline

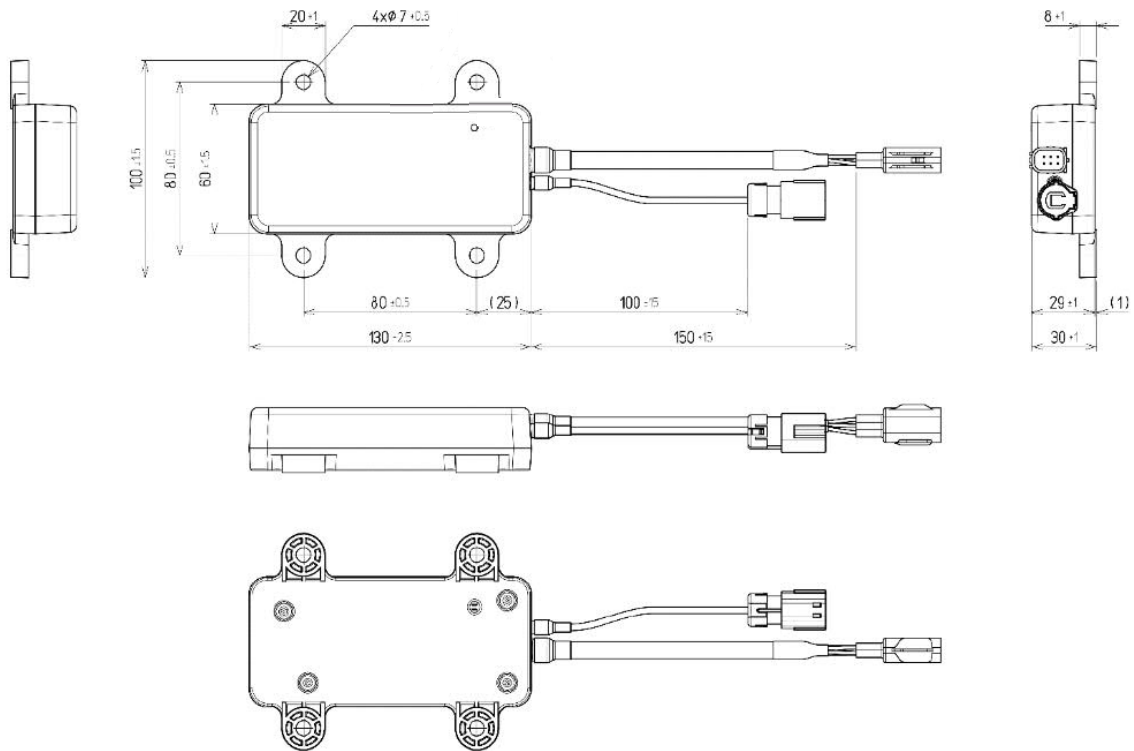

6 Option

6.1 GNSS Antenna

6.1.1 Specification

NO.	Items	Specification performance
1	Antenna model	DAS1595
2	Power supply voltage	3.0V to 5.0V
3	Consumption current	9mA± 3mA (at 3.0V)
4	Cable	RG174
5	Temperature range of operation	-40°C to +85°C
6	Storage temperature range	-40°C to +100°C
7	Received frequency range	GPS:1575.42MHz± 3 MHz GLONASS:1602MHz ± 8 MHz
8	Polarized wave	Right-handed circular polarization
9	LNA Gain	26± 3dB
10	Output impedance	50 ohms
11	OUTPUT VSWR	2.0, or less
12	Connector	GT5W
13	International Protection	IP67

6.1.2 Outline

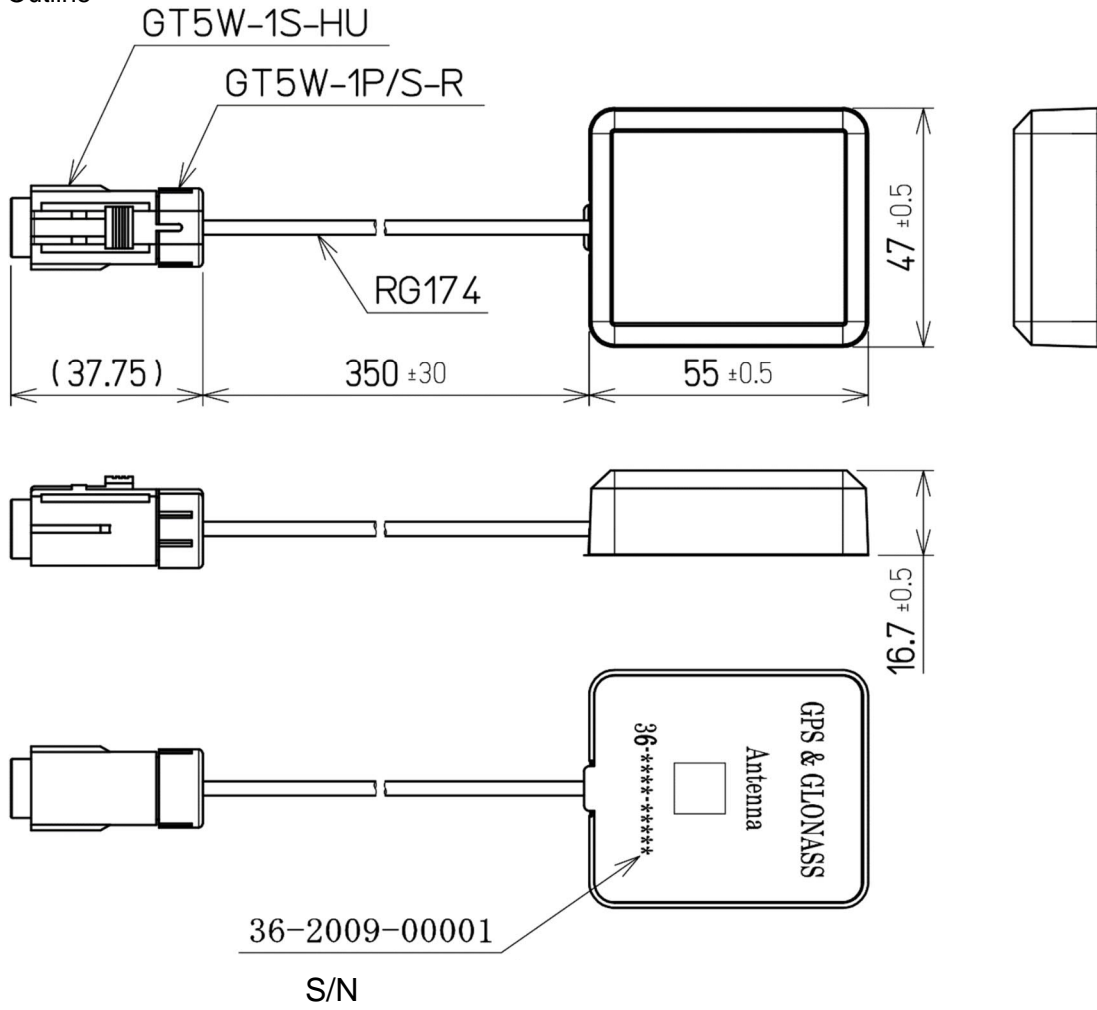

6.2 Communication antenna (Built-in antenna)

6.2.1 Specification

No.	Items	Specification performance
1	Model	CAU-7360TA
2	Antenna type	Chip antenna + Pattern antenna
3	Environmental Regulation	Compliant with RoHS
4	Frequency	699 – 960 MHz 1710 – 2170 MHz 2500 – 2690 MHz
5	Peak gain	699 – 960 MHz : 1.5dBi 1710 – 2170 MHz : 2.3dBi 2500 – 2690 MHz : 2.6dBi It is measured in free space.

7 Handling precautions

7.1 About specification value

Be sure to observe the specification value of this product. Using beyond the specification value may cause a malfunction.



1 Power supply voltage: Main unit (input voltage)

This is the maximum voltage that can be applied between the power supply terminal and the ground terminal (GND). If this voltage is exceeded, a failure may occur.



2 Operating temperature

This is the temperature range within which the operation can be performed with the specifications satisfied. If this temperature range is exceeded, the performance may not be satisfied. It may also cause a malfunction.



3 Storage temperature

This is the temperature range for storage without operation, and performance may not be satisfied if this temperature range is exceeded. It may also cause a malfunction.

7.2 Precautions for use



1 This product is not suitable for use in locations where children are likely to be present.



2 Do not remove or disassemble the screws of this product. Doing so may cause performance deterioration or failure.



3 When performing maintenance with the screws removed, be sure to take measures against static electricity (battery replacement, reset switch operation, etc.). If not doing, it may cause performance degradation or malfunction.



4 Dropping this product or leaving it outdoors for a long time may cause scratches, dirt, or malfunctions.



5 This product is not designed for use in the following special environments.

Do not use in the following special environment as it may cause performance deterioration and failure.

- chemical liquid, organic liquid, etc. adhered or in liquid
 - Locations with a lot of corrosive gases such as salt wind, chlorine, hydrogen sulfide, ammonia, sulfur oxide, hydrogen chloride, and subsulfide gas
 - Environment with strong static electricity and electromagnetic waves
-

-
- 

6 Do not use the product for medical equipment, medical equipment that requires a high degree of safety that affects human life, Space / aviation equipment, Disaster prevention / crime prevention equipment and other equivalent equipment.

 - 

7 Do not use the product near people wearing medical electrical equipment. There is a risk of medical equipment malfunction due to the influence of radio waves.

 - 

8 Depending on the vehicle model, it may affect on-vehicle electronic devices. When installing or wiring, install and wire as far away from the on-vehicle electronic devices as possible. When installing a GNSS antenna, install it as far away as possible from the car navigation system and other antennas. It may cause performance degradation.

 - 

9 Do not damage, break or process each cable. If a heavy object is put on, heated, pulled, or bent forcibly, the cable may be damaged, resulting in a fire or electric shock.

 - 

10 If foreign matter such as water or metal gets inside, first turn off the power of this product, disconnect the power cable, and contact us. Using it as it may cause fire, electric shock or malfunction.

 - 

11 When cleaning the surface, do not use organic solvents such as thinner or benzene. It may cause damage to the paint on the surface. To clean the surface, remove dust and dirt, and wipe with a clean cloth.
-

7.3 Notes on Equipment installation

- 

1 Secure the product by passing the M6 bolts through the mounting holes on the product.

 - 

2 When handling this product, pay sufficient attention to static electricity. It may break down due to static electricity. Be especially careful of static electricity on the interface connector.

 - 

3 Do not use or leave the product in places with high direct sunlight or high temperatures. It may cause overheating, deformation or failure of the equipment.

 - 

4 Please install the main unit, antenna and cable so as not to interfere with operation and operation of equipment such as airbags.

 - 

5 Please securely connect each cable to this product securely. It may cause the cable to come off or damage the connector.

 - 

6 Do not install near devices that generate magnetic fields, such as high-voltage power transmission lines and transformers. The device may not work properly.
-

7.4 Overcurrent protection



- 1 This product does not have a built-in fuse for overcurrent protection. To prevent danger, use an overcurrent protection fuse on the power line.

7.5 Storage precautions



- 1 Avoid locations that generate a lot of corrosive gas such as salt wind, chlorine, hydrogen sulfide, sulfur oxide, hydrogen chloride, and subsulfide gas.



- 2 Condensation will occur in places with rapid temperature and humidity changes. Avoid such an environment and store in a place with little temperature change.



- 3 Do not place the product on an unstable place such as on a wobbling table or tilted. It may fall and cause malfunction or injury.



- 4 Do not store in humid or dusty places. It may cause overheating, ignition or malfunction.

7.6 Carrying method



- 1 Do not throw or drop. This product may be damaged.



- 2 Do not get wet with water. Be careful not to get it wet during transportation during rainfall or snowfall.

7.7 Other



- 1 Please note that we are not liable for any malfunctions or abnormalities that may occur as a result of using this product in a manner that deviates from the contents described in this specification.



- 2 With regard to the equipment described in this specification, parts may be changed to alternative parts within the range that does not impair the electrical, mechanical, and environmental resistance characteristics.



- 3 If the chassis gets too hot to touch with your hands, do not touch the chassis directly, stop using it immediately, and contact our sales department or your local branch / branch / sales office.



- 4 Never perform internal inspections or repairs by the customer. Inspection and repair by non-special maintenance personnel may cause a fire or electric shock. For internal inspection and repair, please ask our sales department or your nearest branch / branch / sales office or agency.

Explanation of symbol mark



Caution

This symbol indicates general cautions, warnings, or dangers that are not specified.







Instruction

This symbol tells the user what general actions are not specified.



Instruction to turn off the power

This symbol indicates that the user should unplug the power plug from the outlet.

	Ban	This symbol indicates a general prohibition notice not specified.
	Disassembly ban	This symbol indicates a prohibition notice when disassembling this product may cause an electric shock or other trouble.
	No touch	This symbol indicates a prohibition notice when injury may occur by touching a specific part of this product under specific conditions.
	Water wet ban	This symbol indicates a prohibition notice when there is a possibility of electric shock or fire due to electric leakage when used in places subject to water, or when wetted, dipped, applied or spilled.

8 Compliance with FCC and IC Rules and Regulations

• FCC

This device complies with Part 15 of the FCC Rules. Operation is subject to the following two conditions: (1) This device may not cause harmful interference, and (2) this device must accept any interference, including interference that may cause undesired operation.

CAUTION:

Any changes or modifications not expressly approved by the party responsible for compliance could void the user's authority to operate the equipment.

NOTE: This equipment has been tested and found to comply with the limits for a Class B digital device, pursuant to part 15 of the FCC Rules. These limits are designed to provide reasonable protection against harmful interference in a residential installation. This equipment generates, uses and can radiate radio frequency energy and, if not installed and used in accordance with the instructions, may cause harmful interference to radio communications. However, there is no guarantee that interference will not occur in a particular installation. If this equipment does cause harmful interference to radio or television reception, which can be determined by turning the equipment off and on, the user is encouraged to try to correct the interference by one or more of the following measures:

- Reorient or relocate the receiving antenna.
- Connect the equipment into an outlet on a circuit different from that to which the receiver is connected.
- Consult the dealer or an experienced radio/TV technician for help.

• IC

This class B digital apparatus with Canadian ICES-003.

Operation is subject to the following two conditions: (1) this device may not cause interference, and (2) this device must accept any interference, including interference that may cause undesired operation of the device.

Cet équipement numérique de classe B est conforme à la norme canadienne NMB-003.

Le présent appareil est conforme aux CNR d'Industrie Canada applicables aux appareils radio exempts de licence. L'exploitation est autorisée aux deux conditions suivantes :

(1) l'appareil ne doit pas produire de brouillage, et (2) l'utilisateur de l'appareil doit accepter tout brouillage radioélectrique subi, même si le brouillage est susceptible d'en compromettre le fonctionnement.

• FCC/IC

RF exposure compliance

- 1) To comply with FCC/IC RF exposure compliance requirements, a separation distance of at least 1 cm must be maintained between the antenna of this device and all persons.
- 2) This transmitter must not be co-located or operating in conjunction with any other antenna or transmitter.

Normes d'exposition RF

- 1) Afin de se conformer aux normes FCC/IC RF exigences de conformité de l'exposition, une distance de séparation d'au moins 1 cm doit être maintenue entre l'antenne de l'appareil et les personnes.
- 2) Cet émetteur ne doit pas être co-localisées ou opérant en conjonction avec une autre antenne ou émetteur.