

<b>Product Name: Smart Phone</b>	<b>Report No:ITEZA2-202400083RF6</b>
<b>Product Model: S punk, S punk Pro, S punk S, S punk E, S punk SE, S punk Plus, S punk Max, S punk Ultra, S cyber, S cyber Pro, S cyber S, S cyber E, S cyber SE, S cyber Plus, S cyber Max, S cyber Ultra</b>	<b>Security Classification: Open</b>
<b>Version: V1.0</b>	<b>Total Page: 32</b>

# TIRT Testing Report

<b>Prepared By:</b>	<b>Checked By:</b>	<b>Approved By:</b>	
Aaron Long	Stone Tang	Joky Wang	
<i>Aaron Long</i>	<i>Stone Tang</i>	<i>Joky Wang</i>	

# RF TEST REPORT

## FCC ID: 2AX4YSPUNK

According to

**47 CFR FCC Part 15, Subpart E(Section 15.407)**

**ANSI C63.10:2013**

Applicant:	Shenzhen DOOGEE Hengtong Technology CO.,LTD
Address:	B, 2/F, Building A4, Silicon Valley Power Digital Industrial Park, No. 22, Longhua New District, Shenzhen, China
Manufacturer:	Shenzhen DOOGEE Hengtong Technology CO.,LTD
Address:	B, 2/F, Building A4, Silicon Valley Power Digital Industrial Park, No. 22, Longhua New District, Shenzhen, China
Sample No:	1000031136
Product Name:	Smart Phone
Brand Name:	DOOGEE
Model No.:	S punk, S punk Pro, S punk S, S punk E, S punk SE, S punk Plus, S punk Max, S punk Ultra, S cyber, S cyber Pro, S cyber S, S cyber E, S cyber SE, S cyber Plus, S cyber Max, S cyber Ultra
Test No.:	S punk

Date of Receipt:	2024/04/09
Date of Test:	2024/04/09~2024/04/25
Issued Date:	2024/04/30
Testing Lab:	TIRT

**Note:** This report shall not be reproduced except in full, without the written approval of Beijing TIRT

Technology Service Co.,Ltd Shenzhen.Laboratory.

This document may be altered or revised by Beijing TIRT Technology Service Co.,Ltd Shenzhen.

Laboratory.Personnel only, and shall be noted in the revision section of the document. The test results

of this report relate only to the tested sample identified in this report.

# Table of Contents

\_Toc163065322

<b>1. General Information .....</b>	<b>5</b>
1.1 Basic Description of Equipment Under Test.....	5
1.2 Description Of Support Units .....	6
1.3 Description Of Support Units .....	6
<b>2. Summary of Test Results .....</b>	<b>7</b>
2.1 Summary of Test Items .....	7
2.2 Application of Standard.....	8
2.3 Test Instruments .....	9
2.4 Operation Mode .....	9
2.5 Test Condition .....	10
2.6 Measurement Uncertainty.....	10
2.7 Test Location.....	11
<b>3. Dynamic Frequency Selection (DFS).....</b>	<b>12</b>
3.1 DFS test requirement.....	12
3.2 DFS Detection Thresholds.....	14
3.3 Radar Test Waveforms.....	15
<b>4. Test Item .....</b>	<b>18</b>
4.1 Calibration of Radar Waveform.....	18
TEST CONFIGURATION .....	18
Test Procedure.....	18
Test Result	18
4.2 Channel Move Time, Channel Closing Transmission Time .....	19
TEST CONFIGURATION .....	19
Test Procedure.....	19
Test Result	20
<b>5. Photos of EUT .....</b>	<b>21</b>
<b>ANNEX A Test Results .....</b>	<b>30</b>



## 1. General Information

### 1.1 Basic Description of Equipment Under Test

Equipment Name	Smart Phone	
Test Model	S punk	
Model Number	S punk, S punk Pro, S punk S, S punk E, S punk SE, S punk Plus, S punk Max, S punk Ultra, S cyber, S cyber Pro, S cyber S, S cyber E, S cyber SE, S cyber Plus, S cyber Max, S cyber Ultra (There is no difference except the name of the model)	
Trademark	DOOGEE	
Power Supply	DC 3.87V from battery or DC 11V from adapter	
EUT Stage	<input type="radio"/> Product Unit	<input checked="" type="radio"/> Final-Sample
Operating Band	5260MHz~5320MHz	<input checked="" type="radio"/> IEEE 802.11a/n/ac(20MHz)
	5500MHz~5700MHz	<input checked="" type="radio"/> IEEE 802.11n/ac(40MHz)
		<input checked="" type="radio"/> IEEE 802.11ac(80MHz)
Modulation technology	OFDM, OFDMA	
Nominal Bandwidth	20MHz / 40MHz / 80MHz	
Modulation Type	IEEE 802.11a: OFDM (BPSK / QPSK / 16QAM / 64QAM) IEEE 802.11n: (BPSK / QPSK / 16QAM / 64QAM) IEEE 802.11ac: (BPSK / QPSK / 16QAM / 64QAM / 256QAM)	
Function	<input type="checkbox"/> Outdoor AP <input type="checkbox"/> Indoor AP <input type="checkbox"/> Fixed P2P <input checked="" type="checkbox"/> Client	
Type of Device	Client device without Radar detection. Do not supported the TPC function	
Antenna Type:	LDS Antenna	
Antenna Gain:	4.0 dBi	

Note:

#: The antenna gain provided by the applicant, and the laboratory will not be responsible for the accumulated calculation results which covers the information provided by the applicant.

According to section 15.31(m), regards to the operating frequency range over 10 MHz, must select three channels which were tested. The Lowest frequency, the middle frequency, and the highest frequency of channel were selected to perform the test, please see the below .

All mode had been tested, this only show the worst mode

Band	Test Channel	20MHz		40MHz		80MHz	
		Channel	Frequency (MHz)	Channel	Frequency (MHz)	Channel	Frequency (MHz)
U-NII-2A	L	52	5260	54	5270	--	--
	M	56	5280	--	--	58	5290
	H	64	5320	62	5310	--	--
U-NII-2C	L	100	5500	102	5510	--	--
	M	136	5680	--	--	106	5530
	H	140	5700	110	5550	--	--

### 1.2 Description Of Support Units

Description	Manufacturer	Model No.	Serial Number	FCC ID	Supplied by
Wireless Router	N/A	N/A	N/A	KA2IRX5460A1	Lab

### 1.3 Description Of Support Units

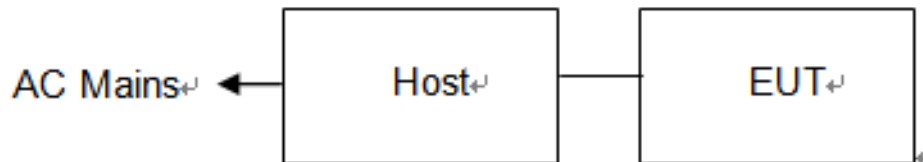

## 2. Summary of Test Results

### 2.1 Summary of Test Items

No.	Description	FCC Part No.	Test Result	Verdict	Remark
1	Calibration of Radar Waveform	15.407(i)	ANNEX A.1	Pass	--
2	Channel Move Time, Channel Closing Transmission Time	15.407(i)	ANNEX A.2	Pass	--

## 2.2 Application of Standard

47 CFR Part 15 Subpart E Section 15.407: Unlicensed National Information Infrastructure Devices

KDB905462 D02 V02: COMPLIANCE MEASUREMENT PROCEDURES FOR UNLICENSED-NATIONAL INFORMATION INFRASTRUCTURE DEVICES OPERATING IN THE 5250-5350 MHz AND 5470-5725 MHz BANDS INCORPORATING DYNAMIC FREQUENCY SELECTION

KDB905462 D04 v01: OPERATIONAL MODES SUGGESTED FOR DFS TESTING

KDB905462 D03 v01r02: U-NII CLIENT DEVICES WITHOUT RADAR DETECTION CAPABILITY

ANSI C63.10:2013: American National Standard for Testing Unlicensed Wireless Devices



## 2.3 Test Instruments

No.	Equipment	Manufacturer	Type No.	Serial No.	Cal. date (yyyy/mm/dd)	Cal. Due date (yyyy/mm/dd)
1	MXA Signal Analyzer	KEYSIGHT	N9020A	MY50410020	2023/11/10	2024/11/09
2	WIDEBAND RADIO COMMUNICATION TESTER	Rohde & Schwarz	CMW500	161997	2023/11/10	2024/11/09
3	ESG VECTOR SIGNAL GENERATOR	Agilent	E4438C	MY45094854	2023/11/10	2024/11/09
4	MXG Vector Signal Generator	Agilent	N5182A	MY46240163	2023/11/18	2024/11/17
5	Adjustable Direct Current Regulated Power Supply	Dongguan Tongmen Electronic Technology Co., LTD	etm-6050c	20211026123	2023/11/10	2024/11/09
6	RF Control Unit	TST	TST-Full	S01	2023/11/10	2024/11/09
7	RF Test software	TST	V2.0	/	2023/11/10	2024/11/09

## 2.4 Operation Mode

The EUT was supplied by and it was run in TX mode that was controlled by client provided RF testing program.

The EUT was transmitted continuously during the test. The worst case test result was showed in the report.

## 2.5 Test Condition

Applicable to	Environmental conditions	Input Power	Tested by
Calibration of Radar Waveform	20.0°C, 56 % RH	120V AC	Stone Tang
Channel Move Time, Channel Closing Transmission Time	24.3°C, 55 % RH	120V AC	Stone Tang

The applicant declare the operating environment of EUT as below:

Normal conditions: 120V AC ,15~35°C

## 2.6 Measurement Uncertainty

Where relevant, the following measurement uncertainty levels have been estimated for tests performed on the EUT.

This uncertainty represents an expanded uncertainty expressed at approximately the 95% confidence level using a coverage factor of k=2.

Uncertainty	
Parameter	Uncertainty
Occupied Channel Bandwidth	±142.12 KHz
RF power conducted	±0.74 dB
RF power radiated	±3.25dB
Spurious emissions, conducted	±1.78dB
Spurious emissions, radiated (9KHz~30MHz)	±2.56dB
Spurious emissions, radiated (30MHz~1GHz)	±4.6dB
Spurious emissions, radiated (Above 1GHz)	±4.9dB
Conduction Emissions(150kHz~30MHz)	±3.1 dB
Humidity	±4.6%
Temperature	±0.7°C
Time	±1.25%

## 2.7 Test Location

Company:	Beijing TIRT Technology Service Co.,Ltd Shenzhen
Address:	104 Building C, Xinmingsheng Industrial Park No.132, Zhangge Old Village East Zone, Zhangge Community, Fucheng Street, Longhua District, Shenzhen, Guangdong, P. R. China
CNAS Registration Number:	CNAS L14158
A2LA Registration Number:	6049.01
FCC Accredited Lab. Designation Number:	CN1366
FCC Test Firm Registration Number:	820690
Telephone:	+86-0755-27087573

### 3. Dynamic Frequency Selection (DFS)

#### 3.1 DFS test requirement

The following table from FCC KDB905462 D02 UNII DFS Compliance procedures new rules list the applicable requirements for the DFS testing.

**Table 1: Applicability of DFS Requirements Prior to Use of a Channel**

Requirement	Operational Mode		
	Master	Client Without Radar Detection	Client With Radar Detection
Non-Occupancy Period	Yes	Not required	Yes
DFS Detection Threshold	Yes	Not required	Yes
Channel Availability Check Time	Yes	Not required	Not required
U-NII Detection Bandwidth	Yes	Not required	Yes

**Table 2: Applicability of DFS requirements during normal operation**

Requirement	Operational Mode	
	Master Device or Client with Radar Detection	Client Without Radar Detection
DFS Detection Threshold	Yes	Not required
Channel Closing Transmission	Yes	Yes
Channel Move Time	Yes	Yes
U-NII Detection Bandwidth	Yes	Not required

Additional requirements for devices with multiple bandwidth modes	Master Device or Client with Radar Detection	Client Without Radar Detection
U-NII Detection Bandwidth and Statistical Performance Check	All BW modes must be tested	Not required
Channel Move Time and Channel Closing Transmission Time	Test using widest BW mode available	Test using the widest BW mode available for the link
All other tests	Any single BW mode	Not required

Note: Frequencies selected for statistical performance check (Section 7.8.4) should include several frequencies within the radar detection bandwidth and frequencies near the edge of the radar detection bandwidth. For 802.11 devices it is suggested to select frequencies in each of the bonded 20 MHz channels and the channel center frequency.

## **Master Devices**

- a) The Master Device will use DFS in order to detect Radar Waveforms with received signal strength above the DFS Detection Threshold in the 5250~5350 MHz and 5470~5725 MHz bands. DFS is not required in the 5150~5250 MHz or 5725~5825 MHz bands.
- b) Before initiating a network on a Channel, the Master Device will perform a Channel Availability Check for a specified time duration (Channel Availability Check Time) to ensure that there is no radar system operating on the Channel, using DFS described under subsection a) above.
- c) The Master Device initiates a U-NII network by transmitting control signals that will enable other U-NII devices to Associate with the Master Device.
- d) During normal operation, the Master Device will monitor the Channel (In-Service Monitoring) to ensure that there is no radar system operating on the Channel, using DFS described under a).
- e) If the Master Device has detected a Radar Waveform during In-Service Monitoring as described under d), the Operating Channel of the U-NII network is no longer an Available Channel. The Master Device will instruct all associated Client Device(s) to stop transmitting on this Channel within the Channel Move Time. The transmissions during the Channel Move Time will be limited to the Channel Closing Transmission Time.
- f) Once the Master Device has detected a Radar Waveform it will not utilize the Channel for the duration of the Non-Occupancy Period.
- g) If the Master Device delegates the In-Service Monitoring to a Client Device, then the combination will be tested to the requirements described under d) through f) above.

## **Client Devices**

- a) A Client Device will not transmit before having received appropriate control signals from a Master Device.
- b) A Client Device will stop all its transmissions whenever instructed by a Master Device to which it is associated and will meet the Channel Move Time and Channel Closing Transmission Time requirements. The Client Device will not resume any transmissions until it has again received control signals from a Master Device.
- c) If a Client Device is performing In-Service Monitoring and detects a Radar Waveform above the DFS Detection Threshold, it will inform the Master Device. This is equivalent to the Master Device detecting the Radar Waveform and d) through f) of section 5.1.1 apply.
- d) Irrespective of Client Device or Master Device detection the Channel Move Time and Channel Closing Transmission Time requirements remain the same.
- e) The client test frequency must be monitored to ensure no transmission of any type has occurred for 30 minutes. Note: If the client moves with the master, the device is considered compliant if nothing appears in the client non-occupancy period test. For devices that shut down (rather than moving channels), no beacons should appear.

**Table 4: DFS Response Requirement Values**

Parameter	Value
Non-occupancy period	Minimum 30 minutes
Channel Availability Check Time	60 seconds
Channel Move Time	10 seconds See Note 1.
Channel Closing Transmission Time	200 milliseconds + an aggregate of 60 milliseconds over remaining 10 second period. See Notes 1 and 2.
U-NII Detection Bandwidth	Minimum 100% of the U-NII 99% transmission power bandwidth. See Note 3.
<p>Note 1: Channel Move Time and the Channel Closing Transmission Time should be performed with Radar Type 0. The measurement timing begins at the end of the Radar Type 0 burst.</p> <p>Note 2: The Channel Closing Transmission Time is comprised of 200 milliseconds starting at the beginning of the Channel Move Time plus any additional intermittent control signals required facilitating a Channel move (an aggregate of 60 milliseconds) during the remainder of the 10 second period. The aggregate duration of control signals will not count quiet periods in between transmissions.</p> <p>Note 3: During the U-NII Detection Bandwidth detection test, radar type 0 should be used. For each frequency step the minimum percentage of detection is 90 percent. Measurements are performed with no data traffic.</p>	

### 3.2 DFS Detection Thresholds

**Table 3: DFS Detection Thresholds for Master Devices and Client Devices With Radar Detection**

Maximum Transmit Power	Value (See Notes 1, 2, and 3)
EIRP ≥ 200 milliwatt	-64 dBm
EIRP < 200 milliwatt and power spectral density < 10 dBm/MHz	-62 dBm
EIRP < 200 milliwatt that do not meet the power spectral density requirement	-64 dBm
<p>Note 1: This is the level at the input of the receiver assuming a 0 dBi receive antenna.</p> <p>Note 2: Throughout these test procedures an additional 1 dB has been added to the amplitude of the test transmission waveforms to account for variations in measurement equipment. This will ensure that the test signal is at or above the detection threshold level to trigger a DFS response.</p>	

### 3.3 Radar Test Waveforms

This section provides the parameters for required test waveforms, minimum percentage of successful detections, and the minimum number of trials that must be used for determining DFS conformance. Step intervals of 0.1 microsecond for Pulse Width, 1 microsecond for PRI, 1 MHz for chirp width and 1 for the number of pulses will be utilized for the random determination of specific test waveforms.

**Table 5 Short Pulse Radar Test Waveforms**

Radar Type	Pulse Width (μsec)	PRI (μsec)	Number of Pulses	Minimum Percentage of Successful	Minimum Number of
0	1	1428	18	See Note 1	See Note 1
1	1	Test A: 15 unique PRI values randomly selected from the list of 23 PRI values in Table 5a	Roundup $\left\{ \left( \frac{1}{360} \right) \cdot \left( \frac{19 \cdot 10^6}{PRI_{\mu\text{SEC}}} \right) \right\}$	60%	30
		Test B: 15 unique PRI values randomly selected within the range of 518-3066 μsec, with a minimum increment of 1 μsec, excluding PRI values selected in Test A			
2	1-5	150-230	23-29	60%	30
3	6-10	200-500	16-18	60%	30
4	11-20	200-500	12-16	60%	30
Aggregate (Radar Types 1-4)				80%	120
Note 1: Short Pulse Radar Type 0 should be used for the detection bandwidth test, channel move time, and channel closing time tests.					

A minimum of 30 unique waveforms are required for each of the Short Pulse Radar Types 2 through 4. If more than 30 waveforms are used for Short Pulse Radar Types 2 through 4, then each additional waveform must also be unique and not repeated from the previous waveforms. If more than 30 waveforms are used for Short Pulse Radar Type 1, then each additional waveform is generated with Test B and must also be unique and not repeated from the previous waveforms in Tests A or B.

For example if in Short Pulse Radar Type 1 Test B a PRI of 3066 μsec is selected, the number of pulses would

be Round up  $\left\{ \left( \frac{1}{360} \right) \cdot \left( \frac{19 \cdot 10^6}{3066} \right) \right\} = \text{Round up } \{17.2\} = 18.$

**Table 5a - Pulse Repetition Intervals Values for Test A**

Pulse Repetition Frequency Number	Pulse Repetition Frequency (Pulses Per Second)	Pulse Repetition Interval (Microseconds)
1	1930.5	518
2	1858.7	538
3	1792.1	558
4	1730.1	578
5	1672.2	598
6	1618.1	618
7	1567.4	638
8	1519.8	658
9	1474.9	678
10	1432.7	698
11	1392.8	718
12	1355	738
13	1319.3	758
14	1285.3	778
15	1253.1	798
16	1222.5	818
17	1193.3	838
18	1165.6	858
19	1139	878
20	1113.6	898
21	1089.3	918
22	1066.1	938
23	326.2	3066

**Table 6 – Long Pulse Radar Test Waveform**

Radar Type	Pulse Width (µsec)	Chirp Width (MHz)	PRI (µsec)	Number of Pulses per Burst	Number of Bursts	Minimum Percentage of Successful	Minimum Number of Trials
5	50-100	5-20	1000-2000	1-3	8-20	80%	30

The parameters for this waveforms are randomly chosen. Thirty unique waveforms are required for the Long Pulse Radar Type waveforms. If more than 30 waveforms are used for the Long Pulse Radar Type wave forms, then each additional waveform must also be unique and not repeated from the previous waveforms.



**Table 7 – Frequency Hopping Radar Test Waveform**

Radar Type	Pulse Width (μsec)	PRI (μsec)	Pulses per Hop	Hopping Rate (kHz)	Hopping Sequence Length (msec)	Minimum Percentage of Successful	Minimum Number of Trials
6	1	333	9	0.333	300	70%	30

For the Frequency Hopping Radar Type, the same Burst parameters are used for each wave form. The hopping sequence is different for each wave form and a 100-length segment is selected from the hopping sequence defined by the following algorithm:

The first frequency in a hopping sequence is selected randomly from the group of 475 integer frequencies from 5250–5724MHz. Next, the frequency that was just chosen is removed from the group and a frequency is randomly selected from the remaining 474 frequencies in the group. This process continues until all 475 frequencies are chosen for the set. For selection of a random frequency, the frequencies remaining within the group are always treated as equally likely.

## 4. Test Item

### 4.1 Calibration of Radar Waveform

#### TEST CONFIGURATION

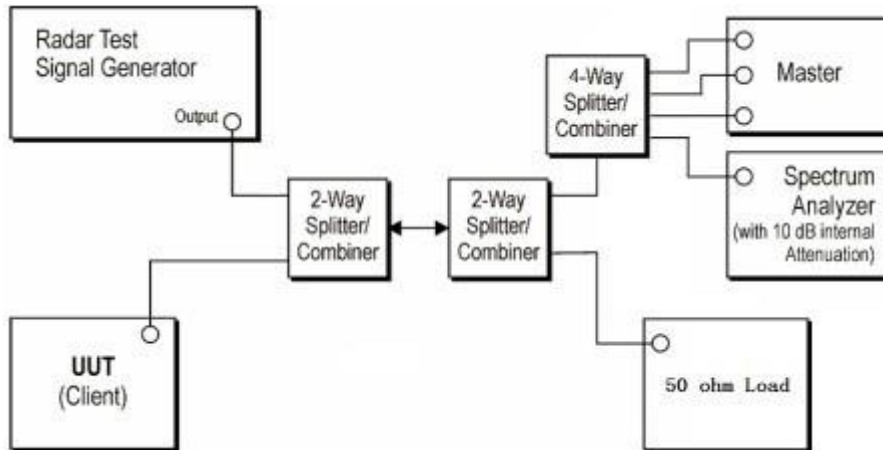

#### Test Procedure

- a) A 50 ohm load is connected in place of the spectrum analyzer, and the spectrum analyzer is connected to place of the master
- b) The interference Radar Detection Threshold Level is  $-62\text{dBm} + 0\text{dBi} + 1\text{dB} = -61\text{dBm}$  that had been taken into account the output power range and antenna gain.
- c) The following equipment setup was used to calibrate the conducted radar waveform. A vector signal generator was utilized to establish the test signal level for radar type 0. During this process there were no transmissions by either the master or client device. The spectrum analyzer was switched to the zero spans (time domain) at the frequency of the radar waveform generator. Peak detection was used. The spectrum analyzer resolution bandwidth (RBW) and video bandwidth (VBW) were set to 3MHz. The spectrum analyzer had offset  $-1.0\text{dB}$  to compensate RF cable loss  $1.0\text{dB}$ .
- d) The vector signal generator amplitude was set so that the power level measured at the spectrum analyzer was  $-62\text{dBm} + 0\text{dBi} + 1\text{dB} = -61\text{dBm}$ . Capture the spectrum analyzer plots on short pulse radar waveform.

#### Test Result

Please refer to ANNEX A.1

## 4.2 Channel Move Time, Channel Closing Transmission Time

### TEST CONFIGURATION

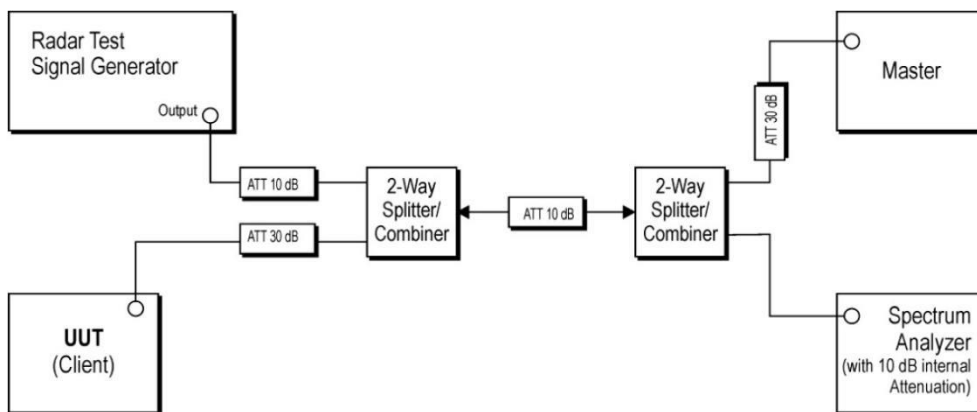

### Test Procedure

- a) The radar pulse generator is setup to provide a pulse at frequency that the master and client are operating. A type 0 radar pulse with a 1us pulse width and a 1428us PRI is used for the testing.
- b) The vector signal generator is adjusted to provide the radar burst (18 pulses) at the level of approximately -61dBm at the antenna port of the master device.
- c) A trigger is provided from the pulse generator to the DFS monitoring system in order to capture the traffic and the occurrence of the radar pulse.
- d) EUT will associate with the master at channel. The file "iperf.exe" specified by the FCC is streamed from the PC 2 through the master and the client device to the PC 1 and played in full motion video using Media Player Classic Ver. 6.4.8.6 in order to properly load the network for the entire period of the test.
- e) When radar burst with a level equal to the DFS Detection Threshold +1dB is generated on the operating channel of the U-NII device. At time T0 the radar waveform generator sends a burst of pulse of the radar waveform at Detection Threshold +1dB.
- f) Observe the transmissions of the EUT at the end of the radar Burst on the Operating Channel Measure and record the transmissions from the UUT during the observation time (Channel Move Time). One 15 seconds

plot is reported for the Short Pulse Radar Type 0. The plot for the Short Pulse Radar Types start at the end of the radar burst. The Channel Move Time will be calculated based on the zoom in 600ms plot of the Short Pulse Radar Type

- g) Measurement of the aggregate duration of the Channel Closed Transmission Time method. With the spectrum analyzer set to zero span tuned to the center frequency of the EUT operating channel at the radar simulated frequency, peak detection, and max hold, the dwell time per bin is given by:  $Dwell (0.3ms) = S (12000ms) / B (4000)$ ; where Dwell is the dwell time per spectrum analyzer sampling bin, S is sweep time and B is the number of spectrum analyzer sampling bins. An upper bound of the aggregate duration of the intermittent control signals of Channel Closing Transmission Time is calculated by:  $C (ms) = N \times Dwell (0.3ms)$ ; where C is the Closing Time, N is the number of spectrum analyzer sampling bins (intermittent control signals) showing a U-NII transmission and Dwell is the dwell time per bin.
- h) Measurement the EUT for more than 30 minutes following the channel move time to verify that no transmission or beacons occur on this channel.

## Test Result

Please refer to ANNEX A.2

### 5. Photos of EUT















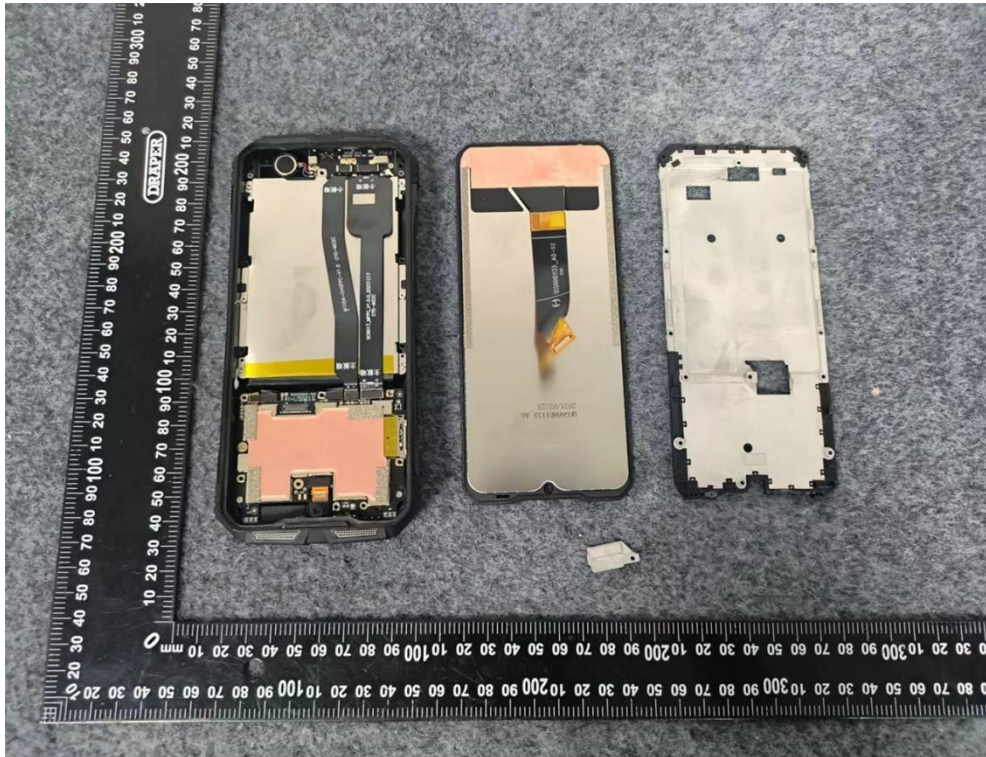



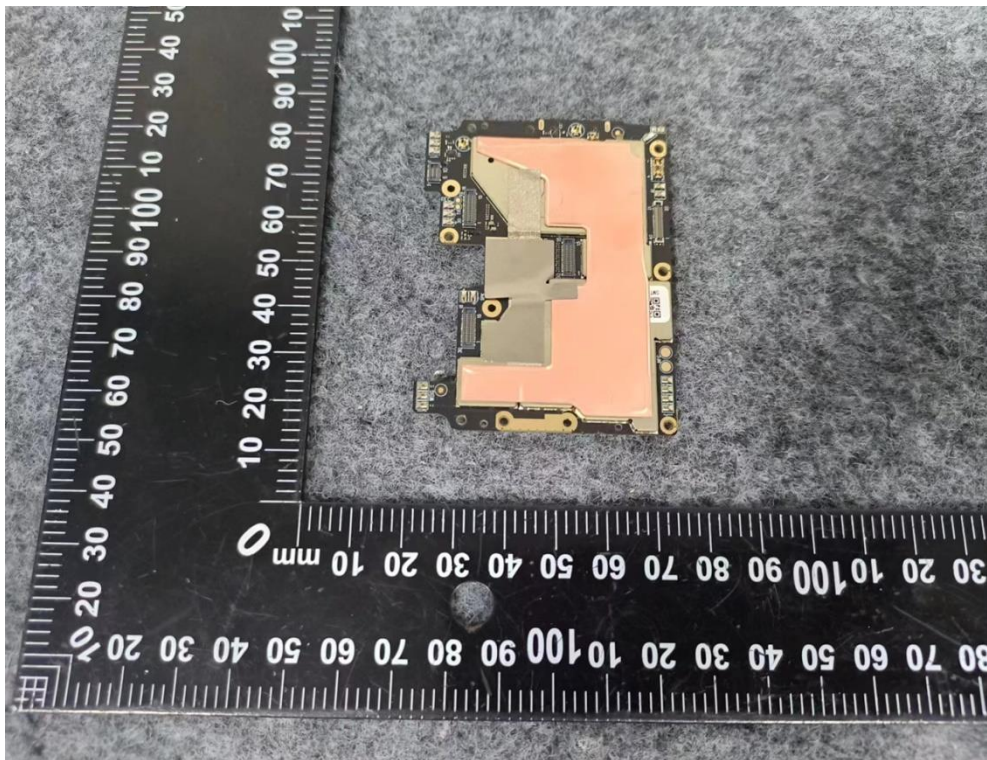
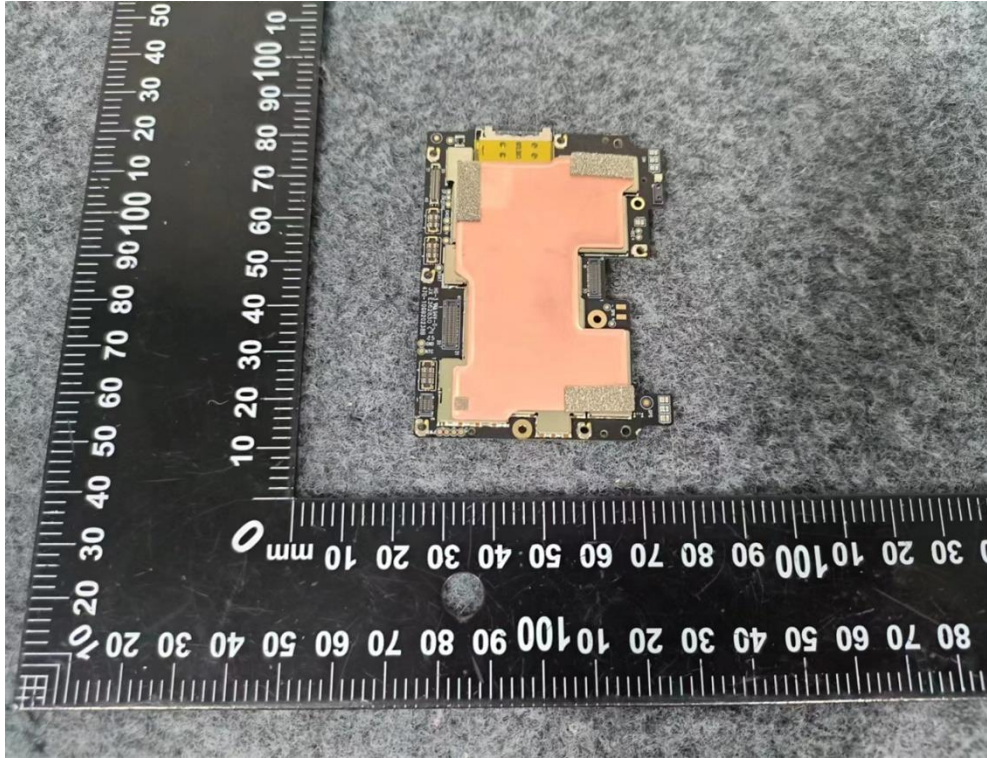



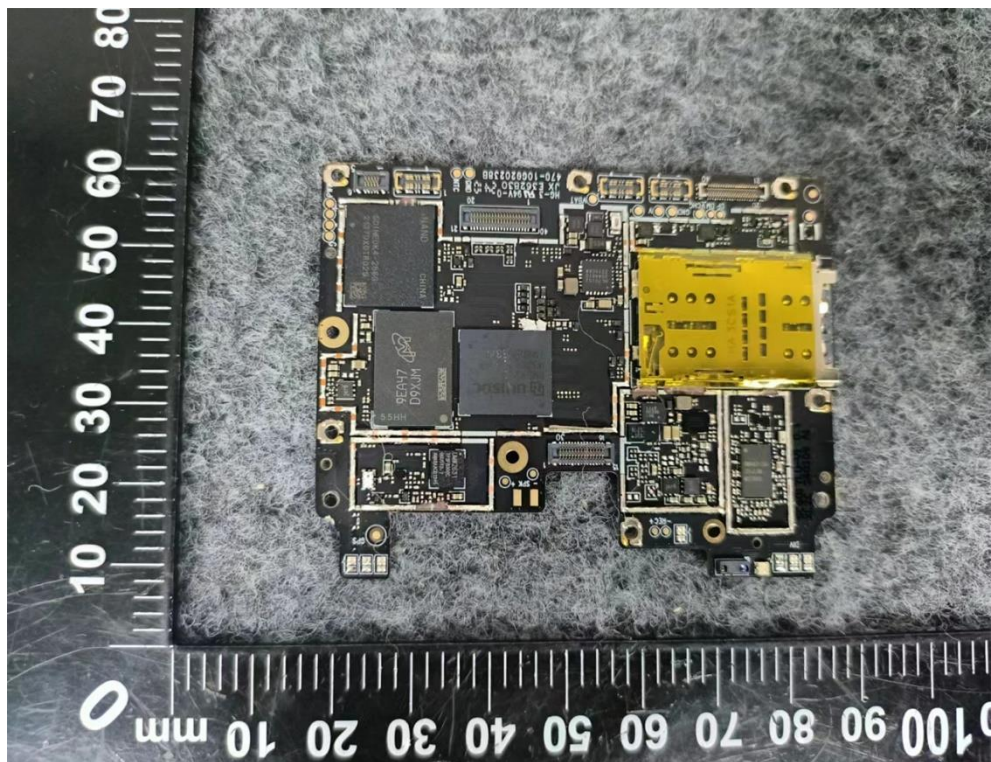
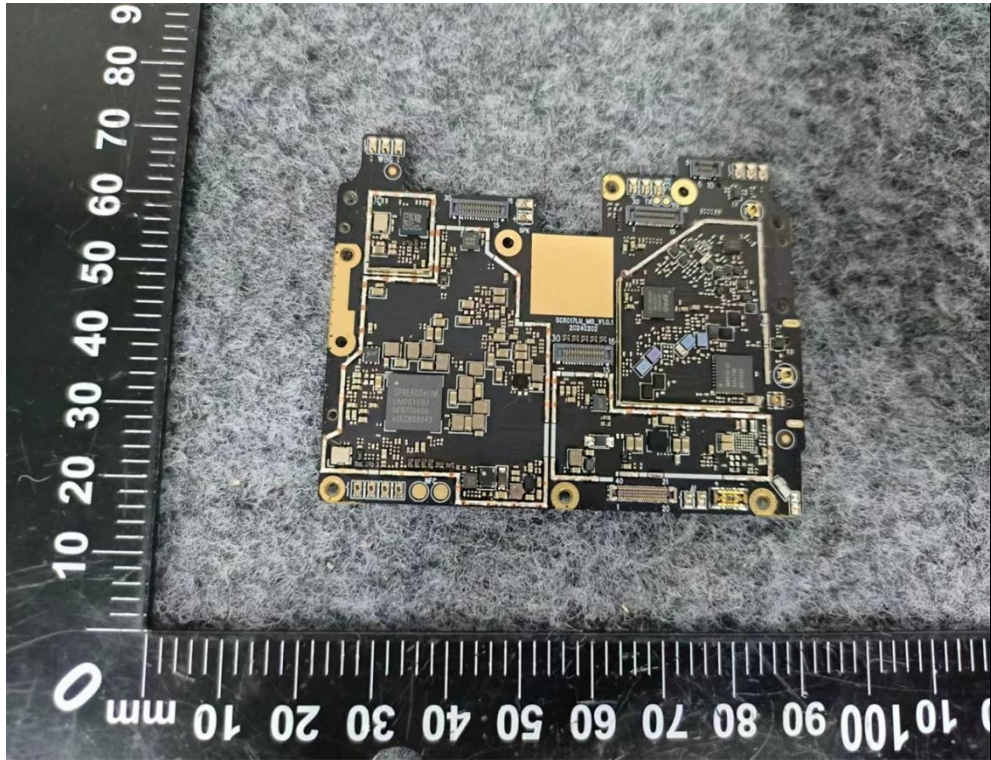



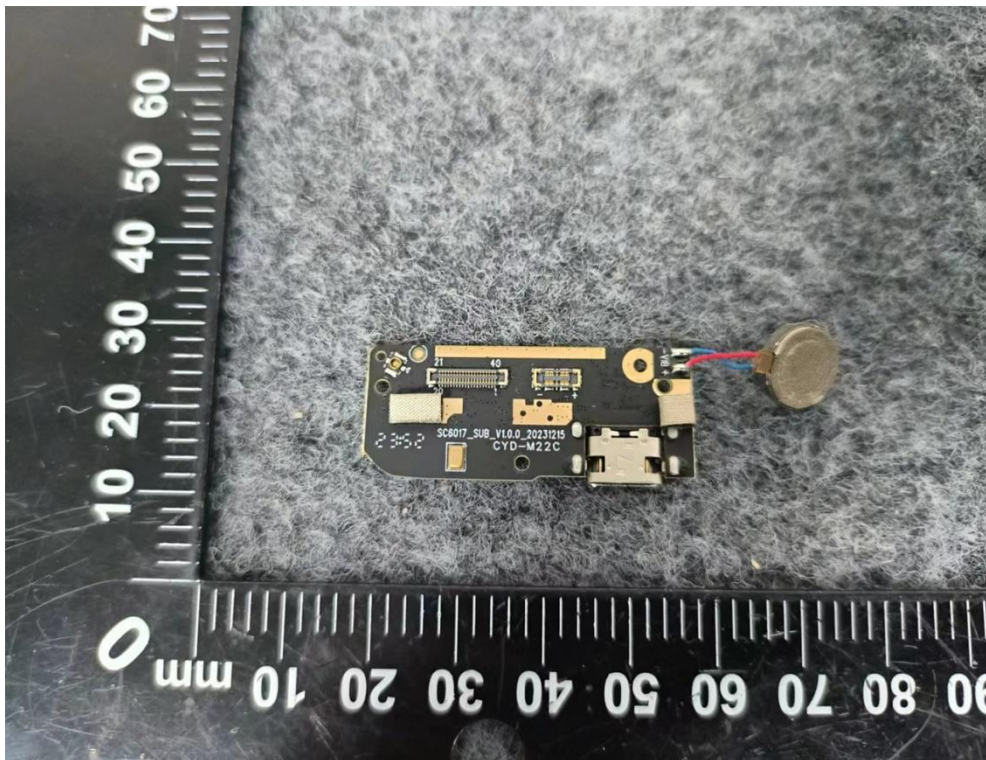
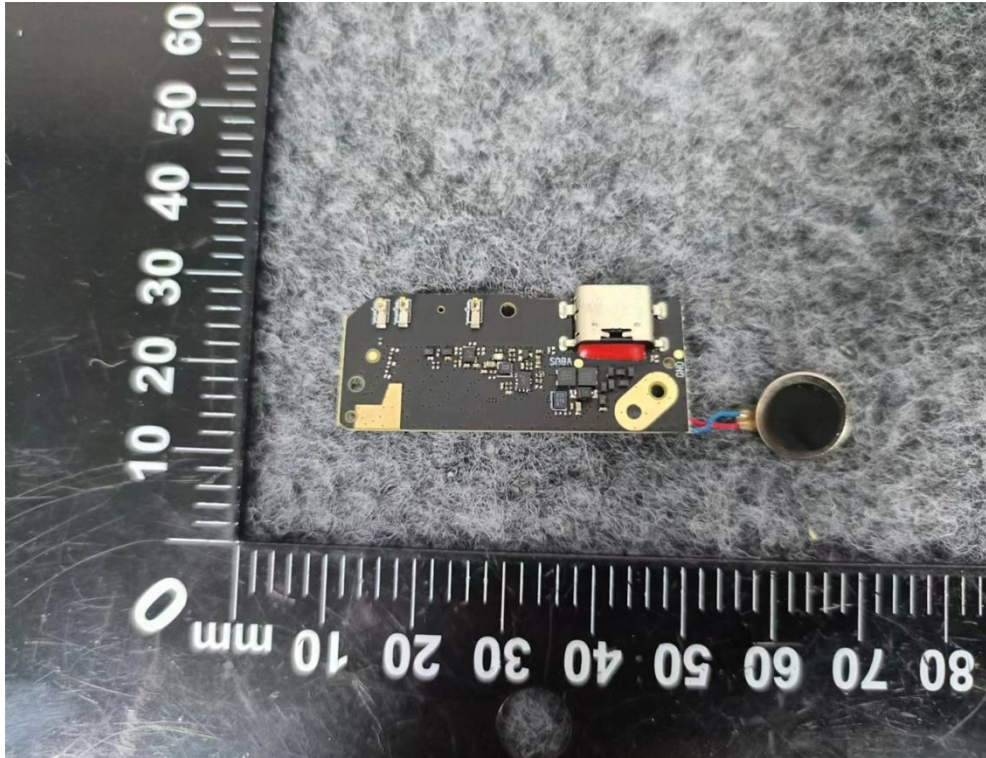



# ANNEX A Test Results

## 1. Signal Calibration

### 1.1 SC

#### 1.1.1 Test Result

Band: 2A							
Mode	Bandwidth (MHz)	Frequency (MHz)	Radar Signal		Signal Calibration		Verdict
			Type	Trial Id	Result	Limit	
802.11a	20	5260	0	0	Refer To Test Graph		Pass
			1	0	Refer To Test Graph		Pass
			2	0	Refer To Test Graph		Pass
			3	0	Refer To Test Graph		Pass
			4	0	Refer To Test Graph		Pass
			5	0	Refer To Test Graph		Pass
			6	0	Refer To Test Graph		Pass

#### 1.1.2 Test Graph

Signal Calibration\_802.11a\_2A\_5260MHz\_RadarType0\_Trial0

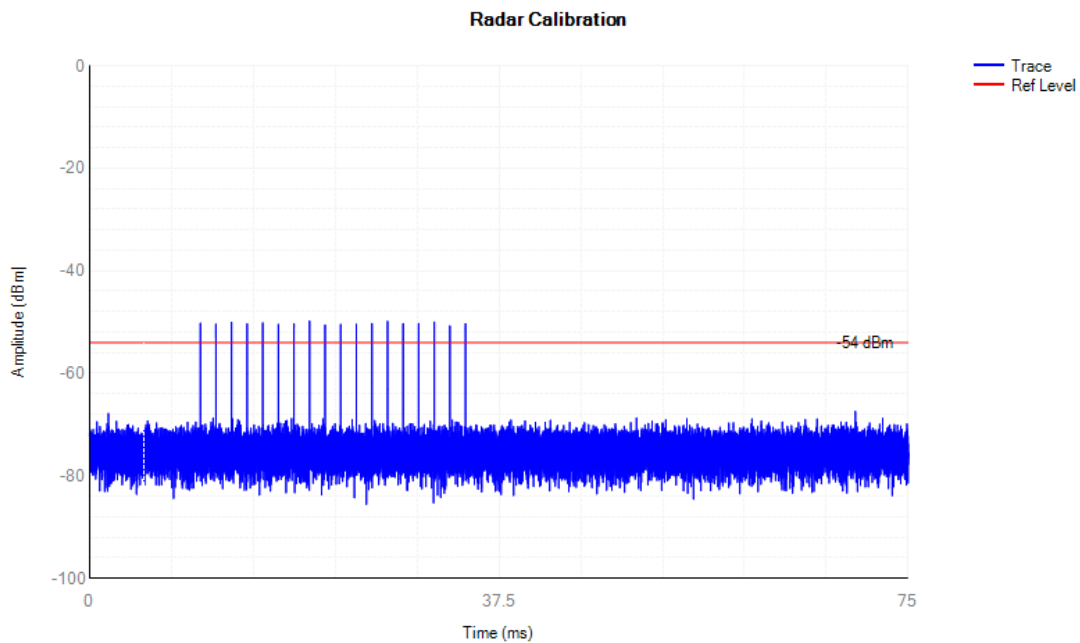

Note: Only display data Radar Type 0 and Trial 0 mode

## 2. Channel Loading (Payload)

### 2.1 Payload

#### 2.1.1 Test Result

Band: 2A, Band: 2C					
Mode	Bandwidth (MHz)	Frequency (MHz)	Channel Loading (Payload) (%)		Verdict
			Result	Limit	
802.11a	20	5260	93.77	>=17	Pass

#### 2.1.2 Test Graph

Channel Loading (Payload)\_802.11a\_2A\_5260MHz

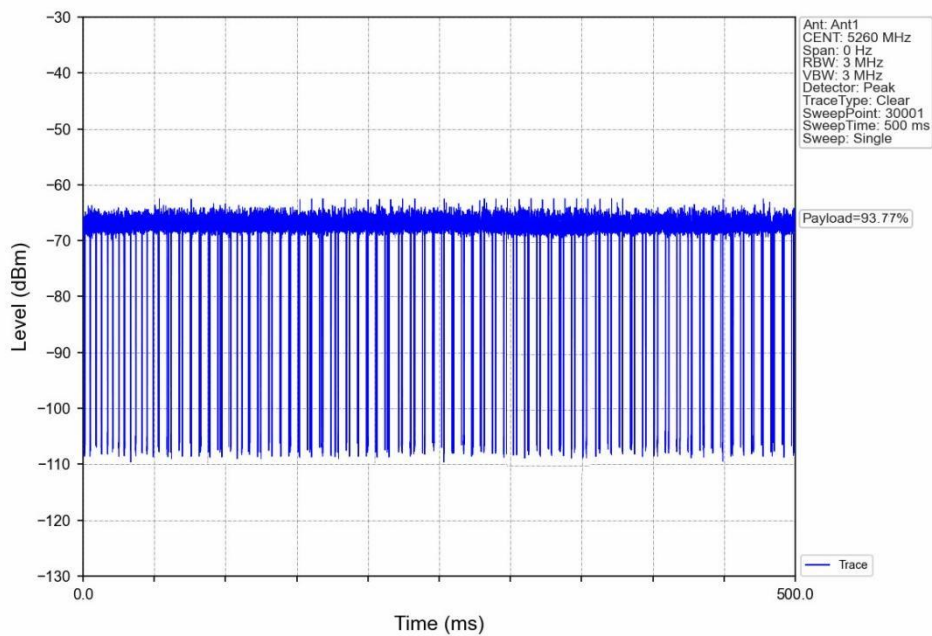

### 3. Channel Move Time and Closing Transmission Time

#### 3.1 CMT\_CTT

##### 3.1.1 Test Result

Band: 2A							
Mode	Bandwidth (MHz)	Frequency (MHz)	Channel Move Time		Closing Transmission Time		Verdict
802.11a	20	5260	Result	1.9s	Result	200 ms +4.1 ms	Pass
			Limit	< 10s	Limit	< 260ms	

##### 3.1.2 Test Graph

Channel Move Time and Closing Transmission Time\_802.11a\_2A\_5260MHz

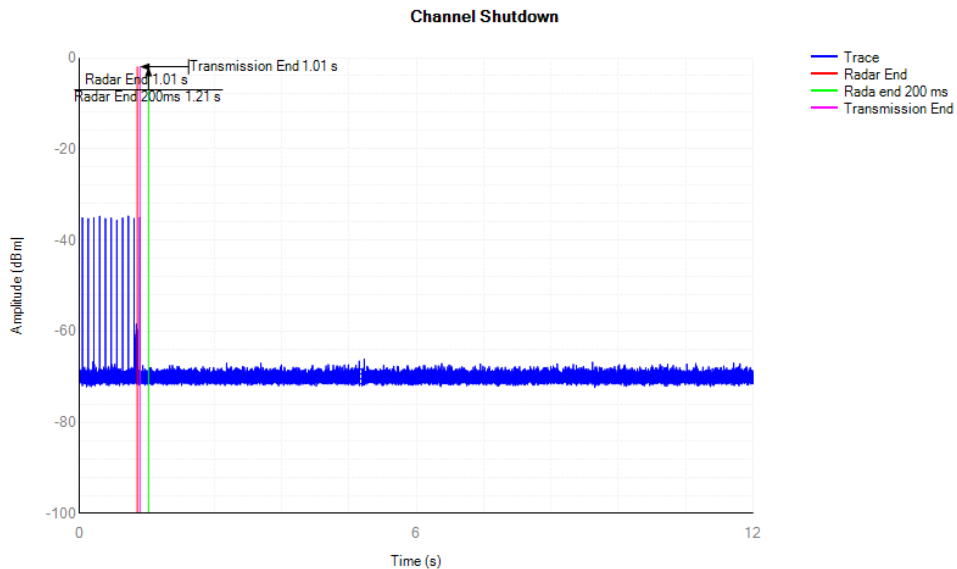

### 4. The time for slave and master complete its power-on cycle

The time for EUT to complete its power-on cycle is 0.7 S.

The time for AP to complete its power-on cycle is 170.1 S.

END OF REPORT