



## P/N: HY160808 SRF07

### Features

1. Surface mounted devices with a small dimension of  $1.6 \times 0.8 \times 0.8$  mm meet future miniaturization trend.
2. Embedded and LTCC (low temperature co-fired ceramic) technology is able to integrate with system design as well as beautifying the housing of final product.
3. High stability and low tolerance.

### Applications

1. Bluetooth
2. Wireless LAN
3. ISM band 2.4GHz wireless applications

### Dimensions (Unit: mm)

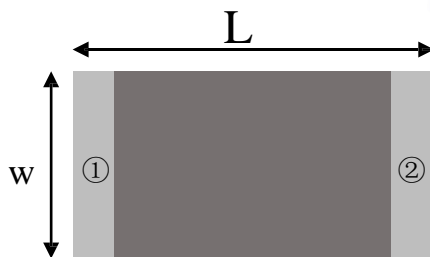

( Top View )

Number	Terminal Name
①	INPUT
②	NC

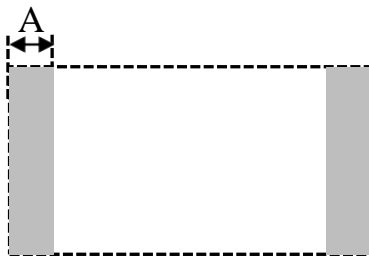

( Bottom View )

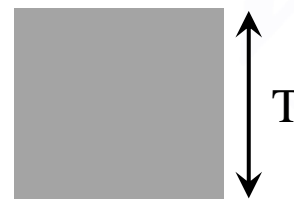

( Side View )

Symbols	L	W	T	A
Dimensions	$1.60 \pm 0.20$	$0.80 \pm 0.20$	$0.80 \pm 0.20$	$0.30 \pm 0.10$



## P/N: HY160808 SRF07

### Electrical Characteristics

	Feature	Specification
1	Central frequency	2.45GHz&5.5GHz
2	Bandwidth	>100MHz
3	Peak gain	>3dBi
4	VSWR	<2
5	Polarization	Linear
6	Azimuth beamwidth	Omnidirectional
7	Impedance	50 $\Omega$

### Characteristic Curves

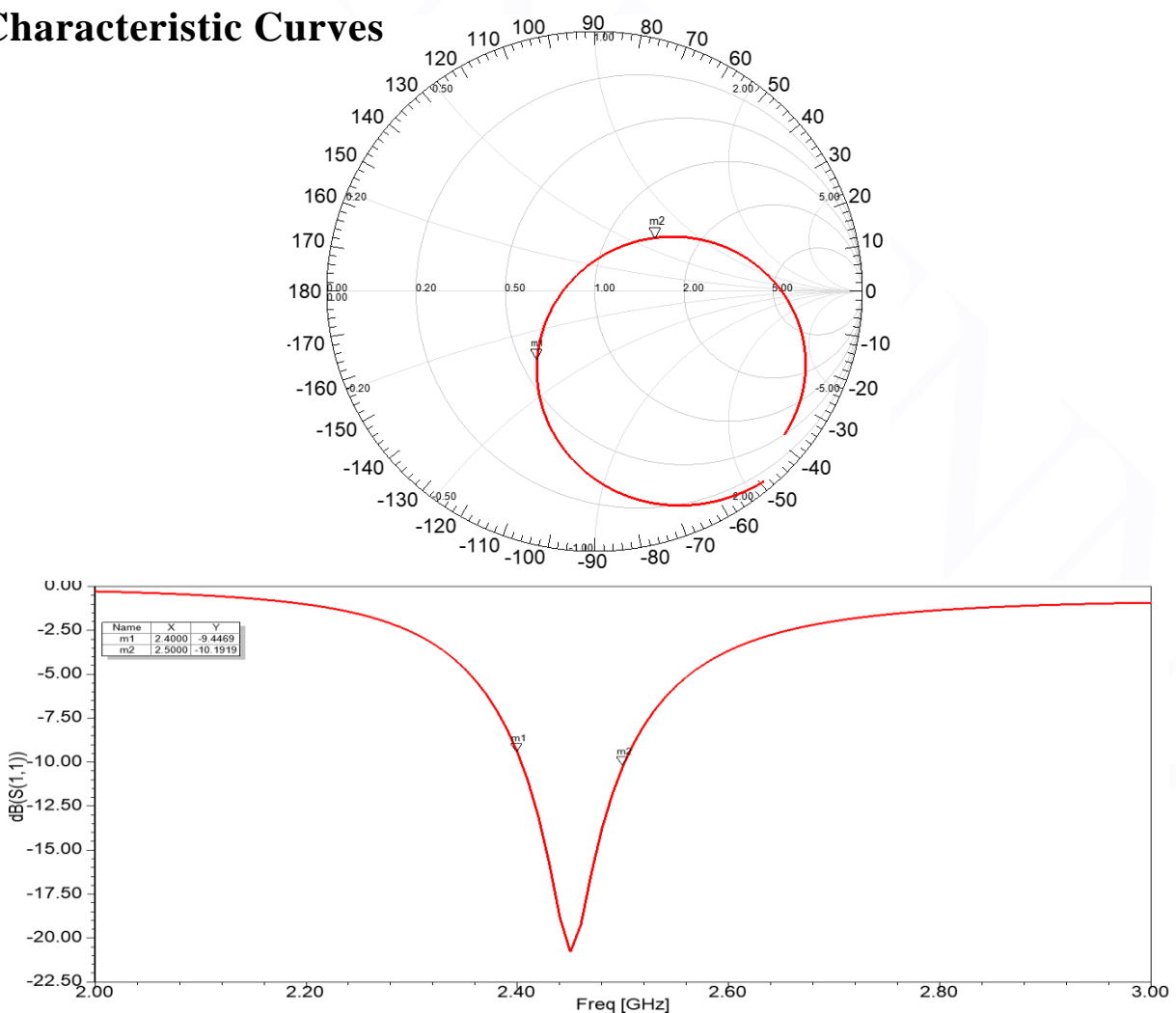

Hanyang Antenna Design Co. Ltd. has possession of proprietary information provided in this report and this proprietary information shall be kept in strict confidence and not disclosed to any person or firm without the prior written consent of Hanyang Antenna Design Co. Ltd.



## P/N: HY160808 SRF07

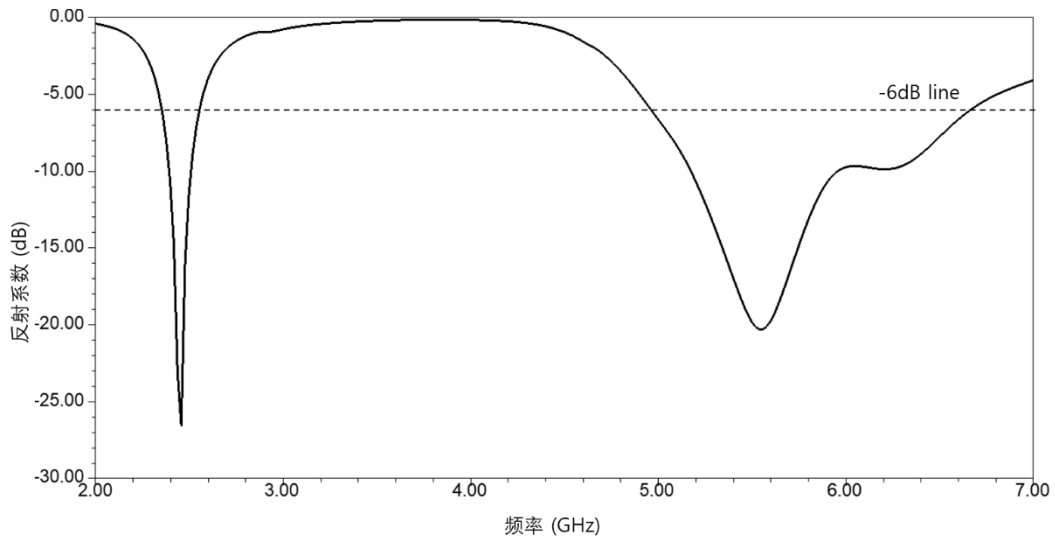

### Radiation Pattern

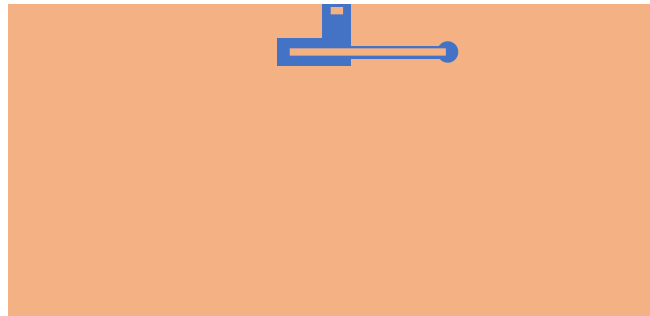
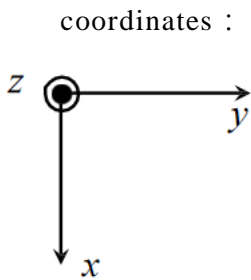

Y-Z Plane

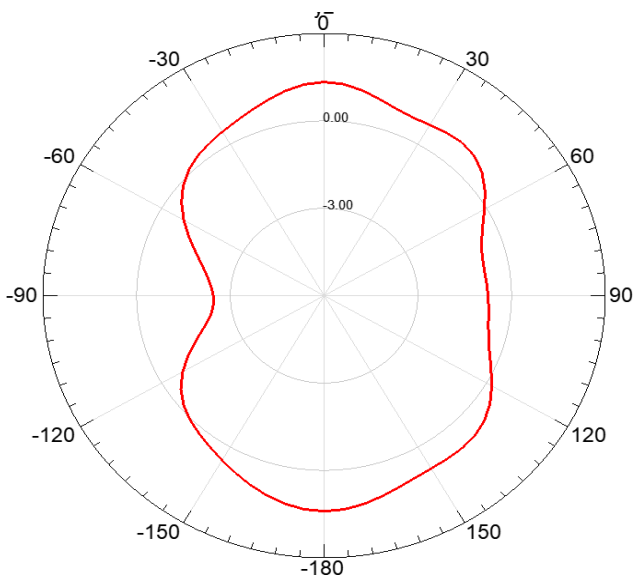

X-Z Plane

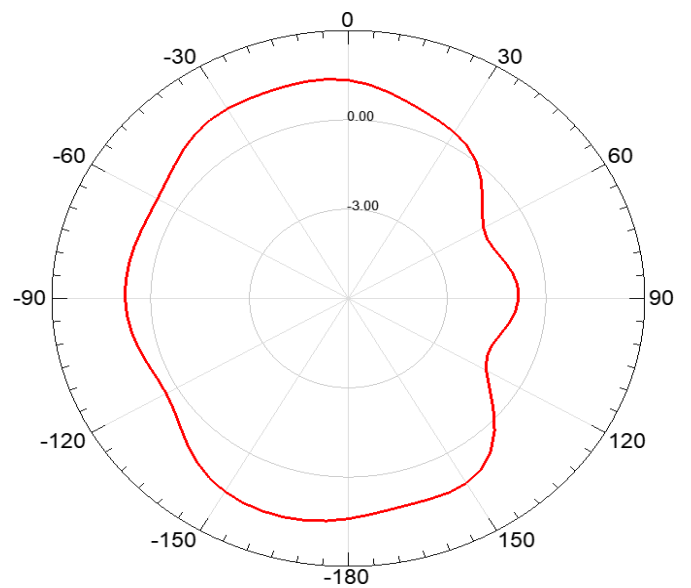

Hanyang Antenna Design Co. Ltd. has possession of proprietary information provided in this report and this proprietary information shall be kept in strict confidence and not disclosed to any person or firm without the prior written consent of Hanyang Antenna Design Co. Ltd.



**P/N: HY160808 SRF07**

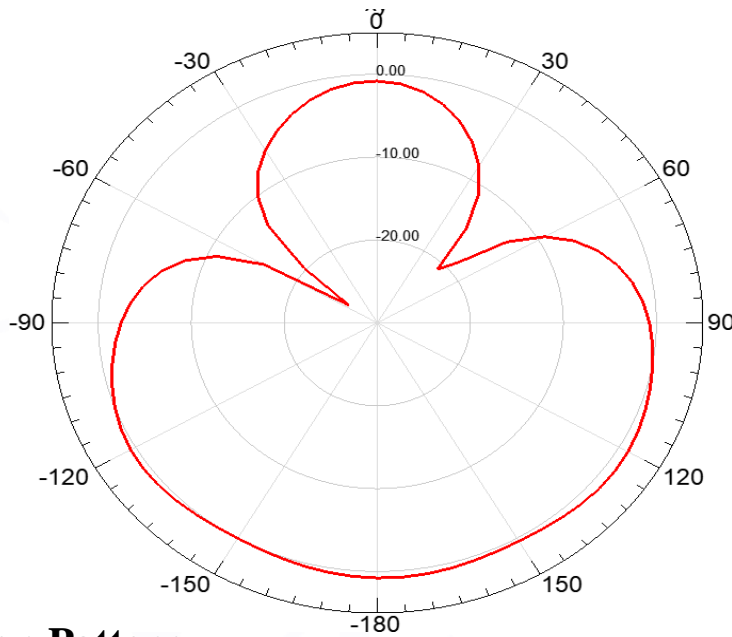

**3D Radiation Pattern**

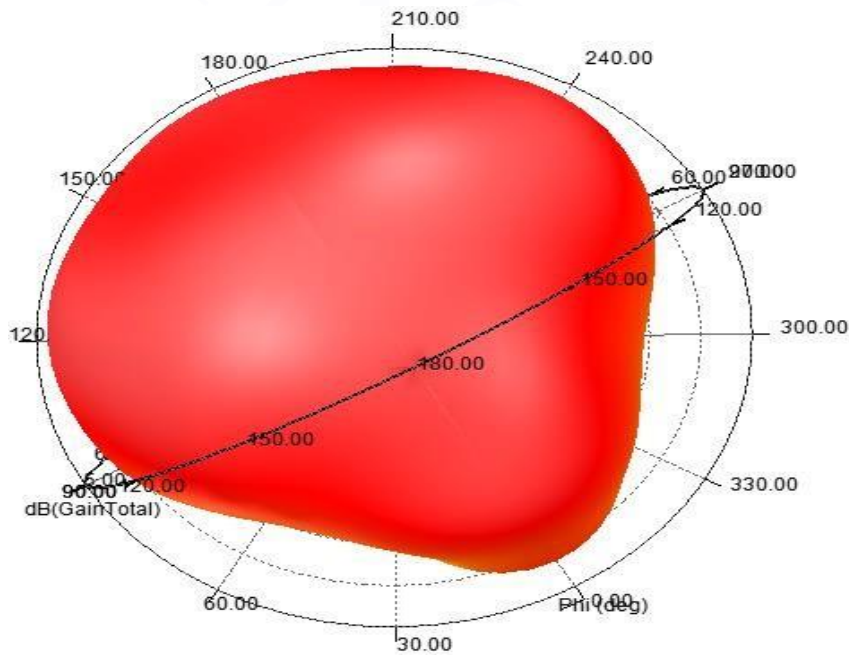

Frequency	2450MHz	5500MHz
Avg. gain	-0.85	-1.30
Peak gain	3.0	3.5
Efficiency	82%	78%

Hanyang Antenna Design Co. Ltd. has possession of proprietary information provided in this report and this proprietary information shall be kept in strict confidence and not disclosed to any person or firm without the prior written consent of Hanyang Antenna Design Co. Ltd.



## P/N: HY160808 SRF07

### Dependability Test

Test Temperature	25°C ± 3°C
Operating Temperature	-25°C ~ +85°C
Temperature	5~40°C
Relative Humidity	20~70%

### Moisture Proof

Temperature: 40 ± 2°C Humidity: 90~95%RH  
 Duration: 500h  
 Recovery conditions: Room temperature Recovery Time: 24h (Class1) or 48h (Class2)

### Solderability

At least 95% of the terminal electrode is covered by new solder.  
 Preheating conditions: 80 to 120°C; 10~30s.  
 Solder Temperature: 235 ± 5°C Duration: 2 ± 0.5s, Solder Temperature: 245 ± 5°C Duration: 2 ± 0.5s

### Optimum Solder Amount for Reflow Soldering

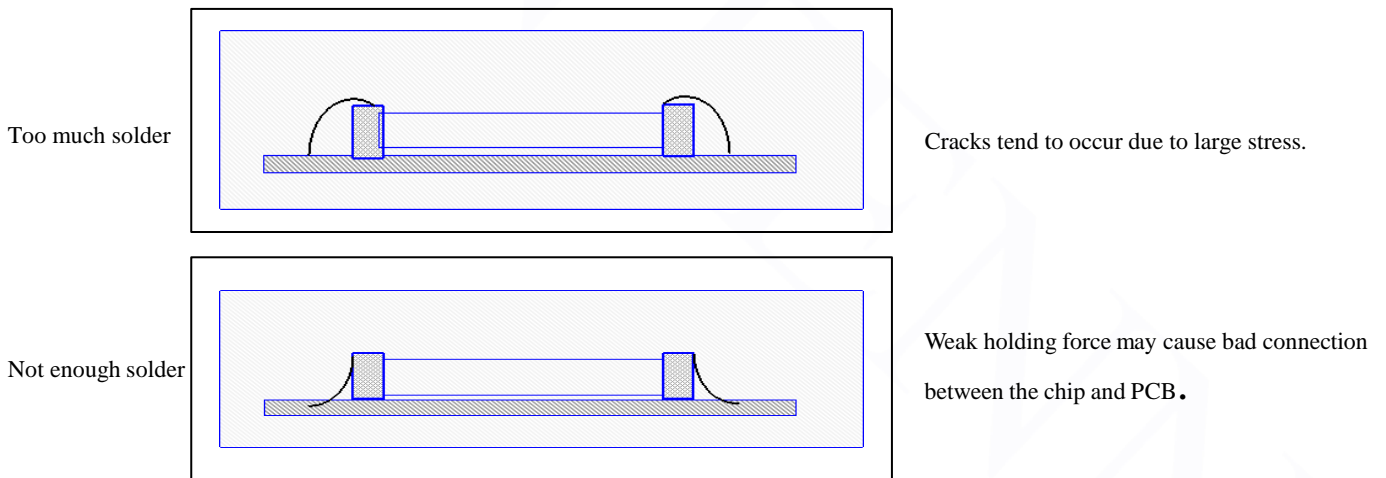

### Recommended Soldering Amounts

The optimal solder fillet amounts for re-flow soldering

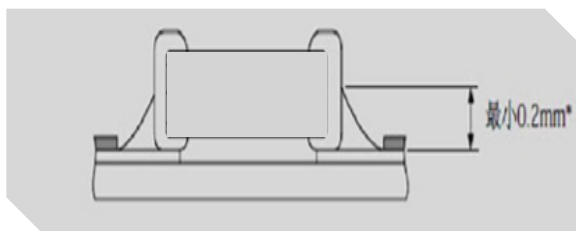

The optimal solder fillet amounts for wave soldering

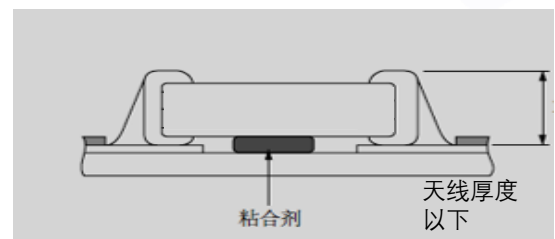



## P/N: HY160808 SRF07

### Temperature Cycle Test

10 ± 1S Applied Force: 5N Duration: 10 ± 1S  
 Preheating conditions: up-category temperature, 1h  
 Recovery time: 24 ± 1h  
 Initial Measurement  
 Cycling Times: 5 times, 1 cycle, 4 steps:

阶段	温度 (°C)	时间 (分钟)
第 1 步	下限温度(NPO/X7R/X7S/X6S/X5R-55) Y5V-25 Z5U-10	30
第 2 步	常温 (+20)	2~3
第 3 步	上限温度(NPO/X7R/X7S: +125 Y5V/Z5U/X5R-85 X6S-105)	30
第 4 步	常温 (+20)	2~3

### Resistance to Soldering Heat

Preheating 80 to 120°C; 10~30s. Solder Temperature: 235±5°C; Duration: 2±0.5s; Solder Temperature: 245±5°C  
 Duration: 2±0.5s; Preheating 100 to 200°C; 10±2min.  
 Solder Temperature: 265±5°C; Duration: 10±1s  
 Clean the capacitor with solvent and examine it with a 10X(min.) microscope.  
 Recovery Time: 24±2h  
 Recovery condition: Room temperature

### Resistance to Flexure of Substrate

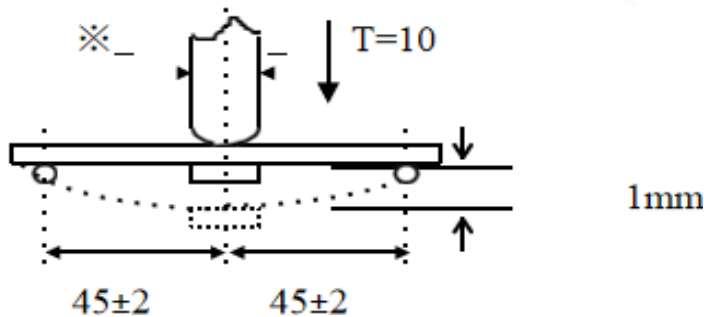

Test Board: Al<sub>2</sub>O<sub>3</sub> or PCB Warp: 1mm Speed: 0.5mm/sec.  
 Unit: mm

The measurement should be made with the board in the bending position.



**P/N: HY160808 SRF07**

**The temperature profile for soldering**

**Re-flow soldering**

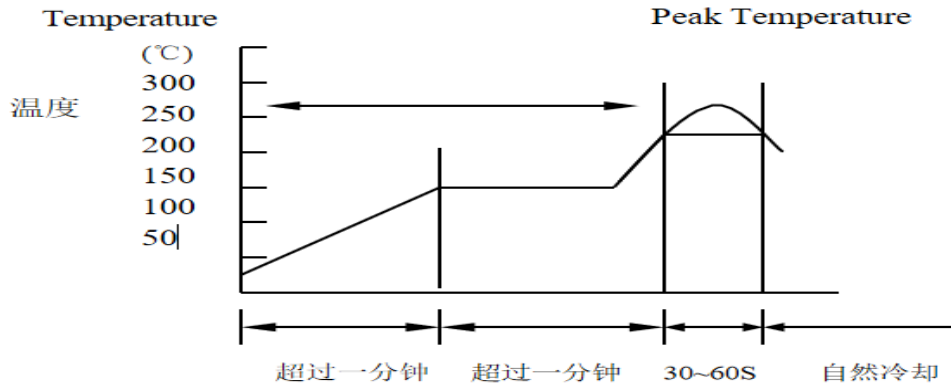

	Pb-Sn 焊接 Pb-Sn soldering	无铅焊接 Lead-free soldering
尖峰温度 Peak temperature	230°C~250°C	240°C~260°C

While in preheating, please keep the temperature difference between soldering temperature and surface temperature of chips as:  $T \leq 150^\circ\text{C}$ .

**Wave soldering**

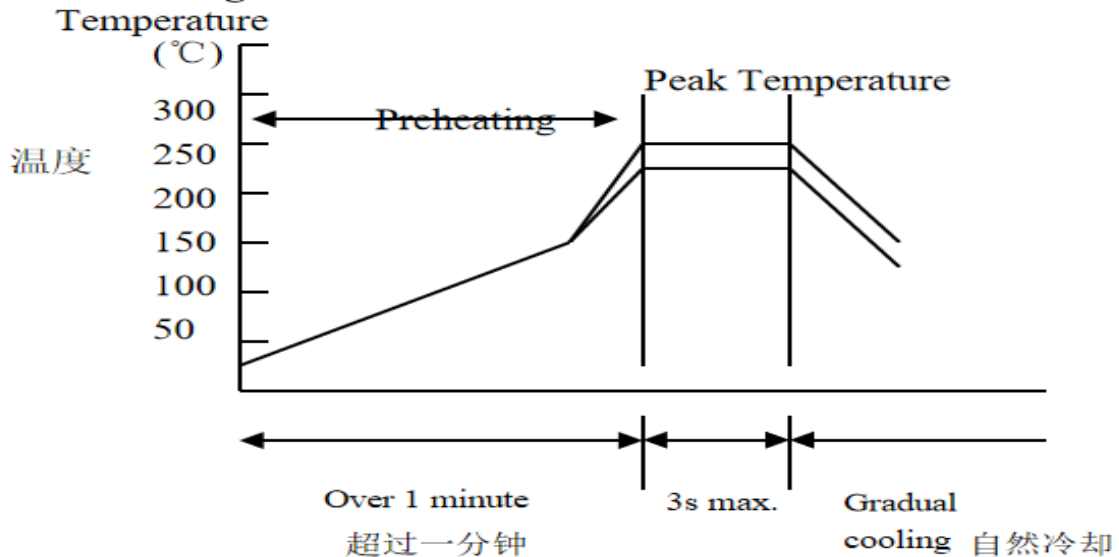

	Pb-Sn 焊接 Pb-Sn soldering	无铅焊接 Lead-free soldering
尖峰温度 Peak temperature	230°C~260°C	240°C~270°C



## P/N: HY160808 SRF07

### Dimensions of paper taping

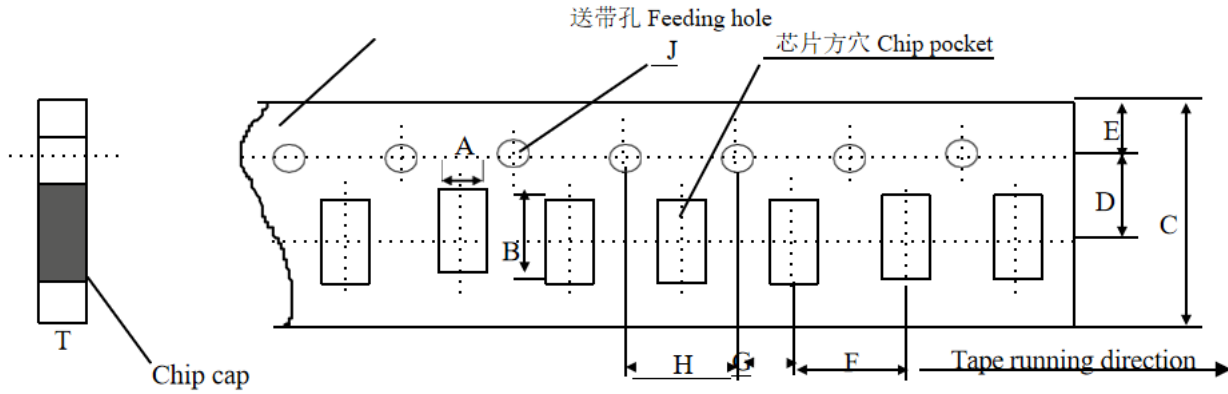

Unit: mm

代号 Code 纸带规格 papersize	A	B	C	D*	E	F	G*	H	J	T
尺寸	1.10 ±0.10	1.90 ±0.10	8.00 ±0.10	3.50 ±0.05	1.75 ±0.10	4.00 ±0.10	2.00 ±0.10	4.00 ±0.10	1.50 -0/+0.10	1.10 Max

Reel (4000 pcs/Reel)

#### EMBOSED TAPING

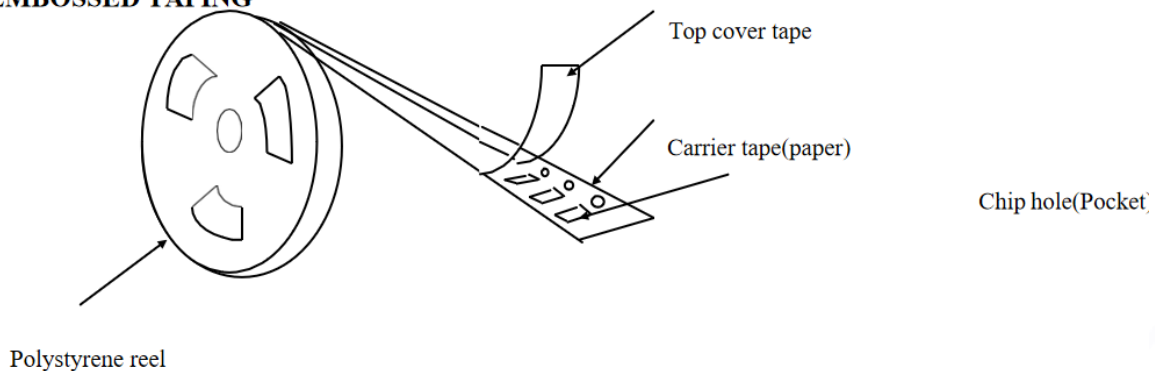

### Storage Period

The guaranteed period for solderability is 6 months (Under deliver package condition).  
Temperature: 5~40°C /Relative Humidity: 20~70%

Hanyang Antenna Design Co. Ltd. has possession of proprietary information provided in this report and this proprietary information shall be kept in strict confidence and not disclosed to any person or firm without the prior written consent of Hanyang Antenna Design Co. Ltd.