



FCC Part 15, Subpart C Test Report

FCC ID: 2AX2R-ZE8000

Applicant: final Inc.

Address: 4-44-1, Nakasaiwai-cho, Saiwai-Ku, Kawasaki-shi, Kanagawa 212-0012, Japan

Manufacturer: final Inc.

Address: 4-44-1, Nakasaiwai-cho, Saiwai-Ku, Kawasaki-shi, Kanagawa 212-0012, Japan

Product(s): ZE8000

Brand(s): final

Test Model(s): FI-ZE8DPLTW

Series Model(s): N/A

Test Date: Aug. 17, 2022~ Aug. 31, 2022

Issued Date: Sep. 06, 2022

Issued By: Hwa-Hsing (Dongguan) Testing Co., Ltd.

Address: No.101, Bld N1, Yuyuan 2Rd, Yuyuan Industrial Park, HuangJiang Town, Dongguan, China

Test Firm Registration No.: 915896

Designation No.: CN1255

Standards: 47 CFR FCC Part 15, Subpart C (Section 15.247)
ANSI C63.10:2013

The above equipment has been tested by **Hwa-Hsing (Dongguan) Testing Co., Ltd.**, and found compliance with the requirement of the above standards. The test record, data evaluation & Equipment Under Test (EUT) configurations represented herein are true and accurate accounts of the measurements of the sample's EMC characteristics under the conditions specified in this report.

Prepared by :

Niny Zhang

Niny Zhang

Reviewed by :

Scott He

Scott He

Approved by :

Tank Tan

Tank Tan

This report is for your exclusive use. Any copying or replication of this report to or for any other person or entity, or use of our name or trademark, is permitted only with our prior written permission. This report sets forth our findings solely with respect to the test samples identified herein. The results set forth in this report are not indicative or representative of the quality or characteristics of the lot from which a test sample was taken or any similar or identical product unless specifically and expressly noted. Our report includes all of the tests requested by you and the results thereof based upon the information that you provided to us. You have 60 days from date of issuance of this report to notify us of any material error or omission caused by our negligence, provided, however, that such notice shall be in writing and shall specifically address the issue you wish to raise. A failure to raise such issue within the prescribed time shall constitute your unqualified acceptance of the completeness of this report, the tests conducted and the correctness of the report contents. Unless specific mention, the uncertainty of measurement has been explicitly taken into the account to declare the compliance or non-compliance to the specification. The report must not be used by the client to claim product certification, approval, or endorsement by A2LA or any agency of the federal government. The report must not be used by the client to claim product certification, approval, or endorsement by TAF or any government agencies.



Table of Contents

Release Control Record	4
1 Summary of Test Results	5
1.1 Measurement Uncertainty.....	5
1.2 Modification Record.....	5
2 General Information	6
2.1 General Description of EUT.....	6
2.2 Description of Test Modes.....	7
2.3 Test Mode Applicability and Tested Channel Detail.....	8
2.4 Description of Support Units.....	10
2.4.1 Configuration of System under Test.....	10
3 Test Types and Results	11
3.1 Radiated Emission and Band-edge Measurement.....	11
3.1.1 Limits of Radiated Emission and Band-edge Measurement.....	11
3.1.2 Test Instruments.....	12
3.1.3 Test Procedures.....	13
3.1.4 Deviation from Test Standard.....	14
3.1.5 Test Setup.....	15
3.1.6 EUT Operating Conditions.....	16
3.1.7 Test Results.....	17
3.2 Conducted Emission Measurement.....	41
3.2.1 Limits of Conducted Emission Measurement.....	41
3.2.2 Test Instruments.....	41
3.2.3 Test Procedures.....	42
3.2.4 Test Setup.....	42
3.2.5 EUT Operating Condition.....	42
3.2.6 Deviation from Test Standard.....	42
3.2.7 Test Results.....	43
3.3 Number of Hopping Frequency Used.....	45
3.3.1 Limits of Hopping Frequency Used Measurement.....	45
3.3.2 Test Setup.....	45
3.3.3 Test Instruments.....	45
3.3.4 Test Procedure.....	45
3.3.5 Deviation from Test Standard.....	45
3.3.6 Test Results.....	46
3.4 Channel Bandwidth.....	48
3.4.1 Limits of Channel Bandwidth Measurement.....	48
3.4.2 Test Setup.....	48
3.4.3 Test Instruments.....	48
3.4.4 Test Procedure.....	48
3.4.5 Deviation from Test Standard.....	48
3.4.6 EUT Operating Condition.....	48
3.4.7 Test Results.....	49
3.5 Hopping Channel Separation.....	52
3.5.1 Limits of Hopping Channel Separation Measurement.....	52
3.5.2 Test Setup.....	52
3.5.3 Test Instruments.....	52
3.5.4 Test Procedure.....	52
3.5.5 Deviation from Test Standard.....	52
3.5.6 Test Results.....	52
3.6 Maximum Output Power.....	55
3.6.1 Limits of Maximum Output Power Measurement.....	55



3.6.2	Test Setup.....	55
3.6.3	Test Instruments	55
3.6.4	Test Procedure	55
3.6.5	Deviation fromTest Standard	56
3.6.6	EUT Operating Condition	56
3.6.7	Test Results	57
3.7	Conducted Out of Band Emission Measurement	62
3.7.1	Limits of Conducted Out of Band Emission Measurement.....	62
3.7.2	Tets Setup.....	62
3.7.3	Test Instruments	62
3.7.4	Test Procedure	63
3.7.5	Deviation from Test Standard	63
3.7.6	EUT Operating Condition	63
3.7.7	Test Results	64
4	Pictures of Test Arrangements	76
5	Test Instruments.....	77
	Appendix – Information on the Testing Laboratories	78



Release Control Record

Issue No.	Description	Date Issued
220524EL11-RF-US-02	Original Release	Sep. 06, 2022



1 Summary of Test Results

47 CFR FCC Part 15, Subpart C (Section 15.247) KDB 558074 D01 15.247 Meas Guidance v05r02 ANSI C63.10:2013;			
FCC Clause	Test Item	Result	Remarks
15.207	AC Power Conducted Emission	Pass	Meet the requirement of limit.
15.247(a)(1) (iii)	Number of Hopping Frequency Used	Pass	Meet the requirement of limit.
15.247(a)(1) (iii)	Dwell Time on Each Channel	Pass	Meet the requirement of limit.
15.247(a)(1)	1. Hopping Channel Separation 2. Spectrum Bandwidth of a Frequency Hopping Sequence Spread Spectrum System	Pass	Meet the requirement of limit.
15.247(b)	Maximum Peak Output Power	Pass	Meet the requirement of limit.
---	Occupied Bandwidth Measurement	Pass	Reference only
15.205 & 209	Radiated Emissions	Pass	Meet the requirement of limit.
15.247(d)	Band Edge Measurement	Pass	Meet the requirement of limit.
15.247(d)	Antenna Port Emission	Pass	Meet the requirement of limit.
15.203	Antenna Requirement	Pass	No antenna connector is used.

Note1: If the Frequency Hopping System operating in 2400-2483.5MHz band and the output power less than 125mW. The hopping channel carrier frequencies separated by a minimum of 25kHz or two-thirds of the 20dB bandwidth of hopping channel whichever is greater.

Note2: The EUT has been verified to comply with the requirements of FCC Part 15, Subpart B, Class B (sDoC). The test report has been issued separately.

1.1 Measurement Uncertainty

Where relevant, the following measurement uncertainty levels have been estimated for tests performed on the EUT as specified in CISPR 16-4-2:

The listed uncertainties are the worst-case uncertainty for the entire range of measurement. Please note that the uncertainty values are provided for informational purposes only and are not used in determining the PASS/FAIL results.

Measurement	Frequency	Expanded Uncertainty (k=2) (±)
Conducted Emissions at mains ports	150kHz ~ 30MHz	2.66 dB
Radiated Emissions up to 1 GHz	9KHz ~ 30MHz	2.16 dB
	30MHz ~ 1000MHz	3.47 dB
Radiated Emissions above 1 GHz	1GHz ~ 18GHz	4.84 dB
	18GHz ~ 40GHz	4.67 dB

Note: This uncertainty represents an expanded uncertainty expressed at approximately the 95% confidence level using a coverage factor of k = 2.

1.2 Modification Record

There were no modifications required for compliance.



2 General Information

2.1 General Description of EUT

Product(s)	ZE8000
Test Model(s)	FI-ZE8DPLTW
Sample No.	HS220815-01-14
Series Model(s)	N/A
Status of EUT	Engineering Prototype
Power Supply Rating	DC 3.85V from Battery
Modulation Type	GFSK, $\pi/4$ DQPSK, 8DPSK for FHSS
Transfer Rate	1Mbps, 2Mbps, 3Mbps
Operating Frequency	2402 ~ 2480MHz
Number of Channel	79
Output Power (Peak)	L: 11.226dBm R: 11.181dBm
Antenna Type	FPC Antenna
Antenna Gain	L: 0.89dBi R: 1.41dBi
Antenna Connector	N/A
Accessory Device	N/A
Cable Supplied	USB Type-C Charging Cable 37cm, Unshielded and detachable

Note:

1. Please refer to the EUT photo document (Reference No.:220524EL11-01&02) for detailed product photo.
2. The above EUT information is declared by manufacturer and for more detailed features description, please refer to the manufacturer's specifications or User's Manual.



2.2 Description of Test Modes

79 channels are provided to this EUT:

Channel	Freq. (MHz)	Channel	Freq. (MHz)	Channel	Freq. (MHz)	Channel	Freq. (MHz)
0	2402	20	2422	40	2442	60	2462
1	2403	21	2423	41	2443	61	2463
2	2404	22	2424	42	2444	62	2464
3	2405	23	2425	43	2445	63	2465
4	2406	24	2426	44	2446	64	2466
5	2407	25	2427	45	2447	65	2467
6	2408	26	2428	46	2448	66	2468
7	2409	27	2429	47	2449	67	2469
8	2410	28	2430	48	2450	68	2470
9	2411	29	2431	49	2451	69	2471
10	2412	30	2432	50	2452	70	2472
11	2413	31	2433	51	2453	71	2473
12	2414	32	2434	52	2454	72	2474
13	2415	33	2435	53	2455	73	2475
14	2416	34	2436	54	2456	74	2476
15	2417	35	2437	55	2457	75	2477
16	2418	36	2438	56	2458	76	2478
17	2419	37	2439	57	2459	77	2479
18	2420	38	2440	58	2460	78	2480
19	2421	39	2441	59	2461	-	-



2.3 Test Mode Applicability and Tested Channel Detail

EUT Configure Mode	Applicable test items	X-Axis	Y-Axis	Z-Axis	Voltage Supply
Conducted	AC Power Conducted Emission	N/A	N/A	N/A	AC120V/60Hz
Radiated	Radiated Emissions	√	√	√	power supply by battery
Antenna Port Conducted Measurement	Number of Hopping Frequency Used	N/A	N/A	N/A	
	Dwell Time on Each Channel	N/A	N/A	N/A	
	Band Edge Measurement	N/A	N/A	N/A	
	Antenna Port Emission	N/A	N/A	N/A	
	Conducted power	N/A	N/A	N/A	
	Hopping Channel Separation	N/A	N/A	N/A	
	Spectrum Bandwidth of a Frequency Hopping Sequence Spread Spectrum System	N/A	N/A	N/A	

- *: The EUT had been pre-tested on the positioned of each 3 Axis. The worst case was found when positioned on **X-plane**.
- “N/A” means no effect.

Evaluation of difference data rate:

Applicable test items	Modulation Type			The Worst-case modes recording in report
	GFSK	$\pi/4$ DQPSK	8DPSK	
Radiated Emissions	√	√	√	GFSK & 8DPSK
Antenna Port Conducted Measurement	√	√	√	GFSK & 8DPSK

Test Condition:

Applicable test items	Environmental Conditions	Test Date	Tested by
AC Power Conducted Emission	26deg. C, 52%RH	2022-8-19	King Ye
Radiated Emissions	26.5deg. C, 50%RH	2022-8-20	King Ye
Antenna Port Conducted Measurement	25.2deg. C, 61%RH	2022-8-23	Dragon Long

- Pre-Scan has been conducted to determine the worst-case mode from all possible combinations between available modulations, data rates and antenna ports (if EUT with antenna diversity architecture). Following channel(s) was (were) selected for the final test as listed below.



Radiated Emission Test (Above 1 GHz):

EUT Configure Mode	Available Channel	Tested Channel	Modulation Technology	Modulation Type	Packet Type
-	0 to 78	0, 39, 78	FHSS	GFSK	DH5
-	0 to 78	0, 39, 78	FHSS	8DPSK	3DH5

Radiated Emission Test (Below 1 GHz):

EUT Configure Mode	Available Channel	Tested Channel	Modulation Technology	Modulation Type	Packet Type
-	0 to 78	39	FHSS	GFSK	DH5
-	0 to 78	0, 39, 78	FHSS	8DPSK	3DH5

Power Line Conducted Emission Test:

EUT Configure Mode	Available Channel	Tested Channel	Modulation Technology	Modulation Type	Packet Type
-	0 to 78	39	FHSS	GFSK	DH5

Antenna Port Conducted Measurement:

This item includes all test value of each mode, but only includes spectrum plot of worst value of each mode.

EUT Configure Mode	Available Channel	Tested Channel	Modulation Technology	Modulation Type	Packet Type
-	0 to 78	0, 39, 78	FHSS	GFSK	DH5
-	0 to 78	0, 39, 78	FHSS	8DPSK	3DH5



2.4 Description of Support Units

The EUT has been tested as an independent unit together with other necessary accessories or support units. The following support units or accessories were used to form a representative test configuration during the tests.

No.	Product	Brand	Model No.	Serial No.	FCC ID
1.	Notebook	DELL	Latitude 5300	N/A	N/A

No.	Signal Cable Description of The Above Support Units
1.	USB serial cable Un-shielded 1.2m
2.	/

2.4.1 Configuration of System under Test

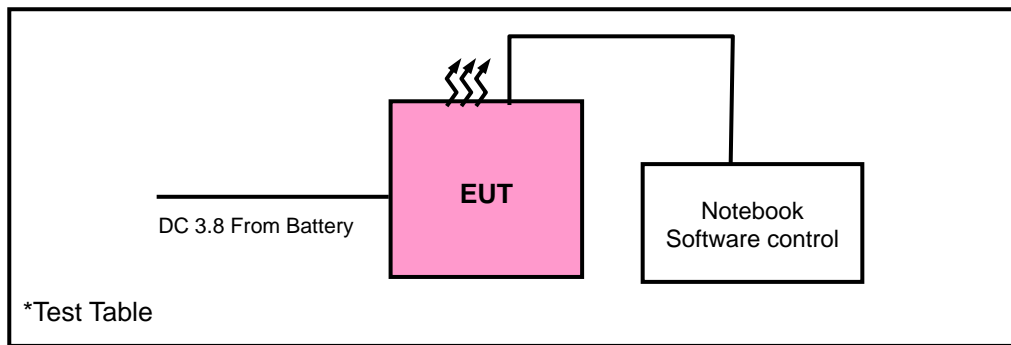



3 Test Types and Results

3.1 Radiated Emission and Band-edge Measurement

3.1.1 Limits of Radiated Emission and Band-edge Measurement

Radiated emissions which fall in the restricted bands must comply with the radiated emission limits specified as below table. Other emissions shall be at least 20 dB below the highest level of the desired power:

Frequencies (MHz)	Field Strength (microvolts/meter)	Measurement Distance (meters)
0.009 ~ 0.490	2400/F(kHz)	300
0.490 ~ 1.705	24000/F(kHz)	30
1.705 ~ 30.0	30	30
30 ~ 88	100	3
88 ~ 216	150	3
216 ~ 960	200	3
Above 960	500	3

* DTS emissions in non-restricted frequency bands Subclause 11.11 of ANSI C63.10 is applicable.

* DTS emissions in restricted frequency bands Subclause 11.12 of ANSI C63.10 is applicable

Note:

1. The lower limit shall apply at the transition frequencies.
2. Emission level (dBuV/m) = 20 log Emission level (uV/m).
3. For frequencies above 1000 MHz, the field strength limits are based on average detector, however, the peak field strength of any emission shall not exceed the maximum permitted average limits, specified above by more than 20 dB under any condition of modulation.



3.1.2 Test Instruments

Radiated emission below 30MHz:

Equipment	Manufacturer	Model No.	Serial No.	Next Cal.
EMI Test Receiver	Rohde&Schwarz	ESR7	100962	2023-01-13
3m Semi-anechoic Chamber	MAORUI	9m*6m*6m	NSEMC003	2023-04-15*
Test software	FARAD	FARAD	EZ_EMCV1.1.4.2	N/A
Loop Antenna	EMCI	HLA 6121	56735	2023-04-15*
Preamplifier	EMCI	EMC001340	980201	2022-09-08
Antenna Tower	MF	MFA-440H	NA	NA
Turn Table	MF	MFT-201SS	NA	NA
Antenna Tower&Turn Table Controller	MF	MF-7802	NA	NA

Frequency Range below 1GHz:

Equipment	Manufacturer	Model No.	Serial No.	Next Cal.
3m Semi-anechoic Chamber	MAORUI	9m*6m*6m	NSEMC003	2023-04-15*
EMI Test Receiver	Rohde&Schwarz	ESR7	100962	2023-01-13
Broadband antenna	Schwarzbeck	VULB 9168	00937	2023-09-12*
Signal Amplifier	Com-power	PAM-103	18020051	2022-09-08
Attenuator	Rohde&Schwarz	TS2GA-6dB	18101101	N/A
Test software	FARAD	FARAD	EZ_EMCV1.1.4.2	N/A

Frequency Range 1-18GHz:

Equipment	Manufacturer	Model No.	Serial No.	Next Cal.
3m Semi-anechoic Chamber	MAORUI	9m*6m*6m	NSEMC003	2023-04-15*
Horn Antenna	Schwarzbeck	BBHA 9120D	01959	2022-09-12*
Broadband Coaxial Preamplifier	Com-power	PAM-118A	1804003	2022-09-07
Spectrum	Keysight	N9020A	MY51240612	2022-09-08
Antenna Tower	MF	MFA-440H	NA	NA
Turn Table	MF	MFT-201SS	NA	NA
Antenna Tower&Turn Table Controller	MF	MF-7802	NA	NA

Frequency Range 18-40GHz:

Equipment	Manufacturer	Model No.	Serial No.	Next Cal.
3m Semi-anechoic Chamber	MAORUI	9m*6m*6m	NSEMC003	2023-04-15*
Spectrum Analyzer	Rohde&Schwarz	FSV-40N	101783	2023-01-13
Horn Antenna	Schwarzbeck	BBHA 9170	BBHA9170242	2023-04-10*
Pre-Amplifier	EMCI	EMC 184045	980102	2023-01-12
Antenna Tower	MF	MFA-440H	NA	NA
Turn Table	MF	MFT-201SS	NA	NA
Antenna Tower&Turn Table Controller	MF	MF-7802	NA	NA

Note:

1. The calibration interval of the above test instruments is 12 months or 24 months (*).
2. The test was performed in 966



3.1.3 Test Procedures

a. **Peak emission levels are measured by setting the instrument as follow:**

1) RBW&VBWsetting as a function of frequency:

Frequency	RBW	VBW
9kHz~150kHz	200Hz	600Hz
0.15MHz~30MHz	9kHz	30kHz
30MHz~1000MHz	120kHz	300kHz
>1000MHz	1MHz	3MHz

2) Detector = peak.

3) Sweep time = auto.

4) Trace mode = max hold.

5) Allow sweeps to continue until the trace stabilizes. (Note that the required measurement time may be lengthened for low-duty-cycle applications.)

Note: If the peak-detected amplitude can be shown to comply with the average limit, then it is not necessary to perform a separate average measurement

b. **Average emission levels are measured by setting the instrument as follow:**

● **Trace averaging with continuous EUT transmission at full power**

If the EUT can be configured or modified to transmit continuously (D ≥ 98%), then the average emission levels shall be measured using the following method (with EUT transmitting continuously):

- 1) RBW=1 MHz (unless otherwise specified).
- 2) VBW ≥ 3 *RBW.
- 3) Detector =RMS
- 4) Sweep time = auto.
- 5) Perform a trace average of at least 100 traces.

● **Trace averaging across ON and OFF times of the EUT transmissions followed by duty cycle correction**

If continuous transmission of the EUT (D≥98%) cannot be achieved and the duty cycle is constant (duty cycle variations are less than ±2%). then the following procedure shall be used

- 1) The EUT shall be configured to operate at the maximum achievable duty cycle.
- 2) Measure the duty cycle D of the transmitter output signal as described in 11.6.
- 3) RBW=1 MHz (unless otherwise specified).
- 4) VBW ≥ 3 *RBW.
- 5) Detector =RMS
- 6) Sweep time = auto.
- 7) Perform a trace average of at least 100 traces.

A correction factor shall be added to the measurement results prior to comparing with the emission limit to compute the emission level that would have been measured had the test been performed at 100% duty cycle. The correction factor is computed as follows:

*If power averaging (rms) mode was used in step 5). then the applicable correction factor is [10 10g (1/ D)], where D is the duty cycle.

**If linear voltage averaging mode was used in step f). then the applicable correction factor is [20 10g (1/D)], where D is the duty cycle.

***If a specific emission is demonstrated to be continuous (D > 98%) rather than turning ON and OFF with the transmit cycle, then no duty cycle correction is required for that



● **Reduced VBW Averaging across ON and OFF times of the EUT transmissions with max hold**

If continuous transmission of the EUT ($D > 98\%$) cannot be achieved and the duty cycle is not constant (duty cycle variations exceed $\pm 2\%$), then the following procedure shall be used:

- 1) RBW = 1 MHz.
 - 2) $VBW \geq 1/T$.
 - 3) Detector = peak
 - 4) Sweep time = auto.
 - 5) Trace mode = max hold.
 - 6) Allow max hold to run for at least $[50 \times (1/D)]$ traces
- c. The EUT was placed on the top of a rotating table 0.8 meters (below 1GHz) / 1.5 meters (1-18GHz) / 1.5 meters (18-40GHz) above the reference ground. The table was rotated 360 degrees to determine the position of the highest radiation.
- d. The EUT was set 3 meters away from the interference-receiving antenna (Below 1GHz) & (Above 1-18GHz), which was mounted on the top of a variable-height antenna tower. The EUT was set 1 meters away from the interference-receiving antenna (18-40GHz).
- e. The height of antenna is varied from one meter to four meters above the ground to determine the maximum value of the field strength. Both horizontal and vertical polarizations of the antenna are set to make the measurement.
- f. For each suspected emission, the EUT was arranged to its worst case and then the antenna was tuned to heights from 1 meter to 4 meters and the rotatable table was turned from 0 degrees to 360 degrees to find the maximum reading.
- g. The test-receiver system was set to quasi-peak detect function and specified bandwidth with maximum hold mode when the test frequency is below 1 GHz.

The test-receiver system was set to peak and average detected function and specified bandwidth with maximum hold mode when the test frequency is above 1 GHz. If the peak reading value also meets average limit, measurement with the average detector is unnecessary.

Note:

1. Test procedures for measuring FHSS device: The use of a duty cycle correction factor (DCCF) is permitted for calculating average radiated field strength emission levels for an FHSS device in 15.247. This DCCF can be applied when the unwanted emission limit is subject to an average field strength limit (e.g., within a Government Restricted band) and the conditions specified in Section 15.35(c) can be satisfied. The average radiated field strength is calculated by subtracting the DCCF from the maximum radiated field strength level as determined through measurement. The maximum radiated field strength level represents the worst-case (maximum amplitude) RMS measurement of the emission(s) during continuous transmission (i.e., not including any time intervals during which the transmitter is off or is transmitting at a reduced power level). It is also acceptable to apply the DCCF to a measurement performed with a peak detector instead of the specified RMS power averaging detector. Note that Section 15.35(c) specifies that the DCCF shall represent the worst-case (greatest duty cycle) over any 100 msec transmission period. Subclause 7.5 of ANSI C63.10 provides additional measurement guidance applicable to determination of the DCCF.
2. All modes of operation were investigated and the worst-case emissions are reported.

3.1.4 Deviation from Test Standard

No deviation.



3.1.5 Test Setup

Radiated emission below 30MHz:

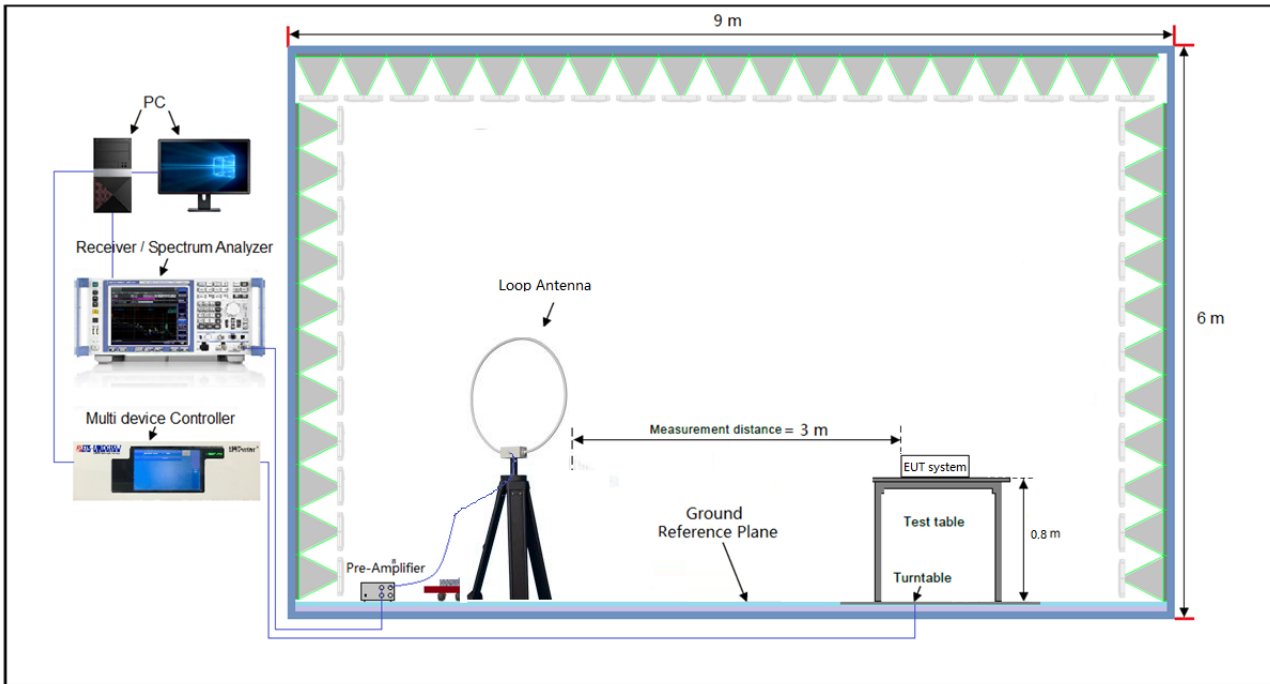

Frequency Range below 1GHz:

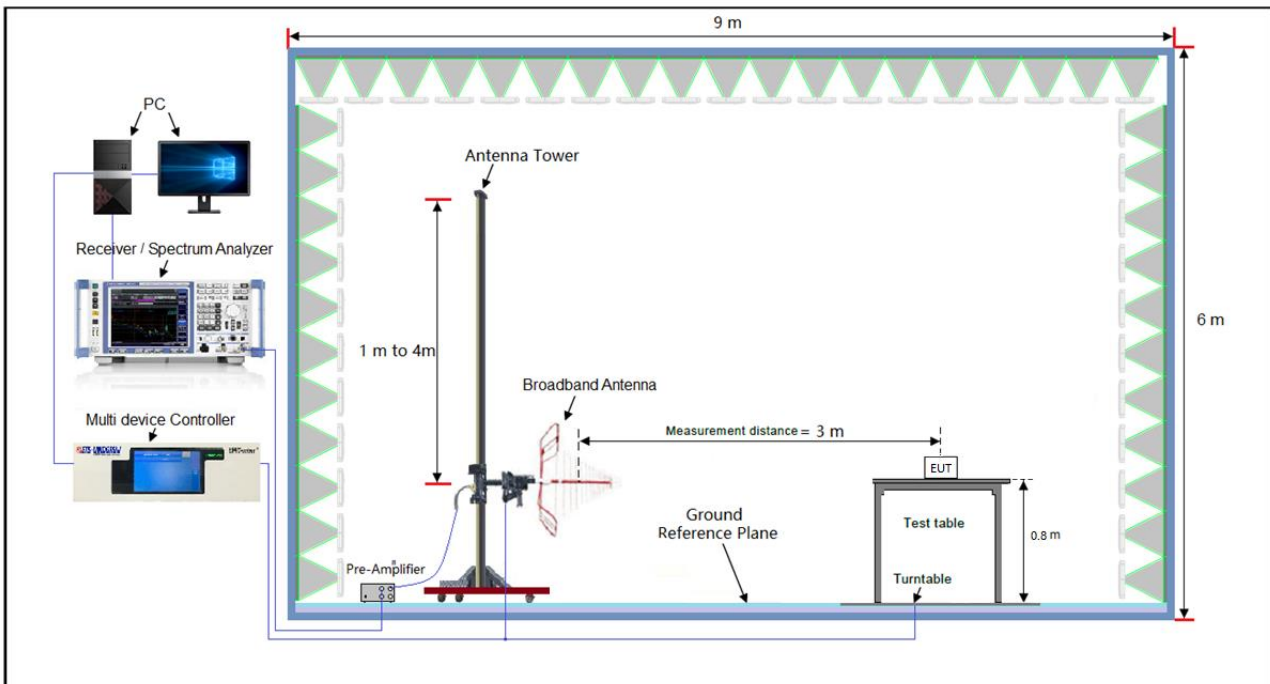



Frequency Range above 1GHz:

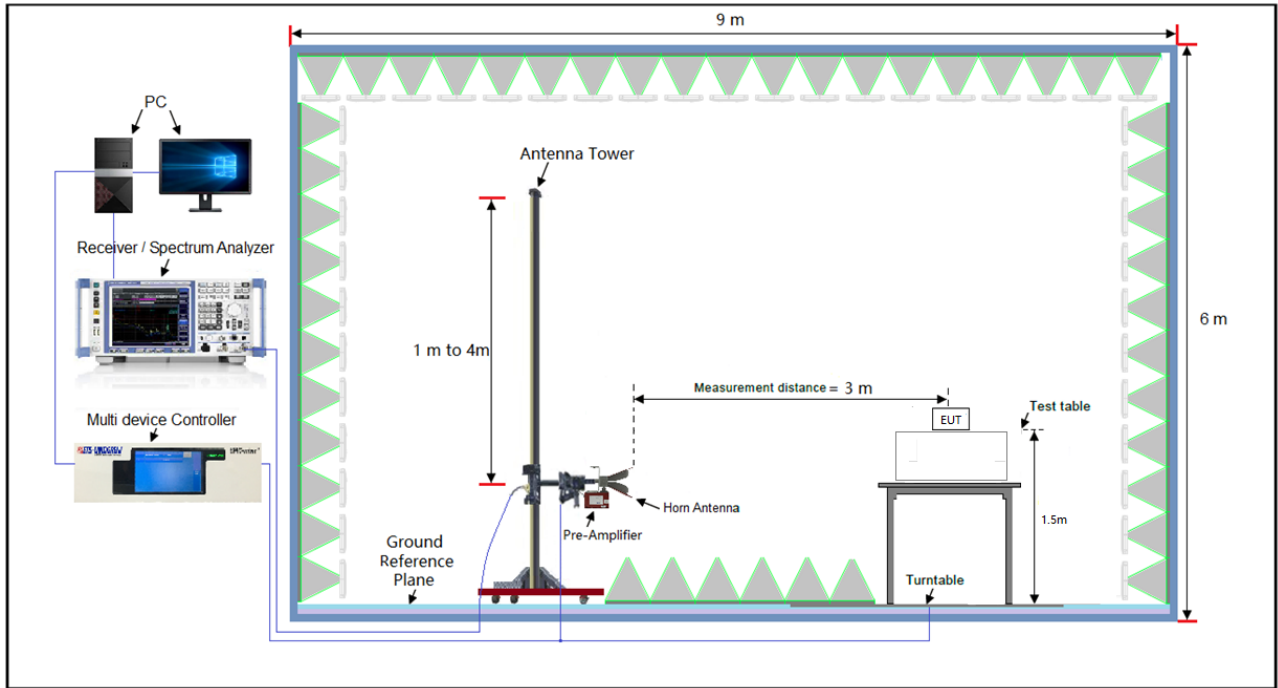

Frequency Range 18-40GHz:

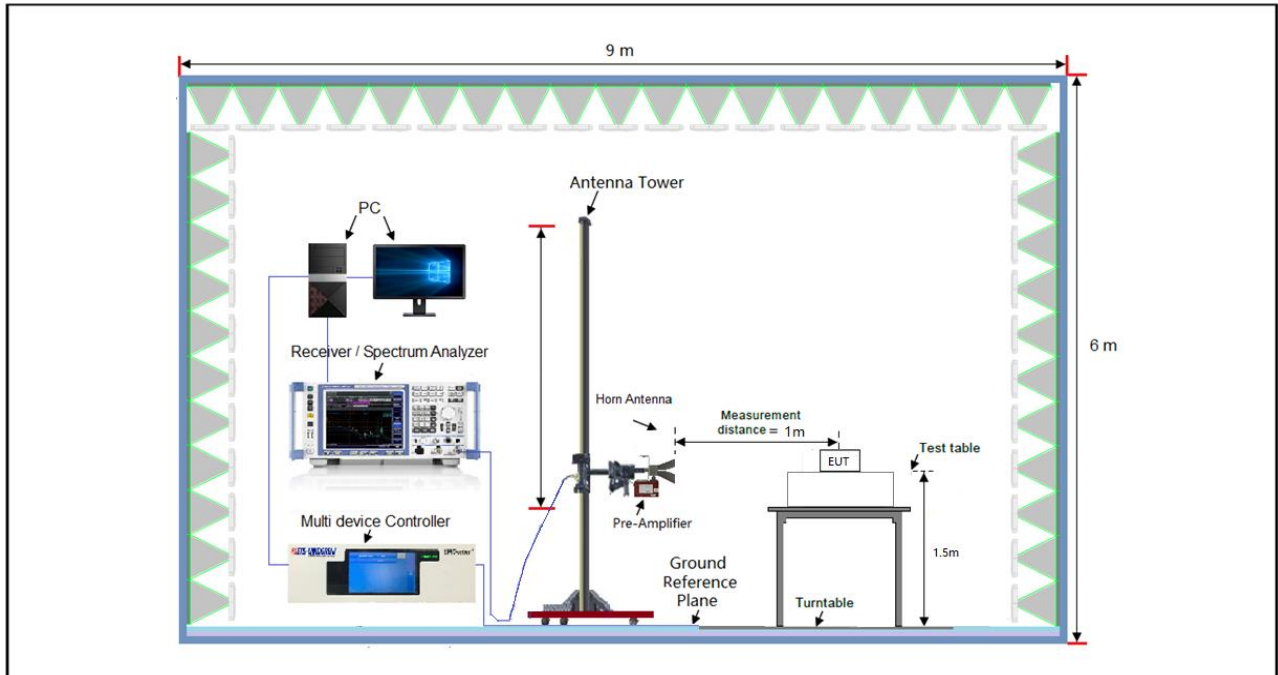

*For the actual test configuration, please refer to the attached file (Test Setup Photo).

3.1.6 EUT Operating Conditions

Set the EUT under transmission condition continuously at specific channel frequency.



3.1.7 Test Results

9 kHz ~ 30 MHz Data:

The amplitude of spurious emissions attenuated more than 20 dB below the permissible value is not required to be report.

30 MHz ~ 1GHz Worst-Case Data:

Left

Frequency Range	30MHz ~ 1GHz	Detector Function	Peak (PK) Quasi-peak (QP)
Test Channel	Channel 39		

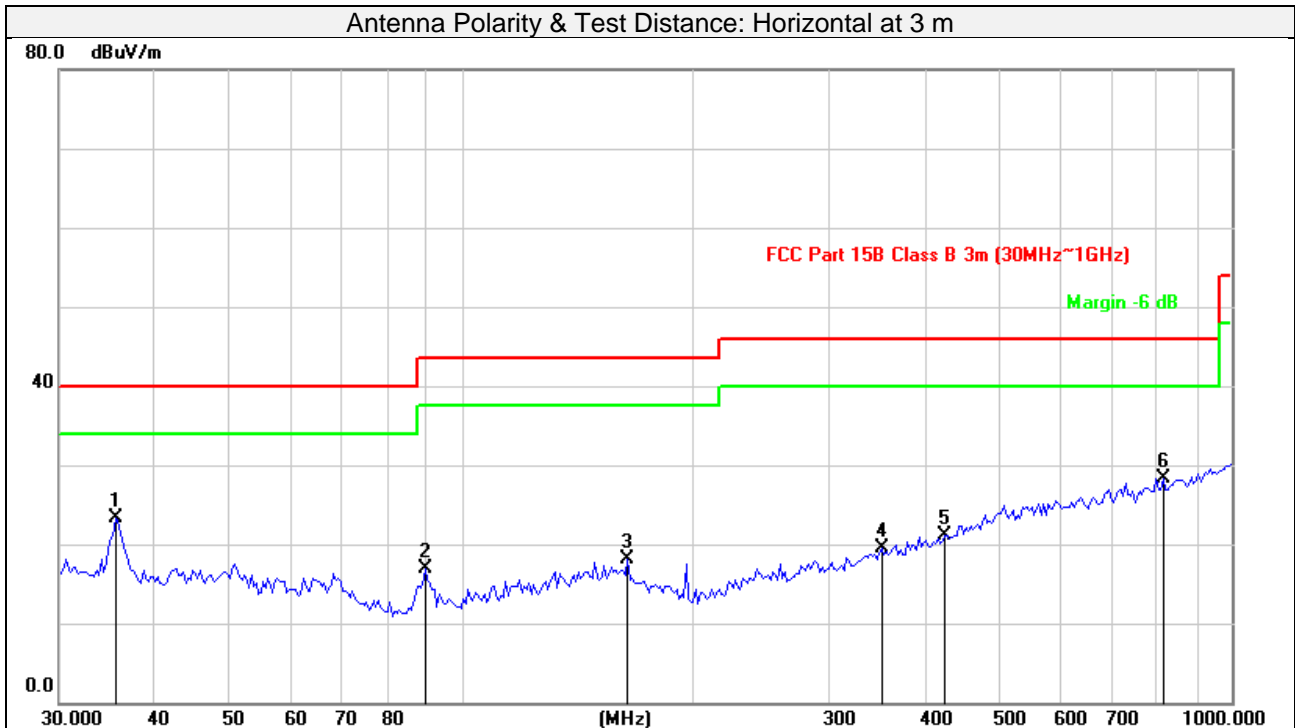

No.	Frequency (MHz)	Reading (dBuV)	Factor (dB)	Emission Level (dBuV/m)	Limit (dBuV/m)	Margin (dB)	Detector	Antenna Height (cm)	Table Angle (Degree)
1	35.5112	38.84	-15.46	23.38	40.00	-16.62	peak	200	165
2	89.7866	36.23	-19.40	16.83	43.50	-26.67	peak	100	154
3	164.3129	32.62	-14.46	18.16	43.50	-25.34	peak	200	79
4	350.9722	30.94	-11.49	19.45	46.00	-26.55	peak	300	125
5	424.2999	30.20	-9.14	21.06	46.00	-24.94	peak	200	255
6	815.6352	30.31	-1.92	28.39	46.00	-17.61	peak	100	136

Remarks:

- 1.Emission Level = Read Level + Factor (Antenna Factor + Cable Loss - Preamp Factor)
- 2.Margin value = Emission level – Limit value



Frequency Range	30MHz ~ 1GHz	Detector Function	Peak (PK) Quasi-peak (QP)
Test Channel	Channel 39		

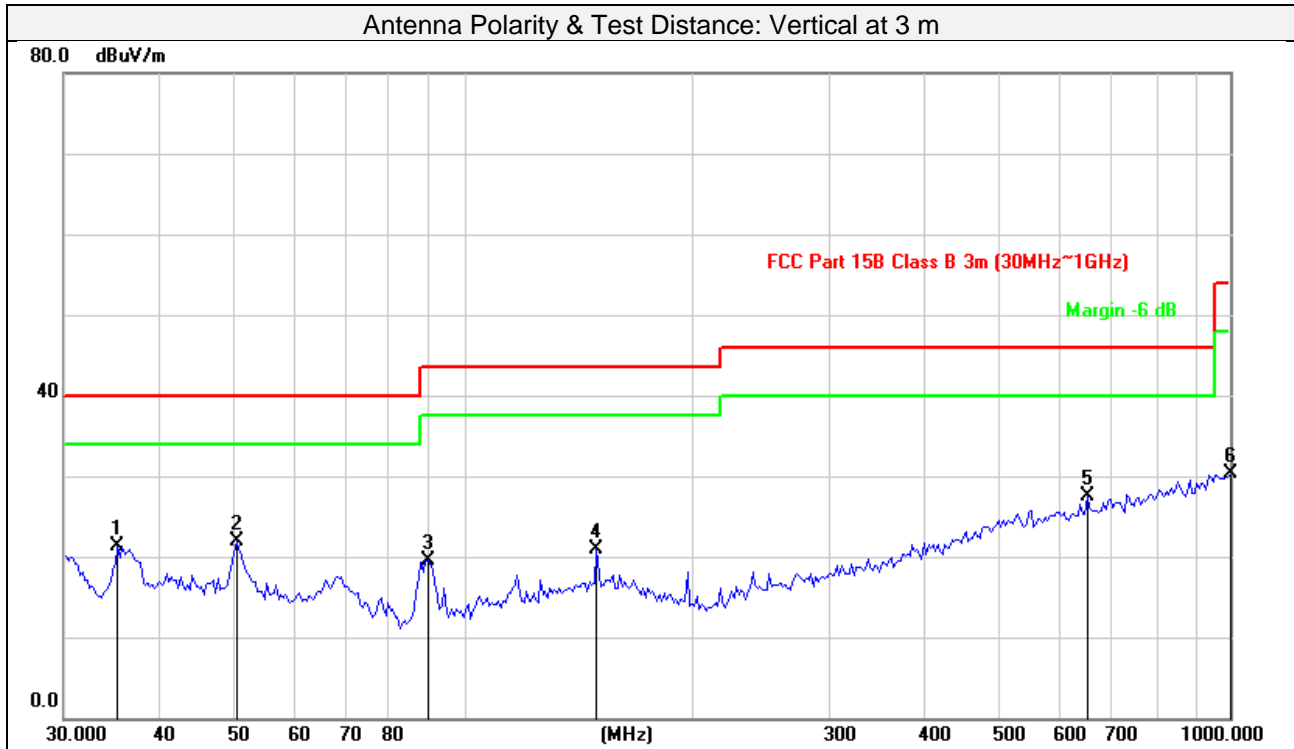

No.	Frequency (MHz)	Reading (dBuV)	Factor (dB)	Emission Level (dBuV/m)	Limit (dBuV/m)	Margin (dB)	Detector	Antenna Height (cm)	Table Angle (Degree)
1	35.2626	36.77	-15.49	21.28	40.00	-18.72	peak	100	105
2	50.4614	37.10	-15.14	21.96	40.00	-18.04	peak	200	249
3	89.7866	38.99	-19.40	19.59	43.50	-23.91	peak	300	48
4	148.9175	35.45	-14.48	20.97	43.50	-22.53	peak	200	255
5	651.3831	31.86	-4.38	27.48	46.00	-18.52	peak	100	136
6	1000.0000	29.08	1.23	30.31	54.00	-23.69	peak	200	125

Remarks:

1. Emission Level = Read Level + Factor (Antenna Factor + Cable Loss - Preamp Factor)
2. Margin value = Emission level – Limit value



Right

Frequency Range	30MHz ~ 1GHz	Detector Function	Peak (PK) Quasi-peak (QP)
Test Channel	Channel 39		

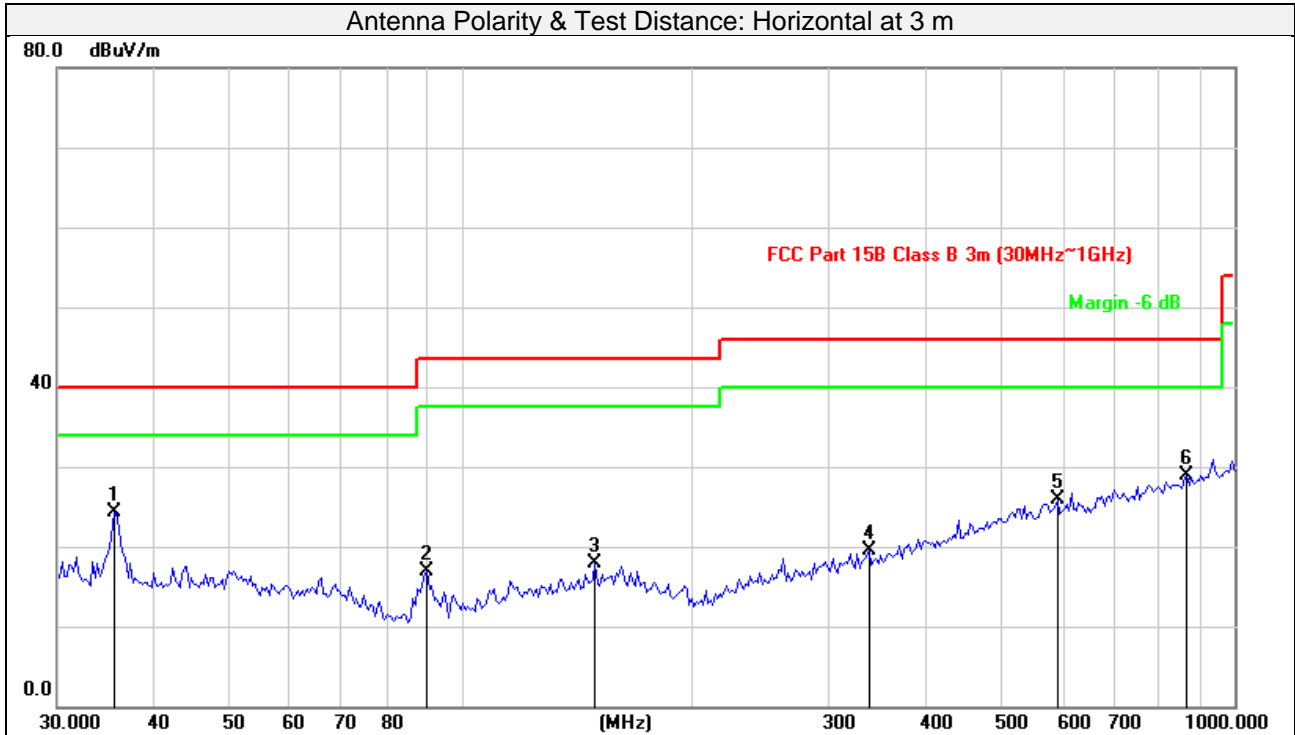

No.	Frequency (MHz)	Reading (dBUV)	Factor (dB)	Emission Level (dBUV/m)	Limit (dBUV/m)	Margin (dB)	Detector	Antenna Height (cm)	Table Angle (Degree)
1	35.5112	39.76	-15.46	24.30	40.00	-15.70	peak	100	310
2	90.4198	36.19	-19.36	16.83	43.50	-26.67	peak	200	54
3	148.9175	32.41	-14.48	17.93	43.50	-25.57	peak	300	49
4	336.4817	31.40	-11.92	19.48	46.00	-26.52	peak	200	177
5	590.3511	31.10	-5.23	25.87	46.00	-20.13	peak	200	255
6	868.8860	30.10	-1.21	28.89	46.00	-17.11	peak	100	236

Remarks:

- 1.Emission Level = Read Level + Factor (Antenna Factor + Cable Loss - Preamp Factor)
- 2.Margin value = Emission level – Limit value



Frequency Range	30MHz ~ 1GHz	Detector Function	Peak (PK) Quasi-peak (QP)
Test Channel	Channel 39		

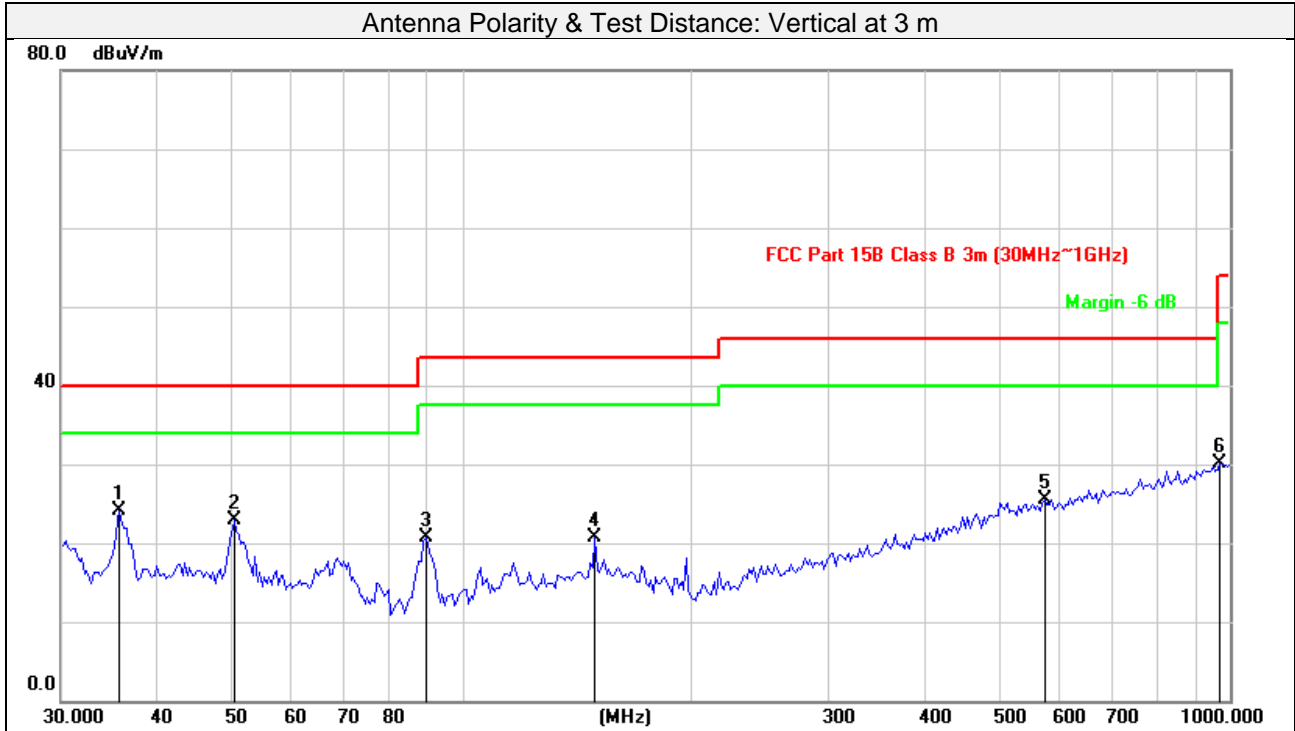

No.	Frequency (MHz)	Reading (dBuV)	Factor (dB)	Emission Level (dBuV/m)	Limit (dBuV/m)	Margin (dB)	Detector	Antenna Height (cm)	Table Angle (Degree)
1	35.7617	39.48	-15.43	24.05	40.00	-15.95	peak	100	199
2	50.4614	37.95	-15.14	22.81	40.00	-17.19	peak	200	257
3	89.7866	40.11	-19.40	20.71	43.50	-22.79	peak	200	189
4	148.9175	35.16	-14.48	20.68	43.50	-22.82	peak	300	57
5	573.9882	31.03	-5.47	25.56	46.00	-20.44	peak	100	66
6	972.2827	29.37	0.66	30.03	54.00	-23.97	peak	200	236

Remarks:

1. Emission Level = Read Level + Factor (Antenna Factor + Cable Loss - Preamp Factor)
2. Margin value = Emission level – Limit value



Left

Above 1GHz Data:

GFSK

Frequency Range	1GHz ~ 25GHz	Detector Function	Peak (PK) Average (AVG)
Test Channel	Channel 0		

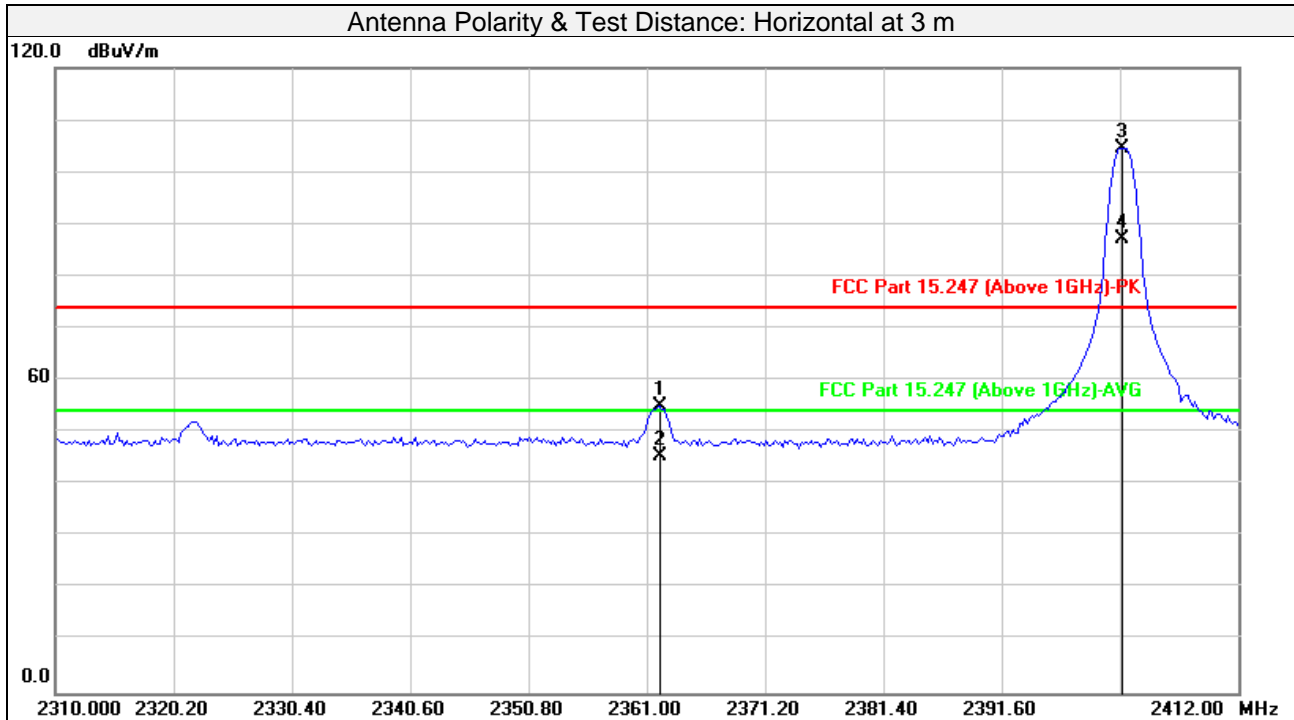

No.	Frequency (MHz)	Reading (dBuV)	Factor (dB)	Emission Level (dBuV/m)	Limit (dBuV/m)	Margin (dB)	Detector	Antenna Height (cm)	Table Angle (Degree)
1	2362.124	54.13	0.79	54.92	74.00	-19.08	peak	100	310
2	2362.124	44.75	0.79	45.54	54.00	-8.46	AVG	100	310
3#	2401.984	103.88	0.75	104.63			peak	100	310
4#	2401.984	86.39	0.75	87.14			AVG	100	310
5	4804.000	42.99	7.27	50.26	74.00	-23.74	peak	116	322
6	4804.000	35.97	7.27	43.24	54.00	-10.76	AVG	116	322
7	7206.000	38.44	10.75	49.19	74.00	-24.81	peak	100	233
8	7206.000	27.79	10.75	38.54	54.00	-15.46	AVG	100	233

Remarks:

- Emission Level = Read Level + Factor (Antenna Factor + Cable Loss - Preamp Factor)
Margin value = Emission level – Limit value
- #2402MHz: Fundamental frequency.
- The amplitude of spurious emissions attenuated more than 20 dB below the permissible value is not required to be report.



Frequency Range	1GHz ~ 25GHz	Detector Function	Peak (PK) Average (AVG)
Test Channel	Channel 0		

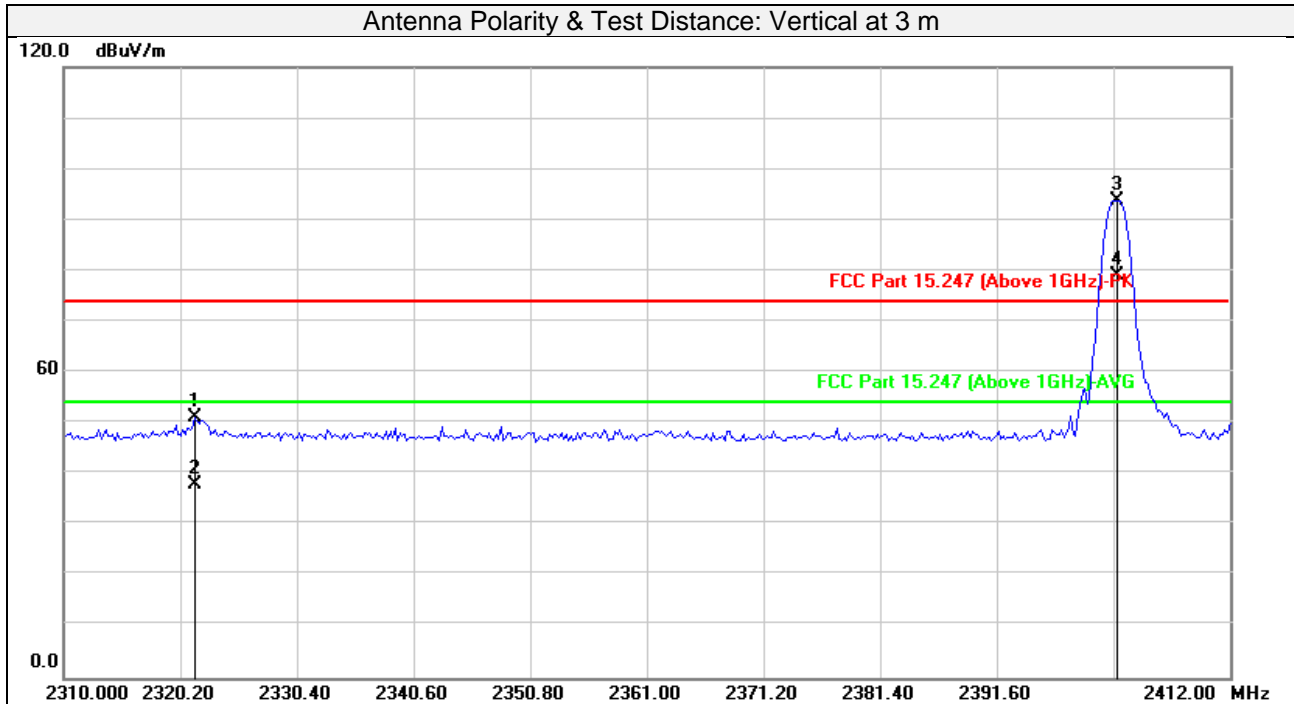

No.	Frequency (MHz)	Reading (dBuV)	Factor (dB)	Emission Level (dBuV/m)	Limit (dBuV/m)	Margin (dB)	Detector	Antenna Height (cm)	Table Angle (Degree)
1	2321.447	50.18	0.85	51.03	74.00	-22.97	peak	100	252
2	2321.447	37.13	0.85	37.98	54.00	-16.02	AVG	100	252
3#	2402.188	93.07	0.74	93.81			peak	100	252
4#	2402.188	78.29	0.74	79.03			AVG	100	252
5	4804.000	42.33	7.27	49.60	74.00	-24.40	peak	116	169
6	4804.000	35.10	7.27	42.37	54.00	-11.63	AVG	116	169
7	7206.000	35.23	10.75	45.98	74.00	-28.02	peak	100	135
8	7206.000	23.37	10.75	34.12	54.00	-19.88	AVG	100	135

Remarks:

- Emission Level = Read Level + Factor (Antenna Factor + Cable Loss - Preamp Factor)
Margin value = Emission level – Limit value
- #2402MHz: Fundamental frequency.
- The amplitude of spurious emissions attenuated more than 20 dB below the permissible value is not required to be report.



Frequency Range	1GHz ~ 25GHz	Detector Function	Peak (PK) Average (AVG)
Test Channel	Channel 39		

Antenna Polarity & Test Distance: Horizontal at 3 m									
No.	Frequency (MHz)	Reading (dBuV)	Factor (dB)	Emission Level (dBuV/m)	Limit (dBuV/m)	Margin (dB)	Detector	Antenna Height (cm)	Table Angle (Degree)
1 #	2441.000	103.93	0.69	104.62			peak	100	87
2 #	2441.000	86.87	0.69	87.56			AVG	100	87
3	4882.000	42.76	7.61	50.37	74.00	-23.63	peak	100	155
4	4882.000	35.20	7.61	42.81	54.00	-11.19	AVG	100	155
5	7323.000	38.19	10.92	49.11	74.00	-24.89	peak	100	241
6	7323.000	28.35	10.92	39.27	54.00	-14.73	AVG	100	241
Antenna Polarity & Test Distance: Vertical at 3 m									
No.	Frequency (MHz)	Reading (dBuV)	Factor (dB)	Emission Level (dBuV/m)	Limit (dBuV/m)	Margin (dB)	Detector	Antenna Height (cm)	Table Angle (Degree)
1 #	2441.000	93.37	0.69	94.06			peak	100	298
2 #	2441.000	78.42	0.69	79.11			AVG	100	298
3	4882.000	42.21	7.61	49.82	74.00	-24.18	peak	100	113
4	4882.000	34.83	7.61	42.44	54.00	-11.56	AVG	100	113
5	7323.000	35.25	10.92	46.17	74.00	-27.83	peak	100	207
6	7323.000	25.23	10.92	36.15	54.00	-17.85	AVG	100	207

Remarks:

- Emission Level = Read Level + Factor (Antenna Factor + Cable Loss - Preamp Factor)
Margin value = Emission level – Limit value
- #2441MHz: Fundamental frequency.
- The amplitude of spurious emissions attenuated more than 20 dB below the permissible value is not required to be report.



Frequency Range	1GHz ~ 25GHz	Detector Function	Peak (PK) Average (AVG)
Test Channel	Channel 78		

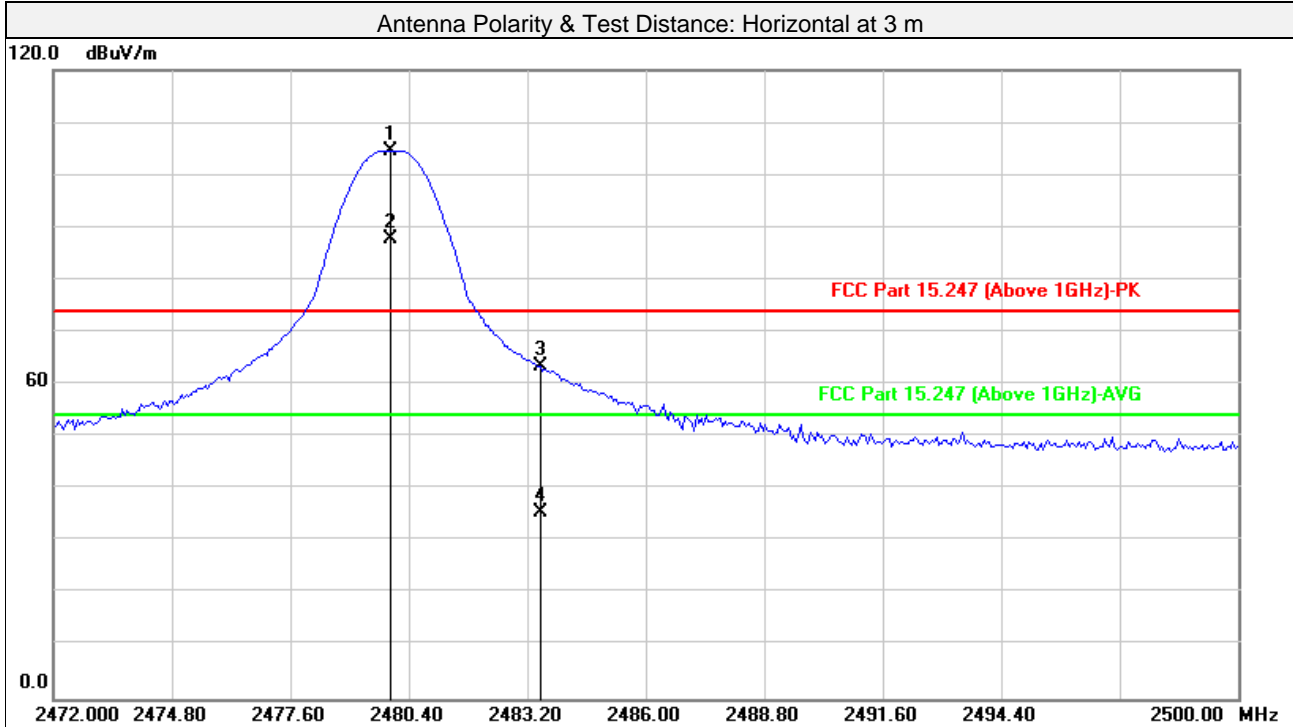

No.	Frequency (MHz)	Reading (dBuV)	Factor (dB)	Emission Level (dBuV/m)	Limit (dBuV/m)	Margin (dB)	Detector	Antenna Height (cm)	Table Angle (Degree)
1#	2479.968	103.99	0.64	104.63			peak	100	240
2#	2479.968	87.18	0.64	87.82			AVG	100	240
3	2483.500	62.69	0.63	63.32	74.00	-10.68	peak	100	240
4	2483.500	34.95	0.63	35.58	54.00	-18.42	AVG	100	240
5	4960.000	42.48	7.94	50.42	74.00	-23.58	peak	100	324
6	4960.000	34.48	7.94	42.42	54.00	-11.58	AVG	100	324
7	7440.000	37.95	11.09	49.04	74.00	-24.96	peak	100	240
8	7440.000	29.72	11.09	40.81	54.00	-13.19	AVG	100	240

Remarks:

- Emission Level = Read Level + Factor (Antenna Factor + Cable Loss - Preamp Factor)
Margin value = Emission level – Limit value
- #2480MHz: Fundamental frequency.
- The amplitude of spurious emissions attenuated more than 20 dB below the permissible value is not required to be report.



Frequency Range	1GHz ~ 25GHz	Detector Function	Peak (PK) Average (AVG)
Test Channel	Channel 78		

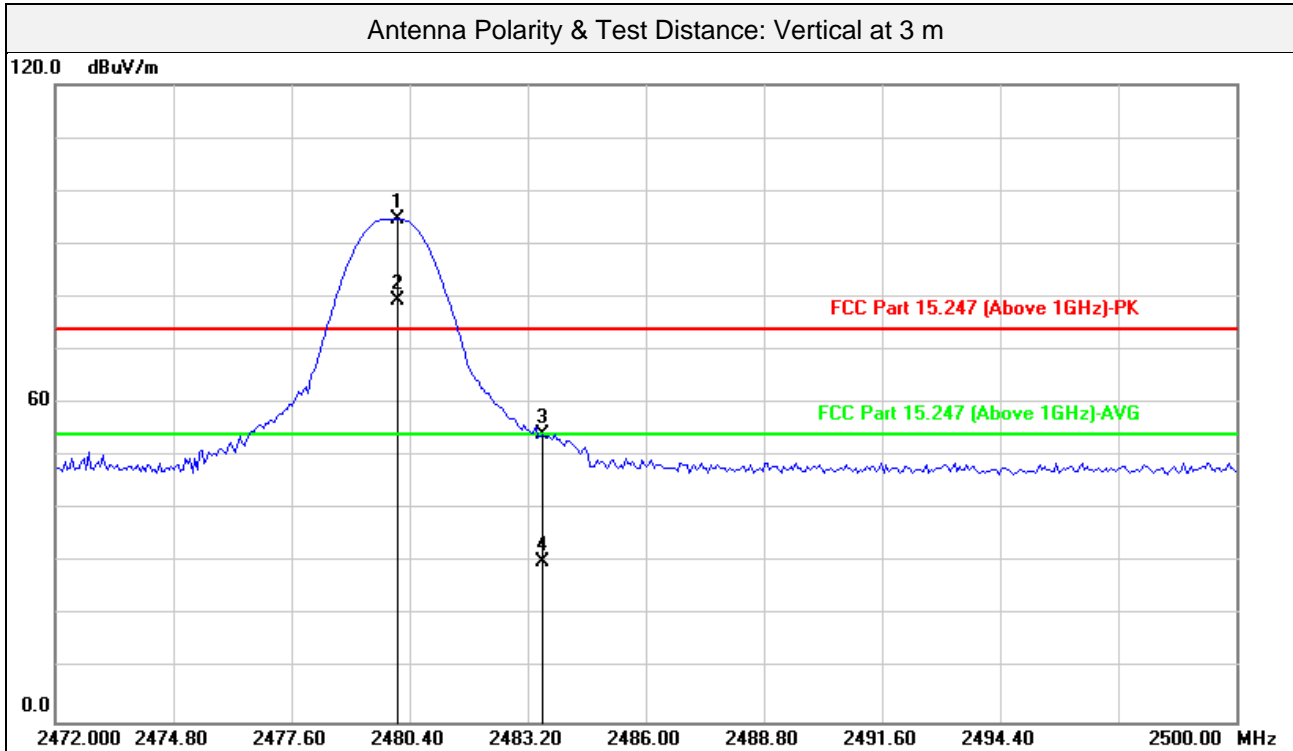

No.	Frequency (MHz)	Reading (dBuV)	Factor (dB)	Emission Level (dBuV/m)	Limit (dBuV/m)	Margin (dB)	Detector	Antenna Height (cm)	Table Angle (Degree)
1#	2480.136	94.00	0.64	94.64	74.00	20.64	peak	100	10
2#	2480.136	78.63	0.64	79.27	54.00	25.27	AVG	100	10
3	2483.559	53.47	0.63	54.10	74.00	-19.90	peak	100	10
4	2483.559	29.39	0.63	30.02	54.00	-23.98	AVG	100	10
5	4960.000	42.06	7.94	50.00	74.00	-24.00	peak	100	154
6	4960.000	34.68	7.94	42.62	54.00	-11.38	AVG	100	154
7	7440.000	36.17	11.09	47.26	74.00	-26.74	peak	100	195
8	7440.000	26.89	11.09	37.98	54.00	-16.02	AVG	100	195

Remarks:

- Emission Level = Read Level + Factor (Antenna Factor + Cable Loss - Preamp Factor)
Margin value = Emission level – Limit value
- #2480MHz: Fundamental frequency.
- The amplitude of spurious emissions attenuated more than 20 dB below the permissible value is not required to be report.



8DPSK

Frequency Range	1GHz ~ 25GHz	Detector Function	Peak (PK) Average (AVG)
Test Channel	Channel 0		

Antenna Polarity & Test Distance: Horizontal at 3 m

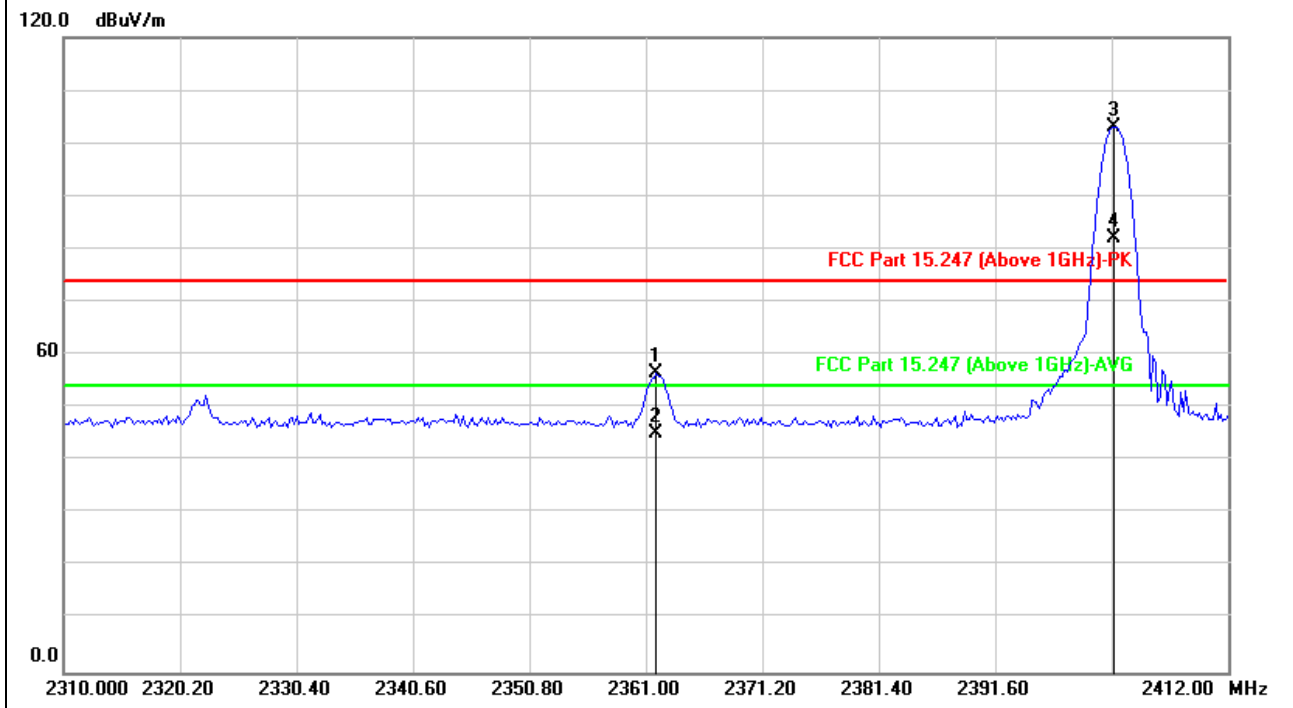

No.	Frequency (MHz)	Reading (dBuV)	Factor (dB)	Emission Level (dBuV/m)	Limit (dBuV/m)	Margin (dB)	Detector	Antenna Height (cm)	Table Angle (Degree)
1	2361.920	55.63	0.80	56.43	74.00	-17.57	peak	100	241
2	2361.920	44.32	0.80	45.12	54.00	-8.88	AVG	100	241
3#	2401.984	102.44	0.75	103.19			peak	100	241
4#	2401.984	81.45	0.75	82.20			AVG	100	241
5	4804.000	41.92	7.27	49.19	74.00	-24.81	peak	100	110
6	4804.000	32.19	7.27	39.46	54.00	-14.54	AVG	100	110
7	7206.000	35.74	10.75	46.49	74.00	-27.51	peak	100	222
8	7206.000	21.90	10.75	32.65	54.00	-21.35	AVG	100	222

Remarks:

- Emission Level = Read Level + Factor (Antenna Factor + Cable Loss - Preamp Factor)
Margin value = Emission level – Limit value
- #2402MHz: Fundamental frequency.
- The amplitude of spurious emissions attenuated more than 20 dB below the permissible value is not required to be report.



Frequency Range	1GHz ~ 25GHz	Detector Function	Peak (PK) Average (AVG)
Test Channel	Channel 0		

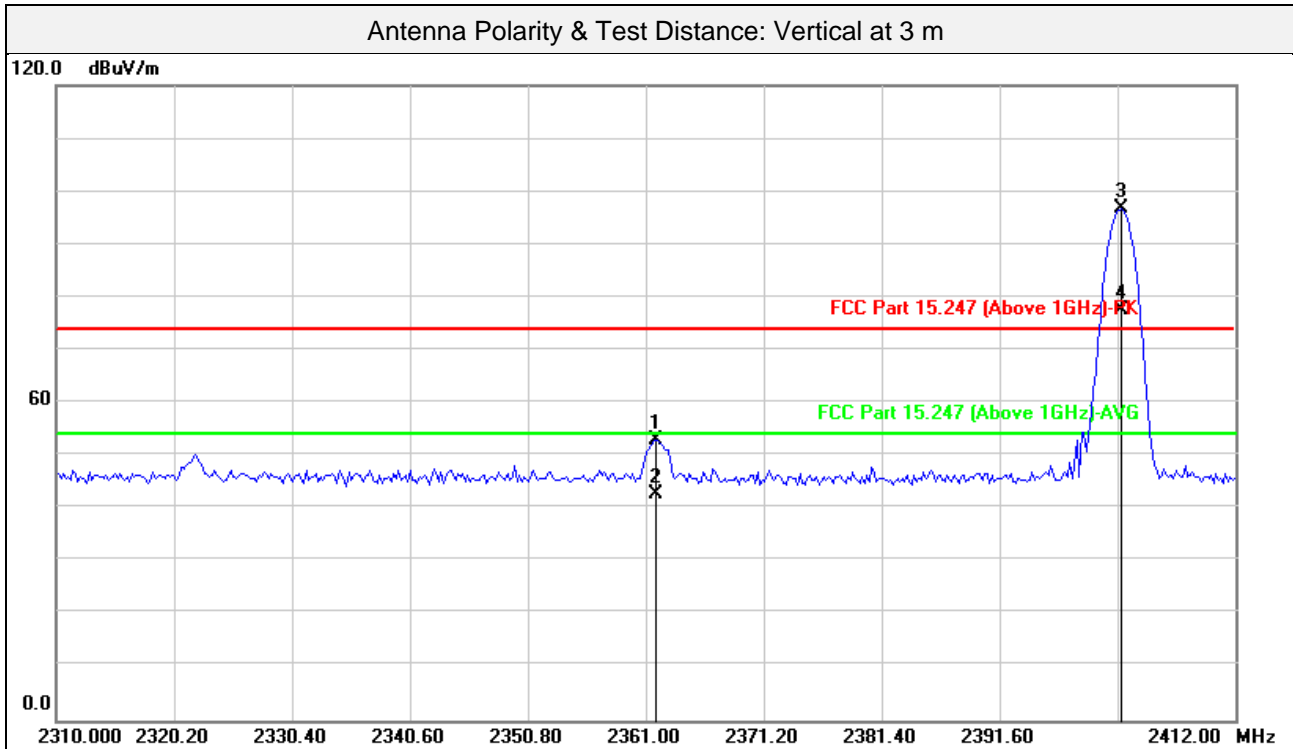

No.	Frequency (MHz)	Reading (dBuV)	Factor (dB/m)	Emission Level (dBuV/m)	Limit (dBuV/m)	Margin (dB)	Detector	Antenna Height (cm)	Table Angle (Degree)
1	2361.920	52.21	0.80	53.01	74.00	-20.99	peak	100	353
2	2361.920	41.86	0.80	42.66	54.00	-11.34	AVG	100	353
3#	2402.188	95.90	0.74	96.64			peak	100	353
4#	2402.188	76.94	0.74	77.68			AVG	100	353
5	4804.000	43.04	7.27	50.31	74.00	-23.69	peak	100	172
6	4804.000	32.20	7.27	39.47	54.00	-14.53	AVG	100	172
7	7206.000	33.97	10.75	44.72	74.00	-29.28	peak	100	205
8	7206.000	23.00	10.75	33.75	54.00	-20.25	AVG	100	205

Remarks:

- Emission Level = Read Level + Factor (Antenna Factor + Cable Loss - Preamp Factor)
Margin value = Emission level – Limit value
- #2402MHz: Fundamental frequency.
- The amplitude of spurious emissions attenuated more than 20 dB below the permissible value is not required to be report.



Frequency Range	1GHz ~ 25GHz	Detector Function	Peak (PK) Average (AVG)
Test Channel	Channel 39		

Antenna Polarity & Test Distance: Horizontal at 3 m									
No.	Frequency (MHz)	Reading (dBuV)	Factor (dB)	Emission Level (dBuV/m)	Limit (dBuV/m)	Margin (dB)	Detector	Antenna Height (cm)	Table Angle (Degree)
1#	2441.000	103.97	0.69	104.66			peak	100	45
2#	2441.000	83.68	0.69	84.37			AVG	100	45
3	4882.000	41.56	7.61	49.17	74.00	-24.83	peak	100	281
4	4882.000	31.94	7.61	39.55	54.00	-14.45	AVG	100	281
5	7323.000	35.58	10.92	46.50	74.00	-27.50	peak	100	166
6	7323.000	22.89	10.92	33.81	54.00	-20.19	AVG	100	166
Antenna Polarity & Test Distance: Vertical at 3 m									
No.	Frequency (MHz)	Reading (dBuV)	Factor (dB)	Emission Level (dBuV/m)	Limit (dBuV/m)	Margin (dB)	Detector	Antenna Height (cm)	Table Angle (Degree)
1#	2441.000	97.12	0.69	97.81			peak	100	202
2#	2441.000	77.55	0.69	78.24			AVG	100	202
3	4882.000	42.10	7.61	49.71	74.00	-24.29	peak	100	188
4	4882.000	31.82	7.61	39.43	54.00	-14.57	AVG	100	188
5	7323.000	34.15	10.92	45.07	74.00	-28.93	peak	100	266
6	7323.000	22.66	10.92	33.58	54.00	-20.42	AVG	100	266

Remarks:

- Emission Level = Read Level + Factor (Antenna Factor + Cable Loss - Preamp Factor)
Margin value = Emission level – Limit value
- #2441MHz: Fundamental frequency.
- The amplitude of spurious emissions attenuated more than 20 dB below the permissible value is not required to be report.



Frequency Range	1GHz ~ 25GHz	Detector Function	Peak (PK) Average (AVG)
Test Channel	Channel 78		

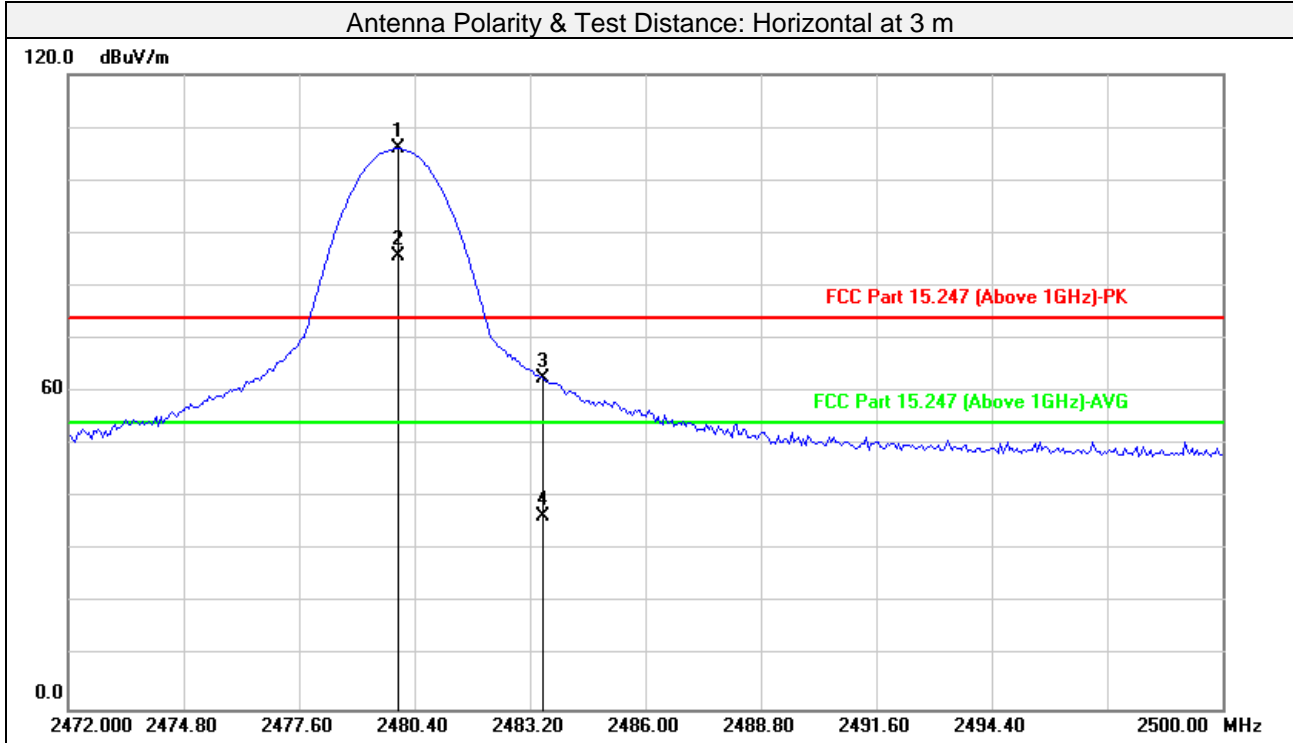

No.	Frequency (MHz)	Reading (dBuV)	Factor (dB/m)	Emission Level (dBuV/m)	Limit (dBuV/m)	Margin (dB)	Detector	Antenna Height (cm)	Table Angle (Degree)
1#	2480.024	105.35	0.64	105.99	74.00	31.99	peak	100	100
2#	2480.024	84.98	0.64	85.62	54.00	31.62	AVG	100	100
3	2483.500	61.97	0.63	62.60	74.00	-11.40	peak	100	100
4	2483.500	35.84	0.63	36.47	54.00	-17.53	AVG	100	100
5	4960.000	41.21	7.94	49.15	74.00	-24.85	peak	100	212
6	4960.000	31.93	7.94	39.87	54.00	-14.13	AVG	100	212
7	7440.000	35.44	11.09	46.53	74.00	-27.47	peak	100	163
8	7440.000	23.71	11.09	34.80	54.00	-19.20	AVG	100	163

Remarks:

- Emission Level = Read Level + Factor (Antenna Factor + Cable Loss - Preamp Factor)
Margin value = Emission level – Limit value
- #2480MHz: Fundamental frequency.
- The amplitude of spurious emissions attenuated more than 20 dB below the permissible value is not required to be report.



Frequency Range	1GHz ~ 25GHz	Detector Function	Peak (PK) Average (AVG)
Test Channel	Channel 78		

Antenna Polarity & Test Distance: Vertical at 3 m

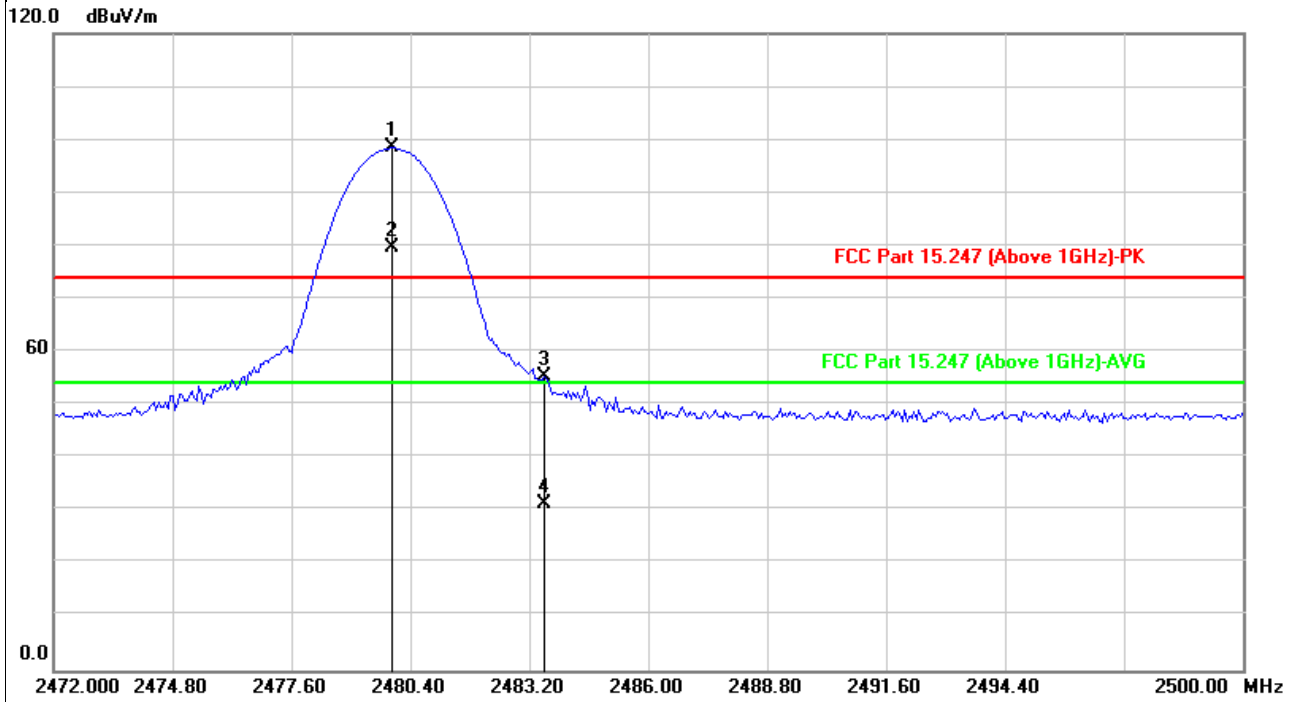

No.	Frequency (MHz)	Reading (dBuV)	Factor (dB)	Emission Level (dBuV/m)	Limit (dBuV/m)	Margin (dB)	Detector	Antenna Height (cm)	Table Angle (Degree)
1#	2479.968	97.78	0.64	98.42	74.00	24.42	peak	100	237
2#	2479.968	79.12	0.64	79.76	54.00	25.76	AVG	100	237
3	2483.559	54.58	0.63	55.21	74.00	-18.79	peak	100	237
4	2483.559	30.76	0.63	31.39	54.00	-22.61	AVG	100	237
5	4960.000	41.13	7.94	49.07	74.00	-24.93	peak	100	160
6	4960.000	31.46	7.94	39.40	54.00	-14.60	AVG	100	160
7	7440.000	34.11	11.09	45.20	74.00	-28.80	peak	100	233
8	7440.000	22.33	11.09	33.42	54.00	-20.58	AVG	100	233

Remarks:

- Emission Level = Read Level + Factor (Antenna Factor + Cable Loss - Preamp Factor)
Margin value = Emission level – Limit value
- #2480MHz: Fundamental frequency.
- The amplitude of spurious emissions attenuated more than 20 dB below the permissible value is not required to be report.



Right
Above 1GHz Data:

GFSK

Frequency Range	1GHz ~ 25GHz	Detector Function	Peak (PK) Average (AVG)
Test Channel	Channel 0		

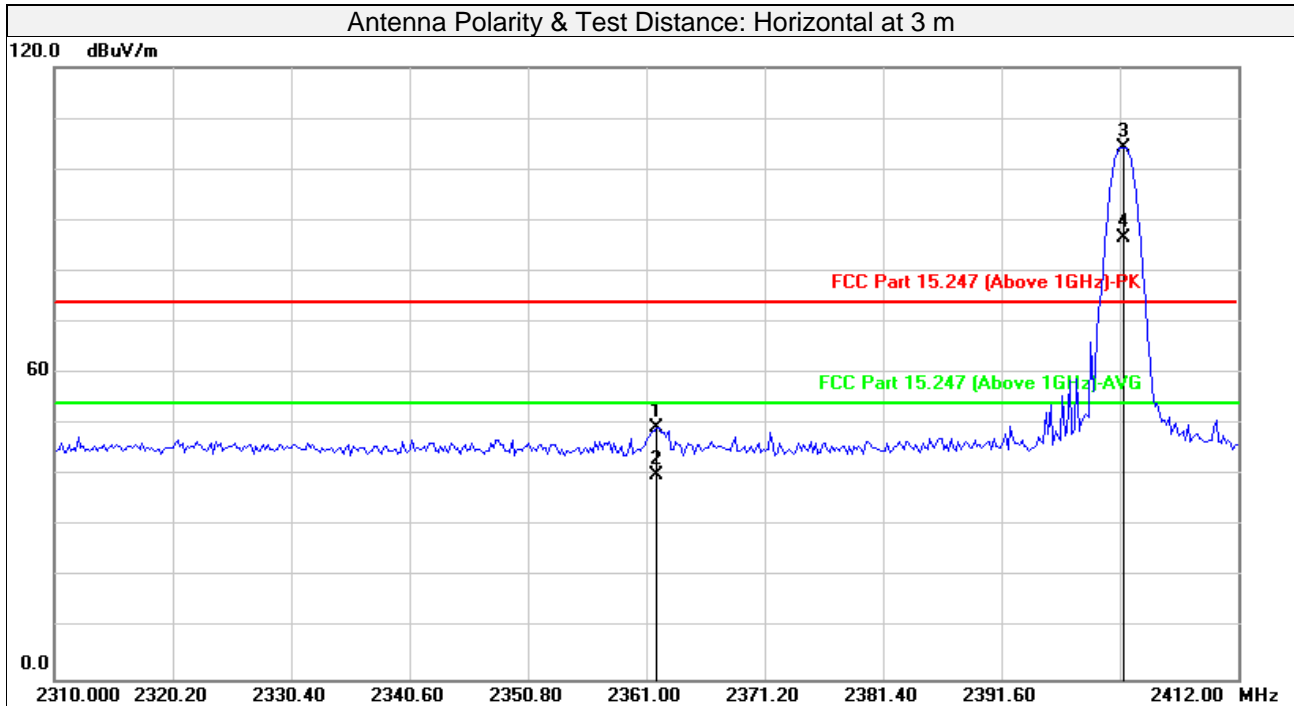

No.	Frequency (MHz)	Reading (dBuV)	Factor (dB)	Emission Level (dBuV/m)	Limit (dBuV/m)	Margin (dB)	Detector	Antenna Height (cm)	Table Angle (Degree)
1	2361.920	48.63	0.80	49.43	74.00	-24.57	peak	298	213
2	2361.920	39.25	0.80	40.05	54.00	-13.95	AVG	298	213
3#	2402.188	103.44	0.74	104.18			peak	298	213
4#	2402.188	85.76	0.74	86.50			AVG	298	213
5	4804.000	44.42	7.27	51.69	74.00	-22.31	peak	100	194
6	4804.000	34.29	7.27	41.56	54.00	-12.44	AVG	100	194
7	7206.000	35.27	10.75	46.02	74.00	-27.98	peak	100	17
8	7206.000	24.21	10.75	34.96	54.00	-19.04	AVG	100	17

Remarks:

- Emission Level = Read Level + Factor (Antenna Factor + Cable Loss - Preamp Factor)
Margin value = Emission level – Limit value
- #2402MHz: Fundamental frequency.
- The amplitude of spurious emissions attenuated more than 20 dB below the permissible value is not required to be report.



Frequency Range	1GHz ~ 25GHz	Detector Function	Peak (PK) Average (AVG)
Test Channel	Channel 0		

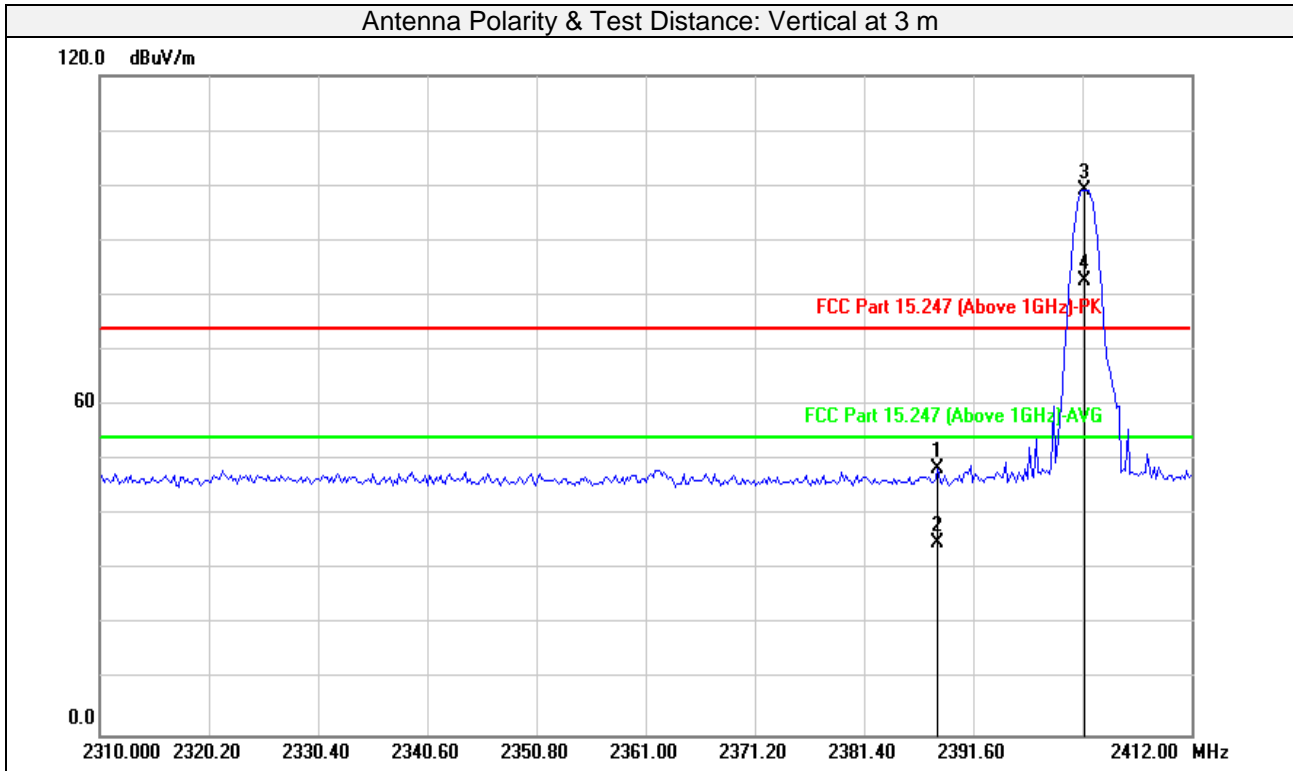

No.	Frequency (MHz)	Reading (dBuV)	Factor (dB)	Emission Level (dBuV/m)	Limit (dBuV/m)	Margin (dB)	Detector	Antenna Height (cm)	Table Angle (Degree)
1	2388.289	47.72	0.77	48.49	74.00	-25.51	peak	106	183
2	2388.289	34.05	0.77	34.82	54.00	-19.18	AVG	106	183
3#	2401.984	98.36	0.75	99.11	74.00	25.11	peak	106	183
4#	2401.984	82.01	0.75	82.76	54.00	28.76	AVG	106	183
5	4804.000	40.66	7.27	47.93	74.00	-26.07	peak	100	300
6	4804.000	33.44	7.27	40.71	54.00	-13.29	AVG	100	300
7	7206.000	36.27	10.75	47.02	74.00	-26.98	peak	100	233
8	7206.000	27.60	10.75	38.35	54.00	-15.65	AVG	100	233

Remarks:

1. Emission Level = Read Level + Factor (Antenna Factor + Cable Loss - Preamp Factor)
Margin value = Emission level – Limit value
2. #2402MHz: Fundamental frequency.
3. The amplitude of spurious emissions attenuated more than 20 dB below the permissible value is not required to be report.



Frequency Range	1GHz ~ 25GHz	Detector Function	Peak (PK) Average (AVG)
Test Channel	Channel 39		

Antenna Polarity & Test Distance: Horizontal at 3 m									
No.	Frequency (MHz)	Reading (dBuV)	Factor (dB)	Emission Level (dBuV/m)	Limit (dBuV/m)	Margin (dB)	Detector	Antenna Height (cm)	Table Angle (Degree)
1 #	2441.000	105.28	0.69	105.97			peak	100	198
2 #	2441.000	86.73	0.69	87.42			AVG	100	198
3	4882.000	44.84	7.61	52.45	74.00	-21.55	peak	100	266
4	4882.000	36.20	7.61	43.81	54.00	-10.19	AVG	100	266
5	7323.000	35.52	10.92	46.44	74.00	-27.56	peak	100	101
6	7323.000	24.59	10.92	35.51	54.00	-18.49	AVG	100	101
Antenna Polarity & Test Distance: Vertical at 3 m									
No.	Frequency (MHz)	Reading (dBuV)	Factor (dB)	Emission Level (dBuV/m)	Limit (dBuV/m)	Margin (dB)	Detector	Antenna Height (cm)	Table Angle (Degree)
1 #	2441.000	99.78	0.69	100.47			peak	100	118
2 #	2441.000	82.35	0.69	83.04			AVG	100	118
3	4882.000	41.70	7.61	49.31	74.00	-24.69	peak	100	245
4	4882.000	35.06	7.61	42.67	54.00	-11.33	AVG	100	245
5	7323.000	37.81	10.92	48.73	74.00	-25.27	peak	100	94
6	7323.000	29.63	10.92	40.55	54.00	-13.45	AVG	100	94

Remarks:

- Emission Level = Read Level + Factor (Antenna Factor + Cable Loss - Preamp Factor)
Margin value = Emission level – Limit value
- #2441MHz: Fundamental frequency.
- The amplitude of spurious emissions attenuated more than 20 dB below the permissible value is not required to be report.



Frequency Range	1GHz ~ 25GHz	Detector Function	Peak (PK) Average (AVG)
Test Channel	Channel 78		

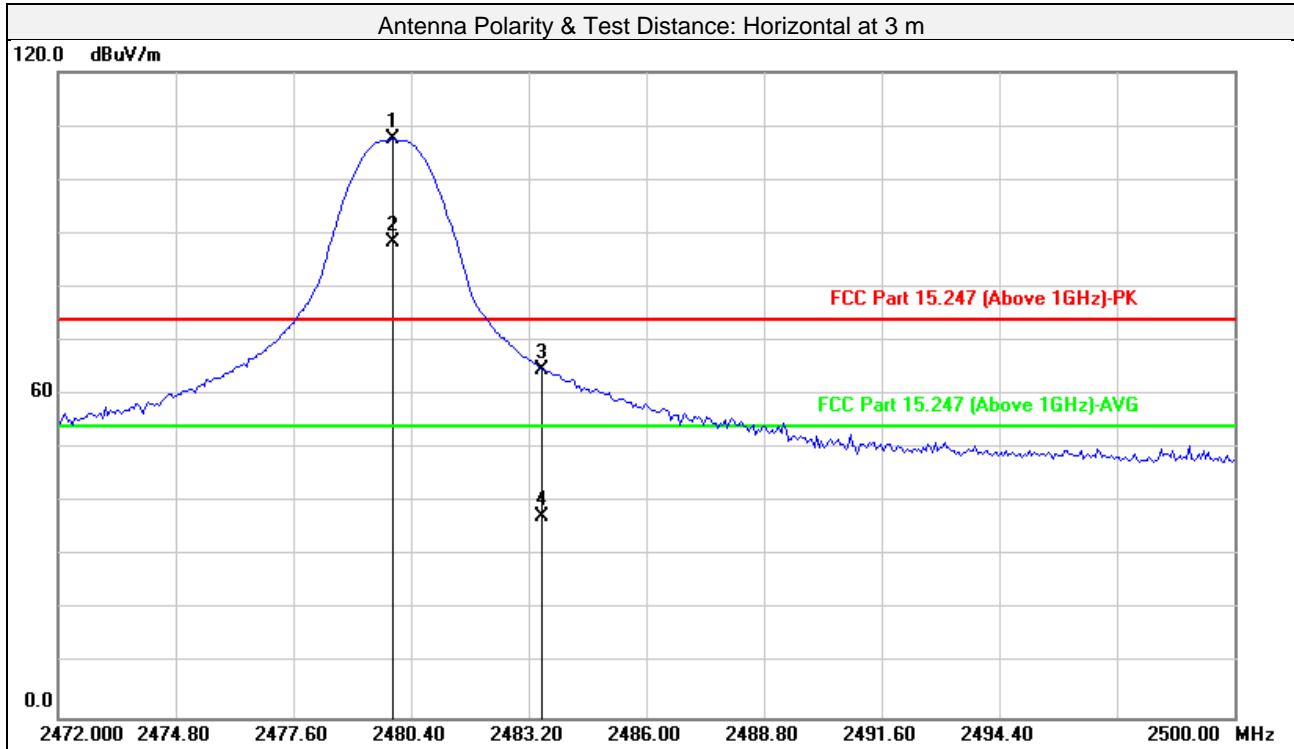

No.	Frequency (MHz)	Reading (dBuV)	Factor (dB)	Emission Level (dBuV/m)	Limit (dBuV/m)	Margin (dB)	Detector	Antenna Height (cm)	Table Angle (Degree)
1#	2479.968	106.80	0.64	107.44			peak	280	219
2#	2479.968	87.80	0.64	88.44			AVG	280	219
3	2483.500	64.09	0.63	64.72	74.00	-9.28	peak	280	219
4	2483.500	36.66	0.63	37.29	54.00	-16.71	AVG	280	219
5	4960.000	45.33	7.94	53.27	74.00	-20.73	peak	100	42
6	4960.000	38.42	7.94	46.36	54.00	-7.64	AVG	100	42
7	7440.000	35.79	11.09	46.88	74.00	-27.12	peak	100	26
8	7440.000	24.93	11.09	36.02	54.00	-17.98	AVG	100	26

Remarks:

- Emission Level = Read Level + Factor (Antenna Factor + Cable Loss - Preamp Factor)
Margin value = Emission level – Limit value
- #2480MHz: Fundamental frequency.
- The amplitude of spurious emissions attenuated more than 20 dB below the permissible value is not required to be report.



Frequency Range	1GHz ~ 25GHz	Detector Function	Peak (PK) Average (AVG)
Test Channel	Channel 78		

Antenna Polarity & Test Distance: Vertical at 3 m

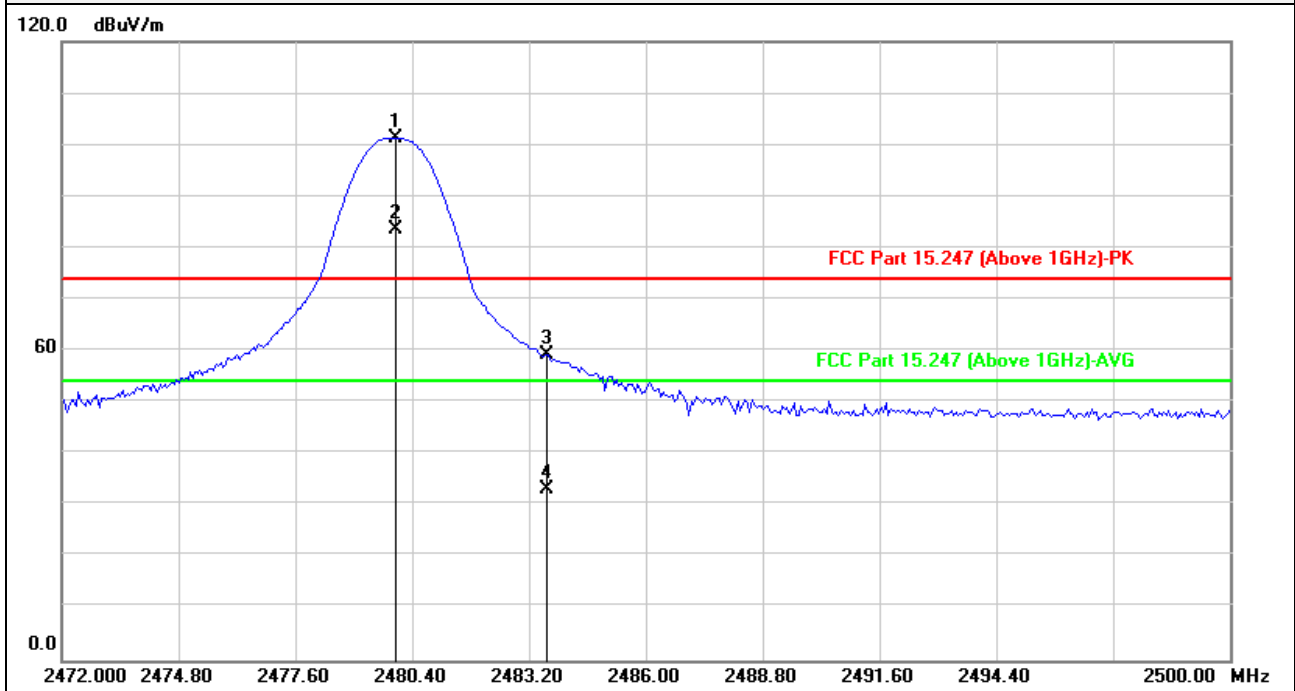

No.	Frequency (MHz)	Reading (dBuV)	Factor (dB)	Emission Level (dBuV/m)	Limit (dBuV/m)	Margin (dB)	Detector	Antenna Height (cm)	Table Angle (Degree)
1#	2480.024	100.54	0.64	101.18			peak	100	195
2#	2480.024	83.00	0.64	83.64			AVG	100	195
3	2483.615	58.61	0.63	59.24	74.00	-14.76	peak	100	195
4	2483.615	32.43	0.63	33.06	54.00	-20.94	AVG	100	195
5	4960.000	43.58	7.94	51.52	74.00	-22.48	peak	100	322
6	4960.000	35.81	7.94	43.75	54.00	-10.25	AVG	100	322
7	7440.000	39.33	11.09	50.42	74.00	-23.58	peak	100	230
8	7440.000	31.02	11.09	42.11	54.00	-11.89	AVG	100	230

Remarks:

- Emission Level = Read Level + Factor (Antenna Factor + Cable Loss - Preamp Factor)
Margin value = Emission level – Limit value
- #2480MHz: Fundamental frequency.
- The amplitude of spurious emissions attenuated more than 20 dB below the permissible value is not required to be report.



8DPSK

Frequency Range	1GHz ~ 25GHz	Detector Function	Peak (PK) Average (AVG)
Test Channel	Channel 0		

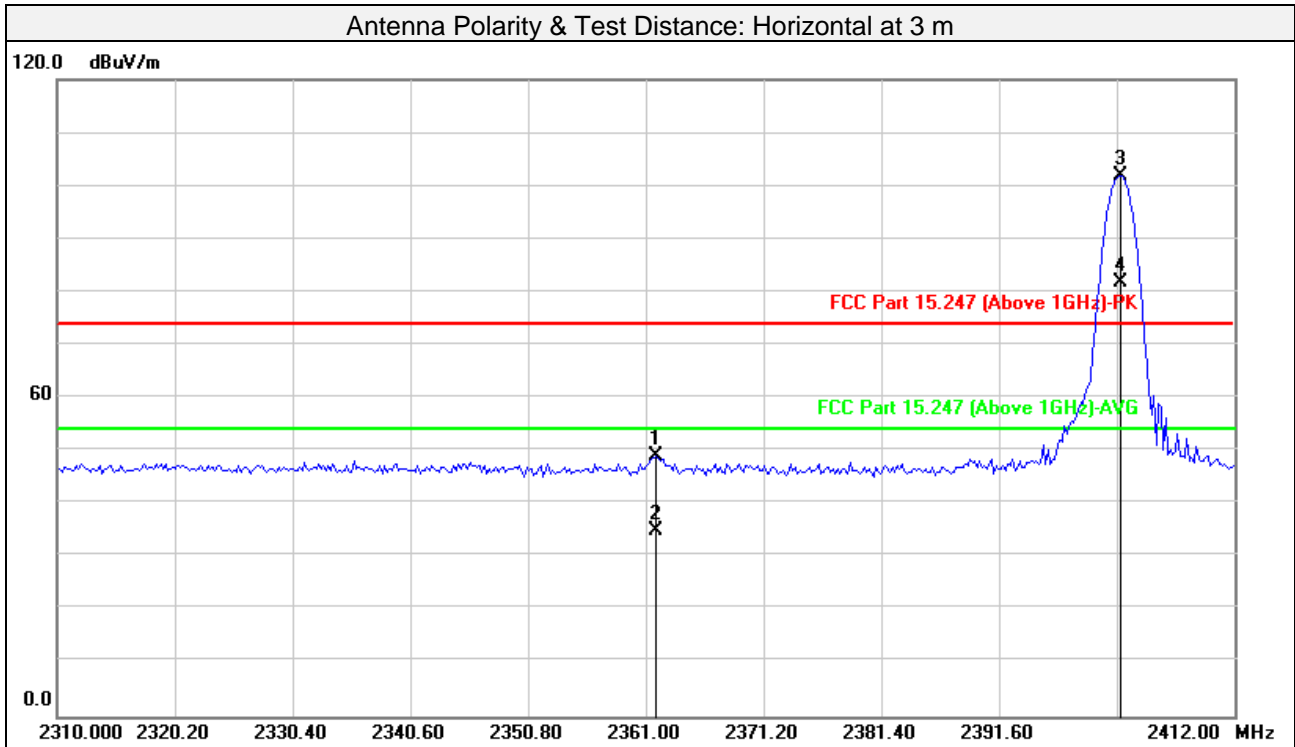

No.	Frequency (MHz)	Reading (dBuV)	Factor (dB)	Emission Level (dBuV/m)	Limit (dBuV/m)	Margin (dB)	Detector	Antenna Height (cm)	Table Angle (Degree)
1	2361.920	48.35	0.80	49.15	74.00	-24.85	peak	100	1
2	2361.920	34.18	0.80	34.98	54.00	-19.02	AVG	100	1
3#	2402.188	101.09	0.74	101.83	74.00	27.83	peak	100	1
4#	2402.188	80.91	0.74	81.65	54.00	27.65	AVG	100	1
5	4804.000	49.60	7.27	56.87	74.00	-17.13	peak	100	236
6	4804.000	39.08	7.27	46.35	54.00	-7.65	AVG	100	236
7	7206.000	38.19	10.75	48.94	74.00	-25.06	peak	100	237
8	7206.000	26.00	10.75	36.75	54.00	-17.25	AVG	100	237

Remarks:

- Emission Level = Read Level + Factor (Antenna Factor + Cable Loss - Preamp Factor)
Margin value = Emission level – Limit value
- #2402MHz: Fundamental frequency.
- The amplitude of spurious emissions attenuated more than 20 dB below the permissible value is not required to be report.



Frequency Range	1GHz ~ 25GHz	Detector Function	Peak (PK) Average (AVG)
Test Channel	Channel 0		

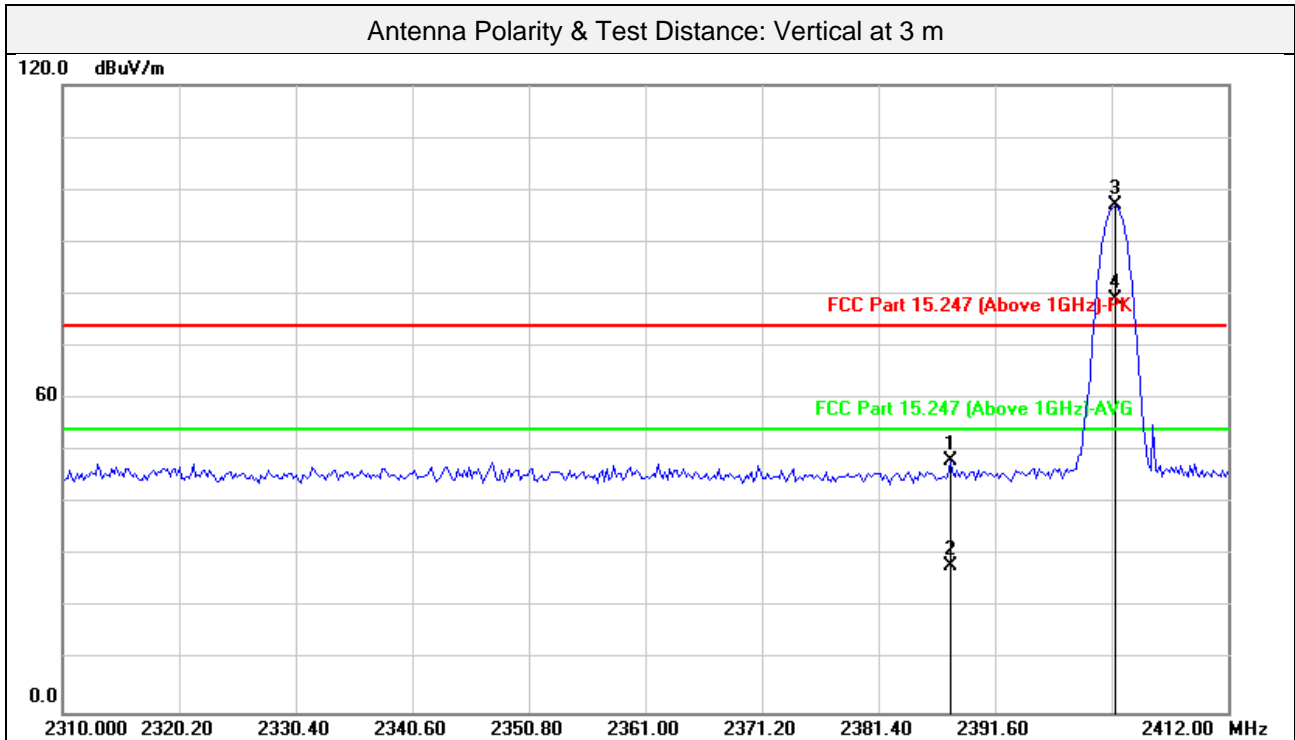

No.	Frequency (MHz)	Reading (dBuV)	Factor (dB)	Emission Level (dBuV/m)	Limit (dBuV/m)	Margin (dB)	Detector	Antenna Height (cm)	Table Angle (Degree)
1	2387.675	47.43	0.77	48.20	74.00	-25.80	peak	100	347
2	2387.675	27.21	0.77	27.98	54.00	-26.02	AVG	100	347
3#	2402.188	96.18	0.74	96.92			peak	100	347
4#	2402.188	78.25	0.74	78.99			AVG	100	347
5	4804.000	45.80	7.27	53.07	74.00	-20.93	peak	100	186
6	4804.000	35.29	7.27	42.56	54.00	-11.44	AVG	100	186
7	7206.000	36.81	10.75	47.56	74.00	-26.44	peak	100	288
8	7206.000	24.39	10.75	35.14	54.00	-18.86	AVG	100	288

Remarks:

1. Emission Level = Read Level + Factor (Antenna Factor + Cable Loss - Preamp Factor)
Margin value = Emission level – Limit value
2. #2402MHz: Fundamental frequency.
3. The amplitude of spurious emissions attenuated more than 20 dB below the permissible value is not required to be report.



Frequency Range	1GHz ~ 25GHz	Detector Function	Peak (PK) Average (AVG)
Test Channel	Channel 39		

Antenna Polarity & Test Distance: Horizontal at 3 m									
No.	Frequency (MHz)	Reading (dBuV)	Factor (dB)	Emission Level (dBuV/m)	Limit (dBuV/m)	Margin (dB)	Detector	Antenna Height (cm)	Table Angle (Degree)
1#	2441.000	101.92	0.69	102.61			peak	100	102
2#	2441.000	80.75	0.69	81.44			AVG	100	102
3	4882.000	48.17	7.61	55.78	74.00	-18.22	peak	100	169
4	4882.000	37.01	7.61	44.62	54.00	-9.38	AVG	100	169
5	7323.000	36.56	10.92	47.48	74.00	-26.52	peak	100	58
6	7323.000	25.16	10.92	36.08	54.00	-17.92	AVG	100	58
Antenna Polarity & Test Distance: Vertical at 3 m									
No.	Frequency (MHz)	Reading (dBuV)	Factor (dB)	Emission Level (dBuV/m)	Limit (dBuV/m)	Margin (dB)	Detector	Antenna Height (cm)	Table Angle (Degree)
1#	2441.000	98.12	0.69	98.81			peak	100	222
2#	2441.000	79.63	0.69	80.32			AVG	100	222
3	4882.000	44.05	7.61	51.66	74.00	-22.34	peak	100	301
4	4882.000	34.18	7.61	41.79	54.00	-12.21	AVG	100	301
5	7323.000	37.15	10.92	48.07	74.00	-25.93	peak	100	155
6	7323.000	26.02	10.92	36.94	54.00	-17.06	AVG	100	155

Remarks:

4. Emission Level = Read Level + Factor (Antenna Factor + Cable Loss - Preamp Factor)
Margin value = Emission level – Limit value
5. #2441MHz: Fundamental frequency.
6. The amplitude of spurious emissions attenuated more than 20 dB below the permissible value is not required to be report.



Frequency Range	1GHz ~ 25GHz	Detector Function	Peak (PK) Average (AVG)
Test Channel	Channel 78		

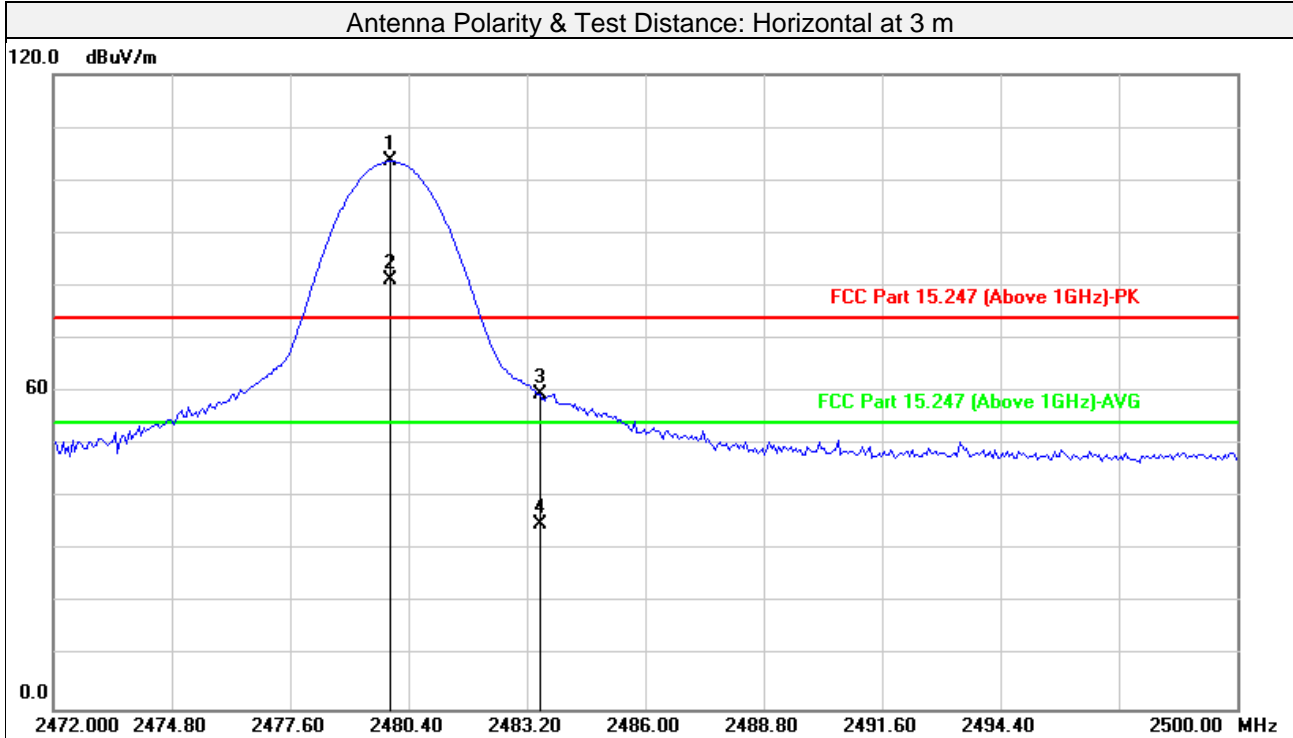

No.	Frequency (MHz)	Reading (dBuV)	Factor (dB)	Emission Level (dBuV/m)	Limit (dBuV/m)	Margin (dB)	Detector	Antenna Height (cm)	Table Angle (Degree)
1#	2479.968	102.93	0.64	103.57			peak	100	73
2#	2479.968	80.58	0.64	81.22			AVG	100	73
3	2483.500	58.96	0.63	59.59	74.00	-14.41	peak	100	73
4	2483.500	34.33	0.63	34.96	54.00	-19.04	AVG	100	73
5	4960.000	45.39	7.94	53.33	74.00	-20.67	peak	100	41
6	4960.000	35.90	7.94	43.84	54.00	-10.16	AVG	100	41
7	7440.000	34.40	11.09	45.49	74.00	-28.51	peak	100	12
8	7440.000	24.00	11.09	35.09	54.00	-18.91	AVG	100	12

Remarks:

1. Emission Level = Read Level + Factor (Antenna Factor + Cable Loss - Preamp Factor)
Margin value = Emission level – Limit value
2. #2480MHz: Fundamental frequency.
3. The amplitude of spurious emissions attenuated more than 20 dB below the permissible value is not required to be report.



Frequency Range	1GHz ~ 25GHz	Detector Function	Peak (PK) Average (AVG)
Test Channel	Channel 78		

Antenna Polarity & Test Distance: Vertical at 3 m

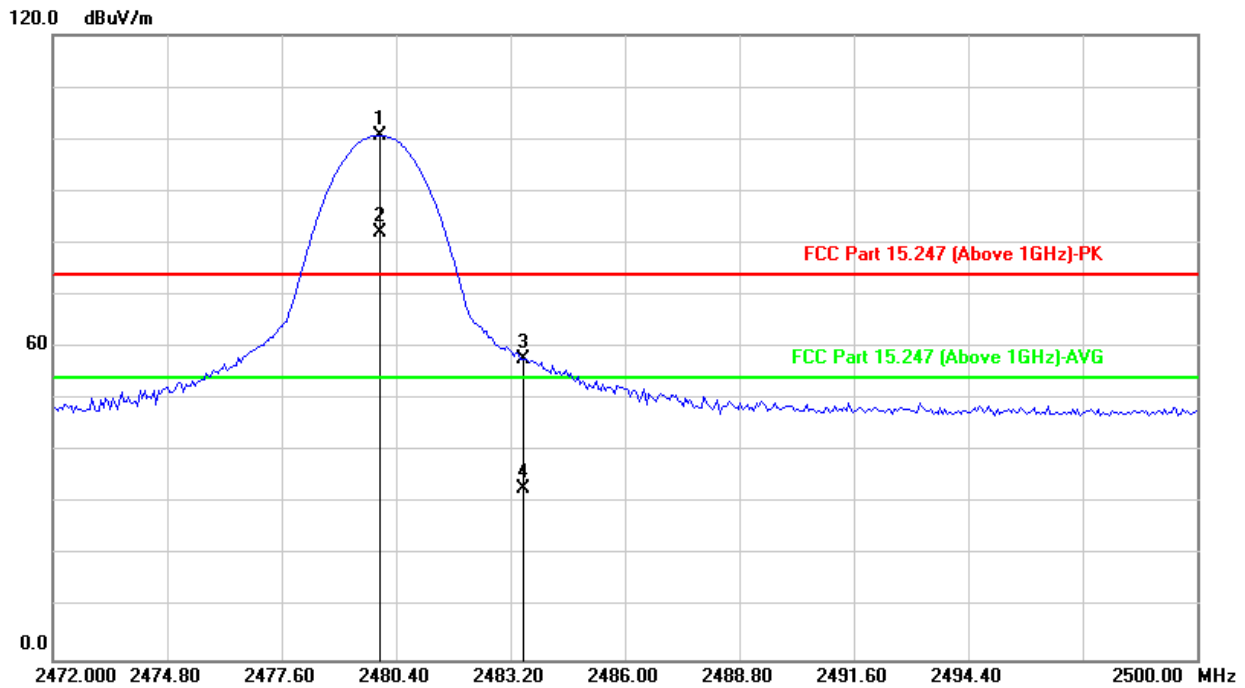

No.	Frequency (MHz)	Reading (dBuV)	Factor (dB)	Emission Level (dBuV/m)	Limit (dBuV/m)	Margin (dB)	Detector	Antenna Height (cm)	Table Angle (Degree)
1#	2480.024	100.15	0.64	100.79			peak	100	324
2#	2480.024	81.46	0.64	82.10			AVG	100	324
3	2483.500	57.20	0.63	57.83	74.00	-16.17	peak	100	324
4	2483.500	32.17	0.63	32.80	54.00	-21.20	AVG	100	324
5	4960.000	42.03	7.94	49.97	74.00	-24.03	peak	106	321
6	4960.000	32.59	7.94	40.53	54.00	-13.47	AVG	106	321
7	7440.000	37.69	11.09	48.78	74.00	-25.22	peak	100	226
8	7440.000	27.26	11.09	38.35	54.00	-15.65	AVG	100	226

Remarks:

- Emission Level = Read Level + Factor (Antenna Factor + Cable Loss - Preamp Factor)
Margin value = Emission level – Limit value
- #2480MHz: Fundamental frequency.
- The amplitude of spurious emissions attenuated more than 20 dB below the permissible value is not required to be report.



3.2 Conducted Emission Measurement

3.2.1 Limits of Conducted Emission Measurement

Frequency (MHz)	Conducted Limit (dBuV)	
	Quasi-peak	Average
0.15 - 0.5	66 - 56	56 - 46
0.50 - 5.0	56	46
5.0 - 30.0	60	50

Note: 1. The lower limit shall apply at the transition frequencies.
2. The limit decreases in line with the logarithm of the frequency in the range of 0.15 to 0.50MHz.

3.2.2 Test Instruments

Description & Manufacturer	Model No.	Serial No.	Due Date of Calibration
EMI Test Receiver Rohde&Schwarz	ESR 7	101961	2023-01-13
Artificial Mains Network Rohde&Schwarz	ENV216	3560.6550.15	2023-01-12
Test software FARAD	EZ_EMCC V1.1.4.2	N/A	N/A

Note: 1. The calibration interval of the above test instruments is 12 months.
2. The test was performed in Shielded Room 1.



3.2.3 Test Procedures

- The EUT was placed 0.4 meters from the conducting wall of the shielded room with EUT being connected to the power mains through a line impedance stabilization network (LISN). Other support units were connected to the power mains through another LISN. The two LISNs provide 50 ohm/ 50uH of coupling impedance for the measuring instrument.
- Both lines of the power mains connected to the EUT were checked for maximum conducted interference.
- The frequency range from 150kHz to 30MHz was searched. Emission levels under (Limit – 20dB) was not recorded.

Note: All modes of operation were investigated and the worst-case emissions are reported.

3.2.4 Test Setup

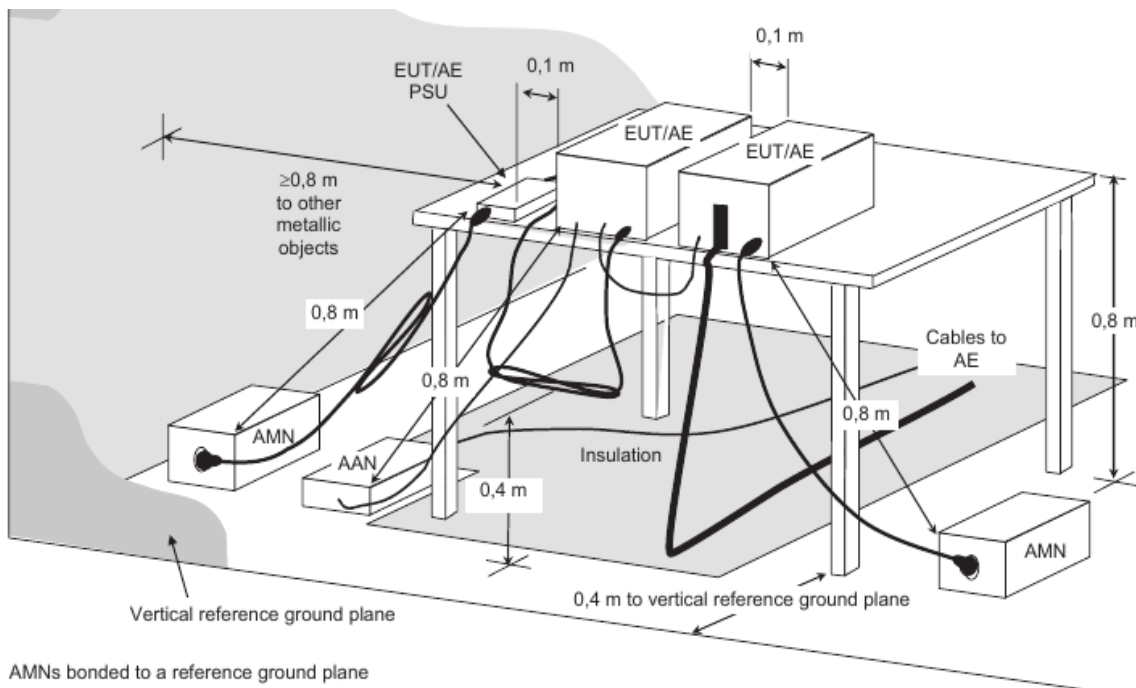

For the actual test configuration, please refer to the attached file (Test Setup Photo).

3.2.5 EUT Operating Condition

Set the EUT under transmission condition continuously at specific channel frequency.

3.2.6 Deviation from Test Standard

No deviation.



3.2.7 Test Results

Frequency Range	150kHz ~ 30MHz	Detector Function & Resolution bandwidth	Quasi-Peak (QP) / Average (AV), 9kHz
-----------------	----------------	--	--------------------------------------

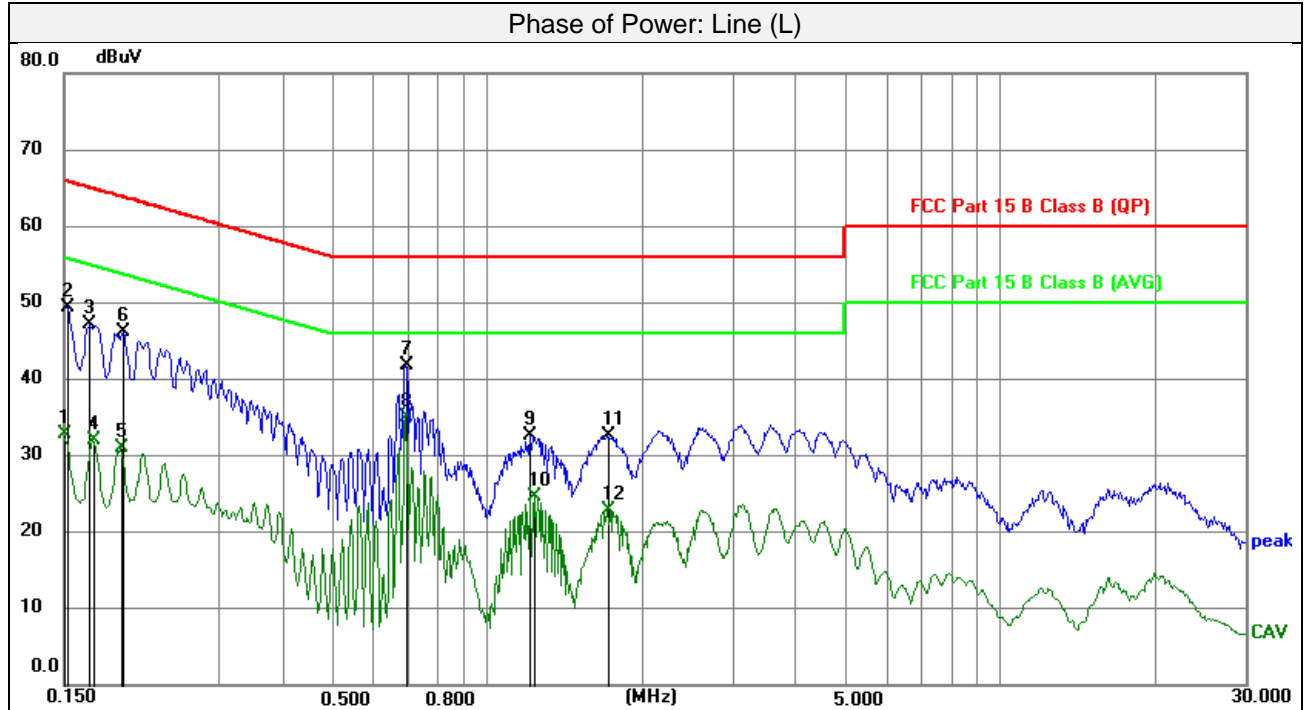

No.	Frequency (MHz)	Reading (dBuV)	Correction Factor (dB)	Emission Level (dBuV)	Limit (dBuV)	Margin (dB)	Remark
1	0.1500	22.57	10.19	32.76	56.00	-23.24	AVG
2	0.1522	39.19	10.18	49.37	65.88	-16.51	peak
3	0.1680	37.03	10.17	47.20	65.06	-17.86	peak
4	0.1703	21.90	10.16	32.06	54.95	-22.89	AVG
5	0.1928	20.87	10.15	31.02	53.92	-22.90	AVG
6	0.1949	35.98	10.14	46.12	63.83	-17.71	peak
7	0.6945	31.68	10.10	41.78	56.00	-14.22	peak
8	0.6945	24.93	10.10	35.03	46.00	-10.97	AVG
9	1.2142	22.52	10.06	32.58	56.00	-23.42	peak
10	1.2390	14.65	10.06	24.71	46.00	-21.29	AVG
11	1.7183	22.52	10.09	32.61	56.00	-23.39	peak
12	1.7183	12.84	10.09	22.93	46.00	-23.07	AVG

Remarks:

1. Q.P. and AV. are abbreviations of quasi-peak and average individually.
2. The emission levels of other frequencies were very low against the limit.
3. Margin value = Emission level - Limit value
4. Correction factor = Insertion loss + Cable loss
5. Emission Level = Correction Factor + Reading Value.



Frequency Range	150kHz ~ 30MHz	Detector Function & Resolution andwidth	Quasi-Peak (QP) / Average (AV), 9kHz
-----------------	----------------	---	--------------------------------------

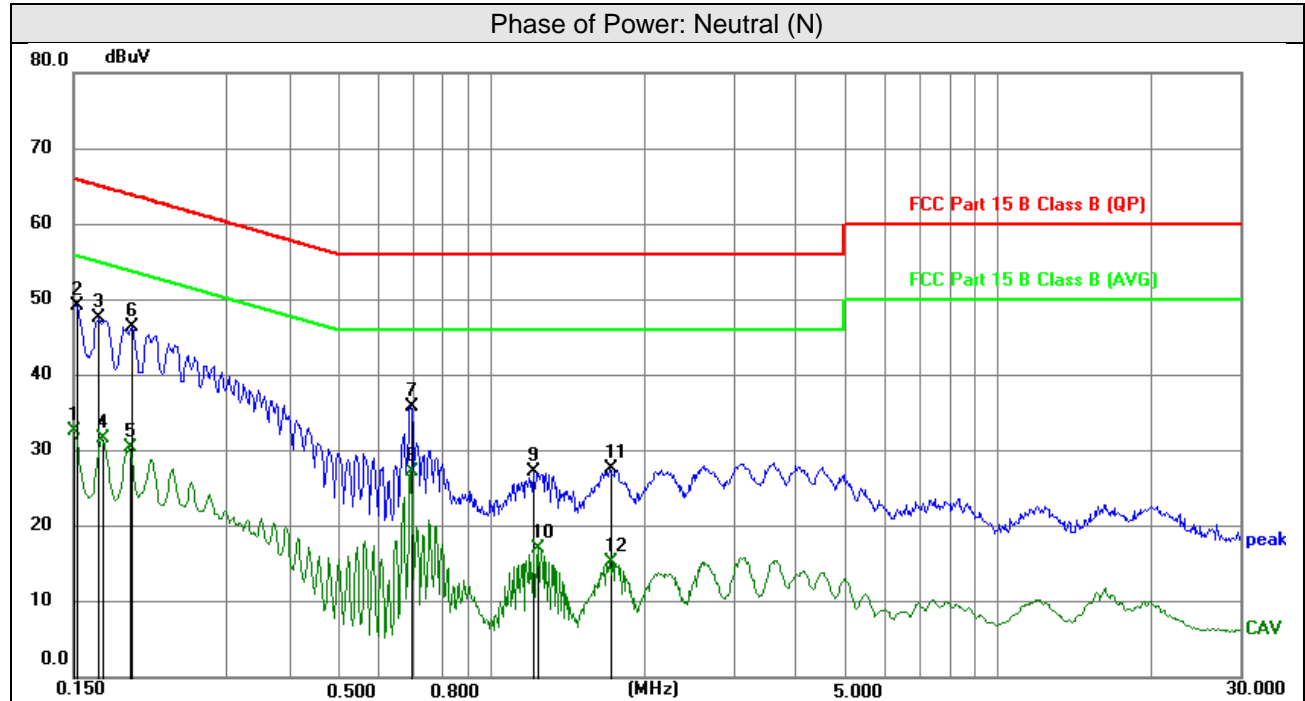

No.	Frequency	Reading	Correct Factor	Emission Level	Limit	Margin	Remark
	(MHz)	(dBuV)	dB	(dBuV)	(dBuV)	(dB)	Detector
1	0.1500	22.44	10.19	32.63	56.00	-23.37	AVG
2	0.1522	39.08	10.18	49.26	65.88	-16.62	peak
3	0.1680	37.38	10.17	47.55	65.06	-17.51	peak
4	0.1703	21.42	10.16	31.58	54.95	-23.37	AVG
5	0.1928	20.36	10.15	30.51	53.92	-23.41	AVG
6	0.1949	36.26	10.14	46.40	63.83	-17.43	peak
7	0.6945	25.64	10.10	35.74	56.00	-20.26	peak
8	0.6945	17.04	10.10	27.14	46.00	-18.86	AVG
9	1.2142	17.23	10.06	27.29	56.00	-28.71	peak
10	1.2390	7.07	10.06	17.13	46.00	-28.87	AVG
11	1.7183	17.45	10.09	27.54	56.00	-28.46	peak
12	1.7183	5.21	10.09	15.30	46.00	-30.70	AVG

Remarks:

1. Q.P. and AV. are abbreviations of quasi-peak and average individually.
2. The emission levels of other frequencies were very low against the limit.
3. Margin value = Emission level - Limit value
4. Correction factor = Insertion loss + Cable loss
5. Emission Level = Correction Factor + Reading Value.



3.3 Number of Hopping Frequency Used

3.3.1 Limits of Hopping Frequency Used Measurement

At least 15 channels frequencies, and should be equally spaced.

3.3.2 Test Setup

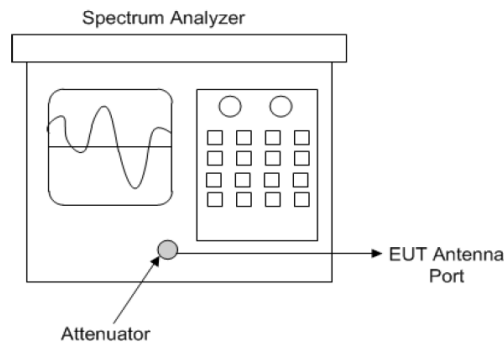

Spectrum analyzer test configuration

3.3.3 Test Instruments

Refer to section 5 to get information of above instrument.

3.3.4 Test Procedure

- Check the calibration of the measuring instrument (SA) using either an internal calibrator or a known signal from an external generator.
- Turn on the EUT and connect its antenna terminal to measurement via a low loss cable. Then set it to any one measured frequency within its operating range and make sure the instrument is operated in its linear range.
- Set the SA on MaxHold Mode, and then keep the EUT in hopping mode. Record all the signals from each channel until each one has been recorded.
- Set the SA on View mode and then plot the result on SA screen.
- Repeat above procedures until all frequencies measured were complete.

3.3.5 Deviation from Test Standard

No deviation.



3.3.6 Test Results

There are 79 hopping frequencies in the hopping mode. Please refer to next page for the test result. On the plots, it shows that the hopping frequencies are equally spaced.

Left

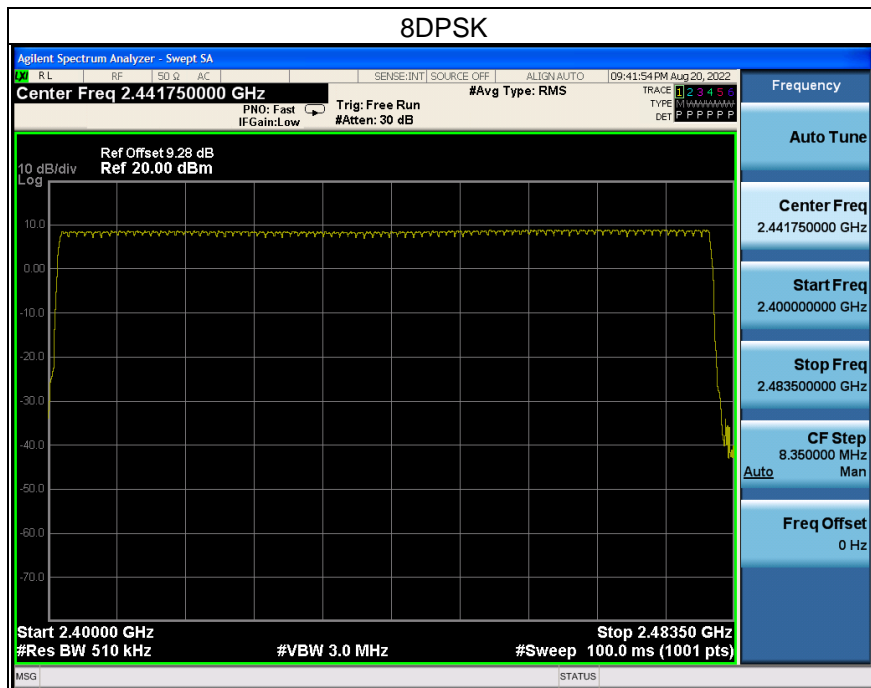
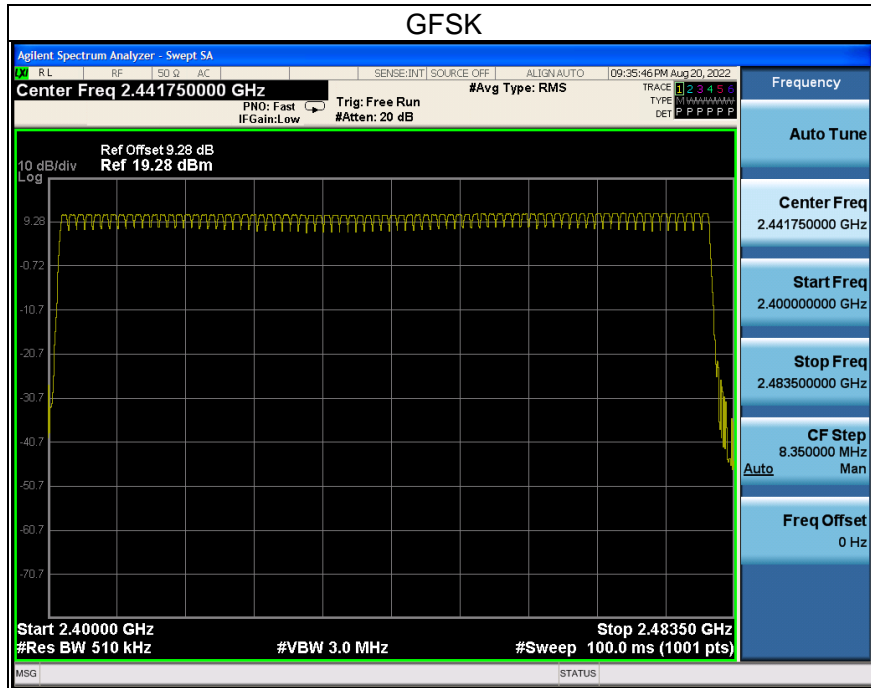



Right

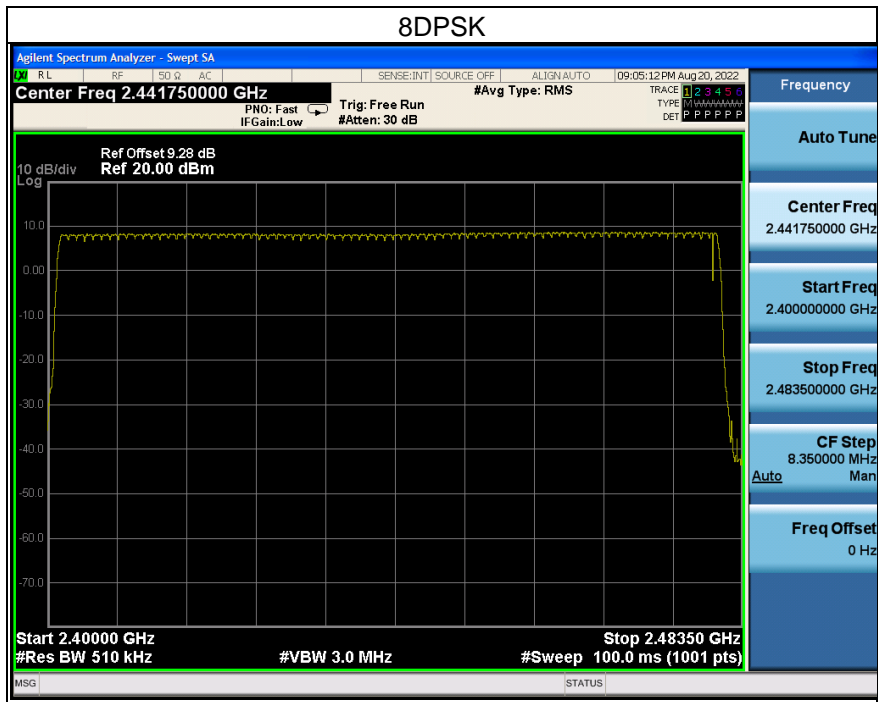
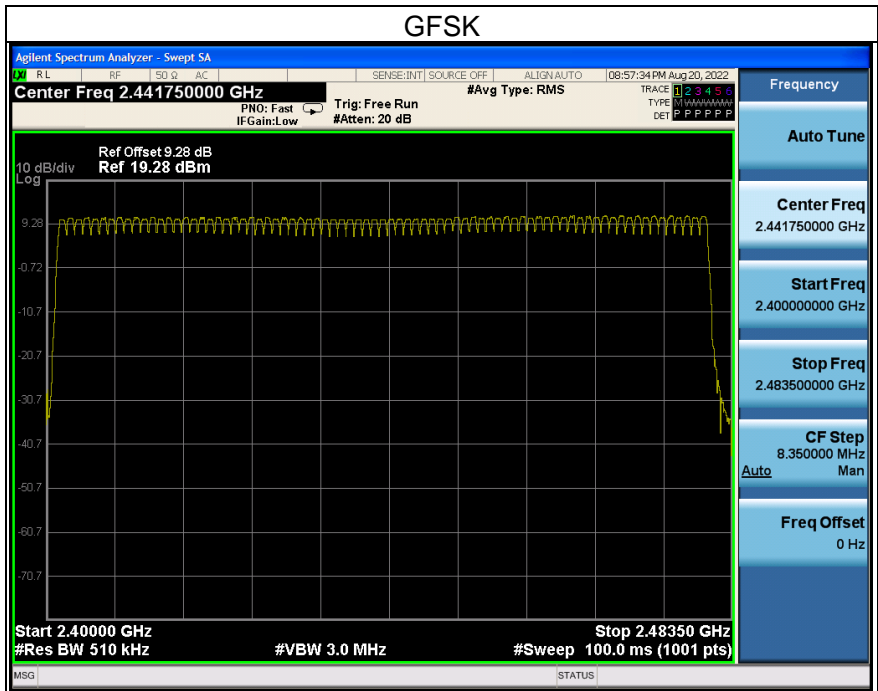



3.4 Channel Bandwidth

3.4.1 Limits of Channel Bandwidth Measurement

For frequency hopping system operating in the 2400-2483.5 MHz, if the 20 dB bandwidth of hopping channel is greater than 25 kHz, two-thirds 20 dB bandwidth of hopping channel shall be a minimum limit for the hopping channel separation.

3.4.2 Test Setup

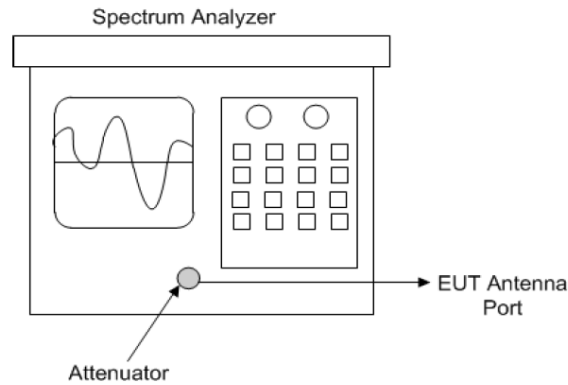

Spectrum analyzer test configuration

3.4.3 Test Instruments

Refer to section 5 to get information of above instrument.

3.4.4 Test Procedure

- Check the calibration of the measuring instrument using either an internal calibrator or a known signal from an external generator.
- Turn on the EUT and connect it to measurement instrument. Then set it to any one convenient frequency within its operating range. Set a reference level on the instrument equal to the highest peak value.
- Measure the frequency difference of two frequencies that were attenuated 20 dB from the reference level. Record the frequency difference as the emission bandwidth.
- Repeat above procedures until all frequencies measured were complete.

3.4.5 Deviation from Test Standard

No deviation.

3.4.6 EUT Operating Condition

The software provided by client enabled the EUT to transmit and receive data at lowest, middle and highest channel frequencies individually.



3.4.7 Test Results

Left

Channel	Frequency (MHz)	20dB Bandwidth (MHz)	
		GFSK	8DPSK
0	2402	0.966	1.311
39	2441	0.966	1.302
78	2480	0.951	1.356

Right

Channel	Frequency (MHz)	20dB Bandwidth (MHz)	
		GFSK	8DPSK
0	2402	0.963	1.308
39	2441	0.966	1.326
78	2480	0.966	1.293



Left





Right





3.5 Hopping Channel Separation

3.5.1 Limits of Hopping Channel Separation Measurement

At least 25 kHz or two-third of 20 dB hopping channel bandwidth (whichever is greater).

3.5.2 Test Setup

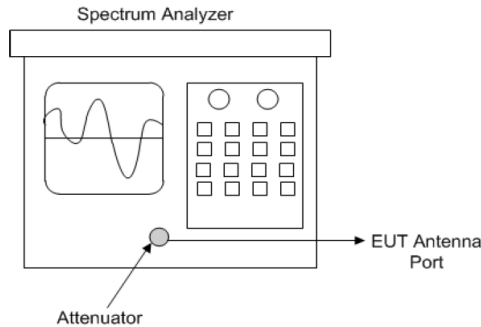

3.5.3 Test Instruments

Refer to section 5 to get information of above instrument.

3.5.4 Test Procedure

- Check the calibration of the measuring instrument using either an internal calibrator or a known signal from an external generator.
- Turn on the EUT and connect it to measurement instrument. Then set it to any one convenient frequency within its operating range.
- By using the MaxHold function record the separation of two adjacent channels.
- Measure the frequency difference of these two adjacent channels by SA MARK function. And then plot the result on SA screen.
- Repeat above procedures until all frequencies measured were complete.

3.5.5 Deviation from Test Standard

No deviation.

3.5.6 Test Results

Left

Channel No.	Frequency (MHz)	Adjacent Channel Separation (MHz)		Minimum Limit (MHz)		Pass / Fail
		GFSK	8DPSK	GFSK	8DPSK	
0	2402	1.005	1.002	0.644	0.874	Pass
39	2441	0.999	1.011	0.644	0.868	Pass
78	2480	0.999	1.005	0.634	0.904	Pass

Note:The minimum limit is two-third 20 dB bandwidth.





Right

Channel No.	Frequency (MHz)	Adjacent Channel Separation (MHz)		Minimum Limit (MHz)		Pass / Fail
		GFSK	8DPSK	GFSK	8DPSK	
0	2402	1.005	1.002	0.642	0.872	Pass
39	2441	0.999	1.011	0.644	0.884	Pass
78	2480	0.999	1.005	0.644	0.862	Pass

Note: The minimum limit is two-third 20 dB bandwidth.

Right





3.6 Maximum Output Power

3.6.1 Limits of Maximum Output Power Measurement

The Maximum Output Power Measurement is 125mW.

3.6.2 Test Setup

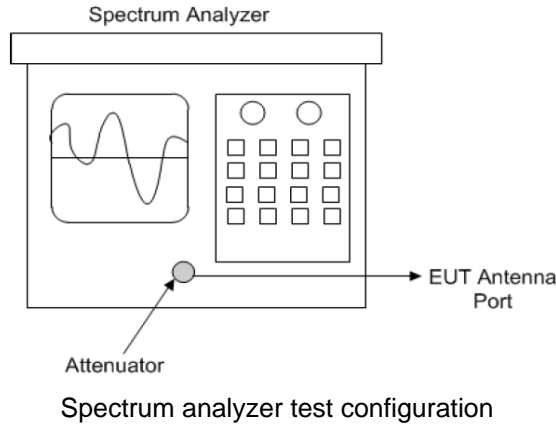

3.6.3 Test Instruments

Refer to section 5 to get information of above instrument.

3.6.4 Test Procedure

- Measurement using a spectrum analyzer (SA), Selection of test method:
- Maximum peak conducted output power

The following procedure shall be used when an instrument with a resolution bandwidth that is greater than the DTS bandwidth is available to perform the measurement:

- a) Set the RBW > DTS bandwidth.
- b) Set VBW > [3 x RBW]
- c) Set span > [3 x RBW]
- d) Sweep time = auto couple.
- e) Detector = peak
- f) Trace mode = max hold.
- g) Allow trace to fully stabilize.
- h) Use peak marker function to determine the peak amplitude level.



- Maximum conducted (average) output power
- a) Check the calibration of the measuring instrument using either an internal calibrator or a known signal from an external generator.
- b) Turn on the EUT and connect it to measurement instrument. Then set it to any one convenient frequency within its operating range. Set a reference level on the measuring instrument equal to the highest peak value.
- c) SA Setting:
 - 1)* Set span to at least 1.5 times the OBW
 - 2)* Set sweep trigger to "free run."
 - 3)* Set RBW= 1% to 5% of the OBW. not to exceed 1MHz.
 - 4)* Set VBW $\geq 3 \times$ RBW
 - 5)* Number of points in sweep $\geq 2 \times$ span /RBW. (This gives bin-to-bin spacing \leq RBW / 2. so that narrowband signals are not lost between frequency bins).
 - 6)* Sweep time \leq (number of points in sweep) x T. where T is defined in 11.6. If this gives a sweep time less than the auto sweep time of the instrument. then method AVGSA-3 shall not be used (use AVGSA-3A). The purpose of this step is so that the averaging time in each bin is less than or equal to the minimum time of a transmission.
 - 7)* Detector =RMS (power averaging).
 - 8)* Trace mode =Max hold.
 - 9)* Allow max hold to run for at least 60 s or longer as needed to allow the trace to stabilize.
 - 10)* Compute power by integrating the spectrum across the OBW of the signal using the instrument's band power measurement function with band limits set equal to the OBW band edges. If the instrument does not have a band power function. then sum the spectrum levels (in power units) at intervals equal to the RBW extending across the entire OBW.
- d. Measure the captured power within the band and recording the plot.
- e. Repeat above procedures until all frequencies required were complete.

3.6.5 Deviation from Test Standard

No deviation.

3.6.6 EUT Operating Condition

The software provided by client enabled the EUT to transmit and receive data at lowest, middle and highest channel frequencies individually.



3.6.7 Test Results

Left

Peak power

Channel No.	Freq. (MHz)	Output Power (mW)		Output Power (dBm)		Power Limit (mW)	Pass / Fail
		GFSK	8DPSK	GFSK	8DPSK		
0	2402	12.647	12.717	11.020	11.044	125	Pass
39	2441	12.045	12.291	10.808	10.896	125	Pass
78	2480	12.844	13.262	11.087	11.226	125	Pass

Average power

Channel No.	Freq. (MHz)	Output Power (mW)		Output Power (dBm)		Power Limit (mW)	Pass / Fail
		GFSK	8DPSK	GFSK	8DPSK		
0	2402	4.975	1.711	6.968	2.332	125	Pass
39	2441	4.757	1.052	6.773	0.222	125	Pass
78	2480	5.242	1.102	7.195	0.420	125	Pass

Note: The test result had been added the duty cycle factor.

Right

Peak power

Channel No.	Freq. (MHz)	Output Power (mW)		Output Power (dBm)		Power Limit (mW)	Pass / Fail
		GFSK	8DPSK	GFSK	8DPSK		
0	2402	11.392	12.255	10.566	10.883	125	Pass
39	2441	11.601	12.073	10.645	10.818	125	Pass
78	2480	12.485	13.125	10.964	11.181	125	Pass

Average power

Channel No.	Freq. (MHz)	Output Power (mW)		Output Power (dBm)		Power Limit (mW)	Pass / Fail
		GFSK	8DPSK	GFSK	8DPSK		
0	2402	5.114	1.539	7.088	1.872	125	Pass
39	2441	4.716	1.598	6.736	2.036	125	Pass
78	2480	5.047	1.686	7.030	2.268	125	Pass

Note: The test result had been added the duty cycle factor.



Left

Peak Power Spectrum Plot

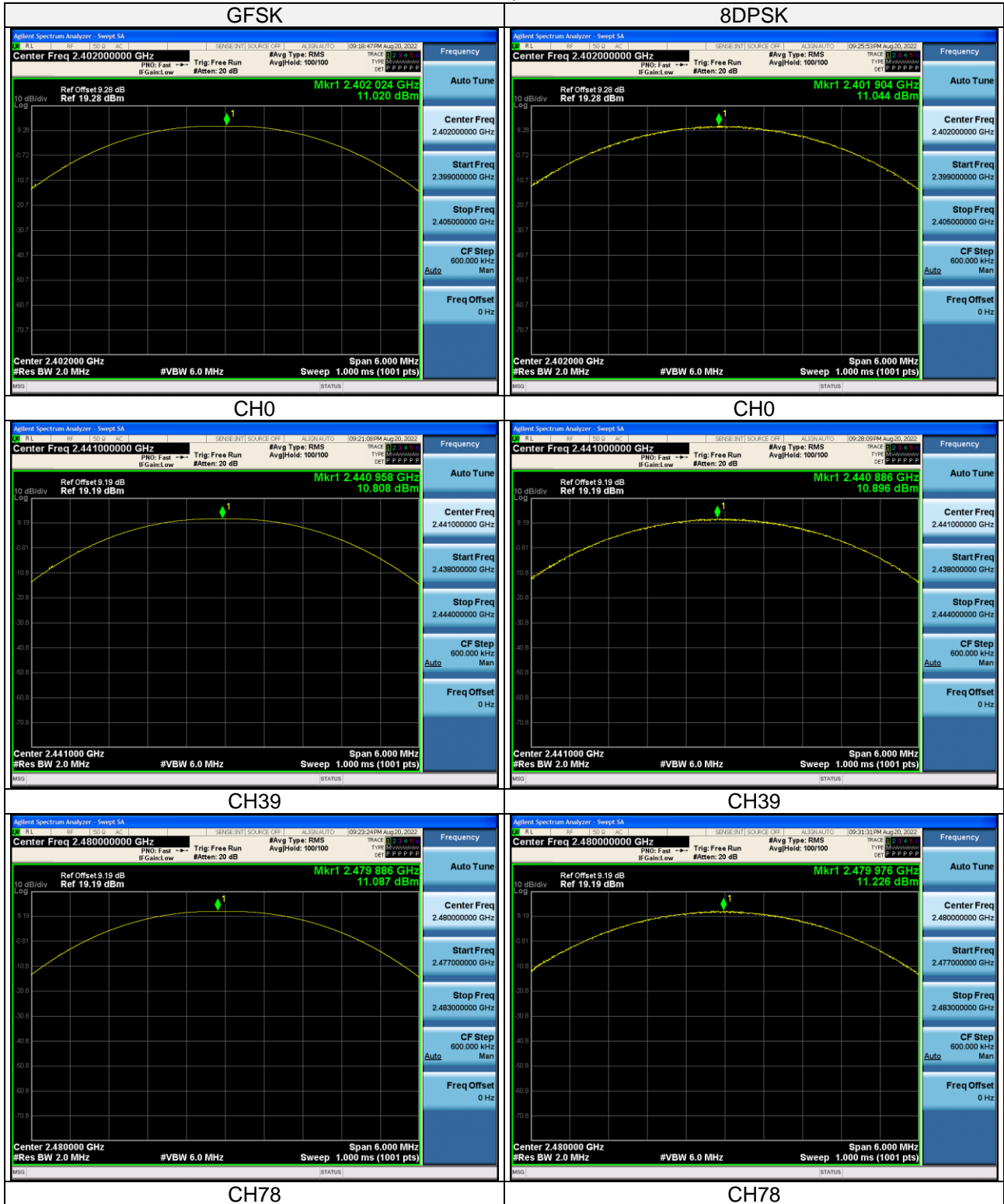



Average Power Spectrum Plot

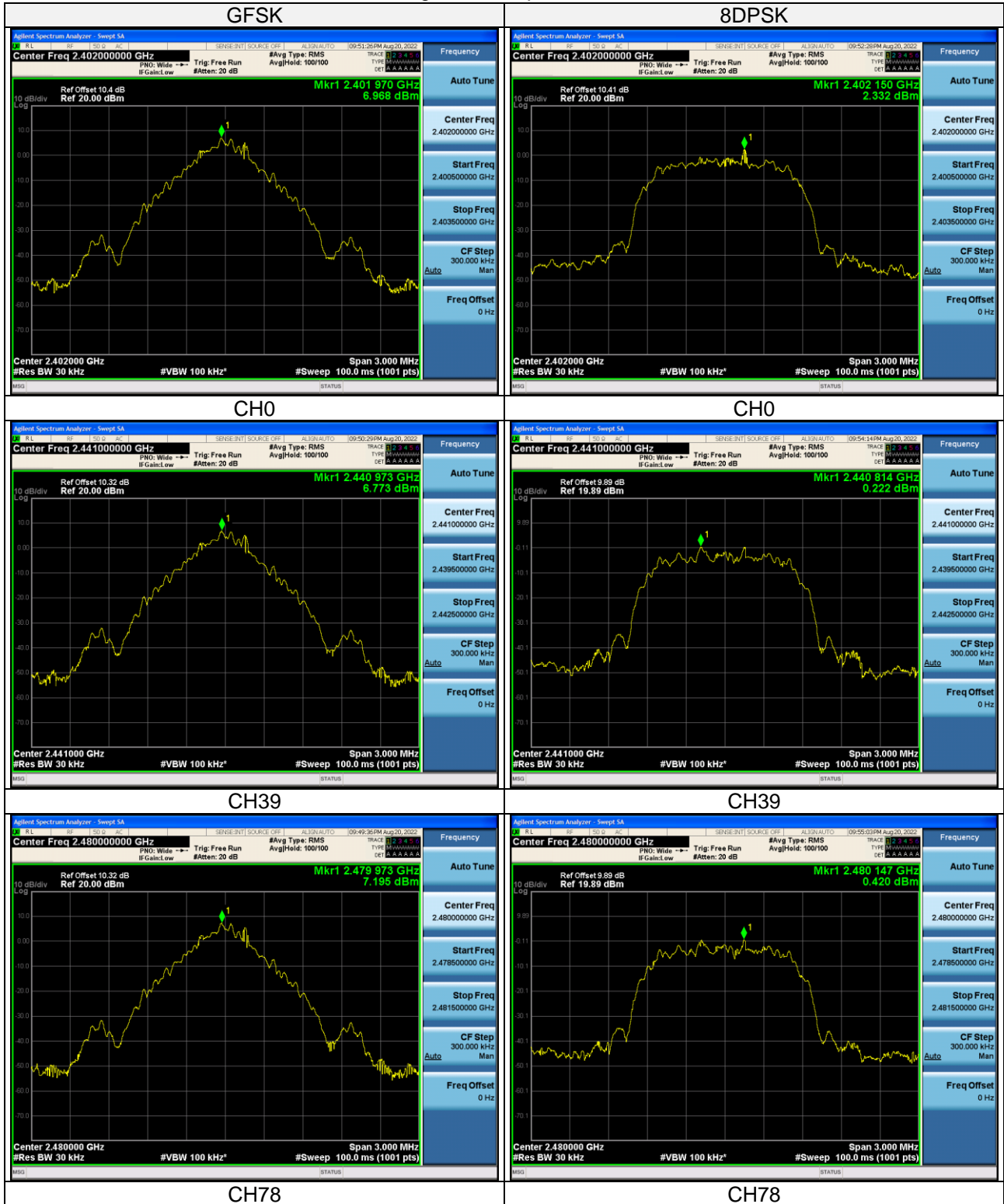



Right

Peak Power Spectrum Plot

