

VIVITAR®

# Air Rover

Jumbo RC Helicopter



RECHARGEABLE  
LITHIUM BATTERY



REMOTE  
CONTROL



LIGHTWEIGHT  
CONSTRUCTION



**USER'S MANUAL**

ITEM: DRC252

# 1. Introduction

Thank you for purchasing the Vivitar Air Rover, item DRC252. The included remote controlled aircraft is designed specifically for outdoor flying. In order to get the best possible results, please read this user's manual carefully before using. In addition, be sure to keep this manual in a safe place for future reference.

# 2. Package Contents

- Air Rover Jumbo RC Helicopter
- Remote Control
- USB Charging Cable
- 1 Tail Blade
- User's Manual with Warranty Information

### 3. Important Safety Precautions

When using your Air Rover, basic safety precautions should always be followed, including the following:

1. Do not allow children or the infirm to operate your helicopter without adult supervision. For safety purposes, only allow experienced pilots aged 14 and up fly your helicopter.
2. To avoid choking hazards, keep all small parts and pieces away from children.
3. Your helicopter is not a toy. Make sure that it is properly assembled before use, and operated safely.
4. Keep your helicopter away from obstacles, crowds, power lines, trees, and bodies of water while it is in flight. Always fly your helicopter in a wide open, spacious environment. Avoid flying your helicopter directly above people or animals. Maintain a 7ft (2m) distance from the aircraft when taking off and landing.
5. Only use your helicopter in a dry environment. Your helicopter is composed of sophisticated electronic components and parts. To avoid damage to your helicopter, please keep it away from water and moisture. Use a soft dry cloth to wipe the surface of your helicopter and keep it clean.
6. Beginner and novice level pilots should practice flying with experienced pilots until suitably experienced in flight.
7. To ensure safety, only use the included parts when using your helicopter.
8. Make sure to keep your ears and eyes protected when using your helicopter. When your helicopter's blades are spinning, make sure to keep people and objects at a distance from rotating parts.
9. Keep your helicopter away from excessive heat or flames, especially while charging the battery.
10. Please recycle or dispose of your helicopter properly based on the laws and rules of your municipality. Contact local recycling facilities and/or the manufacturer of your helicopter for further information.

## 4. A Quick Look at Your Device

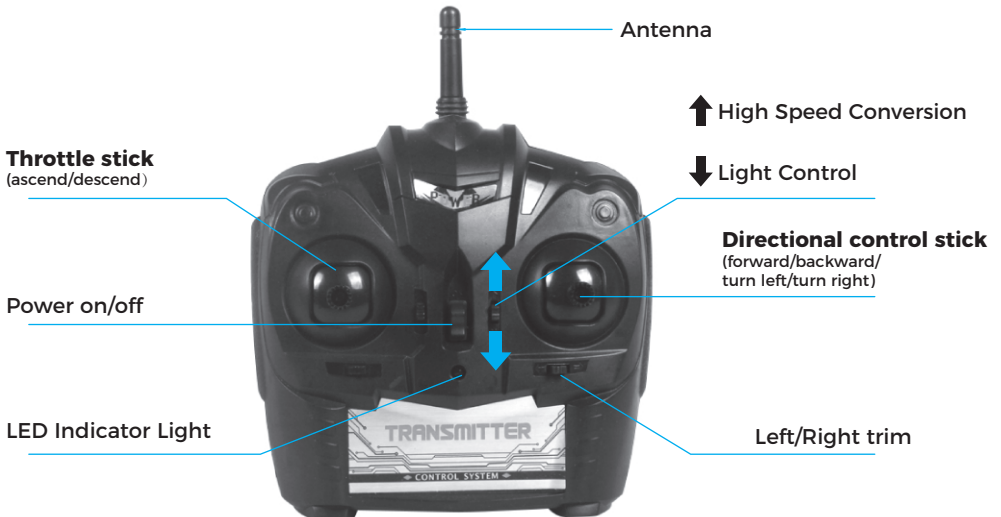
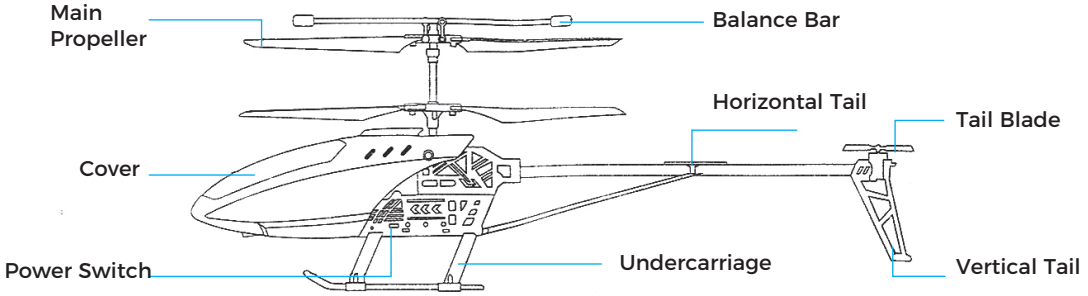

## 5. Inserting Batteries Into Your Remote Control

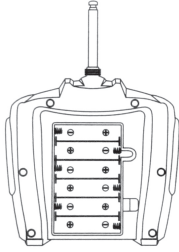

Screw the antenna onto the top of the remote control. Then, use a screwdriver to open up the battery compartment located on the rear of your remote control.

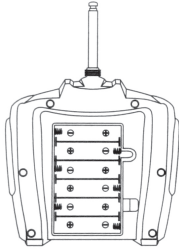
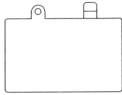

Insert 4 AA 1.5V batteries (not included), making sure that the batteries are inserted with the correct polarity (+, -) as displayed in the battery compartment.

Once the batteries are inserted, put the battery compartment cover back on the battery compartment, and use a screwdriver to close it securely.

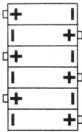

4 "AA" Batteries  
(Not Included)



- Do not mix rechargeable and non-rechargeable batteries.
- Do not mix old and new batteries or different types of batteries.
- Remove exhausted batteries and dispose of them based on the rules of your local municipality.
- Remove the batteries from your remote control if it will not be in use for an extended period of time.

## 6. Charging Your Helicopter's Battery

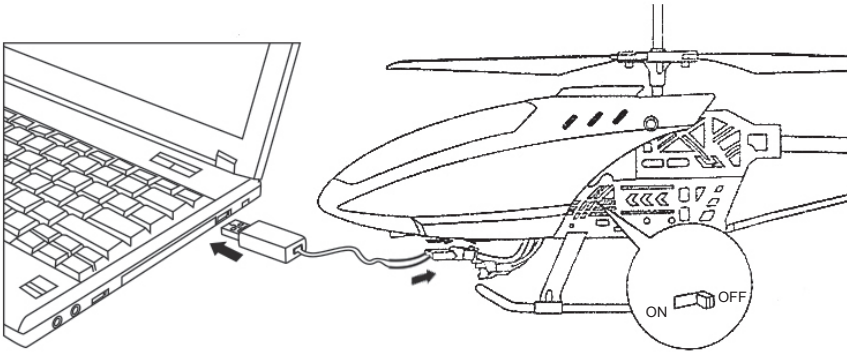

Your helicopter has a built in 3.7V 1200mAh battery. Before charging your helicopter, make sure that the ON/OFF switch is in the OFF position.

Unplug the charging cable from the helicopter's receiving board, and connect it to the included USB charging adapter.

Then plug the USB charging adapter into a suitable USB charging port.

An LED light on the helicopter's circuit board will turn RED while the battery is charging, and then turn green when charging is complete.

Once charging is complete connect the charging cable back into the helicopter's receiving board.

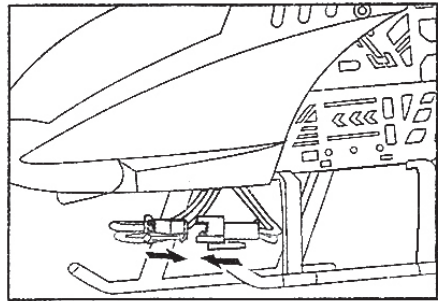

### **WARNING:**

1. Unplug the charger when charging is complete to avoid damaging the battery.
2. Do not leave the battery unattended when charging.
3. Do not use other chargers other than the one supplied.
4. Wait at least 30 minutes after using your chopper before charging the battery. The battery's temperature can become elevated during use and charging it immediately could damage the battery.
5. Do not leave the battery exposed to excessive heat, flame or fire.

## 7. Flying Your Helicopter

### Pre-Flight Preparation

If you have never piloted an aircraft before and you are not an experienced pilot, make sure to read these instructions carefully before flying. Get familiar with all of the controls. If necessary, read through these instructions many times and practice handling the remote control until you feel completely comfortable and ready.

1. Place your helicopter in a clear, open field. Make sure that it is resting on a secure, flat surface.
2. Avoid flying in extreme temperatures or windy conditions.
3. Practice using the throttle stick and the directional control stick (see below).
4. By simulating the use of the remote and both sticks, you will grow more comfortable with the natural motions required during flight and you will learn to react more rapidly to unexpected circumstances.

### Powering ON/Synchronizing

Slide the helicopter's ON/OFF switch to the ON position, and also slide the remote's Power On/OFF switch to the ON position to power on both devices so that you can begin flying.

Push the throttle stick all the way up, and then pull it all the way down to synchronize your remote with your helicopter. The LED indicator light should shine steadily when you are ready for flight. If the indicator light begins flashing, your battery needs to be recharged.



Push the throttle stick upwards and the helicopter will ascend.

Pull the throttle stick downwards and the helicopter will descend.



Push the directional control stick upwards and the helicopter will tilt downwards, causing it to move forward.



Push the directional control stick downwards and the helicopter will tilt upwards, causing it to move backwards.

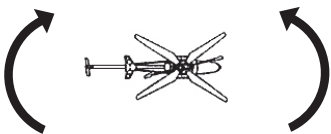

Slide the directional control stick to the left and the helicopter will turn to the left.

Slide the directional control stick to the right and the helicopter will turn to the right.

## 8. Adjusting the Trim

Push the trim button to make minor adjustments in the direction the aircraft is tilted. Adjust the trim accordingly to make compensations so that the helicopter straightens out.



Left/Right trim

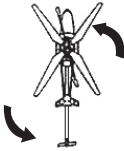

Helicopter spins to the left.

Push the trim button to the right until the helicopter stops spinning.

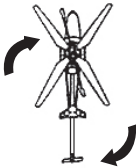

Helicopter spins to the right.

Push the trim button to the left until the helicopter stops spinning.



## 9. Troubleshooting

**PROBLEM:** No response from remote.

**CAUSE:** Batteries not correctly inserted.

**SOLUTION:** Make sure the batteries are inserted with the correct polarity (+,-).

**CAUSE:** Batteries are drained.

**SOLUTION:** Remove the batteries from the remote and insert new, fresh batteries.

**PROBLEM:** Remote not controlling helicopter .

**CAUSE:** Helicopter is not receiving signal from remote.

**SOLUTION:** Point the remote directly at the helicopter and bring the remote closer to the helicopter. Move away from direct sunlight.

**CAUSE:** Low battery.

**SOLUTION:** Remove the batteries from the remote and insert new, fresh batteries.

**PROBLEM:** The helicopter is not flying high enough.

**CAUSE:** Rotor speed is too slow.

**SOLUTION:** Push the control stick up for more rotor speed.

**CAUSE:** Batteries are drained.

**SOLUTION:** Fully charge the helicopter before using.

## 10. Specifications

**LENGTH:** 625mm

**WIDTH:** 148mm

**HEIGHT:** 238mm

**WEIGHT:** 318g

**BATTERY:** 3.7V 1200mAh Rechargeable Lithium Ion

**Charging Time:** approximately 130 minutes

**Flight Time:** approximately 6 minutes

## FCC Compliance Statement

Changes or modifications not expressly approved by the party responsible for compliance could void the user's authority to operate the equipment.

This device complies with Part 15 of the FCC Rules. Operation is subject to the following two conditions: (1) this device may not cause harmful interference, and (2) this device must accept any interference received, including interference that may cause undesired operation.

This equipment has been tested and found to comply with the limits for a Class B digital device, pursuant to Part 15 of the FCC Rules. These limits are designed to provide reasonable protection against harmful interference in a residential installation. This equipment generates, uses and can radiate radio frequency energy and, if not installed and used in accordance with the instructions, may cause harmful interference to radio communications. However, there is no guarantee that interference will not occur in a particular installation.

If this equipment does cause harmful interference to radio or television reception, which can be determined by turning the equipment off and on, the user is encouraged to try to correct the interference by one or more of the following measures:

- Reorient or relocate the receiving antenna.
- Increase the separation between the equipment and receiver.
- Connect the equipment into an outlet on a circuit different from that to which the receiver is connected.
- Consult the dealer or an experienced radio/TV technician for help.

# Vivitar One Year Warranty

This warranty covers the original consumer purchaser only and is not transferable.

This warranty covers products that fail to function properly UNDER NORMAL USAGE, due to defects in material or workmanship. Your product will be repaired or replaced at no charge for parts or labor for a period of one year.

## **What Is Not Covered by Warranty**

Damages or malfunctions not resulting from defects in material or workmanship and damages or malfunctions from other than normal use, including but limited to, repair by unauthorized parties, tampering, modification or accident.

## **To Obtain Warranty Service and Troubleshooting Information:**

Call 1-800-592-9541 in the U.S. or visit our website at [www.vivitar.com](http://www.vivitar.com).

To receive Warranty service along with the name and address of an authorized product service center, the original consumer purchaser must contact us for problem determination and service procedures. Proof of purchase in the form of a bill of sale or receipted invoice, evidencing that the product is within the applicable Warranty period(s), MUST be presented in order to obtain the requested service. It is your responsibility to properly package and send any defective products along with a dated copy of proof of purchase, a written explanation of the problem, and a valid return address to the authorized service center at your expense. Do not include any other items or accessories with the defective product. Any products received by the authorized service center that are not covered by warranty will be returned unrepai red.

# VIVITAR®

©2021 Sakar International  
195 Carter Drive,  
Edison, NJ 08817  
Support: 800 592 9541  
[www.vivitar.com](http://www.vivitar.com)