



BC

360 SKYVIEW

GPS VIDEO DRONE **2**



DRC-889 USER'S MANUAL



GPS

Important Pre-Flight Preparation

This section introduces essential information to guide you with using your VTI 360 SKYVIEW 2 GPS VIDEO DRONE.

Pre-Flight: Documentation

Read the following included documents before using your 360 SKEYEview Video Drone for the first time:

1. The VTI 360 SKYVIEW 2 GPS VIDEO DRONE Quick Start Guide
2. The VTI 360 SKYVIEW 2 GPS VIDEO DRONE User Manual
3. Safety Tips (Safety Guidelines and Disclaimer)

Pre-Flight: Video Tutorials

It is recommended to watch the video tutorials in order to best prepare for your first flight.

Scan the QR code or go to this address to watch the videos:

Show the QR CODE



Pre-Flight: Download the [VTI 360 SKYVIEW 2] App

Use the [VTI 360 SKYVIEW 2] app to fly your SkeyeView Drone. Scan the QR Code to download the app.



You can also download the [VTI 360 SKYVIEW 2] app from the Apple App Store or Google Play Store.

The Android version is compatible with 6.0 and later. The iOS version is compatible with iOS 9.0 or later.

Pre-Fight Checklist

Check that the Propellers are Firmly Attached (see page 4)

Insert 4 AA Batteries to the Remote (see page 5)

Charge Your Drone's Battery (see page 10)

Calibrate Your Drone with the Remote Control (see page 12)

Calibrate Your Drone's Gyroscope (see page 13)

Complete the Compass Calibration Process (see page 13)

Unlock Your Drone (see page 14)



WARNING:

Failure to calibrate your drone before flight can lead to severe flight malfunctions and potential damage to your drone. Always fly carefully!

Product Profile

This section introduces functions and installation guidelines of the SkeyeView Drone.

Important Note: FAA REGISTRATION

Owners of a drone that weighs more than 0.55 lbs. (250 g) and less than 55 lbs. (25 kg) must register their UAS online at the FAA website, <https://www.faa.gov/uas/registration>. After receiving the certificate of registration, a unique FAA registration number will be provided and it must be marked on the Drone by any means, such as permanent marker, label, engraving, or other means, as long as the number is readily accessible and maintained in a condition that is readable and legible upon close visual inspection.

Please Read This User Manual

Thank you for purchasing the VTI 360 SKYVIEW 2 GPS VIDEO DRONE, item DRC-889. The included Remote Controlled aircraft is designed specifically for outdoor flying. In order to get the best possible results, please read this manual carefully before using. In addition, be sure to keep this manual in a safe place for future reference.

Introduction

The VTI 360 SKYVIEW 2 GPS VIDEO DRONE includes an aircraft, a remote controller with a mobile phone holder, rechargeable battery, Fisheye HD camera, replacement propellers, landing gear, protection rings, and charging cable.

The technology used features auto hovering, one-key return, a flight range of 1000 feet, 10 minutes of total flight time.

The VTI 360 SKYVIEW 2 GPS VIDEO DRONE is also equipped with 1080p Full HD Video, headless mode directional lock, easy USB plug-in for charging, and variable speed settings.

Video Tutorials

It is recommended to watch the video tutorials in order to best prepare for your first flight.

Scan the QR code or go to this address to watch the videos:



Setting Up Your VTI 360 SKYVIEW 2 GPS VIDEO DRONE

Setting Up Your 360 SkEYView Video Drone

Battery Installation

Once your battery is fully charged it can be inserted directly into the battery slot of the underside of your drone.

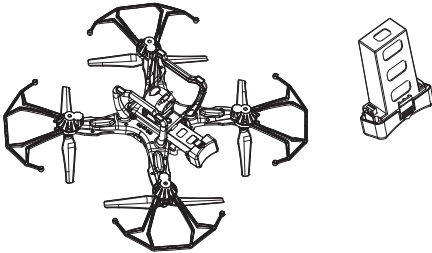

Installing Your Drone's Landing Gear

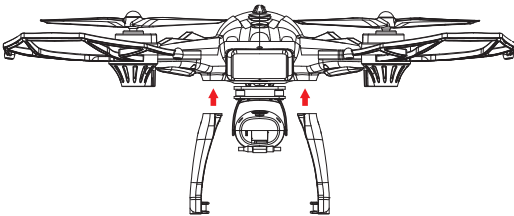

Installing Your Drone's Protection Rings

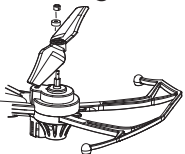

Remove the cap covering the propeller.

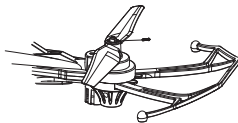

Unscrew the propeller so that your current propeller can be removed and replaced with a new one.

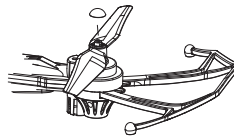

Screw the new propeller on and then place the cap back on the propeller.

Setting Up the Remote Controller

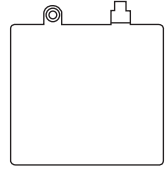
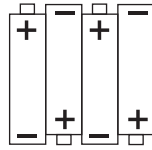
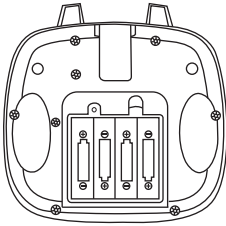

Use a screwdriver to open up the battery compartment located on the rear of your remote control.

Insert 4 AA 1.5V batteries, making sure that the batteries are inserted with the correct polarity (+,-) as displayed in the battery compartment.

Once the batteries are inserted, put the battery compartment cover back on the battery compartment, and use a screwdriver to close it securely.



- Do not mix rechargeable and non-rechargeable batteries.
- Do not mix old and new batteries or different types of batteries.
- Remove exhausted batteries and dispose of them based on the rules of your local municipality.
- Remove the batteries from your remote control if it will not be in use for an extended period of time.

A Quick Look at Your VTI 360 SKYVIEW 2 GPS VIDEO DRONE

Aircraft

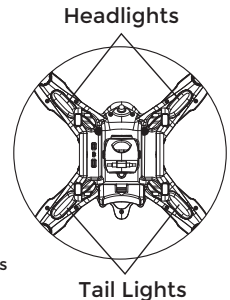
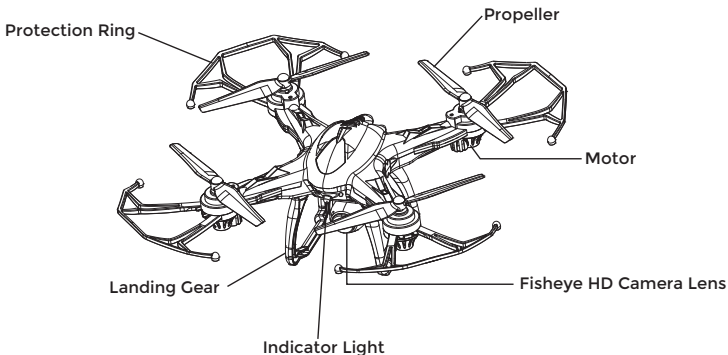

Remote Controller

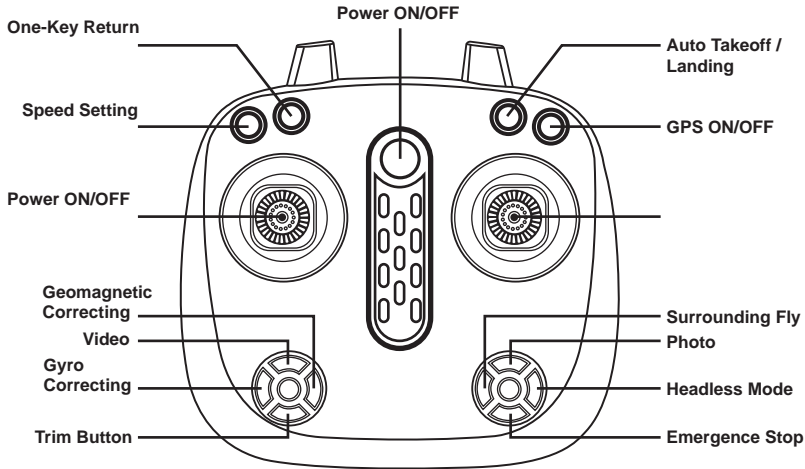

Important Safety Precautions

When using your VTI 360 SKYVIEW 2 GPS VIDEO DRONE, basic safety precautions should always be followed, including the following:

1. Do not allow children or the infirm to operate your drone without adult supervision. For safety purposes, only allow experienced pilots aged 14 and up fly your drone.
2. To avoid choking hazards, keep all small parts and pieces away from children.
3. Your drone is not a toy. Make sure that it is properly assembled before use, and operated safely.
4. Keep your drone away from obstacles, crowds, power lines, trees, and bodies of water while it is in flight. Always fly your drone in a wide open spacious environment. Avoid flying your drone directly above people or animals. Maintain a 7ft (2m) distance from the aircraft when taking off and landing.
5. Only use your drone in a dry environment. Your drone is composed of sophisticated electronic components and parts. To avoid damage to your drone, please keep your drone away from water and moisture. Use a soft dry cloth to wipe the surface of your drone and keep it clean.
6. Beginner and novice level pilots should practice flying with experienced pilots until suitably experienced in flight.
7. To ensure safety, only use the included parts when using your drones.
8. Make sure to keep your ears and eyes protected when using your drone. When your drone's blades are spinning, make sure to keep people and objects at a distance from rotating parts.
9. Keep your drone away from excessive heat or flames, especially while charging the battery.
10. Please recycle or dispose of your drone properly based on the laws and rules of your municipality. Contact local recycling facilities and/or the manufacturer of your speaker for further information.



Aircraft

This section introduces functions and features of the VTI 360 SKYVIEW 2 GPS VIDEO DRONE.

Flight Modes

Your VTI 360 SKYVIEW 2 GPS VIDEO DRONE has 2 flight modes.
GPS Mode: When the aircraft is turned on, it automatically goes into GPS mode.

Normal Flying Mode: Press and hold the GPS/Normal Flying Mode button to switch to Normal Flying Mode.

Aircraft Status Indicator

- 1 Turn on Aircraft > What is the light status?
- 2 Aircraft and Remote Connection > What is the light status?
- 3 Start Compass Calibration> What is the light status?
- 4 Finish Compass Calibration > What is the light status?
- 5 Search GPS Signal > What is the light status?
- 6 Return To Home > What is the light status?
- 7 Return to Home with Low Battery > What is the light status?
- 8 Headless Mode > What is the light status?
- 9 Lose Control > What is the light status?

Return to Home (RTH)

The Return-to-Home (RTH) function brings the aircraft back to the last recorded Home Point.

There are 3 types of RTH: Smart RTH, Low Battery RTH and Failsafe RTH. This section describes these 3 scenarios in detail.

Smart RTH

When the GPS signal is available (more than 7 satellites is presented), use the RTH button on the Remote Controller and then follow the on-screen instructions to initiate Smart RTH.

Smart Return Function

The Smart Return Function returns your drone to the location of your remote control or phone. Push the one key return button on your remote control, or the corresponding button in the VTI 360 SKYVIEW 2 to enter Smart Return mode.

When in Smart Return mode, you can use the directional control stick to control the drone's landing point. Push the throttle stick to exit Smart Return mode.

One-Key Return

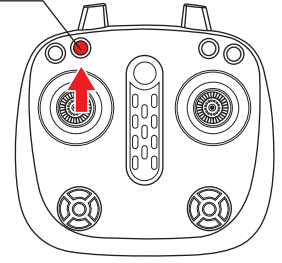

Low Battery RTH

When the battery level of your aircraft is low, it automatically returns directly to the take-off point. During the state of low battery, the aircraft cannot be controlled beyond 20 meters. If the aircraft is returned to within 20 meters from the take-off point, it can be controlled. If it is beyond 20 meters, the aircraft then enters into the landing protection mode in which it performs as follows – because it will not be able to fly more than 20 meters and will not be able to automatically return, it will safely land immediately when the battery is totally depleted.

Failsafe RTH

If the Home Point was successfully recorded and the compass is functioning normally, Failsafe RTH will be automatically activated if the Remote Controller signal is lost for over 6 seconds. Return-to-Home can be cancelled by the pilot, allowing you to regain control when the Remote Controller signal connection is re-established.

Aircraft Power Switch

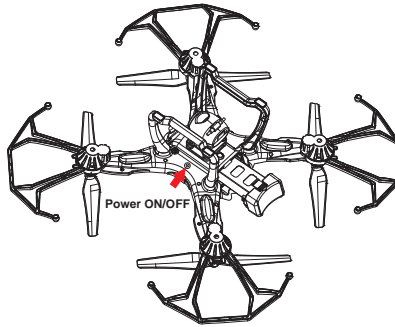

Turn On the Aircraft

Make sure the battery is inserted securely. Then press and hold the power button, located on the bottom of side of the aircraft, for 3 seconds.

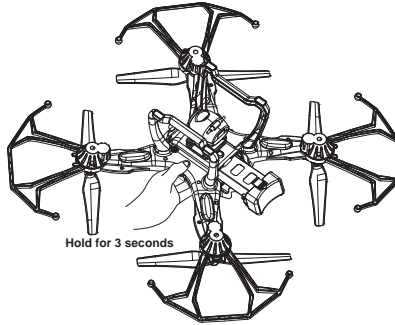

Turn Off the Aircraft

Press the power button to turn off the aircraft. The aircraft's light goes off and the aircraft will then power off.

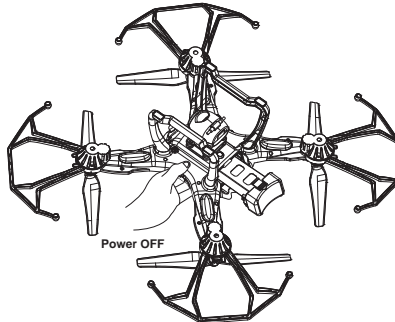

Aircraft Battery

It is made by polymer lithium ion. It has standard battery capacity of 7.4V 2500mAh.

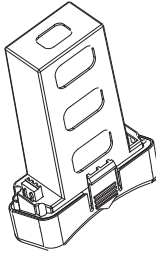

Charging the Battery

- The aircraft's battery needs to be fully charged before every flight.
- Please use the included charging adapter to charge the aircraft's battery.
- The battery takes approx 300-360 minutes to charge fully.

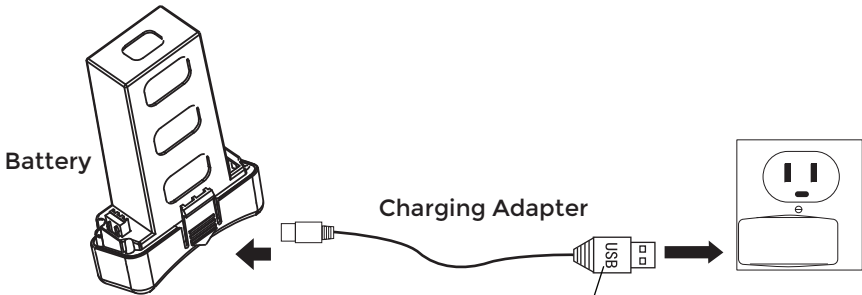







- (red) = Charging Adapter Plugged In
- (blinking green) = Battery Charging
- (solid green) = Battery Fully Charged

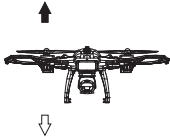

- It is recommended to use a 5V, 1-2A charger (not included) to charge your battery.
- Do not leave the charger unattended in the presence of children.
- Do not expose the battery to excessive heat or flames.
- While charging your battery, keep it away from flammable materials.

Flight

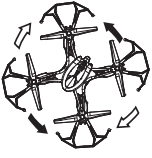
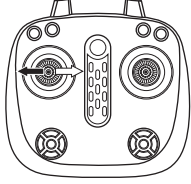
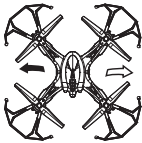
This section reviews safe flight requirements and basic aircraft operations.

Ascend & Descend	<p>Push the throttle stick upwards and the drone will ascend.</p> <p>Pull the throttle stick downwards and the drone will descend.</p>		
Forward & Backward	<p>Push the directional control stick upwards and the drone will tilt downwards, causing it to move forward. Push the directional control stick downwards and the drone will tilt upwards, causing it to move backwards.</p>		
Turn	<p>Slide the throttle stick to the left to turn the nose of the drone, turning it to the left. Slide the throttle stick to the right and the nose of the drone will turn to the right.</p>		
Slide Left & Slide Right	<p>Slide the directional control stick to the left and the entire body of the drone will slide to the left.</p> <p>Slide the directional control stick to the right and the entire body of the drone will slide to the right.</p>		

Environmental Requirements

1. Please don't fly in areas with extremely high temperatures, snow, strong wind (\geq level 5), rain or fog.
2. Always choose a wide open area for every flight. Tall structures and large metal structures may affect the accuracy of the onboard compass and GPS system.
3. Never fly directly over people or animals.
4. To minimize interference, please do not fly the aircraft in locations near power lines, base stations, electrical substations and broadcasting towers.
5. Aircraft and battery performance is subject to environment factors like temperature. Be very careful when flying over 3200ft above sea level since the performance will be affected.
6. Your aircraft cannot use GPS within polar regions.

Flight Limits and GEO Zones

Abide by all laws and regulations when flying your aircraft. Flight limitations are applied by default to help users operate this product safely and legally. Flight limitations include altitude limits, distance limits and GEO Zones. Altitude limits, distance limits and GEO Zones function concurrently to manage flight safety when operating in GPS Mode.

Pre-flight Checklist

Before flight, make sure that:

1. The aircraft's battery is fully charged and the remote controller's batteries are full.
2. The propellers are installed correctly.
3. The camera lens is clean.

Calibrating Your Aircraft (Preparing for Flight)

To power on your drone, press and hold the ON/OFF switch on the bottom of your drone. To power on your remote control, press the ON/OFF button. Once your drone and remote control are powered on, follow the calibration steps below in order to prepare your drone for flight.

Calibrating Your Drone with Your Remote Control

-Push the throttle stick all the way up and then pull it all the way down.

-When the LED lights on the rear legs of your drone are solid red and the LED lights on the front legs of your drone are solid green then your drone is synchronized with your remote control and ready to fly.

-When the LED lights on the rear legs of your drone are blinking red then your drone is in GPS mode

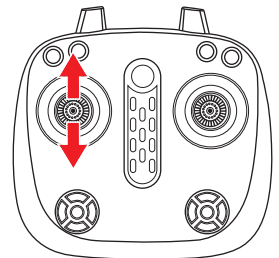

Calibrating Your Drone's Internal Gyroscope

-Calibrate your drone's internal gyroscope to ensure smooth and balanced flight. Before you start, make sure your drone is placed on a flat, stable surface.

-Press the Gyro Correcting button on your remote control, the LED lights of drone start blinking rapidly and then become solid red and green. Your drone's internal gyroscope is calibrated.

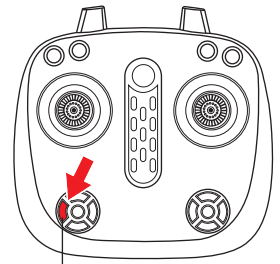

**Gyro
Correcting**

Aircraft Compass Calibration

The aircraft compass calibration allows your drone to be tracked over GPS. Before you start, make sure your drone is placed on a flat, stable surface.

-Press the geomagnetic calibration button on the remote control.

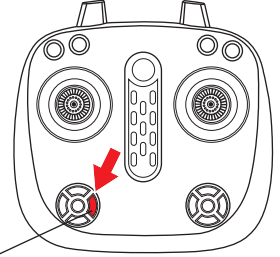

**Geomagnetic
Correcting**

-Rotate your drone horizontally, spinning it in a clockwise direction for 3 revolutions. The lights on the front legs of your drone will solidly shine red, while the lights on the back legs of your drone will solidly shine green.

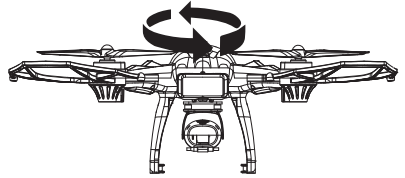

-Turn the head downwards and rotate your drone vertically, spinning it for 3 revolutions. When you see green lights shining solidly, calibration is complete.

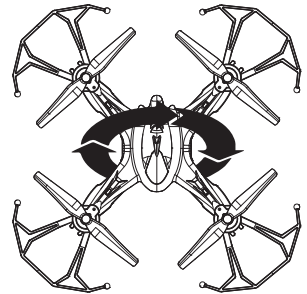

- When flying your drone in GPS mode, make sure you are in a wide open space.
- Do not calibrate your drone in areas where there are strong magnetic fields.
- When calibrating, do not carry ferromagnetic materials such as keys or cell phones.
- Do not calibrate near large sheets of metal.

Locking and Unlocking Your Drone

Unlocking Your Drone

If your drone is locked, push the throttle stick to bottom left and push the right stick to bottom right, your drone will be unlocked.

Notice: When the drone is indoor, you must press and hold the GPS ON/OFF button until heard the sound of "DI", the drone will quit GPS mode, then it can be unlocked.

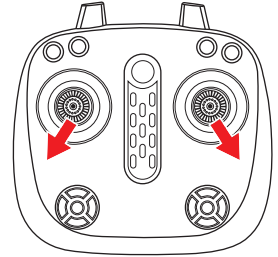

Locking Your Drone

With your drone in a landed position, pull the throttle stick all the way down and hold it down for approximately 3 seconds. The motor will stop and your drone will be locked in place.

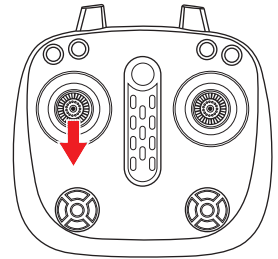

Important Information

The subsections are:

- Important Statement
- Flight Safety Guidelines
- FCC Compliance Statement
- Vivitar 1 Year Warranty

Important Statement

- This aircraft is not a toy. It should be assembled and operated properly. Pilots must operate this aircraft in a safe way. Improper operation may cause injury or property damage.
- This aircraft is suitable for pilots aged 14+ who have experience piloting an aircraft styled aircraft.
- The manufacturer of this product is not responsible for damages caused by misuse.
- Keep small accessories away from children and the infirm to avoid accidents.

Flight Safety Guidelines

Users should firmly uphold the principle of “safety comes first” when flying this aircraft. Never fly the aircraft near airports, above crowds or in zones storing dangerous goods and be mindful of the damage that can be caused by improper operation.

- Stay away from obstacles, crowds, power lines, trees or water.

Always choose a wide open area for every flight, well away from people and property. Never fly directly over people or animals. Don't fly in bad weather conditions, high temperature, snow, strong wind (\geq level 5), rain or fog. Maintain

a 7ft (2m) distance from the aircraft when taking off and landing.

- Keep the aircraft in a dry environment.

The aircraft is composed by sophisticated electronic components and mechanical parts. To avoid damage of the mechanical and electronic components, please keep the aircraft in a dry environment and use a clean, soft cloth to

wipe the surface and keep it clean.

- Practice flying together with a skilled, experienced pilot. Beginners are recommended to practice flying with a skilled pilot's guidance. Do not fly alone.

● Keep proper operation and safe flight guidelines in mind. Please take a careful look at this manual before flying for important information regarding the product's functions and operating tips. Stay informed of and abide strictly by relevant local laws and regulations. Keep away from any non-flight zones and respect other people's privacy.

- Safe flying

Please make sure you are in good shape mentally before every flight. Fly the aircraft as per your flying experience. Never fly under influence of alcohol or drugs.

- Keep distance from a flying aircraft.

Never use your hands to touch a flying aircraft under any circumstance. Don't approach and touch a landed aircraft before its propellers are completely locked.

- Keep away from heat sources

This aircraft is made of metal, fiber, plastic, electronic components and other materials. Please keep it away from heat sources to avoid deformation or even damage caused by sun exposure and high temperature.

- Environmental protection requirements

To protect our lovely planet, please recycle this aircraft as per local laws and regulations.

Keep the Remote Controller at least 20 cm away from your body when flying the aircraft

FCC Compliance Statement

Changes or modifications not expressly approved by the party responsible for compliance could void the user's authority to operate the equipment.

This device complies with Part 15 of the FCC Rules. Operation is subject to the following two conditions: (1) this device may not cause harmful interference, and (2) this device must accept any interference received, including interference that may cause undesired operation.

This equipment has been tested and found to comply with the limits for a Class B digital device, pursuant to Part 15 of the FCC Rules. These limits are designed to provide reasonable protection against harmful interference in a residential installation. This equipment generates, uses and can radiate radio frequency energy and, if not installed and used in accordance with the instructions, may cause harmful interference to radio communications. However, there is no guarantee that interference will not occur in a particular installation.

If this equipment does cause harmful interference to radio or television reception, which can be determined by turning the equipment off and on, the user is encouraged to try to correct the interference by one or more of the following measures:

- Reorient or relocate the receiving antenna.
- Increase the separation between the equipment and receiver.
- Connect the equipment into an outlet on a circuit different from that to which the receiver is connected.
- Consult the dealer or an experienced radio/TV technician for help.

Vivitar 1 Year Warranty

This warranty covers the original consumer purchaser only and is not transferable.

This warranty covers products that fail to function properly UNDER NORMAL USAGE, due to defects in material or workmanship. Your product will be repaired or replaced at no charge for parts or labor for a period of one year.

What Is Not Covered by Warranty

Damages or malfunctions not resulting from defects in material or workmanship and damages or malfunctions from other than normal use, including but limited to, repair by unauthorized parties, tampering, modification or accident.

To Obtain Warranty Service and Troubleshooting Information:

Call 1-800-592-9541 in the U.S. or visit our website at www.vivitar.com.

Sakar International Inc

195 Carter Drive Edison, NJ, 08817, USA

To receive Warranty service along with the name and address of an authorized product service center, the original consumer purchaser must contact us for problem determination and service procedures.

Proof of purchase in the form of a bill of sale or receipted invoice, evidencing that the product is within the applicable Warranty period(s), MUST be presented in order to obtain the requested service. It is your responsibility to properly package and send any defective products along with a dated copy of proof of purchase, a written explanation of the problem, and a valid return address to the authorized service center at your expense. Do not include any other items or accessories with the defective product. Any products received by the authorized service center that are not covered by warranty will be returned unpaired.

Vivitar One Year Warranty

This warranty covers the original consumer purchaser only and is not transferable.

This warranty covers products that fail to function properly UNDER NORMAL USAGE, due to defects in material or workmanship. Your product will be repaired or replaced at no charge for parts or labor for a period of one year.

What Is Not Covered by Warranty

Damages or malfunctions not resulting from defects in material or workmanship and damages or malfunctions from other than normal use, including but limited to, repair by unauthorized parties, tampering, modification or accident.

To Obtain Warranty Service and Troubleshooting Information:

Call 1-800-592-9541 in the U.S. or visit our website at www.vivitar.com.

To receive Warranty service along with the name and address of an authorized product service center, the original consumer purchaser must contact us for problem determination and service procedures. Proof of purchase in the form of a bill of sale or receipted invoice, evidencing that the product is within the applicable Warranty period(s), MUST be presented in order to obtain the requested service. It is your responsibility to properly package and send any defective products along with a dated copy of proof of purchase, a written explanation of the problem, and a valid return address to the authorized service center at your expense. Do not include any other items or accessories with the defective product. Any products received by the authorized service center that are not covered by warranty will be returned unrepared.