

保密等级：机密

## SPECIFICATION

### 产品规格书

## EL.MT7668BUN-WF

**IEEE 802.11b/g/n/a/ac 2T2R USB WiFi Module**

**Integrated BT 2.1+EDR/4.2/5.0**

<b>Approved by Shikun</b>		
Checked by 审核	Rechecked by 复审	Approved by 批准

Please send the original back to us after you have approved and signed.

客户承认签章后敬请寄回正本一份。

<b>Approved by customer</b>		
Comments 确认意见	Approved by 批准签字	Company's seal 盖章
Customer's Name:		

## REVISION HISTORY

VERSION	DATE	BOARD ID	PAGE	DESCRIPTION	AUTHOR
V0	2021.03.06	EL.MT7668BUN-WF	All	First Issued	Sannis
V1.0	2021.07.30	EL.MT7668BUN-WF	All	Add package and dimensional tolerance	Sannis
V1.1	2021.08.27	EL.MT7668BUN-WF	4	Update product pictures	Zhouz

# Content

1. Introduction (简介) .....	1
2. Features (特性) .....	1
3. Block Diagram (结构框图) .....	2
4. Package Outline and Mounting (外形及安装尺寸) .....	2
5. Product Pictures (实物图片) .....	4
6. Key Materials (关键物料) .....	5
7. General Requirements (一般要求) .....	5
8. Electrical Characteristics (电气特性) .....	5
8.1 IEEE 802.11b Section.....	5
8.2 IEEE 802.11g Section.....	6
8.3 IEEE 802.11n HT20 Section.....	7
8.4 IEEE 802.11n HT40 Section.....	8
8.5 IEEE 802.11a Section.....	9
8.6 IEEE 802.11n HT20 Section(5GHz).....	9
8.7 IEEE 802.11n HT40 Section(5GHz).....	10
8.8 IEEE 802.11ac Section(5GHz).....	11
8.9 Bluetooth Section.....	12
9. Mechanical,Environmental and Reliability Tests (机械、环境和可靠性测试)	13
10. Package (包装) .....	16

## 1. Introduction (简介)

EL.MT7668BUN-WF module is based on MediaTek MT7668BUN solution. MT7668BUN is a highly integrated single chip which features a low power 2x2 802.11b/g/n Wi-Fi subsystem and a Bluetooth subsystem. The Wi-Fi subsystem contains the 802.11 a/b/g/n/ac radio, baseband, and MAC that are designed to meet both the low power and high throughput application. The Bluetooth subsystem contains the Bluetooth radio which complies with Bluetooth v2.1+EDR, v4.2, and v5.0, baseband, link controller. This documentation describes the engineering requirements specification.

EL.MT7668BUN-WF 模块基于 MEDIATEK MT7668BUN 解决方案。MT7668BUN 是一款高度集成的芯片，具有低功耗 2x2 802.11 a/b/g/n/ac Wi-Fi 子系统和蓝牙子系统。Wi-Fi 子系统包含 802.11b/g/n 射频、基带和 MAC，旨在满足低功耗和高吞吐量应用。蓝牙子系统包含蓝牙 2.1+EDR、v4.2 和 v5.0、基带和链路控制器。本文件描述了工程需求规范。

## 2. Features (特性)

<b>Reserving System</b> 接收制式	IEEE Std. 802.11a
	IEEE Std. 802.11b
	IEEE Std. 802.11g
	IEEE Std. 802.11n
	IEEE Std. 802.11ac
	BT 2.1+EDR
	BT 4.2
	BT 5.0
<b>Chip Solution</b> 芯片方案	MT7668BUN
<b>Band 波段</b>	2.4GHz/5GHz
<b>Dimensions</b> 尺寸	30mm×25mm×2.8mm

<b>Model</b> 型号	<b>Installation Mode</b> 安装方式	<b>Protocol I</b> 支持标准	<b>Frequency</b> 频段	<b>Antenna</b> 天线	<b>Remark</b> 备注
EL.MT7668BU N-WF	SMD	IEEE 802.11a/b/g/n/ac BT 2.1+EDR/4.2/5.0	2.4GHz/5GHz	IPEX	30mm×25mm× 2.8mm

### 3. Block Diagram (结构框图)

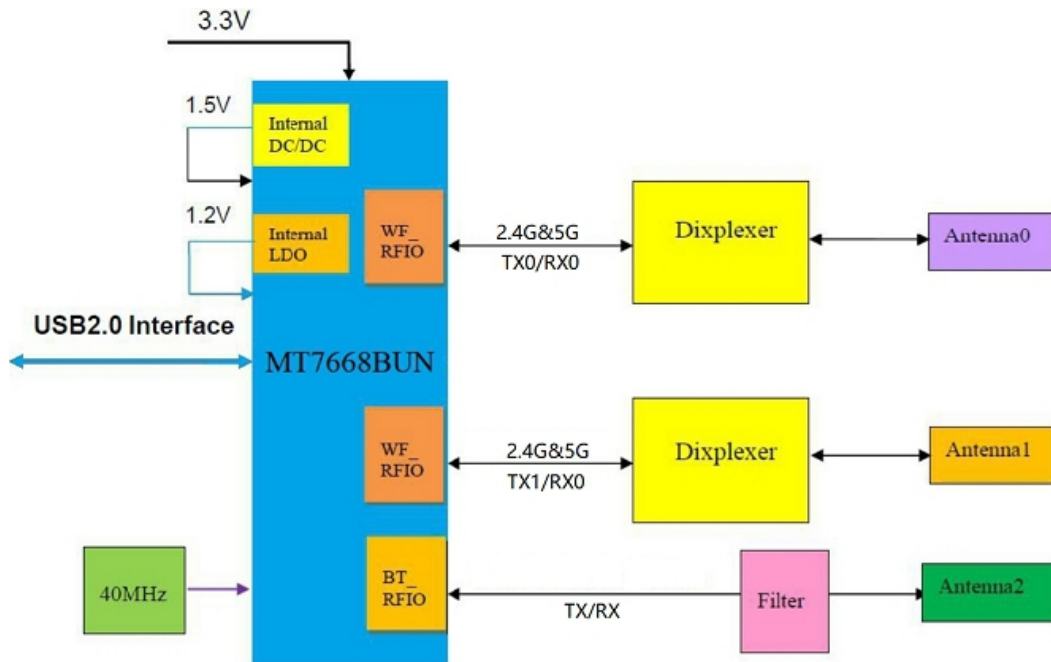
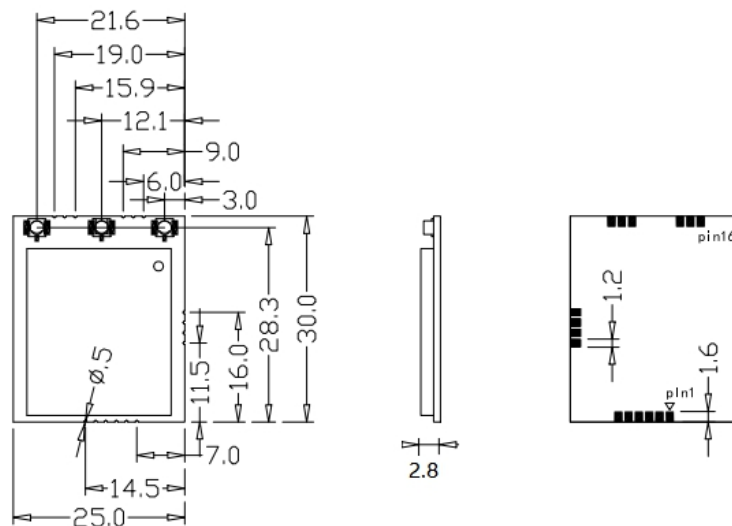

Figure 1 EL.MT7668BUN-WF Block Diagram

### 4. Package Outline and Mounting (外形及安装尺寸)



PCB Tolerance	PCB size	±0.15mm	
	PCB thickness	≤1.0mm	±0.1mm
		>1.0mm	±10%
Connector Tolerance	Material size	±0.2mm	
	SMT floating high	+0.15/-0mm	
	DIP floating high	+0.3/-0mm	

**Pin Definition (引脚定义)**

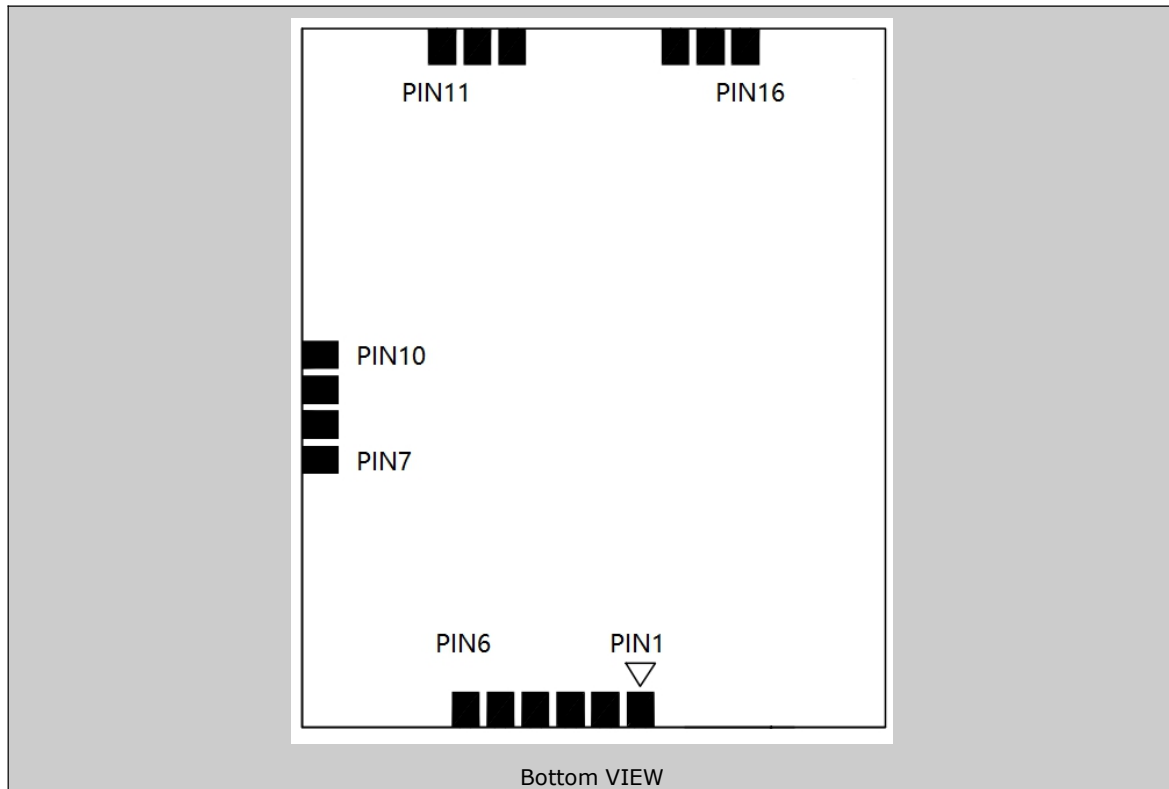

PIN	SYMBOL	DESCRIPTION
1	WOW	内部有 10K 上拉电阻, 低电平有效
2	RESET	内部有 10K 上拉电阻, 低电平有效
3	3V3	3.3V
4	DM	USB_DM
5	DP	USB_DP
8	BT_SYNC	Glass sync,内部有 10K 上拉电阻
9	BT_HOST_WAKE	内部有 10K 上拉电阻, 低电平有效
6,7,10,11,13,14,16	GND	GND
12,15	NC	NC

## 5. Product Pictures (实物图片)



正视图 (top view)



背视图 (bottom view)

丝印说明:

- (1) 正视图内标签处红色方框内的字符为产品型号, 如图, 本机型为 EL.MT7668BUN-WF;
- (2) 背视图内黄色方框处的字符为产品周期号;



标签信息 (information view)

## 6. Key Materials (关键物料)

序号	关键件名称	型号	规格/材料	备注
1	集成电路	MT7668BUN	76-QFN	
2	PCB	SKI.WB668U.9	FR-4,4LAY	
3	晶体振荡器	CF4040M00015T2115142	40MHz	

## 7. General Requirements (一般要求)

No.	Feature	Description
7-1	Operation Voltage 工作电压范围	3.3V+/-0.3
7-2	Current Consumption 最大电流	700mA
7-3	Ripple 纹波	≤100mV
7-4	Operation Temperature 工作温度范围	0°C to +40°C
7-5	Antenna Type 天线类型	External antenna
7-6	USB	High Speed USB 2.0 Interface
7-7	Storage Temperature 存储温度	-40°C to +125°C

## 8. Electrical Characteristics (电气特性)

除非另有说明，电气规范试验都在下列条件下进行：

环境条件温度：25°C ± 5°C；

电源电压：模块输入电压 3.3V+/-0.3；

The Test for electrical specification was performed under the following condition unless otherwise specified:

Ambient condition Temperature :25°C ± 5°C；

Power supply voltages: 3.3V+/-0.3 input power at the Module；

### 8.1 IEEE 802.11b Section

Items	Contents				
Specification	IEEE802.11b				
Mode	CCK				
Channel	CH1 to CH13				
Data rate	1, 2, 5.5, 11Mbps				
TX Characteristics	Min.	Typ.	Max.	Unit	Remark
1. Power Levels(Calibrated)					
1) For antenna port	15	17	19	dBm	
2. Spectrum Mask @ target power					
1) fc +/-11MHz to +/-22MHz	-	-	-30	dBr	



2) $f_c > \pm 22\text{MHz}$	-	-	-50	dBr	
3 Constellation Error(EVM)@ target power					
1) 1Mbps	-	-	-10	dB	
2) 2Mbps	-	-	-10	dB	
3) 5.5Mbps	-	-	-10	dB	
4) 11Mbps	-	-	-10	dB	
4. Frequency Error	-20	-	20	ppm	
RX Characteristics	Min.	Typ.	Max.	Unit	
5 Minimum Input Level Sensitivity (each chain)					
1) 1Mbps (FER $\leq 8\%$ )	-	-	-83	dBm	
2) 2Mbps (FER $\leq 8\%$ )	-	-	-80	dBm	
3) 5.5Mbps (FER $\leq 8\%$ )	-	-	-79	dBm	
4) 11Mbps (FER $\leq 8\%$ )	-	-	-76	dBm	
6 Maximum Input Level (FER $\leq 8\%$ )	-10	-	-	dBm	

## 8.2 IEEE 802.11g Section

Items	Contents				
Specification	IEEE802.11g				
Mode	OFDM				
Channel	CH1 to CH13				
Data rate	6, 9, 12, 18, 24, 36, 48, 54Mbps				
TX Characteristics	Min.	Typ.	Max.	Unit	Remark
1. Power Levels					
1) For antenna port	13	15	17	dBm	
2. Spectrum Mask @ target power					
1) at $f_c \pm 11\text{MHz}$	-	-	-20	dBr	
2) at $f_c \pm 20\text{MHz}$	-	-	-28	dBr	
3) at $f_c > \pm 30\text{MHz}$	-	-	-40	dBr	
3 Constellation Error(EVM)@ target power					
1) 6Mbps	-	-	-5	dB	
2) 9Mbps	-	-	-8	dB	
3) 12Mbps	-	-	-10	dB	
4) 18Mbps	-	-	-13	dB	
5) 24Mbps	-	-	-16	dB	
6) 36Mbps	-	-	-19	dB	
7) 48Mbps	-	-	-22	dB	
8) 54Mbps	-	-	-25	dB	
4 Frequency Error	-20	-	20	ppm	
RX Characteristics	Min.	Typ.	Max.	Unit	
5 Minimum Input Level Sensitivity					

(each chain)					
1) 6Mbps (PER $\leq 10\%$ )	-	-	-85	dBm	
2) 9Mbps (PER $\leq 10\%$ )	-	-	-84	dBm	
3) 12Mbps (PER $\leq 10\%$ )	-	-	-82	dBm	
4) 18Mbps (PER $\leq 10\%$ )	-	-	-80	dBm	
5) 24Mbps (PER $\leq 10\%$ )	-	-	-77	dBm	
6) 36Mbps (PER $\leq 10\%$ )	-	-	-73	dBm	
7) 48Mbps (PER $\leq 10\%$ )	-	-	-69	dBm	
8) 54Mbps (PER $\leq 10\%$ )	-	-	-65	dBm	
6 Maximum Input Level (PER $\leq 10\%$ )	-20	-	-	dBm	

### 8.3 IEEE 802.11n HT20 Section

Items	Contents				
Specification	IEEE802.11n HT20 @ 2.4GHz				
Mode	OFDM				
Channel	CH1 to CH13				
Data rate (MCS index)	MCS0/1/2/3/4/5/6/7				
TX Characteristics	Min.	Typ.	Max.	Unit	
1. Power Levels					
1) For antenna port	12	14	16	dBm	
2. Spectrum Mask @ target power					
1) at fc +/-11MHz	-	-	-20	dBr	
2) at fc +/-20MHz	-	-	-28	dBr	
3) at fc > +/-30MHz	-	-	-45	dBr	
3. Constellation Error(EVM)@ target power					
1) MCS0	-	-	-5	dB	
2) MCS1	-	-	-10	dB	
3) MCS2	-	-	-13	dB	
4) MCS3	-	-	-16	dB	
5) MCS4	-	-	-19	dB	
6) MCS5	-	-	-22	dB	
7) MCS6	-	-	-25	dB	
8) MCS7	-	-	-28	dB	
4. Frequency Error	-20	-	20	ppm	
RX Characteristics	Min.	Typ.	Max.	Unit	
5. Minimum Input Level Sensitivity (each chain)					
1) MCS0 (PER $\leq 10\%$ )	-	-	-82	dBm	
2) MCS1 (PER $\leq 10\%$ )	-	-	-79	dBm	
3) MCS2 (PER $\leq 10\%$ )	-	-	-77	dBm	
4) MCS3 (PER $\leq 10\%$ )	-	-	-74	dBm	

5) MCS4 (PER $\leq 10\%$ )	-	-	-70	dBm	
6) MCS5 (PER $\leq 10\%$ )	-	-	-66	dBm	
7) MCS6 (PER $\leq 10\%$ )	-	-	-65	dBm	
8) MCS7 (PER $\leq 10\%$ )	-	-	-64	dBm	
7. Maximum Input Level (PER $\leq 10\%$ )	-20	-	-	dBm	

## 8.4 IEEE 802.11n HT40 Section

Items	Contents				
Specification	IEEE802.11n HT40 @ 2.4GHz				
Mode	OFDM				
Channel	CH3 to CH11				
Data rate (MCS index)	MCS0/1/2/3/4/5/6/7				
TX Characteristics	Min.	Typ.	Max.	Unit	
1. Power Levels (Calibrated)					
1) For antenna port	11	13	15	dBm	
2. Spectrum Mask @target power					
1) at fc +/-22MHz	-	-	-20	dBr	
2) at fc +/-40MHz	-	-	-28	dBr	
3) at fc > +/-60MHz	-	-	-45	dBr	
3. Constellation Error(EVM)@ target power					
1) MCS0	-	-	-5	dB	
2) MCS1	-	-	-10	dB	
3) MCS2	-	-	-13	dB	
4) MCS3	-	-	-16	dB	
5) MCS4	-	-	-19	dB	
6) MCS5	-	-	-22	dB	
7) MCS6	-	-	-25	dB	
8) MCS7	-	-	-28	dB	
4. Frequency Error	-20	-	20	ppm	
RX Characteristics	Min.	Typ.	Max.	Unit	
5. Minimum Input Level Sensitivity (each chain)					
1) MCS0 (PER $\leq 10\%$ )	-	-	-79	dBm	
2) MCS1 (PER $\leq 10\%$ )	-	-	-76	dBm	
3) MCS2 (PER $\leq 10\%$ )	-	-	-74	dBm	
4) MCS3 (PER $\leq 10\%$ )	-	-	-71	dBm	
5) MCS4 (PER $\leq 10\%$ )	-	-	-67	dBm	
6) MCS5 (PER $\leq 10\%$ )	-	-	-63	dBm	
7) MCS6 (PER $\leq 10\%$ )	-	-	-62	dBm	
8) MCS7 (PER $\leq 10\%$ )	-	-	-61	dBm	
6. Maximum Input Level (PER $\leq 10\%$ )	-20	-	-	dBm	

## 8.5 IEEE 802.11a Section

Items	Contents				
Specification	IEEE802.11a				
Mode	OFDM				
Channel	CH36 to CH165				
Data rate (MCS index)	6, 9, 12, 18, 24, 36, 48, 54Mbps				
TX Characteristics	Min.	Typ.	Max.	Unit	
1. Power Levels (Calibrated)					
1) For antenna port	13	15	17	dBm	
2. Spectrum Mask @target power					
1) at fc +/-11MHz	-	-	-20	dBr	
2) at fc +/-20MHz	-	-	-28	dBr	
3) at fc > +/-30MHz	-	-	-40	dBr	
3. Constellation Error(EVM)@ target power					
1) 6Mbps	-	-	-5	dB	
2) 9Mbps	-	-	-8	dB	
3) 12Mbps	-	-	-10	dB	
4) 18Mbps	-	-	-13	dB	
5) 24Mbps	-	-	-16	dB	
6) 36Mbps	-	-	-19	dB	
7) 48Mbps	-	-	-22	dB	
8) 54Mbps	-	-	-25	dB	
4 Frequency Error	-20	-	20	ppm	
RX Characteristics	Min.	Typ.	Max.	Unit	
5 Minimum Input Level Sensitivity (each chain)					
1) 6Mbps (PER ≤10%)	-	-	-82	dBm	
2) 9Mbps (PER ≤10%)	-	-	-81	dBm	
3) 12Mbps (PER ≤10%)	-	-	-79	dBm	
4) 18Mbps (PER ≤10%)	-	-	-77	dBm	
5) 24Mbps (PER ≤10%)	-	-	-74	dBm	
6) 36Mbps (PER ≤10%)	-	-	-70	dBm	
7) 48Mbps (PER ≤10%)	-	-	-66	dBm	
8) 54Mbps (PER ≤10%)	-	-	-65	dBm	
6. Maximum Input Level (PER ≤10%)	-30	-	-	dBm	

## 8.6 IEEE 802.11n HT20 Section(5GHz)

Items	Contents
Specification	IEEE802.11n HT20 @ 5GHz

Mode	BPSK, QPSK, 16QAM, 64QAM and OFDM				
Channel	CH36 to CH165				
Data rate (MCS index)	MCS0/1/2/3/4/5/6/7				
TX Characteristics	Min.	Typ.	Max.	Unit	
1. Power Levels (Calibrated)					
1) For antenna port	12	14	16	dBm	
2. Spectrum Mask @target power					
1) at fc +/-11MHz	-	-	-20	dB	
2) at fc +/-20MHz	-	-	-28	dB	
3) at fc > +/-30MHz	-	-	-45	dB	
3. Constellation Error(EVM)@ target power					
1) MCS0	-	-	-5	dB	
2) MCS1	-	-	-10	dB	
3) MCS2	-	-	-13	dB	
4) MCS3	-	-	-16	dB	
5) MCS4	-	-	-19	dB	
6) MCS5	-	-	-22	dB	
7) MCS6	-	-	-25	dB	
8) MCS7	-	-	-28	dB	
4. Frequency Error	-20	-	20	ppm	
RX Characteristics	Min.	Typ.	Max.	Unit	
6. Minimum Input Level Sensitivity (each chain)					
1) MCS0 (PER $\leq$ 10%)	-	-	-82	dBm	
2) MCS1 (PER $\leq$ 10%)	-	-	-79	dBm	
3) MCS2 (PER $\leq$ 10%)	-	-	-77	dBm	
4) MCS3 (PER $\leq$ 10%)	-	-	-74	dBm	
5) MCS4 (PER $\leq$ 10%)	-	-	-70	dBm	
6) MCS5 (PER $\leq$ 10%)	-	-	-66	dBm	
7) MCS6 (PER $\leq$ 10%)	-	-	-65	dBm	
8) MCS7 (PER $\leq$ 10%)	-	-	-64	dBm	
6. Maximum Input Level (PER $\leq$ 10%)	-30	-	-	dBm	

## 8.7 IEEE 802.11n HT40 Section(5GHz)

Items	Contents				
Specification	IEEE802.11n HT40 @ 5GHz				
Mode	BPSK, QPSK, 16QAM, 64QAM and OFDM				
Channel	CH38 to CH163				
Data rate (MCS index)	MCS0/1/2/3/4/5/6/7				
TX Characteristics	Min.	Typ.	Max.	Unit	
1. Power Levels (Calibrated)					

1) For antenna port	11	13	15	dBm	
2. Spectrum Mask @target power					
1) at fc +/-21MHz	-	-	-20	dBr	
2) at fc +/-40MHz	-	-	-28	dBr	
3) at fc > +/-60MHz	-	-	-45	dBr	
3. Constellation Error(EVM)@ target power					
1) MCS0	-	-	-5	dB	
2) MCS1	-	-	-10	dB	
3) MCS2	-	-	-13	dB	
4) MCS3	-	-	-16	dB	
5) MCS4	-	-	-19	dB	
6) MCS5	-	-	-22	dB	
7) MCS6	-	-	-25	dB	
8) MCS7	-	-	-28	dB	
4. Frequency Error	-20	-	20	ppm	
RX Characteristics	Min.	Typ.	Max.	Unit	
7. Minimum Input Level Sensitivity (each chain)					
1) MCS0 (PER $\leq$ 10%)	-	-	-79	dBm	
2) MCS1 (PER $\leq$ 10%)	-	-	-76	dBm	
3) MCS2 (PER $\leq$ 10%)	-	-	-74	dBm	
4) MCS3 (PER $\leq$ 10%)	-	-	-71	dBm	
5) MCS4 (PER $\leq$ 10%)	-	-	-67	dBm	
6) MCS5 (PER $\leq$ 10%)	-	-	-63	dBm	
7) MCS6 (PER $\leq$ 10%)	-	-	-62	dBm	
8) MCS7 (PER $\leq$ 10%)	-	-	-61	dBm	
6. Maximum Input Level (PER $\leq$ 10%)	-30	-	-	dBm	

## 8.8 IEEE 802.11ac Section(5GHz)

Items	Contents				
Specification	IEEE802.11ac				
Mode	BPSK, QPSK, 16QAM, 64QAM, 256QAM and OFDM				
Channel	CH36 to CH165 VHT20 CH38 to CH163 VHT40 CH42 to CH157 VHT80				
Data rate (MCS index)	MCS0/1/2/3/4/5/6/7/8/9				
	Min.	Typ.	Max.	Unit	Remark
TX Characteristics	Min.	Typ.	Max.	Unit	
1. Power Levels (Calibrated)					
1) For antenna port	11	13	15	dBm	

2. Spectrum Mask @VHT20/VHT40/VHT80 target power						
1) at fc +/-11MHz/21MHz/41MHz	-	-	-20		dBr	
2) at fc +/-20MHz/40MHz/80MHz	-	-	-28		dBr	
3) at fc +/-30MHz/60MHz/120MHz	-	-	-40		dBr	
3. Constellation Error(EVM)@ target power						
1) MCS0	-	-	-5		dB	
2) MCS1	-	-	-10		dB	
3) MCS2	-	-	-13		dB	
4) MCS3	-	-	-16		dB	
5) MCS4	-	-	-19		dB	
6) MCS5	-	-	-22		dB	
7) MCS6	-	-	-25		dB	
8) MCS7	-	-	-27		dB	
9) MCS8	-	-	-30		dB	
10) MCS9	-	-	-32		dB	
4. Frequency Error	-20	-	20		ppm	
RX Characteristics	Min.	Typ.	Max.		Unit	
5. Minimum Input Level Sensitivity (each chain)			VHT 20	VHT 40	VHT 80	
1) MCS0 (PER $\leq 10\%$ )	-	-	-82	-79	-76	dBm
2) MCS1 (PER $\leq 10\%$ )	-	-	-79	-76	-73	dBm
3) MCS2 (PER $\leq 10\%$ )	-	-	-77	-74	-71	dBm
4) MCS3 (PER $\leq 10\%$ )	-	-	-74	-71	-68	dBm
5) MCS4 (PER $\leq 10\%$ )	-	-	-70	-67	-64	dBm
6) MCS5 (PER $\leq 10\%$ )	-	-	-66	-63	-60	dBm
7) MCS6 (PER $\leq 10\%$ )	-	-	-65	-62	-59	dBm
8) MCS7 (PER $\leq 10\%$ )	-	-	-64	-61	-58	dBm
9) MCS8 (PER $\leq 10\%$ )	-	-	-59	-56	-53	dBm
10) MCS9 (PER $\leq 10\%$ )	-	-	-57	-54	-51	dBm
6. Maximum Input Level (PER $\leq 10\%$ )	-30	-	-			dBm

## 8.9 Bluetooth Section

Items	Contents				
Specification	BT2.1+EDR/4.2/5.0				
Mode	FHSS,GFSK,DPSK,DQPSK				
Number of Channel	79 Channels				
Frequency Band	2.402 GHz ~2.480GHz				
	Min.	Typ.	Max.	Unit	Remark
1. Output Power		4	-	dBm	
2. Gain step	2	4	8	dB	

3. Receiver sensitivity (BER $\leq$ 0.1%)	-	-93.5	-80	dBm	
4. Maximum usable signal (BER $\leq$ 0.1%)	-	-5	-		
5. C/I co-channel (BER<0.1%)	-	4	11	dB	
6. C/I 1MHz (BER<0.1%)	-	-14	0	dB	
7. C/I 2MHz (BER<0.1%)	-	-42	-30	dB	
8. C/I $\geq$ 3MHz (BER<0.1%)	-	-49	-40	dB	
9. C/I Image channel (BER<0.1%)	-	-25	-9	dB	
10. C/I Image 1MHz (BER<0.1%)	-	-50	-20	dB	
11. Inter-modulation	-	-13	-	dB	
12. Out-of-band blocking					
1). 30MHz to 2000MHz	-10	-	-	dBm	
2). 2000MHz to 2399MHz	-27	-	-	dBm	
3). 2498MHz to 3000MHz	-27	-	-	dBm	
4). 3000MHz to 12.75GHz	-10	-	-	dBm	
13. Modulation characteristics					
1). $\Delta f_{1avg}$	140	157	175	KHz	
2). $\Delta f_{2max}$ (For at least 99.9% of all $\Delta f_{2max}$ )	115	140	-	KHz	
3). $\Delta f_{1avg} / \Delta f_{2avg}$	0.8	0.98	-	KHz	
14. ICFT	-75	$\pm 20$	+75	KHz	
15. Carrier frequency drift					
1). One slot packet (DH1)	-25	$\pm 15$	+25	KHz	
2). Two slot packet (DH3)	-40	$\pm 15$	+40	KHz	
3). Five slot packet (DH5)	-40	$\pm 15$	+40	KHz	
4). Max drift rate	-	6	20	KHz/50us	
16. TX output spectrum(20dB bandwidth)	-	922	1000	KHz	
17. In-Band spurious emission					
1). $\pm 2$ MHz offset	-	-45	-20	dBm	
2). $\pm 3$ MHz offset	-	-48	-40	dBm	
3). $> \pm 3$ MHz offset	-	-48	-40	dBm	

## 9. Mechanical, Environmental and Reliability Tests

### (机械、环境和可靠性测试)

Test Items		Test Conditions	Qty	Criteria Condition
9-1	Drop test	The packed samples was tested at below condition: Drop height: 760mm(0.5~9.5kg) 610mm(9.5~18.5kg) Drop time: 1x corner, 3x edge and 6x face.	1xBox	After test, the outer box and inner box will not be broken by appearance visual inspection, and the products should be ok.



9-2	<b>Vibration test</b>	X-Y-Z direction, first Frequency changing from 10Hz to 30Hz to 10Hz, amplitude 2.0mm, 5 times vibrations, 5x times vibration.	1xBox	After test, the outer box and inner box will not be broken by appearance visual inspection and the products should be ok.
9-3	<b>Soldering ability test (Only for SKI module)</b>	Soldering temperature: 245±5℃ Soldering duration: 3±0.5S	3	1. After soldering, the soldered area must be covered by a smooth bright solder layer, some deficiencies such as a small amount of the pinhole, not wetting are allowed, but the deficiencies can not be in the same place; 2. At least 90% of soldered area shall be covered continuously by the soldering material.
9-4	<b>High Temperature and Humidity Operation Test</b>	Leave samples in 60℃, 90% RH @ 24 hours	4	After test, the products appearance, power, EVM and frequency error functional parameter shall be satisfied with the test specification.
9-5	<b>Low Temperature Operation Test</b>	Leave samples in -15℃ @24 hours	4	After test, the products appearance, power, EVM and frequency error functional parameter shall be satisfied with the test specification.
9-6	<b>High Temperature and Humidity Start Test</b>	Leave samples in 60℃, 90% RH for 4x hours	4	After test, power on and off the samples for 3x tiems, the samples should be able to start normally
9-7	<b>Low temperature start test</b>	Leave samples in -15℃ for 4x hours	4	After test, power on and off the samples for 3x tiems, the samples should be able to start normally
9-8	<b>High Temperature and Humidity Storage Test</b>	Leave samples in 85℃, 95% RH @ 48 hours	4	After test, the products appearance, power, EVM and frequency error functional parameter shall be satisfied with the test specification.
9-9	<b>Low Temperature Storage Test</b>	Leave samples in -40℃, @48 hours	4	After test, the products appearance, power, EVM and frequency error functional parameter shall be satisfied with the test specification.

<b>9-10</b>	<b>Thermal Shock Test</b>	-40~85℃, dwell time: 30min. 50cycles	4	After test, the products appearance, power, EVM and frequency error functional parameter shall be satisfied with the test specification.
<b>9-11</b>	<b>Aging Test</b>	60℃, 120Hrs	10	The products at high temperature for a long time can continuous work normally
<b>9-12</b>	<b>Salt spray test</b>	NSS,35C,PH:6.5~7.2, 24H	2	The Sample shall has no minor or major defects, such as physical damage, crack, corrosion, deformation etc;
<b>9-13</b>	<b>ESD</b>	Discharge voltage: 1kV C: 50pF Discharge resistance: 330Ω Positive10 times 1 time for each second	3	The products can recoverable smoothly after ESD test.

## 10. Package (包装)

(1) 编带尺寸及方向:

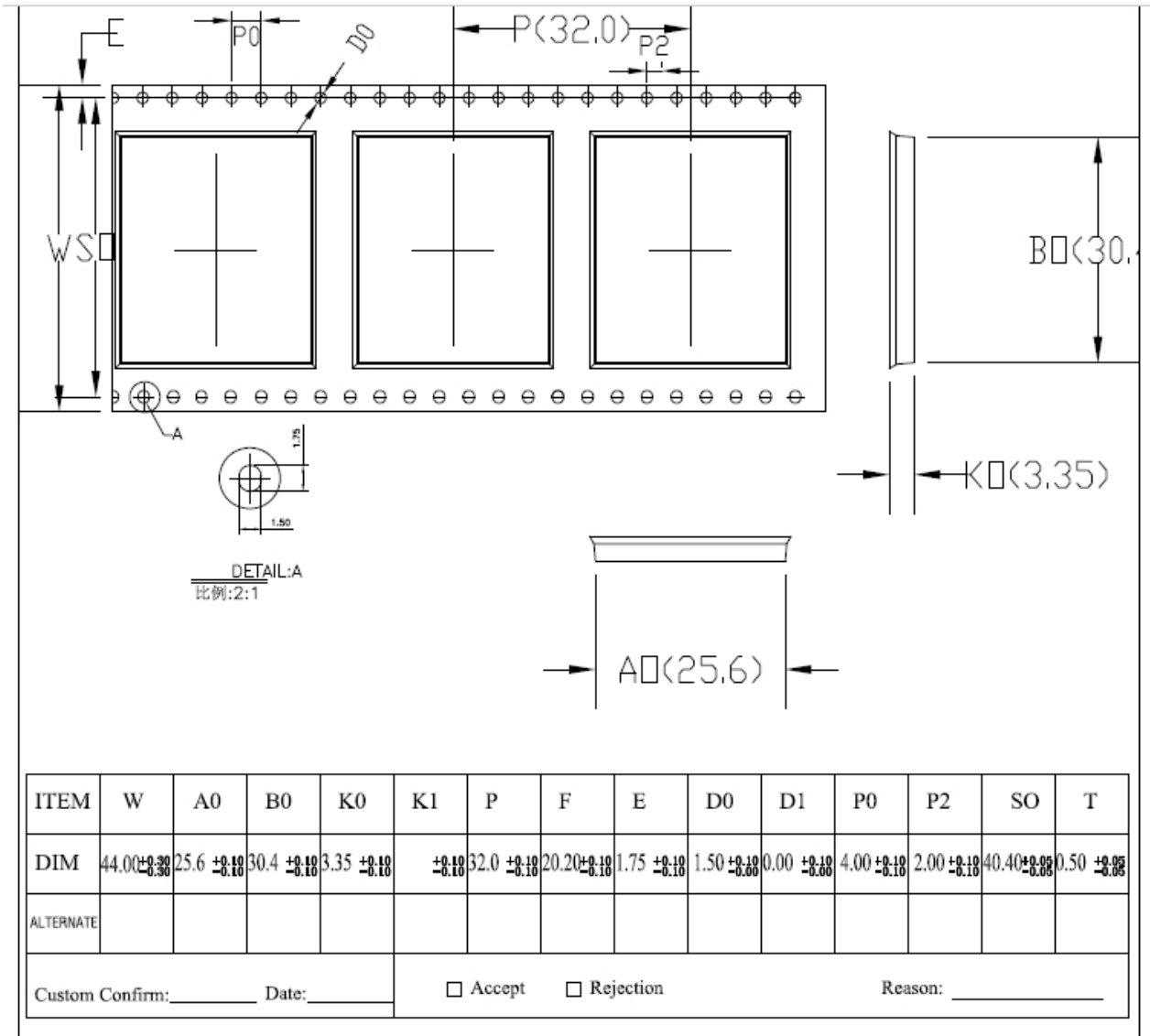

(2) 包装数量:

每卷包装数量	500	每箱包装数量	3500
--------	-----	--------	------

(3) 包装示意图:

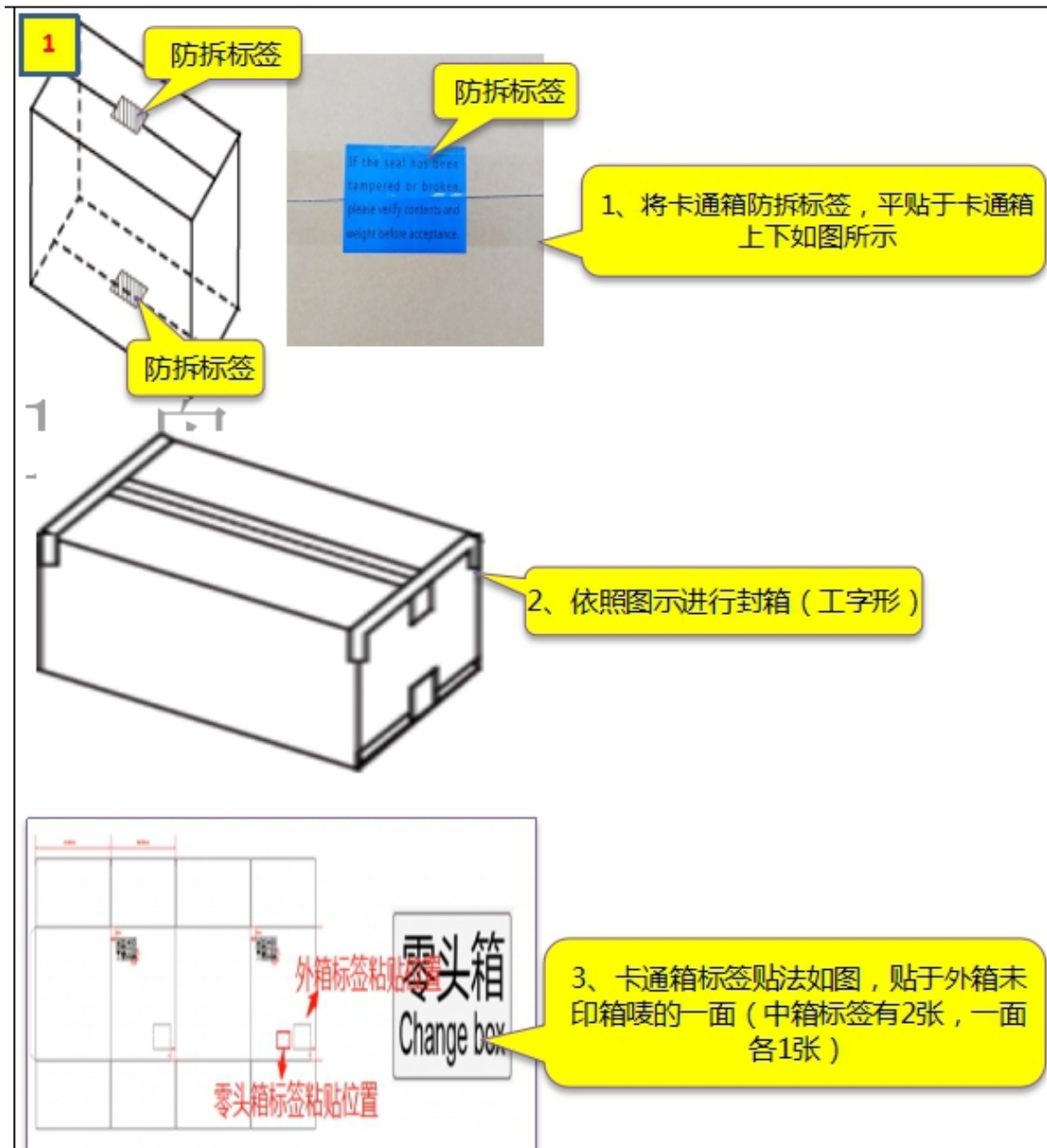

---

## FCC Statement

This device complies with Part 15 of the FCC Rules. Operation is subject to the following two conditions:

(1) this device may not cause harmful interference, and (2) this device must accept any interference received, including interference that may cause undesired operation.

Caution: The user is cautioned that changes or modifications not expressly approved by the party responsible for compliance could void the user's authority to operate the equipment.

Note: This equipment has been tested and found to comply with the limits for a Class B digital device, pursuant to part 15 of the FCC Rules. These limits are designed to provide reasonable protection against harmful interference in a residential installation. This equipment generates uses and can radiate radio frequency energy and, if not installed and used in accordance with the instructions, may cause harmful interference to radio communications. However, there is no guarantee that interference will not occur in a particular installation. If this equipment does cause harmful interference to radio or television reception, which can be determined by turning the equipment off and on, the user is encouraged to try to correct the interference by one or more of the following measures:

- Reorient or relocate the receiving antenna.
- Increase the separation between the equipment and receiver.
- Connect the equipment into an outlet on a circuit different from that to which the receiver is connected.
- Consult the dealer or an experienced radio/TV technician for help.

If power exceeds the limit and the distance (Over 20cm distance in actual use between the device and user) is compliant with the requirement

FCC RF Radiation Exposure Statement:

This equipment complies with FCC radiation exposure limits set forth for an uncontrolled environment. This equipment should be installed and operated with a minimum distance of 20cm between the radiator and any part of your body.

The device must be professionally installed

The intended use is generally not for the general public. It is generally for industry/commercial use.

The connector is within the transmitter enclosure and can only be accessed by disassembly of the transmitter that is not normally required. The user has no access to the connector.

Installation must be controlled. Installation requires special training

## Canada Statement

This device contains licence-exempt transmitter(s)/receiver(s) that comply with Innovation, Science and Economic Development Canada's licence-exempt RSS(s). Operation is subject to the following two conditions:

(1) This device may not cause interference.

(2) This device must accept any interference, including interference that may cause undesired operation of the device.

L'émetteur/récepteur exempt de licence contenu dans le présent appareil est conforme aux CNR d'Innovation, Sciences et Développement économique Canada applicables aux appareils radio exempts de licence. L'exploitation est autorisée aux deux conditions suivantes :

1) L'appareil ne doit pas produire de brouillage;

2) L'appareil doit accepter tout brouillage radioélectrique subi, même si le brouillage est susceptible d'en compromettre le fonctionnement.

---

---

Please notice that if the ISED certification number is not visible when the module is installed inside another device, then the outside of the device into which the module is installed must also display a label referring to the enclosed module. This exterior label can use wording such as the following: “ Contains IC: **26332-ELMT7668BUN**” any similar wording that expresses the same meaning may be used.

l'appareil hôte doit porter une étiquette donnant le numéro de certification du module d'Industrie Canada, précédé des mots « Contient un module d'émission », du mot « IC: **26332-ELMT7668BUN** » ou d'une formulation similaire exprimant le même sens, comme suit

The device meets the exemption from the routine evaluation limits in section 2.5 of RSS 102 and compliance with RSS-102 RF exposure, users can obtain Canadian information on RF exposure and compliance.

Le dispositif rencontre l'exemption des limites courantes d'évaluation dans la section 2.5 de RSS 102 et la conformité à l'exposition de RSS-102 rf, utilisateurs peut obtenir l'information canadienne sur l'exposition et la conformité de rf.

This transmitter must not be co-located or operating in conjunction with any other antenna or transmitter. This equipment should be installed and operated with a minimum distance of 20 centimeters between the radiator and your body.

Cet émetteur ne doit pas être Co-placé ou ne fonctionnant en même temps qu'aucune autre antenne ou émetteur. Cet équipement devrait être installé et actionné avec une distance minimum de 20 centimètres entre le radiateur et votre corps.

This radio transmitter **26332-ELMT7668BUN** has been approved by Innovation, Science and Economic Development Canada to operate with the antenna types listed below, with the maximum permissible gain indicated. Antenna types not included in this list that have a gain greater than the maximum gain indicated for any type listed are strictly prohibited for use with this device.

Le présent émetteur radio **26332-ELMT7668BUN** a été approuvé par Innovation, Sciences et Développement économique Canada pour fonctionner avec les types d'antenne énumérés ci-dessous et ayant un gain admissible maximal. Les types d'antenne non inclus dans cette liste, et dont le gain est supérieur au gain maximal indiqué pour tout type figurant sur la liste, sont strictement interdits pour l'exploitation de l'émetteur.

The concrete contents to check are the following three points.

- 1 ) Must use PCB antenna with maximum 2.64dBi (2.4G), 3.47dBi (5G) gain supplied by the manufacturer;
- 2 ) Should be installed so that the end user cannot modify the antenna;
- 3 ) Feed line should be designed in 50ohm

Fine tuning of return loss etc. can be performed using a matching network.

Le contenu concret à vérifier sont les trois points suivants.

- 1 ) utiliser une antenne PCB avec un gain maximal de 2,64 dbi (2,4 g), 3,47 dbi (5G) fourni par le fabricant;
- 2 ) doivent être installés de façon que l'utilisateur final ne peut pas modifier l'antenne
- 3 ) La ligne d'alimentation doit être conçue en 50ohm

Le réglage précis de la perte de rendement, etc. peut être effectué en utilisant un réseau correspondant.

WiFi:

Frequency (MHz) fréquences	Antenna Type types d'antenne	Antenna Gain (dBi) Gain maximal d'antenne
2412-2462	External antenna	2.64
5180-5825	External antenna	3.47

---

---

BT:

Frequency (MHz) fréquences	Antenna Type types d'antenne	Antenna Gain (dBi) Gain maximal d'antenne
2402-2480	External antenna	2.64

## Notice to OEM integrator

Must use the device only in host devices that meet the FCC/ISED RF exposure category of mobile, which means the device is installed and used at distances of at least 20cm from persons.

The end user manual shall include FCC Part 15 /ISED RSS GEN compliance statements related to the transmitter as show in this manual.

Host manufacturer is responsible for compliance of the host system with module installed with all other applicable requirements for the system such as Part 15 B, ICES 003.

Host manufacturer is strongly recommended to confirm compliance with FCC/ISED requirements for the transmitter when the module is installed in the host.

Must have on the host device a label showing Contains FCC ID: **2AWY6-ELMT7668BUN** , IC: **26332-ELMT7668BUN**

l'hôte doit utiliser l'instrument uniquement dans des dispositifs qui répondent à la fcc / (catégorie d'exposition rf mobile, ce qui signifie le dispositif est installé et utilisé à une distance d'au moins 20 cm de personnes.

le manuel de l'utilisateur final doit inclure la partie 15 / (fac rss gen déclarations de conformité relatives à l'émetteur que de montrer dans ce manuel.

le fabricant est responsable de la conformité de l'hôte, le système d'accueil avec le module installé avec toutes les autres exigences applicables du système comme la partie 15 b, ices - 003.

accueillir le fabricant est fortement recommandé de confirmer la conformité avec les exigences de la fcc / (émetteur lorsque le module est installé dans l'hôte.

le dispositif d'accueil doivent avoir une étiquette indiquant contient FCC ID:**2AWY6-ELMT7668BUN** , IC: **26332-ELMT7668BUN**

---

---

- English:

This device contains licence-exempt transmitter(s)/receiver(s) that comply with Innovation, Science and Economic Development Canada's licence-exempt RSS(s). Operation is subject to the following two conditions:

(1) This device may not cause interference; and

(2) This device must accept any interference, including interference that may cause undesired operation of the device.

- French:

Cet appareil contient des émetteurs / r é cepteurs exempt é s de licence conformes aux RSS (RSS) d'Innovation, Sciences et D é veloppement é conomique Canada. L'exploitation est autorisée aux deux conditions suivantes :

(1) l'appareil ne doit pas produire de brouillage, et

(2) l'utilisateur de l'appareil doit accepter tout brouillage radio électrique subi, même si le brouillage est susceptible d'en compromettre le fonctionnement."

---



---

## Integration instructions for host product manufacturers according to KDB 996369 D03 OEM Manual v01

### 2.2 List of applicable FCC rules

FCC Part 15 Subpart C 15.247 & 15.209&407

### 2.3 Specific operational use conditions

The module is a WIFI+BT Module

IEEE 802.11 a/b/g/n 2T/2R

Operation Frequency: 2402-2480MHz/2412-2462/ 5150 MHz~5250 MHz,  
5250 MHz~5350 MHz,  
5470 MHz~5725 MHz ,  
5725 MHz~5850 MHz

The module can be used for mobile or portable applications with a maximum

(2.4G WIFI:2.64 dBi,5G WIFI:3.47 dBi) antenna. The host

manufacturer installing this module into their product must ensure that the final composite product complies with the FCC requirements by a technical assessment or evaluation to the FCC rules, including the transmitter operation. The host manufacturer has to be aware not to provide information to the end user regarding how to install or remove this RF module in the user's manual of the end product which integrates this module. The end user manual shall include all required regulatory information/warning as show in this manual.

### 2.4 Limited module procedures

Not applicable. The module is a Single module and complies with the requirement of FCC Part 15.212.

### 2.5 Trace antenna designs

Not applicable. The module has its own antenna, and doesn't need a host's printed board microstrip trace antenna etc.

### 2.6 RF exposure considerations

The module must be installed in the host equipment such that at least **20cm** is maintained between the antenna and users' body; and if RF exposure statement or module layout is changed, then the host product manufacturer required to take responsibility of the module through a change in FCC ID or new application. The FCC ID of the module cannot be used on the final product. In these circumstances, the host manufacturer will be responsible for re-evaluating the end product (including the transmitter) and obtaining a separate FCC authorization.

### 2.7 Antennas

Antenna Specification are as follows:

Type: External photos

Gain: 2.4G WIFI:2.64 dBi

5G WIFI:3.47 dBi

This device is intended only for host manufacturers under the following conditions:

The transmitter module may not be co-located with any other transmitter or antenna;

The module shall be only used with the internal antenna(s) that has been originally tested and certified with this module. The antenna must be either permanently attached or employ a 'unique' antenna coupler.

As long as the conditions above are met, further transmitter test will not be required. However, the host manufacturer is still responsible for testing their end-product for any additional compliance requirements required with this module installed (for example, digital device emissions, PC peripheral requirements, etc.).

### 2.8 Label and compliance information

Host product manufacturers need to provide a physical or e-label stating "Contains FCC ID: **2AWY6-ELMT7668BUN**" with their finished product.

### 2.9 Information on test modes and additional testing requirements

Host manufacturer must perform test of radiated & conducted emission and spurious emission, etc according to the actual test modes for a stand-alone modular transmitter in a host, as well as for multiple simultaneously transmitting modules or other transmitters in a host product.

Only when all the test results of test modes comply with FCC requirements, then the end product can be sold legally.

### 2.10 Additional testing, Part 15 Subpart B disclaimer

The modular transmitter is **only** FCC authorized for FCC Part 15 Subpart C 15.247 & 15.209 and that the host product manufacturer is responsible for compliance to any other FCC rules that apply to the host not covered by the modular transmitter grant of certification. If the grantee markets their product as being Part 15 Subpart B compliant (when it also contains unintentional-radiator digital circuitry), then

---

---

the grantee shall provide a notice stating that the final host product still requires Part 15 Subpart B compliance testing with the modular transmitter installed.

### **Federal Communication Commission Statement (FCC, U.S.)**

This equipment has been tested and found to comply with the limits for a Class B digital device, pursuant to Part 15 of the FCC Rules. These limits are designed to provide reasonable protection against harmful interference in a residential installation. This equipment generates, uses and can radiate radio frequency energy and, if not installed and used in accordance with the instructions, may cause harmful interference to radio communications. However, there is no guarantee that interference will not occur in a particular installation. If this equipment does cause harmful interference to radio or television reception, which can be determined by turning the equipment off and on, the user is encouraged to try to correct the interference by one of the following measures:

- Reorient or relocate the receiving antenna.
- Increase the separation between the equipment and receiver.
- Connect the equipment into an outlet on a circuit different from that to which the receiver is connected.
- Consult the dealer or an experienced radio/TV technician for help.

This device complies with Part 15 of the FCC Rules. Operation is subject to the following two conditions: (1) This device may not cause harmful interference, and (2) this device must accept any interference received, including interference that may cause undesired operation.

#### **FCC Caution:**

Any changes or modifications not expressly approved by the party responsible for compliance could void the user's authority to operate this equipment.

### **IMPORTANT NOTES**

#### **Co-location warning:**

This transmitter must not be co-located or operating in conjunction with any other antenna or transmitter.

#### **OEM integration instructions:**

This device is intended only for OEM integrators under the following conditions: The transmitter module may not be co-located with any other transmitter or antenna. The module shall be only used with the external antenna(s) that has been originally tested and certified with this module.

As long as the conditions above are met, further transmitter test will not be required. However, the OEM integrator is still responsible for testing their end-product for any additional compliance requirements required with this module installed (for example, digital device emissions, PC peripheral requirements, etc.).

#### **Validity of using the module certification:**

In the event that these conditions cannot be met (for example certain laptop configurations or co-location with another transmitter), then the FCC authorization for this module in combination with the host equipment is no longer considered valid and the FCC ID of the module cannot be used on the final product. In these circumstances, the OEM integrator will be responsible for re-evaluating the end product (including the transmitter) and obtaining a separate FCC authorization.

#### **End product labeling:**

The final end product must be labeled in a visible area with the following: "Contains Transmitter Module FCC ID: **2AWY6-ELMT7668BUN**"

#### **Information that must be placed in the end user manual:**

The OEM integrator has to be aware not to provide information to the end user regarding how to install or remove this RF module in the user's manual of the end product which integrates this module. The end user manual shall include all required regulatory information/warning as show in this manual.

---