

承 認 書

SPECIFICATION FOR APPROVAL

客 戶: CUSTOMER:	
客 戶 料 號: CUST P/N:	
松 島 料 號: FINE P/N:	G43.5-6.5uH 0.08*24*2P*10TS
產 品 型 號: DESC:	Φ 43.5MMX5.0MMX0.0.65MM
日 期: DATE:	2023/05/09
版 本: Version:	A.0

擬 制 PREPARED BY	審 核 CHECKED BY	批 准 APPROVED BY	客 戶 承 認 CUSTOMER APPROVE

Shenzhen Songdao Technology Co., LTD

Factory address: 8th Floor, Building 2, Sanjia High-tech Industrial Park,
No.123 Junfa Third Road, Dongkeng Town, Dongguan City

SPECIFICATION

產品型號: DESC	Φ 20.5x38.5-6.5uH-0.08x24X2P-40mm-43 .5C	版本 Rev: A.0	客戶 CUST: 客戶料号 CUST P/N:	XXX
---------------	---	----------------	----------------------------	------------

一、尺寸 DIMENSION:(mm)

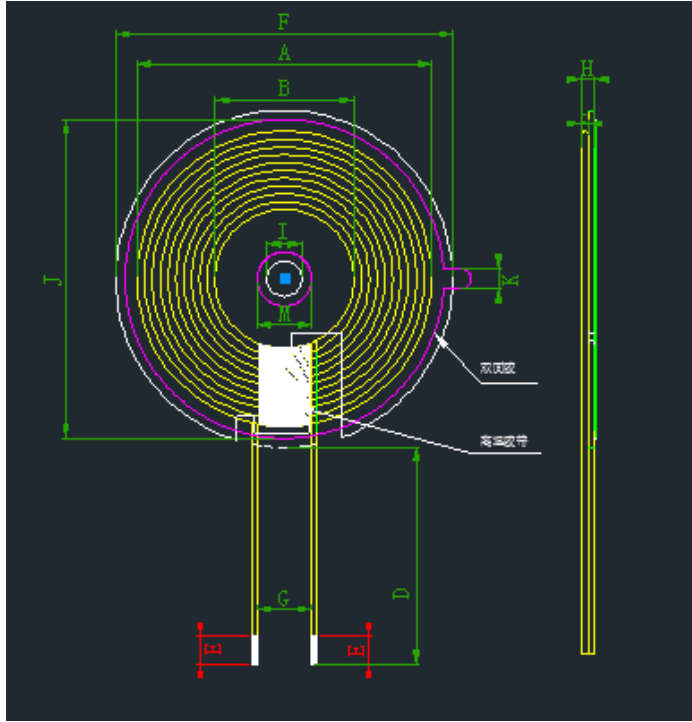

A	38.5±0.5
B	21±0.5
C	1.25 Max
D	40±2
E	3±2
F	43.5±0.5
G	8.0 ref
H	1.6 Max
I	5.3 ref
M	8.0 ref
J	42±1
K	3.0±1

注：
 1.交叉出线；
 2.出线位置缠 8mm(ref)宽度高温胶纸 1-2Ts；
 3.线圈贴圆形硬磁片带槽带背胶，磁片尺寸 43.5±0.5mm，内孔 5.3mm，厚度为 0.8±0.2mm。

二、原理图 SCHEMATIC DIAGRAM:

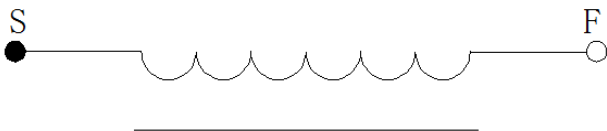

三、绕线参数 Winding Specification:

序号 NO.	端子 TERMINAL		线径 WIRE	圈数 Turns	绕线方向 Winding Direction
1	S	F	自粘漆包线 0.08*24*2 P	10Ts	CCW

四、电气特性 ELECTRICAL CHARACTERISTICS:

温度 TEMPERATURE:25±10°C, 湿度 RELATIVE HUMIDITY:65±20%

序号 NO.	项目 ITEM	端子 TERMINAL	标准 SPECIFICATION	测试条件 TEST FREQUENCY	测试仪器 TEST EQUIPMENTS
1	IND.	S-F	3.8uH ±10%单独线圈	100KHz/0.25V	LCZ METER 1062B
2	IND.	S-F	6.5uH ±10%加磁片	100KHz/0.25V	LCZ METER 1062B
3	DCR	S-F	≤85mΩ	100KHz/0.25V	LCZ METER 502B
4	Q 值	S-F	≥33	100KHz/0.25V	LCZ METER 502B

擬制/日期 PREPARED BY/DATE	審核/日期 CHECKED BY/DATE
黄燕铭 2023/05/09	黄锦华 2023/05/09

