

RF Test Report

Applicant : Verkada Inc
Product Name : Keypad Door Reader
Trade Name :  Verkada
Model Number : AD64-HW
Applicable Standard : FCC 47 CFR PART 15 SUBPART C
ANSI C63.10:2013
Received Date : Aug. 01, 2024
Test Period : Aug. 07, 2024 ~ Aug. 09, 2024
Issued Date : Sep. 10, 2024

Issued by

Eurofins E&E Wireless Taiwan Co., Ltd.
No. 140-1, Changan Street, Bade District,
Taoyuan City 334025, Taiwan (R.O.C.)
Tel : +886-3-2710188 / Fax : +886-3-2710190



Taiwan Accreditation Foundation accreditation number: 1330
Frequency Range: 9 kHz to 325 GHz
Bade test site :
Test Firm Registration Number: 226252
Test Firm Designation Number: TW0010
Wugu test site :
Test Firm Registration Number: 191812
Test Firm Designation Number: TW0034

Note:

- 1.The test results are valid only for samples provided by customers and under the test conditions described in this report.
- 2.This report shall not be reproduced except in full, without the written approval of Eurofins E&E Wireless Taiwan Co., Ltd.
- 3.The relevant information is provided by customers in this test report. According to the correctness, appropriateness or completeness of the information provided by the customer, if there is any doubt or error in the information which affects the validity of the test results, the laboratory does not take the responsibility.

Revision History

| Rev. | Issued Date | Description | Revised by |
|------|---------------|---------------|-------------|
| 00 | Sep. 10, 2024 | Initial Issue | Rowan Hsieh |
| | | | |
| | | | |
| | | | |

Verification of Compliance

Applicant : Verkada Inc

Product Name : Keypad Door Reader

Trade Name :  Verkada

Model Number : AD64-HW

FCC ID : 2AWUU60B0701

Applicable Standard : FCC 47 CFR PART 15 SUBPART C
ANSI C63.10:2013

Test Result : Complied

Performing Lab. : Eurofins E&E Wireless Taiwan Co., Ltd.
No. 140-1, Changan Street, Bade District,
Taoyuan City 334025, Taiwan (R.O.C.)
Tel : +886-3-2710188 / Fax : +886-3-2710190
Taiwan Accreditation Foundation accreditation number: 1330



Eurofins E&E Wireless Taiwan Co., Ltd. tested the above equipment in accordance with the requirements set forth in the above standards. All indications of Pass/Fail in this report are opinions expressed by Eurofins E&E Wireless Taiwan Co., Ltd. based on interpretations and/or observations of test results. The test results show that the equipment tested is capable of demonstrating compliance with the requirements as documented in this report.

Approved By : _____

TABLE OF CONTENTS

| | | |
|----------|--|-----------|
| 1 | General Information | 5 |
| 1.1. | Summary of Test Result..... | 5 |
| 1.2. | Testing Location..... | 5 |
| 1.3. | Measurement Uncertainty..... | 6 |
| 1.4. | Test Site Environment..... | 6 |
| 2 | EUT Description | 7 |
| 3 | Test Methodology | 8 |
| 3.1. | Mode of Operation | 8 |
| 3.2. | EUT Test Step..... | 8 |
| 3.3. | Configuration of Test System Details | 9 |
| 3.4. | Test Instruments | 10 |
| 4 | Measurement Procedure | 12 |
| 4.1. | AC Power Line Conducted Emission Measurement | 12 |
| 4.2. | Radiated Emission Measurement | 14 |
| 4.3. | Antenna Requirement..... | 18 |
| 5 | Test Results | 19 |
| 5.1. | Conducted Emission..... | 19 |
| 5.2. | Radiated Emission Measurement..... | 21 |

Appendix A. Test Setup Photographs

1 General Information

1.1. Summary of Test Result

| Standard | Item | Results | Remark |
|--------------------------|-----------------------------|--------------|--------|
| 15.203 | Antenna Requirement | Meet Require | --- |
| 15.207(a) | Conducted Emissions Voltage | PASS | --- |
| 15.205 (a) 15.209 (a) | Radiated Emission Limits | PASS | --- |

Decision Rule

- Uncertainty is not included.
- Uncertainty is included.

| Standard | Description |
|---------------------------|--|
| CFR47, Part 15, Subpart C | Intentional Radiators |
| ANSI C63. 10: 2013 | American National Standard of Procedures for Compliance Testing of Unlicensed Wireless Devices |

1.2. Testing Location

Lab Name: Eurofins E&E Wireless Taiwan Co., Ltd.

Site Address: No. 140-1, Changan Street, Bade District, Taoyuan City 334025, Taiwan (R.O.C.)

Site Address: No. 2, Wuquan 5th Rd. Wugu Dist., New Taipei City, Taiwan (R.O.C.)

1.3. Measurement Uncertainty

| Test Item | Frequency | Uncertainty | | | | |
|--------------------|-----------------------|-------------|----------|----------|----------|----------|
| | | BD | | WG | | |
| Conducted Emission | 150 kHz ~ 30 MHz | 2.7 dB | | 2.6 dB | | |
| Test Item | Frequency | Uncertainty | | | | |
| | | 96601-BD | 96603-BD | 96602-WG | 96603-WG | 96604-WG |
| Radiated Emission | 9 kHz ~ 30 MHz | 1.8 dB | 1.8 dB | 1.9 dB | 1.9 dB | 1.9 dB |
| | 30 MHz ~ 1000 MHz | 4.7 dB | 4.7 dB | 4.7 dB | 4.7 dB | 4.5 dB |
| | 1000 MHz ~ 18000 MHz | 4.7 dB | 4.8 dB | 4.6 dB | 4.7 dB | 5.1 dB |
| | 18000 MHz ~ 26500 MHz | 4.0 dB | 4.1 dB | 3.9 dB | 4.1 dB | 4.3 dB |
| | 26500 MHz ~ 40000 MHz | 4.2 dB | 4.2 dB | 4.2 dB | 4.2 dB | 4.6 dB |

1.4. Test Site Environment

| Items | Required (IEC 60068-1) | Interval(*) |
|------------------|------------------------|-------------|
| Temperature (°C) | 15-35 | 20-30 |
| Humidity (%RH) | 25-75 | 45-75 |

(*)The measurement ambient temperature is within this range.

2 EUT Description

The product specifications of the EUT presented in the report are declared by the manufacturer who shall take full responsibility for the authenticity

| | |
|---------------------|---|
| Applicant | Verkada Inc 405 E. 4th Ave. San Mateo California 94401 United States |
| Product Name | Keypad Door Reader |
| Trade Name |  Verkada |
| Model Number | AD64-HW |
| FCC ID | 2AWUU60B0701 |
| Frequency Range | 125 kHz |
| Modulation Type | FSK |
| Number of Channels | 1 Channel |
| Antenna Type | Coil Antenna |
| Operate Temp. Range | -40 ~ 65 °C |
| EUT Power Rating | DC 12 V, 250 mA |

Note : All measurements were performed radiated and therefore additional antenna gain is not required.

3 Test Methodology

3.1. Mode of Operation

The following test mode(s) were scanned during the preliminary test :

| |
|---------------|
| Test Mode |
| Transmit Mode |

After verification, all tests were carried out with the worst case test modes.

Eurofins has verified the construction and function in typical operation. All the test modes were carried out with the EUT in normal operation.

By preliminary testing and verifying three axis (X,Y and Z) position of EUT transmitted status, it was found that “Y axis” position was the worst, then the final test was executed the worst condition and test data were recorded in this report

| Test Mode | Frequency (kHz) | Test Software Version |
|---------------|-----------------|-----------------------|
| Transmit Mode | 125 | Engineering Mode |

3.2. EUT Test Step

| | |
|----|--|
| 1. | Setup the EUT shown on “Configuration of Test System Details.” |
| 2. | Turn on the power of all equipment. |
| 3. | The EUT will start to operate function. |

3.3. Configuration of Test System Details

Radiated Emissions & Conduction Emission

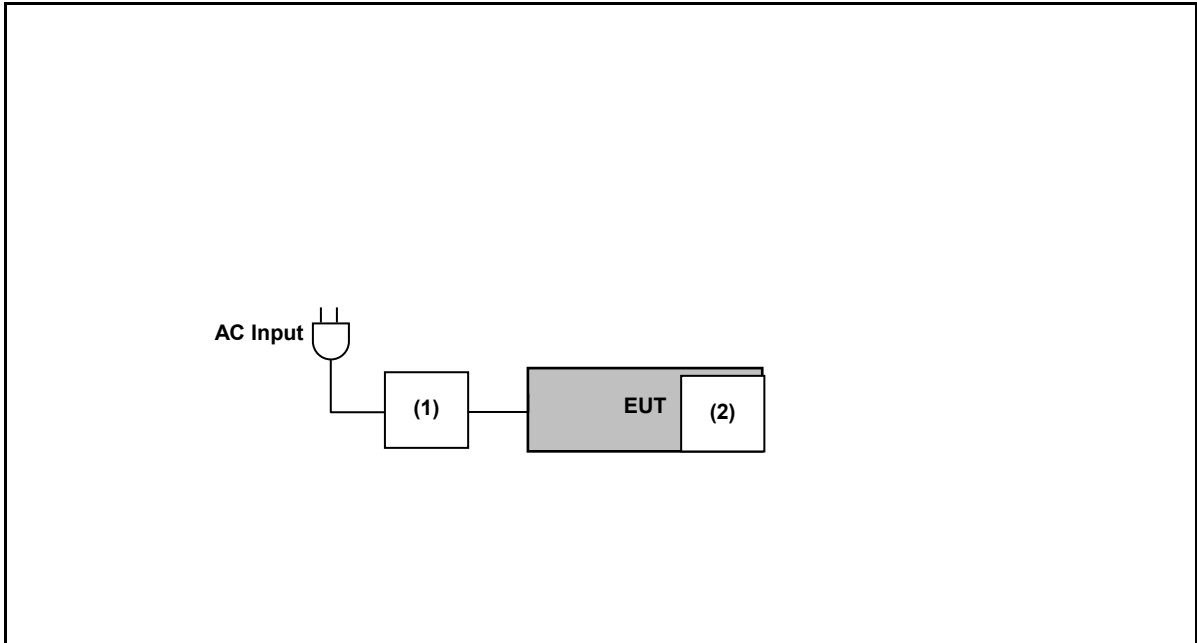

| Devices Description | | | | | |
|---------------------|--------------|--------------|--------------|---------------|------------|
| | Product | Manufacturer | Model Number | Serial Number | Power Cord |
| (1) | Power Supply | RIGOL | DP711 | DP7A243601513 | V |
| (2) | RFID CARD | --- | --- | --- | --- |

3.4. Test Instruments

For Radiated Emissions

Test Period: Aug. 07, 2024 ~ Aug. 09, 2024

Testing Engineer: Marin Lee

| Radiation test sites | | Semi Anechoic Room 96602-WG | | | | |
|-------------------------------------|--|--------------------------------|--------------------------|---------------|---------------|-------------|
| Use | Equipment | Manufacturer | Model Number | Serial Number | Cal. Date | Cal. Period |
| <input checked="" type="checkbox"/> | LOOP Antenna (9 kHz~30 MHz) | Schwarzbeck Mess-Elektronik | FMZB 1513-60 | 00031 | Feb. 23, 2024 | 1 year |
| <input checked="" type="checkbox"/> | Trilog Broadband Antenna (30 MHz~1 GHz) | Schwarzbeck Mess-Elektronik | VULB9168 | 01276 | Feb. 02, 2024 | 1 year |
| <input checked="" type="checkbox"/> | Spectrum Analyzer (10 Hz~44 GHz) | KEYSIGHT | N9020B | MY60112362 | Jan. 29, 2024 | 1 year |
| <input checked="" type="checkbox"/> | Pre-Amplifier | Agilent | 8447D | 2944A10961 | Jul. 9, 2024 | 1 year |
| <input checked="" type="checkbox"/> | Power Supply | RIGOL | DP711 | DP7A243601513 | Nov. 16, 2023 | 1 year |
| <input checked="" type="checkbox"/> | Coaxial Cable (10 kHz~3000 MHz) | EMCI | EMCCFD400-NM- NM-2000 | 211006 | Nov. 13, 2023 | 1 year |
| <input checked="" type="checkbox"/> | Coaxial Cable (10 kHz~3000 MHz) | EMCI | EMCCFD400-NM- NM-2000 | 211007 | Nov. 13, 2023 | 1 year |
| <input checked="" type="checkbox"/> | Coaxial Cable (10 kHz~3000 MHz) | EMCI | EMCCFD400-NM- NM-6000 | 211015 | Nov. 13, 2023 | 1 year |
| <input checked="" type="checkbox"/> | Software | R_RAM | V1.3 | N/A | N.C.R. | --- |

Note: N.C.R. = No Calibration Request.

For Conduction Emissions
 Test Period: Aug. 09, 2024
 Testing Engineer: Marin Lee

| Radiation test sites | | Conducted Emission Measurement Conduction01-WG | | | | |
|-------------------------------------|---------------|--|----------------------|---------------|---------------|-------------|
| Use | Equipment | Manufacturer | Model Number | Serial Number | Cal. Date | Cal. Period |
| <input checked="" type="checkbox"/> | Test Receiver | R&S | ESR3 | 102919 | Nov 30, 2023 | 1 year |
| <input checked="" type="checkbox"/> | LISN | R&S | ENV216 | 101041 | Apr 8, 2024 | 1 year |
| <input checked="" type="checkbox"/> | Power Supply | RIGOL | DP711 | DP7A243601513 | Nov. 16, 2023 | 1 year |
| <input checked="" type="checkbox"/> | Cable | EMCI | EMCCFD300-BM-NM-4000 | 220402 | Jun 12, 2024 | 1 year |
| <input checked="" type="checkbox"/> | Software | ELEKTRA | 94.50.4 | N.A. | N.C.R. | N.C.R. |

Note: N.C.R. = No Calibration Request.

4 Measurement Procedure

4.1. AC Power Line Conducted Emission Measurement

■ Limit

| Frequency (MHz) | Quasi-peak | Average |
|-----------------|------------|----------|
| 0.15 - 0.5 | 66 to 56 | 56 to 46 |
| 0.50 - 5.0 | 56 | 46 |
| 5.0 - 30.0 | 60 | 50 |

■ Test Setup

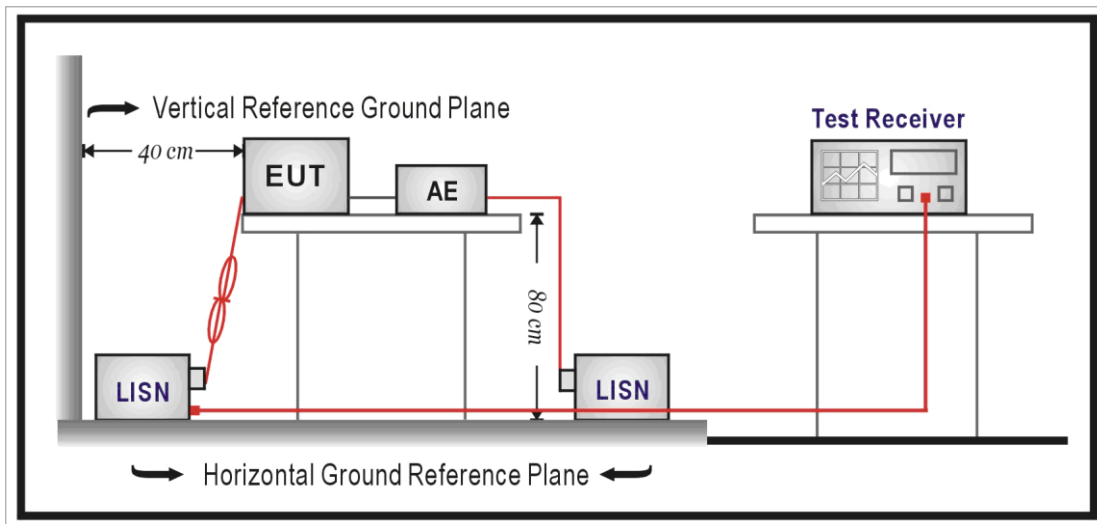

■ Test Procedure

The EUT and simulators are connected to the main power through a line impedance stabilization network (L.I.S.N.). This provides a $50 \Omega // 50 \mu\text{H}$ coupling impedance for the measuring equipment. The peripheral devices are also connected to the main power through a LISN that provides a $50 \Omega // 50 \mu\text{H}$ coupling impedance with 50 ohm termination.

Tabletop device shall be placed on a non-conducting platform, of nominal size 1 m by 1.5 m, raised 80 cm above the reference ground plane. The wall of screened room shall be located 40 cm to the rear of the EUT. Other surfaces of tabletop or floor standing EUT shall be at least 80 cm from any other ground conducting surface including one or more LISNs. For floor-standing device shall be placed under the EUT with a 12 mm insulating material.

Conducted emissions were investigated over the frequency range from 0.15 MHz to 30 MHz using a resolution bandwidth of 9 kHz. The equipment under test (EUT) shall be meet the limits in section 4.1, as applicable, including the average limit and the quasi-peak limit when using respectively, an average detector and quasi-peak detector measured in accordance with the methods described of related standard. When all of peak value were complied with quasi-peak and average limit from 150 kHz to 30 MHz then quasi-peak and average measurement was unnecessary.

The AMN shall be placed 0.8 m from the boundary of the unit under test and bonded to a ground reference plane for AMNs mounted on top of the ground reference plane. This distance is between the closest points of the AMN and the EUT. All other units of the EUT and associated equipment shall be at least 0.8 m from the AMN. If the mains power cable is longer than 1 m then the cable shall be folded back and forth at the centre of the lead to form a bundle no longer than 0.4 m. All of interconnecting cables that hang closer than 40 cm to the ground plane shall be folded back and forth in the center forming a bundle 30 cm to 40 cm long. All of EUT and AE shall be separate place more than 0.1 m. All 50 Ω ports of the LISN shall be resistively terminated into 50 Ω loads when not connected to the measuring instrument.

If the reading of the measuring receiver shows fluctuations close to the limit, the reading shall be observed for at least 15 s at each measurement frequency; the higher reading shall be recorded with the exception of any brief isolated high reading which shall be ignored.

4.2. Radiated Emission Measurement

■ Limit

According to §15.209(a), except as provided elsewhere in this subpart, the emissions from an intentional radiator shall not exceed the field strength levels specified in the following table:

| Frequency (MHz) | Field Strength ($\mu\text{V/m}$ at meter) | Measurement Distance (meter) |
|--------------------|---|---------------------------------|
| 0.009 – 0.490 | 2400 / F (kHz) | 300 |
| 0.490 – 1.705 | 24000 / F (kHz) | 30 |
| 1.705 – 30.0 | 30 | 30 |
| 30 - 88 | 100** | 3 |
| 88-216 | 150** | 3 |
| 216-960 | 200** | 3 |
| Above 960 | 500 | 3 |

** Except as provided in paragraph (g), fundamental emissions from intentional radiators operating under this Section shall not be located in the frequency bands 54-72 MHz, 76-88 MHz, 174-216 MHz or 470-806 MHz. However, operation within these frequency bands is permitted under other sections of this Part, e.g., Sections 15.231 and 15.241.

■ Setup

9 kHz ~ 30 MHz

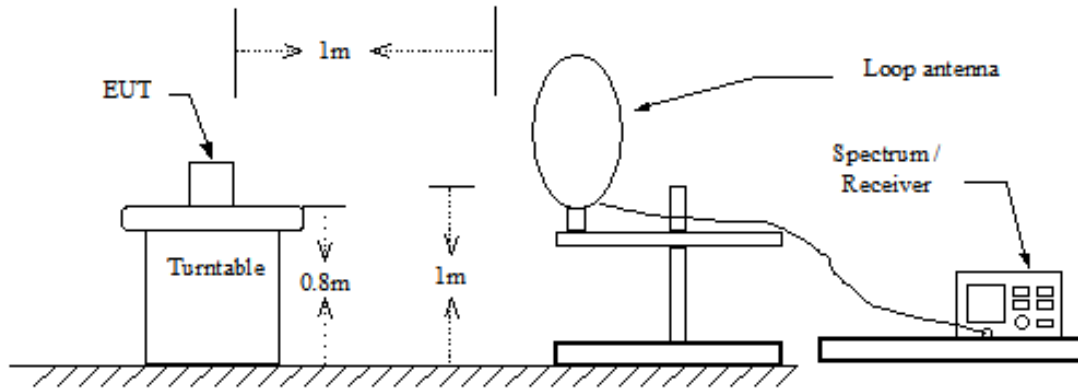

30 MHz ~ 1 GHz

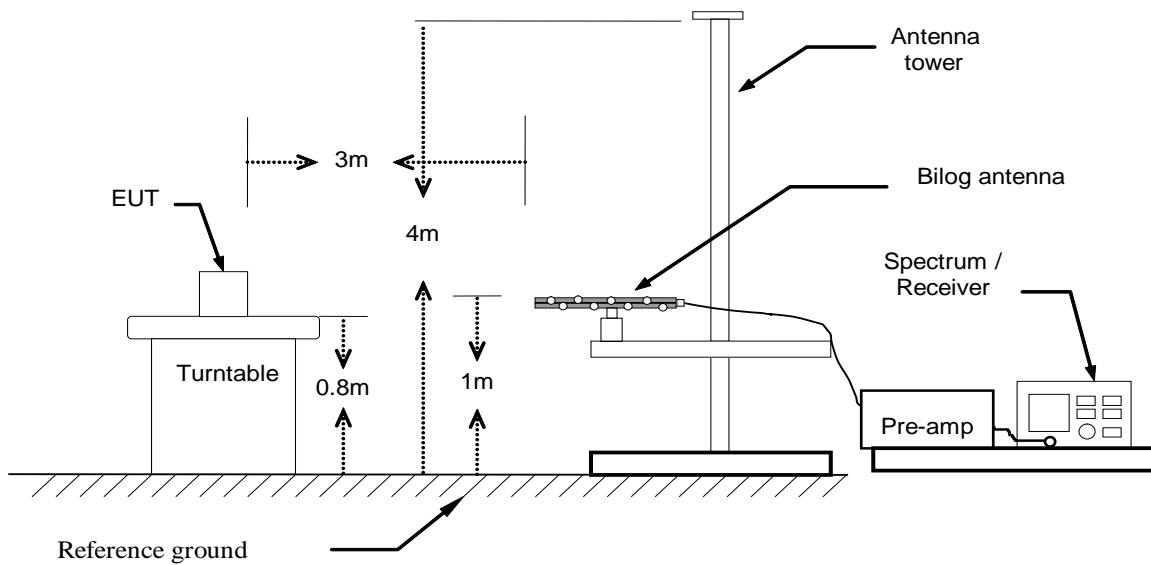

■ Test Procedure

Final radiation measurements were made on a three-meter Semi Anechoic Chamber. The EUT system was placed on a nonconductive turntable which is 0.8 meters height, top surface 1.0 x 1.5 meter. The spectrum was examined from 3 Hz to 44 GHz in order to cover the whole spectrum below 10th harmonic which could generate from the EUT. During the test, EUT was set to transmit continuously.

For measurements below 30 MHz the resolution bandwidth is set to 10 kHz for peak detection measurements or 9 kHz for quasi-peak detection measurements. The video bandwidth is 3 times of the resolution bandwidth.

For measurements below 1 GHz the resolution bandwidth is set to 100 kHz for peak detection measurements or 120 kHz for quasi-peak detection measurements. Peak detection is used unless otherwise noted as quasi-peak.

For measurements above 1 GHz the resolution bandwidth is set to 1 MHz, and then the video bandwidth is set to 3 MHz for peak measurements and 10 Hz for average measurements.

A nonconductive material surrounded the EUT to supporting the EUT for standing on three orthogonal planes. At each condition, the EUT was rotated 360 degrees, and the antenna was raised and lowered from one to four meters to find the maximum emission levels. Measurements were taken using both horizontal and vertical antenna polarization.

Broadband/Horn Antenna were used in frequency 30 MHz to 18 GHz at a distance of 3 meter. Loop/Horn Antenna was used in frequency 9 kHz to 30 MHz and 18 to 26.5 GHz at a distance of 1 meter. All test results were extrapolated to equivalent signal at 3 meters utilizing an inverse linear distance extrapolation Factor (20 dB/decade).

For testing above 1 GHz, the emission level of the EUT in peak mode was 20 dB lower than average limit (that means the emission level in peak mode also complies with the limit in average mode), then testing will be stopped and peak values of EUT will be reported, otherwise, the emissions will be measured in average mode again and reported.

Appropriate preamplifiers were used for improving sensitivity and precautions were taken to avoid overloading or desensitizing the spectrum analyzer. No post – detector video filters were used in the test.

The spectrum analyzer's 6 dB bandwidth was set to 1 MHz, and the analyzer was operated in the peak detection mode, for frequencies both below and up 1 GHz. The average levels were obtained by subtracting the duty cycle correction factor from the peak readings.

The following procedures were used to convert the emission levels measured in decibels referenced to 1 microvolt (dBuV) into field intensity in microvolt pre-meter (uV/m).

The actual field intensity in decibels referenced to 1 microvolt in to field intensity in microvolt per-meter (dBuV/m).

The actual field intensity in referenced to 1 microvolt per meter (dBuV/m) is determined by algebraically adding the measured reading in dBuV, the antenna factor (dB), and cable loss (dB) and Subtracting the gain of preamplifier (dB) is auto calculate in spectrum analyzer.

$$(1) \text{ Amplitude (dBuV/m) = FI (dBuV) +AF (dBuV) +CL (dBuV)-Gain (dB)}$$

FI= Reading of the field intensity.

AF= Antenna factor.

CL= Cable loss.

P.S Amplitude is auto calculate in spectrum analyzer.

$$(2) \text{ Actual Amplitude (dBuV/m) = Amplitude (dBuV)-Dis(dB)}$$

The FCC specified emission limits were calculated according the EUT operating frequency and by following linear interpolation equations:

(a) For fundamental frequency : Transmitter Output < +30 dBm

(b) For spurious frequency : Spurious emission limits = fundamental emission limit /10

Data of measurement within this frequency range without mark in the table above means the reading of emissions are attenuated more than 20 dB below the permissible limits or the field strength is too small to be measured.

4.3. Antenna Requirement

- **Require**

An intentional radiator shall be designed to ensure that no antenna other than that furnished by the responsible party shall be used with the device. The use of a permanently attached antenna or of an antenna that uses a unique coupling to the intentional radiator shall be considered sufficient to comply with the provisions of this section. The manufacturer may design the unit so that a broken antenna can be replaced by the user, but the use of a standard antenna jack or electrical connector is prohibited.

- **Antenna Connector Construction**

See section 2 – antenna information.

5 Test Results

5.1. Conducted Emission

| | | | |
|--------------|--------------------|--------|----------------|
| Standard: | FCC Part 15C | Line: | L1 |
| Test item: | Conducted Emission | Power: | AC 120 V/60 Hz |
| Mode: | Transmit Mode | | |
| Description: | | | |

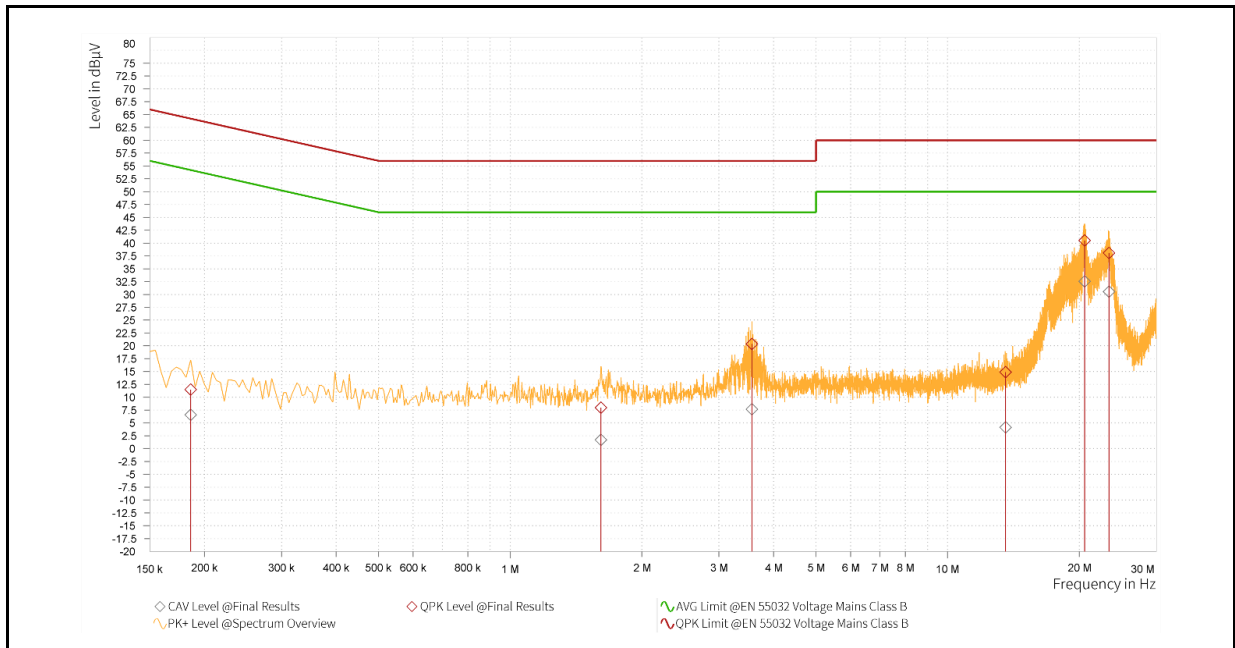

| Rg | Frequency [MHz] | QP Result [dBµV] | QP Limit [dBµV] | QP Margin [dB] | AV Result [dBµV] | AV Limit [dBµV] | AV Margin [dB] | Correction factor [dB] | Line |
|----|-----------------|------------------|-----------------|----------------|------------------|-----------------|----------------|------------------------|------|
| 1 | 0.186 | 11.48 | 64.21 | 52.73 | 6.59 | 54.21 | 47.62 | 9.61 | L1 |
| 1 | 1.613 | 7.96 | 56.00 | 48.04 | 1.71 | 46.00 | 44.29 | 9.65 | L1 |
| 1 | 3.570 | 20.39 | 56.00 | 35.61 | 7.67 | 46.00 | 38.33 | 9.70 | L1 |
| 1 | 13.560 | 14.88 | 60.00 | 45.12 | 4.12 | 50.00 | 45.88 | 9.84 | L1 |
| 1 | 20.562 | 40.49 | 60.00 | 19.51 | 32.54 | 50.00 | 17.46 | 9.88 | L1 |
| 1 | 23.384 | 38.08 | 60.00 | 21.92 | 30.56 | 50.00 | 19.44 | 9.89 | L1 |

Note: 1. Result (dBuV) = Correction factor (dB) + Reading(dBuV).

2. Correction factor (dB) = Cable loss (dB) + L.I.S.N. factor (dB).

| | | | |
|--------------|--------------------|--------|----------------|
| Standard: | FCC Part 15C | Line: | N |
| Test item: | Conducted Emission | Power: | AC 120 V/60 Hz |
| Mode: | Transmit Mode | | |
| Description: | | | |

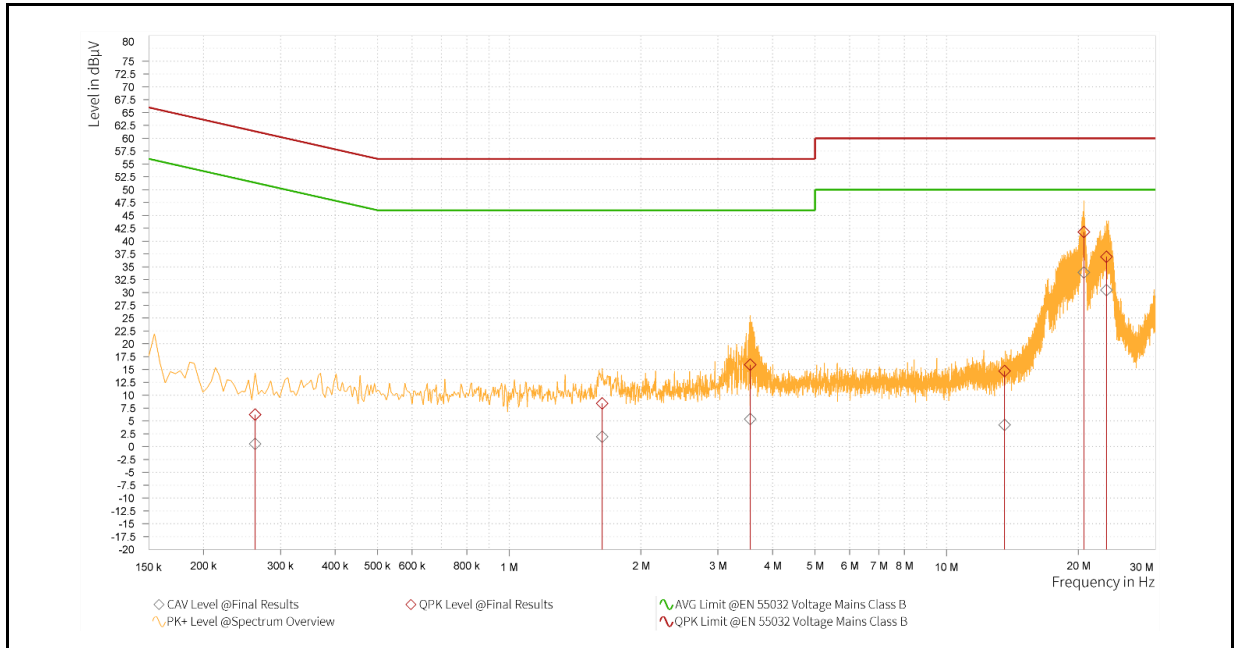

| Rg | Frequency [MHz] | QP Result [dBµV] | QP Limit [dBµV] | QP Margin [dB] | AV Result [dBµV] | AV Limit [dBµV] | AV Margin [dB] | Correction factor [dB] | Line |
|----|-----------------|------------------|-----------------|----------------|------------------|-----------------|----------------|------------------------|------|
| 1 | 0.263 | 6.22 | 61.35 | 55.13 | 0.52 | 51.35 | 50.83 | 9.59 | N |
| 1 | 1.631 | 8.42 | 56.00 | 47.58 | 1.92 | 46.00 | 44.08 | 9.65 | N |
| 1 | 3.557 | 15.92 | 56.00 | 40.08 | 5.37 | 46.00 | 40.63 | 9.70 | N |
| 1 | 13.560 | 14.72 | 60.00 | 45.28 | 4.22 | 50.00 | 45.78 | 9.92 | N |
| 1 | 20.589 | 41.79 | 60.00 | 18.21 | 33.89 | 50.00 | 16.11 | 10.04 | N |
| 1 | 23.195 | 36.92 | 60.00 | 23.08 | 30.46 | 50.00 | 19.54 | 10.07 | N |

Note: 1. Result (dBuV) = Correction factor (dB) + Reading(dBuV).

2. Correction factor (dB) = Cable loss (dB) + L.I.S.N. factor (dB).

5.2. Radiated Emission Measurement

Harmonic

9 kHz ~ 30 MHz:

| | | | |
|-------------|---------------|----------------|----------|
| Standard: | FCC Part 15C | Test Distance: | 300/30 m |
| Test item: | Harmonic | | |
| Mode: | Transmit Mode | | |
| Ant.Polar.: | Horizontal | | |

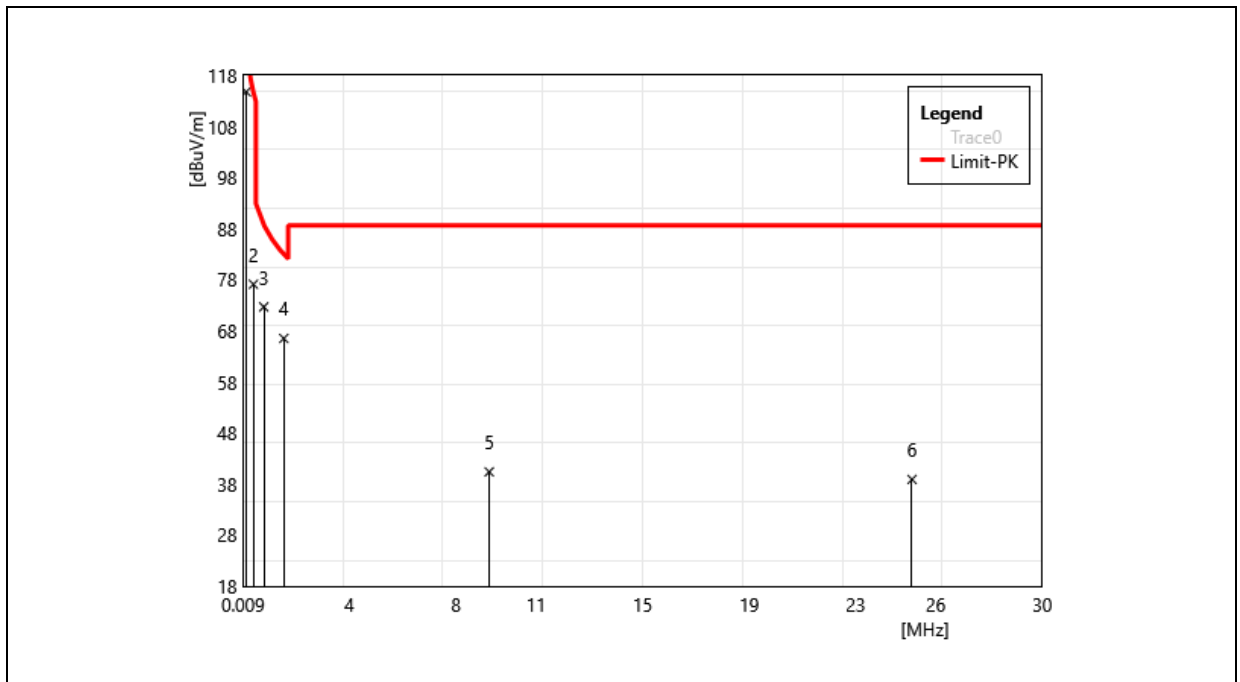

| No. | Frequency (MHz) | Reading (dBuV) | Correct Factor (dB/m) | Near-Field Result (dBuV/m) | Derived Value (dBuV/m) | Limit (dBuV/m) | Margin (dB) | Remark |
|-----|-----------------|----------------|-----------------------|----------------------------|------------------------|----------------|-------------|--------|
| 1 | 0.128 | 95.89 | 18.87 | 114.76 | 13.78 | 25.46 | -11.68 | QP |
| 2 | 0.4 | 57.91 | 19.20 | 77.11 | -13.97 | 15.56 | -29.53 | QP |
| 3 | 0.79 | 53.46 | 19.22 | 72.68 | 7.51 | 29.65 | -22.14 | QP |
| 4 | 1.54 | 47.30 | 19.20 | 66.50 | 7.13 | 23.85 | -16.72 | QP |
| 5 | 9.25 | 19.58 | 20.80 | 40.39 | -3.41 | 29.54 | -32.95 | QP |
| 6 | 25.11 | 15.95 | 22.96 | 38.91 | 3.79 | 29.54 | -25.75 | QP |

Note: The level is measured at 1 meter and is converted into result at 300 or 30 meter.

| | | | |
|-------------|---------------|----------------|----------|
| Standard: | FCC Part 15C | Test Distance: | 300/30 m |
| Test item: | Harmonic | | |
| Mode: | Transmit Mode | | |
| Ant.Polar.: | Vertical | | |

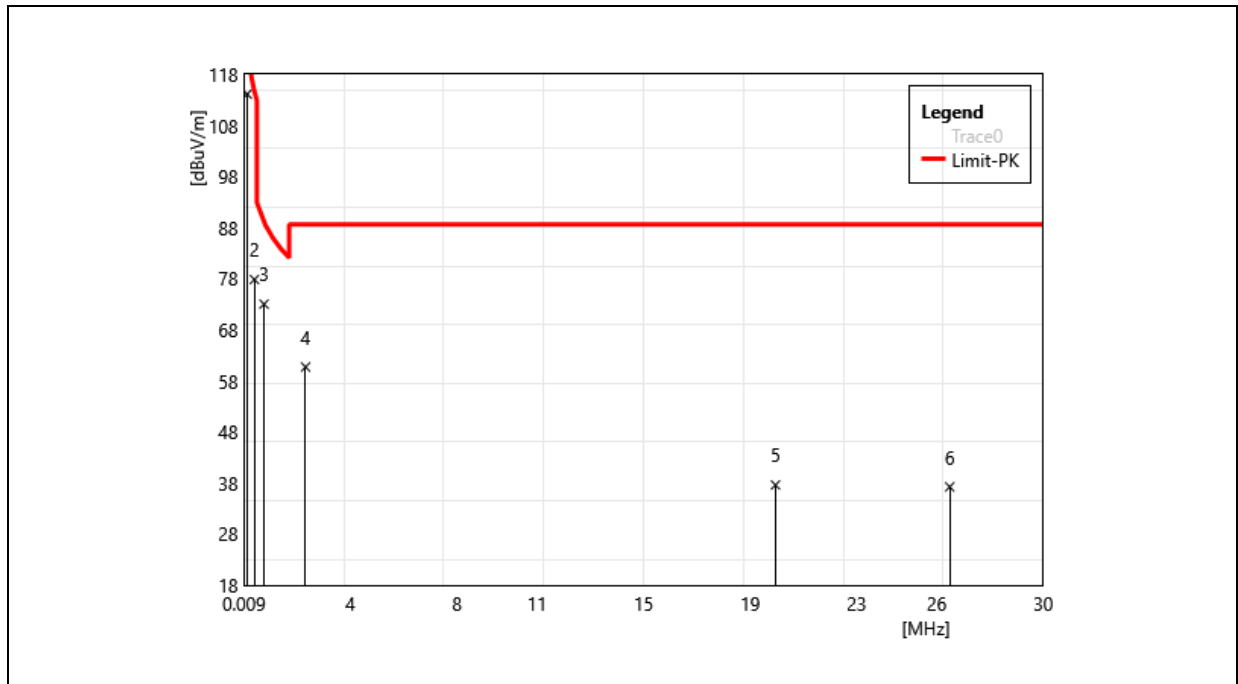

| No. | Frequency (MHz) | Reading (dBuV) | Correct Factor (dB/m) | Near-Field Result (dBuV/m) | Derived Value (dBuV/m) | Limit (dBuV/m) | Margin (dB) | Remark |
|-----|-----------------|----------------|-----------------------|----------------------------|------------------------|----------------|-------------|--------|
| 1 | 0.128 | 95.26 | 18.87 | 114.13 | 13.15 | 25.46 | -12.31 | QP |
| 2 | 0.4 | 58.63 | 19.20 | 77.83 | -13.25 | 15.56 | -28.81 | QP |
| 3 | 0.76 | 53.77 | 19.25 | 73.02 | 7.52 | 29.99 | -22.47 | QP |
| 4 | 2.32 | 41.57 | 19.15 | 60.72 | 4.91 | 29.54 | -24.63 | QP |
| 5 | 19.95 | 15.27 | 22.37 | 37.64 | 0.53 | 29.54 | -29.01 | QP |
| 6 | 26.49 | 14.62 | 22.63 | 37.25 | 2.60 | 29.54 | -26.94 | QP |

Note: The level is measured at 1 meter and is converted into result at 300 or 30 meter.

30 MHz ~ 1 GHz:

| | | | |
|---------------|---------------|-----------|--------------|
| Test Site: | 96602 - WG | Standard: | FCC Part 15C |
| Test Mode: | Transmit Mode | | |
| Polarization: | Horizontal | | |
| Remark: | | | |

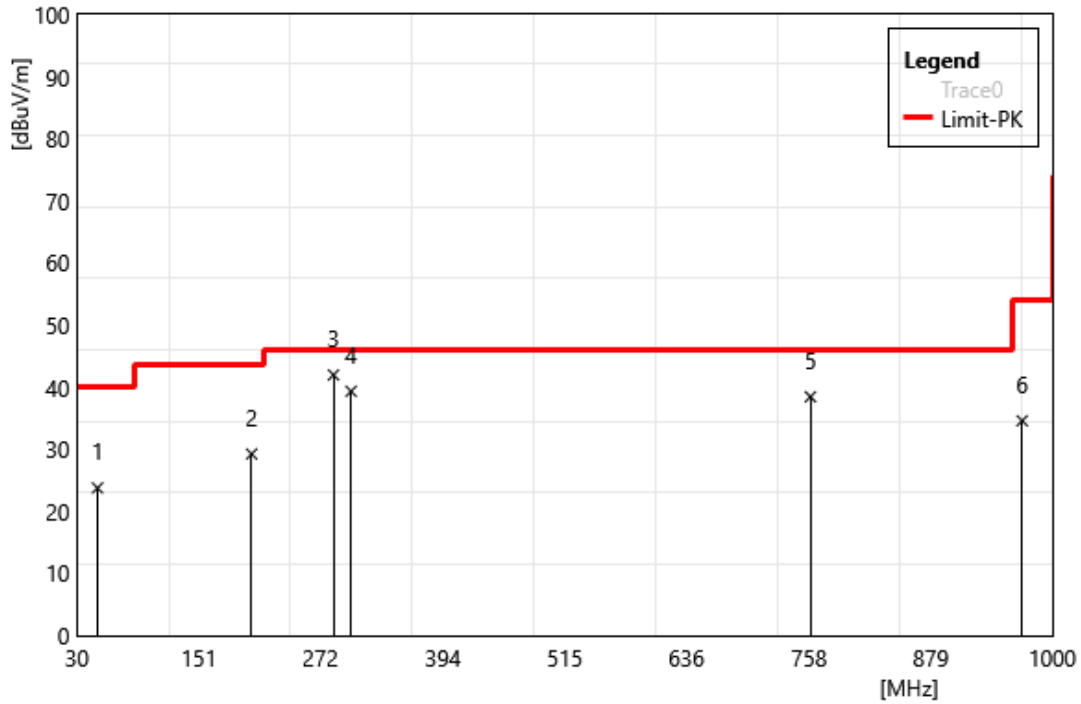

| ID | Frequency MHz | Reading dBuV | Correct Factor dB/m | Result dBuV/m | Limit dBuV/m | Margin dB | Remark |
|----|---------------|--------------|---------------------|---------------|--------------|-----------|--------|
| 1 | 50.37 | 31.12 | -7.34 | 23.78 | 40.00 | -16.22 | PEAK |
| 2 | 203.63 | 39.64 | -10.40 | 29.24 | 43.50 | -14.26 | PEAK |
| 3 | 285.11 | 48.74 | -6.78 | 41.96 | 46.00 | -4.04 | QP |
| 4 | 302.57 | 45.74 | -6.39 | 39.35 | 46.00 | -6.65 | PEAK |
| 5 | 759.44 | 36.58 | 1.88 | 38.46 | 46.00 | -7.54 | PEAK |
| 6 | 969.93 | 29.52 | 5.06 | 34.58 | 54.00 | -19.42 | PEAK |

| | | | |
|---------------|---------------|-----------|--------------|
| Test Site: | 96602 - WG | Standard: | FCC Part 15C |
| Test Mode: | Transmit Mode | | |
| Polarization: | Vertical | | |
| Remark: | | | |

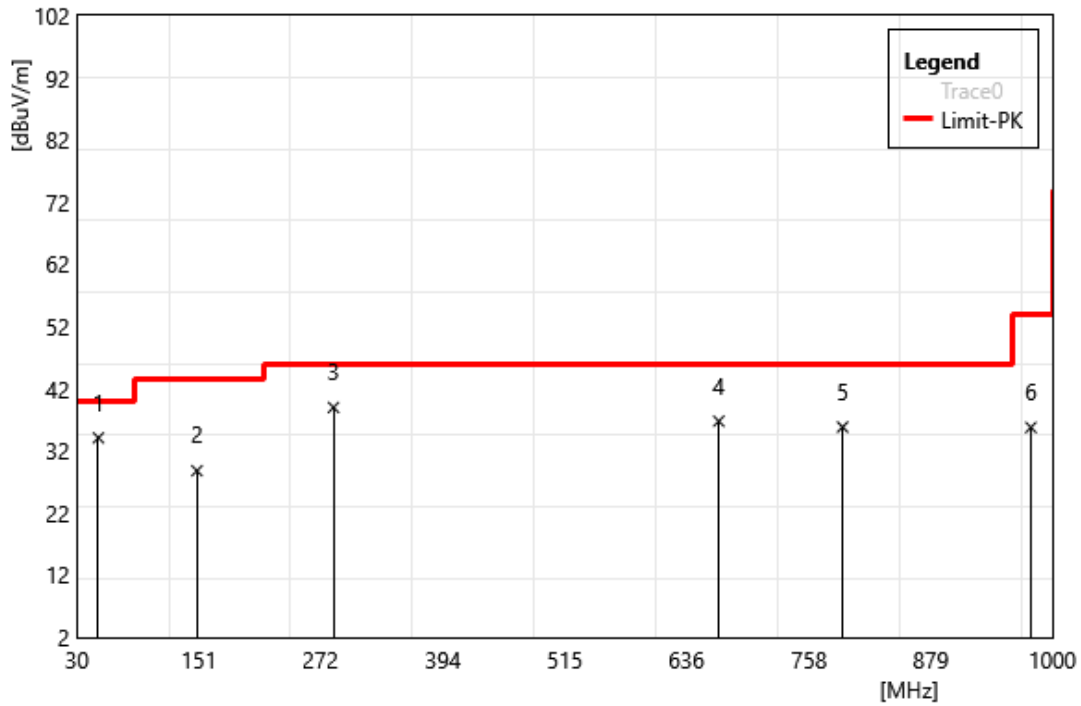

| ID | Frequency MHz | Reading dBuV | Correct Factor dB/m | Result dBuV/m | Limit dBuV/m | Margin dB | Remark |
|----|---------------|--------------|---------------------|---------------|--------------|-----------|--------|
| 1 | 51.34 | 41.39 | -7.30 | 34.09 | 40.00 | -5.91 | PEAK |
| 2 | 149.31 | 36.23 | -7.42 | 28.81 | 43.50 | -14.69 | PEAK |
| 3 | 285.11 | 45.77 | -6.78 | 38.99 | 46.00 | -7.01 | PEAK |
| 4 | 668.26 | 36.83 | -0.05 | 36.78 | 46.00 | -9.22 | PEAK |
| 5 | 791.45 | 33.59 | 2.24 | 35.83 | 46.00 | -10.17 | PEAK |
| 6 | 978.66 | 30.58 | 5.18 | 35.76 | 54.00 | -18.24 | PEAK |

---END---