

FCC 47 CFR PART 15 SUBPART C & INDUSTRY CANADA RSS-210

TEST REPORT

For

Video Intercom

Model No.: TD63-HW / TD53-HW

Trade Name: Verkada

Issued to

FCC: Verkada Inc
405 E. 4th Ave. San Mateo California United States 94401
IC: Verkada, Inc.
405 E. 4th Ave. San Mateo CA 94401 United States Of America
(Excluding The States Of Alaska)

Issued by

Compliance Certification Services Inc.
Wugong Laboratory
No.11, Wugong 6th Rd., Wugu Dist.,
New Taipei City, Taiwan.
Issued Date: October 29, 2024

Unless otherwise stated the results shown in this test report refer only to the sample(s) tested and such sample(s) are retained for 90 days only.

除非另有說明，此報告結果僅對測試之樣品負責，同時此樣品僅保留90天。本報告未經本公司書面許可，不可部份複製。

This document is issued by the Company subject to its General Conditions of Service printed overleaf, available on request or accessible at <http://www.sgs.com.tw/Terms-and-Conditions> and, for electronic format documents, subject to Terms and Conditions for Electronic Documents at <http://www.sgs.com.tw/Terms-and-Conditions>. Attention is drawn to the limitation of liability, indemnification and jurisdiction issues defined therein. Any holder of this document is advised that information contained hereon reflects the Company's findings at the time of its intervention only and within the limits of client's instruction, if any. The Company's sole responsibility is to its Client and this document does not exonerate parties to a transaction from exercising all their rights and obligations under the transaction documents. This document cannot be reproduced, except in full, without prior written approval of the Company. Any unauthorized alteration, forgery or falsification of the content or appearance of this document is unlawful and offenders may be prosecuted to the fullest extent of the law.

Revision History

Rev.	Issue Date	Revisions	Effect Page	Revised By
00	October 22, 2024	Initial Issue	ALL	Peggy Tsai
01	October 28, 2024	See the following Note Rev. (01)	P.4, 8, 9, 21-26	Peggy Tsai
02	October 29, 2024	See the following Note Rev. (02)	P.5	Peggy Tsai

Note:

Rev. (01)

1. Modify Standard in section 1.
2. Modify Description of Test Modes in section 3.4.
3. Modify Test Summary in section 4.
4. Add setting information in section 7.2.

Rev. (02)

1. Modify Remark in section 2.

TABLE OF CONTENTS

1. TEST RESULT CERTIFICATION	4
2. EUT DESCRIPTION	5
3. TEST METHODOLOGY	6
3.1 EUT CONFIGURATION	6
3.2 FCC PART 15.205 RESTRICTED BANDS OF OPERATIONS.....	6
3.3 RSS GEN SECTION 8.10 RESTRICTED BANDS OF OPERATIONS.....	7
3.4 DESCRIPTION OF TEST MODES	8
4. TEST SUMMARY	9
5. INSTRUMENT CALIBRATION	10
5.1 MEASURING INSTRUMENT CALIBRATION	10
5.2 MEASUREMENT EQUIPMENT USED	10
5.3 MEASUREMENT UNCERTAINTY	12
5.4 FACILITIES AND TEST LOCATION	12
6. SETUP OF EQUIPMENT UNDER TEST	13
6.1 SUPPORT EQUIPMENT	13
6.2 SETUP CONFIGURATION OF EUT	14
6.3 TEST PROGRAM.....	14
7. FCC PART 15.209 REQUIREMENTS & RSS-210 REQUIREMENTS	15
7.1 OCCUPIED BANDWIDTH(99%) AND 20 DB BANDWIDTH.....	15
7.2 FUNDAMENTAL AND RADIATED EMISSIONS.....	17
7.3 AC POWERLINE CONDUCTED EMISSIONS	27
APPENDIX A PHOTOGRAPHS OF TEST SETUP	A-1



Project No: TM-2405000384P
Report No.: TMWK2405001752KR

Page: 4 / 31
Rev.: 02

1. TEST RESULT CERTIFICATION

Applicant: FCC: Verkada Inc
405 E. 4th Ave. San Mateo California United States 94401
IC:Verkada, Inc.
405 E. 4th Ave. San Mateo CA 94401 United States Of America
(Excluding The States Of Alaska)

Manufacturer: CHICONY ELECTRONICS (THAILAND) CO., LTD
82 MOO 4 T. THAKHAM A. BANGPAKONG,
CHACHOENSAO, THAILAND 24130

Equipment Under Test: Video Intercom

Trade Name: Verkada

Model No.: TD63-HW / TD53-HW

Date of Test: June 25 ~ September 6, 2024

APPLICABLE STANDARDS	
STANDARD	TEST RESULT
FCC 47 CFR Part 15 209 & RSS-210 Issue 11 and RSS-GEN Issue 5	Compliance
Statements of Conformity	
Determination of compliance is based on the results of the compliance measurement, not taking into account measurement instrumentation uncertainty.	

We hereby certify that:

All test results conform to above mentioned standards.

The above equipment was tested by Compliance Certification Services Inc. The test data, data evaluation, test procedures, and equipment configurations shown in this report were made in accordance with the procedures given in ANSI C63.10: 2013 and the energy emitted by the sample EUT tested as described in this report is in compliance with the requirements of FCC Rules Part15.203, Part15.207, Part15.209. Part15.215.

The test results of this report relate only to the tested sample identified in this report.

Approved by:

Dally Hong
Sr. Engineer

2. EUT DESCRIPTION

Product	Video Intercom
Trade	Verkada
Model No.	TD63-HW / TD53-HW
Model Discrepancy	Difference of the model number (list on this report) is just with or without keypad and corresponding housing. All the other HW and FW features are all the same.
Received Date	May 31, 2024
Power Supply	Power from Poe Adapter. ZYXEL / PoE12-60W I/P: 100-240VAC, 2.0A, 50-60Hz O/P: 56.0VDC, 1.161A, 65.1W
Frequency Range	125kHz
Modulation Technique	ASK
Number of Channels	1 Channel
Antenna Requirement	Type: Coil Antenna Model: F-OW-51-6008-001-00
PMN	TD63-HW: TD63 TD53-HW: TD53
EUT Serial #	TD63-HW: KENW-T9L4-7D7H TD53-HW: LKEJ-6CR7-LNWWW
HW Version	B02
FW Version	v259

Remark:

- For more details, refer to the User's manual of the EUT.
- Disclaimer: Antenna information is provided by the applicant, test results of this report are applicable to the sample EUT received.
- Disclaimer: The variant model numbers are assessed as identical in hardware and software to each other, hence all variants are fully covered by the test results in this test report without further verification test.
- The manufacturer stated that the PoE adapter will provide corresponding current according to the product.

3. TEST METHODOLOGY

The tests documented in this report were performed in accordance with ANSI C63.10: 2013 and FCC CFR 47 Part 15.203, 15.207, 15.209, 15.215.

The tests documented in this report were performed in accordance with IC RSS-210, IC RSS-Gen, and ANSI C63.10: 2013

3.1 EUT CONFIGURATION

The EUT configuration for testing is installed on RF field strength measurement to meet the Commissions requirement and operating in a manner that intends to maximize its emission characteristics in a continuous normal application.

3.2 FCC PART 15.205 RESTRICTED BANDS OF OPERATIONS

(a) Except as shown in other rules, only spurious emissions are permitted in any of the frequency bands listed below:

MHz	MHz	MHz	GHz
0.090 - 0.110	16.42 - 16.423	399.9 - 410	4.5 - 5.15
0.495 - 0.505	16.69475 - 16.69525	608 - 614	5.35 - 5.46
2.1735 - 2.1905	16.80425 - 16.80475	960 - 1240	7.25 - 7.75
4.125 - 4.128	25.5 - 25.67	1300 - 1427	8.025 - 8.5
4.17725 - 4.17775	37.5 - 38.25	1435 - 1626.5	9.0 - 9.2
4.20725 - 4.20775	73 - 74.6	1645.5 - 1646.5	9.3 - 9.5
6.215 - 6.218	74.8 - 75.2	1660 - 1710	10.6 - 12.7
6.26775 - 6.26825	108 - 121.94	1718.8 - 1722.2	13.25 - 13.4
6.31175 - 6.31225	123 - 138	2200 - 2300	14.47 - 14.5
8.291 - 8.294	149.9 - 150.05	2310 - 2390	15.35 - 16.2
8.362 - 8.366	156.52475 -	2483.5 - 2500	17.7 - 21.4
8.37625 - 8.38675	156.52525	2655 - 2900	22.01 - 23.12
8.41425 - 8.41475	156.7 - 156.9	3260 - 3267	23.6 - 24.0
12.29 - 12.293	162.0125 - 167.17	3332 - 3339	31.2 - 31.8
12.51975 - 12.52025	167.72 - 173.2	3345.8 - 3358	36.43 - 36.5
12.57675 - 12.57725	240 - 285	3600 - 4400	(²)
13.36 - 13.41	322 - 335.4		

¹ Until February 1, 1999, this restricted band shall be 0.490-0.510 MHz.

² Above 38.6

(b) Except as provided in paragraphs (d) and (e), the field strength of emissions appearing within these frequency bands shall not exceed the limits shown in Section 15.209. At frequencies equal to or less than 1000 MHz, compliance with the limits in Section 15.209 shall be demonstrated using measurement instrumentation employing a CISPR quasi-peak detector. Above 1000 MHz, compliance with the emission limits in Section 15.209 shall be demonstrated based on the average value of the measured emissions. The provisions in Section 15.35 apply to these measurements.

3.3 RSS GEN SECTION 8.10 RESTRICTED BANDS OF OPERATIONS

Restricted frequency bands, identified in table 7, are designated primarily for safety-of-life services (distress calling and certain aeronautical activities), certain satellite downlinks, radio astronomy and some government uses. Except where otherwise indicated, the following conditions related to the restricted frequency bands apply:

- (a) The transmit frequency, including fundamental components of modulation, of licence-exempt radio apparatus shall not fall within the restricted frequency bands listed in table 7 except for apparatus compliant with RSS-287, Emergency Position Indicating Radio Beacons (EPIRB), Emergency Locator Transmitters (ELT), Personal Locator Beacons (PLB), and Maritime Survivor Locator Devices (MSLD).
- (b) Unwanted emissions that fall into restricted frequency bands listed in table 7 shall comply with the limits specified in table 5 and table 6.
- (c) Unwanted emissions that do not fall within the restricted frequency bands listed in table 7 shall comply either with the limits specified in the applicable RSS or with those specified in table 5 and table 6.

Table 7 – Restricted frequency bands ^{Note 1}			
MHz	MHz	MHz	GHz
0.090 - 0.110	16.42 - 16.423	608 - 614	9.0 - 9.2
0.495 - 0.505	16.69475 - 16.69525	960 - 1427	9.3 - 9.5
2.1735 - 2.1905	16.80425 - 16.80475	1435 - 1626.5	10.6 - 12.7
3.020 - 3.026	25.5 - 25.67	1645.5 - 1646.5	13.25 - 13.4
4.125 - 4.128	37.5 - 38.25	1660 - 1710	14.47 - 14.5
4.17725 - 4.17775	73 - 74.6	1718.8 - 1722.2	15.35 - 16.2
4.20725 - 4.20775	74.8 - 75.2	2200 - 2300	17.7 - 21.4
5.677 - 5.683	108 - 138	2310 - 2390	22.01 - 23.12
6.215 - 6.218	149.9 - 150.05	2483.5 - 2500	23.6 - 24.0
6.26775 - 6.26825	156.52475 -	2655 - 2900	31.2 - 31.8
6.31175 - 6.31225	156.52525	3260 - 3267	36.43 - 36.5
8.291 - 8.294	156.7 - 156.9	3332 - 3339	Above 38.6
8.362 - 8.366	162.0125 - 167.17	3345.8 - 3358	
8.37625 - 8.38675	167.72 - 173.2	3500 - 4400	
8.41425 - 8.41475	240 - 285	4500 - 5150	
12.29 - 12.293	322 - 335.4	5350 - 5460	
12.51975 - 12.52025	399.9 - 410	7250 - 7750	
12.57675 - 12.57725		8025 - 8500	
13.36 - 13.41			

Note 1: Certain frequency bands listed in table 7 and in bands above 38.6 GHz are designated for licence-exempt applications. These frequency bands and the requirements that apply to related devices are set out in the 200 and 300 series of RSSs.

3.4 DESCRIPTION OF TEST MODES

The EUT had been tested under engineering test mode condition and the EUT staying in continuous transmitting mode.

3.4.1 The worst mode of measurement

AC Power Line Conducted Emission	
Test Condition	AC Power line conducted emission for line and neutral
Power supply Mode	Mode 1: EUT Power by PoE Adapter(TD63-HW) Mode 2: EUT Power by PoE Adapter(TD53-HW)
Worst Mode	<input checked="" type="checkbox"/> Mode 1 <input type="checkbox"/> Mode 2 <input type="checkbox"/> Mode 3 <input type="checkbox"/> Mode 4

Radiated Emission Measurement Below 1G	
Test Condition	Radiated Emission Below 1G
Power supply Mode	Mode 1: EUT power by PoE Adapter (TD63-HW) Mode 2: EUT power by PoE Adapter (TD53-HW)
Worst Mode	<input checked="" type="checkbox"/> Mode 1 <input type="checkbox"/> Mode 2 <input type="checkbox"/> Mode 3 <input type="checkbox"/> Mode 4

Remark:

1. The worst mode was record in this test report.
2. AC power line conducted emission and for below 1G radiation emission were performed the EUT transmit at the highest output power channel as worse case.
3. EUT pre-scanned in three axis ,X,Y, Z and two polarity, for radiated measurement. The worst case(Y-Plane) were recorded in this report

4. TEST SUMMARY

FCC Standard Sec.	IC Standard Sec.	Chapter	Test Item	Result
15.203	RSS-GEN Sec. 6.8	2	Antenna Requirement	Pass
15.215	RSS-GEN Sec 6.7	7.1	Occupied Bandwidth (99%) and 20dB Bandwidth	Pass
15.209 15.205	Sec 8.3, RSS-GEN Sec 8.9 / 8.10	7.2	Radiated Emissions	Pass
15.207	RSS-GEN Sec. 8.8	7.3	AC Power-line Conducted Emission	Pass

5. INSTRUMENT CALIBRATION

5.1 MEASURING INSTRUMENT CALIBRATION

The measuring equipment, which was utilized in performing the tests documented herein, has been calibrated in accordance with the manufacturer's recommendations for utilizing calibration equipment, which is traceable to recognized national standards.

5.2 MEASUREMENT EQUIPMENT USED

Equipment Used for Emissions Measurement

Conducted FCC/IC/NCC(All)					
Name of Equipment	Manufacturer	Model	Serial Number	Calibration Date	Calibration Due
Loop Probe	LANGER EMV-TECHNIK	RF-R 50-1	02-2644	2024-01-02	2025-01-01
EXA Signal Analyzer	Keysight	N9030B	MY62291089	2023-10-13	2024-10-12
Software	N/A				

966A Radiated Below 30MHz					
Name of Equipment	Manufacturer	Model	Serial Number	Calibration Date	Calibration Due
Signal Analyzer	KEYSIGHT	N9010A	MY52220817	2024-03-15	2025-03-14
Active Loop Antenna	SCHWARZBECK	FMZB 1513-60	1513-60-028	2023-12-13	2024-12-12
Thermo-Hygro Meter	WISEWIND	1206	D07	2023-12-07	2024-12-06
Bi-Log Antenna	Sunol Sciences	JB3	A030105	2023-08-08	2024-08-07
				2024-07-12	2025-07-11
Preamplifier	EMEC	EM330	060609	2024-02-21	2025-02-20
Cable	Huber+Suhner	104PEA	20995+21000+182330	2024-02-21	2025-02-20
Turn Table	CCS	CC-T-1F	N/A	N.C.R	N.C.R
Controller	CCS	CC-C-1F	N/A	N.C.R	N.C.R
Antenna Tower	CCS	CC-A-1F	N/A	N.C.R	N.C.R
Software	e3 V9-210616c				

Remark:

1. Each piece of equipment is scheduled for calibration once a year.
2. N.C.R. = No Calibration Request.

AC Mains Conduction					
Name of Equipment	Manufacturer	Model	Serial Number	Calibration Date	Calibration Due
EMI Test Receiver	R&S	ESCI	100064	2024-06-14	2025-06-13
LISN	TESEQ	LN2-16N	22012	2024-02-29	2025-02-27
Cable	Woken	SFL402	185A	2024-07-08	2025-07-07
Software	e3 V6-110812				

Remark:

1. Each piece of equipment is scheduled for calibration once a year.
2. N.C.R. = No Calibration Request.

5.3 MEASUREMENT UNCERTAINTY

PARAMETER	UNCERTAINTY
AC Powerline Conducted Emission	± 2.213 dB
Channel Bandwidth	± 2.7%
Radiated Emission_9kHz-30MHz	± 3.761 dB
Radiated Emission_30MHz-200MHz	± 3.473 dB
Radiated Emission_200MHz-1GHz	± 3.946 dB

Remark: This uncertainty represents an expanded uncertainty expressed at approximately the 95% confidence level using a coverage factor of k=2.

5.4 FACILITIES AND TEST LOCATION

All measurement facilities used to collect the measurement data are located at No.11, Wugong 6th Rd., Wugu Dist., New Taipei City, Taiwan.

CAB identifier: TW1309

Test site	Test Engineer	Remark
AC Conduction Room	Ben Yang	-
Radiation	Tony Chao	-
RF Conducted	Marco Chan	-

Remark: The lab has been recognized as the FCC accredited lab under the KDB 974614 D01 and is listed in the FCC public Access Link (PAL) database, FCC Registration No. :444940, the FCC Designation No.:TW1309

6. SETUP OF EQUIPMENT UNDER TEST

6.1 SUPPORT EQUIPMENT

EUT Accessories Equipment						
No.	Equipment	Brand	Model	Series No.	FCC ID	IC
	N/A					

Support Equipment (Conducted)					
No.	Equipment	Brand	Model	Series No.	FCC ID
1	NB(B)	Lenovo	T470	N/A	N/A
2	Adapter	Lenovo	ADLX45DLC3A	N/A	N/A
3	PoE Injector	Zyxel	PoE12-60W	S212L41486914	N/A
4	RJ45	LINKOMM	E530529	N/A	N/A
5	RJ45	LINKOMM	E530529	N/A	N/A
A	Card	N/A	N/A	N/A	N/A

Support Equipment (RSE)					
No.	Equipment	Brand	Model	Series No.	FCC ID
1	NB(D)	Lenovo	ThinkPad X260	N/A	N/A
2	Adapter	Lenovo	ADLX45DLC3A	N/A	N/A
3	PoE Injector	Zyxel	PoE12-60W	S212L41486914	N/A
4	Ethernet Cable	Rasto	R-PCC004	N/A	N/A
5	Ethernet Cable	Atake	AC6-FL10	N/A	N/A
A	Card	N/A	N/A	N/A	N/A

Support Equipment (Conduction)					
No.	Equipment	Brand	Model	Series No.	FCC ID
1	NB(D)	Lenovo	ThinkPad X260	N/A	N/A
2	PoE Injector	Zyxel	PoE12-60W	S212L41486914	N/A
3	Ethernet Cable	Rasto	R-PCC004	N/A	N/A
4	Ethernet Cable	Atake	AC6-FL10	N/A	N/A
A	Card	N/A	N/A	N/A	N/A

6.2 SETUP CONFIGURATION OF EUT

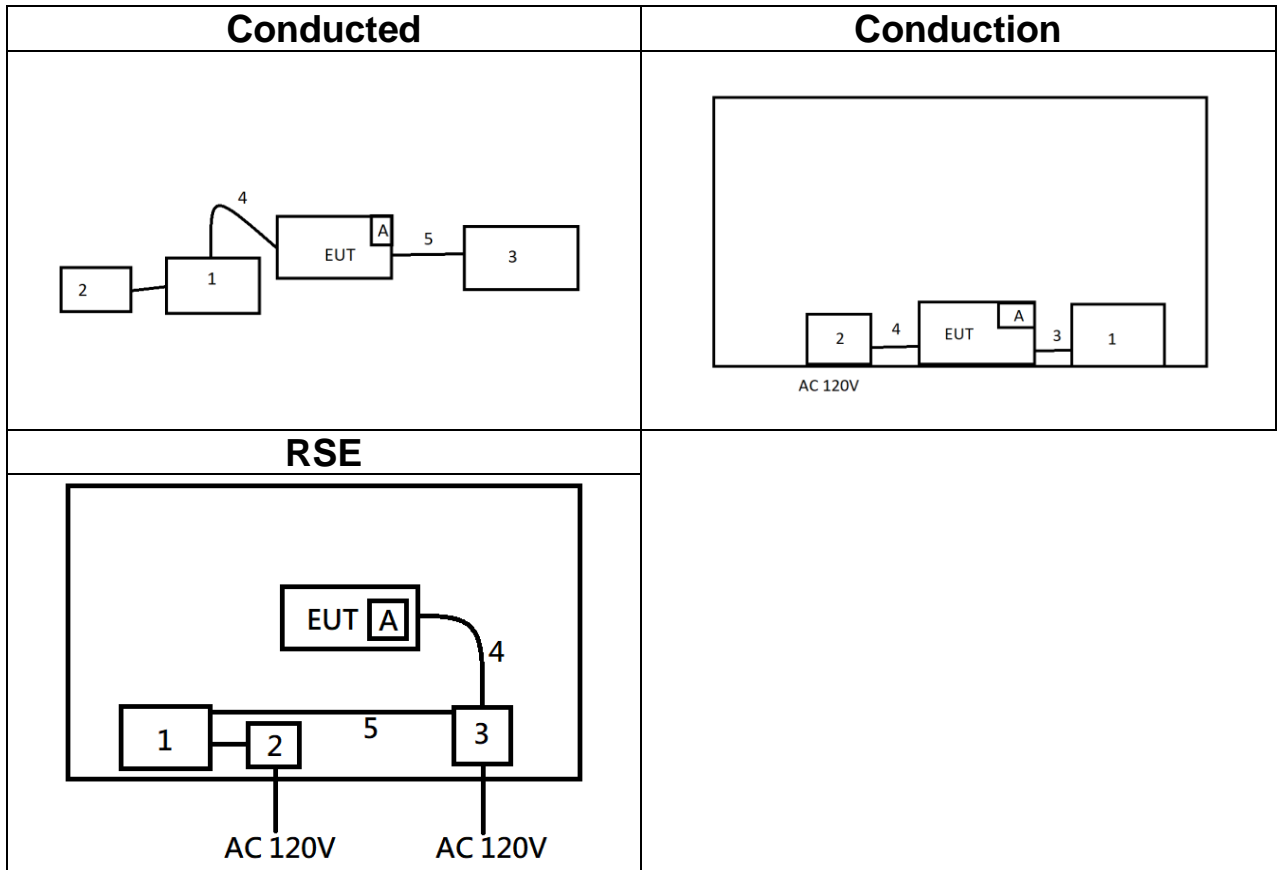

6.3 TEST PROGRAM

This EUT uses "Tera term v4.73" software and setup command to set the frequency, modulation, and power to allow the sample to continuously transmit.

7. FCC PART 15.209 REQUIREMENTS & RSS-210 REQUIREMENTS

7.1 OCCUPIED BANDWIDTH(99%) AND 20 DB BANDWIDTH

TEST CONFIGURATION

Refer to section 6.2.

TEST PROCEDURE

According to FCC Part 15.215 (c) ,Intentional radiators operating under the alternative provisions to the general emission limits, as contained in §§15.217 through 15.257 and in subpart E of this part, must be designed to ensure that the 20 dB bandwidth of the emission, or whatever bandwidth may otherwise be specified in the specific rule section under which the equipment operates, is contained within the frequency band designated in the rule section under which the equipment is operated.

For ISED, RSS-GEN, 6.7 Occupied bandwidth (or 99% emission bandwidth) and x dB bandwidth

The occupied bandwidth or the “99% emission bandwidth” is defined as the frequency range between two points, one above and the other below the carrier frequency, within which 99% of the total transmitted power of the fundamental transmitted emission is contained. The occupied bandwidth shall be reported for all equipment in addition to the specified bandwidth required in the applicable RSSs.

In some cases, the “x dB bandwidth” is required, which is defined as the frequency range between two points, one at the lowest frequency below and one at the highest frequency above the carrier frequency, at which the maximum power level of the transmitted emission is attenuated x dB below the maximum in-band power level of the modulated signal, where the two points are on the outskirts of the in-band emission.

1. Place the EUT on the table and set it in the transmitting mode.
2. Remove the antenna from the EUT and then connect a low loss RF cable from the antenna port to the spectrum analyzer.
3. Set the spectrum analyzer as RBW & VBW (RBW) shall be in the range of 1% to 5% of the actual occupied / x dB bandwidth (VBW) shall not be smaller than three times the RBW value.
4. Record the max. reading.

TEST RESULTS

Compliance

TEST DATA

Temperature: 24.1°C **Humidity:** 56% RH
Tested by: Marco Chan **Test Date:** June 27, 2024

Occupied Channel Bandwidth Result						
Modulation Mode	Frequency (Fc)	99% Bandwidth (kHz)	F _{SL} (kHz)	F _L BW (kHz)	F _H at 20dB BW (kHz)	F _{SH} at 20dB BW (kHz)
Full charging loading	121.450	2.307	120.297	122.604	120.098	122.801

Note

Because the measured signal adjusting the RBW per C63.10 would not be practical since measured bandwidth will always follow the RBW and the result will be approximately twice ~ three the RBW.

Test Plot

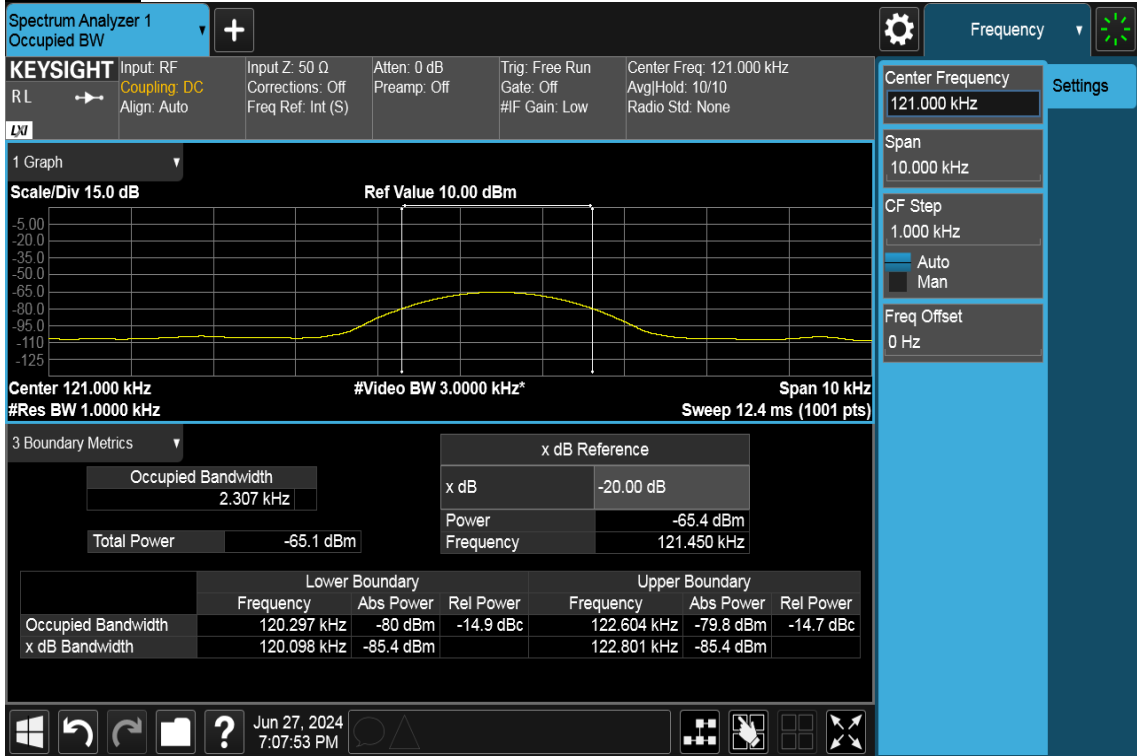

7.2 FUNDAMENTAL AND RADIATED EMISSIONS

LIMIT

According to FCC PART 15.209(a), except as provided elsewhere in this Subpart, the emissions from an intentional radiator shall not exceed the field strength levels specified in the following table:

Frequency (MHz)	Field Strength ($\mu\text{V/m}$ at meter)	Measurement Distance (meter)
0.009 – 0.490	2400 / F (kHz)	300
0.490 – 1.705	24000 / F (kHz)	30
1.705 – 30.0	30	30
30 - 88	100**	3
88-216	150**	3
216-960	200**	3
Above 960	500	3

** Except as provided in paragraph (g), fundamental emissions from intentional radiators operating under this Section shall not be located in the frequency bands 54-72 MHz, 76-88 MHz, 174-216 MHz or 470-806 MHz. However, operation within these frequency bands is permitted under other sections of this Part, e.g., Sections 15.231 and 15.241.

Above 30MHz

Frequency (MHz)	Field Strength		Measurement Distance (meter)
	($\mu\text{V/m}$)	(dB $\mu\text{V/m}$)	
30-88	100	40.0	3
88-216	150	43.5	3
216-960	200	46.0	3
Above 960	500	54.0	3

According to RSS-210, Section 7.3 and RSS-GEN Sec. 8.9 §B.6 Transmitters whose wanted and unwanted emissions fall within the general field strength limits specified in RSS-Gen may operate licence-exempt in any of the frequency bands, other than the restricted frequency bands listed in RSS-Gen and the TV bands 54-72 MHz, 76-88 MHz, 174-216 MHz and 470-602 MHz, and shall be certified under RSS-210. Under no circumstances shall the level of any unwanted emissions exceed the level of the fundamental emissions.

Below 30 MHz

Frequency	Magnetic field strength (H-Field) (µA/m)	Measurement Distance (metres)
9-490 kHz ^{Note 1}	6.37/F (F in kHz)	300
490-1,705 kHz	63.7/F (F in kHz)	30
1.705-30 MHz	0.08	30

Note 1: The emission limits for the ranges 9-90 kHz and 110-490 kHz are based on measurements employing a linear average detector.

Above 30 MHz

Frequency	Field strength (µV/m at 3 m)
30-88	100
88-216	150
216-960	200
Above 960	500

Test Configuration

9kHz ~ 30MHz

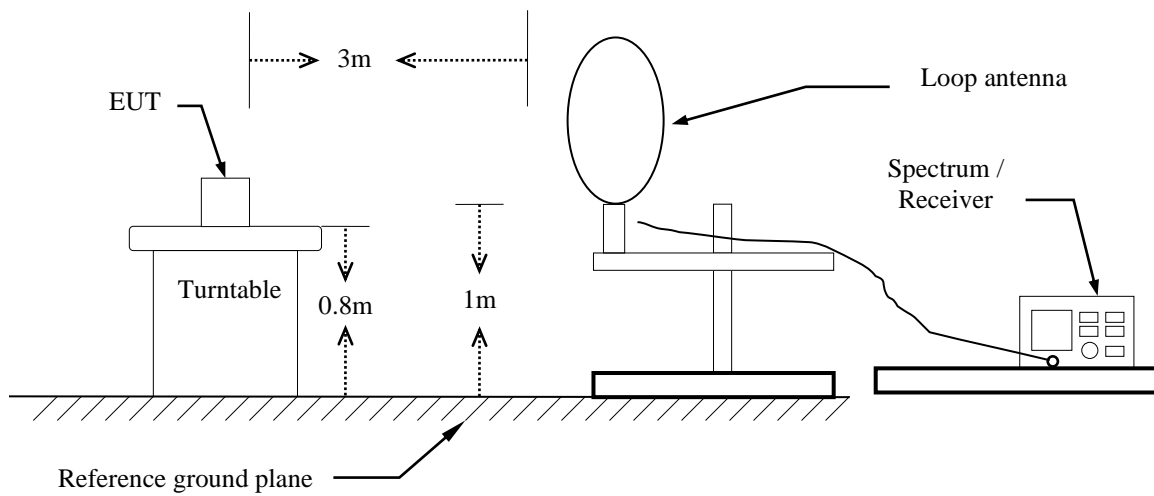

30MHz ~ 1GHz

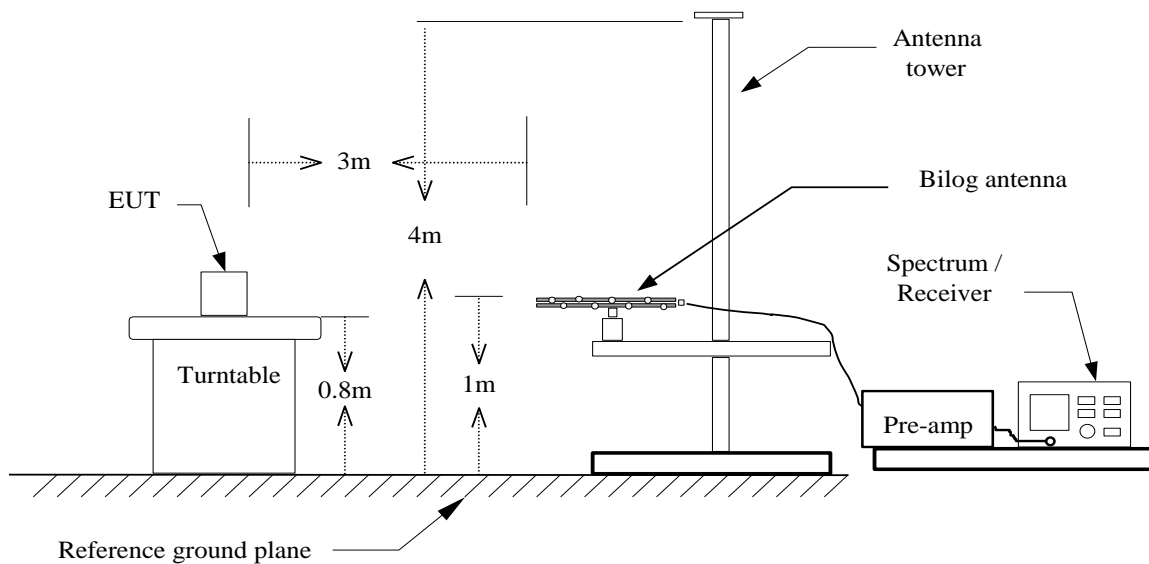

TEST PROCEDURE

For 9kHz ~ 30MHz

1. The EUT is placed on a turntable, which is 0.8m above ground plane.
2. The turntable shall be rotated for 360 degrees to determine the position of maximum emission level.
3. EUT is set 3m away from the receiving antenna, The lower edge of the loop shall be 1 m above the ground then to find out the highest emissions.
4. Maximum procedure was performed on the six highest emissions to ensure EUT compliance.
5. Set the spectrum analyzer in the following setting as:
9KHz-490KHz : RBW=200Hz / VBW=1kHz / Sweep=AUTO
490KHz-30MHz : RBW=10kHz / VBW=30kHz / Sweep=AUTO
6. Repeat above procedures until the measurements for all frequencies are complete.

For 30MHz ~ 1GHz

1. The EUT is placed on a turntable, which is 0.8m above ground plane.
2. The turntable shall be rotated for 360 degrees to determine the position of maximum emission level.
3. EUT is set 3m away from the receiving antenna, which is varied from 1m to find out the highest emissions.
4. Maximum procedure was performed on the six highest emissions to ensure EUT compliance.
5. And also, each emission was to be maximized by changing the polarization of receiving antenna both horizontal and vertical.
6. Set the spectrum analyzer in the following setting as:
RBW=100kHz / VBW=300kHz / Sweep=AUTO
7. Repeat above procedures until the measurements for all frequencies are complete.

Remark :

Although these tests were performed other than open area test site, adequate comparison measurements were confirmed against 30 m open are test site. Therefore sufficient tests were made to demonstrate that the alternative site produces results that correlate with the ones of tests made in an open field based on KDB 414788.

Fundamental Strength

Project No	:TM-2405000384P	Test Date	:2024-07-09
Operation Band	:RFID	Temp./Humi.	:24.6/57
Frequency	:125 KHz	Antenna Pol.	:HORIZONTAL
Operation Mode	:Main	Engineer	:Tony Chao
EUT Pol	:E1	Test Chamber	: 966A
Setting	:Default		

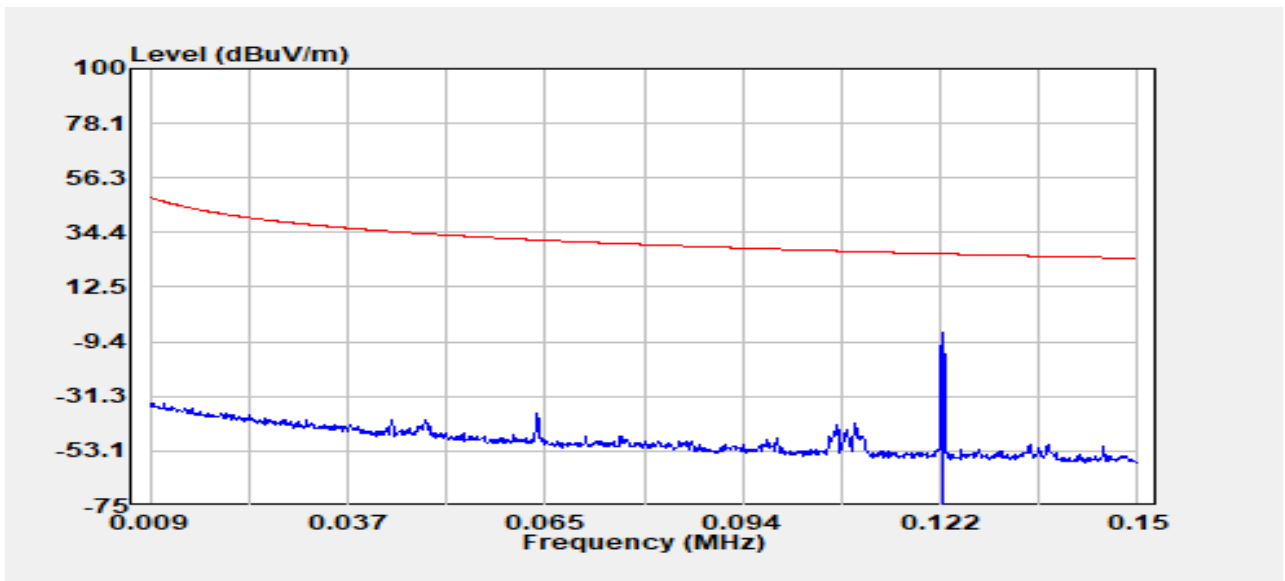

Freq.	Detector Mode	Spectrum Read Level @3m	Factor @3m	Actual FS @3m	Factor @30m&300m	Actual FS @30m&300m	Limit	Margin
MHz	PK/QP/AV	dBμV	dB	dBμV/m	dB	dBμV/m	dBμV/m	dB
0.122	Peak	60.61	13.75	74.36	-80.00	-5.64	25.87	-31.51

Remark:

1. Radiated emissions measured were made with an instrument using peak/quasi-peak/average detector mode.
2. Measurements above show only up to 6 maximum emissions noted, or would be lesser, with " N/A " remark, if no specific emissions from the EUT are recorded (ie: margin>20dB from the applicable limit) and considered that's already beyond the background noise floor.
3. Margin (dB) = Result (dBuV/m) – Limit (dBuV/m).
4. Result=Read level+Factor@3m-Distance factor
5. Distance factor=40log(30m/3m)
6. Factor=antenna factor+cable loss

Project No: TM-2405000384P
 Report No.: TMWK2405001752KR

Page: 22 / 31
 Rev.: 02

Project No :TM-2405000384P
 Operation Band :RFID
 Frequency :125 KHz
 Operation Mode :Main
 EUT Pol :E1
 Setting :Default

Test Date :2024-07-09
 Temp./Humi. :24.6/57
 Antenna Pol. :VERTICAL
 Engineer :Tony Chao
 Test Chamber : 966A

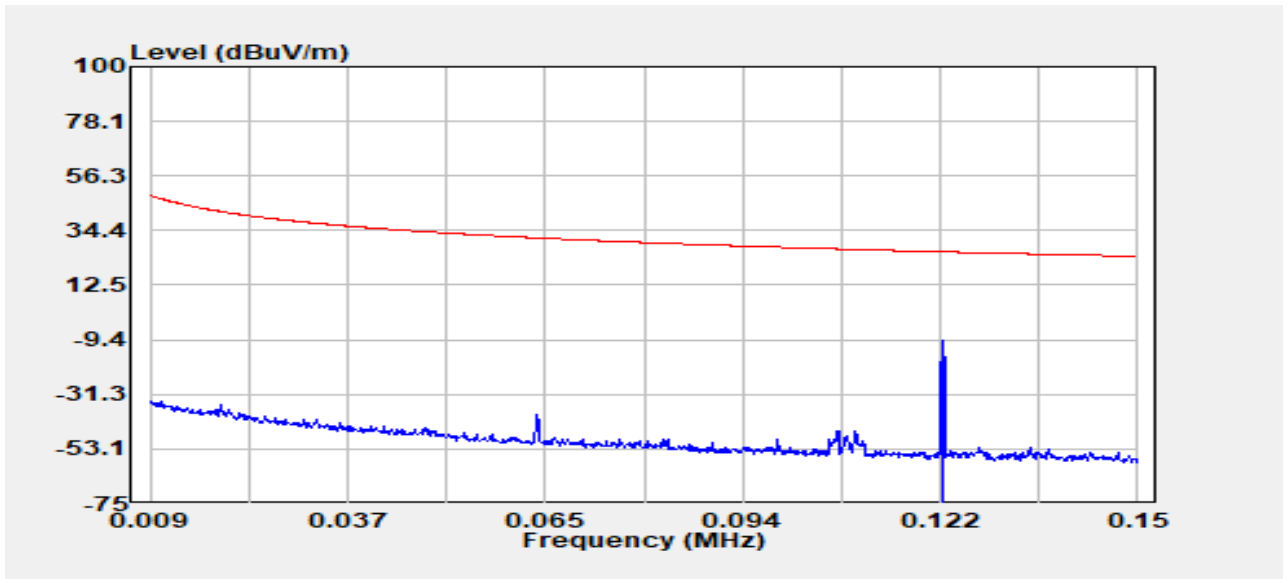

Freq. MHz	Detector Mode	Spectrum Read Level @3m dB μ V	Factor @3m dB	Actual FS @3m dBUV/m	Factor @30m&300m dB	Actual FS @30m&300m dBUV/m	Limit dBUV/m	Margin dB
0.122	Peak	56.70	13.75	70.45	-80.00	-9.55	25.86	-35.42

Remark:

1. Radiated emissions measured were made with an instrument using peak/quasi-peak/average detector mode.
2. Measurements above show only up to 6 maximum emissions noted, or would be lesser, with " N/A " remark, if no specific emissions from the EUT are recorded (ie: margin>20dB from the applicable limit) and considered that's already beyond the background noise floor.
3. Margin (dB) = Result (dBUV/m) – Limit (dBUV/m).
4. Result=Read level+Factor@3m-Distance factor
5. Distance factor=40log(30m/3m)
6. Factor=antenna factor+cable loss

Project No	:TM-2405000384P	Test Date	:2024-07-09
Operation Band	:RFID	Temp./Humi.	:24.6/57
Frequency	:125 KHz	Antenna Pol.	:Ground
Operation Mode	:Main	Engineer	:Tony Chao
EUT Pol	:E1	Test Chamber	: 966A
Setting	:Default		

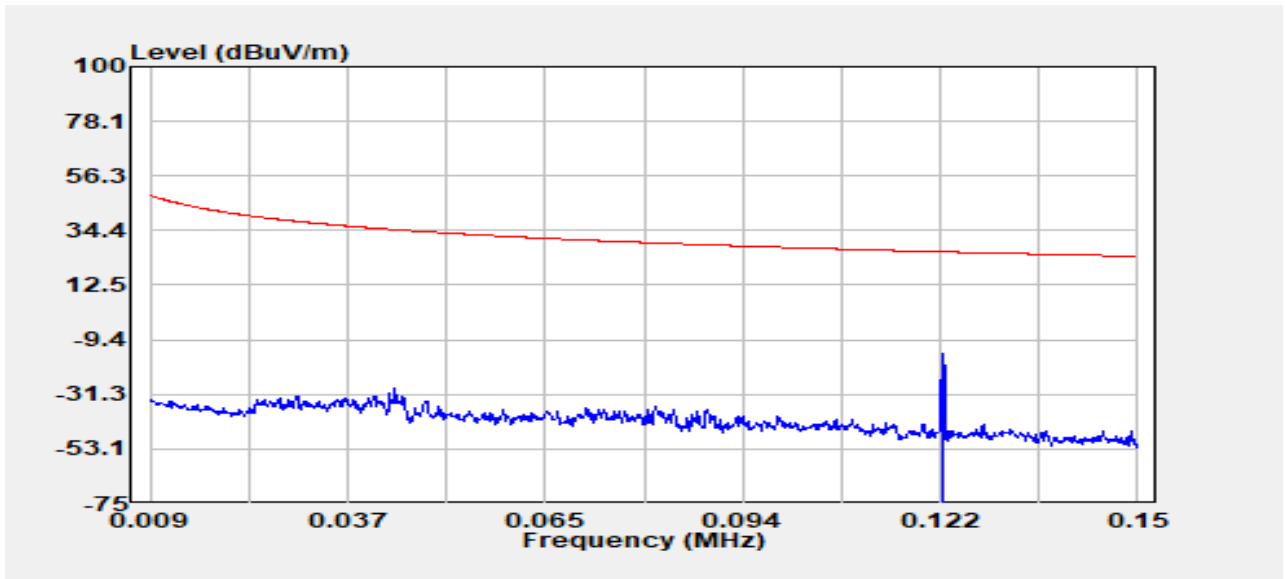

Freq. MHz	Detector Mode	Spectrum Read Level @3m dBμV	Factor @3m dB	Actual FS @3m dBUV/m	Factor @30m&300m dB	Actual FS @30m&300m dBUV/m	Limit dBμV/m	Margin dB
0.122	Peak	51.63	13.75	65.38	-80.00	-14.62	25.86	-40.48

Remark:

1. Radiated emissions measured were made with an instrument using peak/quasi-peak/average detector mode.
2. Measurements above show only up to 6 maximum emissions noted, or would be lesser, with " N/A " remark, if no specific emissions from the EUT are recorded (ie: margin>20dB from the applicable limit) and considered that's already beyond the background noise floor.
3. Margin (dB) = Result (dBUV/m) – Limit (dBUV/m).
4. Result=Read level+Factor@3m-Distance factor
5. Distance factor=40log(30m/3m)
6. Factor=antenna factor+cable loss

9kHz ~ 30MHz

Project No	:TM-2405000384P	Test Date	:2024-07-09
Operation Band	:RFID	Temp./Humi.	:24.6/57
Frequency	:125 KHz	Antenna Pol.	:HORIZONTAL
Operation Mode	:TX	Engineer	:Tony Chao
EUT Pol	:E1	Test Chamber	: 966A
Setting	:Default		

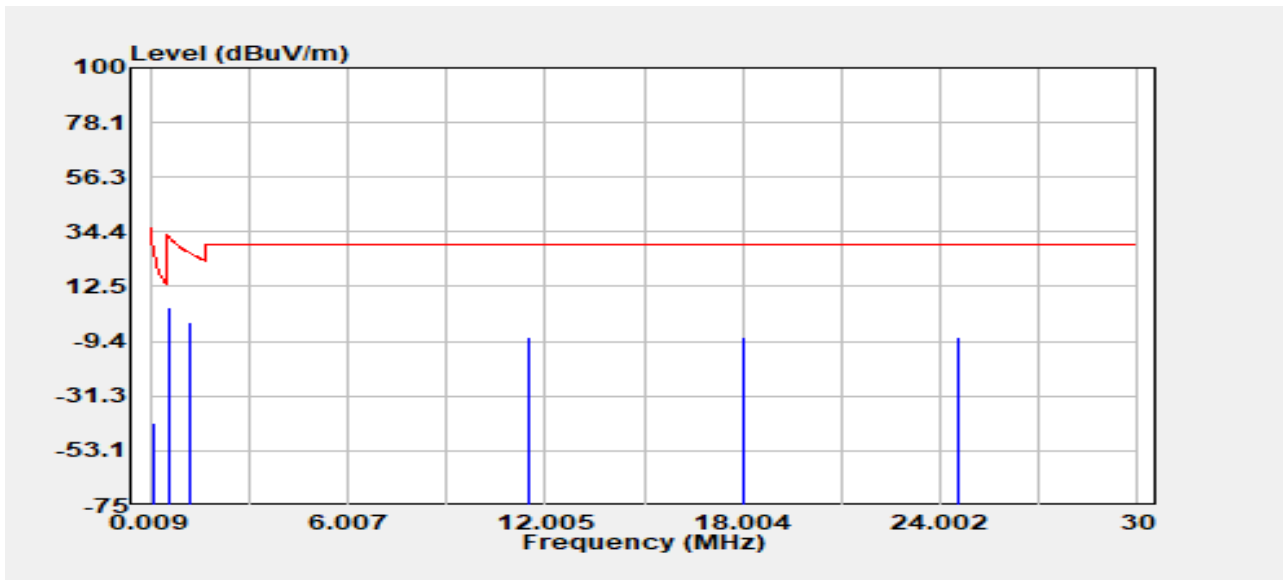

Freq. MHz	Detector Mode	Spectrum Read Level @3m dBuV	Factor @3m dB	Actual FS @3m dBuV/m	Factor @30m&300m dB	Actual FS @30m&300m dBuV/m	Limit dBuV/m	Margin dB
0.110	Peak	24.28	13.64	37.93	-80.00	-42.07	26.80	-68.87
0.618	Peak	29.65	14.51	44.17	-40.00	4.17	31.79	-27.62
1.235	Peak	23.88	14.68	38.56	-40.00	-1.44	25.77	-27.22
11.493	Peak	14.94	17.13	32.06	-40.00	-7.94	29.54	-37.48
18.020	Peak	14.43	17.73	32.16	-40.00	-7.84	29.54	-37.38
24.577	Peak	15.38	16.99	32.37	-40.00	-7.63	29.54	-37.17

Remark:

- 9kHz to 490kHz Limit(@3m) = 2400(F/kHz)
 490kHz to 1.705MHz Limit (@3m) = 2400(F/kHz)
 1.705MHz to 30MHz Limit (@3m) = 29.54
- Distance factor=40log(300m/3m)@9-490kHz ; 40log(30m/3m)@490kHz-30MHz
- Result=Read level+Factor@3m-Distance factor

30MHz ~ 1GHz

Project No	:TM-2405000384P	Test Date	:2024-09-06
Operation Band	:RFID	Temp./Humi.	:24.6/57
Frequency	:125 KHz	Antenna Pol.	:VERTICAL
Operation Mode	:TX	Engineer	:Tony Chao
EUT Pol	:E1	Test Chamber	: 966A
Setting	:Default		

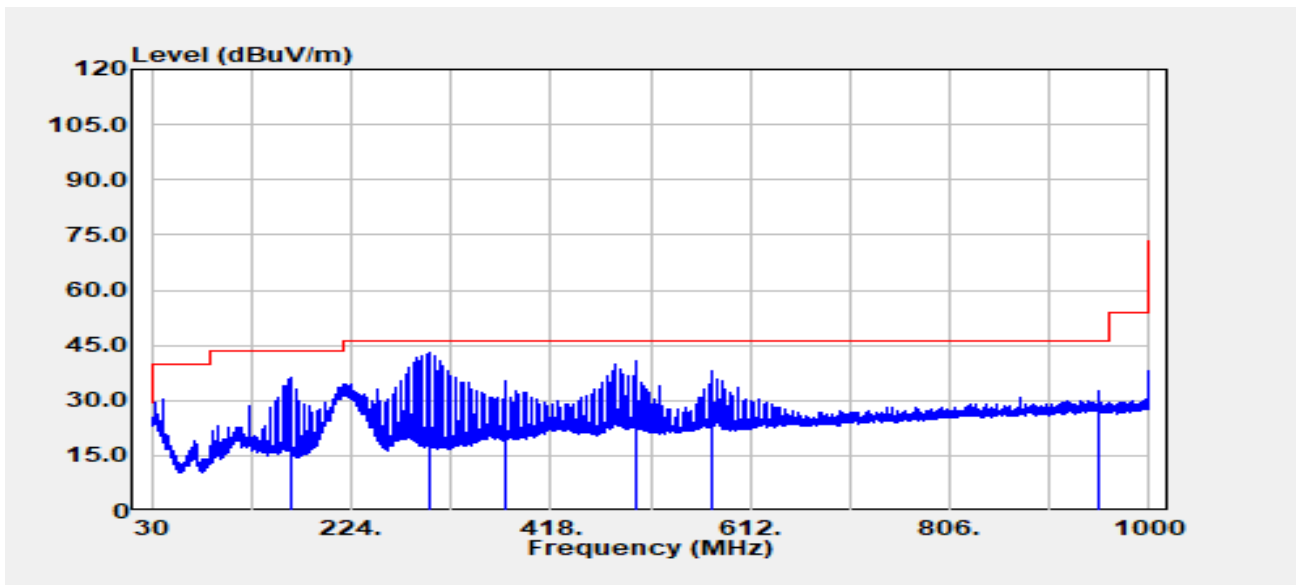

Freq. MHz	Detector Mode PK/QP/AV	Spectrum Read Level dB μ V	Factor dB	Actual FS dB μ V/m	Limit dB μ V/m	Margin dB
165.92	Peak	47.65	-11.50	36.15	43.50	-7.35
301.12	Peak	52.21	-9.31	42.90	46.00	-3.10
374.96	Peak	42.86	-7.64	35.22	46.00	-10.78
499.97	Peak	44.95	-4.40	40.55	46.00	-5.45
575.02	Peak	41.43	-3.19	38.24	46.00	-7.76
950.05	Peak	29.83	2.58	32.41	46.00	-13.59

Project No: TM-2405000384P
 Report No.: TMWK2405001752KR

Page: 26 / 31
 Rev.: 02

Project No	:TM-2405000384P	Test Date	:2024-09-06
Operation Band	:RFID	Temp./Humi.	:24.6/57
Frequency	:125 KHz	Antenna Pol.	:HORIZONTAL
Operation Mode	:TX	Engineer	:Tony Chao
EUT Pol	:E1	Test Chamber	: 966A
Setting	:Default		

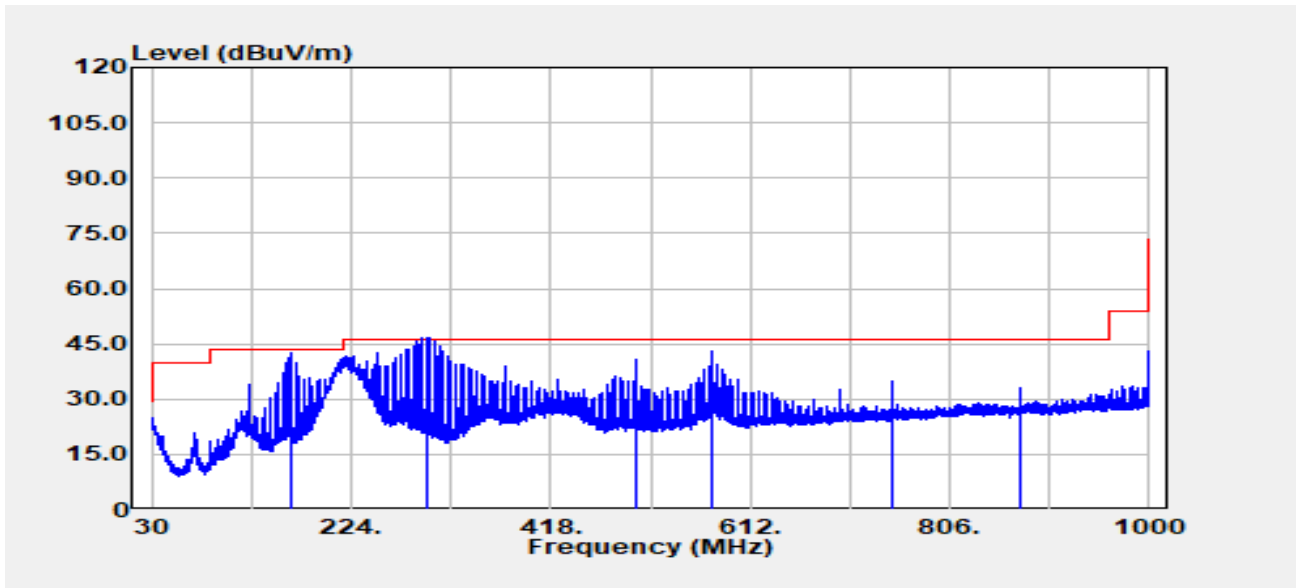

Freq. MHz	Detector Mode PK/QP/AV	Spectrum Read Level dB μ V	Factor dB	Actual FS dB μ V/m	Limit dB μ V/m	Margin dB
165.92	Peak	54.28	-11.50	42.77	43.50	-0.73
296.99	QP	55.04	-9.43	45.61	46.00	-0.39
499.97	Peak	45.03	-4.40	40.63	46.00	-5.37
575.02	Peak	46.06	-3.19	42.87	46.00	-3.13
749.98	Peak	35.00	-0.25	34.75	46.00	-11.25
874.99	Peak	31.36	1.50	32.86	46.00	-13.14

7.3 AC POWERLINE CONDUCTED EMISSIONS

LIMIT

According to §15.207(a) and RSS-Gen §8.8 for an intentional radiator that is designed to be connected to the public utility (AC) power line, the radio frequency voltage that is conducted back onto the AC power line on any frequency or frequencies within the band 150 kHz to 30 MHz shall not exceed the limits in the following table, as measured using a 50 µH/50 ohms line impedance stabilization network (LISN). Compliance with the provisions of this paragraph shall be based on the measurement of the radio frequency voltage between each power line and ground at the power terminal. The lower limit applies at the boundary between the frequency ranges.

Frequency Range (MHz)	Limits (dBµV)	
	Quasi-peak	Average
0.15 to 0.50	66 to 56*	56 to 46*
0.50 to 5	56	46
5 to 30	60	50

* Decreases with the logarithm of the frequency.

TEST PROCEDURE

Test method Refer as ANSI 63.10:2013 clause 6.2,

1. The EUT was placed on a table, which is 0.8m above ground plane.
2. Maximum procedure was performed on the six highest emissions to ensure EUT compliance.
3. Repeat above procedures until all frequency measured were complete

TEST RESULTS

The initial step in collecting conducted data is a spectrum analyzer peak scan of the measurement range. Significant peaks are then marked as shown on the following data page, and these signals are then quasi-peaked and Average measurement records.

Project No: TM-2405000384P
 Report No.: TMWK2405001752KR

Page: 28 / 31
 Rev.: 02

Project No : TM-2405000384P
 Operation Mode : RFID
 Test Chamber : Conduction
 Probe : LINE
 Note :

Test Date : 2024-07-10
 Temp./Humi. : 23.4°C / 54%
 Engineer : Ben Yang
 Test Voltage : AC 120V/60Hz

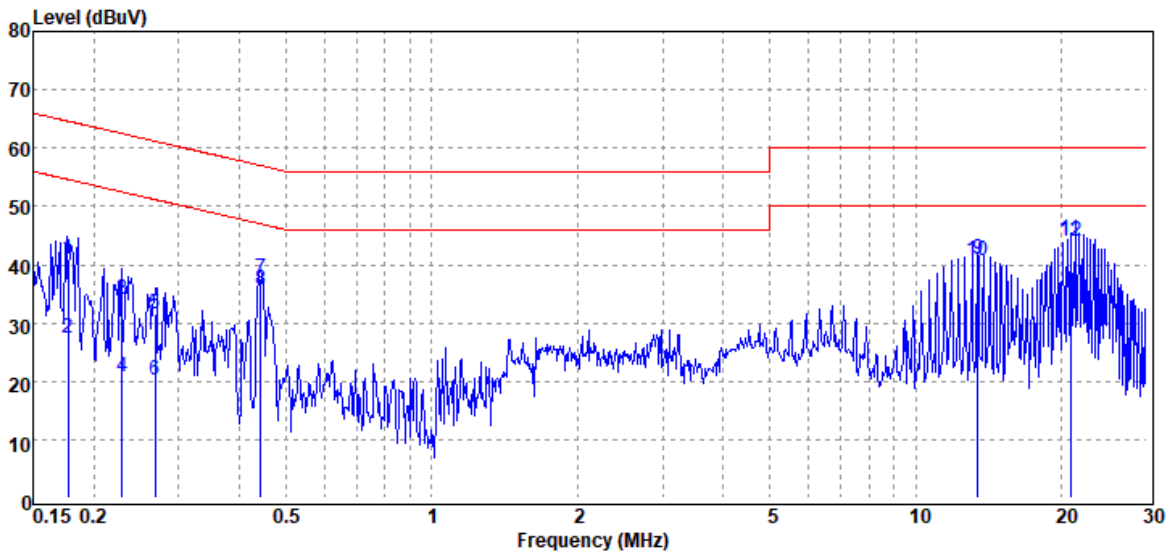

Freq. MHz	Detector Mode PK/QP/AV	Spectrum Read Level dB μ V	Factor dB	Actual FS dB μ V	Limit dB μ V	Margin dB
0.178	QP	40.77	0.28	41.05	64.60	-23.55
0.178	Average	27.07	0.28	27.35	54.60	-27.25
0.229	QP	33.63	0.39	34.02	62.49	-28.47
0.229	Average	20.38	0.39	20.77	52.49	-31.72
0.268	QP	31.28	0.39	31.67	61.17	-29.50
0.268	Average	19.89	0.39	20.28	51.17	-30.89
0.444	QP	37.23	0.38	37.61	56.99	-19.38
0.444	Average	35.32	0.38	35.70	46.99	-11.29
13.417	QP	40.44	0.41	40.85	60.00	-19.15
13.417	Average	40.34	0.41	40.75	50.00	-9.25
20.915	QP	43.72	0.49	44.21	60.00	-15.79
20.915	Average	43.58	0.49	44.07	50.00	-5.93

Note: 1. Actual FS= Spectrum Read Level + Factor

Note: 2. Margin= Actual FS - Limit

Project No: TM-2405000384P
 Report No.: TMWK2405001752KR

Page: 29 / 31
 Rev.: 02

Project No : TM-2405000384P
 Operation Mode : RFID
 Test Chamber : Conduction
 Probe : NEUTRAL
 Note :

Test Date : 2024-07-10
 Temp./Humi. : 23.4°C / 54%
 Engineer : Ben Yang
 Test Voltage : AC 120V/60Hz

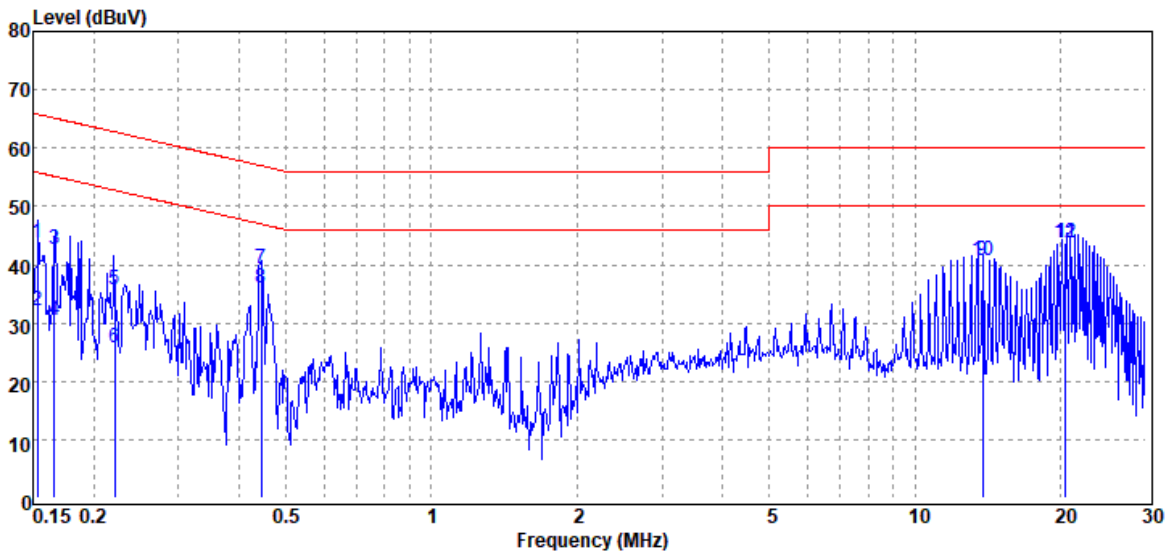

Freq. MHz	Detector Mode PK/QP/AV	Spectrum Read Level dB μ V	Factor dB	Actual FS dB μ V	Limit dB μ V	Margin dB
0.153	QP	43.63	0.12	43.75	65.82	-22.07
0.153	Average	31.93	0.12	32.05	55.82	-23.77
0.166	QP	42.48	0.19	42.67	65.16	-22.49
0.166	Average	30.27	0.19	30.46	55.16	-24.70
0.221	QP	35.26	0.36	35.62	62.78	-27.16
0.221	Average	25.27	0.36	25.63	52.78	-27.15
0.445	QP	38.83	0.35	39.18	56.96	-17.78
0.445	Average	35.75	0.35	36.10	46.96	-10.86
13.813	QP	40.42	0.38	40.80	60.00	-19.20
13.813	Average	40.40	0.38	40.78	50.00	-9.22
20.522	QP	43.28	0.45	43.73	60.00	-16.27
20.522	Average	43.21	0.45	43.66	50.00	-6.34

Note: 1. Actual FS= Spectrum Read Level + Factor

Note: 2. Margin= Actual FS - Limit

Project No: TM-2405000384P
 Report No.: TMWK2405001752KR

Page: 30 / 31
 Rev.: 02

Project No : TM-2405000384P
 Operation Mode : RFID
 Test Chamber : Conduction
 Probe : LINE
 Note :

Test Date : 2024-07-10
 Temp./Humi. : 23.4°C / 54%
 Engineer : Ben Yang
 Test Voltage : AC 230V/60Hz

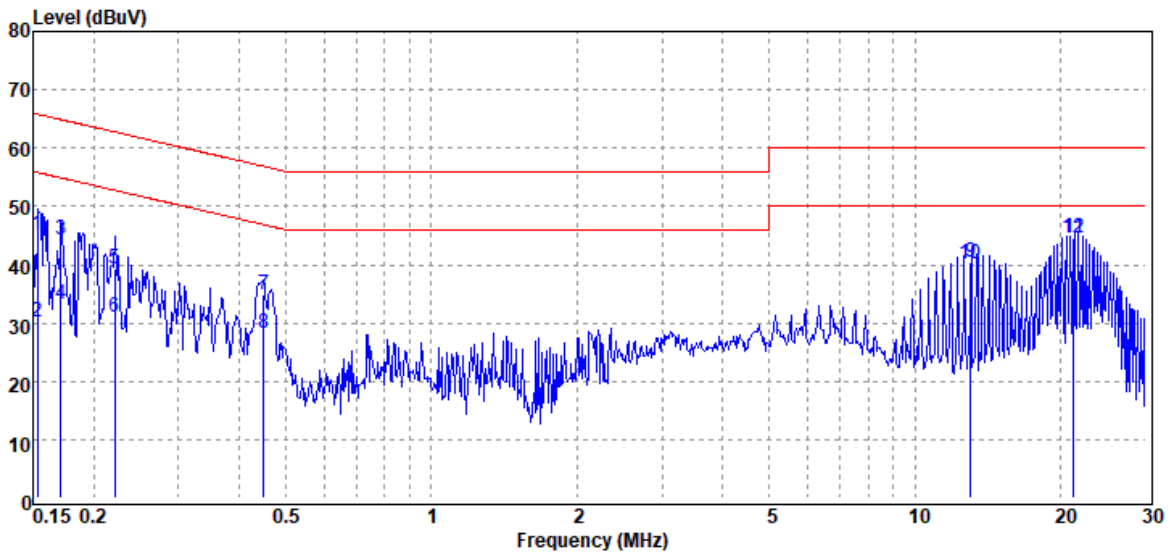

Freq. MHz	Detector Mode PK/QP/AV	Spectrum Read Level dB μ V	Factor dB	Actual FS dB μ V	Limit dB μ V	Margin dB
0.153	QP	44.88	0.14	45.02	65.81	-20.79
0.153	Average	30.10	0.14	30.24	55.81	-25.57
0.172	QP	44.15	0.25	44.40	64.89	-20.49
0.172	Average	33.08	0.25	33.33	54.89	-21.56
0.221	QP	38.90	0.39	39.29	62.77	-23.48
0.221	Average	30.62	0.39	31.01	52.77	-21.76
0.449	QP	34.60	0.38	34.98	56.89	-21.91
0.449	Average	27.85	0.38	28.23	46.89	-18.66
13.020	QP	39.91	0.40	40.31	60.00	-19.69
13.020	Average	39.77	0.40	40.17	50.00	-9.83
21.308	QP	44.08	0.51	44.59	60.00	-15.41
21.308	Average	44.00	0.51	44.51	50.00	-5.49

Note: 1. Actual FS= Spectrum Read Level + Factor

Note: 2. Margin= Actual FS - Limit

Project No: TM-2405000384P
 Report No.: TMWK2405001752KR

Page: 31 / 31
 Rev.: 02

Project No : TM-2405000384P
 Operation Mode : RFID
 Test Chamber : Conduction
 Probe : NEUTRAL
 Note :

Test Date : 2024-07-10
 Temp./Humi. : 23.4°C / 54%
 Engineer : Ben Yang
 Test Voltage : AC 230V/60Hz

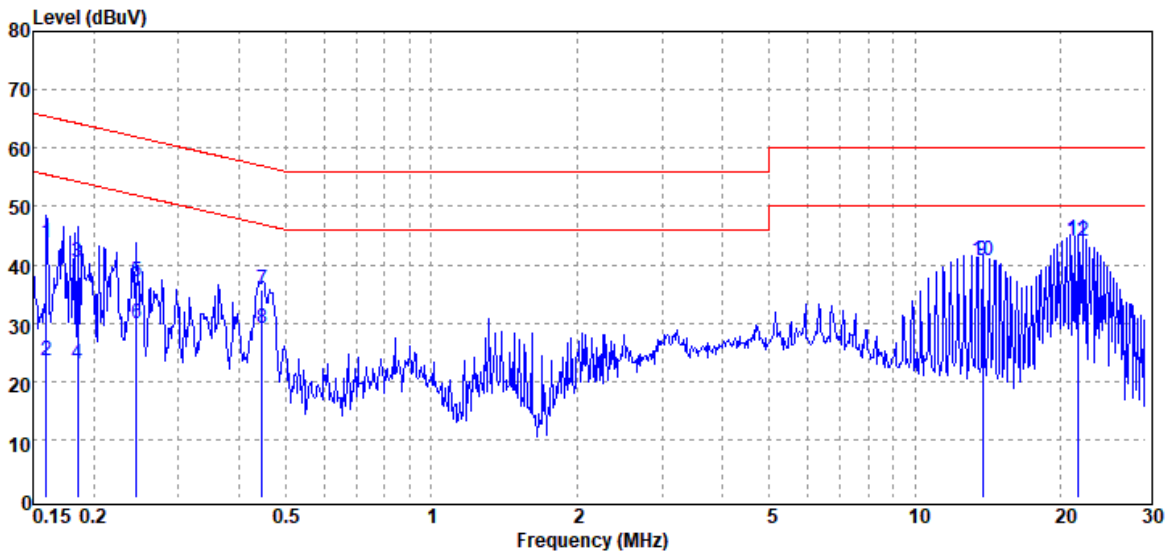

Freq. MHz	Detector Mode PK/QP/AV	Spectrum Read Level dBμV	Factor dB	Actual FS dBμV	Limit dBμV	Margin dB
0.160	QP	43.50	0.16	43.66	65.46	-21.80
0.160	Average	23.36	0.16	23.52	55.46	-31.94
0.186	QP	40.22	0.30	40.52	64.22	-23.70
0.186	Average	22.67	0.30	22.97	54.22	-31.25
0.245	QP	36.75	0.36	37.11	61.92	-24.81
0.245	Average	29.62	0.36	29.98	51.92	-21.94
0.447	QP	35.44	0.35	35.79	56.93	-21.14
0.447	Average	28.79	0.35	29.14	46.93	-17.79
13.814	QP	40.36	0.38	40.74	60.00	-19.26
13.814	Average	40.31	0.38	40.69	50.00	-9.31
21.705	QP	43.71	0.47	44.18	60.00	-15.82
21.705	Average	43.56	0.47	44.03	50.00	-5.97

Note: 1. Actual FS= Spectrum Read Level + Factor

Note: 2. Margin= Actual FS - Limit

- End of Test Report -