

FCC Test Report

Applicant : SHENZHEN RUIBOSI ELECTRONIC CO., LTD.

Address : 5F,Block B,Shabian Industrial Park,Sanwei,
Xixiang,Bao'an,Shenzhen,China

Product Name : 4G Solar Trail Camera

Report Date : Aug. 15, 2023



Shenzhen Anbotek Compliance Laboratory Limited

Shenzhen Anbotek Compliance Laboratory Limited

Address: 1/F., Building D, Sogood Science and Technology Park, Sanwei Community,
Hangcheng Street, Bao'an District, Shenzhen, Guangdong, China.
Tel: (86) 0755-26066440 Fax: (86) 0755-26014772 Email: service@anbotek.com

Code: AB-RF-05-b



Hotline

400-003-0500

www.anbotek.com.cn



Contents

1. General Information	6
1.1. Client Information	6
1.2. Description of Device (EUT)	6
1.3. Auxiliary Equipment Used During Test	8
1.4. Operation State	8
1.5. Environmental Conditions	10
1.6. Test Equipment List	10
1.7. Measurement Uncertainty	11
1.8. Description of Test Facility	11
2. Summary of Test	12
2.1. Summary of test result	12
3. Conducted Output Power Test	14
3.1. Test Standard and Limit	14
3.2. Test Setup	14
3.3. Test Procedure	14
3.4. Test Data	14
4. Peak-Average Ratio	15
4.1. Test Standard and Limit	15
4.2. Test Setup	15
4.3. Test Procedure	15
4.4. Test Data	15
5. Modulation Characteristic	16
6. 99% Occupied Bandwidth & 26 dB Bandwidth	17
6.1. Test Standard and Limit	17
6.2. Test Setup	17
6.3. Test Procedure	17
6.4. Test Data	17
7. Conducted Spurious Emission	18
7.1. Test Standard and Limit	18
7.2. Test Setup	18
7.3. Test Procedure	18
7.4. Test Data	19
8. Band Edge	20
8.1. Test Standard and Limit	20
8.2. Test Setup	21
8.3. Test Procedure	21
8.4. Test Data	21



9. Radiated Spurious Emission.....	22
9.1. Test Standard and Limit.....	22
9.2. Test Setup.....	22
9.3. Test Procedure.....	23
9.4. Test Data.....	24
10. ERP and EIRP.....	44
10.1. Test Standard and Limit.....	44
10.2. Test Setup.....	44
10.3. Test Procedure.....	45
10.4. Test Data.....	46
11. Frequency stability VS Voltage measurement.....	51
11.1. Test Standard and Limit.....	51
11.2. Test Setup.....	51
11.3. Test Procedure.....	51
11.4. Test Data.....	51
12. Frequency stability VS Temperature measurement.....	52
12.1. Test Standard and Limit.....	52
12.2. Test Setup.....	52
12.3. Test Procedure.....	52
12.4. Test Data.....	52
APPENDIX I -- TEST SETUP PHOTOGRAPH.....	53
APPENDIX II -- EXTERNAL PHOTOGRAPH.....	53
APPENDIX III -- INTERNAL PHOTOGRAPH.....	53



TEST REPORT

Applicant : SHENZHEN RUIBOSI ELECTRONIC CO., LTD.
Manufacturer : SHENZHEN RUIBOSI ELECTRONIC CO., LTD.
Product Name : 4G Solar Trail Camera
Model No. : RBX-H10
Trade Mark : N/A
Rating(s) : Input: 5V $\overline{=}$ 2A (with 3.7V, 3*2600mAh battery inside)

Test Standard(s) : **FCC PART 2, FCC Part 22(H), FCC Part 24(E), FCC Part 27(C),
FCC PART 90 (S)**

Test Method(s) : **ANSI C63.26-2015
KDB 971168 D01 Power Meas License Digital Systems v03r01**

The device described above is tested by Shenzhen Anbotek Compliance Laboratory Limited to determine the maximum emission levels emanating from the device and the severe levels of the device can endure and its performance criterion. The measurement results are contained in this test report and Shenzhen Anbotek Compliance Laboratory Limited is assumed full of responsibility for the accuracy and completeness of these measurements. Also, this report shows that the EUT (Equipment Under Test) is technically compliant with the FCC Part 22, FCC Part 24, FCC Part 27, FCC Part 90 requirements.

This report applies to above tested sample only and shall not be reproduced in part without written approval of Shenzhen Anbotek Compliance Laboratory Limited.

Date of Receipt : Jun. 20, 2023
Date of Test : Jun. 20 ~ Jul. 03, 2023

Prepared by :

Nian Xiu Chen

(Nianxiu Chen)

Approved & Authorized Signer :

Kingkong Jin

(Kingkong Jin)



Revision History

Report Version	Description	Issued Date
R00	Original Issue.	Aug. 15, 2023



1. General Information

1.1. Client Information

Applicant	:	SHENZHEN RUIBOSI ELECTRONIC CO., LTD.
Address	:	5F,Block B,Shabian Industrial Park,Sanwei, Xixiang,Bao'an,Shenzhen,China
Manufacturer	:	SHENZHEN RUIBOSI ELECTRONIC CO., LTD.
Address	:	5F,Block B,Shabian Industrial Park,Sanwei, Xixiang,Bao'an,Shenzhen,China
Factory	:	SHENZHEN RUIBOSI ELECTRONIC CO., LTD.
Address	:	5F,Block B,Shabian Industrial Park,Sanwei, Xixiang,Bao'an,Shenzhen,China

1.2. Description of Device (EUT)

Product Name	:	4G Solar Trail Camera
Model No.	:	RBX-H10
Trade Mark	:	N/A
Test Power Supply	:	DC 3.7V Battery inside
Test Sample No.	:	1-2-1(Normal Sample), 1-2-2(Engineering Sample)
Adapter	:	N/A
RF Specification		
Support Band	:	<input checked="" type="checkbox"/> FDD Band 2 <input checked="" type="checkbox"/> FDD Band 4 <input checked="" type="checkbox"/> FDD Band 5 <input type="checkbox"/> FDD Band 7 <input checked="" type="checkbox"/> FDD Band 12 <input checked="" type="checkbox"/> FDD Band 13 <input type="checkbox"/> FDD Band 14 <input type="checkbox"/> FDD Band 17 <input checked="" type="checkbox"/> FDD Band 25 <input checked="" type="checkbox"/> FDD Band 26 <input type="checkbox"/> TDD Band 38 <input type="checkbox"/> TDD Band 41 <input type="checkbox"/> FDD Band 66 <input type="checkbox"/> FDD Band 71
Transmit Frequency	:	FDD Band 2: 1850.7~1909.3MHz FDD Band 4: 1710.7~1754.3MHz FDD Band 5: 824.7~848.3MHz FDD Band 12: 699.7~715.3MHz FDD Band 13: 779.5~784.5MHz FDD Band 25: 1850.7~1914.3MHz FDD Band 26: 814.7~848.3MHz
Receive Frequency	:	FDD Band 2: 1930.7~1989.3MHz FDD Band 4: 2110.7~2154.3MHz FDD Band 5: 869.7~893.3MHz FDD Band 12: 729.7~745.3MHz FDD Band 13: 748.5~753.5MHz FDD Band 25: 1930.7~1994.3MHz



	FDD Band 26: 859.7~893.3MHz
Modulation Type	: QPSK, 16QAM
Power Class	: Class 3
Antenna Type	: External Antenna
Antenna Gain(Peak):	FDD Band 2: 3 dBi (Provided by customer) FDD Band 4: 3 dBi (Provided by customer) FDD Band 5: 3 dBi (Provided by customer) FDD Band 12: 3 dBi (Provided by customer) FDD Band 13: 3 dBi (Provided by customer) FDD Band 25: 3 dBi (Provided by customer) FDD Band 26: 3 dBi (Provided by customer)
Remark: 1) For a more detailed features description, please refer to the manufacturer's specifications or the User's Manual.	



1.3. Auxiliary Equipment Used During Test

Description	Rating(s)
--	--

1.4. Operation State

Test frequency list:

Band	Frequency (MHz)						
	Test Frequency ID	Bandwidth [MHz]	N _{UL}	Frequency of Uplink [MHz]	N _{DL}	Frequency of Downlink [MHz]	
FDD Band 2	Low Range	1.4	18607	1850.7	607	1930.7	
		3	18615	1851.5	615	1931.5	
		5	18625	1852.5	625	1932.5	
		10	18650	1855	650	1935	
		15 [1]	18675	1857.5	675	1937.5	
	Mid Range	20 [1]	18700	1860	700	1940	
		1.4/3/5/10/15 [1]/20 [1]	18900	1880	900	1960	
	High Range	1.4	19193	1909.3	1193	1989.3	
		3	19185	1908.5	1185	1988.5	
		5	19175	1907.5	1175	1987.5	
		10	19150	1905	1150	1985	
		15 [1]	19125	1902.5	1125	1982.5	
	20 [1]	19100	1900	1100	1980		
	FDD Band 4	Low Range	1.4	19957	1710.7	1957	2110.7
			3	19965	1711.5	1965	2111.5
5			19975	1712.5	1975	2112.5	
10			20000	1715	2000	2115	
15			20025	1717.5	2025	2117.5	
Mid Range		20	20050	1720	2050	2120	
		1.4/3/5/10/15/20	20175	1732.5	2175	2132.5	
High Range		1.4	20393	1754.3	2393	2154.3	
		3	20385	1753.5	2385	2153.5	
		5	20375	1752.5	2375	2152.5	
		10	20350	1750	2350	2150	
		15	20325	1747.5	2325	2147.5	
20		20300	1745	2300	2145		
FDD Band 5		Low Range	1.4	20407	824.7	2407	869.7
			3	20415	825.5	2415	870.5
	5		20425	826.5	2425	871.5	
	10 [1]		20450	829	2450	874	
	Mid Range	1.4/3/5/10 [1]	20525	836.5	2525	881.5	
		1.4	20643	848.3	2643	893.3	
	High Range	3	20635	847.5	2635	892.5	
		5	20625	846.5	2625	891.5	
		10 [1]	20600	844	2600	889	



Test Frequency ID	Bandwidth [MHz]	N _{UL}	Frequency of Uplink [MHz]	N _{DL}	Frequency of Downlink [MHz]
FDD Band 12	1.4	23017	699.7	5017	729.7
	3	23025	700.5	5025	730.5
	5 ^[1]	23035	701.5	5035	731.5
	10 ^[1]	23060	704	5060	734
	1.4/3 5 ^[1] /10 ^[1]	23095	707.5	5095	737.5
High Range	1.4	23173	715.3	5173	745.3
	3	23165	714.5	5165	744.5
	5 ^[1]	23155	713.5	5155	743.5
	10 ^[1]	23130	711	5130	741

Test Frequency ID	Bandwidth [MHz]	N _{UL}	Frequency of Uplink [MHz]	N _{DL}	Frequency of Downlink [MHz]
FDD Band 13	5 ^[1]	23205	779.5	5205	748.5
	10 ^[1]	23230	782	5230	751
Mid Range	5 ^[1] /10 ^[1]	23230	782	5230	751
High Range	5 ^[1]	23255	784.5	5255	753.5
	10 ^[1]	23230	782	5230	751

Test Frequency ID	Bandwidth [MHz]	N _{UL}	Frequency of Uplink [MHz]	N _{DL}	Frequency of Downlink [MHz]
FDD Band 25	1.4	26047	1850.7	8047	1930.7
	3	26055	1851.5	8055	1931.5
	5	26065	1852.5	8065	1932.5
	10	26090	1855	8090	1935
	15 ^[1]	26115	1857.5	8115	1937.5
	20 ^[1]	26140	1860	8140	1940
Mid Range	1.4/3/5/10 15 ^[1] /20 ^[1]	26365	1882.5	8365	1962.5
High Range	1.4	26683	1914.3	8683	1994.3
	3	26675	1913.5	8675	1993.5
	5	26665	1912.5	8665	1992.5
	10	26640	1910	8640	1990
	15 ^[1]	26615	1907.5	8615	1987.5
	20 ^[1]	26590	1905	8590	1985

Test Frequency ID	Bandwidth [MHz]	N _{UL}	Frequency of Uplink [MHz]	N _{DL}	Frequency of Downlink [MHz]
FDD Band 26 (814-824MHz)	1.4	26697	814.7	8697	859.7
	3	26705	815.5	8705	860.5
	5	26715	816.5	8715	861.5
Mid Range	1.4/3/5/10	26740	819	8740	864
High Range	1.4	26783	823.3	8783	868.3
	3	26775	822.5	8775	867.5
	5	26765	821.5	8765	866.5
NOTE 1: Bandwidth for which a relaxation of the specified UE receiver sensitivity requirement (TS 36/101 [27] Clause 7.3) is allowed.					

Test Frequency ID	Bandwidth [MHz]	N _{UL}	Frequency of Uplink [MHz]	N _{DL}	Frequency of Downlink [MHz]
FDD Band 26 (824-849MHz)	1.4	26797	824.7	8797	869.7
	3	26805	825.5	8805	870.5
	5	26815	826.5	8815	871.5
	10 ^[1]	26840	829	8840	874
	15 ^[1]	26865	831.5	8865	876.5
Mid Range	1.4/3/5/10 ^[1] 15 ^[1]	26915	836.5	8915	881.5
High Range	1.4	27033	848.3	9033	893.3
	3	27025	847.5	9025	892.5
	5	27015	846.5	9015	891.5
	10 ^[1]	26990	844	8990	889
	15 ^[1]	26965	841.5	8965	886.5
NOTE 1: Bandwidth for which a relaxation of the specified UE receiver sensitivity requirement (TS 36.101 [27] Clause 7.3) is allowed.					



1.5. Environmental Conditions

Temperature range:	21-25°C
Humidity range:	40-75%
Pressure range:	86-106kPa

1.6. Test Equipment List

Item	Equipment	Manufacturer	Model No.	Serial No.	Last Cal.	Cal. Interval
1.	EMI Preamplifier	SKET Electronic	LNPA-0118G-45	SKET-PA-002	Oct. 13, 2022	1 Year
2.	EMI Test Receiver	Rohde & Schwarz	ESR26	101481	Oct. 23, 2022	1 Year
3.	Double Ridged Horn Antenna	SCHWARZBECK	BBHA 9120D	02555	Oct. 16, 2022	3 Year
4.	Bilog Broadband Antenna	Schwarzbeck	VULB9163	VULB 9163-289	Oct. 23, 2022	2 Year
5.	Pre-amplifier	SONOMA	310N	186860	Oct. 23, 2022	1 Year
6.	EMI Test Software EZ-EMC	SHURPLE	N/A	N/A	N/A	N/A
7.	MXA Spectrum Analysis	Agilent	N9020A	MY51170037	Oct. 13, 2022	1 Year
8.	MXG RF Vector Signal Generator	Agilent	N5182A	MY48180656	Oct. 13, 2022	1 Year
9.	DC Power Supply	LW	TPR-6420D	374470	Oct. 22, 2022	1 Year
10.	Constant Temperature Humidity Chamber	ZHONGJIAN	ZJ-KHWS80B	N/A	Oct. 19, 2022	1 Year
11.	Wideband Radio Communication Tester	Rohde & Schwarz	CMW 500	167336	Oct. 13, 2022	1 Year
12.	High-Pass Filter	CDKMV	ZHPF-BM1100 -4000-0730	B2015094550	Oct. 22, 2022	1 Year
13.	High-Pass Filter	CDKMV	ZHPF-M3.5 -18G-3834	1307006523	Oct. 22, 2022	1 Year
14.	Bilog Broadband Antenna	SCHWARZBECK	VULB 9163	01109	Oct. 16, 2022	3 Year
15.	Double Ridged Horn Antenna	Chengyi Electronics Co., Ltd.	GTH-0118	351600	Nov. 02, 2022	2 Year



1.7. Measurement Uncertainty

Maximum measurement uncertainty

Parameter	Uncertainty
RF output power, conducted	±1,5 dB
Power Spectral Density, conducted	±3 dB
Unwanted Emissions, conducted	±3 dB
All emissions, radiated	±6 dB
Temperature	±1 °C
Humidity	±5 %
DC and low frequency voltages	±3 %
Time	±5 %
Confidence interval: 95%. Confidence factor:k=2	

1.8. Description of Test Facility

The test facility is recognized, certified, or accredited by the following organizations:

FCC-Registration No.: 184111

Shenzhen Anbotek Compliance Laboratory Limited, EMC Laboratory has been registered and fully described in a report filed with the (FCC) Federal Communications Commission. The acceptance letter from the FCC is maintained in our files. Registration No. 184111.

ISED-Registration No.: 8058A

Shenzhen Anbotek Compliance Laboratory Limited, EMC Laboratory has been registered and fully described in a report filed with the (ISED) Innovation, Science and Economic Development Canada. The acceptance letter from the ISED is maintained in our files. Registration 8058A.

Test Location

Shenzhen Anbotek Compliance Laboratory Limited.

1/F, Building D, Sogood Science and Technology Park, Sanwei community, Hangcheng Street, Bao'an District, Shenzhen, Guangdong, China.518102



2. Summary of Test

2.1. Summary of test result

Description of Test	FCC Rules	Requirements	Result
Conducted Output Power	Part 2.1046 Part 22.913(a) Part 24.232(b) Part 27.50(b) Part 27.50(c) Part 27.50(d) Part 90.635	N/A	Compliance
Peak-Average Ratio	Part 22.913 Part 24.232 Part 27.50	≤13dB	Compliance
Modulation Characteristics	§ 2.1047	Digital modulation	N/A
99% Occupied Bandwidth & 26 dB Bandwidth	Part 2.1049	OBW: No limit EBW: No limit	Compliance
Conducted Spurious Emission	Part 2.1051 Part 22.917 Part 24.238 Part 27.53(c)(f) Part 27.53(g) Part 27.53(h) Part 90.691	≤ -13dBm(LTE Band5,26(824-849MHz)) ≤ -13dBm(LTE Band2,25) Refer to clause 7.1 for LTE Band13 ≤ -13dBm(LTE Band12) ≤ -13dBm(LTE Band4) ≤ -13dBm(LTE Band26(814-824MHz))	Compliance
Band Edge	Part 2.1051 Part 22.917 Part 24.238 Part 27.53(c)(f) Part 27.53(g) Part 27.53(h) Part 90.691	≤ -13dBm (LTE Band5, 26(824-849MHz)) ≤ -13dBm (LTE Band2,25) Refer to clause 8.1 for LTE Band13 ≤ -13dBm (LTE Band12) ≤ -13dBm (LTE Band4) Refer to clause 8.1 for LTE Band26 (814-824MHz))	Compliance
Frequency stability VS. temperature	Part 2.1055(a)(1)(b) Part 22.355 Part 24.235 Part 27.54 Part 90.213	≤ ±2.5ppm	Compliance
Frequency stability VS. voltage	Part 2.1055(d)(1)(2) Part 22.355 Part 24.235 Part 27.54	≤ ±2.5ppm	Compliance



	Part 90.213		
ERP and EIRP	Part 2.1046 Part 22.913(a) Part 24.232(c) Part 27.50(b) Part 27.50(c) Part 27.50(d) Part 90.635	ERP ≤ 7W(LTE Band 5,26(824-849MHz)) EIRP ≤ 2W(LTE Band 2,25) ERP ≤ 3W(LTE Band 13) ERP ≤ 3W(LTE Band 12) EIRP ≤ 1W(LTE Band 4) ERP ≤ 100W(LTE Band 26(814-824MHz))	Compliance
Radiated Spurious Emission	Part 2.1053 Part 22.917 Part 24.238 Part 27.53(c)(f) Part 27.53(g) Part 27.53(h) Part 90.691	≤ -13dBm(LTE Band5,26(824-849MHz)) ≤ -13dBm(LTE Band2,25) Refer to clause 9.1 for LTE Band13 ≤ -13dBm(LTE Band12) ≤ -13dBm(LTE Band4) ≤ -13dBm(LTE Band26(814-824MHz))	Compliance

Note:

1. "N/A" is an abbreviation for Not Applicable.
2. Testing was performed by configuring EUT to maximum output power status, the declared output power class for different



3. Conducted Output Power Test

3.1. Test Standard and Limit

Applicable Standard:	Part 2.1046 Part 22.913(a) Part 24.232(c) Part 27.50(b) Part 27.50(c) Part 27.50(d) Part 90.635
Limit:	N/A

3.2. Test Setup

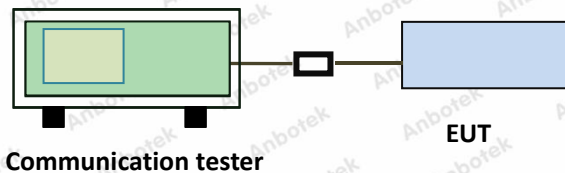

3.3. Test Procedure

1. The EUT output port was connected to communication tester.
2. Set EUT at maximum power through communication tester.
3. Select lowest, middle, and highest channels for each band and different modulation.
4. Measure the maximum burst average power.

3.4. Test Data

Pass

Please refer to Appendix A of the Appendix Test Data.



4. Peak-Average Ratio

4.1. Test Standard and Limit

Applicable Standard:	Part 22.913 Part 24.232 Part 27.50
Limit:	≤13dB

4.2. Test Setup

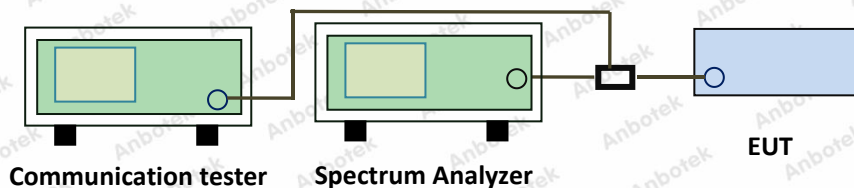

4.3. Test Procedure

According with KDB 971168 D01 Section 5.7:

1. The EUT was connected to the spectrum analyzer and communication tester via a power splitter.
2. Set EUT in maximum power output.
3. Center Frequency = Carrier frequency, RBW > Emission bandwidth of signal.
4. The signal analyzer was set to collect one million samples to generate the CCDF curve.
5. The measurement interval was set depending on the type of signal analyzed.
 - i. For continuous signals (>98% duty cycle), the measurement interval was set to 1ms.
 - ii. For burst transmissions, the spectrum analyzer is set to use an internal "RF Burst" trigger that is synced with an incoming pulse and the measurement interval is set to less than the duration of the "on time" of one burst to ensure that energy is only captured during a time in which the transmitter is operating at maximum power
6. Record the maximum PAPR level associated with a probability of 0.1%.

4.4. Test Data

Pass

Please refer to Appendix B of the Appendix Test Data.



5. Modulation Characteristic

According to FCC § 2.1047, Part 22H, Part 24E, Part 27C, Part 90S there is no specific requirement for digital modulation, therefore modulation characteristic is not presented.



6. 99% Occupied Bandwidth & 26 dB Bandwidth

6.1. Test Standard and Limit

Applicable Standard:	Part 2.1049
Limit:	N/A

6.2. Test Setup

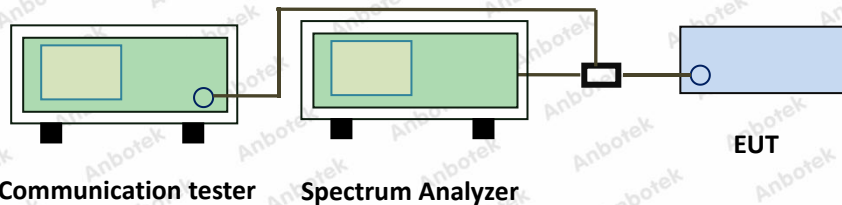

6.3. Test Procedure

1. The EUT was connected to the spectrum analyzer and communication tester via a power splitter.
2. Set EUT in maximum power output.
3. Spectrum analyzer setting as follow:
Center Frequency= Carrier frequency, RBW=1% to 5% of anticipated OBW, VBW= 3 * RBW,
Detector=Peak,
Trace maximum hold.
4. Record the value of 99% Occupied bandwidth and -26dB bandwidth.

6.4. Test Data

Pass

Please refer to Appendix C of the Appendix Test Data.



7. Conducted Spurious Emission

7.1. Test Standard and Limit

Applicable Standard:	Part 2.1051 Part 22.917 Part 24.238 Part 27.53(c)(f) Part 27.53(g) Part 27.53(h) Part 90.691
Limit:	$\leq -13\text{dBm}$ (LTE Band 5,26(824-849MHz)) $\leq -13\text{dBm}$ (LTE Band 2,25) $\leq -13\text{dBm}$ (LTE Band 12) $\leq -13\text{dBm}$ (LTE Band 4) $\leq -13\text{dBm}$ (LTE Band 26(814-824MHz)) For LTE Band 13: (1) On any frequency outside the 776-788 MHz band, the power of any emission shall be attenuated outside the band below the transmitter power (P) by at least $43 + 10 \log (P)$ dB; (2) For operations in the 775-788 MHz, emissions in the band 1559-1610 MHz shall be limited to -70 dBW/MHz. The limit of emissions is equal to -40 dBm.

7.2. Test Setup

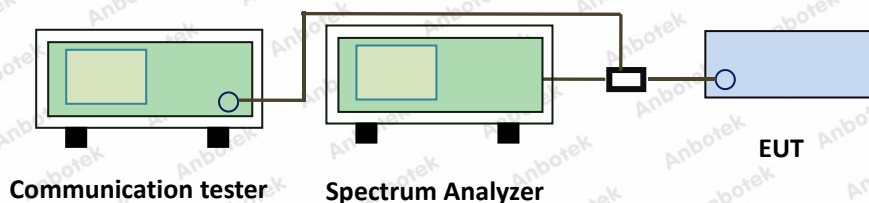

7.3. Test Procedure

1. The EUT was connected to the spectrum analyzer and communication tester via a power splitter.
2. Set EUT in maximum power output.
3. Spectrum analyzer setting as follow:
 Below 1GHz, RBW=100KHz, VBW = 300KHz, Detector=Peak, Sweep time= Auto
 Above 1GHz, RBW=1MHz, VBW=3MHz, Detector=Peak, Sweep time= Auto
 Scan frequency range up to 10th harmonic.
4. Record the test plot.



7.4. Test Data

Pass

Please refer to Appendix E of the Appendix Test Data.



8. Band Edge

8.1. Test Standard and Limit

Applicable Standard:	<p>Part 2.1051</p> <p>Part 22.917</p> <p>Part 24.238</p> <p>Part 27.53(c)(f)</p> <p>Part 27.53(g)</p> <p>Part 27.53(h)</p> <p>Part 90.691</p>
Limit:	<p>$\leq -13\text{dBm}$ (LTE Band 5,26(824-849MHz))</p> <p>$\leq -13\text{dBm}$ (LTE Band 2,25)</p> <p>$\leq -13\text{dBm}$ (LTE Band 12)</p> <p>$\leq -13\text{dBm}$ (LTE Band 4)</p> <p>For LTE Band 13:</p> <p>(1) On any frequency outside the 776-788 MHz band, the power of any emission shall be attenuated outside the band below the transmitter power (P) by at least $43 + 10 \log (P)$ dB;</p> <p>(2) On all frequencies between 763-775 MHz and 793-805 MHz, by a factor not less than $65 + 10 \log (P)$ dB in a 6.25 kHz band segment, for mobile and portable stations.</p> <p>For LTE Band 26(814-824MHz):</p> <p>(1) For any frequency removed from the EA licensee's frequency block by up to and including 37.5 kHz, the power of any emission shall be attenuated below the transmitter power (P) in watts by at least $116 \text{Log}_{10}(f/6.1)$ decibels or $50 + 10 \text{Log}_{10}(P)$ decibels or 80 decibels, whichever is the lesser attenuation, where f is the frequency removed from the center of the outer channel in the block in kilohertz and where f is greater than 12.5 kHz.</p> <p>(2) For any frequency removed from the EA licensee's frequency block greater than 37.5 kHz, the power of any emission shall be attenuated below the transmitter power (P) in watts by at least $43 + 10\text{Log}_{10}(P)$ decibels or 80 decibels, whichever is the lesser attenuation, where f is the frequency removed from the center of the outer channel in the block in kilohertz and where f is greater than 37.5 kHz.</p>



8.2. Test Setup

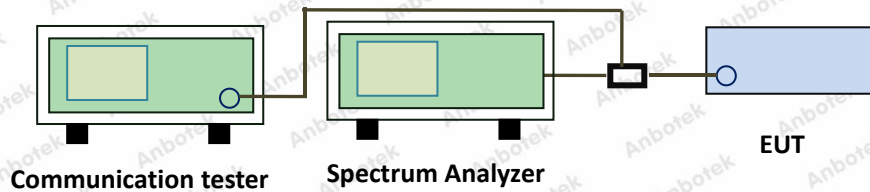

8.3. Test Procedure

1. The EUT was connected to the spectrum analyzer and communication tester via a power splitter.
2. Set EUT in maximum power output.
3. The band edges of low and high channels were measured.
4. Spectrum analyzer setting as follow:
RBW=3KHz, VBW = 10KHz, Sweep time= Auto
5. Record the test plot.

8.4. Test Data

Pass

Please refer to Appendix D of the Appendix Test Data.



9. Radiated Spurious Emission

9.1. Test Standard and Limit

Applicable Standard:	Part 2.1053 Part 22.917 Part 24.238 Part 27.53(c)(f) Part 27.53(g) Part 27.53(h) Part 90.691
Limit:	$\leq -13\text{dBm}(\text{LTE Band 5,26}(824\text{-}849\text{MHz}))$ $\leq -13\text{dBm}(\text{LTE Band 2,25})$ $\leq -13\text{dBm}(\text{LTE Band 12})$ $\leq -13\text{dBm}(\text{LTE Band 4})$ $\leq -13\text{dBm}(\text{LTE Band 26}(814\text{-}824\text{MHz}))$ For LTE Band 13: (1) On any frequency outside the 776-788 MHz band, the power of any emission shall be attenuated outside the band below the transmitter power (P) by at least $43 + 10 \log (P)$ dB; (2) For operations in the 775-788 MHz, emissions in the band 1559-1610 MHz shall be limited to -70 dBW/MHz. The limit of emissions is equal to -40 dBm.

9.2. Test Setup

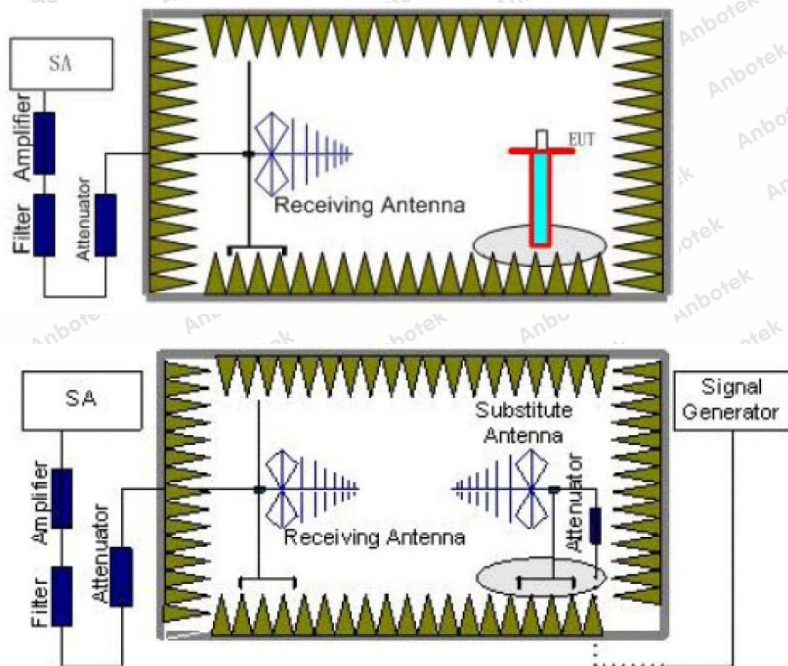

9.3. Test Procedure

1. Place the EUT in the center of the turntable.
 - a) For radiated emissions measurements performed at frequencies less than or equal to 1 GHz, the EUT shall be placed on a RF-transparent table at a nominal height of 80 cm above the reference ground plane
 - b) For radiated measurements performed at frequencies above 1 GHz, the EUT shall be placed on an RF transparent table at a nominal height of 1.5 m above the ground plane.
2. Unless the EUT uses an integral antenna, the EUT shall be terminated with a non-radiating transmitter load. In cases where the EUT uses an adjustable antenna, the antenna shall be adjusted through typical positions and lengths to maximize emissions levels.
3. The EUT shall be tested while operating on the frequency per manufacturer specification. Set the transmitter to operate in continuous transmit mode.
4. Receiver or Spectrum set as follow:
Below 1GHz, RBW=100kHz, VBW=300kHz, Detector=Peak, Sweep time=Auto
Above 1GHz, RBW=1MHz, VBW=3MHz, Detector=Peck, Sweep time=Auto
5. Each emission under consideration shall be evaluated:
 - a) Raise and lower the measurement antenna from 1 m to 4 m, as necessary to enable detection of the maximum emission amplitude relative to measurement antenna height.
 - b) Rotate the EUT through 360° to determine the maximum emission level relative to the axial position.
 - c) Return the turntable to the azimuth where the highest emission amplitude level was observed.
 - d) Vary the measurement antenna height again through 1 m to 4 m again to find the height associated with the maximum emission amplitude.
 - e) Record the measured emission amplitude level and frequency
6. Repeat step 5 for each emission frequency with the measurement antenna oriented in both the horizontal and vertical polarizations to determine the orientation that gives the maximum emissions amplitude.
7. Set-up the substitution measurement with the reference point of the substitution antenna located as near as possible to where the center of the EUT radiating element was located during the initial EUT measurement.
8. Maintain the previous measurement instrument settings and test set-up, with the exception that the EUT is removed and replaced by the substitution antenna.
9. Connect a signal generator to the substitution antenna; locate the signal generator so as to minimize any potential influences on the measurement results. Set the signal generator to the frequency where emissions are detected, and set an output power level such that the radiated signal can be detected by the measurement instrument, with sufficient dynamic range relative to the noise floor.
10. For each emission that was detected and measured in the initial test
 - a) Vary the measurement antenna height between 1 m to 4 m to maximize the received (measured) signal amplitude.
 - b) Adjust the signal generator output power level until the amplitude detected by the measurement instrument equals the amplitude level of the emission previously measured directly in step 5 and step 6.
 - c) Record the output power level of the signal generator when equivalence is achieved in step b).
11. Repeat step 8 through step 10 with the measurement antenna oriented in the opposite polarization.



12. Calculate the emission power in dBm referenced to a half-wave dipole using the following equation:

$$P_e = P_s(\text{dBm}) - \text{cable loss (dB)} + \text{antenna gain (dBd)}$$

where

P_e = equivalent emission power in dBm

P_s = source (signal generator) power in dBm

NOTE—dBd refers to the measured antenna gain in decibels relative to a half-wave dipole.

13. Correct the antenna gain of the substitution antenna if necessary to reference the emission power to a half-wave dipole. When using measurement antennas with the gain specified in dBi, the equivalent dipole-referenced gain can be determined from:

$$\text{gain (dBd)} = \text{gain (dBi)} - 2.15 \text{ dB.}$$

If necessary, the antenna gain can be calculated from calibrated antenna factor information

14. Provide the complete measurement results as a part of the test report.

9.4. Test Data

Pass

Please to see the following pages

LTE Band 2								
Bandwidth	Channel	Frequency (MHz)	Spurious Emission				Limit (dBm)	Result
			Polarization	Reading (dBm)	Factor (dB)	Level (dBm)		
1.4MHz	Low	3701.40	Vertical	-49.55	13.21	-36.34	-13.00	PASS
		5552.10	V	-56.76	16.61	-40.15		
		7402.80	V	-59.00	18.03	-40.97		
		3701.40	Horizontal	-50.12	13.21	-36.91		
		5552.10	H	-57.29	16.61	-40.68		
		7402.80	H	-59.45	18.03	-41.42		
	Mid	3760.00	Vertical	-48.27	12.36	-35.91	-13.00	PASS
		5640.00	V	-56.78	17.03	-39.75		
		7520.00	V	-58.44	17.85	-40.59		
		3760.00	Horizontal	-48.75	12.36	-36.39		
		5640.00	H	-57.29	17.03	-40.26		
		7520.00	H	-58.87	17.85	-41.02		
High	3818.60	Vertical	-47.96	12.78	-35.18	-13.00	PASS	
	5727.90	V	-56.95	17.86	-39.09			
	7637.20	V	-58.52	18.56	-39.96			
	3818.60	Horizontal	-48.92	12.78	-36.14			



3MHz		5727.90	H	-57.88	17.86	-40.02			
		7637.20	H	-59.38	18.56	-40.82			
	Low		3703.00	Vertical	-47.49	12.78	-34.71	-13.00	PASS
			5554.50	V	-54.45	16.69	-37.76		
			7406.00	V	-57.17	18.18	-38.99		
			3703.00	Horizontal	-47.77	12.78	-34.99	-13.00	PASS
			5554.50	H	-55.34	16.69	-38.65		
			7406.00	H	-58.29	18.18	-40.11		
	Mid		3760.00	Vertical	-46.20	12.79	-33.41	-13.00	PASS
			5640.00	V	-53.25	16.72	-36.53		
			7520.00	V	-55.87	18.22	-37.65		
			3760.00	Horizontal	-46.69	12.79	-33.90	-13.00	PASS
			5640.00	H	-54.61	16.72	-37.89		
			7520.00	H	-57.46	18.22	-39.24		
	High		3817.00	Vertical	-45.15	12.93	-32.22	-13.00	PASS
			5725.50	V	-52.68	17.01	-35.67		
			7634.00	V	-55.50	18.41	-37.09		
			3817.00	Horizontal	-45.69	12.93	-32.76	-13.00	PASS
5725.50			H	-54.03	17.01	-37.02			
7634.00			H	-56.12	18.41	-37.71			
5MHz	Low	3705.00	Vertical	-44.19	13.25	-30.94	-13.00	PASS	
		5557.50	V	-50.32	16.59	-33.73			
		7410.00	V	-53.75	18.12	-35.63			
		3705.00	Horizontal	-46.98	13.25	-33.73			
		5557.50	H	-55.34	16.59	-38.75			
		7410.00	H	-56.68	18.12	-38.56			
	Mid	3760.00	Vertical	-43.88	12.31	-31.57	-13.00	PASS	
		5640.00	V	-52.03	17.14	-34.89			
		7520.00	V	-54.59	17.96	-36.63			
		3760.00	Horizontal	-47.49	12.31	-35.18			
		5640.00	H	-56.87	17.14	-39.73			
		7520.00	H	-57.27	17.96	-39.31			
	High	3815.00	Vertical	-45.92	12.77	-33.15	-13.00	PASS	
		5722.50	V	-53.83	17.82	-36.01			
		7630.00	V	-56.19	18.59	-37.60			



10MHz		3815.00	Horizontal	-49.08	12.77	-36.31	-13.00	PASS		
		5722.50	H	-58.60	17.82	-40.78				
		7630.00	H	-58.70	18.59	-40.11				
	Low		3710.00	Vertical	-44.69	12.59	-32.10	-13.00	PASS	
			5565.00	V	-52.05	16.61	-35.44			
			7420.00	V	-55.27	18.35	-36.92			
		Mid		3710.00	Horizontal	-50.50	12.59	-37.91	-13.00	PASS
				5565.00	H	-58.49	16.61	-41.88		
				7420.00	H	-59.72	18.35	-41.37		
			Vertical	3760.00	Vertical	-46.05	12.71	-33.34		
				5640.00	V	-53.13	16.65	-36.48		
				7520.00	V	-56.44	18.27	-38.17		
		High		3760.00	Horizontal	-51.44	12.71	-38.73	-13.00	PASS
				5640.00	H	-59.75	16.65	-43.10		
				7520.00	H	-60.61	18.27	-42.34		
	Vertical		3810.00	Vertical	-46.71	12.91	-33.80			
			5715.00	V	-54.75	17.23	-37.52			
			7620.00	V	-57.97	18.59	-39.38			
15MHz	Low		3810.00	Horizontal	-50.65	12.91	-37.74	-13.00	PASS	
			5715.00	H	-59.75	17.23	-42.52			
			7620.00	H	-60.16	18.59	-41.57			
		Vertical	3715.00	Vertical	-46.17	13.21	-32.96			
			5572.50	V	-53.41	16.65	-36.76			
			7430.00	V	-56.85	18.29	-38.56			
	Mid		3715.00	Horizontal	-51.75	13.21	-38.54	-13.00	PASS	
			5572.50	H	-59.92	16.65	-43.27			
			7430.00	H	-60.50	18.29	-42.21			
		Vertical	3760.00	Vertical	-45.95	12.39	-33.56			
			5640.00	V	-54.51	17.18	-37.33			
			7520.00	V	-57.08	17.99	-39.09			
High		3760.00	Horizontal	-50.17	12.39	-37.78	-13.00	PASS		
		5640.00	H	-59.66	17.18	-42.48				
		7520.00	H	-59.75	17.99	-41.76				
	Vertical	3805.00	Vertical	-45.79	12.86	-32.93	-13.00	PASS		
		5707.50	V	-54.05	17.89	-36.16				



20MHz		7610.00	V	-56.62	18.69	-37.93		PASS
		3805.00	Horizontal	-51.63	12.86	-38.77		
		5707.50	H	-61.98	17.89	-44.09		
		7610.00	H	-62.11	18.69	-43.42		
	Low	3720.00	Vertical	-46.49	12.57	-33.92	-13.00	PASS
		5580.00	V	-53.87	16.59	-37.28		
		7440.00	V	-57.45	18.67	-38.78		
		3720.00	Horizontal	-51.78	12.57	-39.21		
		5580.00	H	-61.10	16.59	-44.51		
		7440.00	H	-62.44	18.67	-43.77		
	Mid	3760.00	Vertical	-47.01	12.76	-34.25	-13.00	PASS
		5640.00	V	-54.28	16.69	-37.59		
		7520.00	V	-57.45	18.38	-39.07		
		3760.00	Horizontal	-52.26	12.76	-39.50		
		5640.00	H	-61.44	16.69	-44.75		
		7520.00	H	-62.37	18.38	-43.99		
	High	3800.00	Vertical	-46.50	12.97	-33.53	-13.00	PASS
		5700.00	V	-53.82	17.19	-36.63		
7600.00		V	-56.65	18.28	-38.37			
3800.00		Horizontal	-52.78	12.97	-39.81			
5700.00		H	-62.23	17.19	-45.04			
7600.00		H	-62.52	18.28	-44.24			

LTE Band 4								
Bandwidth	Channel	Frequency (MHz)	Spurious Emission				Limit (dBm)	Result
			Polarization	Reading (dBm)	Factor (dB)	Level (dBm)		
1.4MHz	Low	3421.40	Vertical	-46.91	12.89	-34.02	-13.00	PASS
		5132.10	V	-55.05	15.86	-39.19		
		6842.80	V	-58.29	18.92	-39.37		
	Mid	3421.40	Horizontal	-47.86	12.89	-34.97	-13.00	PASS
		5132.10	H	-55.95	15.86	-40.09		
		6842.80	H	-59.05	18.92	-40.13		
Mid	3465.00	Vertical	-45.79	12.49	-33.30	-13.00	PASS	
	5197.50	V	-54.23	15.71	-38.52			
	6930.00	V	-57.00	18.26	-38.74			



3MHz	High	3465.00	Horizontal	-46.58	12.49	-34.09	-13.00	PASS		
		5197.50	H	-55.09	15.71	-39.38				
		6930.00	H	-57.72	18.26	-39.46				
	High	3508.60	Vertical	-45.09	13.01	-32.08	-13.00	PASS		
		5262.90	V	-53.30	15.89	-37.41				
		7017.20	V	-56.35	18.67	-37.68				
		3508.60	Horizontal	-46.10	13.01	-33.09				
		5262.90	H	-54.32	15.89	-38.43				
		7017.20	H	-57.22	18.67	-38.55				
		Low	3423.00	Vertical	-46.35	12.74			-33.61	-13.00
	5134.50		V	-54.46	15.68	-38.78				
	6846.00		V	-57.62	18.59	-39.03				
	3423.00		Horizontal	-47.05	12.74	-34.31				
	5134.50		H	-56.04	15.68	-40.36				
6846.00	H		-58.61	18.59	-40.02					
Mid	3465.00	Vertical	-47.70	12.49	-35.21	-13.00	PASS			
	5197.50	V	-56.27	15.89	-40.38					
	6930.00	V	-58.93	18.66	-40.27					
	3465.00	Horizontal	-49.87	12.49	-37.38					
	5197.50	H	-58.42	15.89	-42.53					
	6930.00	H	-61.20	18.66	-42.54					
	High	3507.00	Vertical	-49.73	13.44			-36.29	-13.00	PASS
		5260.50	V	-57.25	15.89			-41.36		
		7014.00	V	-59.59	18.39			-41.20		
		3507.00	Horizontal	-52.31	13.44			-38.87		
5260.50		H	-60.10	15.89	-44.21					
7014.00		H	-62.15	18.39	-43.76					
5MHz	Low	3425.00	Vertical	-47.19	12.87	-34.32	-13.00	PASS		
		5137.50	V	-55.77	15.85	-39.92				
		6850.00	V	-58.17	18.93	-39.24				
	Low	3425.00	Horizontal	-50.95	12.87	-38.08	-13.00	PASS		
		5137.50	H	-60.80	15.85	-44.95				
		6850.00	H	-62.06	18.93	-43.13				
	Mid	3465.00	Vertical	-47.38	12.47	-34.91	-13.00	PASS		
		5197.50	V	-55.07	15.7	-39.37				
		6930.00	V	-58.05	18.29	-39.76				



		3465.00	Horizontal	-51.24	12.47	-38.77	-13.00	PASS	
		5197.50	H	-60.09	15.7	-44.39			
		6930.00	H	-61.21	18.29	-42.92			
	High		3505.00	Vertical	-47.35	13.29	-34.06	-13.00	PASS
			5257.50	V	-56.00	15.86	-40.14		
		7010.00	V	-57.65	18.63	-39.02			
		3505.00	Horizontal	-51.51	13.29	-38.22			
			5257.50	H	-59.73	15.86	-43.87	-13.00	PASS
			7010.00	H	-61.11	18.63	-42.48		
	10MHz	Low	3430.00	Vertical	-45.28	12.72	-32.56	-13.00	PASS
5145.00			V	-56.67	15.61	-41.06			
6860.00			V	-57.08	18.62	-38.46			
3430.00			Horizontal	-51.20	12.72	-38.48			
5145.00			H	-59.72	15.61	-44.11			
6860.00			H	-61.31	18.62	-42.69			
Mid			3465.00	Vertical	-45.16	12.41	-32.75	-13.00	PASS
			5197.50	V	-57.16	15.92	-41.24		
			6930.00	V	-57.62	18.63	-38.99		
		3465.00	Horizontal	-51.10	12.41	-38.69			
		5197.50	H	-60.20	15.92	-44.28			
		6930.00	H	-61.48	18.63	-42.85			
High			3500.00	Vertical	-46.42	13.41	-33.01	-13.00	PASS
			5250.00	V	-57.07	15.59	-41.48		
			7000.00	V	-57.53	18.31	-39.22		
		3500.00	Horizontal	-52.30	13.41	-38.89			
		5250.00	H	-60.06	15.59	-44.47			
		7000.00	H	-61.32	18.31	-43.01			
15MHz		Low	3435.00	Vertical	-46.59	12.89	-33.70	-13.00	PASS
			5152.50	V	-56.64	15.86	-40.78		
	6870.00		V	-58.72	18.95	-39.77			
	3435.00		Horizontal	-50.58	12.89	-37.69			
	5152.50		H	-61.46	15.86	-45.60			
	6870.00		H	-59.88	18.95	-40.93			
	Mid		3465.00	Vertical	-48.15	12.49	-35.66	-13.00	PASS
			5197.50	V	-54.67	15.73	-38.94		
			6930.00	V	-59.81	18.31	-41.50		



20MHz	High	3465.00	Horizontal	-48.66	12.49	-36.17	-13.00	PASS	
		5197.50	H	-62.56	15.73	-46.83			
		6930.00	H	-58.07	18.31	-39.76			
	High	3495.00	Vertical	-50.42	13.32	-37.10	-13.00	PASS	
		5242.50	V	-53.51	15.88	-37.63			
		6990.00	V	-58.90	18.65	-40.25			
	High	3495.00	Horizontal	-48.12	13.32	-34.80	-13.00	PASS	
		5242.50	H	-60.06	15.88	-44.18			
		6990.00	H	-57.75	18.65	-39.10			
	20MHz	Low	3440.00	Vertical	-47.73	12.74	-34.99	-13.00	PASS
			5160.00	V	-52.80	15.65	-37.15		
			6880.00	V	-58.48	18.64	-39.84		
		Low	3440.00	Horizontal	-48.91	12.74	-36.17	-13.00	PASS
			5160.00	H	-60.91	15.65	-45.26		
			6880.00	H	-58.06	18.64	-39.42		
		Mid	3465.00	Vertical	-47.77	12.44	-35.33	-13.00	PASS
			5197.50	V	-53.24	15.93	-37.31		
			6930.00	V	-58.63	18.64	-39.99		
Mid		3465.00	Horizontal	-48.83	12.44	-36.39	-13.00	PASS	
		5197.50	H	-61.41	15.93	-45.48			
		6930.00	H	-60.27	18.64	-41.63			
High		3490.00	Vertical	-50.19	13.43	-36.76	-13.00	PASS	
		5235.00	V	-54.08	15.61	-38.47			
		6980.00	V	-59.39	18.34	-41.05			
High		3490.00	Horizontal	-50.82	13.43	-37.39	-13.00	PASS	
		5235.00	H	-61.34	15.61	-45.73			
		6980.00	H	-60.88	18.34	-42.54			

LTE Band 5								
Bandwidth	Channel	Frequency (MHz)	Spurious Emission			Limit (dBm)	Result	
			Polarization	Reading (dBm)	Factor (dB)			Level (dBm)
1.4MHz	Low	1649.40	Vertical	-43.47	7.29	-36.18	-13.00	PASS
		2474.10	V	-52.95	9.41	-43.54		
		3298.80	V	-57.07	12.69	-44.38		
		1649.40	Horizontal	-44.33	7.29	-37.04	-13.00	PASS
		2474.10	H	-53.97	9.41	-44.56		



	Mid	3298.80	H	-58.00	12.69	-45.31	-13.00	PASS
		1673.00	Vertical	-43.24	7.32	-35.92		
		2509.50	V	-52.69	9.39	-43.30		
		3346.00	V	-56.88	12.78	-44.10		
		1673.00	Horizontal	-44.10	7.32	-36.78		
		2509.50	H	-53.70	9.39	-44.31		
	3346.00	H	-57.86	12.78	-45.08	-13.00	PASS	
	High	1696.60	Vertical	-42.96	7.33			-35.63
		2544.90	V	-52.52	9.46			-43.06
		3393.20	V	-56.58	12.71			-43.87
		1696.60	Horizontal	-43.09	7.33			-35.76
		2544.90	H	-52.40	9.46			-42.94
3393.20		H	-56.80	12.71	-44.09			
3MHz	Low	1651.00	Vertical	-42.46	7.36	-35.10	-13.00	PASS
		2476.50	V	-52.07	9.51	-42.56		
		3302.00	V	-56.16	12.72	-43.44		
		1651.00	Horizontal	-42.77	7.36	-35.41		
		2476.50	H	-52.12	9.51	-42.61		
		3302.00	H	-56.53	12.72	-43.81		
	Mid	1673.00	Vertical	-42.25	7.41	-34.84	-13.00	PASS
		2509.50	V	-51.83	9.52	-42.31		
		3346.00	V	-55.94	12.73	-43.21		
		1673.00	Horizontal	-42.35	7.41	-34.94		
		2509.50	H	-51.75	9.52	-42.23		
		3346.00	H	-56.18	12.73	-43.45		
	High	1695.00	Vertical	-41.78	7.52	-34.26	-13.00	PASS
		2542.50	V	-51.24	9.46	-41.78		
		3390.00	V	-55.52	12.81	-42.71		
		1695.00	Horizontal	-42.03	7.52	-34.51		
		2542.50	H	-51.29	9.46	-41.83		
		3390.00	H	-55.92	12.81	-43.11		
5MHz	Low	1653.00	Vertical	-40.80	7.61	-33.19	-13.00	PASS
		2479.50	V	-50.61	9.49	-41.12		
		3306.00	V	-54.69	12.86	-41.83		
		1653.00	Horizontal	-42.38	7.61	-34.77		
		2479.50	H	-51.56	9.49	-42.07		



	Mid	3306.00	H	-56.18	12.86	-43.32	-13.00	PASS	
		1673.00	Vertical	-41.10	7.72	-33.38			
		2509.50	V	-50.83	9.53	-41.30			
		3346.00	V	-54.84	12.84	-42.00			
		1673.00	Horizontal	-42.64	7.72	-34.92			
		2509.50	H	-51.72	9.53	-42.19			
	3346.00	H	-56.28	12.84	-43.44	-13.00	PASS		
	High	1693.00	Vertical	-41.41	7.79			-33.62	
		2539.50	V	-51.05	9.53			-41.52	
		3386.00	V	-55.10	12.89			-42.21	
		1693.00	Horizontal	-42.27	7.79			-34.48	
		2539.50	H	-51.30	9.53			-41.77	
		3386.00	H	-55.98	12.89	-43.09			
	10MHz	Low	1658.00	Vertical	-41.13	7.81	-33.32	-13.00	PASS
			2487.00	V	-50.82	9.56	-41.26		
			3316.00	V	-54.90	12.91	-41.99		
			1658.00	Horizontal	-42.63	7.81	-34.82		
			2487.00	H	-51.65	9.56	-42.09		
3316.00			H	-56.28	12.91	-43.37	-13.00		
Mid		1673.00	Vertical	-41.41	7.83	-33.58			
		2509.50	V	-51.09	9.59	-41.50			
		3346.00	V	-55.16	12.94	-42.22			
		1673.00	Horizontal	-42.84	7.83	-35.01			
		2509.50	H	-51.83	9.59	-42.24			
		3346.00	H	-56.46	12.94	-43.52	-13.00	PASS	
High		1688.00	Vertical	-41.70	7.89	-33.81			
		2532.00	V	-51.33	9.62	-41.71			
		3376.00	V	-55.38	12.96	-42.42			
		1688.00	Horizontal	-43.08	7.89	-35.19			
		2532.00	H	-52.03	9.62	-42.41			
		3376.00	H	-56.62	12.96	-43.66			



LTE Band 12								
Bandwidth	Channel	Frequency (MHz)	Spurious Emission				Limit (dBm)	Result
			Polarization	Reading (dBm)	Factor (dB)	Level (dBm)		
1.4MHz	Low	1399.40	Vertical	-40.27	4.21	-36.06	-13.00	PASS
		2099.10	V	-48.86	9.12	-39.74		
		2798.80	V	-52.03	11.36	-40.67		
		1399.40	Horizontal	-41.24	4.21	-37.03	-13.00	
		2099.10	H	-49.77	9.12	-40.65		
		2798.80	H	-52.80	11.36	-41.44		
	Mid	1415.00	Vertical	-39.59	4.26	-35.33	-13.00	PASS
		2122.50	V	-48.21	9.15	-39.06		
		2830.00	V	-51.42	11.39	-40.03		
		1415.00	Horizontal	-40.40	4.26	-36.14	-13.00	
		2122.50	H	-49.08	9.15	-39.93		
		2830.00	H	-52.15	11.39	-40.76		
	High	1430.60	Vertical	-38.38	4.29	-34.09	-13.00	PASS
		2145.90	V	-47.04	9.11	-37.93		
		2861.20	V	-50.27	11.31	-38.96		
		1430.60	Horizontal	-40.00	4.29	-35.71	-13.00	
		2145.90	H	-48.63	9.11	-39.52		
		2861.20	H	-51.72	11.31	-40.41		
3MHz	Low	1401.00	Vertical	-37.61	4.32	-33.29	-13.00	PASS
		2101.50	V	-44.82	9.16	-35.66		
		2802.00	V	-48.66	11.35	-37.31		
		1401.00	Horizontal	-38.07	4.32	-33.75	-13.00	
		2101.50	H	-46.35	9.16	-37.19		
		2802.00	H	-50.54	11.35	-39.19		
	Mid	1415.00	Vertical	-35.33	4.26	-31.07	-13.00	PASS
		2122.50	V	-42.72	9.15	-33.57		
		2830.00	V	-46.42	11.39	-35.03		
		1415.00	Horizontal	-36.16	4.26	-31.90	-13.00	
		2122.50	H	-45.05	9.15	-35.90		
		2830.00	H	-49.09	11.39	-37.70		
	High	1429.00	Vertical	-33.46	4.42	-29.04	-13.00	PASS



		2143.50	V	-41.35	9.25	-32.10		
		2858.00	V	-45.53	11.46	-34.07		
		1429.00	Horizontal	-34.38	4.42	-29.96		
		2143.50	H	-43.67	9.25	-34.42		
		2858.00	H	-46.55	11.46	-35.09		
5MHz	Low	1403.00	Vertical	-30.99	4.13	-26.86		
		2104.50	V	-37.85	9.06	-28.79		
		2806.00	V	-42.86	11.27	-31.59		
		1403.00	Horizontal	-35.75	4.13	-31.62		
		2104.50	H	-46.43	9.06	-37.37		
		2806.00	H	-47.81	11.27	-36.54		
	Mid	1415.00	Vertical	-32.18	4.26	-27.92		
		2122.50	V	-39.92	9.15	-30.77		
		2830.00	V	-44.69	11.39	-33.30		
		1415.00	Horizontal	-38.34	4.26	-34.08		
		2122.50	H	-48.19	9.15	-39.04		
		2830.00	H	-49.21	11.39	-37.82		
	High	1427.00	Vertical	-34.83	4.22	-30.61		
		2140.50	V	-41.84	9.16	-32.68		
		2854.00	V	-46.27	11.32	-34.95		
		1427.00	Horizontal	-40.23	4.22	-36.01		
		2140.50	H	-49.99	9.16	-40.83		
		2854.00	H	-50.50	11.32	-39.18		
10MHz	Low	1408.00	Vertical	-33.11	4.29	-28.82		
		2112.00	V	-40.91	9.19	-31.72		
		2816.00	V	-45.14	11.35	-33.79		
		1408.00	Horizontal	-43.03	4.29	-38.74		
		2112.00	H	-51.89	9.19	-42.70		
		2816.00	H	-52.68	11.35	-41.33		
	Mid	1415.00	Vertical	-35.20	4.26	-30.94		
		2122.50	V	-42.64	9.15	-33.49		
		2830.00	V	-47.31	11.39	-35.92		
		1415.00	Horizontal	-44.40	4.26	-40.14		
		2122.50	H	-53.93	9.15	-44.78		
		2830.00	H	-54.37	11.39	-42.98		



	High	1422.00	Vertical	-36.09	4.36	-31.73	-13.00	PASS
		2133.00	V	-44.53	9.27	-35.26		
		2844.00	V	-49.36	11.39	-37.97		
		1422.00	Horizontal	-42.81	4.36	-38.45	-13.00	PASS
		2133.00	H	-53.07	9.27	-43.80		
		2844.00	H	-53.06	11.39	-41.67		

LTE Band 13								
Bandwidth	Channel	Frequency (MHz)	Spurious Emission				Limit (dBm)	Result
			Polarization	Reading (dBm)	Factor (dB)	Level (dBm)		
5MHz	Low	1559.00	Vertical	-59.92	4.98	-54.94	-40.00	PASS
		2338.50	V	-49.66	9.12	-40.54	-13.00	
		3118.00	V	-53.52	12.46	-41.06		
		1559.00	Horizontal	-60.48	4.98	-55.50	-40.00	PASS
		2338.50	H	-50.19	9.12	-41.07	-13.00	
		3118.00	H	-53.97	12.46	-41.51		
	Mid	1564.00	Vertical	-59.55	5.03	-54.52	-40.00	PASS
		2346.00	V	-49.33	9.19	-40.14	-13.00	
		3128.00	V	-53.16	12.47	-40.69		
		1564.00	Horizontal	-60.01	5.03	-54.98	-40.00	PASS
		2346.00	H	-49.84	9.19	-40.65	-13.00	
		3128.00	H	-53.58	12.47	-41.11		
	High	1569.00	Vertical	-58.89	5.09	-53.80	-40.00	PASS
		2353.50	V	-48.70	9.22	-39.48	-13.00	
		3138.00	V	-52.60	12.53	-40.07		
		1569.00	Horizontal	-59.82	5.09	-54.73	-40.00	PASS
		2353.50	H	-49.63	9.22	-40.41	-13.00	
		3138.00	H	-53.44	12.53	-40.91		
10MHz	Mid	1564.00	Vertical	-58.36	5.03	-53.33	-40.00	PASS
		2346.00	V	-47.35	9.19	-38.16	-13.00	
		3128.00	V	-51.58	12.47	-39.11		
		1564.00	Horizontal	-58.62	5.03	-53.59	-40.00	PASS
		2346.00	H	-48.24	9.19	-39.05	-13.00	
		3128.00	H	-52.67	12.47	-40.20		



LTE Band 25								
Bandwidth	Channel	Frequency (MHz)	Spurious Emission				Limit (dBm)	Result
			Polarization	Reading (dBm)	Factor (dB)	Level (dBm)		
1.4MHz	Low	3701.40	Vertical	-49.80	13.44	-36.36	-13.00	PASS
		5552.10	V	-56.82	16.65	-40.17		
		7402.80	V	-58.77	17.79	-40.98		
		3701.40	Horizontal	-50.34	13.44	-36.90		
		5552.10	H	-57.33	16.65	-40.68		
		7402.80	H	-59.20	17.79	-41.41		
	Mid	3765.00	Vertical	-49.47	13.52	-35.95	-13.00	PASS
		5647.50	V	-56.46	16.67	-39.79		
		7530.00	V	-58.47	17.85	-40.62		
		3765.00	Horizontal	-49.92	13.52	-36.40		
		5647.50	H	-56.95	16.67	-40.28		
		7530.00	H	-58.88	17.85	-41.03		
	High	3828.60	Vertical	-48.86	13.61	-35.25	-13.00	PASS
		5742.90	V	-55.86	16.70	-39.16		
		7657.20	V	-57.90	17.88	-40.02		
		3828.60	Horizontal	-49.77	13.61	-36.16		
		5742.90	H	-56.75	16.70	-40.05		
		7657.20	H	-58.72	17.88	-40.84		
3MHz	Low	3703.00	Vertical	-48.29	13.49	-34.80	-13.00	PASS
		5554.50	V	-54.52	16.63	-37.89		
		7406.00	V	-56.89	17.80	-39.09		
		3703.00	Horizontal	-48.55	13.49	-35.06		
		5554.50	H	-55.37	16.63	-38.74		
		7406.00	H	-57.96	17.80	-40.16		
	Mid	3765.00	Vertical	-47.08	13.52	-33.56	-13.00	PASS
		5647.50	V	-53.39	16.67	-36.72		
		7530.00	V	-55.66	17.85	-37.81		
		3765.00	Horizontal	-47.54	13.52	-34.02		
		5647.50	H	-54.68	16.67	-38.01		
		7530.00	H	-57.18	17.85	-39.33		
High	3827.00	Vertical	-46.05	13.63	-32.42	-13.00	PASS	
	5740.50	V	-52.60	16.71	-35.89			



5MHz	Low	7654.00	V	-55.12	17.85	-37.27	-13.00	PASS		
		3827.00	Horizontal	-46.56	13.63	-32.93				
		5740.50	H	-53.89	16.71	-37.18				
			7654.00	H	-55.72	17.85	-37.87			
			3705.00	Vertical	-44.72	13.52	-31.20			
			5557.50	V	-50.69	16.66	-34.03	-13.00	PASS	
		7410.00	V	-53.70	17.82	-35.88				
		3705.00	Horizontal	-47.38	13.52	-33.86				
		5557.50	H	-55.50	16.66	-38.84	-13.00	PASS		
		7410.00	H	-56.50	17.82	-38.68				
	Mid	3765.00	Vertical	-45.32	13.52	-31.80	-13.00	PASS		
			5647.50	V	-51.81	16.67			-35.14	
			7530.00	V	-54.69	17.85			-36.84	
			3765.00	Horizontal	-48.76	13.52			-35.24	
			5647.50	H	-56.45	16.67			-39.78	
			7530.00	H	-57.25	17.85			-39.40	
	High	17330.00	Vertical	-46.97	13.66	-33.31	-13.00	PASS		
			5737.50	V	-53.01	16.80			-36.21	
			7650.00	V	-55.66	17.90			-37.76	
			3825.00	Horizontal	-49.98	13.66			-36.32	
			5737.50	H	-57.58	16.80			-40.78	
			7650.00	H	-58.06	17.90			-40.16	
10MHz	Low	3710.00	Vertical	-45.86	13.55	-32.31	-13.00	PASS		
				5565.00	V	-52.27			16.60	-35.67
				7420.00	V	-54.96			17.85	-37.11
				3710.00	Horizontal	-51.40			13.55	-37.85
				5565.00	H	-58.43			16.60	-41.83
				7420.00	H	-59.22			17.85	-41.37
		Mid	3765.00	Vertical	-47.02	13.52	-33.50	-13.00	PASS	
				5647.50	V	-53.34	16.67			-36.67
				7530.00	V	-56.16	17.85			-38.31
				3765.00	Horizontal	-52.15	13.52			-38.63
				5647.50	H	-59.67	16.67			-43.00
				7530.00	H	-60.14	17.85			-42.29
		High	3820.00	Vertical	-47.63	13.69	-33.94	-13.00	PASS	
				5730.00	V	-54.50	16.84			-37.66



		7640.00	V	-57.34	17.88	-39.46	-13.00	PASS
		3820.00	Horizontal	-51.37	13.69	-37.68		
		5730.00	H	-59.29	16.84	-42.45		
		7640.00	H	-59.44	17.88	-41.56		
		3715.00	Vertical	-46.74	13.61	-33.13		
		5572.50	V	-53.54	16.61	-36.93		
15MHz	Low	7430.00	V	-56.56	17.88	-38.68	-13.00	PASS
		3715.00	Horizontal	-52.05	13.61	-38.44		
		5572.50	H	-59.78	16.61	-43.17		
		7430.00	H	-60.05	17.88	-42.17		
		3765.00	Vertical	-47.22	13.52	-33.70		
		5647.50	V	-54.14	16.67	-37.47		
	Mid	7530.00	V	-57.04	17.85	-39.19	-13.00	PASS
		3765.00	Horizontal	-51.23	13.52	-37.71		
		5647.50	H	-59.09	16.67	-42.42		
		7530.00	H	-59.59	17.85	-41.74		
		3815.00	Vertical	-46.87	13.77	-33.10		
		5722.50	V	-53.22	16.87	-36.35		
High	7630.00	V	-55.92	17.84	-38.08	-13.00	PASS	
	3815.00	Horizontal	-52.43	13.77	-38.66			
	5722.50	H	-60.83	16.87	-43.96			
	7630.00	H	-61.16	17.84	-43.32			
	3720.00	Vertical	-47.71	13.67	-34.04			
	5580.00	V	-54.02	16.60	-37.42			
20MHz	Low	7440.00	V	-56.80	17.91	-38.89	-13.00	PASS
		3720.00	Horizontal	-52.77	13.67	-39.10		
		5580.00	H	-60.98	16.60	-44.38		
		7440.00	H	-61.58	17.91	-43.67		
		3765.00	Vertical	-47.89	13.52	-34.37		
		5647.50	V	-54.40	16.67	-37.73		
	Mid	7530.00	V	-57.03	17.85	-39.18	-13.00	PASS
		3765.00	Horizontal	-52.91	13.52	-39.39		
		5647.50	H	-61.29	16.67	-44.62		
		7530.00	H	-61.74	17.85	-43.89		
		3810.00	Vertical	-47.49	13.81	-33.68		
		5715.00	V	-53.66	16.85	-36.81		



	7620.00	V	-56.39	17.87	-38.52	-13.00	PASS
	3810.00	Horizontal	-53.51	13.81	-39.70		
	5715.00	H	-61.76	16.85	-44.91		
	7620.00	H	-62.01	17.87	-44.14		

LTE Band 26 (814-824MHz)								
Bandwidth	Channel	Frequency (MHz)	Spurious Emission			Limit (dBm)	Result	
			Polarization	Reading (dBm)	Factor (dB)			Level (dBm)
1.4MHz	Low	1629.40	Vertical	-40.19	4.15	-36.04	-13.00	PASS
		2444.10	V	-48.98	9.19	-39.79		
		3258.80	V	-53.51	12.79	-40.72		
		1629.40	Horizontal	-41.14	4.15	-36.99		
		2444.10	H	-49.88	9.19	-40.69		
		3258.80	H	-54.27	12.79	-41.48		
	Mid	1638.00	Vertical	-39.68	4.36	-35.32	-13.00	PASS
		2457.00	V	-48.36	9.24	-39.12		
		3276.00	V	-52.94	12.85	-40.09		
		1638.00	Horizontal	-40.48	4.36	-36.12		
		2457.00	H	-49.22	9.24	-39.98		
		3276.00	H	-53.66	12.85	-40.81		
	High	1646.60	Vertical	-38.32	4.22	-34.10	-13.00	PASS
		2469.90	V	-47.26	9.25	-38.01		
		3293.20	V	-51.86	12.83	-39.03		
		1646.60	Horizontal	-39.91	4.22	-35.69		
		2469.90	H	-48.83	9.25	-39.58		
		3293.20	H	-53.30	12.83	-40.47		
3MHz	Low	1631.00	Vertical	-37.49	4.18	-33.31	-13.00	PASS
		2446.50	V	-44.99	9.21	-35.78		
		3262.00	V	-50.22	12.82	-37.40		
		1631.00	Horizontal	-37.94	4.18	-33.76		
		2446.50	H	-46.50	9.21	-37.29		
		3262.00	H	-52.09	12.82	-39.27		
	Mid	1638.00	Vertical	-35.49	4.36	-31.13	-13.00	PASS
		2457.00	V	-42.96	9.24	-33.72		
		3276.00	V	-48.00	12.84	-35.16		



5MHz	High	1638.00	Horizontal	-36.30	4.36	-31.94	-13.00	PASS
		2457.00	H	-45.26	9.24	-36.02		
		3276.00	H	-50.65	12.84	-37.81		
	High	1645.00	Vertical	-33.34	4.21	-29.13	-13.00	PASS
		2467.50	V	-41.56	9.29	-32.27		
		3290.00	V	-47.04	12.83	-34.21		
		1645.00	Horizontal	-34.23	4.21	-30.02		
		2467.50	H	-43.85	9.29	-34.56		
		3290.00	H	-48.07	12.83	-35.24		
	Low	1633.00	Vertical	-31.20	4.22	-26.98	-13.00	PASS
		2449.50	V	-38.21	9.2	-29.01		
		3266.00	V	-44.58	12.81	-31.77		
		1633.00	Horizontal	-35.87	4.22	-31.65		
		2449.50	H	-46.67	9.2	-37.47		
3266.00		H	-49.48	12.81	-36.67			
Mid	1638.00	Vertical	-32.39	4.36	-28.03	-13.00	PASS	
	2457.00	V	-40.20	9.24	-30.96			
	3276.00	V	-46.29	12.84	-33.45			
	1638.00	Horizontal	-38.44	4.36	-34.08			
	2457.00	H	-48.36	9.24	-39.12			
	3276.00	H	-50.77	12.84	-37.93			
High	1643.00	Vertical	-34.84	4.16	-30.68	-13.00	PASS	
	2464.50	V	-42.12	9.28	-32.84			
	3286.00	V	-47.86	12.79	-35.07			
	1643.00	Horizontal	-40.14	4.16	-35.98			
	2464.50	H	-50.16	9.28	-40.88			
	3286.00	H	-52.06	12.79	-39.27			
10MHz	Mid	1638.00	Vertical	-33.17	4.25	-28.92	-13.00	PASS
		2457.00	V	-41.12	9.23	-31.89		
		3276.00	V	-46.70	12.77	-33.93		
		1638.00	Horizontal	-42.92	4.25	-38.67		
		2457.00	H	-51.95	9.23	-42.72		
		3276.00	H	-54.16	12.77	-41.39		



LTE Band 26 (824-849MHz)								
Bandwidth	Channel	Frequency (MHz)	Spurious Emission				Limit (dBm)	Result
			Polarization	Reading (dBm)	Factor (dB)	Level (dBm)		
1.4MHz	Low	1649.40	Vertical	-40.47	4.31	-36.16	-13.00	PASS
		2474.10	V	-49.28	9.35	-39.93		
		3298.80	V	-53.77	12.95	-40.82		
		1649.40	Horizontal	-41.27	4.31	-36.96		
		2474.10	H	-50.04	9.35	-40.69		
		3298.80	H	-54.41	12.95	-41.46		
	Mid	1673.00	Vertical	-40.08	4.52	-35.56	-13.00	PASS
		2509.50	V	-48.76	9.40	-39.36		
		3346.00	V	-53.30	13.01	-40.29		
		1673.00	Horizontal	-40.74	4.52	-36.22		
		2509.50	H	-49.49	9.40	-40.09		
		3346.00	H	-53.90	13.01	-40.89		
	High	1696.60	Vertical	-38.91	4.38	-34.53	-13.00	PASS
		2544.90	V	-47.83	9.41	-38.42		
		3393.20	V	-52.39	12.99	-39.40		
		1696.60	Horizontal	-40.24	4.38	-35.86		
		2544.90	H	-49.16	9.41	-39.75		
		3393.20	H	-53.59	12.99	-40.60		
3MHz	Low	1651.00	Vertical	-38.20	4.34	-33.86	-13.00	PASS
		2476.50	V	-45.91	9.37	-36.54		
		3302.00	V	-51.01	12.98	-38.03		
		1651.00	Horizontal	-38.57	4.34	-34.23		
		2476.50	H	-47.19	9.37	-37.82		
		3302.00	H	-52.57	12.98	-39.59		
	Mid	1673.00	Vertical	-36.54	4.52	-32.02	-13.00	PASS
		2509.50	V	-44.20	9.40	-34.80		
		3346.00	V	-49.13	13.00	-36.13		
		1673.00	Horizontal	-37.21	4.52	-32.69		
		2509.50	H	-46.14	9.40	-36.74		
		3346.00	H	-51.35	13.00	-38.35		
High	1695.00	Vertical	-34.70	4.37	-30.33	-13.00	PASS	
	2542.50	V	-43.03	9.45	-33.58			



		3390.00	V	-48.32	12.99	-35.33	-13.00	PASS
		1695.00	Horizontal	-35.44	4.37	-31.07		
		2542.50	H	-44.96	9.45	-35.51		
		3390.00	H	-49.17	12.99	-36.18		
		1653.00	Vertical	-32.90	4.38	-28.52		
		2479.50	V	-40.19	9.36	-30.83		
5MHz	Low	3306.00	V	-46.24	12.97	-33.27	-13.00	PASS
		1653.00	Horizontal	-36.83	4.38	-32.45		
		2479.50	H	-47.33	9.36	-37.97		
		3306.00	H	-50.36	12.97	-37.39		
		1673.00	Vertical	-33.93	4.52	-29.41		
		2509.50	V	-41.87	9.40	-32.47		
	Mid	3346.00	V	-47.69	13.00	-34.69	-13.00	PASS
		1673.00	Horizontal	-39.02	4.52	-34.50		
		2509.50	H	-48.76	9.40	-39.36		
		3346.00	H	-51.45	13.00	-38.45		
		1693.00	Vertical	-35.97	4.32	-31.65		
		2539.50	V	-43.50	9.44	-34.06		
	High	3386.00	V	-49.01	12.95	-36.06	-13.00	PASS
		1693.00	Horizontal	-40.42	4.32	-36.10		
		2539.50	H	-50.29	9.44	-40.85		
		3386.00	H	-52.53	12.95	-39.58		
		1658.00	Vertical	-34.57	4.41	-30.16		
		2487.00	V	-42.65	9.39	-33.26		
10MHz	Low	3316.00	V	-48.02	12.93	-35.09	-13.00	PASS
		1658.00	Horizontal	-42.78	4.41	-38.37		
		2487.00	H	-51.79	9.39	-42.40		
		3316.00	H	-54.30	12.93	-41.37		
		1673.00	Vertical	-36.44	4.52	-31.92		
		2509.50	V	-44.14	9.40	-34.74		
	Mid	3346.00	V	-49.87	13.00	-36.87	-13.00	PASS
		1673.00	Horizontal	-44.05	4.52	-39.53		
		2509.50	H	-53.53	9.40	-44.13		
		3346.00	H	-55.74	13.00	-42.74		
		1688.00	Vertical	-37.00	4.42	-32.58		
		2532.00	V	-45.66	9.45	-36.21		



		3376.00	V	-51.49	12.91	-38.58	-13.00	PASS
		1688.00	Horizontal	-42.55	4.42	-38.13		
		2532.00	H	-52.76	9.45	-43.31		
15MHz	Low	3376.00	H	-54.56	12.91	-41.65	-13.00	PASS
		1663.00	Vertical	-35.80	4.42	-31.38		
		2494.50	V	-44.48	9.35	-35.13		
		3326.00	V	-50.37	12.95	-37.42		
		1663.00	Horizontal	-43.68	4.42	-39.26		
		2494.50	H	-53.73	9.35	-44.38		
	Mid	3326.00	H	-55.51	12.95	-42.56	-13.00	PASS
		1673.00	Vertical	-36.75	4.52	-32.23		
		2509.50	V	-45.33	9.40	-35.93		
		3346.00	V	-51.17	13.00	-38.17		
		1673.00	Horizontal	-42.70	4.52	-38.18		
		2509.50	H	-52.66	9.40	-43.26		
	High	3346.00	H	-54.93	13.00	-41.93	-13.00	PASS
		1683.00	Vertical	-35.79	4.45	-31.34		
		2524.50	V	-43.68	9.41	-34.27		
		3366.00	V	-49.42	12.90	-36.52		
		1683.00	Horizontal	-44.04	4.45	-39.59		
		2524.50	H	-54.95	9.41	-45.54		
		3366.00	H	-57.18	12.90	-44.28	-13.00	PASS



10. ERP and EIRP

10.1. Test Standard and Limit

Applicable Standard:	Part 2.1046 Part 22.913(a) Part 24.232(b) Part 27.50(b) Part 27.50(c) Part 27.50(d) Part 90.635
Limit:	ERP ≤ 7W(38.45dBm) (LTE Band 5,26(824-849MHz)) EIRP ≤ 2W(33.00dBm) (LTE Band 2,25) ERP ≤ 3W(34.77dBm) (LTE Band 13) ERP ≤ 3W(34.77dBm) (LTE Band 12) EIRP ≤ 1W(30.00dBm) (LTE Band 4) ERP ≤ 100W(50.00dBm) (LTE Band 26(814-824MHz))

10.2. Test Setup

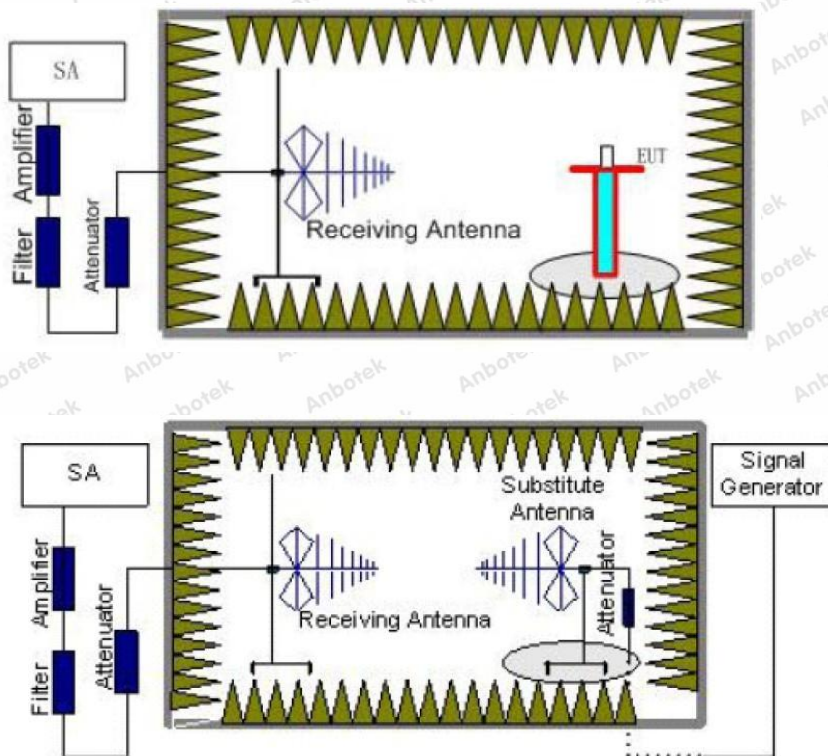

10.3. Test Procedure

1. Place the EUT in the center of the turntable.
 - a) For radiated emissions measurements performed at frequencies less than or equal to 1 GHz, the EUT shall be placed on a RF-transparent table at a nominal height of 80 cm above the reference ground plane
 - b) For radiated measurements performed at frequencies above 1 GHz, the EUT shall be placed on an RF transparent table at a nominal height of 1.5 m above the ground plane.
2. Unless the EUT uses an integral antenna, the EUT shall be terminated with a non-radiating transmitter load. In cases where the EUT uses an adjustable antenna, the antenna shall be adjusted through typical positions and lengths to maximize emissions levels.
3. The EUT shall be tested while operating on the frequency per manufacturer specification. Set the transmitter to operate in continuous transmit mode.
4. Receiver or Spectrum set as follow:
Below 1GHz, RBW=100kHz, VBW=300kHz, Detector=Peak, Sweep time=Auto
Above 1GHz, RBW=1MHz, VBW=3MHz, Detector=Peck, Sweep time=Auto
5. Each emission under consideration shall be evaluated:
 - a) Raise and lower the measurement antenna from 1 m to 4 m, as necessary to enable detection of the maximum emission amplitude relative to measurement antenna height.
 - b) Rotate the EUT through 360° to determine the maximum emission level relative to the axial position.
 - c) Return the turntable to the azimuth where the highest emission amplitude level was observed.
 - d) Vary the measurement antenna height again through 1 m to 4 m again to find the height associated with the maximum emission amplitude.
 - e) Record the measured emission amplitude level and frequency
6. Repeat step 5 for each emission frequency with the measurement antenna oriented in both the horizontal and vertical polarizations to determine the orientation that gives the maximum emissions amplitude.
7. Set-up the substitution measurement with the reference point of the substitution antenna located as near as possible to where the center of the EUT radiating element was located during the initial EUT measurement.
8. Maintain the previous measurement instrument settings and test set-up, with the exception that the EUT is removed and replaced by the substitution antenna.
9. Connect a signal generator to the substitution antenna; locate the signal generator so as to minimize any potential influences on the measurement results. Set the signal generator to the frequency where emissions are detected, and set an output power level such that the radiated signal can be detected by the measurement instrument, with sufficient dynamic range relative to the noise floor.
10. For each emission that was detected and measured in the initial test
 - a) Vary the measurement antenna height between 1 m to 4 m to maximize the received (measured) signal amplitude.
 - b) Adjust the signal generator output power level until the amplitude detected by the measurement instrument equals the amplitude level of the emission previously measured directly in step 5 and step 6.
 - c) Record the output power level of the signal generator when equivalence is achieved in step b).



11. Repeat step 8 through step 10 with the measurement antenna oriented in the opposite polarization.

12. Calculate the emission power in dBm referenced to a half-wave dipole using the following equation:

$$P_e = P_s(\text{dBm}) - \text{cable loss (dB)} + \text{antenna gain (dBd)}$$

where

P_e = equivalent emission power in dBm

P_s = source (signal generator) power in dBm

NOTE—dBd refers to the measured antenna gain in decibels relative to a half-wave dipole.

13. Correct the antenna gain of the substitution antenna if necessary to reference the emission power to a half-wave dipole. When using measurement antennas with the gain specified in dBi, the equivalent dipole-referenced gain can be determined from:

$$\text{gain (dBd)} = \text{gain (dBi)} - 2.15 \text{ dB.}$$

If necessary, the antenna gain can be calculated from calibrated antenna factor information

14. Provide the complete measurement results as a part of the test report.

10.4. Test Data

Pass

Please to see the following pages

LTE Band 2						
Bandwidth	Modulation	Channel	EIRP (dBm)		Limit (dBm)	Result
			Vertical	Horizontal		
1.4MHz	QPSK	Low	23.06	20.22	33.00	PASS
		Mid	23.49	20.09		
		High	23.59	20.36		
	16QAM	Low	17.05	14.91		PASS
		Mid	17.71	15.40		
		High	17.50	15.98		
3MHz	QPSK	Low	22.32	18.82	33.00	PASS
		Mid	23.02	20.05		
		High	22.80	19.80		
	16QAM	Low	19.02	16.93		PASS
		Mid	18.80	16.42		
		High	17.58	16.44		
5MHz	QPSK	Low	25.54	21.88	33.00	PASS
		Mid	25.91	21.47		
		High	26.54	21.89		
	16QAM	Low	19.82	16.50		PASS
		Mid	20.07	16.84		
		High	19.72	17.27		



LTE Band 4						
Bandwidth	Modulation	Channel	EIRP (dBm)		Limit (dBm)	Result
			Vertical	Horizontal		
1.4MHz	QPSK	Low	23.42	21.33	30.00	PASS
		Mid	24.18	21.98		
		High	24.45	21.61		
	16QAM	Low	18.50	17.72		PASS
		Mid	19.14	18.45		
		High	19.14	18.38		
3MHz	QPSK	Low	24.33	21.33	30.00	PASS
		Mid	23.99	21.45		
		High	23.76	21.28		
	16QAM	Low	19.13	18.68		PASS
		Mid	19.60	17.33		
		High	19.80	18.83		
5MHz	QPSK	Low	25.66	22.50	30.00	PASS
		Mid	26.00	23.10		
		High	26.21	22.81		
	16QAM	Low	20.17	18.54		PASS
		Mid	20.61	20.42		
		High	20.36	19.02		

LTE Band 5						
Bandwidth	Modulation	Channel	ERP (dBm)		Limit (dBm)	Result
			Vertical	Horizontal		
1.4MHz	QPSK	Low	23.13	21.98	38.45	PASS
		Mid	23.87	22.27		
		High	23.82	22.30		
	16QAM	Low	19.30	18.16		PASS
		Mid	19.51	18.88		
		High	19.62	18.45		
3MHz	QPSK	Low	25.62	20.90	38.45	PASS
		Mid	24.98	21.12		
		High	24.03	20.77		
	16QAM	Low	19.07	19.46		PASS



5MHz	QPSK	Mid	19.50	18.37	38.45	PASS		
		High	19.60	18.02				
		Low	24.68	21.50				
	16QAM	QPSK	Mid	24.34		21.73	38.45	PASS
			High	23.43		21.16		
			Low	20.38		19.52		
		16QAM	Mid	20.13		19.72		PASS
			High	20.02		19.53		
			Low	20.38		19.52		

LTE Band 12							
Bandwidth	Modulation	Channel	ERP (dBm)		Limit (dBm)	Result	
			Vertical	Horizontal			
1.4MHz	QPSK	Low	23.42	20.61	34.77	PASS	
		Mid	23.72	20.45			
		High	24.11	20.73			
	16QAM	Low	16.68	14.66		34.77	PASS
		Mid	17.23	15.19			
		High	17.28	15.81			
3MHz	QPSK	Low	22.60	19.04	34.77	PASS	
		Mid	23.19	20.41			
		High	23.22	20.09			
	16QAM	Low	18.89	16.92		34.77	PASS
		Mid	18.45	16.34			
		High	17.38	16.33			
5MHz	QPSK	Low	26.20	22.47	34.77	PASS	
		Mid	26.44	22.00			
		High	27.42	22.45			
	16QAM	Low	19.79	16.44		34.77	PASS
		Mid	19.87	16.80			
		High	19.77	17.26			

LTE Band 13						
Bandwidth	Modulation	Channel	ERP (dBm)		Limit (dBm)	Result
			Vertical	Horizontal		
5MHz	QPSK	Low	22.48	20.66	34.77	PASS
		Mid	22.79	20.58		



16QAM	High	22.78	20.76	PASS
	Low	17.81	16.54	
	Mid	18.30	16.93	
	High	18.05	17.36	

LTE Band 25						
Bandwidth	Modulation	Channel	EIRP (dBm)		Limit (dBm)	Result
			Vertical	Horizontal		
1.4MHz	QPSK	Low	22.96	20.13	33.00	PASS
		Mid	23.38	20.01		
		High	23.46	20.27		
	16QAM	Low	17.17	15.03		PASS
		Mid	17.82	15.49		
		High	17.60	16.05		
3MHz	QPSK	Low	22.25	18.79	33.00	PASS
		Mid	22.92	19.97		
		High	22.70	19.72		
	16QAM	Low	19.07	16.97		PASS
		Mid	18.86	16.48		
		High	17.68	16.49		
5MHz	QPSK	Low	25.34	21.73	33.00	PASS
		Mid	25.71	21.34		
		High	26.30	21.75		
	16QAM	Low	19.84	16.56		PASS
		Mid	20.09	16.87		
		High	19.73	17.29		

LTE Band 26 (814-824MHz)						
Bandwidth	Modulation	Channel	ERP (dBm)		Limit (dBm)	Result
			Vertical	Horizontal		
1.4MHz	QPSK	Low	22.69	19.91	50.00	PASS
		Mid	23.09	19.79		
		High	23.12	20.03		
	16QAM	Low	17.49	15.32		PASS
		Mid	18.09	15.73		
		High	17.85	16.23		



3MHz	QPSK	Low	22.05	18.70	50.00	PASS
		Mid	22.68	19.76		
		High	22.44	19.53		
	16QAM	Low	19.19	17.06		PASS
		Mid	19.02	16.62		
		High	17.92	16.63		
5MHz	QPSK	Low	24.83	21.35	50.00	PASS
		Mid	25.19	20.99		
		High	25.67	21.36		
	16QAM	Low	19.89	16.69		PASS
		Mid	20.13	16.97		
		High	19.77	17.35		

LTE Band 26 (824-849MHz)

Bandwidth	Modulation	Channel	ERP (dBm)		Limit (dBm)	Result
			Vertical	Horizontal		
1.4MHz	QPSK	Low	23.04	20.21	38.45	PASS
		Mid	23.49	20.12		
		High	23.62	20.40		
	16QAM	Low	17.01	14.88		PASS
		Mid	17.68	15.41		
		High	17.51	16.00		
3MHz	QPSK	Low	22.30	18.80	38.45	PASS
		Mid	23.01	20.08		
		High	22.83	19.83		
	16QAM	Low	18.98	16.90		PASS
		Mid	18.77	16.44		
		High	17.59	16.46		
5MHz	QPSK	Low	25.53	21.88	38.45	PASS
		Mid	25.92	21.51		
		High	26.58	21.94		
	16QAM	Low	19.79	16.47		PASS
		Mid	20.05	16.85		
		High	19.73	17.29		



11. Frequency stability VS Voltage measurement

11.1. Test Standard and Limit

Applicable Standard:	Part 2.1055(d)(1)(2) Part 22.355 Part 24.235 Part 27.54 Part 90.213
Limit:	$\leq \pm 2.5\text{ppm}$

11.2. Test Setup

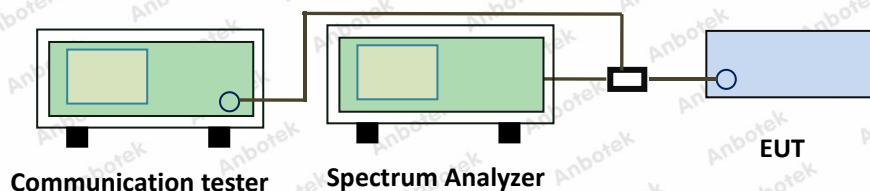

11.3. Test Procedure

1. The equipment under test was connected to an external DC power supply and input rated voltage.
2. The EUT output port was connected to communication tester.
3. The EUT was placed inside the temperature chamber at 25°C.
4. The power supply voltage to the EUT was varied $\pm 15\%$ of the nominal value measured at the input to the EUT.
5. Record the maximum frequency change.

11.4. Test Data

Pass

Please refer to Appendix F of the Appendix Test Data.



12. Frequency stability VS Temperature measurement

12.1. Test Standard and Limit

Applicable Standard:	Part 2.1055(a)(1)(b) Part 22.355 Part 24.235 Part 27.54 Part 90.213
Limit:	≤ ±2.5ppm

12.2. Test Setup

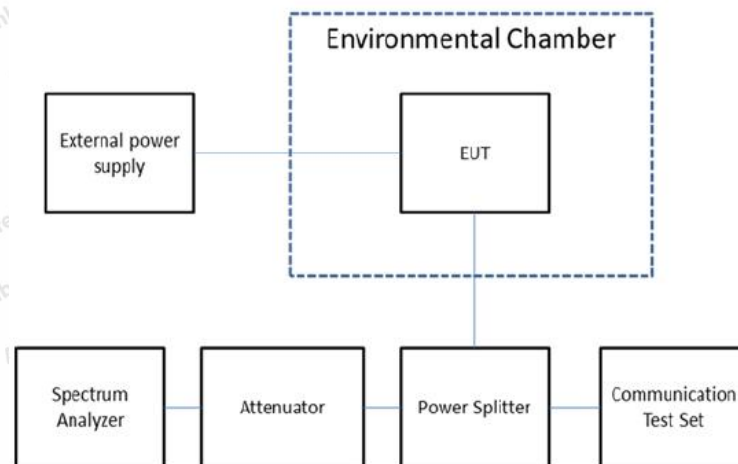

12.3. Test Procedure

1. The equipment under test was connected to an external DC power supply and input rated voltage.
2. The EUT output port was connected to communication tester.
3. The EUT was placed inside the temperature chamber.
4. Turn EUT off and set the chamber temperature to -30°C . After the temperature stabilized for approximately 30 minutes recorded the frequency.
5. Repeat step 4 measure with 10°C increased per stage until the highest temperature of $+50^{\circ}\text{C}$ reached.

12.4. Test Data

Pass

Please refer to Appendix G of the Appendix Test Data.



APPENDIX I -- TEST SETUP PHOTOGRAPH

Please refer to separated files Appendix I -- Test Setup Photograph

APPENDIX II -- EXTERNAL PHOTOGRAPH

Please refer to separated files Appendix II -- External Photograph

APPENDIX III -- INTERNAL PHOTOGRAPH

Please refer to separated files Appendix III -- Internal Photograph

----- End of Report -----

