

### Wireless Charging Stand

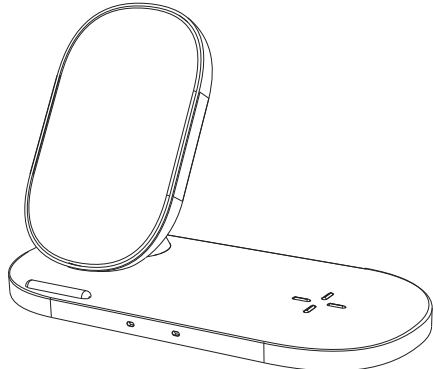

### User Manual

Model NO.: WCS07

Thanks for choosing our Wireless Charging Stand! This is a smartphone wireless charging Stand for iPhone 11Pro, iPhone 11, iPhone XS, iPhone XR Max, iPhone X, iPhone 8, iPhone 8 Plus, Samsung Galaxy S9,S9+,S8, S8+, Qi-enabled devices and other digital devices. Please kindly read the user manual before using.

#### Product Outline

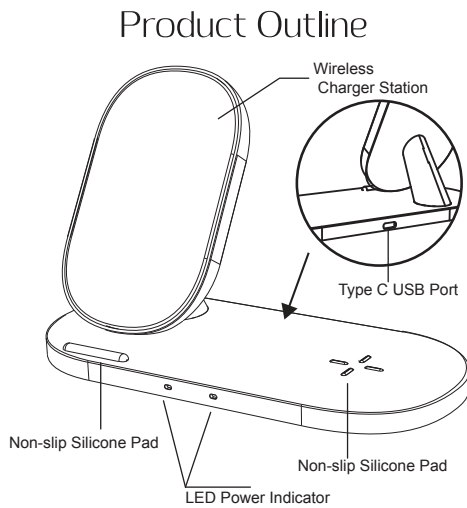

1.

### How to use

#### ■ Connect to power Adapter

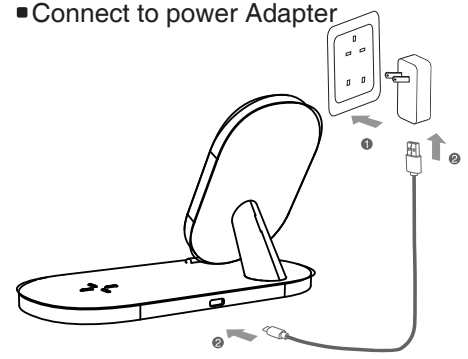

- ① Connect the power adapter to socket.
- ② Connect adapter to the USB 2.0 interface, the other TYPE-C USB to the Wireless Stand.

Note: Charging pad controlled by smart chips, long-term standby can be assured.

2.

#### ■ Connect to laptop for charging

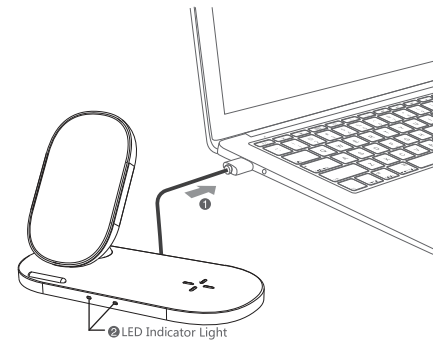

- ① Connect the USB 2.0 interface into laptop USB port, the other TYPE-C USB to the Wireless Stand.
- ② Standby LED light turn on red.

3.

#### ■ charging mode

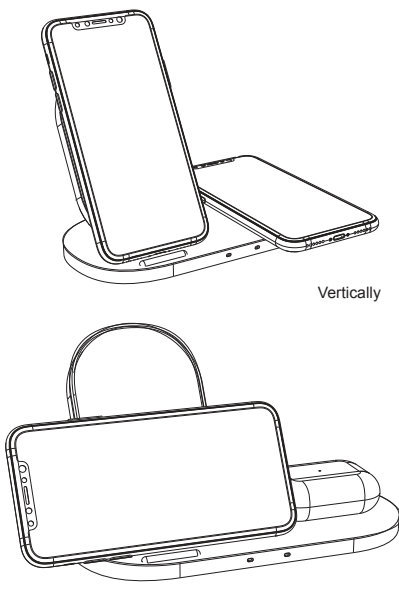

Vertically

Horizontally

LED indicator

1. Turn on: LED Red->Green->Red->Light off
2. Stand by: LED Light off
3. Charging: Green LED keep lightning on
4. FOD: Red LED blink

4.

### Product Specifications

- Standard: Qi wireless charging standard
- Input: DC9.0V = 2.0A(min) ;QC3.0,PD3.0 18W
- Transmission Power: 5W, 7.5W, 10W
- Transmission Distance: <8mm
- Conversion Efficiency: ≥72%
- Dimensions:180x86x111mm

### Products Supplied

- Wireless Charging Stand
- User Manual

#### IMPORTANT SAFETY INSTRUCTIONS

WARNING-When using this product, basic precautions should always be followed, including the following:

- a. Read the instructions before using the product.
- b. To reduce the risk of injury, close supervision is necessary when the product is used near children.
- c. Do not put fingers or hands into the product.
- d. Do not expose the product to rain or snow.
- e. Used of a power supply or charger not recommended or sold by product manufacturer may result in a risk of fire or injury to persons.
- f. Do not use the product in excess of its output rating. Overload outputs above rating may result in a risk of fire or injury to persons.
- g. Do not use the product that is damaged or modified. Damaged or modified batteries may exhibit unpredictable behavior resulting in fire, explosion or risk of injury

5.

- h. Do not disassemble the product. Take it to a qualified service person when services or repair is required. Incorrect reassemble may result in a risk of fire or injury to person.
- i. Do not expose product to fire excessive temperature. Exposure to fire or temperature above 100°C may cause explosion. The temperature of 100°C can be replaced by the temperature of 212°F.
- j. Have servicing performed by a qualified repair person using only identical replacement parts. This will ensure that the safety of the product is maintained.
- k. Switch off the product when not in use.

#### Caution and Safety

Do not expose to moisture, sunlight, or other heat sources. Keep away from children and ensure all adults who use this product read and follow these instructions and warnings. Operating temperature range between 32°F and 113°F. Use correct voltage charger, 5V only. Battery must be recycled or disposed of properly.



CAUTION : Risk of Fire and Burn. Do Not Open, Crush, Heat Above 45°C/113°F or incinerate. Follow Manufacturer's instructions.

6.

This device complies with Part 15 of the FCC Rules. Operation is subject to the following two conditions:(1)This device may not Cause harmful interference, and (2)This device must accept any interference received, including interference that may cause undesired operation.

This equipment has been tested and found to comply with the limits for a Class B digital device, pursuant to part 15 of the FCC Rules. These limits are designed to provide reasonable protection against harmful interference in a residential installation.

This equipment generates, uses, and can radiate radio frequency energy and, if not installed and used in accordance with the instructions, may Cause harmful interference to radio communications. However, there is no guarantee that interference will not occur in a particular installation. If this equipment does cause harmful interference to radio or television reception, which can be determined by turning the equipment off and on. The user is encouraged to try to correct the interference by one or more of the following measures:

- . Reorient or relocate the receiving antenna.
- . Increase the separation between the equipment and receiver.
- . Connect the equipment into an outlet on a circuit different from that to which the receiver is connected.
- . Consult the dealer or an experienced radio/TV technician for help.

#### FCC Radiation Exposure Statement

This equipment complies with FCC radiation exposure limits set forth for an uncontrolled environment. This equipment should be installed and operated with a minimum distance of 20 cm between the radiator and your body

7.