



ITM1188-F-XC User Manual

IEEE 802.11 b/g/n 2.4GHz 1T1R
USB Wi-Fi Module

Ver. 1.0

iotTech Corporation, Taiwan

Revision History

Date	Revision Content	Revised By	Version
2024/08/23	- Official released	Issac Chen	1.0
-	-		
-	-		
-	-		
-	-		
-	-		
-	-		
-	-		
-	-		

Contents

Revision History	2
Contents	3
1. General Description	4
2. Features	5
3. General Specification	6
3.1 Voltages.....	6
3.1.1 Absolute Maximum Ratings	6
3.1.2 Recommended Operating Ratings	6
3.2 Crystal Specification	6
3.3 Wi-Fi RF Specification (RX)	7
3.4 Wi-Fi RF Specification (TX)	8
3.5 Power Consumption	8
4. Antenna	9
5. Pin Assignments	11
5.1 PCB Pin Outline (13.0mmx12.2mmx1.8mm)	11
5.2 Pin Definition.....	12
6. PCB Layout	11
7. Dimensions	12
7.1 Layout Recommendation	12
8. Reference Design	13
9. Software Introduction	14
10. FCC Statement	19

1. General Description

The IoTech ITM1188-F-XC is a small size and low profile of WiFi module, board size is 12.2mm*13.0mm with module thickness of 1.7mm. It can be easily manufactured on SMT process and highly suitable for tablet PC, ultra-book, mobile device, and consumer products. It provides USB interface for WiFi to connect with host processor. The WiFi throughput can go up to 150Mbps in theory by using 1x1 802.11n b/g/n MIMO technology.

ITM1188-F-XC uses Realtek RTL8188FTV, a highly integrated WiFi single chip based on advanced CMOS process. RTL8188FTV integrates whole 2.4GHz 1T1R WiFi function blocks into a chip, such as USB, MAC, BB, AFE, RFE, PA, EEPROM and LDO/SWR, except fewer passive components remained on PCB.

ITM1188-F-XC block diagram is shown as below.

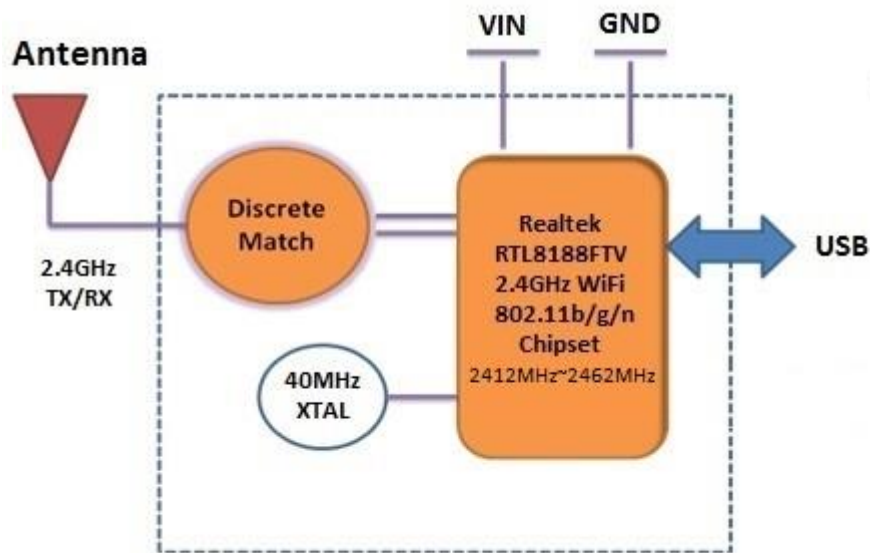

2. Features

- Operate at ISM frequency bands (2.4GHz)
- USB for Wi-Fi
- IEEE standards support: IEEE 802.11b, IEEE 802.11g, IEEE 802.11n, IEEE 802.11d, IEEE 802.11e, IEEE 802.11h, IEEE 802.11i
- Enterprise level security which can apply WPA/WPA2 certification for WiFi.
- WiFi 1 transmitter and 1 receiver allow data rates supporting up to 150 Mbps downstream and 150 Mbps upstream PHY rates

The general functional block diagram of RTL8188FTV chipset is shown as below.

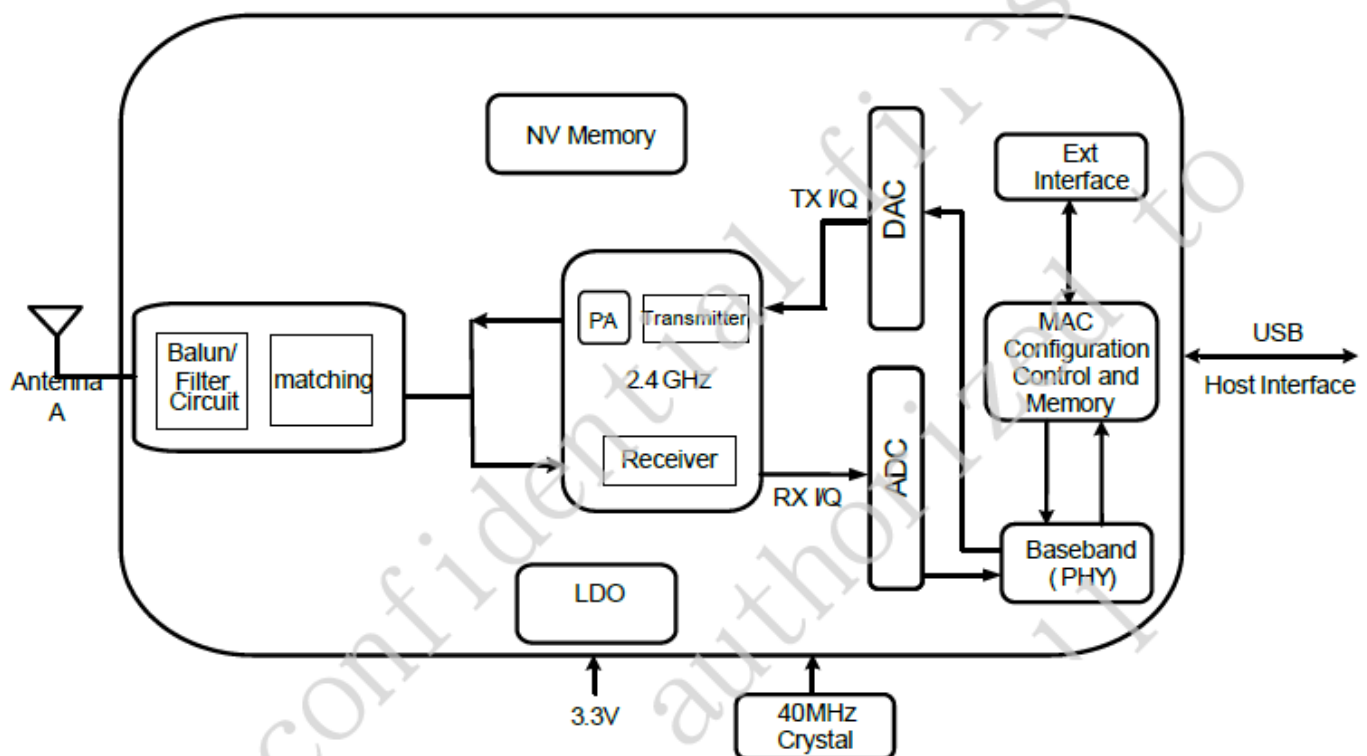

Figure 1. Single-Band 11n (1x1) Solution

3. General Specification

Operating temperature	-10°C to 70°C
Storage temperature	-40°C to 85°C

3.1 Voltages

3.1.1 Absolute Maximum Ratings

Symbol	Description	Min.	Max.	Unit
VIN	Input supply Voltage	-0.3	3.6	V

3.1.2 Recommended Operating Ratings

Test conditions: At room temperature				
Symbol	Min.	Typ.	Max.	Unit
VIN	3.15	3.3	3.45	V

Test conditions: At operating temperature 0°C ~70°C				
Symbol	Min.	Typ.	Max.	Unit
VIN	3.15	3.3	3.45	V

3.2 Crystal Specification

Parameters	Conditions	Min.	Typ.	Max.	Unit
Nominal Frequency			40		MHz
Load Capacitance			10		pF
Operating Temperature		-20		+75	°C
Frequency Tolerance	25°C ±3°C	-10		+10	ppm
Frequency Stability	Operating Temp. Range	-10		+10	ppm
Drive Level				100	uW
ESR				40	ohm

3.3 Wi-Fi RF Specification (RX)

Parameters	Conditions	Min.	Typ.	Max.	Unit
Frequency Range		2412		2462	MHz
RX Sensitivity 11b @ 8% PER	- 1Mbps		-91	-83	dBm
	- 2Mbps		-89	-80	dBm
	- 5.5Mbps		-87	-79	dBm
	- 11Mbps		-85	-76	dBm
RX Sensitivity 11g @ 10% PER	- 6Mbps		-87	-82	dBm
	- 9Mbps		-86	-81	dBm
	- 12Mbps		-84	-79	dBm
	- 18Mbps		-82	-77	dBm
	- 24Mbps		-79	-74	dBm
	- 36Mbps		-75	-70	dBm
	- 48Mbps		-71	-66	dBm
Receive Sensitivity (11n,20MHz) @10% PER	- MCS0		-87	-82	dBm
	- MCS=1		-84	-79	dBm
	- MCS=2		-82	-77	dBm
	- MCS=3		-79	-74	dBm
	- MCS=4		-75	-70	dBm
	- MCS=5		-71	-66	dBm
	- MCS=6		-70	-65	dBm
	- MCS=7		-69	-64	dBm
Receive Sensitivity (11n,40MHz) @10% PER	- MCS0		-84	-79	dBm
	- MCS=1		-81	-76	dBm
	- MCS=2		-79	-74	dBm
	- MCS=3		-76	-71	dBm
	- MCS=4		-72	-67	dBm
	- MCS=5		-68	-63	dBm
	- MCS=6		-67	-62	dBm
	- MCS=7		-66	-61	dBm
Maximum Receive Level	802.11b	-20	0		dBm
	802.11g	-20	0		dBm
	802.11n	-20	0		dBm

3.4 Wi-Fi RF Specification (TX)

Parameters	Conditions	Min.	Typ.	Max.	Unit
Frequency Range		2412		2462	MHz
Output Power	802.11b		15.26		dBm
	802.11g-6Mbps		18.52		dBm
	802.11n-MCS0		17.46		dBm
@EVM	802.11b / 11Mbps	--	-20	-10	dB
	802.11g / 54Mbps	--	-29	-25	dB
	802.11n / MCS7	--	-30	-28	dB

3.5 Power Consumption

TX Mode: (Continuous mode)	240mA (MCS7/BW40/13dBm)
RX Mode: (Conituous mode)	140mA (MCS7/BW40/-60dBm)
Associated Idle power saving with DTIM=3	2.1mA
Unassociated Idle:	0.1mA
RF disable Mode:	0.1mA

(Typical by using LDO)

4. Antenna

This module has been approved to operate with the antenna type listed below, with the maximum permissible gain indicated.

Part Number	Frequency Band	Antenna Type	Gain(dBi)
Hantech HT870001	2400~2500MHz	PIFA	3.0

Return Loss:

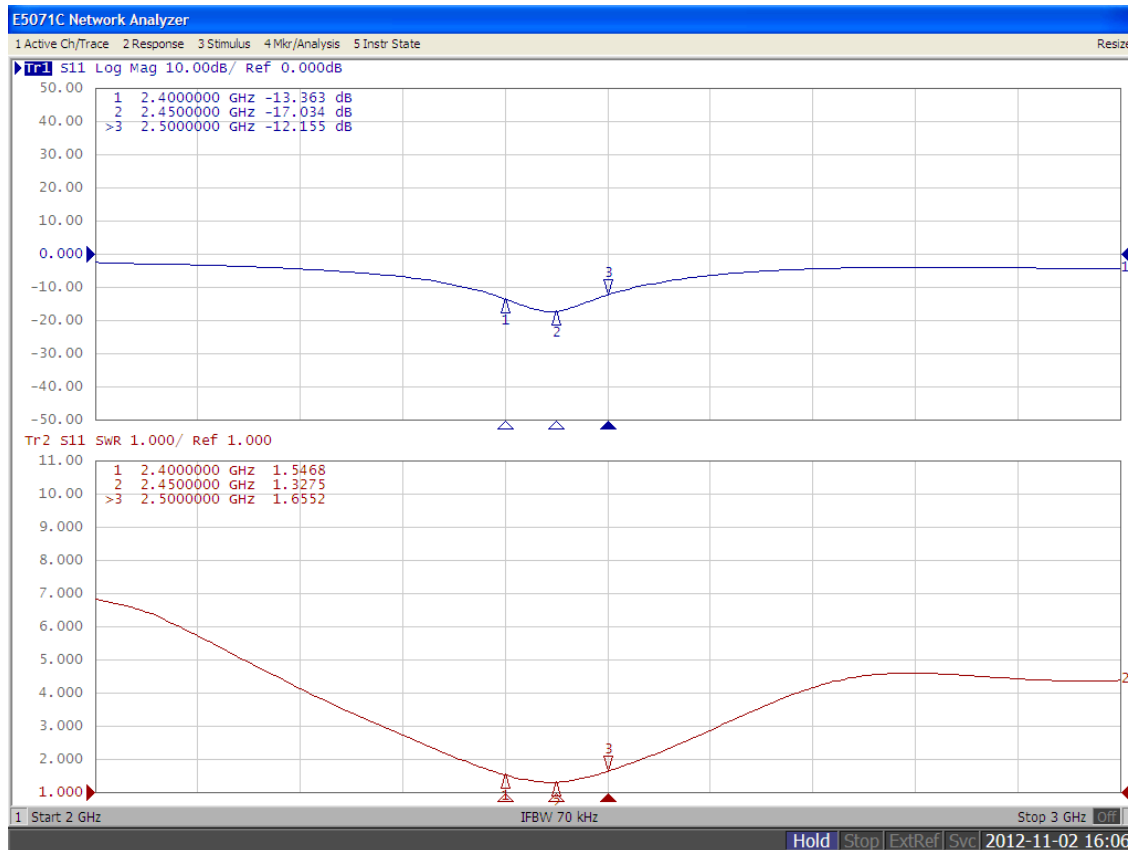

2400MHz:

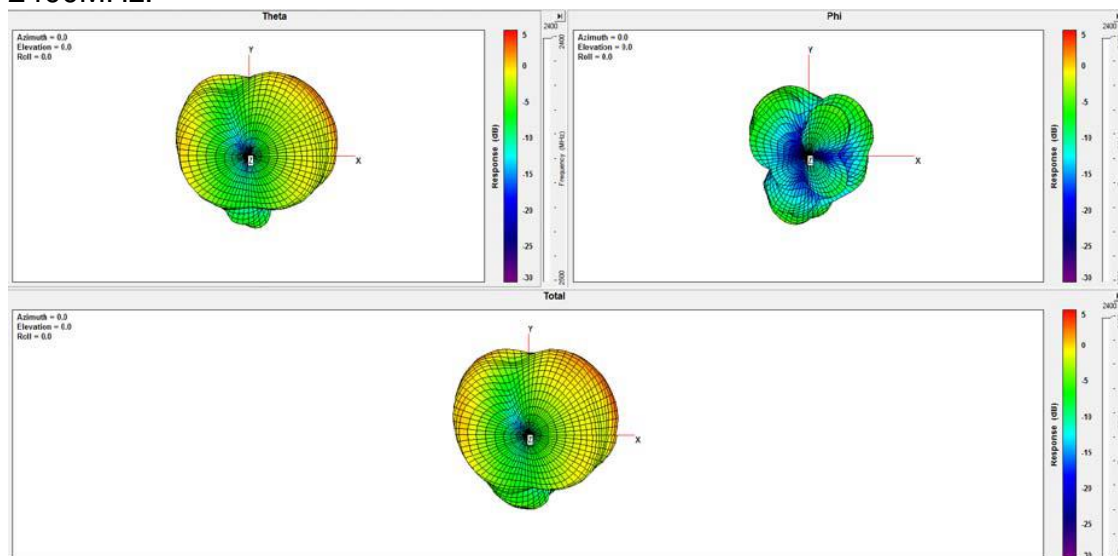

2450MHz:

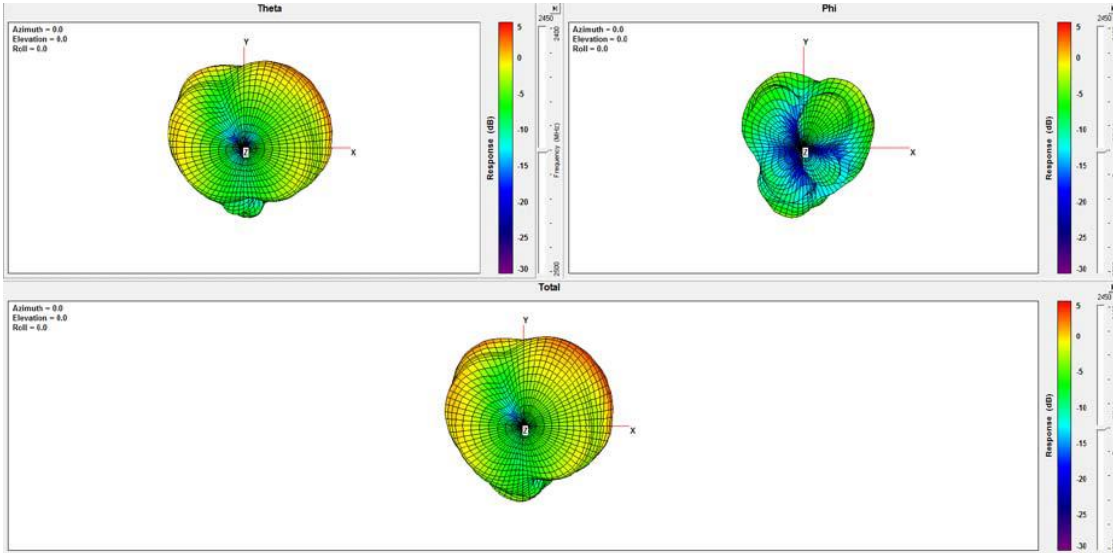

2500MHz:

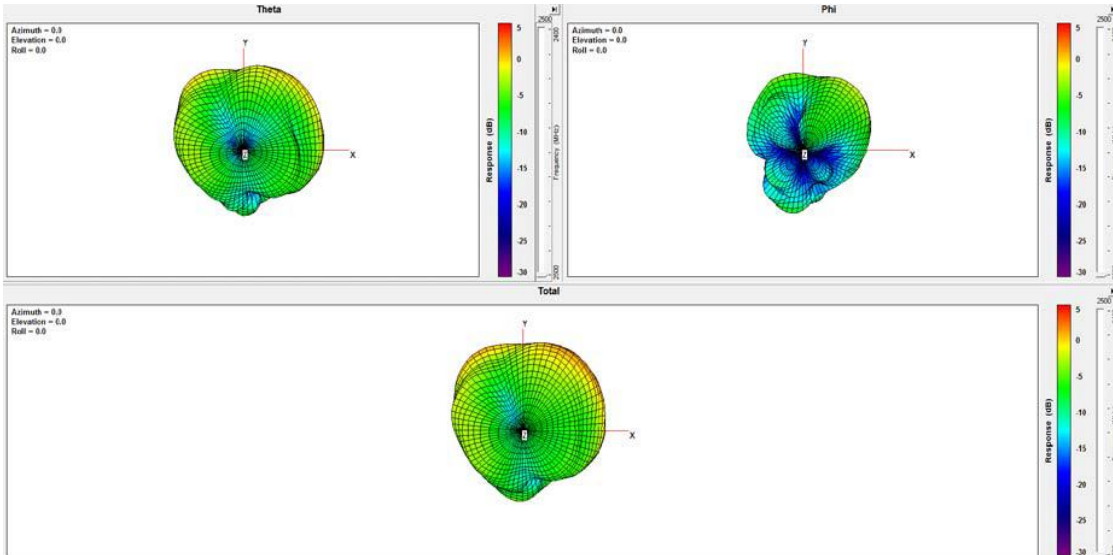

Gain/Efficiency:

Frequency(MHz)	2400	2410	2420	2430	2440	2450	2460	2470	2480	2490	2500
Gain (dBi)	2.77	3.00	3.16	3.23	3.16	3.44	3.36	3.48	3.59	3.55	3.44
Directivity (dBi)	5.62	5.74	5.72	5.65	5.51	5.58	5.64	5.81	5.93	6.10	6.20
Efficiency (dB)	-2.85	-2.74	-2.56	-2.42	-2.35	-2.14	-2.28	-2.32	-2.34	-2.55	-2.76
Efficiency (%)	56.85	58.24	60.46	62.28	63.25	66.05	64.14	63.57	63.30	60.55	57.92

5. Pin Assignments

5.1 PCB Pin Outline (13.0mmx12.2mmx1.8mm)

< TOP VIEW >

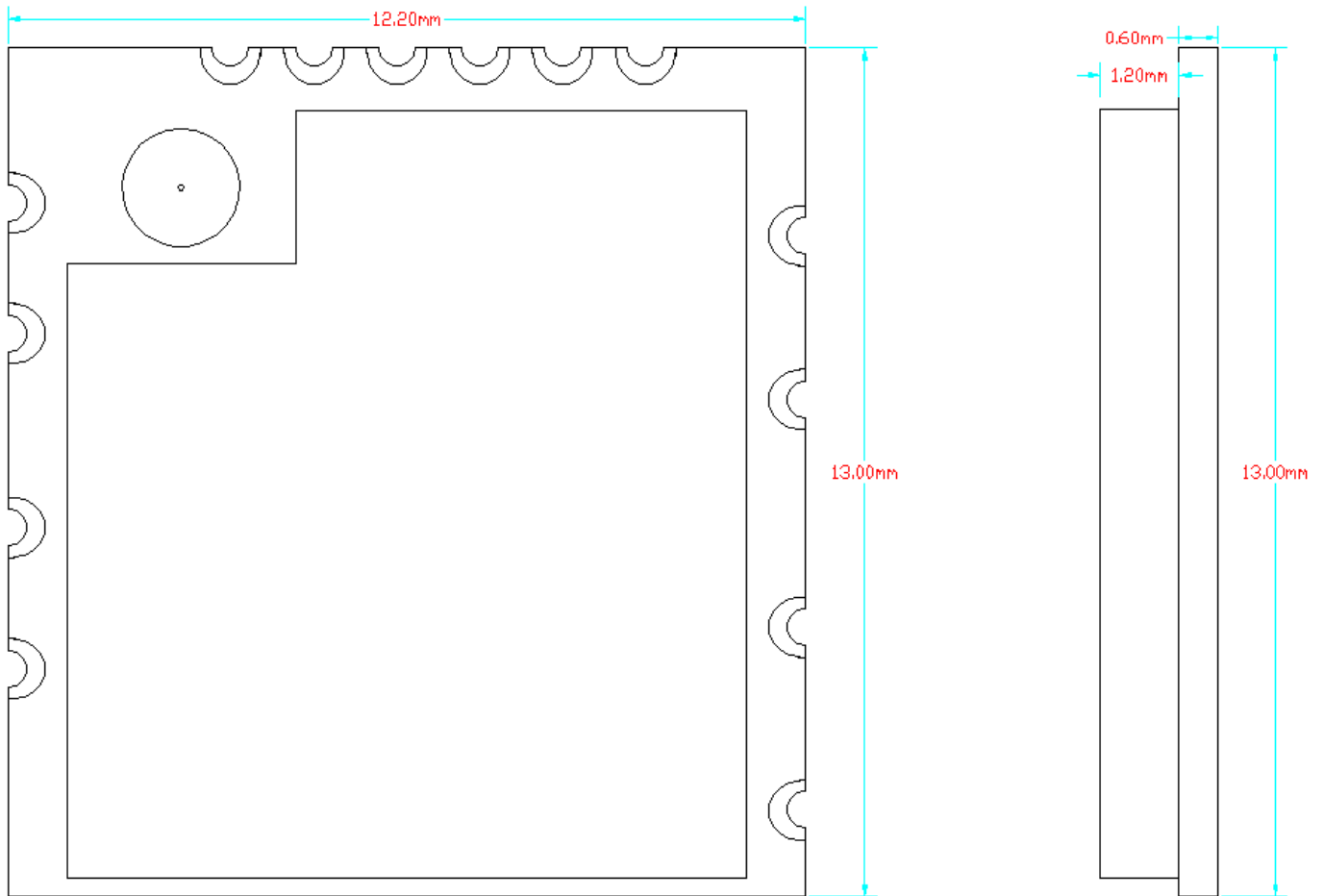

5.2 Pin Definition

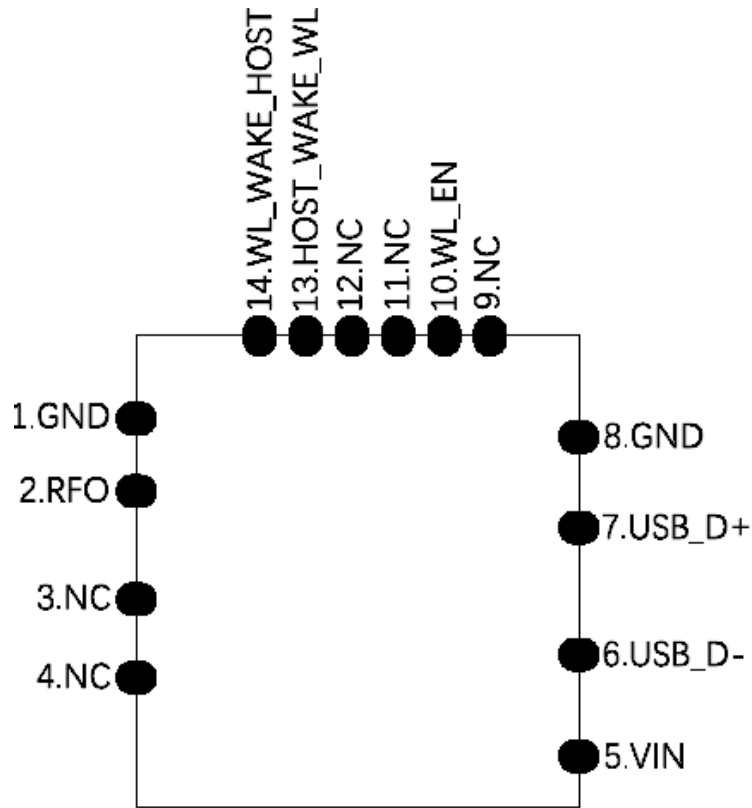

PIN Assignment

Pin #	Name	Description
1	GND	Ground
2	NC (RFO)	Floating (RF I/O pin, not used for this model)
3	NC	Floating (NC)
4	NC	Floating (NC)
5	VIN	Main power voltage source input
6	USB_D-	USB_D-
7	USB_D+	USB_D+
8	GND	Ground
9	NC	Floating (NC) if not used
10	NC (WL_EN)	Floating (WLAN enable/disable) if not used
11	NC	Floating (NC) if not used
12	NC	Floating (NC) if not used
13	NC (HOST_WAKE_WL)	Floating (Host wake up WLAN device) if not used
14	NC (WL_WAKE_HOST)	Floating (WLAN device wake up host) if not used
Total	14PINS	13.0*12.2*1.8mm Package

6. PCB Layout

Layer 1 (Top)

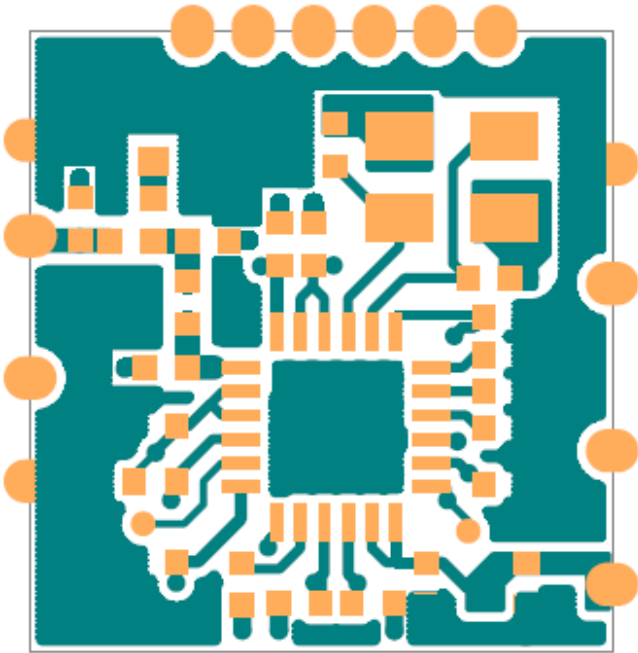

Layer 2

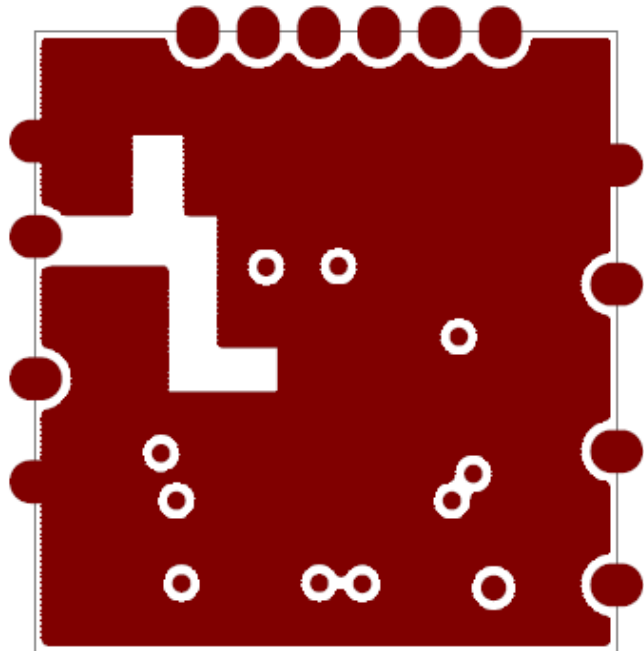

Layer 3

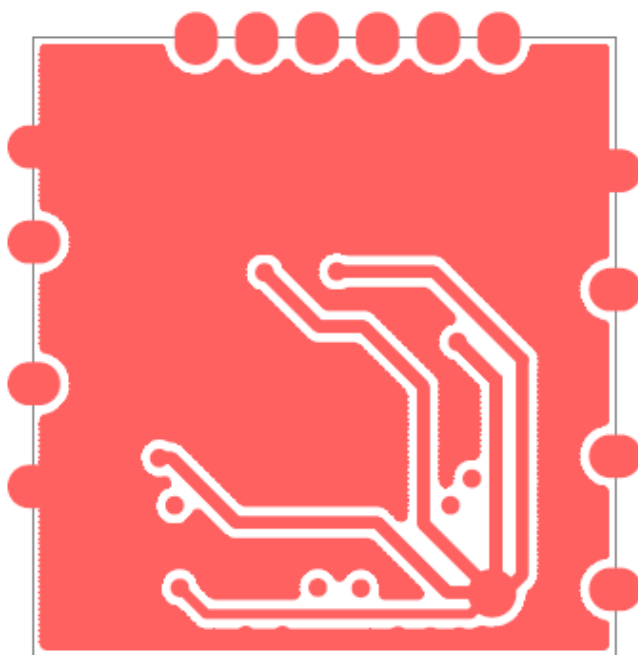

Layer 4 (Bottom)

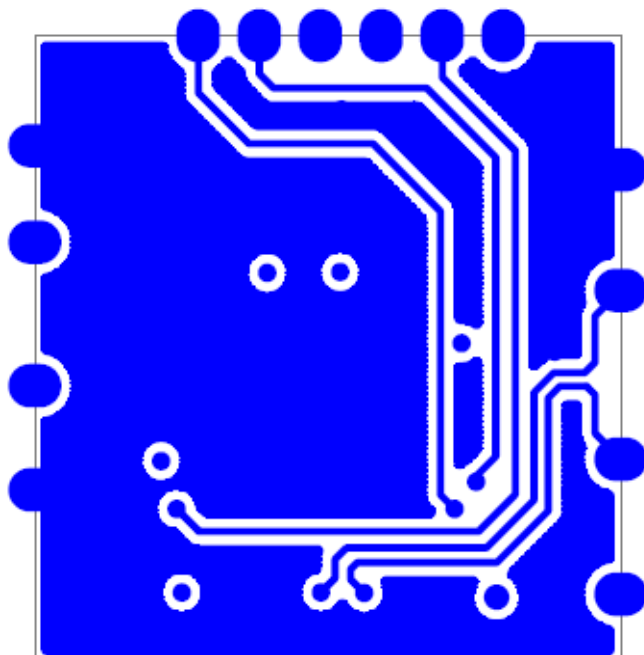

7. Dimensions

7.1 Layout Recommendation

(Unit: mm)

< TOP VIEW >

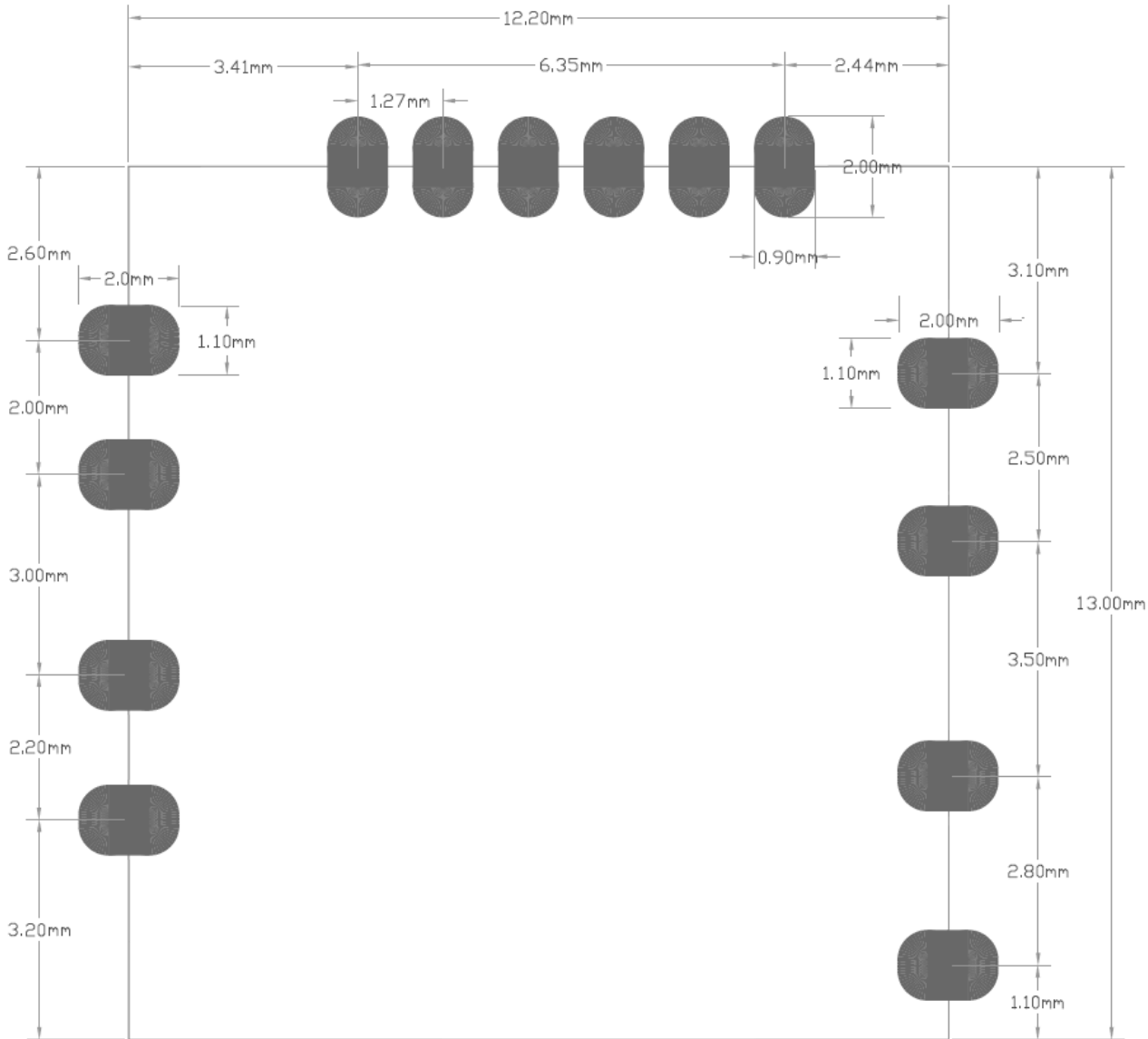

8. Reference Design

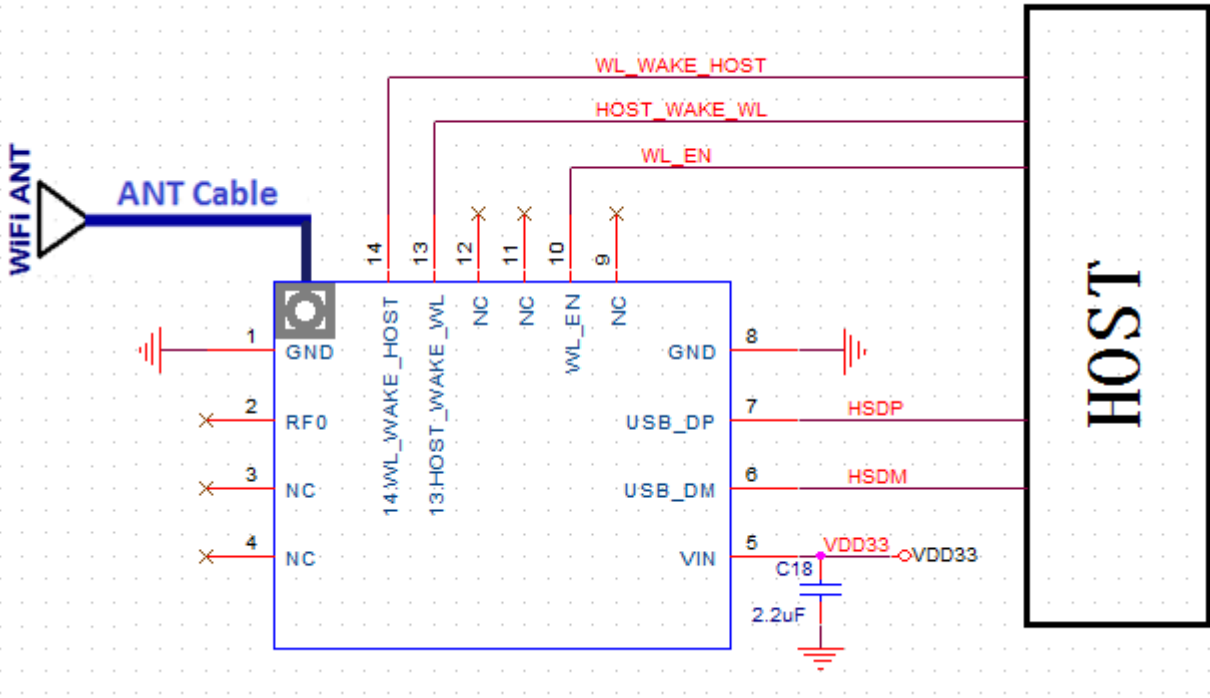

* Pin 10/13/14 are optional and should not be connected or grounded if not used.

Micro Coaxial Connector on ITM1188F-XC for External Antenna:

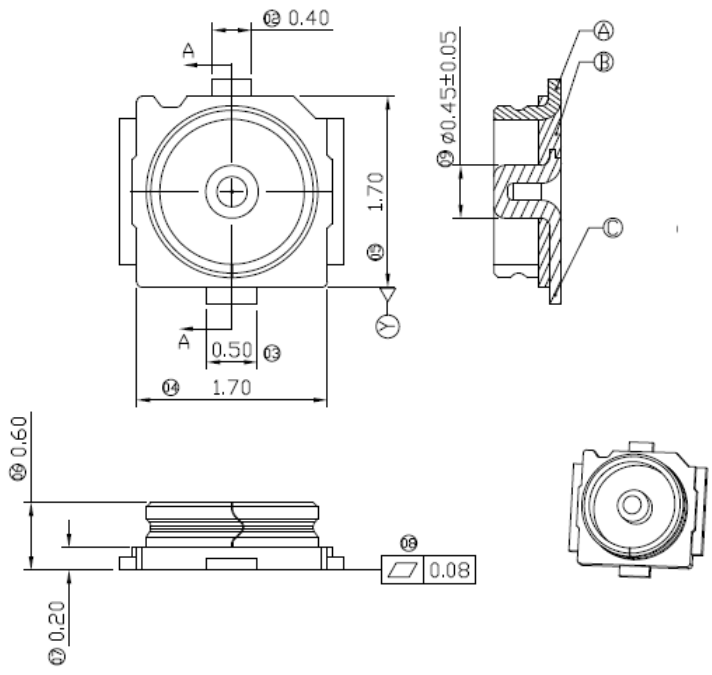

iotTech Corporation, Taiwan

9. Software Introduction

Installation of software driver is required before applying ITM1188-F-XC in Windows platforms. Here shows how to install software on Windows 10&7 64-bit platform.

1. Download the Realtek driver update from the Realtek website, or Microsoft Update link.
2. Press Windows + X > Device Manager



3. Head to the Network adapter > double click & expand it > look for 802.11 n USB Wireless LAN card > right-click Update driver.

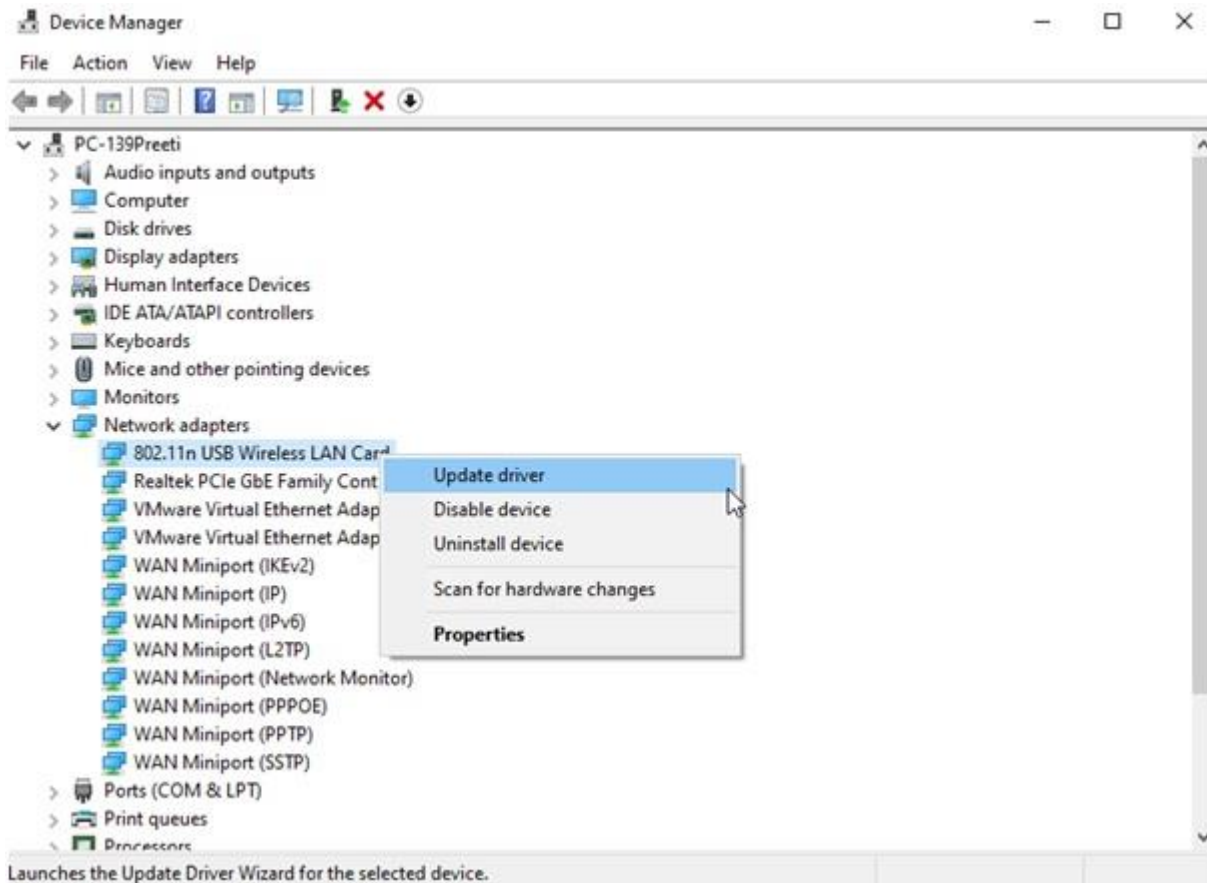

4. Click Search automatically for drivers to update 802.11 N driver.

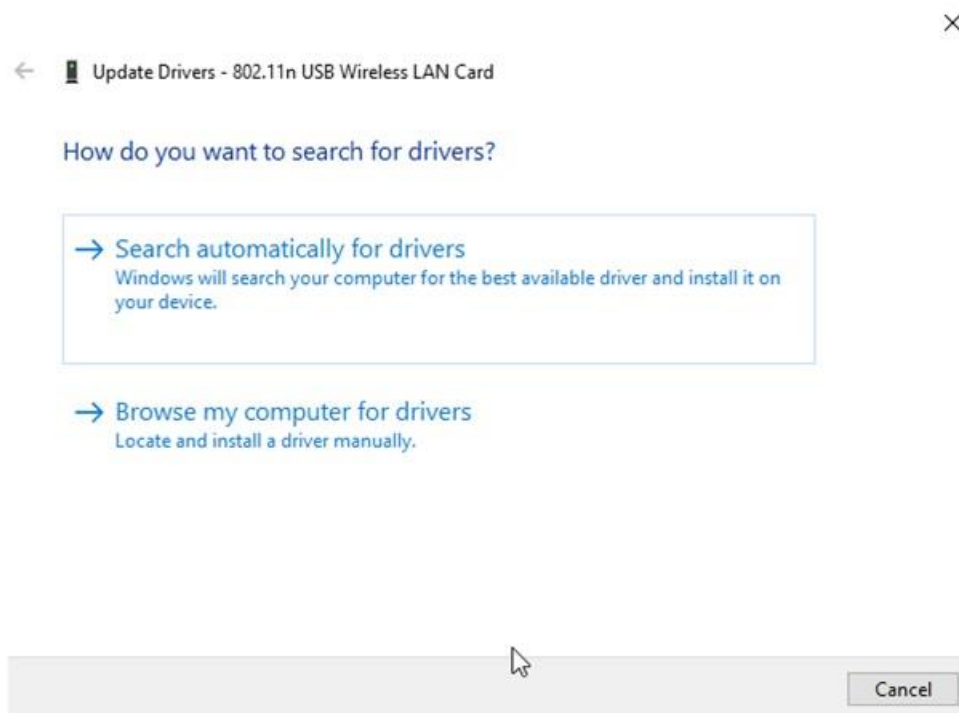

5. If you see the message below, click Search for updated drivers on Windows update.



6. Check for Windows updates and install them if available.

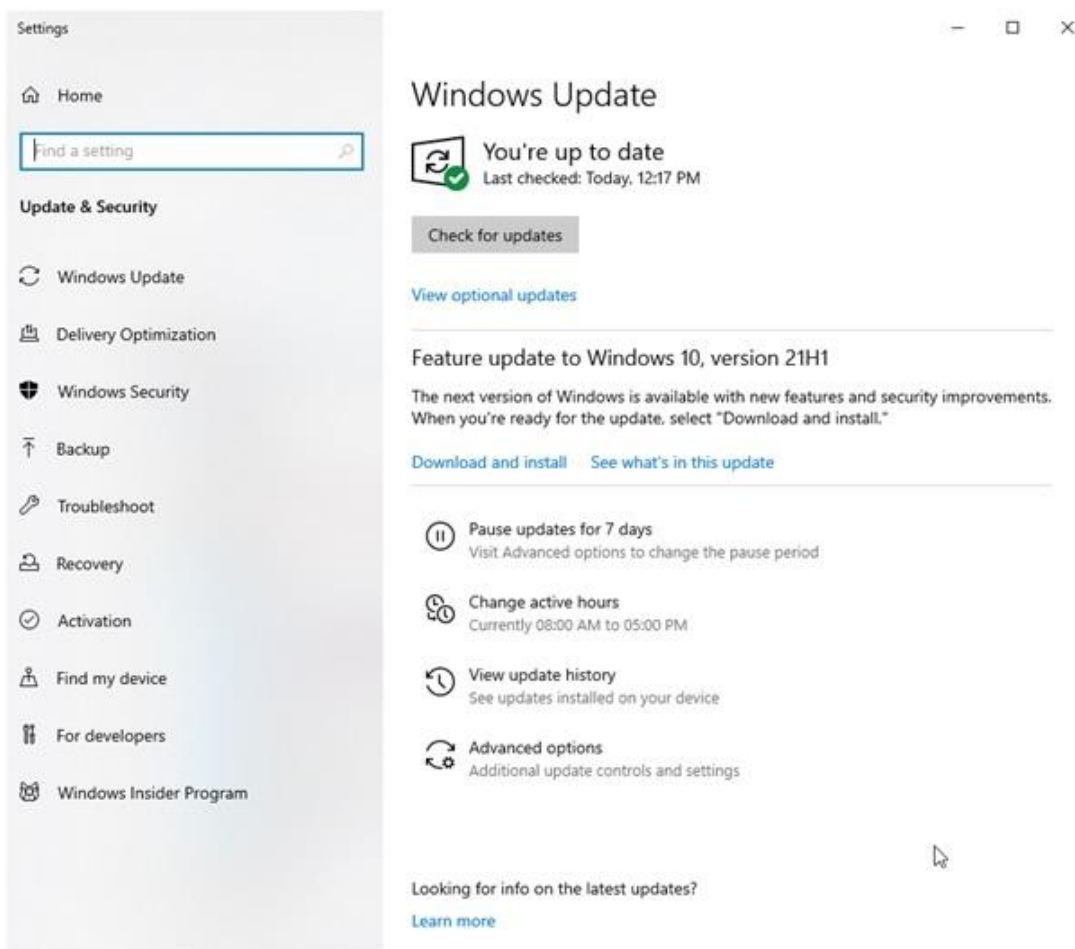

7. If the latest version is installed, click View options updates

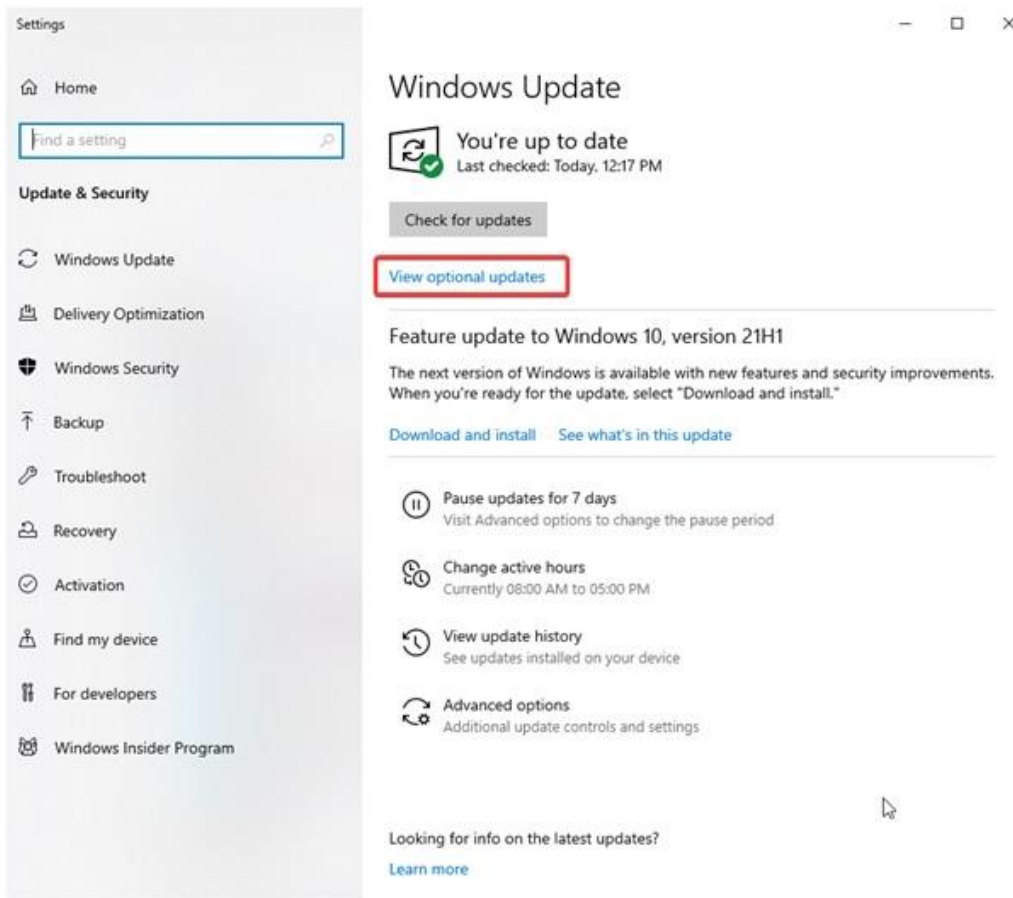

8. Double click Driver Update > check for Realtek update > Download and install.

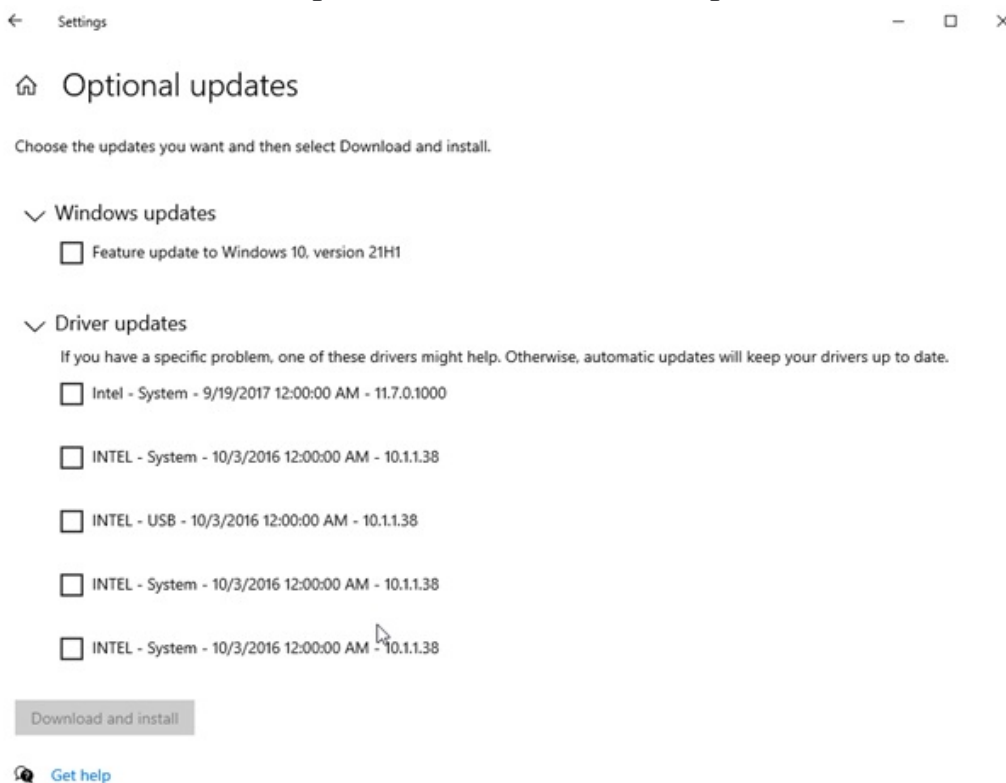

9. Restart the system to finish installing Realtek 802.11 n WLAN adapter driver Windows 10 64 bit. Now check if you can connect to the network.

10. FCC Statement

Compliance with

2.2 List of applicable FCC rules

CFR 47 FCC PART 15 SUBPART C has been investigated. It is applicable to the modular transmitter

2.3 Specific operational use conditions

This module is stand-alone modular. If the end product will involve the Multiple simultaneously transmitting condition or different operational conditions (example, uses another antenna) for a stand-alone modular transmitter in a host, host manufacturer have to consult with module manufacturer for the installation method in end system.

2.4 Limited module procedures

This module is single modular.

Not applicable.

2.5 Trace antenna designs

Not applicable.

2.6 RF exposure considerations

This modular transmitter should be used in the mobile conditions and 20cm from a person's body, the host product manufacture should be put those information in the end-product manual to the end users. If RF exposure statement and use conditions are not provided, then the host product manufacture is required to take responsibility of the module through a change in FCC ID(new application)

2.7 Antennas

This radio transmitter FCC ID : 2AWP5WM1188FXC and has been approved by Federal Communications Commission to operate with the antenna types listed below, with the maximum permissible gain indicated. Antenna types not included in this list that have a gain greater than the maximum gain indicated for any type listed are strictly prohibited for use with this device.

Manufacturer	Part No.	Antenna Type	Maximum antenna gain
Hantech	HT870001	Flexible PCB PIFA antenna	3.44 dBi @ 2450 MHz

2.8 Label and compliance information

The final end product must be labeled in a visible area with the following" Contains FCC ID: 2AWP5WM1188FXC.

2.9 Information on test modes and additional testing requirements

Host manufacturer which install this modular with limit modular approval should perform the test of radiated emission and spurious emission according to FCC part 15 :15.212 requirement, only if the test result comply with FCC part 15.212 requirement, then the host can be sold legally. When testing host product, the host manufacture should follow FCC KDB Publication 996369 D01 Module Integration Guide for testing the host products. The host manufacturer may operate their product during the measurements.

2.10 Additional testing, Part 15 Subpart B disclaimer

Host manufacturer is responsible for compliance of the host system with module installed with all other applicable requirements for the system such as Part 15 B.

Federal Communication Commission Interference Statement

This equipment has been tested and found to comply with the limits for a Class B digital device, pursuant to Part 15 of the FCC Rules. These limits are designed to provide reasonable protection against harmful interference in a residential installation. This equipment generates, uses and can radiate radio frequency energy and, if not installed and used in accordance with the instructions, may cause harmful interference to radio communications. However, there is no guarantee that interference will not occur in a particular installation. If this equipment does cause harmful interference to radio or television reception, which can be determined by turning the equipment off and on, the user is encouraged to try to correct the interference by one of the following measures:

- Reorient or relocate the receiving antenna.
- Increase the separation between the equipment and receiver.
- Connect the equipment into an outlet on a circuit different from that to which the receiver is connected.
- Consult the dealer or an experienced radio/TV technician for help.

FCC Caution:

Any changes or modifications not expressly approved by the party responsible for compliance could void the user's authority to operate this equipment.

This device complies with Part 15 of the FCC Rules. Operation is subject to the following two conditions:

- (1) This device may not cause harmful interference, and
- (2) This device must accept any interference received, including interference that may cause undesired operation.

IMPORTANT NOTE:

In the event that these conditions can not be met (for example certain laptop configurations or co-location with another transmitter), then the FCC authorization is no longer considered valid and the FCC ID can not be used on the final product. In these circumstances, the OEM integrator will be responsible for re-evaluating the end product (including the transmitter) and obtaining a separate FCC authorization.

End Product Labeling:

The final end product must be labelled in a visible area with the following:

【Contains FCC ID: 2AWP5WM1188FXC】

Manual Information to the End User

The OEM integrator has to be aware not to provide information to the end user regarding how to install or remove this RF module in the user's manual of the end product which integrates this

iotTech Corporation, Taiwan

module.