

3.1101.615717.0000000

原材料 机乐堂 JR-ZS290 流光磁吸无线充支架（出风口款）-说明书

尺寸：60x90mm

材质：128g铜版纸+正反单色印刷+风琴折

JOYROOM

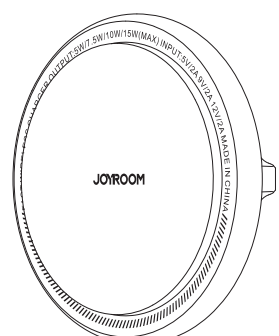

User Manual
Magnetic Wireless Car Charger Holder

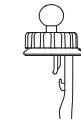

Parameters

Model	JR-ZS290
Name	Magnetic Wireless Car Charger Holder
Material	ABS+Metal
Input	5V ≍ 2A 9V ≍ 2A 12V ≍ 1.5A
Output	5W/7.5W/10W/15W (MAX)
Input port	Type-C
Applicable phone size	4.7-6.7"

Indicator light

Power on	LED letters light up respectively
Standby	Constant LED letters
Charging	LED letters turn off
FOD	Flashing LED letters

Product diagram

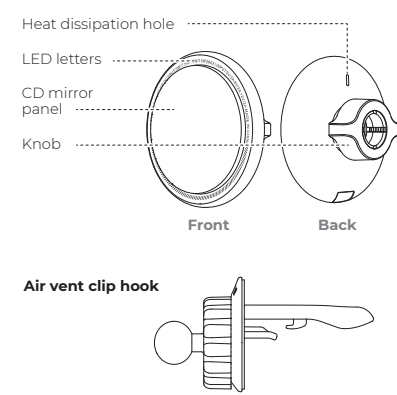

Operation steps

- Put the ball head into the nut first, then insert it into the socket on the back of the holder, tighten the nut clockwise.
- Loosen the knob and open the hook, insert the hook onto vent blade, then fasten the knob.
- Use the Type-C charging cable in the package to connect the holder and the car charger.
- Place your phone. It will be securely attached to the charger holder with its auto alignment function.

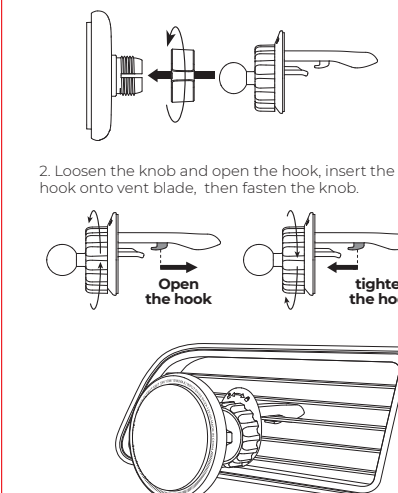

Note:

The product will automatically hold and charge your iP 12/13 once sensing it. If you don't want to take off your phone case, we suggest using magnetic cases.

Warning

- Do not disassemble or refit the product.
- Do not store it in a wet environment.
- Please keep the product away from heat and do not charge it near a heat source.
- Please prevent water or other liquid from entering the product interface. Otherwise the product may be damaged.
- Do not install the wireless car charger holder over an air bag cover or within the air bag deployment zone.
- During charging, make sure to remove the metallic/magnetic protective case or cards (like bank cards), etc. from your device.
- During charging, the charger may heat up. This is a normal occurrence and won't affect the its performance. If the charger or your phone gets too hot, please disconnect the power supply and let it cool down before restarting the charging process.
- Avoid using bent or damaged USB cables.

Warranty

A. If there is performance failure on this product and it's not cause by human error, we will provide 12-month free warranty service for consumers from the date of purchase.

B. Warranty Exceptions:

- Human damage;
- Beyond the warranty period;
- Failure to provide valid purchase certificate;
- Product damage caused by failure to follow the use, maintain and storage instructions;
- Product damage caused by disassembling or repairing the product without authorization, or immerse the product in water;
- Damage caused by other force majeure

Warranty Card	
Model:	Customer Name:
Purchase Date:	Tel.:
Distributor:	Invoice Date:
User address (with postcode):	

JOYROOM

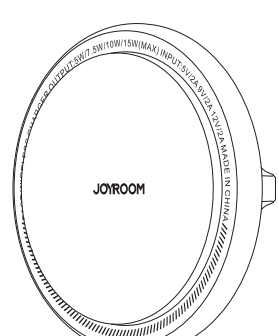

使用说明书
流光磁吸无线充支架

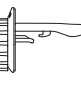

使用说明书

产品型号	JR-ZS290
产品名称	流光磁吸无线充支架
产品材质	ABS+金属
输入	5V ≍ 2A 9V ≍ 2A 12V ≍ 1.5A
输出	5W/7.5W/10W/15W (MAX)
输入接口	Type-C
适用尺寸	4.7-6.7英寸

灯显

通电	字符灯堆叠亮起
待机	字符灯常亮
充电:	字符灯灭
异物检测	字符灯闪烁

产品示意图

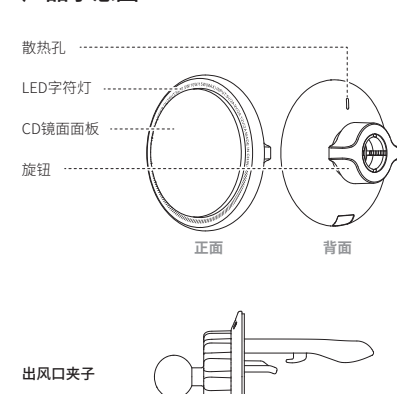

安装使用

- 将配件的滚球部位穿过旋钮插入产品背部螺栓，顺时针旋转旋钮拧紧。
- 逆时针旋转旋钮，展开挂钩，将挂钩插入出风口勾住叶片，然后顺时针旋转旋钮，收紧挂钩。
- Type-C 充电线插入产品充电口，连接车载充电器接通电源。
- 手机靠近无线充支架，磁性吸附，开始充电。

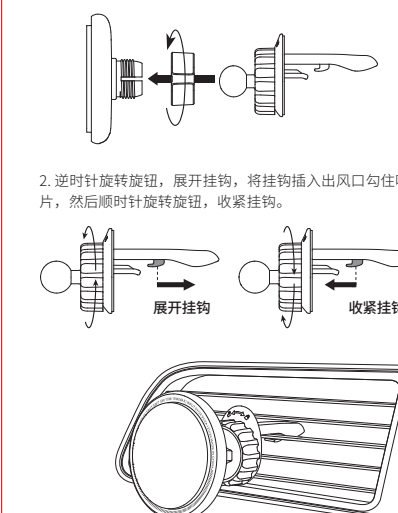

提示:

苹果12/13手机如果带壳使用的话，请使用磁吸壳。

警告

- 请勿自行拆开或改装本产品；
- 请勿将本产品放在潮湿环境中；
- 请勿将本产品靠近热源或于热源附近充电；
- 请勿将水或其他液体流入本产品介面内部，导致本产品损坏；
- 不要将无线充电器安装在气囊盖上或安全气囊展开区域；
- 充电时请务必从你的手机设备上取下金属磁性保护外壳或卡（如银行卡等）；
- 充电时有可能产生热量，此乃正常现象，并不会影响产品表现，如果感到手机或本产品过热请断开电源供应，待冷却后再尝试充电；
- 避免使用折曲或损坏的USB线材。

售后服务说明

尊敬的用户，非常感谢您使用我们的产品。为了切实保障您的权益，明确经销商和代理商应当承担产品的维修、更换、退货（简称三包）责任义务，敬请阅读以下事项：

- 产品保修卡，是我公司对其产品提供保修期内免费售后服务的必要凭证。
- 按照销售谁负责三包原则，产品出现质量问题凭（产品保修卡）与经销商联系，由经销商对客户提供服务，我公司则对经销商提供服务支持。
- 公司承诺，自售出之日（日期以有效，票据日期为准）起七日内出现质量问题，客户可以选择退货更换及维修，产品超过保修期出现质量问题享受终身维修（各售后服务点只收取元器件材料费）；请客户在购买时与经销商认真填好（产品保修卡）；
- 下列情形不享受三包服务
 - 超过三包期限的
 - 未按产品使用说明书要求使用、维修、保管而造成损坏的
 - 非承担三包的维修者拆动造成损坏的
 - 无（产品保修卡）
 - （产品保修卡）上的内容与产品实物不符或涂改的
 - 因不可抗力造成的
- 以上各事项最终解释权属于本公司所有！

保修卡	
产品型号:	用户姓名:
购买日期:	用户电话:
代理商:	发票日期:
用户地址 (含邮编):	

FCC statement:

This device complies with Part 15 of the FCC rules. Operation is subject to the following two conditions: 1) this device may not cause harmful interference, and 2) this device must accept any interference received, including interference that may cause undesired operation.

Note: This equipment has been tested and found to comply with the limits for a Class B digital device, pursuant to part 15 of the FCC Rules. These limits are designed to provide reasonable protection against harmful interference in a residential installation.

This equipment generates uses and can radiate radio frequency energy and, if not installed and used in accordance with the instructions, may cause harmful interference to radio communications. However, there is no guarantee that interference will not occur in particular installation. If this equipment does cause harmful interference to radio or television reception, which can be determined by turning the equipment off and on, the user is encouraged to try to correct the interference by one or more of the following measures:

- Reorient or relocate the receiving antenna.
- Increase the separation between the equipment and receiver.
- Connect the equipment into an outlet on a circuit different from that to which the receiver is connected.
- Consult the dealer or an experienced radio/TV technician for help.

Changes or modifications not expressly approved by the party responsible for compliance could void the user's authority to operate the equipment.

Radiation Exposure Statement

This device complies with FCC RF radiation exposure limits set forth for an uncontrolled environment. This transmitter must not be co-located or operating in conjunction with any other antenna or transmitter. During the operation of device a distance of 15 cm surrounding the device and 20 cm above the top surface of the device must be respected.