

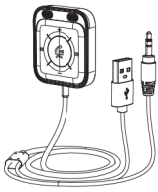





原材料 机乐堂 JR-CB3 蓝牙接收器 说明书  
 尺寸: 60x75mm  
 材质: 128g铜版纸+正反单色印刷+风琴折

<p><b>JOYROOM</b></p>  <p><b>User Manual</b> 2-in-1 Wireless Transmitter/Receiver</p>	<p><b>Basic parameters</b></p> <p>Name: Wireless Receiver                  Model: JR-CB3                  BT version: V5.3                  Audio decoding: SBC                  Supported protocols: HSP, HFP, A2DP, AVRCP                  Supported modes: BT, TF, TF card                  Transmission range: 12m                  Frequency response range: 20Hz-20KHz                  Mic sensitivity: -38±2dB                  Product input: 5V/1A                  Input port: USB-AUX                  Product size: 40±0.5mm x 45.7mm x 11.4mm                  Product material: ABS+PC                  Net weight: &lt;0g</p> <p><b>Packing list</b></p> <p>Wireless receiver    Manual &amp; Warranty Card</p> 	<p><b>Product diagram</b></p>  <p><b>Pairing operation</b></p> <ol style="list-style-type: none"> <li>1. Insert the USB connector of the receiver into a power supply, the light ring will light up which means the receiver is turned on.</li> <li>2. Plug the 3.5mm audio cable of the receiver into the 3.5mm port of the car audio system.</li> </ol> 	<p>3. Turn the phone's BT function on, search for the BT device "JR-CB3", click to pair and connect with it.</p> <p>4. After connecting successfully, you can start to use the receiver to enjoy music or answer calls.</p>  <p><b>Operation instructions</b></p> <p><b>1. Turn on/off</b></p>  <p>5min Turn off The receiver will turn off automatically if not connected for 5 minutes</p>	<p><b>2. Music function</b></p> <p><b>Play/Pause:</b> Click the source/play button</p>  <p><b>3. Voice assistant</b></p> <p>"di-di" Press and hold the call button for 2s, and then release after hearing a "di-di" sound</p>
--	---	--	--	--

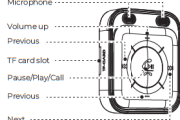
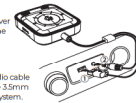
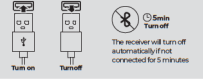
<p><b>4. Call function</b></p> <p><b>Answer call:</b> Click the call button</p> <p><b>End call:</b> Click the call button</p> <p><b>Reject call:</b> Press and hold the call button for 2s</p> <p><b>Recall last number:</b> Double-click the call button</p> <p><b>5. Factory reset</b></p> <p><b>Restore factory settings:</b> Under turned on status, press and hold the "1" and "2" buttons simultaneously for 5s</p>	<p><b>Indicator instructions</b></p> <table border="1"> <tr> <td>Turn on</td> <td>The 6-color light ring keeps on</td> </tr> <tr> <td>Turn off</td> <td>The 6-color light ring keeps on</td> </tr> </table> <p><b>Prompt tone instructions</b></p> <table border="1"> <tr> <td>Turn on</td> <td>"doo-doo-doo" sound in rising tone</td> </tr> <tr> <td>Turn off</td> <td>"doo-doo-doo" sound in falling tone</td> </tr> <tr> <td>Connected</td> <td>"doo-dier" sound</td> </tr> <tr> <td>Disconnected</td> <td>"doo-doo-doo" sound in falling tone</td> </tr> <tr> <td>Call reminder</td> <td>Synchronize with the ringtone for iOS system or "doo""doo""doo" sound for Android system that cannot synchronize the ringtone.</td> </tr> </table>	Turn on	The 6-color light ring keeps on	Turn off	The 6-color light ring keeps on	Turn on	"doo-doo-doo" sound in rising tone	Turn off	"doo-doo-doo" sound in falling tone	Connected	"doo-dier" sound	Disconnected	"doo-doo-doo" sound in falling tone	Call reminder	Synchronize with the ringtone for iOS system or "doo""doo""doo" sound for Android system that cannot synchronize the ringtone.	<p><b>FAQ</b></p> <p>Q: Why can't the receiver be connected?          A: ① It may be that the receiver has been connected to another device (such as a computer or mobile phone). Please disconnect it from the device and make a reconnection.          ② Since the IP phone's BT has no automatic refresh function, you can click "JR-CB3" manually on the BT interface.          ③ If above operations failed, you can restore the receiver to factory settings.</p> <p>Q: Why is the sound of the receiver too low?          ① If you are an Android user, it may be that the playback channel of the mobile phone is not turned on. Please turn your phone's BT function on, click the icon on the right side of the connected earphones to turn on the "media channel and call channel".          ② If you are an IP user, please open your phone's "settings" interface, and check if there is a maximum volume limit on the phone.          ③ Due to different operating systems of different phones, the volume of the receiver may not be synchronized with the volume of the phone's car audio. Please manually volume up the mobile phone, the receiver and the car audio respectively.</p> <p>Q: Why can't the receiver be turned on when connected with power?          A: ① The USB charging port and cable may not be connected properly, please pull the cable out and plug it in again repeatedly to make sure it is well inserted.          ② Please use adapters or car chargers that conform to national/regional safety standards to supply power for the product. Adapters with excessive power may be incompatible.          ③ The product does not support PD protocol, when using PD power adapters to supply power for the product, it may be incompatible.</p> <p><b>Safety Criterion</b></p> <ol style="list-style-type: none"> <li>1. Please follow the instructions, do not disassemble the product or refill it for any reason, otherwise it may break down or burn down.</li> <li>2. Do not immerse it in any liquid or wash it with water.</li> <li>3. Please use adapters that conform to national/regional safety standards together with the included charging cable to charge the product, otherwise its battery may be damaged or cause safety problems.</li> <li>4. Please use and store it in normal temperatures, too low or too high temperature (below 0°C or above 40°C) is not permitted.</li> <li>5. Do not block the openings of the product, such as charging port, audio port and microphone, etc.</li> <li>6. Do not use it under thunderstorm which may lead to abnormal performance and signal interruption.</li> </ol>	<p><b>Warranty Card</b></p> <p>User Name: _____          User Tel: _____          User address (with postcode): _____          _____          Purchase date: _____          Invoice No.: _____          Dealer Name: _____          Dealer Address (with postcode): _____          Dealer Tel: _____</p> <p><b>Warranty</b></p> <p>A: If there is performance failure on this product and it's not cause by human error damage, we will provide 12-month free warranty service for consumers from the date of purchase.</p> <p>B: Warranty Exemptions:</p> <ul style="list-style-type: none"> <li>Human damage;</li> <li>Beyond the warranty period;</li> <li>Failure to provide valid purchase certificate;</li> <li>Product damage caused by failure to follow the use, maintain and preserve instructions;</li> <li>Product damage caused by disassemble it or repair the product without authorization, or immerse the product in water;</li> <li>Damage caused by other force majeure.</li> </ul>	<p><b>FCC Statement</b></p> <p>This device complies with part 15 of the FCC Rules. Operation is subject to the following two conditions: (1) This device may not cause harmful interference, and (2) this device must accept any interference received, including interference that may cause undesired operation.</p> <p><b>RF Exposure Information</b></p> <p>Caution: Any changes or modifications to this device not explicitly approved by manufacturer could void your authority to operate this equipment.</p> <p>This equipment has been tested and found to comply with the limits for a Class B digital device, pursuant to part 15 of the FCC Rules. These limits are designed to provide reasonable protection against harmful interference in a residential installation. This equipment generates, uses and can radiate radio frequency energy and, if not installed and used in accordance with the instructions, may cause harmful interference to radio communications. However, there is no guarantee that interference will not occur in a particular installation. If this equipment does cause harmful interference to radio or television reception, which can be determined by turning the equipment off and on, the user is encouraged to try to correct the interference by one or more of the following measures:</p> <ul style="list-style-type: none"> <li>Reorient or relocate the receiving antenna.</li> <li>Increase the separation between the equipment and receiver.</li> <li>Connect the equipment into an outlet on a circuit different from that to which the receiver is connected.</li> <li>Consult the dealer or an experienced radio/TV technician for help.</li> </ul> <p>The device has been evaluated to meet general RF exposure requirement. This equipment should be installed and operated with minimum distance 0mm between the radiator &amp; your body.</p>
Turn on	The 6-color light ring keeps on																	
Turn off	The 6-color light ring keeps on																	
Turn on	"doo-doo-doo" sound in rising tone																	
Turn off	"doo-doo-doo" sound in falling tone																	
Connected	"doo-dier" sound																	
Disconnected	"doo-doo-doo" sound in falling tone																	
Call reminder	Synchronize with the ringtone for iOS system or "doo""doo""doo" sound for Android system that cannot synchronize the ringtone.																	