

Intelligent Vacuum Cleaner (Household) Model: F8S

Instruction Manual

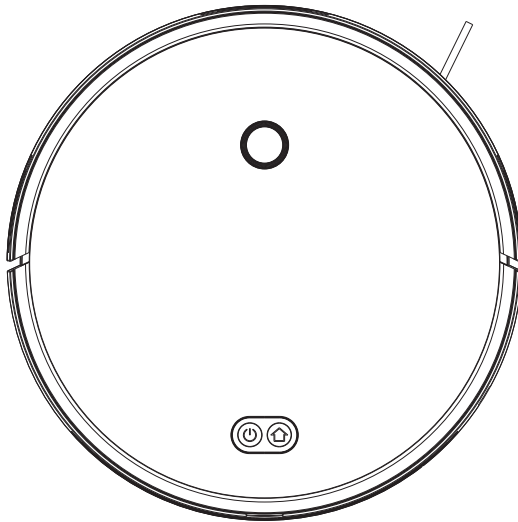

Warranty Card is Included

Thank you for purchasing our Intelligent Vacuum Cleaner.

The shape and color of illustrations in this manual may be different from the purchased product. Please refer to the purchased product.

Please read the manual carefully before charging and using the product, in order for correct operation and extending service life.

Be sure to read [Safety Precautions] carefully, especially before use.

After reading, please properly keep this manual for easy reference at any time.

If you need to transfer the product to a third party, please attach the manual with the product.

CONTENTS

I. Safety Precautions	2
II. Product Components	5
III. Product Usage	8
IV. Product Maintenance	15
V. Specifications	16
VI. Environmental Protection List	17
VII. Warranty Clarification	18
VIII. Warranty Card	19

I. Safety Precautions

1.1 General Safety Regulations



Although this product can be used by children over 8 years old and by persons with impaired physical, sensory or mental function, or without relevant experience or knowledge, they need to use this product in a safe manner under supervision or guidance and be aware of the possible risks. Children are not allowed to play with this product. Children should not clean and maintain this product without supervision.

Warning: Do not touch the robot's electronics, battery or charging base. Users are not allowed to maintain internal components of the product.

Product maintenance requires authorized professional maintenance personnel to operate. Please make sure that the nominal voltage of the power supply of the charging base is in accordance with the standard socket voltage.

1.2 Safety Instruction

- Please read all safety precautions and instructions before operating this robot.
- Please pay attention to all warnings on battery, power adapter, robot and instruction manual.
- Please follow all instructions described in this manual.
- All non-routine maintenance shall be the responsibility of Fushida's professional staff.
- The harm and the degree of damage caused by the wrong operation are explained as follows.

 Warning	Indicates a potentially hazardous condition that, if not avoided, may result in death or serious injury.
 Attention	Indicates a potentially hazardous condition that, if not avoided, may result in mild or moderate injury.

1.3 Safety Precautions Regarding to the Product

⚠ Warning

This product is limited to use the original battery charging base and adapter, otherwise it may lead to fire caused by product damage, electric shock or high pressure. Before use, please put the charging base beside the wall and do not place anything within 2 meters or about 1 meters in front of it.

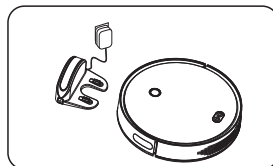

If the host machine and accessories of the product are found to be damaged, please do not use external components of the product to replace. Please contact the after-sales service department of our Company. Except for the maintenance personnel designated or authorized by our company, others are forbidden to disassemble, repair or modify the product.

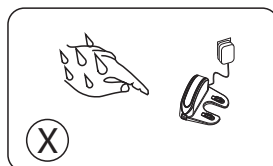

Do not use in the dangling environment without protective fences, so as to avoid accidental fall of the vacuum cleaner, causing personal injury.

Do not use the power cord to drag or move the product. Do not excessively twist and bend the power cord, or place heavy objects on the machine.

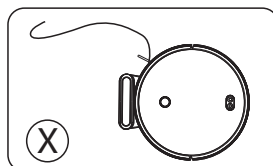

Do not use in the dangling environment without protective fences, so as to avoid accidental fall of the vacuum cleaner, causing personal injury.

Do not use the power cord to drag or move the product. Do not excessively twist and bend the power cord, or place heavy objects on the machine.

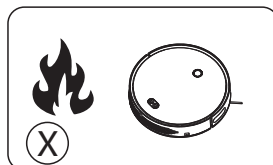

⚠ Attention

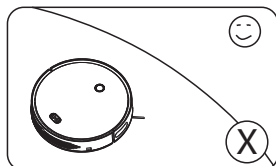

This product is for indoor use only.

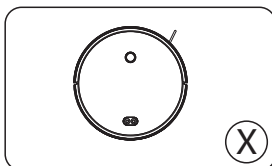

Preventing the vacuum cleaner from being damaged by water, oil or other liquids.

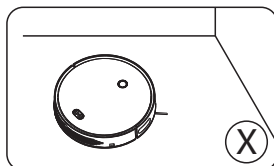

Tiding up the scattered wires on the floor before using to avoid interfering with the vacuum cleaner.

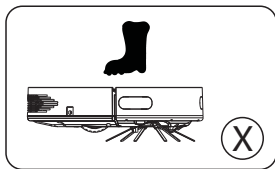

Heavy objects are forbidden to place on the machine and children are not allowed to stand on it, which may damage the internal components.

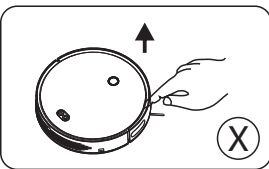

Movable safety fence of the front part of the machine is forbidden to lift alone, which may damage the front shell of the machine and cause function failure.

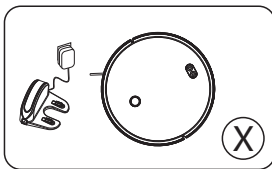

Before use, please pay attention to the scattered wires on the ground, such as plug power cord, telephone line, so as not to interfere the sweeper to work.

1.4 Regarding to Children Safety

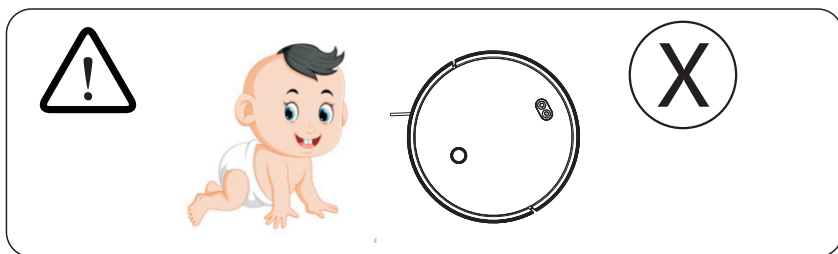

Children are not allowed to use this product alone.

Children are not allowed to play with the package of products, which may cause suffocation.

1.5 Regarding to Battery



1. This product is only available with batteries provided by the manufacturer;
2. The battery must be taken out when the product is discarded;
3. If you need to replace the main battery, please contact our after-sales service department; if the wrong type of battery is used to replace, it may cause safety accidents.
4. In case of battery leakage and the liquid sticks to the skin or clothes by accident, wipe the battery immediately with a dry cloth and send the discarded battery to the recycling station or designated maintenance point. Do not discard the battery carelessly.

II. Product Components

2.1 Packing List

Serial No.	Description	No.
1	Host Machine	1
2	Charging Base	1
3	Power Adapter	1
4	Instruction Manual	1
5	High Efficiency Particulate Air Filters	2
6	Side Brushes	2
7	Water Tank	1
8	Remote Control	1
9	Mops	2
10	Cleaning Brush	1

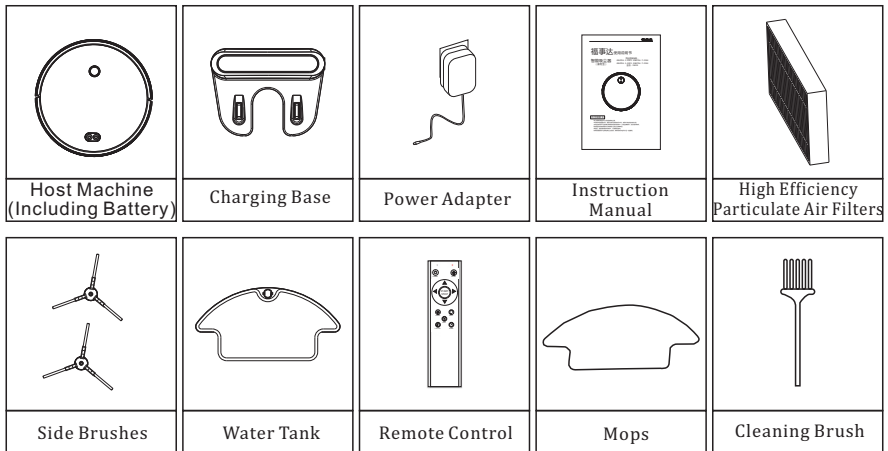

★ Tips:

*If the machine does not need to be used for a long time, please fully charge at least once every 30 days.

2.2 Product View

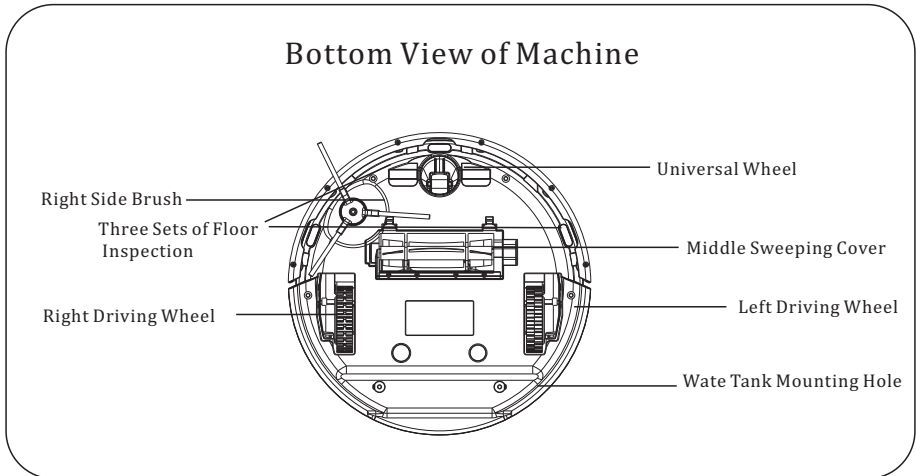
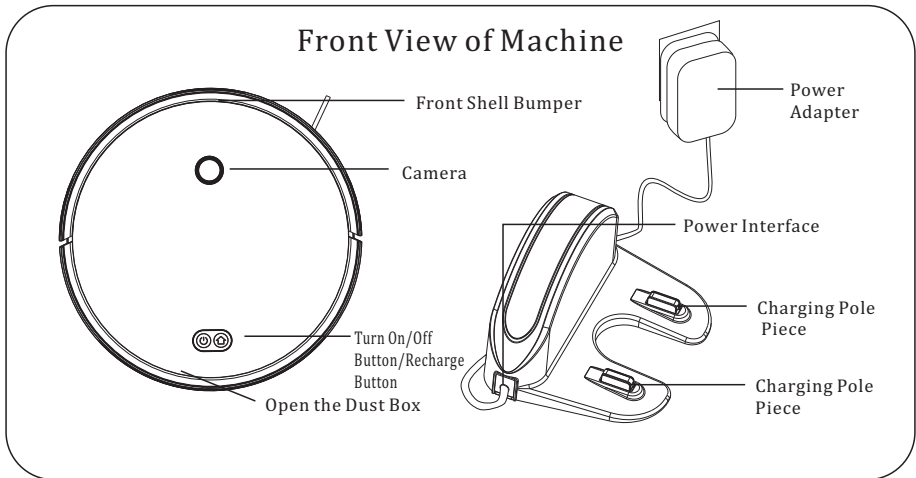

Dust Box Internal Structure

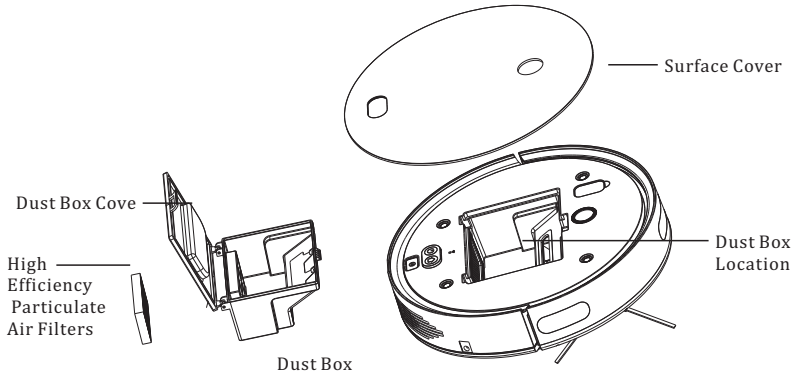

2.3 Dust Box and Water Tank Installation

- **Taking Out Dust Box:** Hold the handle by hand and pull it vigorously; Putting In Dust Box: Put in the dust box and flatten.
- **Mop Installation:** After water is injected into the water tank, press the sealed rubber cover tightly. Insert the mop cloth into the front end of the water tank, flatten the mop and paste to the water tank, do not crumple up.
- **Water Tank Installation:** Overturn the machine and flatten, align two columns of the water tank to two empty holes on the machine, press in the water tank evenly with hands at the same time. Taking Out Water Tank: Pull out evenly with both hands.

Dust Box Installation

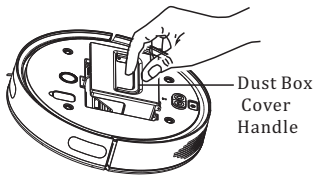

Add Water

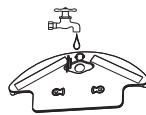

Install the mop

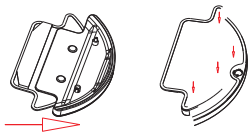

Install the water tank to the host machine

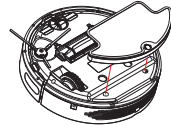

2.4 Cleaning Side Brushes

- Cleaning rubbishes on side brushes with a cleaning brush. If the hair is entangled on the side brush, drag the hair bundle with both hands and pull out the side brush fiercely. Carefully cut the twined hair with scissors, clean it and reinstall.

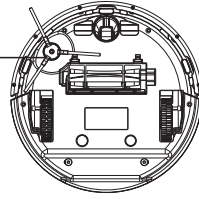
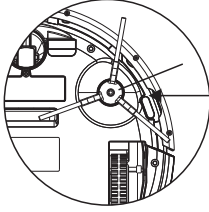

1. **Installation Steps:** Align the side brush with the hole position of side brush on the base (please pay attention to the flat position and round), press and hear the sound of "snap", indicating that the side brush installation is in place.
2. **Disassembly Steps:** Drag two hair bundles at both sides with both hands and pull them out with a little force.

★ **Tips:**

Before use every time, please check whether the side brush has been assembled properly, otherwise it will affect the cleaning effect of the vacuum cleaner.

III. Product Usage

* **Note:** Before cleaning, please remove the protective pieces on both sides of the front shell of the machine, and then sort out small objects or obstacles in the room, especially the tangled objects like electric wires.

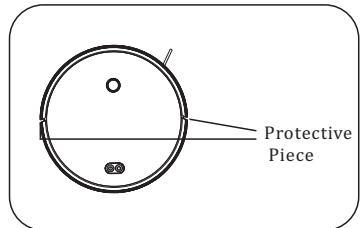

3.1 The Use Scope of the Product

The Use Scope The product is suitable for the following ground environment



Wood Floor



Shorthair Carpet

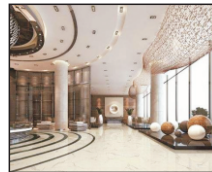

Ceramic Tile

Inapplicability Scope

- * Not suitable for use in extremely hot (above +45°C) or extremely cold (below -5°C) environments.* This product is for indoor use only.
- * Do not use in the dangling environment without protective pieces, to avoid accidental falling of the product and causing personal injury.
- * Do not use in a damp or flammable, explosive or corrosive environment.
- * Do not use for sucking up burning cigarette ends or matches etc.
- * Do not use for sucking up color matching agent and toner used inside laser printers and copying machines, which may cause fire.
- * Do not use for sucking up sharp objects, such as glass, nails, etc., which may cause damage to the product.

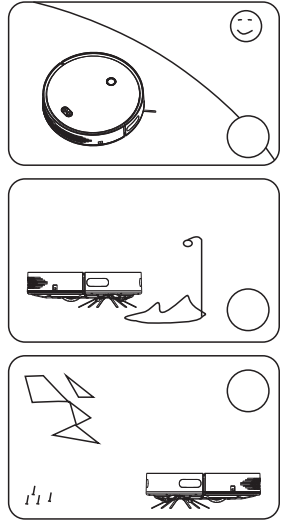

3.2 Machine Working Condition

1. Description of Function Keys

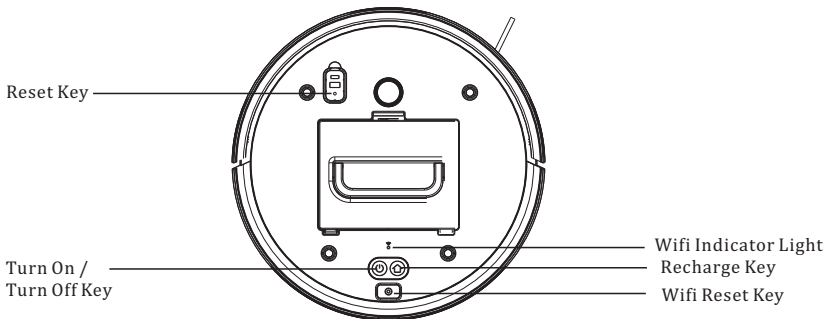

1. Key, Turn On / Turn Off Key, after power on, press the key again for auto cleaning and pause.
2. Key, Automatic Recharge Key, in any mode after power on, press the key and the machine will recharge automatically.
3. Wifi Reset Key, when it is necessary to set the connection between the machine and wifi network, please press the key for a long time, loose hand when the wifi indicator light of the machine quickly flashes, indicating that the machine begins to reconnect with wifi network.
4. Reset Key, when the machine cannot be turn on or off due to unexpected circumstances and abnormal running occurs, you can stab the switch with a sharp needle or screwdriver and the machine will shut down automatically.

2. Machine Indicator Light State

No.	Working State	Indicator Light Display	Voice Broadcast
1	Starting up	Blue light flicks	System is starting, please wait a moment
2	Turn on complete and standby	Blue light bright all the time	Power on music
3	Sweeping	Blue light bright all the time	Sweep automatically
4	Recharging Low Battery	Red light flicks	Return to charge
5	Charging	Blue light breath state flicks	Start to charge
6	Fully Charged	Blue light bright all the time	Charging completed
7	Fault Time	Red light bright all the time	***
8	Connecting to network	Wifi blue light flicks	Please wait for the result in APP
9	Sleeping	Indicator Light extinguish	/

3. Connection Operation Between Mobile Phone WiFi and Machine

- 3.1 Connect the mobile phone to the wifi network in the family environment;
- 3.2 Download the "Tuya Smart" APP on mobile phone, search for "Tuya Smart" from the mobile phone application market, download and install;
- 3.3 APP account register with mobile phone number, receive and fill in the verification code at the same time, set the login password, successful registered;
- 3.4 Click "Add Device" in the APP, then "Small Appliances", and select "Sweeper Robot".

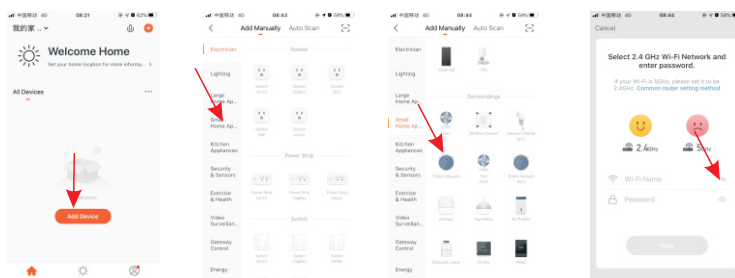



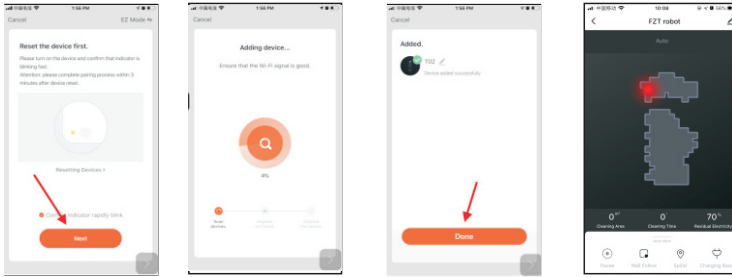

- 3.5 Select the network required to connect to the family, as shown in figure 4 on the right, click the "☰" pull-down list to select the network name required to connect, then enter the wifi password, and click next;

3.6 Reset the wifi of the machine, long press the wifi reset key on the machine, loose when hearing the voice "Network Matching", the blue light of the wifi quickly flashes; then click "Indicator light Flashing" on the APP interface, and then click next;

3.7 While waiting for wifi connection, once wifi connection is successful, click the sweeper icon and enter the main interface of APP to operate.



4. Remote Control Status (Optional)

1. Press the Suction Adjustment Key of “” to adjust the suction of the machine fan.
2. Press the Edgewise Sweep Key of “” to enter the edge cleaning mode.
3. Press the Fixed Point Cleaning Key of “” to start the area cleaning in spiral way with the current point as the center.
4. Press the Full Charged Cleaning Key of “”, when the machine is on the charging base, press this key to enter the full charged cleaning mode. When the machine is fully charged, it will automatically exit from the charging base and start to clean automatically. When the battery is low again, it will automatically return to the charging base. After fully charged, it will go out to clean again, when the second cleaning is completed, it will automatically exit from this mode. If the machine leaves the charging base midway, it will exit from the full charged cleaning mode.
5. Press the “” key to find the machine. Press this key and the machine will announce "I'm here" to remind the user.

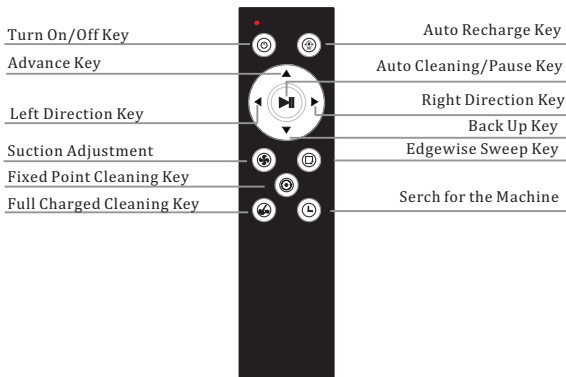

5. Automatic Cleaning

Automatic Cleaning Mode is suitable for cleaning the whole house. In the automatic cleaning state, the blue light of the machine flashes.

1. After the machine starts, firstly scan and identify the environment, establish the cleaning area and plan the cleaning path;
2. Then, according to the planning area, use the arched path for cleaning, and automatically avoid obstacles and steps, etc.;
3. Set up the cleaning path map in real time to clean with planned path, to ensure that all areas can be cleaned;
4. After the cleaning of each area is completed, the machine will automatically return to the charging base to charge, according to the path.



Automatic Cleaning Mode Cleaning Path

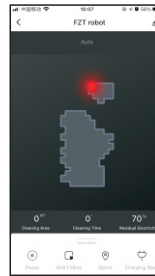

6. APP Operation and Use

Description of main interface function keys:

- **Auto:** Auto Cleaning Key, after starting up, the machine will give a voice prompt of "Automatic Cleaning" in place, which is similar to the function of the host machine turn on/off key and the AUTO key of remote control;
- **Edgewise:** Edgewise Sweep Key, the machine will give a voice prompt of "Edgewise Sweeping", after the machine cleaning along the edge for a week, there will be voice prompt "Cleaning Completion";
- **Fixed Point:** Fixed Point Cleaning Key, voice prompt "Fixed Point Cleaning", the machine starts to do spiral expanding circular cleaning at the original point, and returns to the origin point after expanding to a range of 1m in diameter;
- **Recharge:** Auto Recharge Key, similar to the recharge key of the host machine and the HOME key of the remote control;
- **Map:** Machine cleaning map can be checked;
- **Find the machine:** Click the key, the machine will automatically announce "I'm here" to remind;

Click "More" to open the interface as shown in the right picture:

- **Consumables:** Record and evaluate the use of middle brush, side brush and filter screen;
- **Sweeping Record:** Record the recent machine use record;
- **Timing:** Scheduled cleaning function, can set at any time of 24 hours a day, 7 days a week, and can set repeatedly;
- **Suction Selection:** Adjust the suction gear of fan, to increase the effect of cleaning and vacuuming, but the suction gear is proportional to the machine noise, need to adjust as needed;
- **Water Yield Adjustment:** Adjust the speed of water leakage in the water tank, which is not applicable to this machine at present;
- **Breakpoint Continuous Sweep:** If the machine has not finished cleaning, the battery has no power, the machine will be automatically recharged, after fully charged, and then continue to clean previously unfinished tasks;
- **Static Switch:** Turn off the machine voice broadcast function.

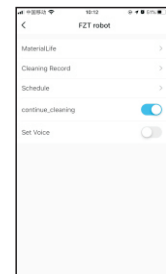
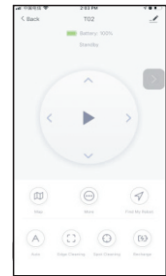

7. Charging Operation

7.1 Charging Base Placement

In order for the machine to find the charger timely, it is recommended to place the charging base smoothly on the hard wall, and do not place objects within a range of 2 meters in front and 1 meter on the left and right, so as not to block the signal of the recharging base and cause the machine to fail to recharge normally.

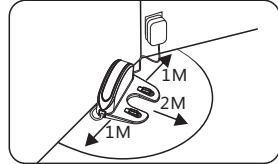

7.2 Automatic Charging

Starting Method: Press the machine/remote control /APP recharge key, and the voice prompts "Return to Charge". The machine will enter the automatic charging mode.

1. When the electric quantity of the machine is within the range of 1%-10%, the machine will voice prompt "low electric quantity" for any operation except the recharge key;
2. When the electric quantity of the machine $\leq 10\%$, the machine will automatically voice prompt "low electric quantity";
3. The machine will automatically voice prompt "Start Charging" after successfully connecting to the recharging base.

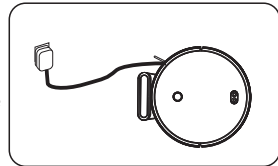

7.3 Manual Charging

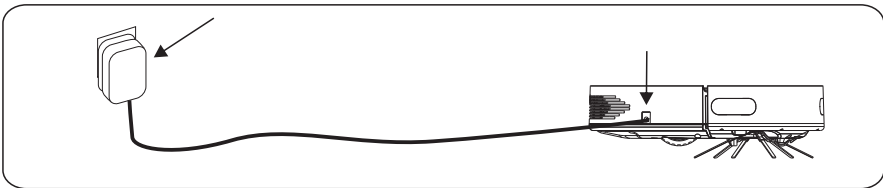

Plug the power adapter directly into the mains socket, and plug the DC plug on the other side directly into the machine. The machine will report "Start Charging" and the blue light will flash.

1. Please fully charge the machine for 12 hours when charging for the first time.
2. During daily use, please store the machine on the charging base and ensure the charging base is connected to the power.
3. If you do not use the machine for a long time, please fully charge the machine, turn off and store in a ventilated and dry place.

8. Common Problems and Solutions

Problem Types	Reasons and Solutions
Report wheel, middle brush, side brush stuck/trap	During the cleaning process of the machine, left and right wheels, middle brush and right brush get stuck/trap by the foreign matter. The voice reminds "Please clean ***".
The dust box is missing/not in place	When the machine starts to work, if the dust box is missing/not in place, the voice reminds "Please install the dust box";
Off the hook	In the process of cleaning, when the machine is entangled by wire/curtain/carpet and cannot get free, the voice reminds "Please help me to get off the hook".
The machine is against the wall	Whether the protective pieces on both sides of the front shell are removed; If there is foreign matters or collision damage involved in the front shell bumper, touch the front shell with hand, the front shell should be able to be pressed down and bounce up, in order to clean up the foreign matter inside.
Unable to turn on	If the battery is low, please insert the adapter directly into the machine, and the machine will turn on automatically. If the environment temperature is too low (below -5° C or above +50°C), please use it at the indoor temperature.
Unable to charge	Please check whether the indicator light above the recharging base is on and confirm that the charging adapter has been inserted into the AC mains to ensure normal power supply. If the contact is not good, please clean if the charging base contact shrapnel and the charging pole piece of the host machine is dirty, or remove the side brush (to block the contact).
Unable to recharge	There are too many obstacles attached to the charging base. Please move the charging base to an open area; In the process of cleaning, if the recharging base or machine is moved manually, the map will be abnormal and the position of the recharging base will be lost.
Abnormal behavior	Open the face cover and stab the reset key switch directly.
There is a weird noise when cleaning	The middle brush, side brush and wheel may be entangled with foreign matter. Please clean up after stopping the machine.
Reduced sweeping ability or dust drop	The dust box is full, please clean the dust box. The filter is blocked, please clean or replace the filter; the middle brush is twined with foreign matters, please clean the middle brush.
Unable to connect wifi	Wifi signal is not good, please make sure that the machine is in a good wifi signal coverage area; if the wifi connection is abnormal, please reset the wifi router, download the latest APP client version, and try to connect again;Wifi password input error; Wifi router is 5G frequency band, and this machine only supports 2.4G frequency band at present.
Schedules cleaning does not work	When it comes to the scheduled cleaning time, if the electric quantity of the machine is not sufficient, it will be cleaned automatically only when the electric quantity is more than 10%.
Whether the power consumed if machine has been running on the recharging base	The machine always consumes very little power when recharging on the recharge base, which is helpful to keep the battery in the best performance; unable to turn off on the recharge base.

IV. Product Maintenance

4.1 Side Brushes Cleaning

When the side brush becomes dirty, please wash the side brush with water. If the side brush has been damaged, it can be replaced.

4.2 Dust Box and Filter Screen Cleaning

After use every time, please timely clear and clean the dust box, filter screen. The specific operation is shown in the following figure:

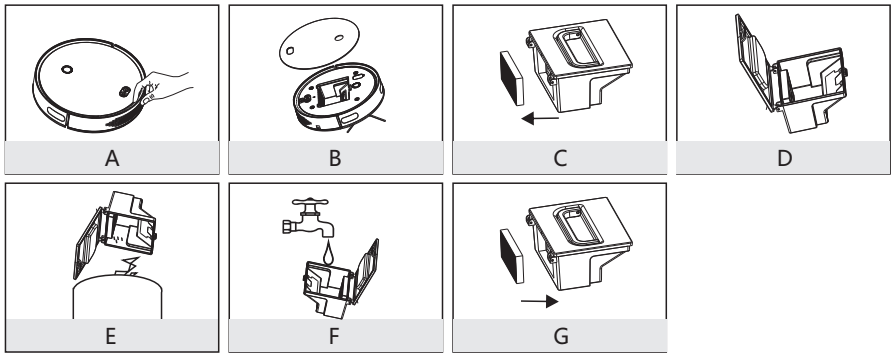

★ Tips:

After taking out the dust box, please check whether there is any foreign matter in the suction inlet and clean.

The filter screen can be flapped to remove dust. If it is wet out by the water, please be sure to dry before installing.

4.3 Sensor and Charging Dock Electrode Slice Cleaning

Gently wipe the sensors and electrode slices on the bottom of the machine with a cleaning tool or a soft cloth.

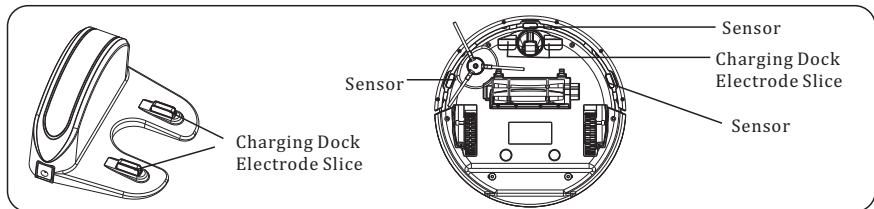

★ Tips:

If there is any foreign matter on the Dock Electrode Slice of charging base, it should be cleaned in time..

V. Specifications

Model	F8S
Operating Voltage	14.8V
Rated Power	30W
Rechargeable Battery	Lithium Ion Battery
Battery Capacity	2600mAh
Charging Time	About 3-4 hours
Working Hours	≥60 minutes
Operating Temperature Range	-5°C-45°C
Work Degree of Humidity Scope	≤90% RH
Dust Box Capacity	430mL
Noise	≤65dB
Size (Diameter X Height)	Φ 315X81mm

★ Tips:

Due to the continuous improvement of the product, the company reserves the right to make any technical or design changes to the product. The company reserves the right of interpretation.

VI. Environmental Protection

In accordance with Regulations of the Restricted Use of Hazardous Substances in Electrical and Electronic Products of the People's Republic of China, the name and content of toxic substances or elements that may be contained in electrical and electronic products are listed in the following table:



Name of parts	Toxic and Hazardous Substance or Element					
	Lead (Pb)	Mercury (Hg)	Cadmium (Cd)	Chromium VI (Cr (VI))	Polybrominated biphenyls (PBB)	Polybrominated diphenyl ethers (PBDE)
Plastic Parts	0	0	0	0	0	0
Electronics & Electrical Appliances	X	0	X	X	0	0
Rubber Sponge	0	0	0	0	0	0
Hardware	X	0	0	0	0	0
Packing material	0	0	0	0	0	0

This table is prepared in accordance with GB/T26125-2011/IEC62321:2008.

○: To indicate that the content of the toxic and hazardous substance in all homogeneous materials of the part are below the limit specified in GB/T26125-2011/IEC62321 :2008.

X: To indicate that the content of the toxic and hazardous substance in at least one homogeneous material of the part exceeds the limit specified in GB/T26125-2011/IEC62321:2008.



Circular Arrow Mark: To indicate that this product is recyclable. If the product fails to operate properly after the maintenance or its service life is expired, it should not be discarded at will. Please send it to the formal recycling center and the enterprises with used electrical and electronic products disposal qualification. Regarding the correct disposal method, please refer to the national or local disposal regulations on used electrical and electronic products.

Description of Hazardous Substances: The content of hazardous substances or elements in materials used in our products has complied with the limit requirements of the hazardous substance standard in GB/T26125-2011/IEC62321:2008. The parts marked MXW indicate that the replacement of the content of hazardous substance or element cannot be realized due to the development of global technology level. Our company will make efforts to replace harmful substances according to the development of global technology. If the hazardous substances in materials are upgraded thanks to the development of technology and environmental protection, it will be included in the new version of the instruction manual.

VII. Warranty Instruction

According to the "New Three Guarantees", the warranty period of the complete machine is ONE YEAR "from the date of purchase". (The warranty is available for home use only).

1. In the warranty period, as long as the fault caused by the quality of the product itself, customers can bring the completed *Product Warranty Card* and Purchase Invoice to the "Special Maintenance Center" around the country for free repair.
2. Please keep the purchase invoice and warranty card properly as the warranty certificate. Once the invoice is altered, the warranty will become invalid.
3. If the warranty period has expired, customers can contact the customer service department of the company for mail order of spare parts, or purchase from the local retailer.
4. Special customer service center have the obligation to provide superior service to customers. If customers have any objection to their service quality, customers can directly complain to our customer service department.
5. If the warranty period is promised in the instruction manual, the instruction manual shall prevail.

No maintenance will be free under the following circumstances:

1. No warranty card and valid purchase invoice.
2. The complete machine and parts have exceeded the free warranty period.
3. The model in the warranty card does not conform to the model of product for maintenance or the warranty card is altered.
4. Fault or damage caused by failure to operate the machine as specified in the instruction manual.
5. Damage caused by improper use, storage and maintenance of consumers.
6. Damage caused by disassembly of other maintenance personnel (i.e. not authorized by our company).
7. Fault or damage caused by accidental factors or human reasons (including operation error, liquid inlet, improper plugging, scratch, transport, collision, improper voltage input, etc.).
8. Damage caused by force majeure (such as earthquake, fire disaster, lightning stroke, etc.).
9. Normal and reasonable consumption or damage (such as natural consumption, wear and aging of the shell and connector parts).
10. Other faults and damages not caused by quality problems of our products (including parts).

Note:

The customer service department of our company will still serve you warmly if the product is not within the warranty scope.

FCC Statement

This device complies with part 15 of the FCC Rules. Operation is subject to the following two conditions:

(1) This device may not cause harmful interference, and (2) this device must accept any interference received, including interference that may cause undesired operation.

-Reorient or relocate the receiving antenna.

-Increase the separation between the equipment and receiver.

-Connect the equipment into an outlet on a circuit different from that to which the receiver is connected.

-Consult the dealer or an experienced radio/TV technician for help.

Any Changes or modifications not expressly approved by the party responsible for compliance could void the user's authority to operate the equipment.

Note: This equipment has been tested and found to comply with the limits for a Class B digital device, pursuant to part 15 of the FCC Rules. These limits are designed to provide reasonable protection against harmful interference in a residential installation. This equipment generates uses and can radiate radio frequency energy and, if not installed and used in accordance with the instructions, may cause harmful interference to radio communications. However, there is no guarantee that interference will not occur in a particular installation. If this equipment does cause harmful interference to radio or television reception, which can be determined by turning the equipment off and on, the user is encouraged to try to correct the interference by one or more of the following measures:

This equipment complies with FCC radiation exposure limits set forth for an uncontrolled environment.

This equipment should be installed and operated with minimum distance 20cm etween the radiator & your body.