

DWG revision relationship			
Customer:	CUST00171	CUST P/N:	434-00398
		BYD P/N:	14352230-00
CUST DWG REV	BYD DWG REV	Change description	Date
A	A0	初版图纸绘制	03'02/2023

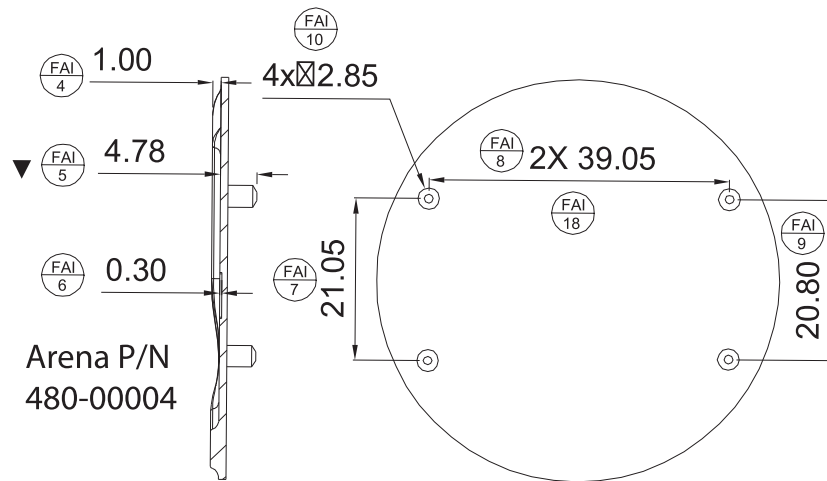

★秘密★

文件名称	硅胶垫_ECS2204-A00_白色_成型_底座硅胶垫_RoHS_技术标准SAP:14352230-00			文件编号	
文件层级	三级文件	版本号	A0	页次	1/1

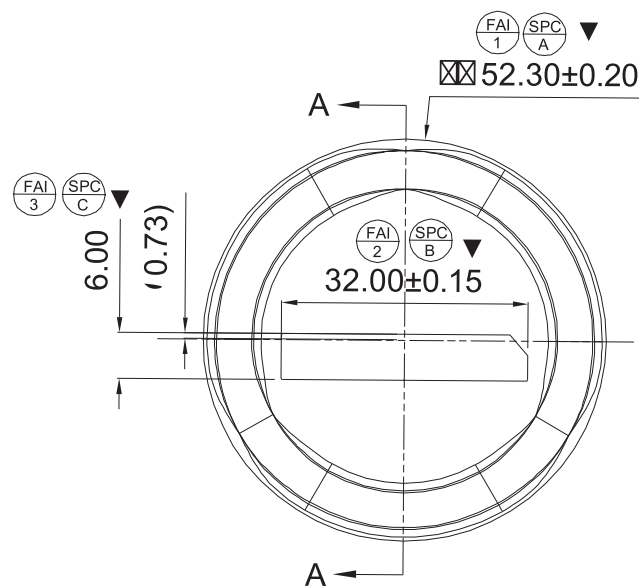

SECTION A-A

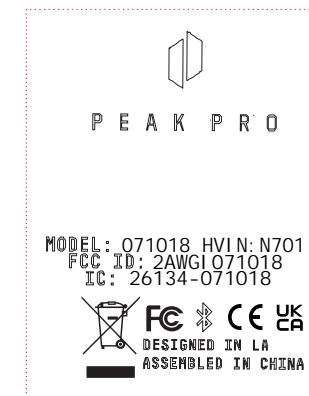
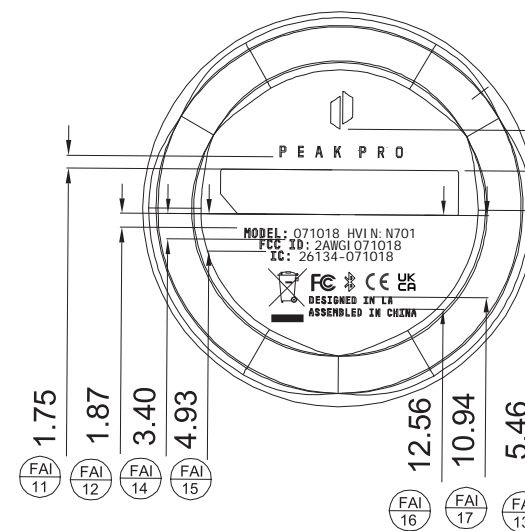

丝印颜色 : Cool Grey 8C printing

NOTES

- MATERIAL: SILICONE GA-1073+3270. COLOR: White, 50% transparency + Cool Grey 8C printing. HARDNESS: 70A
- FINISH: MT-11000.
- ALL REFERENCE 3D NOT MARKED.
- PART SURFACE BURR ≤ 0.05 .
- THE PRINTED TEXT IS CLEARLY VISIBLE.
- DIMENSION MARKED "▼" TO BE CHECKED BY QC.
- THE PART MUST COMPLY WITH REGULATED SUBSTANCE REQUIREMENTS: EUROPEAN RoHS 3.0 DIRECTIVE & REACH CP 65 TEC
- TOLERANCES DESIGNATED WITH THE SYMBOL (SPC) SHALL BE PRODUCED WITH STATISTICAL TOLERANCE PROCESS CONTROLS. IN ORDER TO USE THE TOLERANCE ON A FEATURE, THE STATISTICAL PROCESS (CP, CPK, ETC)

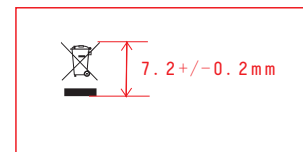

技术要求:

- 材料: 硅胶 GA-1073+3270 颜色: 白色, 50%透明度+Cool Grey 8C printing
- 表面处理: MT-11000, 硬度 $70 \pm 5A$;
- 未注尺寸参考3D;
- 产品表面毛边 0.05 ;
- 带标志 "▼" 需由QC管控检查来料;
- 环保要求: 产品须满足欧盟RoHS 3.0、REACH和CP 65等;
- 使用符号指定的公差 (SPC) 控制生产 (使用统计过程CP, CPK进行特征公差控制), 未特殊说明公差标准以C列公差带为准。

功能性特征:

- △ 需要通过 IQC/IPQC 进行出货检验;
- ▼ 需要过程能力研究要求 $CPK > 1.00$;
- ◇ 需要进行的统计过程控制 PPK: \ ;

TOLERANCE UNLESS OTHERWISE SPECIFIED (+/-)							
CLASS	A	B	©	D	E	F	G
<8mm	0.05	0.1	0.1	0.2	0.2	0.4	0.4
8~25mm	0.08	0.15	0.15	0.3	0.3	0.6	0.6
25~80mm	0.12	0.2	0.25	0.4	0.5	0.8	1.0
80~250mm	0.25	0.3	0.4	0.6	0.8	1.2	1.5
250mm~800mm	0.5	0.6	0.8	1.0	1.5	2.0	3.0
>800mm	1.0	1.0	1.5	1.7	3.0	4.0	6.0
ANGLE	0.5						

设计: 刘建树 审核: 杨家顺 批准: 赵冬生