

## Trademarks

iCarsoft, CR Max and CR MAX BT are trademarks of iCarsoft Intelligent Technology Corp., Ltd., registered in the United States and other countries. All other marks are trademarks or registered trademarks of their respective holders.

## Copyright Information

No part of this manual may be reproduced, stored in a retrieval system or transmitted, in any form or by any means, electronic, mechanical, photocopying, recording, or otherwise without the prior written permission of iCarsoft.

## Disclaimer of Warranties and Limitation of Liabilities

All information, specifications and illustrations in this manual are based on the latest information available at the time of printing.

iCarsoft reserves the right to make changes at any time without notice. While information of this manual has been carefully checked for accuracy, no guarantee is given for the completeness and correctness of the contents, including but not limited to the product specifications, functions, and illustrations.

iCarsoft will not be liable for any direct, special, incidental, indirect damages or any economic consequential damages (including the loss of profits).

---

### **!** IMPORTANT

Before operating or maintaining this unit, please read this manual carefully, paying extra attention to the safety warnings and precautions.

---

## For Services and Support



[Http://www.icarsoft.us](http://www.icarsoft.us)  
[Http://www.icarsoft.com](http://www.icarsoft.com)  
[Support@icarsoft.us](mailto:Support@icarsoft.us)



For technical assistance in all other markets, please contact your local selling agent.

## Safety Information

---

For your own safety and the safety of others, and to prevent damage to the device and vehicles upon which it is used, it is important that the safety instructions presented throughout this manual be read and understood by all persons operating or coming into contact with the device.

There are various procedures, techniques, tools, and parts for servicing vehicles, as well as in the skill of the person doing the work. Because of the vast number of test applications and variations in the products that can be tested with this equipment, we cannot possibly anticipate or provide advice or safety messages to cover every circumstance. It is the automotive technician's responsibility to be knowledgeable of the system being tested. It is crucial to use proper service methods and test procedures. It is essential to perform tests in an appropriate and acceptable manner that does not endanger your safety, the safety of others in the work area, the device being used, or the vehicle being tested.

Before using the device, always refer to and follow the safety messages and applicable test procedures provided by the manufacturer of the vehicle or equipment being tested. Use the device only as described in this manual. Read, understand, and follow all safety messages and instructions in this manual.

## Safety Messages

---

Safety messages are provided to help prevent personal injury and equipment damage. All safety messages are introduced by a signal word indicating the hazard level.

---

### **DANGER**

Indicates an imminently hazardous situation which, if not avoided, will result in death or serious injury to the operator or to bystanders.

---

### **WARNING**

Indicates a potentially hazardous situation which, if not avoided, could result in death or serious injury to the operator or to bystanders.

---

## **Safety Instructions**

---

The safety messages herein cover situations iCarsoft is aware of. iCarsoft cannot know, evaluate or advise you as to all of the possible hazards. You must be certain that any condition or service procedure encountered does not jeopardize your personal safety.

### **DANGER**

When an engine is operating, keep the service area **WELL VENTILATED** or attach a building exhaust removal system to the engine exhaust system. Engines produce carbon monoxide, an odorless, poisonous gas that causes slower reaction time and can lead to serious personal injury or loss of life.

### **SAFETY WARNINGS**

- Always perform automotive testing in a safe environment.
- Wear safety eye protection that meets ANSI standards.
- Keep clothing, hair, hands, tools, test equipment, etc. away from all moving or hot engine parts.
- Operate the vehicle in a well ventilated work area, for exhaust gases are poisonous.
- Put the transmission in **PARK** (for automatic transmission) or **NEUTRAL** (for manual transmission) and make sure the parking brake is engaged.
- Put blocks in front of the drive wheels and never leave the vehicle unattended while testing.
- Be extra cautious when working around the ignition coil, distributor cap, ignition wires and spark plugs. These components create hazardous voltages when the engine is running.

- Keep a fire extinguisher suitable for gasoline, chemical, and electrical fires nearby.
- Do not connect or disconnect any test equipment while the ignition is on or the engine is running.
- Keep the test equipment dry, clean, free from oil, water or grease. Use a mild detergent on a clean cloth to clean the outside of the equipment as necessary.
- Do not drive the vehicle and operate the test equipment at the same time. Any distraction may cause an accident.
- Refer to the service manual for the vehicle being serviced and adhere to all diagnostic procedures and precautions. Failure to do so may result in personal injury or damage to the test equipment.
- To avoid damaging the test equipment or generating false data, make sure the vehicle battery is fully charged and the connection to the vehicle DLC is clean and secure.
- Do not place the test equipment on the distributor of the vehicle. Strong elector-magnetic interference can damage the equipment.

# CONTENTS

<b>1</b>	<b>USING THIS MANUAL</b>	<b>1</b>
1.1	CONVENTIONS	1
1.1.1	<i>Bold Text</i>	1
1.1.2	<i>Notes and Important Messages</i>	1
1.1.3	<i>Hyperlink</i>	2
1.1.4	<i>Illustrations</i>	2
<b>2</b>	<b>GENERAL INTRODUCTION</b>	<b>3</b>
2.1	CR MAX DISPLAY TABLET	3
2.1.1	<i>Functional Description</i>	3
2.1.2	<i>Power Sources</i>	4
2.1.3	<i>Technical Specifications</i>	5
2.2	ACCESSORY KIT	7
2.2.1	<i>Main Cable</i>	7
2.2.2	<i>Other Accessories</i>	7
<b>3</b>	<b>GETTING STARTED</b>	<b>8</b>
3.1	POWERING UP	8
3.1.1	<i>Application Buttons</i>	9
3.1.2	<i>Locator and Navigation Buttons</i>	10
3.2	POWERING DOWN	11
3.2.1	<i>Reboot System</i>	12
<b>4</b>	<b>DIAGNOSTICS</b>	<b>13</b>
4.1	GETTING STARTED	13
4.1.1	<i>Vehicle Menu Layout</i>	13
4.2	VEHICLE IDENTIFICATION	14
4.2.1	<i>Auto VIN Scan</i>	15
4.2.2	<i>Manual VIN Input</i>	16
4.2.3	<i>Smart Scan</i>	17
4.2.4	<i>Manual Selection</i>	18
4.3	NAVIGATION	19
4.3.1	<i>Diagnostics Screen Layout</i>	19
4.3.2	<i>Screen Messages</i>	20

4.3.3	<b>Making Selections</b> .....	20
4.4	<b>DIAGNOSIS</b> .....	21
4.4.1	<b>Smart Scan</b> .....	21
4.4.2	<b>Manual</b> .....	23
4.5	<b>GENERIC OBD II OPERATIONS</b> .....	29
4.5.1	<b>General Procedure</b> .....	29
4.5.2	<b>Function Descriptions</b> .....	31
4.6	<b>EXITING DIAGNOSTICS</b> .....	33
<b>5</b>	<b>SERVICE OPERATIONS</b> .....	<b>34</b>
5.1	<b>BRAKE BLEED</b> .....	35
5.2	<b>OIL RESET SERVICE</b> .....	37
5.3	<b>ELECTRONIC PARKING BRAKE (EPB) SERVICE</b> .....	40
5.3.1	<b>EPB Safety</b> .....	41
5.3.2	<b>EMF Star-up</b> .....	42
5.4	<b>ELECTRONIC THROTTLE CONTROL</b> .....	44
5.5	<b>INJECTOR</b> .....	46
5.6	<b>STEERING ANGLE SENSOR (SAS) SERVICE</b> .....	48
5.6.1	<b>Steering Angle Sensor Calibration</b> .....	50
5.7	<b>BMS</b> .....	51
5.7.1	<b>Register Battery Replacement</b> .....	52
5.8	<b>DPF SERVICE</b> .....	57
5.8.1	<b>Starting Basic Inspection Quantity</b> .....	58
5.8.2	<b>Injection Rate</b> .....	60
5.8.3	<b>Injector Rate Adjustment</b> .....	62
5.8.4	<b>Particle Filter Regeneration</b> .....	62
5.8.5	<b>Particle Filter Test</b> .....	64
5.9	<b>AFS HEAD LAMP</b> .....	65
5.10	<b>AIR SUSPENSION</b> .....	68
5.11	<b>TPMS PROGRAMMING SERVICE</b> .....	70
5.12	<b>GEARBOX RESET</b> .....	72
5.13	<b>AIR CONDITIONING SERVICE</b> .....	74
5.14	<b>AIR FILTER SELF-LEARNING PROCESS AFTER REPLACING THE AIR FILTER</b> .....	75
5.15	<b>FUEL PUMP ACTIVATION FUNCTION</b> .....	76
<b>6</b>	<b>USER DATA</b> .....	<b>77</b>
6.1	<b>OPERATIONS</b> .....	77

6.1.1	<i>Image Files</i> .....	77
6.1.2	<i>Play Back</i> .....	78
6.1.3	<i>User Manual</i> .....	78
6.1.4	<i>Training</i> .....	79
6.1.5	<i>FAQ</i> .....	80
6.1.6	<i>Data Link Connector(DLC) Location</i> .....	80
<b>7</b>	<b>UPGRADE</b> .....	<b>81</b>
<b>8</b>	<b>SHOP INFORMATION</b> .....	<b>84</b>
8.1	WORKSHOP INFO.....	84
8.2	CUSTOMER INFO.....	85
8.2.1	<i>Customer Notes</i> .....	87
8.3	VEHICLE HISTORY.....	89
8.3.1	<i>Historical Test Record</i> .....	90
<b>9</b>	<b>SETTINGS</b> .....	<b>91</b>
9.1	UNIT.....	91
9.2	LANGUAGE.....	92
9.3	DATA LOG.....	93
9.4	WIFI.....	94
9.5	BRIGHTNESS.....	94
9.6	SCREEN SLEEP.....	95
9.7	VEHICLE SORTED BY.....	96
9.8	SYSTEM SETTINGS.....	97
9.9	CLICK TO RESTORE FACTORY SETTINGS.....	98
<b>10</b>	<b>QUICK LINK</b> .....	<b>99</b>
<b>11</b>	<b>FAULT CODE</b> .....	<b>100</b>
<b>12</b>	<b>SUPPORT</b> .....	<b>101</b>
12.1	ACCOUNT.....	101
12.2	DATA LOG.....	101
<b>13</b>	<b>UNINSTALL</b> .....	<b>104</b>
<b>14</b>	<b>REMOTE DESK</b> .....	<b>105</b>
<b>15</b>	<b>ABOUT</b> .....	<b>107</b>

<b>16</b>	<b>MAINTENANCE AND SERVICE.....</b>	<b>108</b>
16.1	MAINTENANCE INSTRUCTIONS.....	108
16.2	TROUBLESHOOTING CHECKLIST.....	109
16.3	ABOUT BATTERY USAGE.....	110
16.4	SERVICE PROCEDURES.....	111
16.4.1	<i>Technical Support</i> .....	111
16.4.2	<i>Repair Service</i> .....	111
16.4.3	<i>Other Services</i> .....	112
<b>17</b>	<b>COMPLIANCE INFORMATION.....</b>	<b>113</b>
<b>18</b>	<b>WARRANTY.....</b>	<b>116</b>
18.1	LIMITED ONE YEAR WARRANTY.....	116



# 1 Using this Manual

This manual contains device usage instructions.

Some illustrations shown in this manual may contain modules and optional equipment that are not included in your system.

## 1.1 Conventions

---

The following conventions are used.

### 1.1.1 Bold Text

Bold text is used to highlight selectable items such as buttons and menu options.

Example:

- Tap **OK**.

### 1.1.2 Notes and Important Messages

*Notes*

A **NOTE** provides helpful information such as additional explanations, tips, and comments.

Example:

---

#### **NOTE**

New batteries reach full capacity after approximately 3 to 5 charging and discharging cycles.

---

*Important*

**IMPORTANT** indicates a situation which, if not avoided, may result in damage to the tablet or vehicle.

Example:

---

**!** **IMPORTANT**

Keep the cable away from heat, oil, sharp edges and moving parts.  
Replace damaged cables immediately.

---

### **1.1.3 Hyperlink**

Hyperlinks, or links, that take you to other related articles, procedures, and illustrations are available in electronic documents. Blue italic text indicates a selectable hyperlink and blue underlined text indicates a website link or an email address link.

### **1.1.4 Illustrations**

Illustrations used in this manual are samples, the actual testing screen may vary for each vehicle being tested. Observe the menu titles and on-screen instructions to make correct option selection.

# 2 General Introduction

When it comes to ultra-portability, CR MAX is your perfect companion. Installed with a fast quad-core processor, CR MAX offers maximum convenience and swift diagnosis. The intuitive user screen makes using the device effortless through a 7-inch LCD touchscreen that displays at 1024 x 600 quality. Together with the ability to quickly read and clear DTCs for all available modules of the majority of the makes and models on the market, CR MAX provides you with superior special functions, including Oil Reset, EPB (Electronic Parking Brake), SAS (Steering Angle Sensor), BMS (Battery Management System), DPF (Diesel Particulate Filter), ABS Bleeding, ETC (Electronic Throttle Control) and Injector.

This manual describes the construction and operation of the device and how it works to deliver diagnostic solutions.

## 2.1 CR MAX Display Tablet

---

### 2.1.1 Functional Description

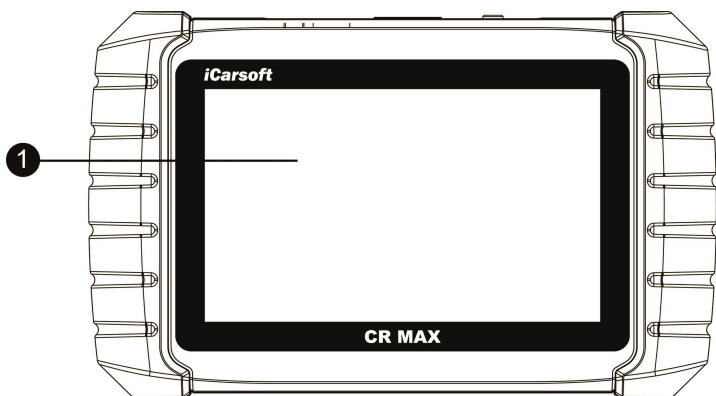

**Figure 2-1 Display Tablet Front View**

1. 7.0" LCD Capacitive Touchscreen

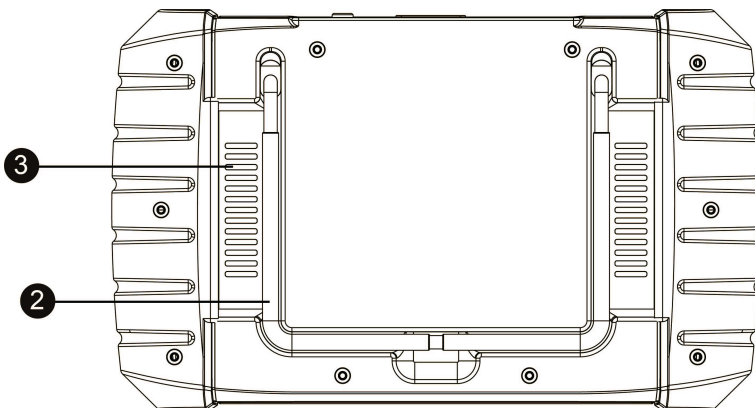

**Figure 2-2 CR MAX Display Tablet Back View**

- 2. Collapsible Stand – extends from the back to allow hands-free viewing of the Display Tablet.
- 3. Heat Sink or Speaker

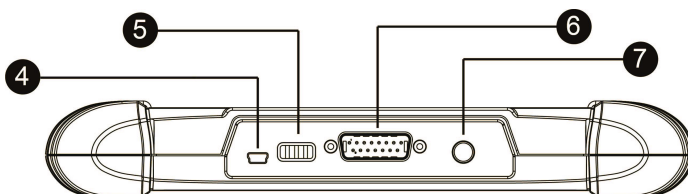

**Figure 2-3 CR MAX Display Tablet Top View**

- 4. Mini USB OTG Port
- 5.USB Host (Wireless has this interface, wired does not have this interface)
- 6. DB15-Pin Port – connects the main cable.
- 7. Lock/Power Button – long press button to turn tablet off and on. Quick press button to lock screen.

## 2.1.2 Power Sources

The Display Tablet can receive power from any of the following sources:

- Internal Battery Pack
- Vehicle Power
- External Power Supply

### *Internal Battery Pack*

The Display Tablet can be powered with the internal rechargeable battery, which if fully charged can provide sufficient power for about 4.5 hours of continuous operation.

### *Vehicle Power*

When the Display Tablet is connected to the test vehicle via the main cable, the Display Tablet automatically receives power from the vehicle.

### *External Power Supply*

The Display Tablet can be powered from a wall socket using the mini USB cable and USB external power adapter. The external power supply also charges the internal battery pack.

## **2.1.3 Technical Specifications**

**Table 2-1 Specifications**

<b>Item</b>	<b>Description</b>
<b>Recommended Use</b>	Indoor
<b>Operating System</b>	Android 8.1.0
<b>Processor</b>	4Nuclear 1.3 GHz
<b>Memory</b>	16GB
<b>Display</b>	7-inch LCD capacitive touchscreen with 1024x600 resolution

<b>Connectivity</b>	<ul style="list-style-type: none"> <li>• Mini USB 2.0</li> <li>• USB 2.0</li> <li>• Wi-Fi</li> <li>• Bluetooth</li> <li>• OBD II</li> </ul>
<b>Body Color</b>	Black
<b>Audio Input/ Output</b>	<ul style="list-style-type: none"> <li>• Input: N/A</li> <li>• Output: Buzzer &amp; Speaker</li> </ul>
<b>Power and Battery</b>	<ul style="list-style-type: none"> <li>• OBD DLC Voltage Range:9-18V</li> <li>• 3.7V/5000mAh lithium-polymer battery</li> <li>• Charges via 5 VDC power supply</li> </ul>
<b>Tested Battery Life</b>	Around 5 hours of continuous use
<b>Battery Charging Input</b>	5 V/2 A
<b>Power Consumption</b>	500mA (LCD on with default brightness, Wi-Fi on) @3.7 V
<b>Operating Temp.</b>	0 to 50°C (32 to 122°F)
<b>Storage Temp.</b>	-20 to 70°C (-4 to 158°F)
<b>Operating Humidity</b>	5% - 95% non-condensing
<b>Dimensions (W x H x D)</b>	240.0mm*150.0mm*35.0mm
<b>Net Weight</b>	750 g
<b>Supported Automotive Protocols</b>	ISO9141-2, ISO14230-2,ISO15765, K/L-Line, Flashing Code, SAE-J1850 VPW, SAE-J1850 PWM, ISO11898(Highspeed, Middlespeed, Lowspeed and Singlewire CAN, fault-tolerant CAN), SAE J2610,GM UART,UART Echo Byte Protocol, Honda Diag-H Protocol, TP2.0, TP1.6

## 2.2 Accessory Kit

---





### 2.2.1 Main Cable

The Main Cable connects the Display Tablet to the vehicle's data link connector (DLC).



**Figure 2-4 Main Cable**

### 2.2.2 Other Accessories

	<p><b>Mini USB Cable</b> Connects the Display Tablet to the PC or DC external power adapter.</p>
	<p><b>USB External Power Adapter</b> Together with the mini USB cable, connects the Display Tablet to the external DC power port for power supply.</p>
	<p><b>User Manual</b> Tool operations instructions.</p>
	<p><b>Quick Guide</b> Device connection and diagnostic software update instructions.</p>

# 3 Getting Started

Ensure the tablet is sufficiently charged or is connected to the external power supply (see *Power Sources* on page 5).

---

## NOTE

The images and illustrations depicted in this manual may differ from the actual ones.

---

## 3.1 Powering Up

---

Press the Lock/Power button on the top right side of the tablet to power the unit on. The system boots up, and displays the lock screen. Slide the lock icon up and down to access the CR Max job menu.

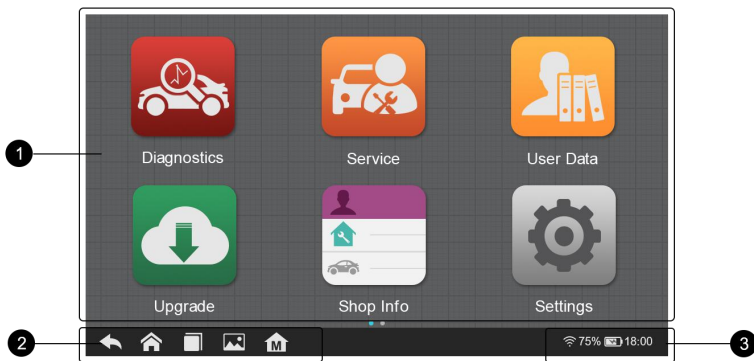

**Figure 3-1 Sample CR MAX Job Menu**

1. Application Buttons
2. Locator and Navigation Buttons
3. Status Icons

---

## NOTE

The tablet screen is locked by default upon startup. It is recommended to lock the screen when not in use to protect the



information in the system and conserve the power.







---







Almost all operations on the tablet are controlled through the touchscreen. The touchscreen navigation is menu driven, which allows you to quickly locate the test procedure, or data that you need, through a series of choices and questions. Detailed descriptions of the menu structures are found in the chapters for each application.

### 3.1.1 Application Buttons

The tablet below briefly describes each of the applications in the CR MAX system.

**Table 3-1 Applications**







Button	Name	Description
	<b>Diagnostics</b>	Accesses diagnostic functions menu. See Diagnostics Operations on page 13.
	<b>Service</b>	Accesses special functions menu. See Service Operations on page 35.
	<b>User Data</b>	Accesses the organization system for saved data files. See User Data Operations on page 65.
	<b>Upgrade</b>	Checks for the latest update available for the CR MAX system, and performs updates. See Upgrade Operations on page 69.
	<b>Shop Information</b>	Accesses the workshop information service program, including customer information records and test vehicle history records. See Shop Manager Operations on page 72.
	<b>Settings</b>	Accesses CR MAX system settings menu and general tablet menu. See Settings Operations on page 79.

Button	Name	Description
	<b>Quick Link</b>	Provides associated website bookmarks to allow quick access to product update, service, support and other information. See Quick Link Operations on page 87.
	<b>Fault Code</b>	Allows the user to query the fault information of the vehicle model according to the fault code. See Fault Code Operations on page 88.
	<b>Support</b>	Launches the Support platform which synchronizes iCarsoft's on-line service base station with the CR MAX tablet. See Support Operations on page 89.
	<b>Uninstall</b>	Manage the firmware applications installed on the CR MAX Diagnostics System. See Uninstall Operations on page 92.
	<b>Remote desk</b>	Configures the unit to receive remote support using the TeamViewer application program. See Remote Desk Operations on page 93.
	<b>About</b>	Access CR MAX system information about the machine. See About Operations on page 95.

### 3.1.2 Locator and Navigation Buttons

Operations of the Navigation buttons at the bottom of the screen are described in the table below:

**Table 3-2 Locator and Navigation Buttons**

Button	Name	Description
	<b>Locator</b>	Indicates the location of the screen. Swipe the screen left or right to view the previous or next screen.
	<b>Back</b>	Returns to the previous screen.
	<b>Android Home</b>	Returns to Android System's Home screen.
	<b>Recent Apps</b>	Displays a list of applications that are currently in use. Tap an app icon to launch. To remove an app, swipe it to the top or bottom.
	<b>Screenshot</b>	Takes a screenshot when you want to save the displayed information.
	<b>CR MAX Home</b>	Returns to CR MAX Job Menu.

## 3.2 Powering Down

All vehicle communications must be terminated before shutting down the Display Tablet. A warning message displays if a shutdown is attempted while the tablet is communicating with the vehicle. Forcing a shutdown while the tablet is communicating may lead to ECM problems on some vehicles. Please exit the Diagnostics application before shutting off the tablet.

➤ **To power down the display tablet**

1. Long press the Lock/Power Button.
2. Tap Power off option.

3. Tap OK, the tablet will turn off in a few seconds.

### **3.2.1 Reboot System**

In case of system crash, long press the Lock/Power button and tap Reboot option to restart the system.

# 4 Diagnostics

The Diagnostics application can access the electronic control unit (ECU) of various vehicle control systems, such as engine, transmission, anti-lock brake system (ABS), airbag system (SRS) and more.

## 4.1 Getting Started

The Diagnostics operations require connecting the CR MAX to the test vehicle's DLC using the main cable.

### 4.1.1 Vehicle Menu Layout

When the tablet is properly connected to the vehicle, the platform is ready to start vehicle diagnosis. Tap on the Diagnostics application button on the CR MAX Job Menu, the Vehicle Menu then displays.

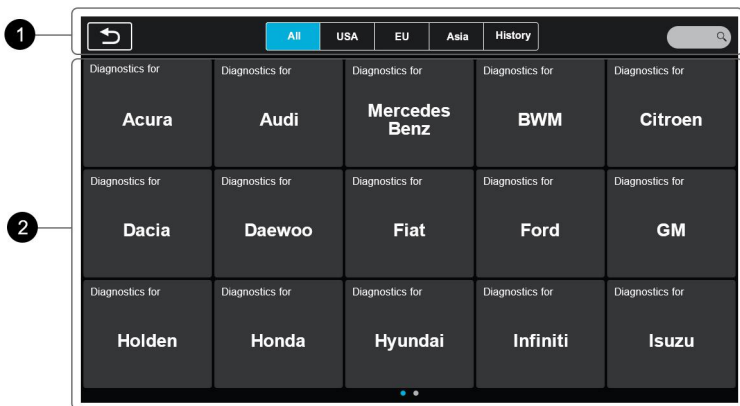







**Figure 4-1 Sample Vehicle Menu**

1. Top Toolbar Buttons
2. Manufacturer Buttons

*Top Toolbar Buttons*

The operations of the toolbar buttons at the top of the screen are listed and described in the table below:

**Table 4-1 Top Toolbar Buttons**

Button	Name	Description
	<b>Home</b>	Returns to the CR MAX Job Menu.
	<b>All</b>	Displays a menu of vehicle manufacturers.
	<b>History</b>	Displays stored test vehicle history records. Tap record to review record in detail. See <i>Vehicle History</i> on page 77.
	<b>USA</b>	Displays the USA vehicle menu.
	<b>Europe</b>	Displays the European vehicle menu.
	<b>Asia</b>	Displays the Asian vehicle menu.
	<b>Search</b>	Searches for a specific vehicle make.

### *Manufacturer Buttons*

The vehicle manufacturer buttons display the vehicle brands currently compatible with the tool. After establishing communication with the vehicle. Tap the desired manufacturer button to start a diagnostic session.

## **4.2 Vehicle Identification**

---

The CR MAX diagnostic system supports four methods for Vehicle Identification.

1. Auto VIN Scan
2. Manual VIN Input

3. Smart Scan
4. Manual Selection

## 4.2.1 Auto VIN Scan

The CR MAX diagnostic system features the latest VIN-based Auto VIN Scan function to identify vehicles with just one touch, enabling the technician to quickly identify the vehicle, scan all the diagnosable ECUs on the vehicle and perform diagnostics on the selected system.

### ➤ To perform Auto VIN Scan

1. Tap the **Diagnostics** application button from the CR MAX Job Menu. The Vehicle Menu displays.

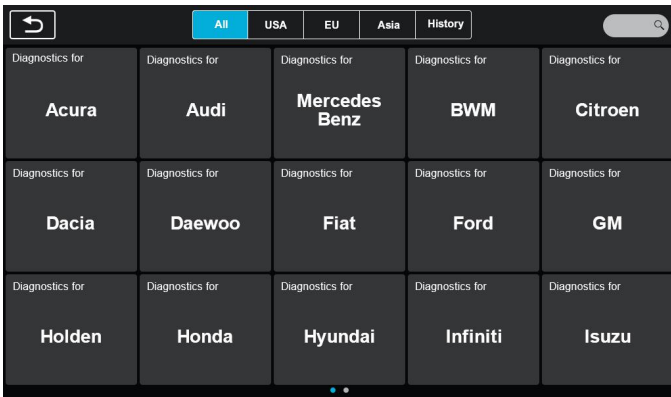

**Figure 4-2 Sample Auto VIN Screen 1**

2. Select **vehicle brand**. Whether the interface of VIN code recognition will be different for different car brands. Once the test vehicle is successfully identified, the screen will display the Vehicle Identification Number (VIN), tap **OK** at the bottom right to confirm. If the VIN does not match, enter the VIN manually or tap **Read** to acquire VIN again.

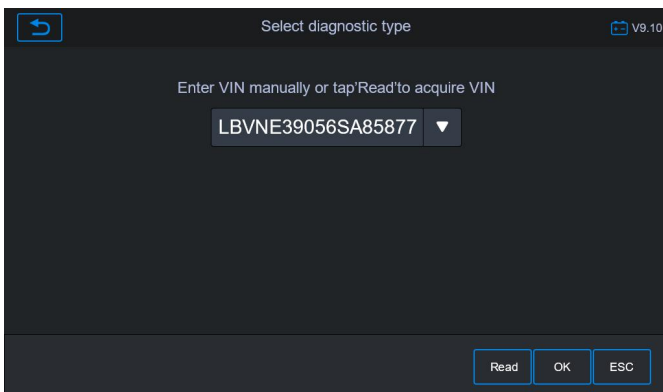

**Figure 4-3 Sample Auto VIN Screen 2**

3. Review the information to ensure it is correct. Tap Yes to confirm the vehicle or NO if the information is not correct.

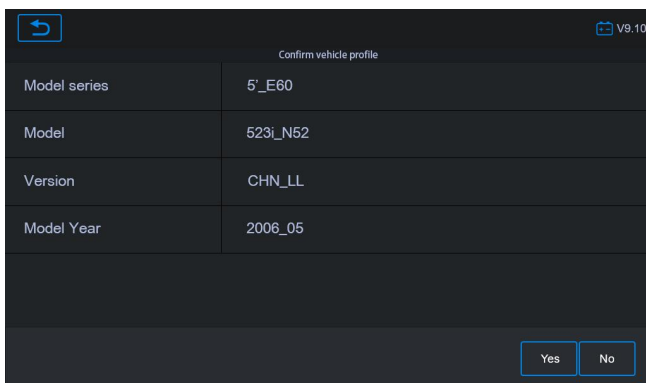

**Figure 4-4 Sample Vehicle Profile Screen**

4. The tool will establish communication with the vehicle to read control unit information. Choose Smart Scan to scan all the available systems of the test vehicle or tap Manual to access the system that you want to diagnose.

## 4.2.2 Manual VIN Input



For some vehicles that not supporting the Auto VIN Scan function, the CR MAX diagnostic system allows you to enter the vehicle VIN manually.

➤ **To perform Manual VIN Input**

1. Tap the **Diagnostics** application button from the CR MAX Job Menu. The Vehicle Menu displays.
2. Select **vehicle brand**. Whether the interface of VIN code recognition will be different for different car brands. If some vehicles do not support automatic VIN code recognition, you need to enter the VIN code manually.
3. Tap the input box and enter the correct VIN.

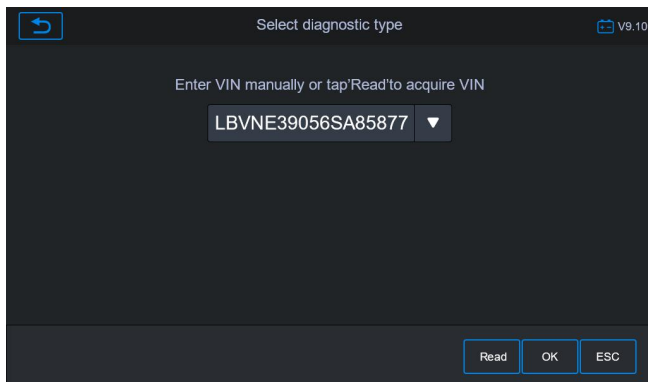

**Figure 4-6 Sample Diagnostic Screen**

4. Tap Done. The vehicle will be identified and the Vehicle Diagnostics screen will display.
5. Tap Cancel to exit Manual Input.

### **4.2.3 Smart Scan**

In some cases, when the user selects the vehicle brand and does not perform automatic vehicle identification number scanning, the system can provide a smart scan to scan the vehicle identification

number.

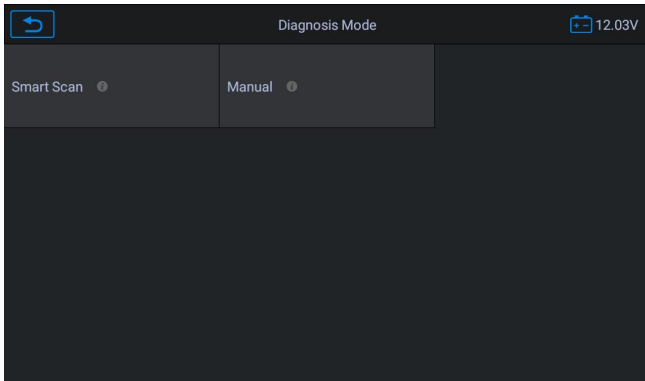

**Figure 4-7 Sample Selection Screen**

➤ **To perform Automatic Selection**

1. Tap the Diagnostics application button from the CR MAX Job Menu. The Vehicle Menu displays.
2. Tap the vehicle brand of the test vehicle.
3. Tap Smart Scan and the system will proceed to acquire the VIN. Follow the on-screen instruction to access the diagnostic screen.

#### **4.2.4 Manual Selection**

When the vehicle's VIN is not automatically retrievable through the vehicle's ECU, or the specific VIN is unknown, you can choose to select the vehicle manually.

This mode of vehicle selection is menu driven, repeat the first two steps from the automatic selection operation and tap Manual Selection. Follow the on-screen prompts to make a series of choices to select the correct vehicle. Press the **Back** button at the bottom right corner of the screen to return to the previous step. Exact procedures may vary by vehicle.

## 4.3 Navigation

---

This section describes how to operate the Diagnostics screen and select test options.

### 4.3.1 Diagnostics Screen Layout

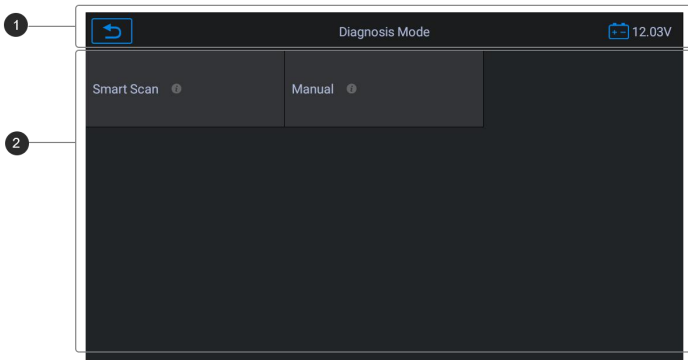

**Figure 4-7 Sample Diagnostics Screen**

The diagnostic screens typically include four sections.

1. Status Information Bar
2. Main Section

#### **Status Information Bar**

The Status Information Bar at the top of the Main Section displays the following items:

1. Back button--- Returns to the CR MAX Job Menu.
2. Menu Title – displays the menu heading of the Main Section.
3. Voltage Icon – displays the vehicle's voltage status.

#### **Main Section**

The Main Section of the screen varies depending on the stage of operations. The Main Section can display vehicle identification selections, the main menu, test data, messages, instructions and other diagnostic information.

## ***Functional Buttons***

The displayed Functional Buttons vary depending on the stage of operations. Functional buttons can be used to navigate menus, to save or clear diagnostic data, to exit scanning and to perform a number of other control functions. The use of these buttons will be discussed in detail in the following sections of the corresponding test operations.

### **4.3.2 Screen Messages**

Screen messages appear when additional input is needed before proceeding. There are three main types of on-screen messages: Confirmation, Warning, and Error.

#### ***Confirmation Messages***

This type of messages usually displays as an “Information” screen that informs you when you are about to perform an action that cannot be reversed or when an action has been initiated and your confirmation is needed to continue.

When a user-response is not required to continue, the message displays briefly.

#### ***Warning Messages***

This type of messages displays a warning that a selected action may result in an irreversible change or loss of data. The typical example of this is the “Erase Codes” message.

#### ***Error Messages***

Error messages display when a system or procedural error has occurred. Examples of possible errors include a disconnection or communication interruption.

### **4.3.3 Making Selections**

The Diagnostics application is a menu driven program that presents a series of choices. As a selection is made, the next menu in the series displays. Each selection narrows the focus and leads to the desired test. Tap the screen to make menu selections.

## 4.4 Diagnosis

---

The Diagnostics application enables a data link to the electronic control system of the test vehicle for vehicle diagnosis. The application performs functional tests, retrieves vehicle diagnostic information such as trouble and event codes and live data for various vehicle control systems, such as engine, transmission, and ABS.

There are two options available when accessing the Diagnosis section:

1. Smart Scan – starts smart scanning for all the available systems on the vehicle.
2. Manual – displays a selection menu of all available of the test vehicle.

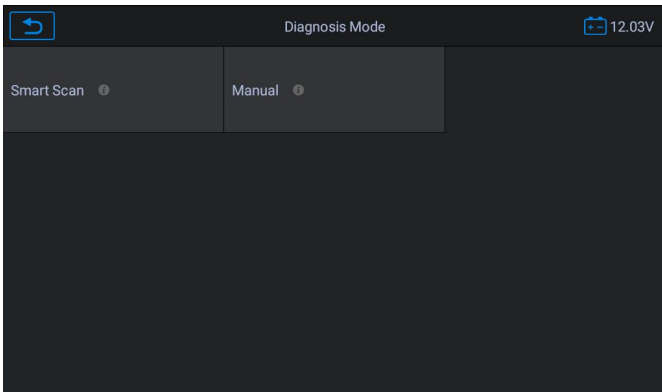
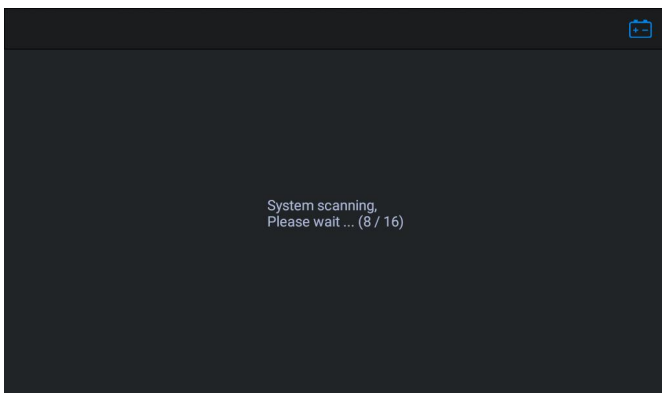

**Figure 4-8 Sample Diagnosis Mode Screen**

After a section is made and the tablet establishes communication with the vehicle, the corresponding function menu or selection menu displays.

### 4.4.1 Smart Scan

The Smart Scan function performs a comprehensive scanning of the ECUs in the vehicle's system to locate and retrieve DTCs. The sample operation screen of Smart Scan displays as below:



**Figure 4-9 Sample Auto Scan Operation Screen**

Enter Smart Scan, the system will scan your vehicle's system for you.

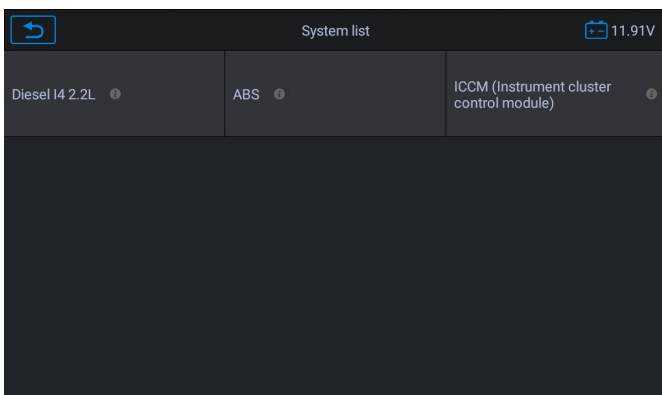

**Figure 4-10 Sample Auto Scan Operation Screen**

### *Functional Buttons*

A brief description of the operations of the Smart Scan's Functional Buttons' are displayed in the table below.

**Table 4-3 Functional Buttons in Auto Scan**

Name	Description
Back	Returns to the previous screen or exits Auto Scan.

## 4.4.2 Manual

This option allows you to manually locate a required control system for testing through a series of choices. Follow the menu driven procedures and make proper selection each time; the program will guide you to the diagnostic function menu after selections are made.

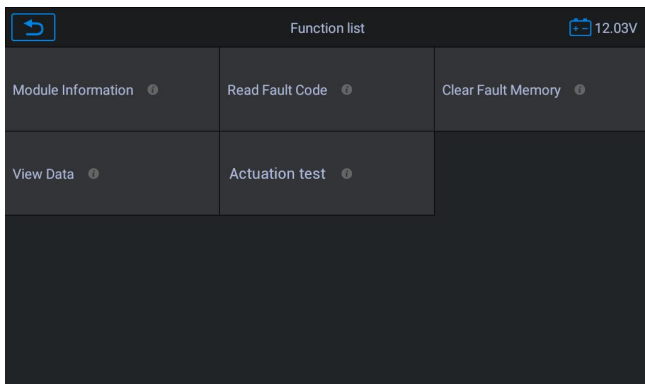

**Figure 4-11 Sample Function Menu**

The Function Menu options vary slightly for different vehicles. The function menu may include:

- **Module Information** – Read full electronic system module information, such as VIN, part number, version, supplier, production date of ECU.
- **Read fault code** – Read full electronic system module fault code, show state and description of fault code.
- **Clear fault Memory** – Erase full electronic system module fault code and diagnostic related freeze frame information.
- **View data** – Read full electronic system module live data by text value or waveform.

- **Actuation Test** -- Through this function can be sent to the car instructions, such as lifting Windows, lifting chair, and so on, these functions vary from model to model.
- **To perform a diagnostic function**
  1. Establish communication with the test vehicle.
  2. Identify the test vehicle by selecting from the menu options.
  3. Select the **Diagnosis** section.
  4. Locate the required system for testing by **Smart Scan** or through menu driven selections in **Manual**.
  5. Select the desired diagnostic function from the **Function Menu**.

## Module Information

This function retrieves and displays the specific information for the tested control unit, including unit type, version numbers and other specifications.

The sample Module Information screen displays as below:

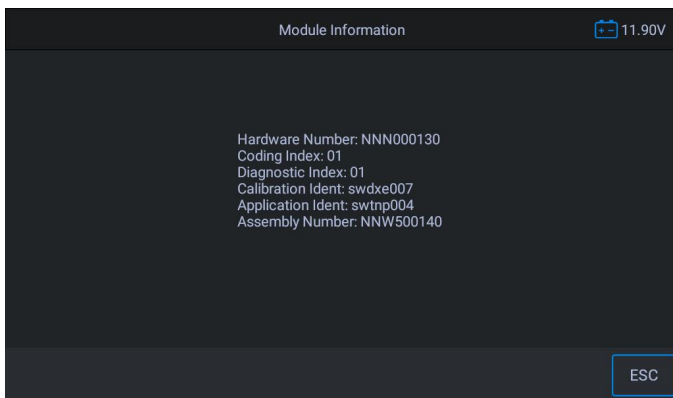

**Figure 4-12 Sample Module Information Screen**

## Read Fault Codes



This function retrieves and displays the DTCs from the vehicle's control system. The Read Codes screen varies for each vehicle being tested. On

some vehicles, freeze frame data can also be retrieved for viewing. The sample Read Codes screen displays as below:

Read Fault Code		
P0100	State: Short Circuit to Ground	Mass or Volume Air flow Circuit Malfunction
P0101	State: Short Circuit to Ground	Mass or Volume Air flow Circuit Range/Performance Problem
P0102	State: Short Circuit to Ground	Mass or Volume Air Flow Circuit low Input
P0103	State: Short Circuit to Ground	Mass or Volume Air flow Circuit High Input
	State: Short	

**Figure 4-13 Sample Read Fault Codes Screen**

Functional Button

- Save – tap this icon to save the information related to the fault code
- Back – tap it to return to the previous screen or exit the function.

## Clear Fault Codes

After reading the retrieved codes from the vehicle and certain repairs have been carried out, you can erase the codes from the vehicle using this function.

Before performing this function, make sure the vehicle's ignition key is in the ON (RUN) position with the engine off.

### ➤ To erase codes

1. Tap **Clear Fault Codes** from the Function Menu.
2. A warning message displays to inform you of data loss if this

function is completed.

- a) Tap **Yes** to continue. A confirming screen displays when the operation is successfully done.
  - b) Tap **No** to exit.
3. Tap **ESC** on the confirming screen to exit Erase Codes.
  4. Perform the Read Codes function again to check if codes have been erased successfully.

## View Data

When this function is selected, the screen displays the data list for the selected module. The items available for any control module vary from one vehicle to another. The parameters display in the order that they are transmitted by the ECM, so expect variation between vehicles.

Gesture scrolling allows you to quickly move through the data list. Simply swipe the screen up or down to locate the data you want. The figure below shows a typical Live Data screen:

The screenshot shows a table with three columns: Name, Value, and Unit. The table contains five rows of data. A callout '1' points to the first row, and a callout '2' points to the bottom navigation bar.

Name	Value	Unit
<input type="checkbox"/> Number of trouble codes set due to diagnostic test	0	
<input type="checkbox"/> Wheel speed - Front left wheel speed	N/A	km/h
<input type="checkbox"/> Wheel speed - Front right wheel speed	N/A	km/h
<input type="checkbox"/> Wheel speed - Rear left wheel speed	N/A	km/h
<input type="checkbox"/> Wheel speed - Rear right wheel speed	N/A	km/h

The bottom navigation bar contains the following icons from left to right: back, Show selected, Graph Merge, To Top, Clear Data, Freeze, and Record.

**Figure 4-14 Sample Live Data Screen**

### 1. Main Section

- Name Column – displays the parameter names.
  - a) Check Box – tap the check box on the left side of the

parameter name to make item selection. Tap the check box again to de-select the item.

- b) Drop-down Button – tap the drop-down button on the right side of the parameter name to open a sub menu that provides various choices for data display mode.
- Value Column – displays the values of the parameter items.
- Unit Column – displays the unit for the parameters.
- To change the unit mode, return to the “Settings” button and select the desired mode.

### **Display Mode**

There are four types of display modes available for data viewing, allowing you to view various types of parameters in the most suitable way.

Tapping the drop-down button on the right side of the parameter name to open a sub menu. There are four buttons to configure the data display mode, and a Help button for access to additional information.

Each parameter item displays the selected mode independently.

- 1) Analog Gauge Mode – displays the parameters in form of an analog meter graph.
- 2) Text Mode – this is the default mode that displays the parameters in texts and displays in list format.

---

#### **NOTE**

Reading of status parameters, such as a switch reading, which are mostly in word form, such as ON, OFF, ACTIVE, and ABORT, can only be displayed in Text Mode. Whereas reading of value parameters, such as a sensor reading, can be displayed in text mode and other graph modes.

---

- 3) Waveform Graph Mode – displays the parameters in waveform graphs.

When this mode is applied, you can use two fingers to zoom in or out.

4) Digital Gauge Mode – displays the parameters in form of a digital gauge graph.

## 2. Functional Buttons

The operations of available functional buttons on Live Data screen are described below:

**Back** – returns to previous screen or exits the function.

**Record** – starts recording the retrieved live data; the recorded data is then stored as a video clip in the Data Manager application for future reviews. This function could be triggered automatically at preset threshold value or manually as you choose. The triggering mode and record duration can be configured in the Setting mode of Live Data.

**Freeze frame** – displays the retrieved data in freeze frame mode.

- Previous Frame – moves to the previous frame in the freeze frame data.
- Next Frame – moves to the next frame in the freeze frame data.

**Clear Data** – clears all previously retrieved parameter values at a selected point.

**To Top** – moves a selected data item to the top of the list.

**Graph Merge** – tap this button to merge selected data graphs (for Waveform Graph Mode only). This function is useful when making a comparisons between parameters.

---

### NOTE

This mode supports Graph Merge for 3 to 4 parameter items. Up to 4 parameter items combined.

---

- To cancel Graph Merge mode, tap the  button in the upper

right corner.

**Show** – tap this option to switch between the two options; one displays the selected parameter items, the other displays all the available items.

## 4.5 Generic OBD II Operations

---

4.4 A fast-access option for OBD II/EODB vehicle diagnosis is available on the Vehicle Menu screen. This option presents a quick way to check for DTCs, isolate the cause of an illuminated malfunction indicator lamp (MIL), check monitor status prior to emissions certification testing, verify repairs, and perform a number of other services that are emissions-related. The OBD direct access option is also used for testing OBD II/EODB compliant vehicles that are not included in the Diagnostics database.

Functions of the diagnostics toolbar buttons at the top of the screen are the same as those available for specific vehicle diagnostics. See *Table 4-2 Diagnostics Toolbar Buttons* on page 21 for details.

### 4.5.1 General Procedure

➤ **To access the OBD II/EODB diagnostics functions**

1. Tap the **Diagnostics** application button from the CR MAX Job Menu. The Vehicle Menu displays.
2. Tap the **EOBD** button. There are two options to establish communication with the vehicle.
  - **Auto Scan** – when this option is selected the diagnostic tool attempts to establish communication using each protocol in order to determine which one the vehicle is broadcasting on.
  - **Protocol** – when this option is selected the screen opens a submenu of protocols. A communication protocol is a standardized way of data communication between an ECM and a diagnostic tool. Global OBD

may use several different communication protocols.

3. Select a specific protocol under the **Protocol** option. Wait for the OBD II Diagnostic Menu to display.

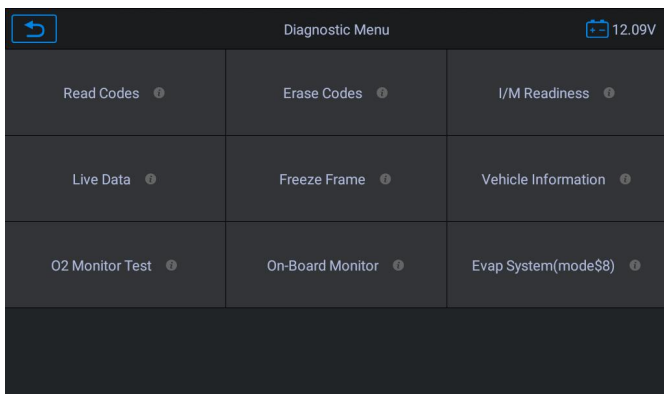

**Figure 4-15 Sample OBD II Diagnostic Menu**

---

**NOTE**

Tapping the (i) button beside the function name to display additional function information.

4. Select a function option to continue.

- **Read Codes**
- **Erase Codes**
- **I/M Readiness**
- **Live Data**
- **Freeze Frame**
- **Vehicle Information**
- **Monitor Test**
- **On-Board Monitor**
- **Evap System(mode\$8)**

---

**NOTE**

Some functions are supported only on certain vehicle manufacturers.

---

## 4.5.2 Function Descriptions

This section describes the various functions of each diagnostic option:

### **Read Codes**

When this function is selected, the screen displays a list of Stored Codes and Pending Codes. You can save the fault code information of the current page through the save button in the lower right corner.

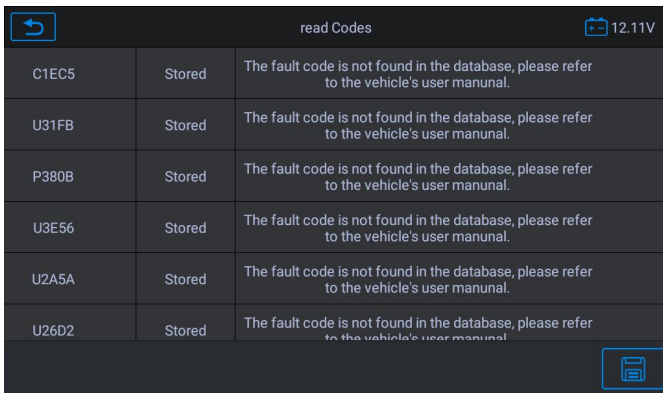

read Codes		
C1EC5	Stored	The fault code is not found in the database, please refer to the vehicle's user manual.
U31FB	Stored	The fault code is not found in the database, please refer to the vehicle's user manual.
P380B	Stored	The fault code is not found in the database, please refer to the vehicle's user manual.
U3E56	Stored	The fault code is not found in the database, please refer to the vehicle's user manual.
U2A5A	Stored	The fault code is not found in the database, please refer to the vehicle's user manual.
U26D2	Stored	The fault code is not found in the database, please refer to the vehicle's user manual.

**Figure 4-16 Sample DTC & FFD Screen**

Stored codes are the current emission related DTCs from the ECM of the vehicle. OBD II/EOBD Codes have a priority according to their emission severity, with higher priority codes overwriting lower priority codes. The priority of the code determines the illumination of the MIL and the codes erase procedure. Manufacturers rank codes differently, so expect to see differences between makes.

### **Erase Codes**

This option is used to clear all emission related diagnostic data such as, DTCs, freeze frame data and manufacturer specific enhanced data from the vehicle's ECM.

A confirmation screen displays when the clear codes option is selected to prevent accidental loss of data. Select Yes on the confirmation screen to continue or No to exit.

## ***I/M Readiness***

This function is used to check the readiness of the monitoring system. It is an excellent function to use prior to having a vehicle inspected for compliance to a state emissions program. Selecting I/M Readiness opens a submenu with two choices:

- **Since DTCs Cleared** – displays the status of monitors since the last time the DTCs are erased.
- **This Driving Cycle** – displays the status of monitors since the beginning of the current drive cycle.

## ***Live Data***

This function displays the real time PID data from ECU. Displayed data includes analog inputs and outputs, digital inputs and outputs, and system status information broadcast on the vehicle data stream.

Live data can be displayed in various modes, see Live Data on page 29 for detailed information.

## ***Freeze Frame***

In most cases the stored frame is the last DTC that occurred. Certain DTCs, which have a greater impact on vehicle emission, have a higher priority. In these cases, the top prioritized DTC is the one for which the freeze frame records are retained. Freeze frame data includes a “snapshot” of critical parameter values at the time the DTC is set.

## ***Vehicle Information***

The option displays the vehicle identification number (VIN), the calibration identification, and the calibration verification number (CVN), and other information of the test vehicle.

## ***Monitor Test***

This service enables bi-directional control of the ECM so that the diagnostic tool is able to transmit control commands to operate the vehicle systems. This function is useful in determining whether the ECM responds to a command well.



### ***On-Board Monitor***

This option allows you to view the results of On-Board Monitor tests. The tests are useful after servicing or after erasing a vehicle's control module memory.

### ***Evap System(mode\$8)***

This item is used to issue the EVAP system test command.

## **4.6 Exiting Diagnostics**

---

The Diagnostics application remains open as long as there is active communication with the vehicle. You must exit the diagnostics operation to stop all communications with the vehicle before closing the Diagnostics application.

---

### **NOTE**

Damage to the vehicle electronic control module (ECM) may occur if communication is disrupted. Make sure all connections, such as USB cable and wireless connections, are properly connected at all times during testing. Exit all tests before disconnecting the test connection or powering down the tool.

---

#### **➤ To exit the Diagnostics application**

1. From an active diagnostic screen, tap the **Back** or **ESC** functional button to exit a diagnostic session step-by-step.
2. From the Vehicle Menu screen, tap the **Back** button on the top toolbar; or tap the **Back** button on the navigation bar at the bottom of the screen.
3. Or tap the **Home** button on the diagnostics toolbar to exit the application directly and return to the CR MAX Job Menu.

Once the Diagnostics application is no longer communicating with the vehicle, it is safe to open other CR MAX applications, or exit the CR MAX Diagnostic System and return to the Android System's Home screen.

# 5 Service Operations

The Service section is specially designed to provide you with quick access to the vehicle systems for various scheduled service and maintenance performances. The typical service operation screen is a series of menu driven executive commands. By following the on-screen instructions to select appropriate execution options, enter correct values or data, and perform necessary actions, the system will guide you through the complete performance for various service operations.

The most commonly performed service functions include:

- ABS Bleeding Service
- Oil Reset Service
- EPB Service
- Electronic Throttle Control Service
- Injector Service
- SAS Service
- BMS Service
- DPF Service
- AFS Head Lamp reset
- Air Suspension
- TPMS programming service
- Gearbox Reset
- Air conditioning service
- Air Filter Self-learning process after replacing the air filter.
- Fuel Pump activation function

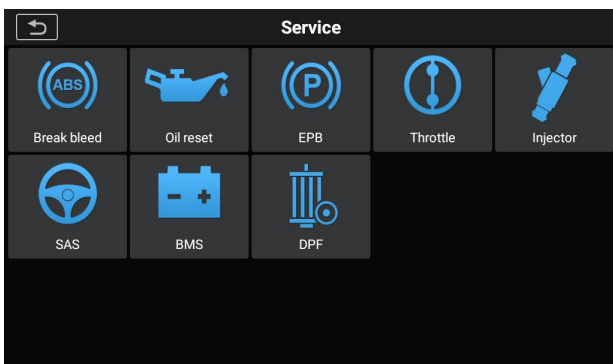

**Figure 5-1 Sample Service Function List**

After entering each special function, the displayed screen consists of two applications: **Diagnosis** and **Hot Functions**. The **Diagnosis** is for you to read/clear data since this is necessary after some special functions. **Hot Functions** consists of sub functions of the selected special function.

## 5.1 Brake Bleed

When the ABS contains air, or the ABS computer / ABS pump / brake master cylinder / brake cylinder/ brake fluid is replaced, the ABS bleeding function must be performed to bleed the brake system to restore ABS brake sensitivity.

### NOTE

This operation requires assistance.

Using **BMW** as an example:

#### ➤ To perform Brake bleed functions

1. Tap the **Service** application button from the CR MAX Job Menu.
2. Tap **Brake bleed** button and wait for the vehicle manufacturer screen. You can tap **VIN Scan** or the vehicle make to acquire vehicle VIN information and tap **Yes** to

confirm. See *Vehicle Identification* on page 14 for detail.

3. Tap the function you want in the brake bleed function list, the list may vary for different vehicles being tested.

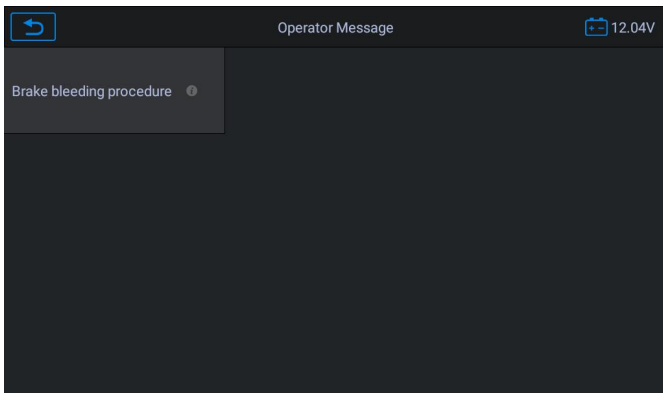

**Figure 5-2 Sample Brake Bleed Function Screen 1**

4. Read the operation information on the screen carefully, carry out the preparatory work according to the requirements of the screen, connect the brake fluid change device, and connect the exhaust valve to the left rear valve.

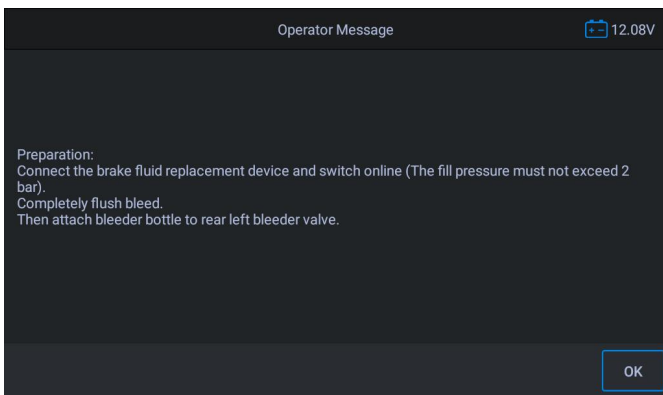

**Figure 5-3 Sample Brake Bleed Function Screen 2**

5. Start to exhaust the left rear wheel. This process requires a

person sitting in the car to step on the brake pedal every 3 seconds. This process needs a certain time. Press the OK key in the lower left corner of the screen to continue.

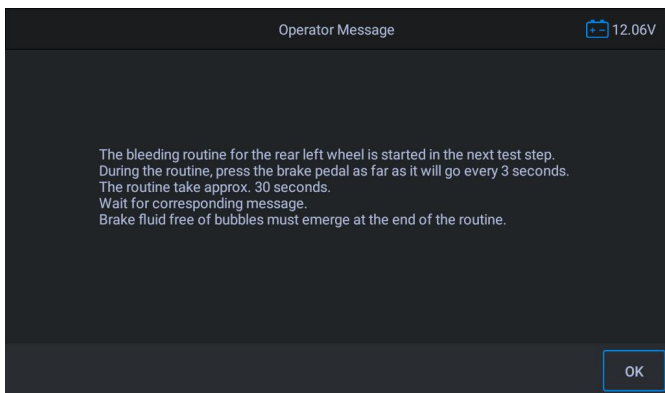

**Figure 5-4 Sample Brake Bleed Function Screen 3**

6. After the exhaust of the left rear wheel is completed, the screen will prompt to connect the exhaust bottle to the left exhaust valve and perform the same operation as the exhaust of the left rear wheel. Press OK to exit until the application is complete on the screen

## 5.2 Oil Reset Service

---

This function allows you to perform reset for the Engine Oil Life system, which calculates an optimal oil life change interval depending on the vehicle driving conditions and climate. The Oil Life Reminder must be reset every time the oil is changed, so the system can calculate when the next oil change is required.

---

### **!** IMPORTANT

Always reset the engine oil life to 100% after every oil change.

---

### **🔧** NOTE

All required work must be carried out before the service indicators

are reset. Failure to do so may result in incorrect service values and cause DTCs to be stored by the relevant control module.

---

## NOTE

For some vehicles, the scan tool can perform added functionality to reset additional service lights (maintenance cycle, service interval). Using BMW as an example, its service reset function includes engine oil, spark plugs, front/rear brakes, coolant, particle filter, brake fluid, micro filter, vehicle inspection, exhaust emission inspection and vehicle check.

---

All software screens shown in this manual are examples, actual test screens may vary for each vehicle being tested. Observe the menu titles and on-screen instructions to make correct option selections.

### ➤ To perform oil reset functions

1. Tap the **Service** application button from the CR MAX Job Menu.
2. Tap **Oil Reset** button and wait for the vehicle manufacturer screen. You can tap **VIN Scan** or the vehicle make to acquire vehicle VIN information and tap **Yes** to confirm. See *Vehicle Identification* on page 14 for detail.
3. Tap the function you want in the Oil Reset function list, the list may vary for different vehicles being tested.

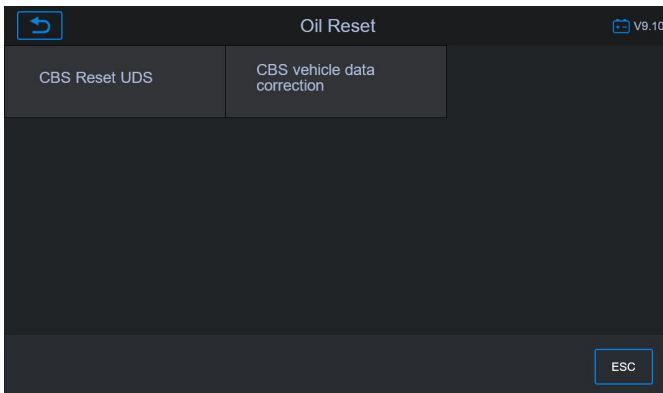

### Figure 5-5 Sample Oil Reset Function List

4. Follow the step-by-step on-screen instruction to complete the service. Using CBS Reset UDS as an example.
5. Tap **CBS Reset UDS** on the Oil Reset function list to start the operation. The screen will guide you to confirm the date and time, if the displayed date and time are correct, tap **Yes** to confirm. If not, tap **No** and go to the Settings menu to set the correct date and time.

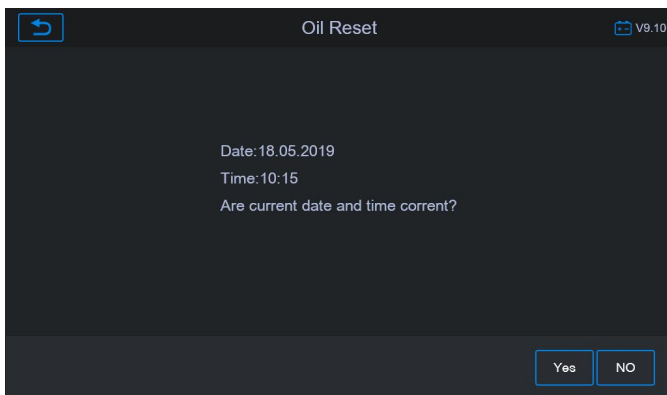

### Figure 5-6 Sample Oil Reset Service Screen 1

6. On the next screen, the available items would be listed with three columns displayed: CBS value, availability, and service counter.

CBS value	availability	service counter
Engine Oil	32%	5
Front Brake	97%	9
Rear Brake	96%	6

Reset ESC

**Figure 5-7 Sample Oil Reset Service Screen 2**

7. Tap on the value you want to reset and then tap the **Reset** button on the right bottom of the screen.

Engine Oil	32%	5
Front Brake	97%	9
Rear Brake	96%	6
Brake fluid	100%	6

Reset ESC

**Figure 5-8 Sample Oil Reset Service Screen 3**

8. When the reset is done, the availability would display as 100%. Tap **ESC** to exit.

## **5.3 Electronic Parking Brake (EPB) Service**

This function has a multitude of usages to maintain the electronic



braking system safely and effectively. The applications include deactivating and activating the brake control system, assisting with brake fluid control, opening and closing brake pads, and setting brakes after disc or pad replacement.

### 5.3.1 EPB Safety

It may be dangerous to perform Electronic Parking Brake (EPB) system maintenance, so before you begin the service work, please keep these rules in mind.

- ✓ Ensure that you are fully familiar with the braking system and its operation before commencing any work.
- ✓ The EPB control system may be required to be deactivated before carrying out any maintenance/diagnostic work on the brake system. This can be done from the tool menu.
- ✓ Only carry out maintenance work when the vehicle is stationary and on level ground.
- ✓ Ensure that the EPB control system is reactivated after the maintenance work has been completed.

---

#### NOTE

ICarsoft accepts no responsibility for any accident or injury arising from the maintenance of the Electronic Parking Brake system.

---

#### ➤ To perform EPB functions

1. Tap the **Service** application button from the CR MAX Job Menu.
2. Tap **EPB** button and wait for the vehicle manufacturer screen. You can tap **VIN Scan** or the vehicle make to acquire vehicle VIN information and tap **Yes** to confirm. See *Vehicle Identification* on page 14 for detail.
3. Tap the service you want in the EPB function list, the list may vary for different vehicles being tested.

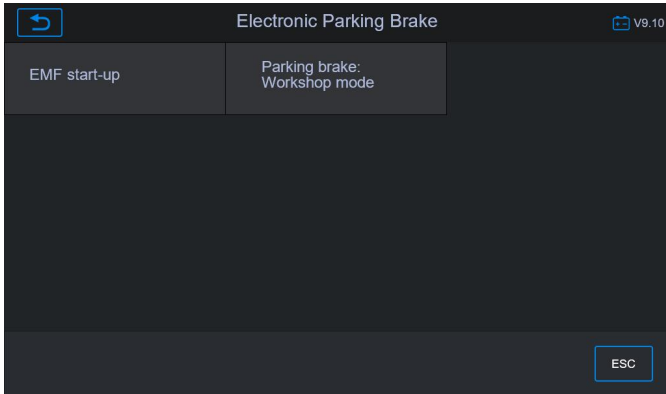

**Figure 5-9 Sample EPB Function List**

4. Follow the step-by-step on-screen instruction to complete the service.
5. Press **OK** button to exit.

### 5.3.2 EMF Star-up

This service function would start the parking brake, it must be conducted after the following repairs:

- Replacing an EMF control unit.
- Replacing the parking brake button.

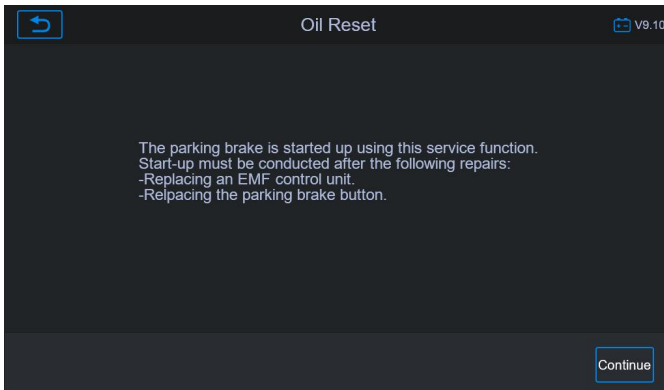

**Figure 5-10 Sample EMF Star-up Screen 1**

- 1) Tap **Continue** to proceed this service function or the **Back** button at the top left to exit.
- 2) Tap on the action taken to continue.

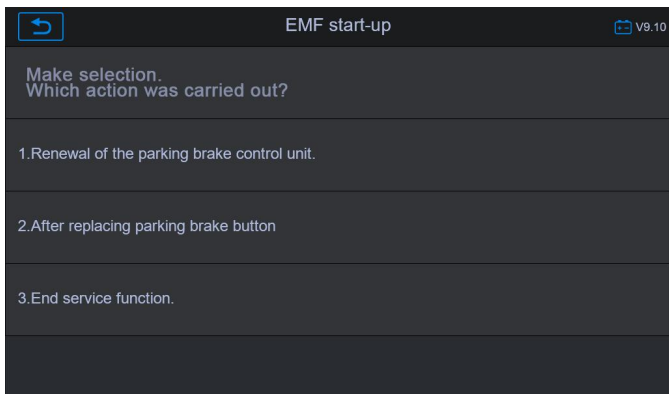

**Figure 5-11 Sample EMF Star-up Screen 2**

- 3) A screen will display to remind you that the fault memory of the parking brake control unit will be deleted, press **Continue** to proceed or the **Back** button to exit.

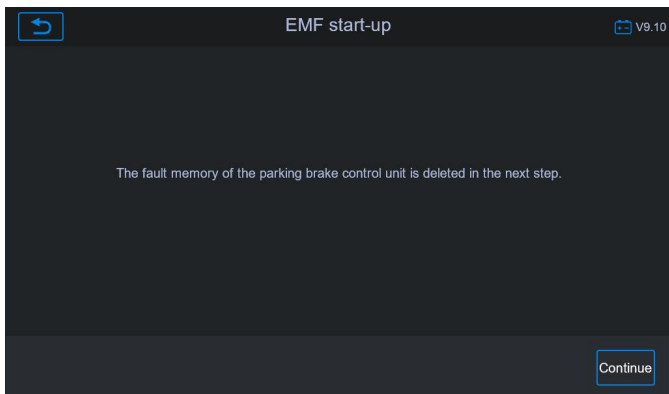

**Figure 5-12 Sample EMF Star-up Screen 3**

- 4) Follow the on-screen instructions to pull the parking brake button and wait for around 3 seconds until the parking brake is set. When the operation is successfully completed, a “Completed successfully” message will display on the screen. Press **OK** to exit.

### ***Parking Brake: Workshop Mode***

This service is used to activate and deactivate the so-called installation position for the Automatic Hold brake. In this mode, the parking brake is moved into the opened position and temporarily deactivated for personal protection.

The installation position must be activated for the following repairs:

- Replacement of brake pads.
- Replacement of a brake caliper.
- Replacement of an actuator.

Select **Parking Brake: Workshop Mode** and follow the on-screen instructions to perform a series of operations to start the brake pad after replacement.

When the operation is successfully completed, a “Completed successfully” message will appear on the screen. Press **OK** to exit.

## **5.4 Electronic Throttle Control**

---

Electronic Throttle Control system (ETC), relearns the throttle value control value while clear or replace the throttle value.

### **➤ To perform Throttle functions**

1. Tap the **Service** application button from the CR MAX Job Menu.
2. Tap **Throttle** icon and wait for the vehicle manufacturer screen. You can tap **VIN Scan** or the vehicle manufacturer to acquire vehicle VIN information and tap **Yes** to confirm. See *Vehicle Identification* on page 14 for detail.

3. Tap the needed service in the **Throttle** function list. The list may vary by vehicle.

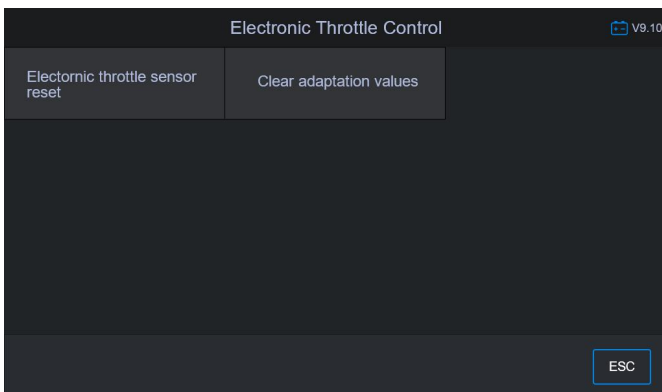

**Figure 5-13 Sample Electronic Throttle Control Screen 1**

4. Select the Electronic throttle sensor reset option and note the operator information on the screen. Make sure the vehicle is in the correct state. Continue to the next step to enter throttle learning. The system will adjust the throttle threshold.

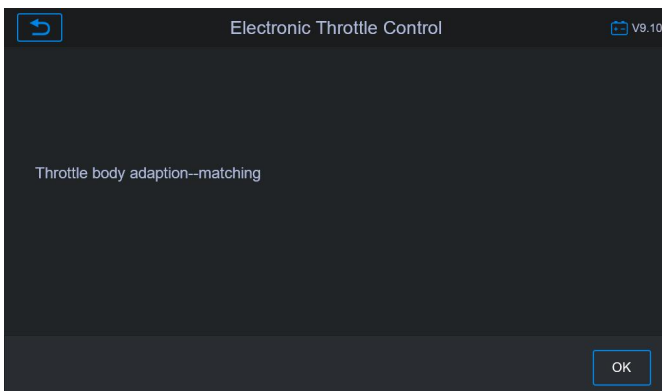

**Figure 5-14 Sample Electronic Throttle Control Screen 2**

- 5 If operation is successful, it appears information on the screen, Press OK to exit.

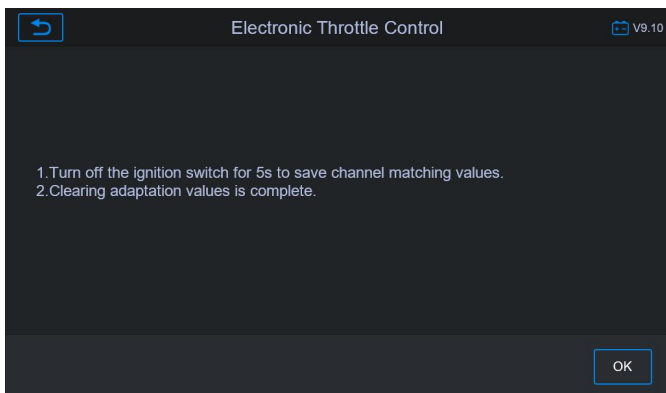

Figure 5-15 Sample Electronic Throttle Control Screen 3

## 5.5 Injector

---

When individual injectors are renewed, the injector control module requires the new configuration values for the injector to perform correctly. Write injector actual code or rewrite code in the ECU to the injector code of the corresponding cylinder so as to more accurately control or correct cylinder injection quantity. After the ECU or injector is replaced, injector code of each cylinder must be confirmed or re-coded so that the cylinder can better identify injectors to accurately control fuel injection.

### ➤ To perform Injector functions

1. Tap the **Service** application button from the CR MAX Job Menu.
2. Tap **Injector** icon and wait for the vehicle manufacturer screen. You can tap **VIN Scan** or the vehicle manufacturer to acquire vehicle VIN information and tap **Yes** to confirm. See *Vehicle Identification* on page 14 for detail.
3. Tap the needed service in the **Injector** function list. The list may vary by vehicle.

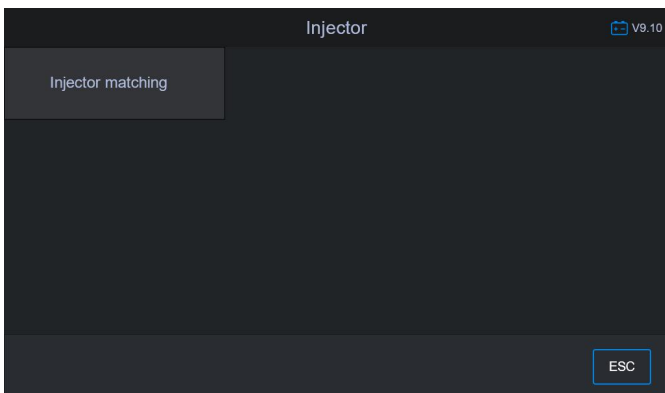

**Figure 5-16 Sample Injector Screen 1**

4. Select the fuel injector matching function. When replacing the fuel injector, it needs to match the fuel injector of the current vehicle system.

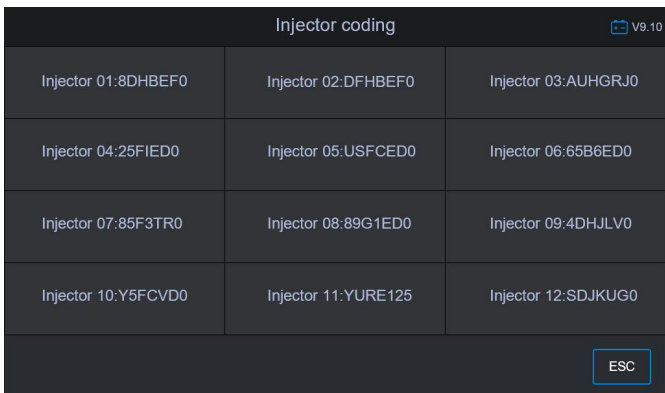

**Figure 5-17 Sample Injector Screen 2**

5. After the replacement of the injector is completed, select the number of the replaced injector and manually enter the code of the new replaced injector. Press OK.

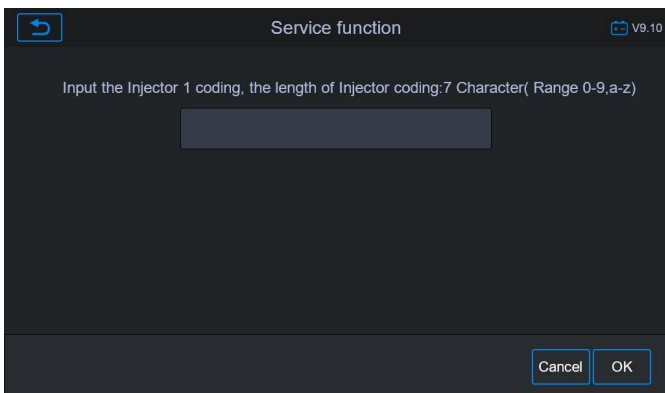

**Figure 5-18 Sample Injector Screen 3**

## **5.6 Steering Angle Sensor (SAS) Service**

---

Steering Angle Sensor Calibration permanently stores the current steering wheel position as the straight-ahead position in the steering angle sensor EEPROM. Therefore, the front wheels and the steering wheel must be set exactly to the straight-ahead position before calibration. In addition, the vehicle identification number is also read from the instrument cluster and stored permanently in the steering angle sensor EEPROM. On successful completion of calibration, the steering angle sensor fault memory is automatically cleared.

Calibration must be completed after the following operations:

- Steering wheel replacement
- Steering angle sensor replacement
- Any maintenance involving opening the connector hub from the steering angle sensor to the column
- Any maintenance or repair work on the steering linkage, steering gear or other related mechanism
- Wheel alignment or wheel track adjustment
- Accident repairs where damage to the steering angle sensor or



assembly, or any part of the steering system may have occurred

## NOTE

1. ICARSOFT accepts no responsibility for any accident or injury arising from servicing the SAS system. When interpreting DTCs retrieved from the vehicle, always follow the manufacturer's recommendation for repair.
2. All software screens shown in this manual are examples, actual test screens may vary for each vehicle being tested. Observe the menu titles and on-screen instructions to make correct option selections.
3. Before starting the procedure, make sure the vehicle has an ESC button. Look for the button on dash.

Using **Land Rover** as an example.

1. Tap the **Service** application button from the CR MAX Job Menu.
2. Tap **SAS** button and wait for the vehicle manufacturer screen. You can tap **VIN Scan** or the vehicle manufacturer to acquire vehicle VIN information and tap **Yes** to confirm. See *Vehicle Identification* on page 14 for detail.
3. Tap the needed service in the SAS function list. The list may vary by vehicle.

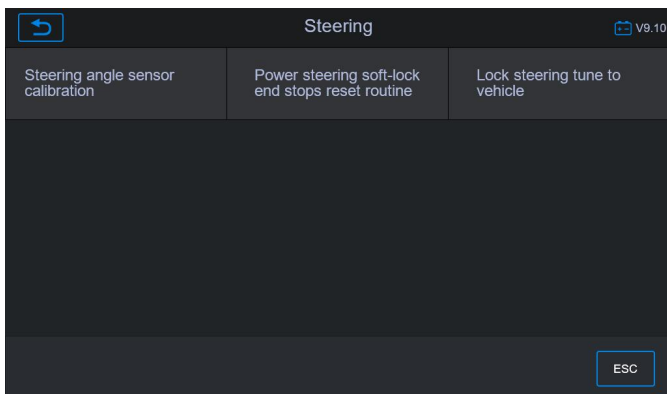
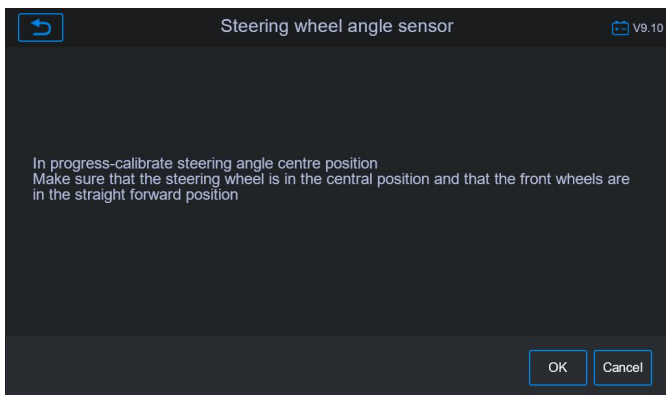

**Figure 5-19 Sample SAS Function Menu**

## 5.6.1 Steering Angle Sensor Calibration

This function allows users to perform steering angle sensor calibration and clear records. Available function options vary by vehicle.

- 1) Tap **Steering Angle Sensor Calibration** from the SAS function menu to enter the function screen.
- 2) Follow the on-screen instructions to set the ignition on/off as guided. The vehicle battery voltage signal should be in the range 12.5 – 13.5 volts to proceed with this service, otherwise the scan tablet will display a warning message.
- 3) Make sure the steering wheel is in the center position and the front wheels are straight. Then tap **OK** to proceed.



**Figure 5-20 Sample SAS Function Screen 1**

- 4) A confirmation message will display when the operation is complete. A message will display if operation could not be completed because of an existing issue. Repair problem after exiting the diagnostics application.

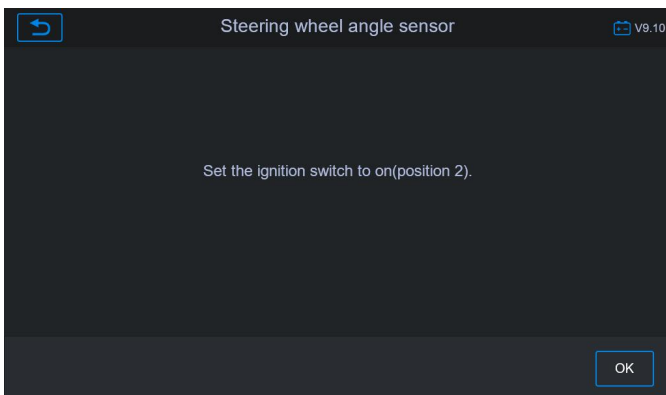

**Figure 5-21 Sample SAS Function Screen 2**

## 5.7 BMS

---

The BMS (Battery Management System) allows the scan tool to evaluate the battery charge state, monitor the close-circuit current, register the battery replacement, and activate the rest state of the vehicle.

---

### NOTE

1. This function is not supported by all vehicles. The screens shown in this section are examples.
  2. The sub functions and actual test screens of the BMS may vary by vehicle. Please follow the on-screen instructions to make the correct selection.
- 

The vehicle may use either a sealed lead-acid battery or an AGM (Absorbed Glass Mat) battery. Lead acid battery contains liquid sulphuric acid and can spill when overturned. AGM battery (known as VRLA battery, valve regulated lead acid) also contains sulphuric acid, but the acid is contained in glass mats between terminal plates.

It is recommended that the replacement aftermarket battery have the

same specifications, such as capacity and type, as the battery in the vehicle. If the original battery is replaced with a different type of battery (e.g. a lead-acid battery is replaced with an AGM battery) or a battery with a different capacity (mAh), the vehicle may require reprogramming the new battery type in

addition to performing the battery reset. Consult the vehicle manual for additional vehicle-specific information.

### 5.7.1 Register Battery Replacement

This option allows displaying the mileage reading of last battery replacement, registering the battery replacement after replacing a new battery and informing the power management system that a new battery has been fitted to the vehicle.

If the battery change is not registered, the power management system will not function properly, which may not provide the battery with enough charging power to operate the car and limit the functions of individual electrical equipment.

Using **BMW** as an example.

#### ➤ To display the battery history

1. Tap the **Service** application button from the CR MAX Job Menu.
2. Tap **BMS** button and wait for the vehicle manufacturer screen. Tap **VIN Scan** or the vehicle make to acquire vehicle VIN information and tap **Yes** to confirm. See *Vehicle Identification* on page 14 for detail.
3. Tap **Register Battery Replacement** in the EPB function list. The list may vary by vehicle.

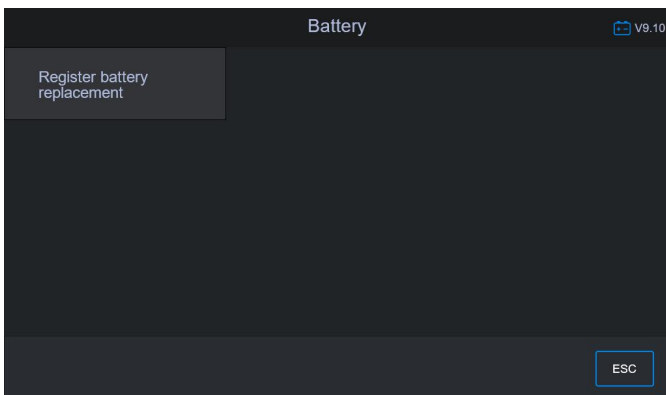

**Figure 5-22 Sample BMS Function List**

4. Tap on the service to perform. In this case, it is function 1.  
**Display kilometre reading at last battery change and one before last.** A notice screen displays.

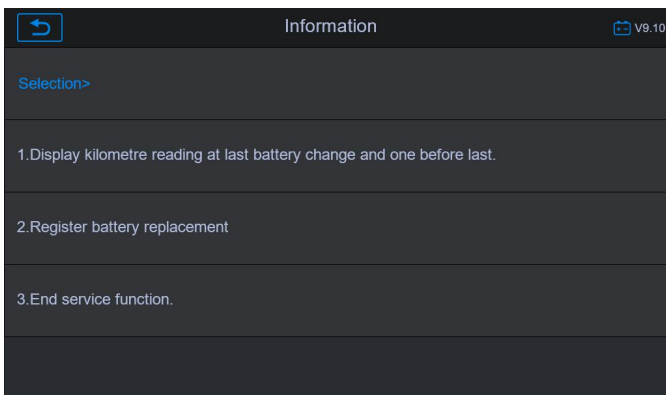

**Figure 5-23 Sample BMS Screen 1**

5. Read carefully the complete information and press **Continue**.

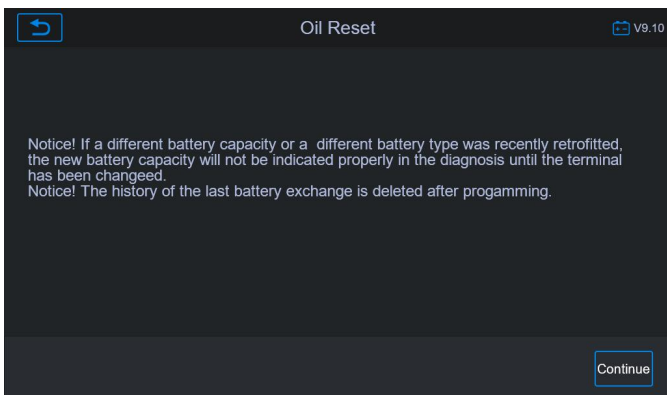

**Figure 5-24 Sample BMS Screen 2**

6. Check the battery capacity and the battery replacement information displayed.
7. Tap on function 1 to return to the selection screen or tap function 2 to end the service function.

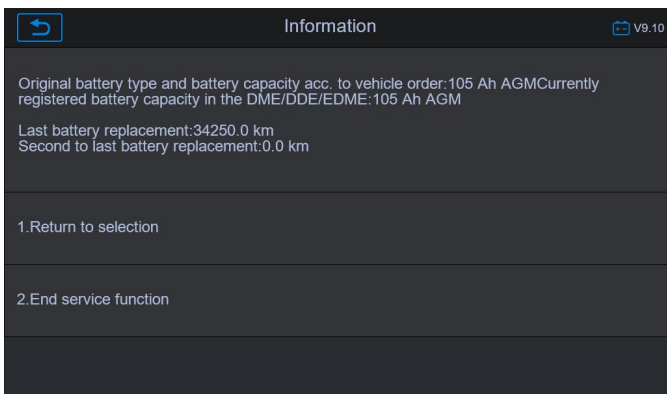

**Figure 5-26 Sample BMS Screen 3**

➤ **To register the battery replacement**

1. Tap on the corresponding service you want to carry out. In this case, it is function 2 **Register battery replacement**.

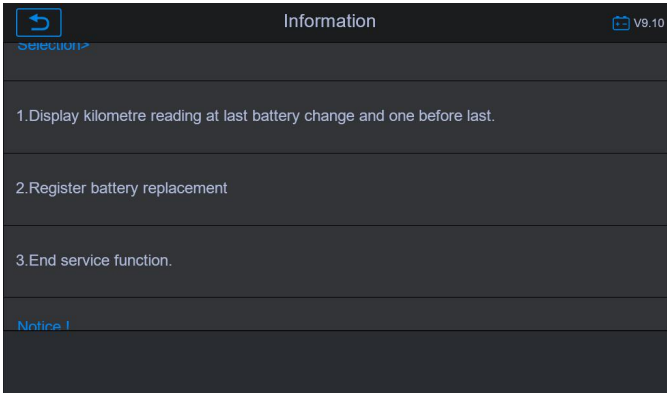

**Figure 5-25 Sample BMS Screen 4**

2. Read carefully the information on the screen and slide up/down to view all the functions listed.

Four functions are listed:

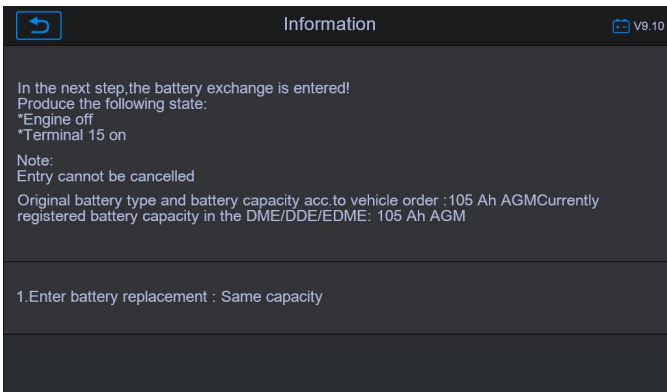

**Figure 5-27 Sample BMS Screen 5**

- 1) Enter battery replacement: Same capacity
- 2) Enter battery replacement: Different capacity
- 3) Enter battery replacement: Changing from the normal lead-acid battery (white housing) to AGM battery (black)

housing)

4) End service function.

Using function 1 as an example.

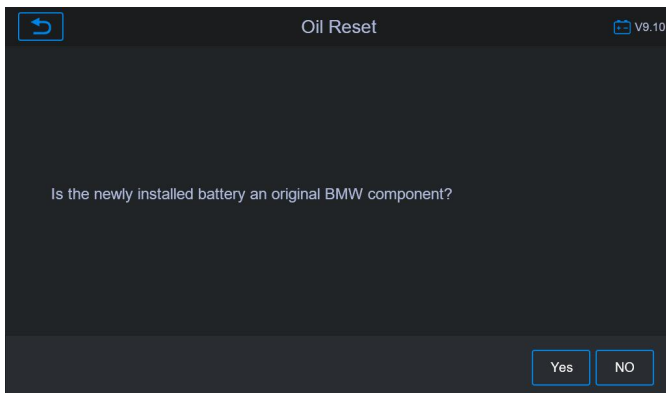

**Figure 5-28 Sample BMS Screen 6**

- 1) Read carefully the information on the screen and tap **Yes** to continue.
- 2) Follow the on-screen instructions to input the data matrix code labeled on the newly installed battery. Tap **OK** to continue.

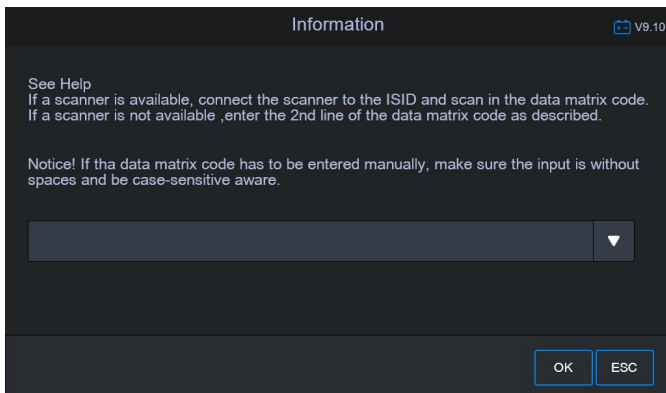

**Figure 5-30 Sample BMS Screen 7**



- 3) Tap **Continue** once the code was accepted and the exchange is complete.

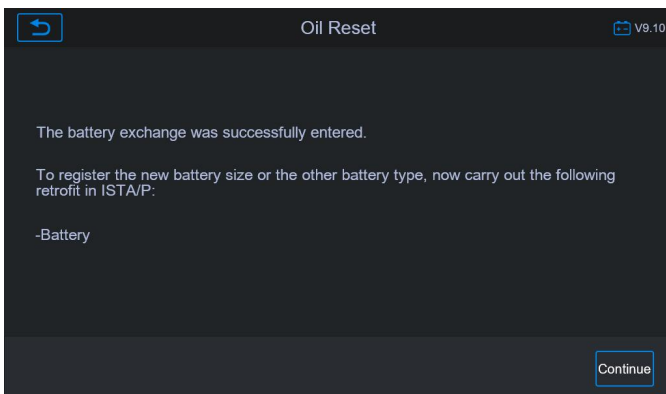

**Figure 5-31 Sample BMS Screen 8**

## **5.8 DPF Service**

---

The DPF function allows you to carry out numerous functions to the Diesel Particulate Filter system. The tool will manage DPF regeneration, DPF component replacement teach-in and DPF teach-in after replacing the engine control unit.

The ECM monitors driving style and selects a suitable time to employ regeneration. Cars driven primarily at idling speed and low load will attempt to regenerate earlier than cars driven with higher loads and at higher speed. For regeneration to occur, a prolonged high exhaust temperature must be obtained.

In the event that the vehicle has been driven in such a way that regeneration is not possible, a diagnostic trouble code will be registered, DPF light and "Check Engine" indicator will display. A service regeneration can be performed using this tool.

Before carrying out a forced DPF regeneration, check the following items:

- The fuel light is not on.

- No DPF-relevant faults are stored in system.
- The vehicle has the correct spec engine oil.
- The oil for diesel is not contaminated.

---

**! IMPORTANT**

Before diagnosing a vehicle and attempting to perform an emergency regeneration, it is important to obtain a full diagnostic log and read out relevant measured value blocks.

---

**🔄 NOTE**

1. The DPF will not regenerate if the engine management light is on, or there is a faulty EGR valve.

2. The ECU must be re-adapted when replacing the DPF and adding the fuel additive Eolys.

3. If the vehicle needs to be driven in order to perform a DPF service, ALWAYS have a second person help you. One person should drive the vehicle while the other person observes the screen on the Tool. Trying to drive and observe the Scan Tool at the same time is dangerous, and could cause a serious traffic accident.

---

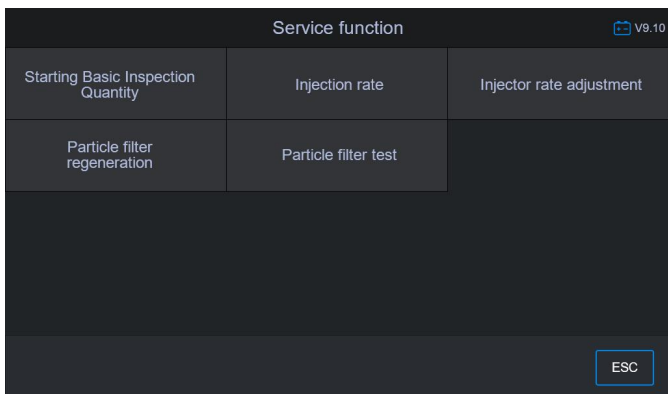

**Figure 5-32 Sample DPF Service Function Menu**

## 5.8.1 Starting Basic Inspection Quantity

This function enables you to start fuel delivery matching.

1. Tap **Starting Basic Inspection Quantity** from the service functions menu to enter the service screen.
2. The tool communicates with the vehicle and reads the fault codes memory. Follow the on-screen instructions to finish this procedure.
3. The tool will display a function list menu as below. Press the corresponding number button to perform the desired function.



**Figure 5-33 Sample Starting Basic Inspection Quantity**

### **[1] Enter New Value for Adjustment**

From the **Starting Basic Inspection Quantity** menu, tap **[1]** and the screen displays as below.

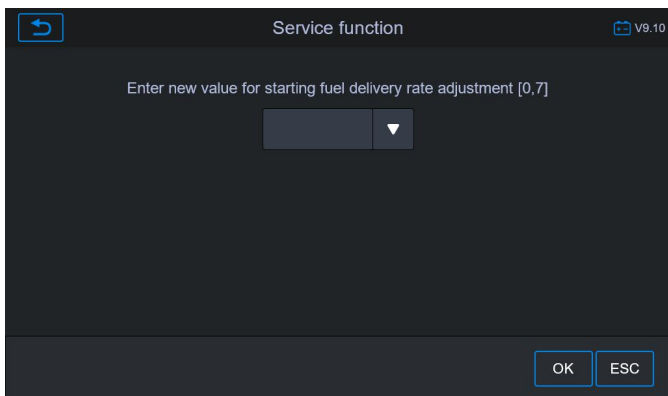

**Figure 5-34 Sample Enter New Value Screen**

After entering the value, tap **OK** to save the value to the tool. Tap **ESC** to exit the operation.

---

**NOTE**

The data you input should be in the range given. If the input data is out of range, the tool will display a warning message "Permissible adjustment range exceeded."

---

**[2] Reset Adjustment to 0**

Once the **[2]** is tapped, the tool will automatically reset the value to zero.

**[3]/[4] Store Data and Exit**

When the fuel delivery rate adjustment is completed, tap **[3]** to store the new value in the control units; or select **[4]** and **OK** to retain the old value.

## 5.8.2 Injection Rate

This function is used to adjust the injection volume.

- 1) Tap **Injection Rate** from the service functions menu to enter the service screen.
- 2) The tool communicates with the vehicle and reads the fault

codes memory. Follow the on-screen instructions to finish this procedure.

- 3) Then the tool will display as below. Press the corresponding number button to perform the desired function.

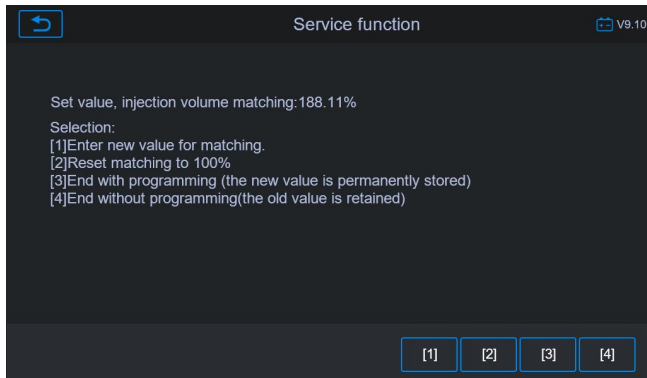

**Figure 5-35 Sample Injection Rate Screen**

### **[1] Enter New Value for Adjustment**

From the **Injection Rate** menu, tap **[1]** and the screen displays as below.

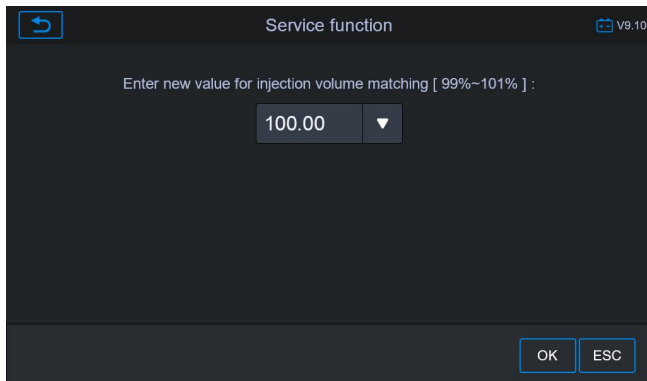

**Figure 5-36 Sample Enter Value Screen**

---

**NOTE**

The data you input should be in the defined range. If the input data is out of range, the tool will display a warning message “Permissible adjustment range exceeded.”

---

**[2] Reset Adjustment to 100%**

Once the **[2]** is pressed, the tool will automatically reset the value to 100%.

**[3]/[4] Store Data and Exit**

When the injection volume adjustment is completed, select **[3]** and **OK** to store the new value in the control units; or select **[4]** and **OK** to retain the old value.

### 5.8.3 Injector Rate Adjustment

This function is used to adjust the injector rate for individual cylinders.

1. Tap **Injection rate adjustment** from the service functions menu.
2. The tool communicates with the vehicle and reads the fault codes memory. Follow the on-screen instructions to enter the service function.
3. Tap the corresponding number button to enter new value for each cylinder.
4. Follow the on-screen instructions to tap on the corresponding number **[1] [2] [3] [4]** to enter the new value for the cylinder, restore the old value, and exit after finish the function.

### 5.8.4 Particle Filter Regeneration

This function is used to perform the particle filter regeneration.

1. Tap **Particle filter regeneration** from the service functions menu.
2. The tool communicates with the vehicle and reads the fault codes memory. Follow the on-screen instructions to check the prerequisites before particle filter regeneration, such as the fuel,

the time and driving style.

3. If every prerequisite is met, the tool will ask for confirmation to proceed as below. Tap **Request** to begin a regeneration or **End** to end the service function and exit.

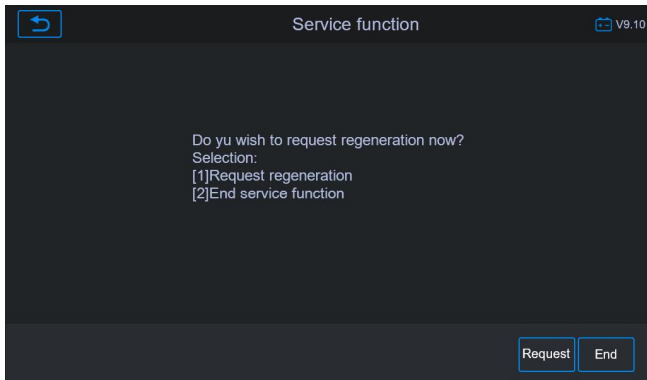

**Figure 5-37 Sample Regeneration Confirmation Screen**

4. Follow the on-screen instructions to perform the particle filter regeneration and tap **OK**.

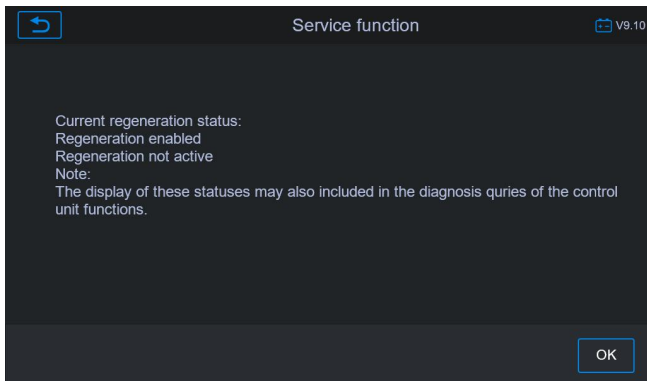

**Figure 5-38 Sample Regeneration Status Screen**

5. When the particle filter regeneration is complete, the tool will ask for a confirmation to exit. Tap **Repeat** to re-check the status or

tap **End** to exit.

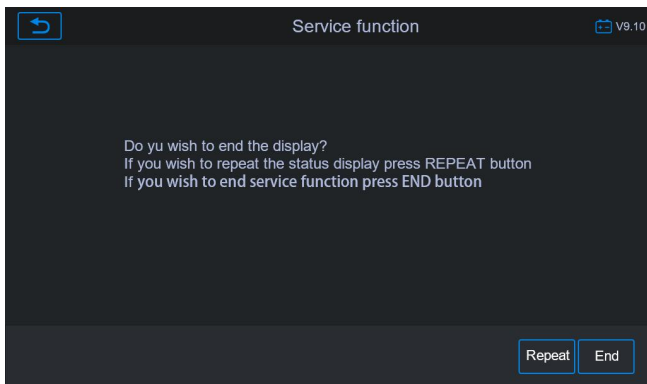

**Figure 5-39 Sample Repeat Screen**

---

**NOTE**

In the case of a particle filter heavily loaded with soot, it can occur that the regeneration request is blocked again after a short time or is not released. In this case, it is required to regenerate the particle filter by driving the vehicle for approximately 30 minutes at a constant speed. Subsequently, the service function "Particle filter regeneration" must be run again.

During the regeneration phase and with the engine running, it can also occur that the display message changes from "Regeneration active" to "Regeneration not active". This behavior can be seen exclusively with the vehicle stationary.

---

### **5.8.5 Particle Filter Test**

It is advisable to carry out a series of particle filter tests as a result of constant DPF regeneration, such as checking oil level, oil change interval for diesel contamination, swirl flaps, backpressure sensors and particle filter soot remains.

1. Tap **Particle filter test** from the service functions menu.
2. The tool communicates with the vehicle and reads the fault codes memory. If there is no relevant fault code stored in DDE,



the screen displays a message stating this. Select **Cancel** to exit this function.

3. If there are DPF-related codes stored in DDE, the screen displays as below. Select **OK** to continue or **Cancel** to exit this function.

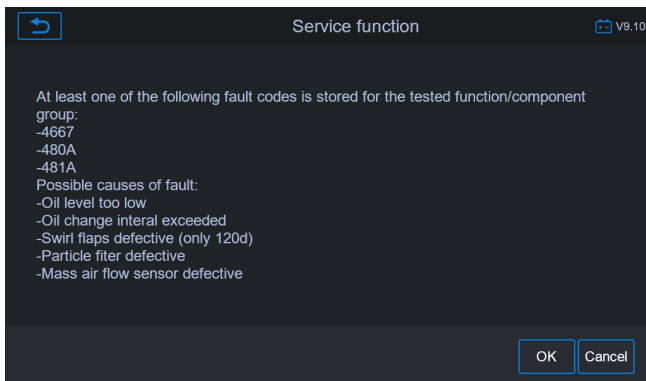

**Figure 5-40 Sample Codes Screen**

4. The tool displays a list of particle filter test. Select the corresponding button to perform the desired test **[1]** **[2]** **[3]** **[4]** **[5]**.

**[1]** Visual Inspection of Engine Oil

**[2]** Visual Inspection of Particulate Filter

**[3]** Function Check or Swirl Flaps

**[4]** Exhaust Backpressure Test

**[5]** Actual/Target Value Check-Mass Air Flow Sensor

## **5.9 AFS Head Lamp**

---

AFS Head Lamp reset means that the adaptive front lighting system can be rotated to either side, pressing the button means they stay pointing straight forward, and don't turn anymore when turning the

steering wheel.

Using **VW** as an example:

➤ **To perform AFS Head Lamp functions**

- 1) Tap the **Service** application button from the CR MAX Job Menu.
- 2) Tap **AFS Head Lamp** button and wait for the vehicle manufacturer screen. You can tap **VIN Scan** or the vehicle manufacturer to acquire vehicle VIN information and tap **Yes** to confirm. See *Vehicle Identification* on page 14 for detail.
- 3) Tap the needed service in the **AFS Head Lamp** function list. The list may vary by vehicle.
- 4) At this time, you will get the prompt information that the headlights need to be replaced under the following conditions and the prerequisites for headlight replacement. Press ok to continue.

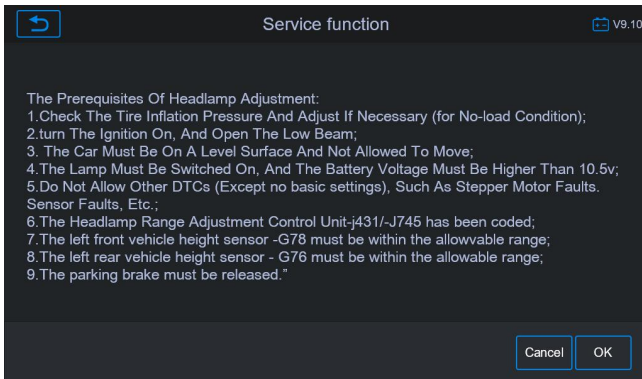

**Figure 5-41 Sample AFS Head Lamp Screen1**

- 5) Adjust the headlights according to the screen operation.

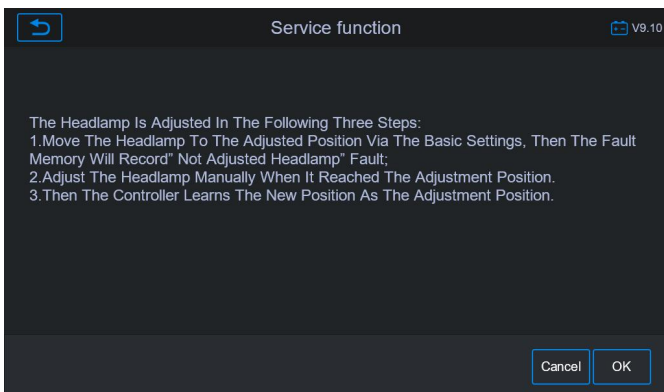

**Figure 5-42 Sample AFS Head Lamp Screen2**

- 6) After adjusting the headlights, a prompt message will appear on the screen. Whether the headlights are adjusted well, choose yes or no. After the adjustment, learn the position of the headlight adjustment, and follow the screen operation.

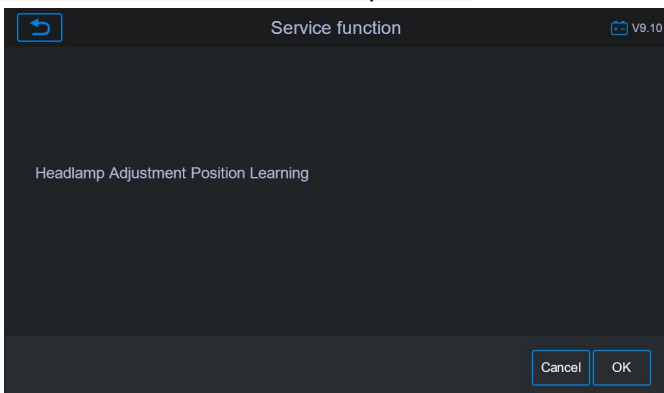

**Figure 5-43 Sample AFS Head Lamp Screen3**

- 7) Until the screen prompts the application to complete, press OK to exit.

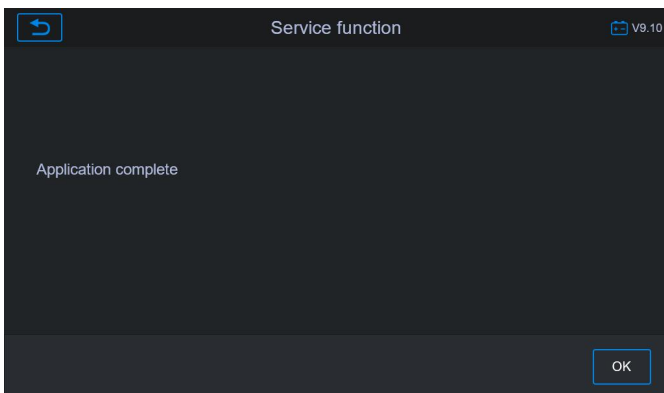

**Figure 5-44 Sample AFS Head Lamp Screen4**

## **5.10 Air Suspension**

---

Air Suspension: Try reset electronic suspension air ride with the message system close all doors flip through message system go to suspension reset or off.

Using **Benz** as an example:

### **To perform Air Suspension functions**

- 1) Tap the **Service** application button from the CR MAX Job Menu.
- 2) Tap **Air Suspension** icon and wait for the vehicle manufacturer screen. You can tap **VIN Scan** or the vehicle manufacturer to acquire vehicle VIN information and tap **Yes** to confirm. See *Vehicle Identification* on page 14 for detail.
- 3) Tap the needed service in the **Air Suspension** function list. The list may vary by vehicle.

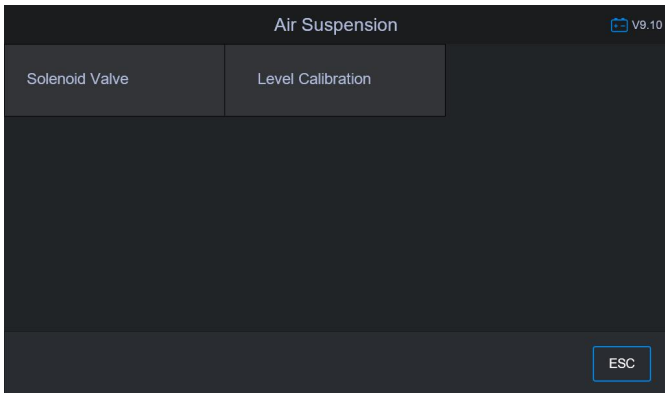

**Figure 5-45 Sample Air Suspension Screen1**

- 4) Select Level Calibration as an example, follow the screen requirements step by step, pay attention to the screen prompts.

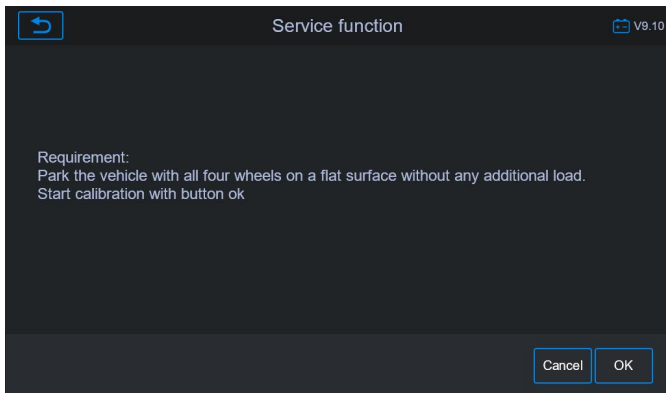

**Figure 5-46 Sample Air Suspension Screen2**

- 5) After completion, a successful message will appear on the screen.

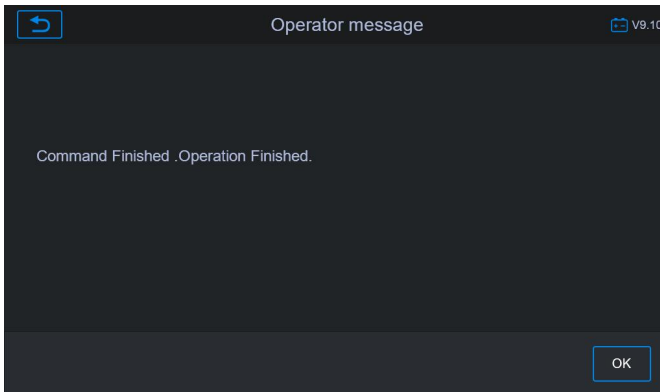
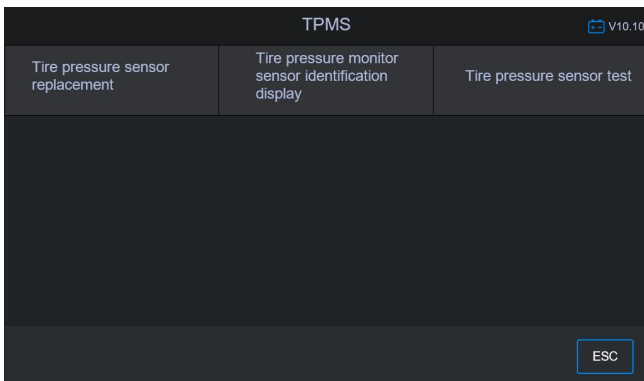

**Figure 5-47 Sample Air Suspension Screen3**

## 5.11 TPMS programming service

---

The TPMS service function include displaying sensor IDs from the vehicle's ECU, inputting TPMS sensor replacement IDs and testing sensors.



**Figure 5-48 Sample TPMS Function Menu**

Select tire pressure sensor replacement (Front left wheel sensor) as an example.

---

**NOTE**

This function will require the sensor ID be inputted on the screen.

The sensor IDs can be read directly from the sensor or by using a sensor activation tool that can read the ID.

Once the IDs have been entered, the vehicle may have to be driven at a certain speed for a certain time to complete procedure. Follow the instructions displays.

---

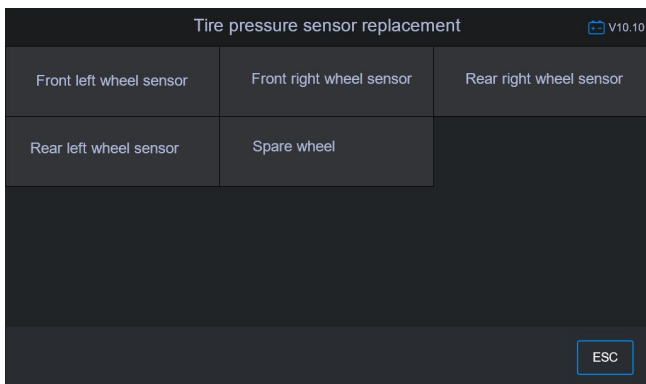

**Figure 5-49 Sample Tire Pressure Sensor Replacement Screen**

- 1) Tap **Front left wheel sensor** on the tire pressure sensor replacement menu.
- 2) Enter the 8 digit sensor identification as required. Press **OK**.

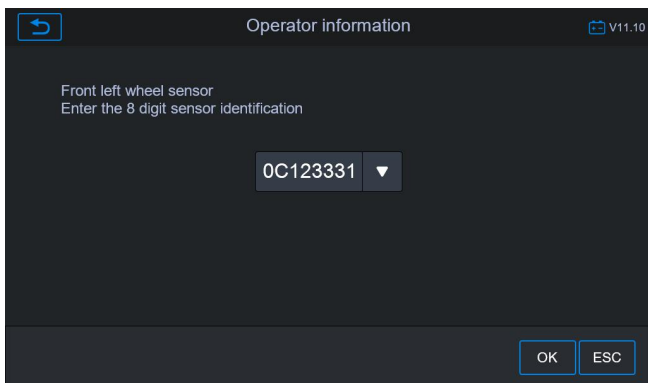

**Figure 5-50 Sample Sensor ID Input Screen**

- 3) Continue to select tire position and enter sensor IDs. A message will display when the entered IDs have been registered to the vehicle.

---

**NOTE**

The vehicle must remain stationary for at least 15 minutes with the ignition off, this will place the sensors into sleep mode. The vehicle must be driven for at least 15 minutes at a speed higher than 20 kph to ensure the module has learned the sensor identifications and positions.

---

For other services, please follow the on-screen instructions to operate.

On completion of the drive cycle, carry out the tire pressure monitor system test application.

---

## 5.12 Gearbox Reset

After the gearbox is disassembled or repaired, it will cause shift delay or shock problems. At this time, this function needs to be executed to make the gearbox automatically compensate according to the driving conditions in order to achieve a more comfortable and more ideal shift quality.



Using **Benz** as an example:

### To perform Gearbox Reset functions

- 1) Tap the **Service** application button from the CR MAX Job Menu.
- 2) Tap **Gearbox Reset** icon and wait for the vehicle manufacturer screen. You can tap **VIN Scan** or the vehicle manufacturer to acquire vehicle VIN information and tap **Yes** to confirm. See *Vehicle Identification* on page 14 for detail.
- 3) Tap the needed service in the **Gearbox Reset** function list. The list may vary by vehicle.

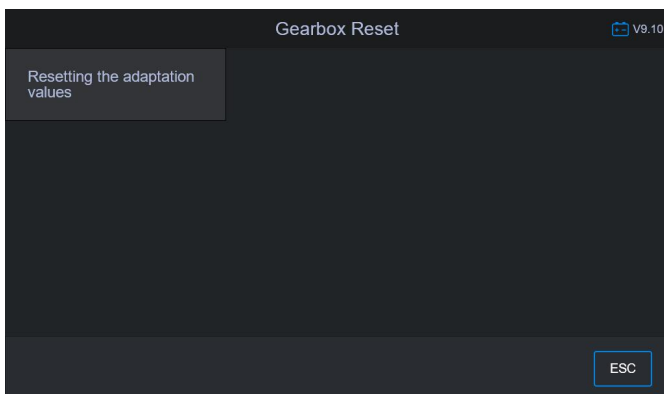

**Figure 5-51 Sample Gearbox Reset Screen1**

- 4) Follow the on-screen instructions step by step, carefully read the operation prompt information and determine whether to reset the fitness value, if so, wait for the device to establish communication with the vehicle. And prompt success information.

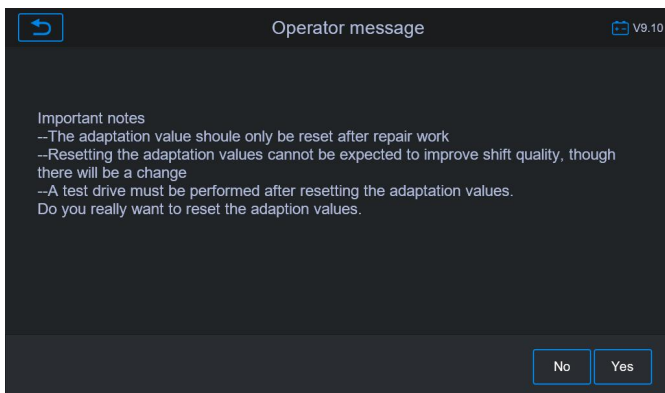

**Figure 5-52 Sample Gearbox Reset Screen2**

## 5.13 Air conditioning service

---

After the replacement of Air conditioning, blower pumps, etc. in the air conditioner, the air conditioning system may not work properly. In this case, you need to perform this function to actuate the air conditioner for a period of time to match the original refrigerants such as the replaced refrigerant and blower pump.

Using **Benz** as an example:

### To perform Air conditioning service functions

- 1) Tap the **Service** application button from the CR MAX Job Menu.
- 2) Tap **Air conditioning service** icon and wait for the vehicle manufacturer screen. You can tap **VIN Scan** or the vehicle manufacturer to acquire vehicle VIN information and tap **Yes** to confirm. See *Vehicle Identification* on page 14 for detail.
- 3) Tap the needed service in the **Gearbox Reset** function list. The list may vary by vehicle.

Injector coding <span style="float: right;">v9.10</span>		
PTC Heater Booster Operating Only In Made "AC ON"	Refrigerant Compressor	Radiator Shutters
Belt Pulley of refrigerant compressor	Correction value for windshield fogging measured by moisture and temperature sensor	A9u1(Refrigerant compressor magnetic clutch)
PTC Heater Booster	B82(Vehicle Interior Humidity and temperature sensor)	N70b1(Interior Temperature sensor with integrated fan)
Breaking-in of refrigerant compressor	Normalization of actuator motors	Teach-in of actuator motors
<span style="border: 1px solid black; padding: 2px 10px;">ESC</span>		

**Figure 5-53 Sample Air conditioning service Screen**

## 5.14 Air Filter Self-learning process after replacing the air filter

The engine is a very precise machine part, and even the smallest impurities will cause the wear of the engine. Therefore, the air must be filtered by the air cleaner before entering the cylinder. Therefore, disassembly, maintenance or replacement of the air filter will cause some particulate impurities in the air to enter the car parts. At this time, the air filter learning and matching functions need to be performed to make the air filter work normally.

Air Filter Self-learning process after replacing the air filter <span style="float: right;">v9.10</span>		
Teaching in the diesel particulate Filter after replacing the engine control unit	Teach-in process after replacement of component B18/15(Temperature sensor upstream of SCR catalytic) unit	Teach-in process after replacement of component B28/8(DPF differential pressure sensor)pressure sensor)
Teach-in process after replacement of component Diesel particulate filter	Teach-in process after replacement of component G3/2(Oxygen sensor upstream of KAT)	Regeneration of diesel particulate filter when driving
Teach-in process after replacement of component Y129(AdBlue(R) Metering Valve)	Teach-in process after replacement of component Y27/9(EGR positioner)	Teach-in process after replacement of component NOx sensor upstream of SCR catalytic converter
Teach-in process after replacement of component NOx sensor downstream of SCR catalytic converter	Teach-in process after replacement of component Oxidation Catalytic Converter	
<span style="border: 1px solid black; padding: 2px 10px;">ESC</span>		

**Figure 5-54 Sample Air Filter Screen**

## 5.15 Fuel Pump activation function

---

After the fuel pump is disassembled, repaired or replaced, it may cause the fuel pump to be unable to continue to provide fuel to the fuel injection nozzle. At this time, the function needs to be executed to activate the replaced fuel pump so that the car can start to inject fuel normally and make the engine achieve the ideal Running status .

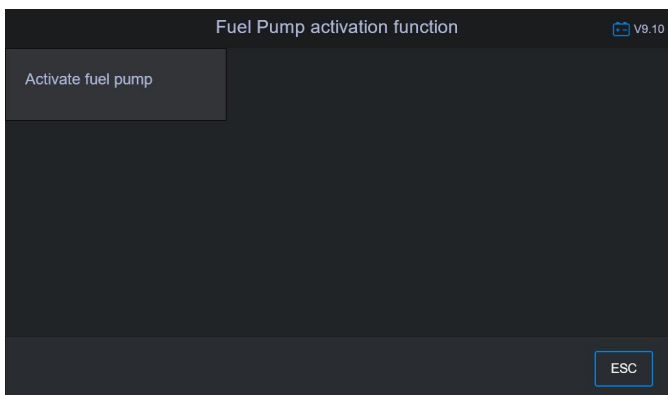
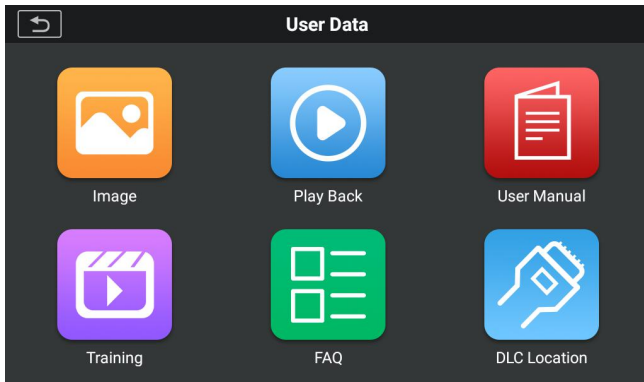

**Figure 5-55 Sample Fuel Pump activation Screen**

# 6 User Data

The **Data Manager** application is used to store, print, and review the saved files. Most operations are controlled through the toolbar.

Selecting the Data Manager application opens the file system menu. Different file types are sorted separately under different options, there are six types of information files to be viewed or played back.



**Figure 6-1 Sample Data Manager Main Screen**

## 6.1 Operations

---

Data Manager Operations are based on toolbar controls. Details are explained in the following sections.

### 6.1.1 Image Files

The Image section contains all captured screenshot images.

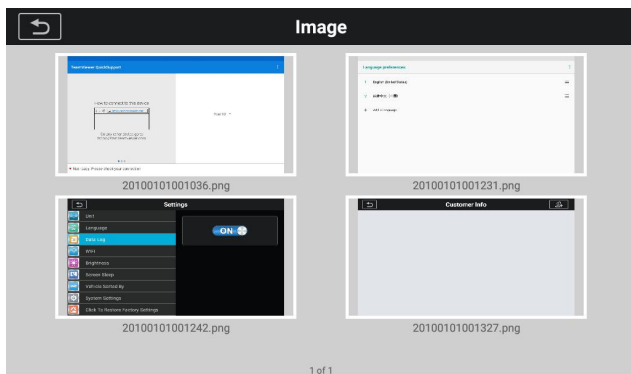

**Figure 6-2 Sample Image Screen**

## 6.1.2 Play Back

The playback section allows you to view diagnostic data, real-time data, and fault codes on the system.

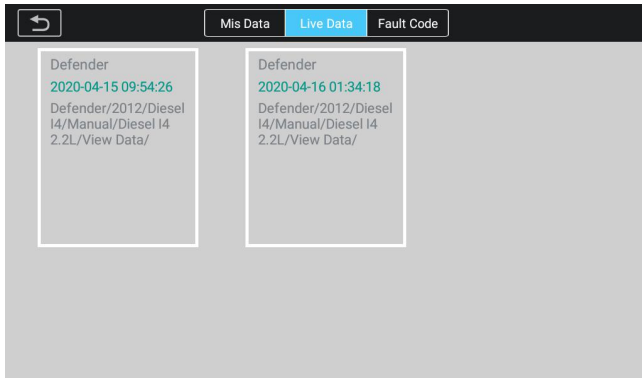

## 6.1.3 User Manual

The user manual section stores and displays the user manual, and saves the data PDF file to view the user manual of this device. In this section, use the standard adobe reader application to view and edit the file. Please refer to the relevant adobe reader manual for

instructions.

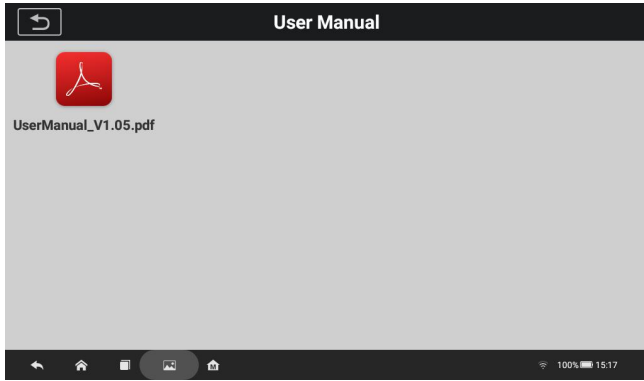

**Figure 6-1 Sample User Manual Screen**

### 6.1.4 Training

The training section provides videos of operating applications to facilitate customers to quickly understand the operating functions of CR MAX..

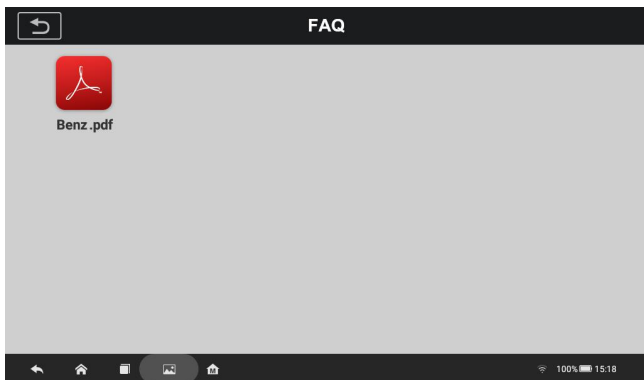

**Figure 6-2 Sample Training Screen**

## 6.1.5 FAQ

The FAQ section provides comprehensive answers to the most frequently asked questions of various vehicle models.

The FAQ option provides the user's Q & a documentation, in PDF format, to view the user's FAQs. In this section, use the standard adobe reader application to view and edit files. For instructions, refer to the relevant adobe reader manual.

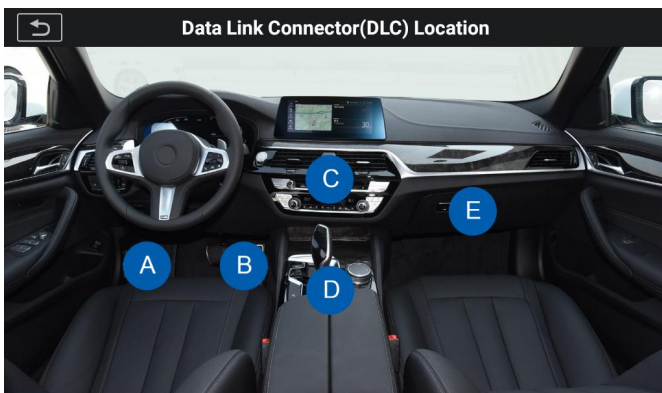

**Figure 6-2 Sample Function List Screen**

## 6.1.6 Data Link Connector(DLC) Location

This function is to provide the location of the data link connector(DLC), represented by A,B,C,D,E respectively.



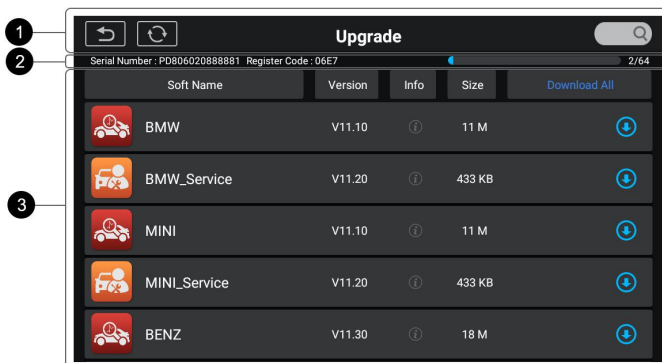

**Figure 6-2 Sample DLC Location Screen**

## 7 Upgrade

The Update application allows you to download the latest released software. The updates can improve the CR MAX applications' capabilities, typically by adding new tests, new models, or enhanced applications.

The tablet automatically searches for available updates for the CR MAX software when it is connected to the internet. Any updates that are found can be downloaded and installed on the device. This section describes installing an update to the CR MAX System. If the Notification Center is enabled in the Settings application, a notification message will display when an update is available. (See *Notification Center* page 85 for details).



**Figure 7-1 Sample Update Screen – for CR MAX**

### ① Navigation and Controls

- Home Button – returns to the CR MAX Job Menu.
- Update All – downloads all available updates.
- Search Bar – search specific update item by inputting the file name,  
➤ for example: a vehicle make.

### ② Status Bar

- Left Side – displays the CR MAX device model information and serial number.
- Right Side – displays an update progress bar indicating the completion status.

### ③ Main Section

- Left Column –displays the diagnostic function icon and service function icon and the name of the software;
- Middle Column –displays a summary of software changes, including software version, detailed information, and size. Tap the ⓘ button to open the information screen to view detailed information. Tap the ⊗ button to turn it off.

- Right Column – controls software update. According to the status of the software download, a different titled button displays.
  - a) Tap the download icon to update the item you want to update.
  - b) Tap **Pause** to suspend the software update.
  - c) Tap **Continue** to resume updating the software.

➤ **To update the diagnostic software and service software**

1. Make sure the Display Tablet is connected to a power source with stable access to the internet.
2. Tap the **Upgrade** application button from the CR MAX Job Menu; or tap the update notification message when received; or tap the **Upgrade** icon on Vehicle Menu in Diagnostics application. The Update application screen displays.
3. Check all available updates:
  - If you decide to update all items of the software, please tap the "Download All" button.
  - If you only want to update one or some of the item(s), tap the **Update** button on the right column of the specific item(s).
4. Tap the **Pause** button to suspend the update. Tap **Continue** to resume the update. The update will resume from the point at which it was paused.
5. The firmware will be installed automatically once its download has completed. The previous version will be replaced.







# 8 Shop Information

The Shop Manager application manages the workshop information including customer information records and test vehicle history records. There are three main functions available:

- **Vehicle History**
- **Workshop Information**
- **Customer Information**

The operations of these functions of the Shop Manager application are controlled by the toolbar buttons, which are listed and described in the table below:

**Table 8-1 Top Toolbar Buttons in Shop Manager**

Button	Name	Description
	<b>Back</b>	Cancel the current operation and return to the previous screen.
	<b>Add Account</b>	Tap this button to create a new customer account file.
	<b>Save</b>	Complete editing and save the file.
	<b>Delete</b>	Tap this button to delete the selected customer information and vehicle record.
	<b>Modify and save</b> <small>edit</small>	Tap this button to save the modified customer information and vehicle information.
	<b>Add Customer Notes</b>	Tap this button to open a note form. New customer notes can be added.

## 8.1 Workshop Info

---



2. Select **Customer Info**.
3. Tap the **Add Account** button. An empty information form displays, tap each field to input the appropriate information.

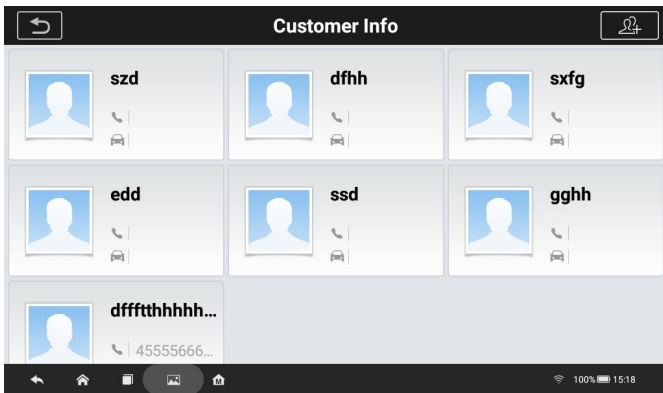

**Figure 8-2 Sample Customer Info Sheet**

---

**NOTE**

Required fields are noted.

---

4. If a customer adds or changes vehicles, tap **Add New Vehicle Information**, and input the vehicle information. Tap the (X) button to cancel.
5. Tap the **Save** button in the upper right corner to save the updated workshop information table, or click the **back** button in the upper left corner to exit without saving.

➤ **To edit a customer account**

1. Tap the **Shop Info** application on the CR MAX Job Menu.
2. Select **Customer Manager**.
3. Select a customer account by tapping the corresponding name card. A Customer Information sheet displays.
4. Tap on the input field that needs to be altered or supplemented, and enter updated information.

5. Tap the **Modify edit and save** button on the top toolbar to save the updated information, or tap the **Back** button on the top toolbar to exit without saving.

➤ **To delete a customer account**

1. Tap the **Shop Info** application on the CR MAX Job Menu.
2. Select **Customer Manager**.
3. Select a customer account by tapping the corresponding name card. A Customer Information sheet displays.
4. Tap the **Delete** button on the top toolbar. A confirmation message displays.
5. Tap **Yes** to confirm the command, and the account is deleted. Tap **Cancel** to cancel the request.

## 8.2.1 Customer Notes

Use the Customer Notes function to add customer text record.

➤ **To access Customer Notes**

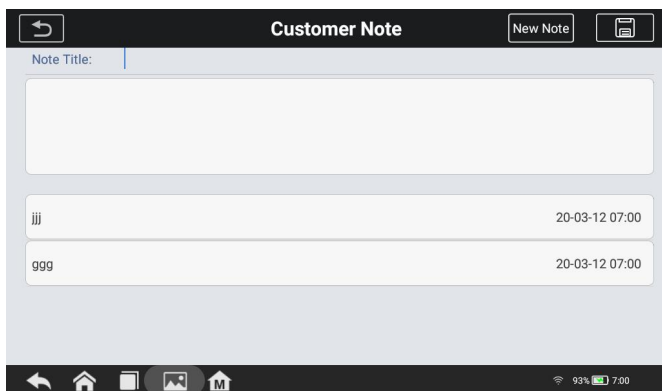

1. Tap the **Shop Info** application on the CR MAX Job Menu.
2. Select **Customer Manager** or **Vehicle History**.
3. Select a customer account by tapping the corresponding name card. A Customer Information sheet displays (if **Customer Manager** is selected). Or, select a vehicle history record item to open the Historical Test record sheet (if **Vehicle History** is selected).
4. Tap the **Add Customer Notes** button on the top bar. Now the **Customer Notes** interface is displayed.



**Figure 8-3 Sample Customer Notes Screen**

- 1) **Functional Buttons** – navigates and performs various actions.
- 2) **Main Section** – displays the note list on the left column and the detail information of the selected note displays on the right column.

**Table 6-2 Function Buttons in History Notes**

Button	Name	Description
	<b>Back</b>	Cancel the current operation and return to the previous screen.
	<b>New Note</b>	Tap this button to quickly clear the information and create a new record
	<b>Save</b>	Saves notes.

➤ **To add a note in Customer Notes**

1. Access Customer Notes. An edit window displays.
2. Tap on the Title bar to input a note title.
3. Tap on the blank space below to edit a text note or remark.
4. Select the new note button at the top to clear the current



note and re-enter the new note.

5. Tap **Save** to save the note; tap **Back** button to exit without saving.
6. Select historical notes and tap **X** to delete.

## 8.3 Vehicle History

This function stores test vehicle history records, including vehicle information and the retrieved DTCs from previous diagnostic sessions. All information is displayed in summarized details. Tap on a record to resume a diagnostic session on a “stored vehicle”.

Vehicle history	
2020.03	4 Records
Up to 2007 Land Rover Freelander 2020-04-08 10:33:57 Land Rover/Up to 2007/Freelan... DTC Count:0 VIN	Up to 2007 Land Rover Freelander 2020-04-08 10:33:57 Land Rover/Up to 2007/Freelan... DTC Count:0 VIN
Up to 2007 Land Rover Freelander 2020-04-08 10:33:57 Land Rover/Up to 2007/Freelan... DTC Count:0 VIN	Up to 2007 Land Rover Freelander 2020-04-08 10:33:57 Land Rover/Up to 2007/Freelan... DTC Count:0 VIN
2020.02	24 Records
2020.01	4 Records
2019.12	5 Records
2019.11	27 Records
2019.10	36 Records
2019.09	8 Records

**Figure 8-4 Sample Vehicle History Screen**

- **To activate a test session for the recorded vehicle**
1. Tap the **Shop Info** application on the CR MAX Job Menu.
  2. Select **Vehicle History**
  3. Or, tap the vehicle record thumbnail to view record.
  4. A Historical Test record sheet displays, check the recorded information of the recorded test vehicle, and tap the Diagnostics button on the upper right corner.
  5. The vehicle's Diagnostics screen displays a new diagnostic

session.

### 8.3.1 Historical Test Record

The Historical Test record sheet is a detailed data form that includes general vehicle information such as vehicle year, make and mode. The form also includes retrieved DTC from previous test and all information manually inputted by the technician.

➤ **To edit the Historical Test record sheet**

1. Tap the **Shop Info** application on the CR MAX Job Menu.
2. Select **Vehicle History**.
3. Select the specific vehicle history record thumbnail from the main section. The Historical Test record sheet displays.
4. Tap the **Edit** button to start editing.
5. Tap on each item to input the corresponding information or add relevant files or images.

---

 **NOTE**

The vehicle VIN number, or license and the customer information account are correlated by default.

---

6. Tap **Add to Customer** to supplement a Historical Test record sheet to an existing customer account, or add a new associated account with the test vehicle record. See *Customer Manager* on page 73 for more information.
7. Tap **Done** to save the updated record sheet, or tap **Cancel** to exit without saving.

# 9 Settings

Selecting Settings application opens a setup screen to adjust the default setting and view information about the CR MAX system. There are eight system settings:

- **Unit**
- **Language**
- **Data Log**
- **WIFI**
- **Brightness**
- **Screen Sleep**
- **Vehicle Sorted By**
- **System Settings**
- **Click To Restore Factory Settings**

This section describes the operation procedures for the settings.

## 9.1 Unit

---

This option allows you to change the measurement unit for the diagnostic system.

- **To adjust the unit setting**
  1. Tap the **Settings** application on the CR MAX Job Menu.
  2. Tap the **Unit** option on the left column.
  3. Select the required measurement unit, Metric or English. A check mark will display on the right of the selected unit.
  4. Tap the **Back** button on the top left corner to return to the CR MAX home screen or select another setting.

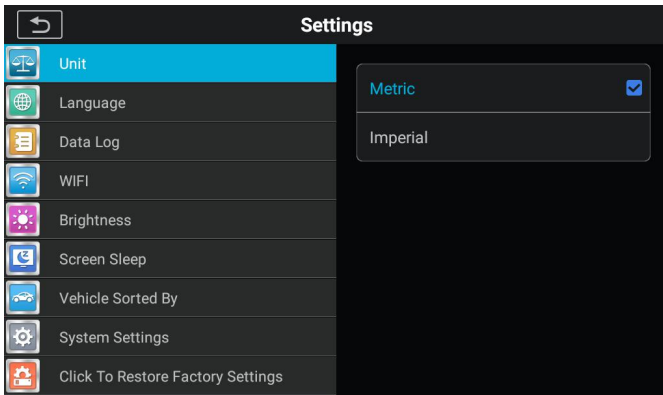

**Figure 9-1 Sample Unit Setting Screen**

## 9.2 Language

---

This option allows you to adjust the display language for the CR MAX system.

➤ **To adjust the language setting**

1. Tap the **Settings** application on the CR MAX Job Menu.
2. Tap the **Language** option on the left column.
3. Jump to the android language Settings interface, select the desired language, long press and drag up to the first bit, language Settings successful.
4. Click add language to add the desired language.
5. Tap the **Back** button on the bottom left corner to return to the CR MAX settings menu or select another setting.

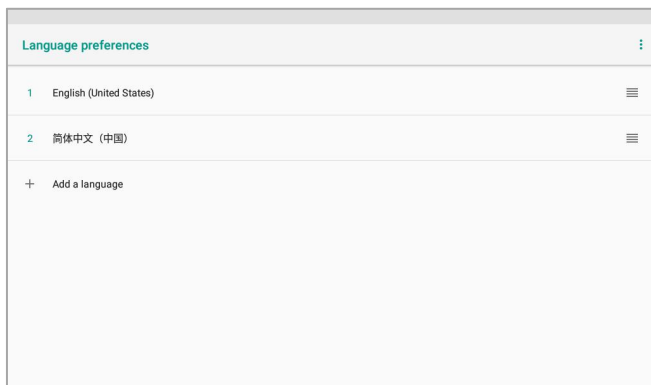

**Figure 9-2 Sample Language Setting Screen**

## 9.3 Data log

This option allows you to access the diagnostic system log. It's controlled by a slide switch. Turn on the switch, the diagnostic equipment will automatically backup the diagnostic files of the diagnostic system.

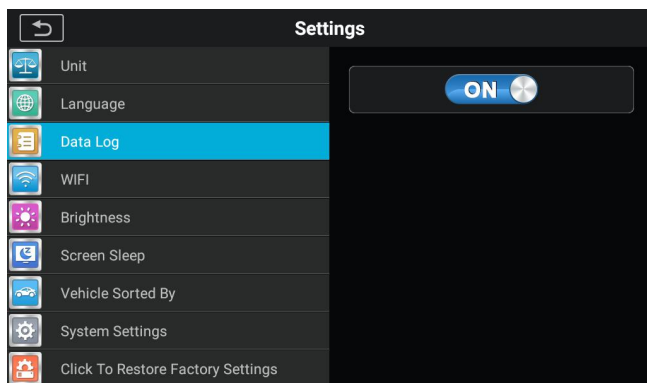

**Figure 9-3 Sample Data Log Screen**

### ➤ To adjust the data log Settings

1. Tap the **Settings** application on the CR MAX Job Menu.

2. Tap the **Data log** option on the left column.
3. Select the desired state, on or off.
4. Tap the **Back** button on the top left corner to return to the CR MAX home screen or select another setting.

## 9.4 WIFI

---

This option allows you to enter the Android background WiFi option settings and select the available network settings.

### ➤ To adjust the WIFI setting

1. Tap the **Settings** application on the CR MAX Job Menu.
2. Tap the **WIFI** option on the left column.
3. Skip to the WiFi Settings interface of Android and select the available network to set up the network.
4. Click the **Back** button in the bottom left corner to return to the CR MAX settings menu or select another setting.

## 9.5 Brightness

---

This option allows you to modify the brightness setting of the diagnostic system.

### ➤ To adjust the brightness setting

1. Tap the **Settings** application on the CR MAX Job Menu.
2. Tap the **brightness** option on the left column.
3. Slide the small points measured on the right by hand to select the appropriate height.
4. Click the **Back** button in the top left corner to return to the CR MAX home screen or select another setting.

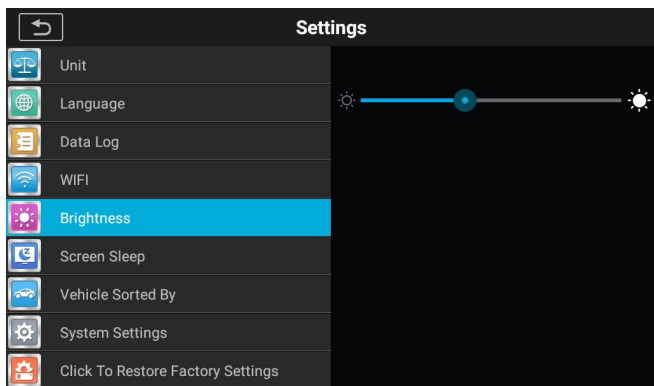

**Figure 9-4 Sample brightness Setting Screen**

## 9.6 Screen Sleep

---

This option allows you to modify the screen lock time setting for the diagnostic system.

➤ **To adjust the Screen Sleep setting**

1. Tap the **Settings** application on the CR MAX Job Menu.
2. Tap the **Screen Sleep** option on the left column.
3. Select the required screen sleep time. There are 8 options, namely 1 minute, 2 minutes, 5 minutes, 10 minutes, 15 minutes, 20 minutes, 30 minutes and 45 minutes. A check mark appears to the right of the selected cell.
4. Click the **Back** button in the top left corner to return to the CR MAX home screen or select another setting.

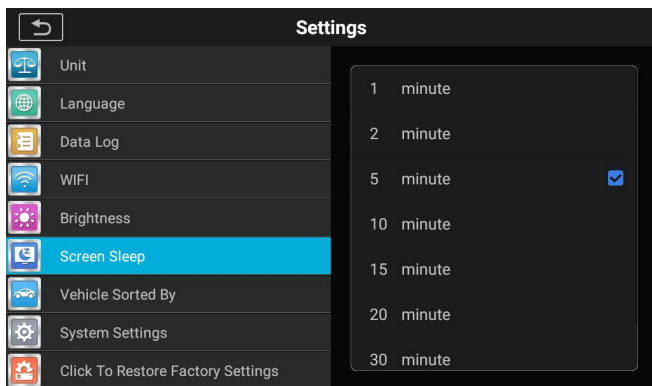

**Figure 9-5 Sample screen sleep Setting Screen**

## **9.7 Vehicle Sorted By**

---

This option allows you to modify the vehicle classification settings.

➤ **To adjust the Screen Sleep setting**

1. Tap the **Settings** application on the CR MAX Job Menu.
2. Tap the **Vehicle Sorted By** option on the left column.
3. Select the vehicle classification type you want, alphabetically or by frequency of use. A check mark appears to the right of the selected cell.
4. Click the **Back** button in the top left corner to return to the CR MAX home screen or select another setting.



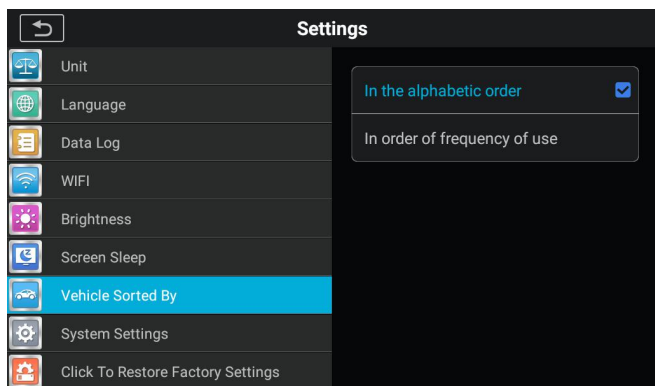

**Figure 9-6 Sample Vehicle Sorted By Setting Screen**

## 9.8 System Settings

---

Access the Android background system setting screen to adjust operating system settings including wireless and network settings, sound and display and system security settings. Android device information is also displayed.

➤ **To enable the App Switcher function**

1. Tap the **Settings** application on the CR MAX Job Menu.
2. Tap the **System settings** option on the left column.
3. Enter the Android background system settings screen and adjust the operating system settings, including setting screen lock, network settings, associated devices, applications and notifications, battery, display, sound, storage, fast bully, security and location information, users and accounts, accessibility, about the system, etc.
4. Click the **Back** button in the bottom left corner to return to the CR Max **settings** menu or select another setting.

Short pressing the App Switcher icon to open a control panel:

- Tap a specific app shortcut button to be directed to the selected

application screen.

- Long press a specific app shortcut button displays the app menu, on which you can select and change the app shortcut.
- Press and drag the App Switcher icon to another position alongside the edge of the screen.

Refer to Android documentation for information about Android system settings.

## 9.9 Click To Restore Factory Settings

---

This option allows you to return to factory settings.

- **To adjust to factory settings**
  1. Tap the **Settings** application on the CR MAX Job Menu.
  2. Tap the **Restore Factory Settings** option on the left column.
  3. This operation will initialize all data in the application settings, including unit, brightness, data switch, screen sleep and vehicle logo sorting.
  4. Click the **Back** button in the top left corner to return to the CR Max home screen or select another setting.

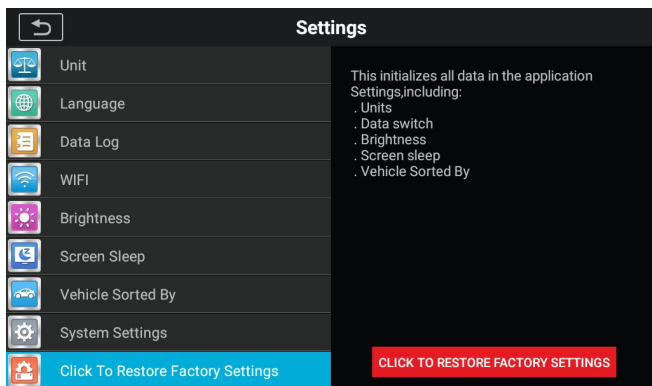

Figure 9-7 *Sample Restore Factory Setting Screen*

# 10 Quick Link

The Quick Link application provides access to ICarsoft's official website and to other popular automotive service websites. These sites are invaluable resources of automotive information and repair data and include forums, video training and expert consultation.

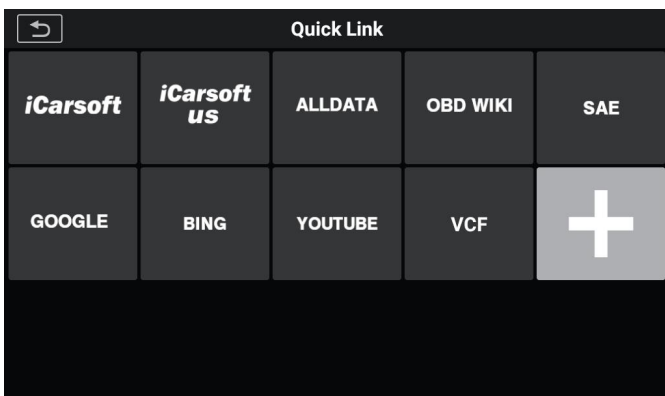

Figure 10-1 *Sample Quick Link Screen*

## ➤ To open a quick link

1. Tap the **Quick Link** application on the CR MAX Job Menu. The Quick Link application screen displays.
2. Select a website thumbnail from the main section. The Chrome browser is launched and the selected website is opened.
3. Now you can start exploring the website!

# 11 Fault Code

Fault code allows you to query the fault history and information description according to the model fault code. Slide up and down to select the required model and code.

➤ **To access fault code**

1. Tap the **Fault Code** application on the CR MAX Job Menu. The **Fault Code** application screen displays.
2. Slide up and down to select the required model and code.
3. Tap the lookup button in the upper right corner, and the query results will be displayed in the box below.
4. Tap the history button to view the relevant history.
5. Tap the information button to pop up the description of fault code information

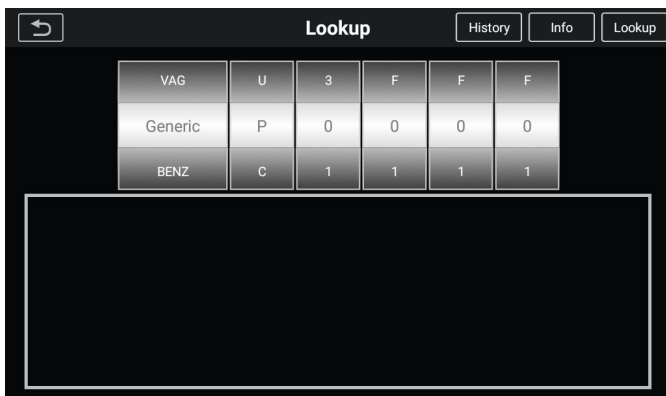

**Figure 11-1 Sample Fault Code Screen**

# 12 Support

This application launches the Support platform which synchronizes ICarsoft's on-line service base station with the Display Tablet. In order to synchronize the device to your on-line account, you need to register the product through the Internet when you use it for the first time. The Support application is connected to ICarsoft's service channel and on-line communities which provides the quickest way for problem solutions, allowing you to submit complaints or sent help requests to obtain direct services and supports.

## 12.1 Account

---

The " Account" screen displays product information, including product name, device, updates, and service information.

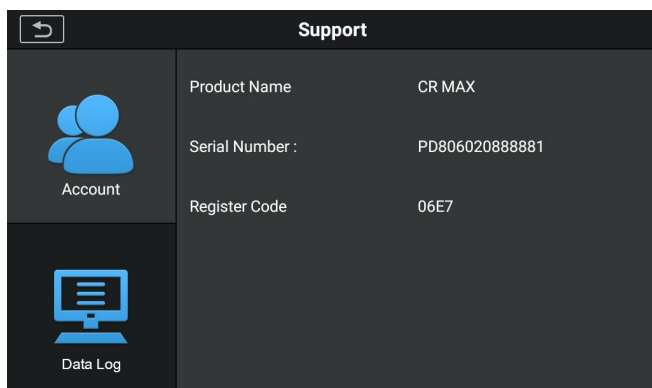

**Figure 12-1 Sample Account Screen**

## 12.2 Data Log

---

The "Data Log" screen displays the data log stored when the diagnostic device performs the diagnosis. When the log switch in the "Settings" option is turned on, the data log will be automatically stored. Select the check box behind the log, you can delete, you can

also provide information feedback.

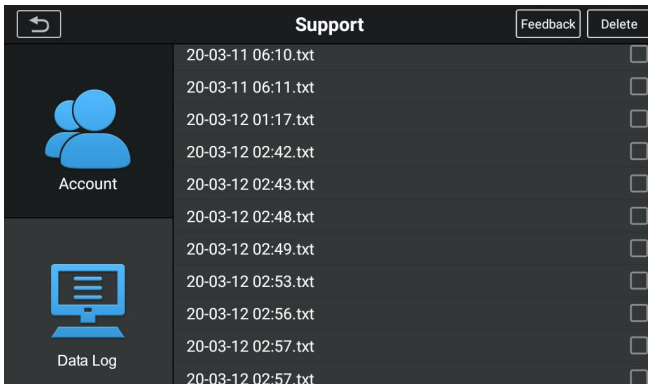

**Figure 12-2 Sample Data log Screen 1**

1. Select the check box behind the log, you can select multiple logs at the same time, tap the delete button in the upper right corner to delete.
2. Select the check box behind the log, you can select multiple logs at the same time, tap the feedback button in the upper right corner. The interface for information feedback will appear.

The screenshot shows a mobile application interface titled "Feedback". At the top, there is a back arrow icon, the title "Feedback", and an upload icon. Below the title bar, there is a form with the following fields: "Title", "Description", and "Vehicle information". The "Vehicle information" section is divided into two columns: "Make", "Model", and "Year" on the left; and "License", "VIN", and "Color" on the right. At the bottom, there is a note: "You can add 3 attachments at most and 100MB limit(id)!" with a plus sign icon.

**Figure 12-2 Sample Data log Screen 2**

- 3 Enter your title, description, vehicle information in the input box, and then tap the "upload" icon to submit your article. You can also press the  button to add up to 3 pictures to submit together.

# 13 Uninstall

This section allows you to manage the firmware applications installed on the CR MAX Diagnostics System. Select this section to open a management screen, on which you can check all the available vehicle diagnostic applications.

By clicking on each line of car brand to select the car firmware to be removed, the selected item displays a red flag in the check box on the right. Click the **Delete** button on the top bar to remove the firmware from the system database.

Uninstall the application screen is navigated through five simple buttons on the top navigation bar, describing each button from left to right:

- **Bcck Button** – returns to the CR MAX home screen.
- **Diagnostics Button** – press to select firmware for all diagnostic systems.
- **Service Button** – press to select firmware for all service systems.
- **SelectAll Button** –press to select all the firmware that the page displays.
- **Delete Button** –Remove the selected firmware.



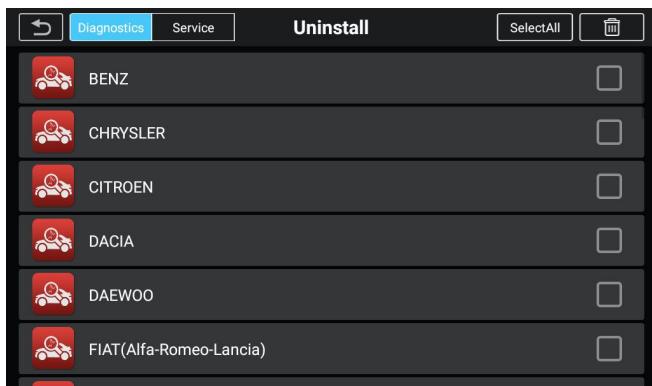
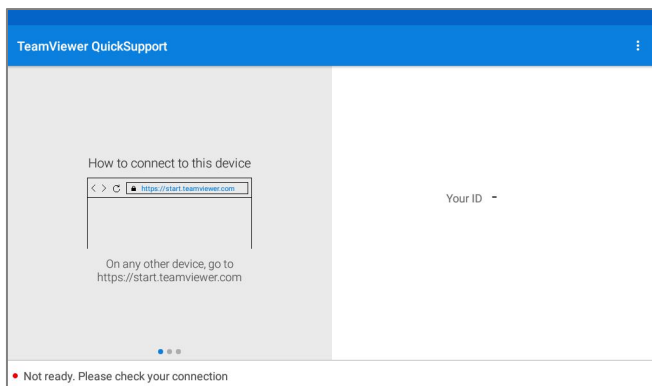

**Figure 13-1 Sample Uninstall Screen**

# 14 Remote Desk

The Remote Desk application launches the TeamViewer Quick Support program, a simple, fast and secure remote control screen. Use this application to receive ad-hoc remote support from ICarsoft's support technicians by allowing them to control your CR MAX tablet on their PC via the TeamViewer software.

Make sure the tablet is connected to the Internet before launching the Remote Desk application.



### **Figure 14-1 Sample Remote Desk Screen**

➤ **To receive remote support from a partner**

1. Power on the tablet.
2. Tap the **Remote Desk** application on the CR MAX Job Menu. The TeamViewer screen displays and the device ID is generated and shown.
3. Your partner must install the Remote Control software to his/her computer by downloading the TeamViewer full version program online (<http://www.teamviewer.com> ), and then start the software on his/her computer at the same time, in order to provide support and take control of the Display Tablet remotely.
4. Provide your ID to the partner, and wait for him/her to send you a remote control request.
5. A popup will display to ask for your confirmation to allow remote control on your device.
6. Tap **Allow** to accept, or tap **Deny** to reject.

Refer to the associated TeamViewer documents for additional information.

# 15 About

The About screen lists the CR MAX's version, hardware, and serial number.

- **To check the CR MAX product information in About**
  1. Tap the **Settings** application on the CR MAX Job Menu.
  2. Tap the **About** option on the left column. The product information screen displays on the right.
  3. Tap the **Back** button on the top left corner to return to the CR MAX home screen, or select another setting option for the system setup after viewing.



**Figure 15-1 Sample About Screen**

# 16 Maintenance and Service

## 16.1 Maintenance Instructions

---

The following shows how to maintain your devices, together with precautions to take.

- Use a soft cloth and alcohol or a mild window cleaner to clean the touch screen on the tablet.
- Do not use any abrasive cleansers, detergent, or automotive chemicals to the tablet.
- Only use the device in dry conditions within normal operating temperatures.
- Dry your hands before using the tablet. The touch screen of the tablet may not work if the touch screen is moist, or if you tap the touch screen with wet hands.
- Do not store the devices in humid, dusty or dirty areas.
- Before and after use, check the housing, wiring, and connectors for dirt and damage before and after each use.
- At the end of each work day, wipe the device housing, wiring, and connectors clean with a damp cloth.
- Do not attempt to disassemble your tablet or the VCI unit.
- Take care not drop the device or allow anything heavy to drop on the device.
- Use only authorized battery chargers and accessories. Any malfunction or damage caused by the use of unauthorized battery charger and accessories will void the limited product warranty.
- Ensure that the battery charger does not come in contact with conductive objects.

- Do not operate the tablet next to anything such as microwave oven, cordless phones and some medical or scientific instruments that might interfere with or prevent signal interference.

## 16.2 Troubleshooting Checklist

---

### A. When the Display Tablet does not work properly:

- Make sure the tablet has been registered online.
- Make sure the system software and diagnostic application software are properly updated.
- Make sure the tablet is connected to the Internet.
- Check all cables, connections, and indicators to see if the signal is being received.

### B. When battery life is shorter than usual:

- This may happen when you are in an area with low signal strength. Turn off your device when not in use.

### C. When you cannot turn on the tablet:

- Make sure the tablet is connected to a power source or the battery is charged.

### D. When you are unable to charge the tablet:

- Your charger maybe out of order. Contact your nearest dealer.
- You may be attempting to use the device in an overly hot/cold temperature. Try changing the charging environment.
- Your device may have not been connected to the charger properly. Check the connector.

---

### NOTE

If your problems persist, please contact ICarsoft's technical support personnel or your local selling agent.

---

## 16.3 About Battery Usage

---

Your tablet is powered by a built-in Lithium-ion Polymer battery. This means that, unlike other forms of battery technology, you can recharge your battery while some charge remains without reducing your tablet's autonomy due to the "battery memory effect" inherent in those technologies.

---

### DANGER

The built-in Lithium-ion Polymer battery is factory replaceable only; incorrect replacement or tampering with the battery pack may cause an explosion. Do not use a damaged battery charger.

---

- Do not disassemble or open crush, bend or deform, puncture or shred.
- Do not modify or remanufacture, attempt to insert foreign objects into the battery, expose to fire, explosion or other hazard.
- Make sure to use the charger and USB cables only that come together in the package. If you use the other charger and USB cables, you might incur malfunction or failure of the device.
- Only use the charging device that has been qualified with device per the standard. Use of an unqualified battery or charger may present a risk of fire, explosion, leakage, or other hazard.
- Avoid dropping the tablet. If the tablet is dropped, especially on a hard surface, and the user suspects damage, take it to a service center for inspection.
- The closer you are to your network's base station, the longer your tablet usage time because less battery power is consumed for the connection.
- The battery recharging time varies depending on the remaining battery capacity.
- Battery life inevitably shortens over time.
- Since over charging may shorten battery life, remove the tablet

from its charger once it is fully charged. Unplug the charger, once charging is complete.

- Leaving the tablet in hot or cold places, especially inside a car in summer or winter, may reduce the capacity and life of the battery. Always keep the battery within normal temperatures.

## 16.4 Service Procedures

---

This section introduces information for technical support, repair service, and application for replacement or optional parts.

### 16.4.1 Technical Support

If you have any question or problem on the operation of the product, please contact us (see the following contact info) or your local distributor.

#### ICARSOFT USA HQ

- Website: [www.icarsoft.us](http://www.icarsoft.us)  
[www.icarsoft.com](http://www.icarsoft.com)
- Email: [support@icarsoft.com](mailto:support@icarsoft.com)
- Address: Washington D.C.,20006 USA

### 16.4.2 Repair Service

If it becomes necessary to return your device for repair, please download the repair service form from [www.iCarsoft.com](http://www.iCarsoft.com), and fill it in. The following information must be included:

- Contact name
- Return address
- Telephone number
- Product name
- Complete description of the problem

- Proof-of-purchase for warranty repairs
- Preferred method of payment for non-warranty repairs



#### **NOTE**

For non-warranty repairs, payment can be made with Visa, Master Card, or with approved credit terms.

---

**Send the device to your local agent, please contact your dealer.**

### **16.4.3 Other Services**

You can purchase the optional accessories directly from iCarsoft's authorized tool suppliers, and/or your local distributor or agent.

Your purchase order should include the following information:

- Contact information
- Product or part name
- Item description
- Purchase quantity



# 17 Compliance Information

## FCC Compliance

This device complies with Part 15 of the FCC rules and Industry Canada's license-exempt RSSs. Operation is subject to the following two conditions:

1. This device may not cause harmful interference.
2. This device must accept any interference received, including interference that may cause undesired operation.

---

### WARNING

Changes or modifications not expressly approved by the party responsible for compliance could void the user's authority to operate the equipment.

---

### NOTE

This equipment has been tested and found to comply with the limits for a Class B digital device, pursuant to Part 15 of the FCC Rules. These limits are designed to provide reasonable protection against harmful interference in a residential installation.

---

This equipment generates uses and can radiate radio frequency energy and, if not installed and used in accordance with the instructions, may cause harmful interference to radio communications. However, there is no guarantee that interference will not occur in a particular installation. If this equipment does cause harmful interference to radio or television reception, which can be determined by turning the equipment off and on, the user is encouraged to try to correct the interference by one or more of the following measures:

- Reorient or relocate the receiving antenna.

- Increase the separation between the equipment and receiver.
- Connect the equipment into an outlet on a circuit different from that to which the receiver is connected.
- Consult the dealer or an experienced radio/TV technician for help.

Changes or modifications not expressly approved by the party responsible for compliance could void the user's authority to operate the equipment.

## **SAR**

The radiated output power of this device is below the FCC radio frequency exposure limits. Nevertheless, the device should be used in such a manner that the potential for human contact is minimized during normal operation.

The exposure standard for wireless devices employs a unit of measurement known as the Specific Absorption Rate, or SAR. The SAR limit set by the FCC is 1.6 W/Kg. Tests for SAR are conducted using standard operating positions accepted by the FCC with the device transmitting at its highest certified power level in all tested frequency bands. The highest reported SAR level for usage near the Body (0mm) is 0.254 W/kg

Although the SAR is determined at the highest certified power level, the actual SAR level of the device while operating can be well below the maximum value. This is because the device is designed to operate at multiple power levels so as to use only the power required to reach the network. To avoid the possibility of exceeding the FCC radio frequency exposure limits, human proximity to antenna should be minimized.

## **RF WARNING STATEMENT**

The device has been evaluated to meet general RF exposure requirement. The device can be used in portable exposure condition without restriction.

The term "IC" before the radio certification number only signifies that IC technical specifications were met.

## **RoHS COMPLIANCE**

This device is declared to be in compliance with the European RoHS Directive 2011/65/EU&2015/863/EU.

### **CE COMPLIANCE**

This product is declared to conform to the essential requirements of the following Directives and carries the CE mark accordingly:

EMC Directive

RED Directive

Low Voltage Directive

# 18 Warranty

## 18.1 Limited One Year Warranty

---

ICarsoft Technology Inc. (the Company) warrants to the original retail purchaser of this CR MAX Diagnostic Device, that should this product or any part thereof during normal consumer usage and conditions, be proven defective in material or workmanship that results in product failure within one (1) year period from the date of purchase, such defect(s) will be repaired, or replaced (with new or rebuilt parts) with Proof of Purchase, at the Company's option, without charge for parts or labor directly related to the defect(s).

The Company shall not be liable for any incidental or consequential damages arising from the use, misuse, or mounting of the device. Some states do not allow limitation on how long an implied warranty lasts, so the above limitations may not apply to you.

### **This warranty does not apply to:**

- a) Products subjected to abnormal use or conditions, accident, mishandling, neglect, unauthorized alteration, misuse, improper installation or repair or improper storage;
- b) Products whose mechanical serial number or electronic serial number has been removed, altered or defaced;
- c) Damage from exposure to excessive temperatures or extreme environmental conditions;
- d) Damage resulting from connection to, or use of any accessory or other product not approved or authorized by the Company;
- e) Defects in appearance, cosmetic, decorative or structural items such as framing and non-operative parts.
- f) Products damaged from external causes such as fire, dirt, sand, battery leakage, blown fuse, theft or improper usage of any

electrical source.

---

**!** **IMPORTANT**

All contents of the product may be deleted during the process of repair. You should create a back-up copy of any contents of your product before delivering the product for warranty service.

---