

## TEST REPORT

**Product** : Echelon Strength Cable Crossover Pro  
**Trade mark** : Echelon  
**Model/Type reference** : ECH-STCROSS-s-22  
**Serial Number** : N/A  
**Report Number** : EED32Q80705105  
**FCC ID** : 2AWD4-STCROSS22  
**Date of Issue** : oct. 31, 2024  
**Test Standards** : 47 CFR Part 15 Subpart E  
**Test result** : PASS

Prepared for:

**Echelon Fitness Multimedia, LLC**  
**605 Chestnut Street Suite 700, Chattanooga, TN USA 37450**

Prepared by:

**Centre Testing International Group Co., Ltd.**  
**Hongwei Industrial Zone, Bao'an 70 District,**  
**Shenzhen, Guangdong, China**  
**TEL: +86-755-3368 3668**  
**FAX: +86-755-3368 3385**

Compiled by:

*Keven Tan.*

Keven Tan

Reviewed by:

*Frazer Li*

Frazer Li

Approved by:

*Aaron Ma*

Aaron Ma

Date:

oct. 31, 2024



Check No.: 6737240524

## 1 Version

Version No.	Date	Description
00	oct. 31, 2024	Original

## 2 Test Summary

Test Item	Clause in FCC rules	Result
DFS Detection Threshold	15.407/KDB 905462 5.2	PASS
U-NII Detection Bandwidth	15.407/KDB 905462 7.8.1	N/A
Channel Availability Check Time	15.407/KDB 905462 7.8.2	N/A
Channel Move Time	15.407/KDB 905462 7.8.3	PASS
Channel Closing Transmission Time	15.407/KDB 905462 7.8.3	PASS
Non-Occupancy Period	15.407/KDB 905462 7.8.3	PASS
Statistical Performance Check	15.407/KDB 905462 7.8.4	N/A

Remark:

N/A: In this whole report not application

Company Name and Address shown on Report, the sample(s) and sample Information were provided by the applicant who should be responsible for the authenticity which CTI hasn't verified.

## 3 Content

<b>1 VERSION</b> .....	<b>2</b>
<b>2 TEST SUMMARY</b> .....	<b>3</b>
<b>3 CONTENT</b> .....	<b>4</b>
<b>4 GENERAL INFORMATION</b> .....	<b>5</b>
4.1 CLIENT INFORMATION .....	5
4.2 GENERAL DESCRIPTION OF EUT .....	5
4.3 DESCRIPTION OF SUPPORT UNITS .....	7
4.4 TEST LOCATION .....	7
4.5 APPLIED STANDARDS .....	7
<b>5 EQUIPMENT LIST</b> .....	<b>8</b>
<b>6 DFS TECHNICAL REQUIREMENTS AND RADAR TEST WAVEFORMS</b> .....	<b>9</b>
6.1 DFS OVERVIEW .....	9
6.2 DFS DETECTION THRESHOLDS .....	9
6.3 RADAR TEST WAVEFORMS .....	11
6.3.1 <i>Short Pulse Radar Test Waveforms</i> .....	11
6.3.2 <i>Long Pulse Radar Test Waveforms</i> .....	12
<b>7 TEST REQUIREMENT TEST SETUP</b> .....	<b>13</b>
<b>8 TEST CASE RESULTS</b> .....	<b>15</b>
8.1 DFS DETECTION THRESHOLDS .....	15
8.2 IN-SERVICE MONITORING FOR CHANNEL MOVE TIME, CHANNEL CLOSING TRANSMISSION TIME AND NON-OCCUPANCY PERIOD .....	42
<b>DFS TEST SETUP</b> .....	<b>54</b>
<b>PHOTOGRAPHS OF EUT CONSTRUCTIONAL DETAILS</b> .....	<b>55</b>

## 4 General Information

### 4.1 Client Information

Applicant:	Echelon Fitness Multimedia, LLC
Address of Applicant:	605 Chestnut Street Suite 700, Chattanooga, TN USA 37450
Manufacturer:	Guangzhou Yuandong Smart Sports Technology Co., Ltd
Address of Manufacturer:	Room 192 Kezhu Road, Huangpu District, Guangzhou
Factory:	Shandong Relax Sports Technology Co.,Ltd.
Address of Factory:	No. 101 Shantou Road, Rizhao, Shandong, China

### 4.2 General Description of EUT

Product Name:	Echelon Strength Cable Crossover Pro
Model No. (EUT):	ECH-STCROSS-s-22
Trade Mark:	Echelon
Type of Modulation:	IEEE 802.11a: OFDM (BPSK, QPSK, 16QAM, 64QAM) IEEE 802.11n(HT20/HT40): OFDM (BPSK, QPSK, 16QAM, 64QAM) IEEE 802.11ac(VHT20/VHT40/VHT80): OFDM (BPSK, QPSK, 16QAM, 64QAM, 256QAM)
Operating Frequency	U-NII-1: 5150-5250MHz U-NII-2A: 5250-5350MHz U-NII-2C:5500-5700MHz U-NII-3:5745-5825MHz
Operating Temperature:	0°C to +40°C
Sample Type:	<input type="checkbox"/> Mobile <input type="checkbox"/> Portable <input checked="" type="checkbox"/> Fixed Location
Test Power Grade:	Default
Test Software of EUT:	adb.exe
Antenna Type:	FPC Antenna
Antenna gain:	U-NII-1: ANT1: 3.85, ANT2: 3.86 U-NII-2A: ANT1: 3.85, ANT2: 3.55 U-NII-2C: ANT1: 3.54, ANT2: 4.24 U-NII-3: ANT1: 3.87, ANT2: 3.51
Function	<input checked="" type="checkbox"/> SISO <input checked="" type="checkbox"/> 2x2 MIMO <input type="checkbox"/> 3x3 MIMO <input type="checkbox"/> 4x4MIMO
Operating Mode	<input type="checkbox"/> Master <input type="checkbox"/> Client with radar detection <input type="checkbox"/> Client without radar detection
Power Supply:	Adapter: DC12V
Test voltage:	DC12V
Sample Received Date:	Jul. 23, 2024
Sample tested Date:	Jul. 23, 2024 to Aug. 14, 2024

Operation Frequency each of channel

802.11a/802.11n/802.11ac(20MHz) Frequency/Channel Operations:

U-NII-1		U-NII-2A		U-NII-2C		U-NII-3	
Channel	Frequency(MHz)	Channel	Frequency(MHz)	Channel	Frequency(MHz)	Channel	Frequency(MHz)
36	5180	52	5260	100	5500	149	5745
40	5200	56	5280	104	5520	153	5765
44	5220	60	5300	108	5540	157	5785
48	5240	64	5320	112	5560	161	5805
-	-	-	-	116	5580	165	5825
-	-	-	-	132	5660	-	-
-	-	-	-	136	5680	-	-
-	-	-	-	140	5700	-	-

802.11n/802.11ac(40MHz) Frequency/Channel Operations:

U-NII-1		U-NII-2A		U-NII-2C		U-NII-3	
Channel	Frequency(MHz)	Channel	Frequency(MHz)	Channel	Frequency(MHz)	Channel	Frequency(MHz)
38	5190	54	5270	102	5510	151	5755
46	5230	62	5310	110	5550	159	5795
-	-	-	-	134	5670	-	-
-	-	-	-	142	5710	-	-

802.11ac(80MHz) Frequency/Channel Operations:

U-NII-1		U-NII-2A		U-NII-2C		U-NII-3	
Channel	Frequency(MHz)	Channel	Frequency(MHz)	Channel	Frequency(MHz)	Channel	Frequency(MHz)
42	5210	58	5290	106	5530	155	5775
-	-	-	-	122	5610	-	-

### 4.3 Description of Support Units

The EUT has been tested with associated equipment below.

1) support equipment

Description	Manufacturer	Model No.	Certification	Supplied by
Netbook	HP	DESKTOP-H31GDCQ	FCC&CE	CTI

### 4.4 Test Location

All tests were performed at:

Centre Testing International Group Co., Ltd

Building C, Hongwei Industrial Park Block 70, Bao'an District, Shenzhen, China

Telephone: +86 (0) 755 33683668 Fax: +86 (0) 755 33683385

No tests were sub-contracted.

FCC Designation No.: CN1164

### 4.5 Applied Standards

According to the specifications of the manufacturer, it must comply with the requirements of the following standards:

FCC CFR47 Part 15E Unlicensed National Information Infrastructure Devices

FCC KDB 905462 D02 UNII DFS Compliance Procedures New Rules v02

FCC KDB 905462 D03 Client Without DFS New Rules v01r02.

## 5 Equipment List

RF test system					
Equipment	Manufacturer	Model No.	Serial Number	Cal. Date (mm-dd-yyyy)	Cal. Due date (mm-dd-yyyy)
Communication test set	R&S	CMW500	107929	06-26-2024	06-25-2025
Signal Generator	R&S	SMBV100A	1407.6004K02-262149-CV	09-05-2023	09-04-2024
Spectrum Analyzer	R&S	FSV40	101200	07-18-2024	07-17-2025
RF control unit(power unit)	MWRF-test	MW100-RFCB	MW220620CTI-42	06-25-2024	06-24-2025
High-low temperature test chamber	Dong Guang Qin Zhuo	LK-80GA	QZ20150611879	11-12-2023	12-10-2024
Temperature/ Humidity Indicator	biaozhi	HM10	1804186	05-29-2024	05-28-2025
BT&WI-FI Automatic test software	MWRF-test	MTS 8310	V2.0.0.0	---	---
Spectrum Analyzer	R&S	FSV3044	101509	01-17-2024	01-16-2025



## 6 DFS Technical Requirements and Radar Test Waveforms

### 6.1 DFS Overview

**Table 1 Applicability of DFS Requirements Prior to Use of a Channel**

Requirement	Operational Mode		
	Master	Client without Radar Detection	Client with Radar Detection
Non-Occupancy Period	Yes	Not required	Yes
DFS Detection Threshold	Yes	Not required	Yes
Channel Availability Check Time	Yes	Not required	Not required
U-NII Detection Bandwidth	Yes	Not required	Yes

**Table 2 Applicability of DFS requirements during normal operation**

Requirement	Operational Mode	
	Master Device or Client with Radar Detection	Client without Radar Detection
DFS Detection Threshold	Yes	Not require
Channel Closing Transmission Time	Yes	Yes
Channel Move Time	Yes	Yes
U-NII Detection Bandwidth	Yes	Not required

Additional requirements for devices with multiple bandwidth modes	Master Device or Client with Radar Detection	Client without Radar Detection
U-NII Detection Bandwidth and Statistical Performance Check	All BW modes must be tested	Not required
Channel Move Time and Channel Closing Transmission Time	Test using widest BW mode available	Test using the widest BW mode available for the link
All other tests	Any single BW mode	Not required

Note: Frequencies selected for statistical performance check should include several frequencies within the radar detection bandwidth and frequencies near the edge of the radar detection bandwidth. For 802.11 devices it is suggested to select frequencies in each of the bonded 20 MHz channels and the channel center frequency.

### 6.2 DFS Detection Thresholds

**Table 3 DFS Detection Thresholds for Master Devices and Client Devices With Radar Detection**

Maximum Transmit Power	Value(See Notes 1, 2 and 3)
EIRP $\geq$ 200 milliwatt	-64 dBm
EIRP < 200 milliwatt and power spectral density < 10 dBm/MHz	-62 dBm
EIRP < 200 milliwatt that do not meet the power spectral density requirement	-64 dBm

Note 1: This is the level at the input of the receiver assuming a 0 dBi receive antenna.

Note 2: Throughout these test procedures an additional 1 dB has been added to the amplitude of the test transmission waveforms to account for variations in measurement equipment. This will ensure that the test signal is at or above the detection threshold level to trigger a DFS response.

Note3: EIRP is based on the highest antenna gain. For MIMO devices refer to KDB Publication 662911 D01.

**Table 4 DFS Response Requirement Values**

Parameter	Value
Non- occupancy period	Minimum 30 minutes
Channel Availability Check Time	60 seconds
Channel Move Time	10 seconds See Note 1
Channel Closing Transmission Time	200 milliseconds + an aggregate of 60milliseconds over remaining 10 second period. See Notes 1 and 2
U-NII Detection Bandwidth	Minimum 100% of the UNII99% transmission power bandwidth See Note 3
<p>Note 1: Channel Move Time and the Channel Closing Transmission Time should be performed with Radar Type 0. The measurement timing begins at the end of the Radar Type 0 burst.</p> <p>Note 2: The Channel Closing Transmission Time is comprised of 200 milliseconds starting at the beginning of the Channel Move Time plus any additional intermittent control signals required to facilitate a Channel move (an aggregate of 60 milliseconds) during the remainder of the 10 second period. The aggregate duration of control signals will not count quiet periods in between transmissions.</p> <p>Note 3: During the U-NII Detection Bandwidth detection test, radar type 0 should be used. For each frequency step the minimum percentage of detection is 90 percent. Measurements are performed with no data traffic.</p>	

## 6.3 Radar Test Waveforms

### 6.3.1 Short Pulse Radar Test Waveforms

**Table 5 – Short Pulse Radar Test Waveforms**

Radar Type	Pulse Width (μsec)	PRI (μsec)	Number of Pulses	Minimum Percentage of Successful Detection	Minimum Number of Trials
0	1	1428	18	See Note 1	See Note 1
1	1	Test A: 15 unique PRI values randomly selected from the list of 23 PRI values in Table 5a	$\text{Roundup} \left\{ \left( \frac{1}{360} \right) \cdot \left( \frac{19 \cdot 10^6}{\text{PRI}_{\mu\text{sec}}} \right) \right\}$	60%	30
		Test B: 15 unique PRI values randomly selected within the range of 518-3066 μsec, with a minimum increment of 1 μsec, excluding PRI values selected in Test A			
2	1-5	150-230	23-29	60%	30
3	6-10	200-500	16-18	60%	30
4	11-20	200-500	12-16	60%	30
Aggregate (Radar Types 1-4)				80%	120
<b>Note 1: Short Pulse Radar Type 0 should be used for the detection bandwidth test, channel move time, and channel closing time tests.</b>					

A minimum of 30 unique waveforms are required for each of the Short Pulse Radar Types 2 through 4. If more than 30 waveforms are used for Short Pulse Radar Types 2 through 4, then each additional waveform must also be unique and not repeated from the previous waveforms. If more than 30 waveforms are used for Short Pulse Radar Type 1, then each additional waveform is generated with Test B and must also be unique and not repeated from the previous waveforms in Tests A or B.

For example if in Short Pulse Radar Type 1 Test B a PRI of 3066 μsec is selected, the number of pulses

would be 
$$\text{Roundup} \left\{ \left( \frac{1}{360} \right) \cdot \left( \frac{19 \cdot 10^6}{3066} \right) \right\} = \text{Round up } \{17.2\} = 18.$$

**Table 5a - Pulse Repetition Intervals Values for Test A**

Pulse Repetition Frequency Number	Pulse Repetition Frequency (Pulses Per Second)	Pulse Repetition Interval (Microseconds)
1	1930.5	518
2	1858.7	538
3	1792.1	558
4	1730.1	578
5	1672.2	598
6	1618.1	618
7	1567.4	638
8	1519.8	658
9	1474.9	678
10	1432.7	698
11	1392.8	718
12	1355	738
13	1319.3	758
14	1285.3	778
15	1253.1	798
16	1222.5	818
17	1193.3	838
18	1165.6	858
19	1139	878
20	1113.6	898
21	1089.3	918
22	1066.1	938
23	326.2	3066

The aggregate is the average of the percentage of successful detections of Short Pulse Radar Types 1-4. For example, the following table indicates how to compute the aggregate of percentage of successful detections.

Radar Type	Number of Trials	Number of Successful Detections	Minimum Percentage of Successful Detection
1	35	29	82.9%
2	30	18	60%
3	30	27	90%
4	50	44	88%
Aggregate $(82.9\% + 60\% + 90\% + 88\%)/4 = 80.2\%$			

### 6.3.2 Long Pulse Radar Test Waveforms

**Table 6 – Long Pulse Radar Test Waveform**

Radar Type	Pulse Width (µsec)	Chirp Width (MHz)	PRI (µsec)	Number of Pulses per Burst	Number of Bursts	Minimum Percentage of Successful Detection	Minimum Number of Trials
5	50-100	5-20	1000-2000	1-3	8-20	80%	30

The parameters for this waveform are randomly chosen. Thirty unique waveforms are required for the Long Pulse Radar Type waveforms. If more than 30 waveforms are used for the Long Pulse Radar Type waveforms, then each additional waveform must also be unique and not repeated from the previous waveforms.

**Table 7 – Frequency Hopping Radar Test Waveform**

Radar Type	Pulse Width (μsec)	PRI (μsec)	Pulses per Hop	Hopping Rate (kHz)	Hopping Sequence Length (msec)	Minimum Percentage of Successful Detection	Minimum Number of Trials
6	1	333	9	0.333	300	70%	30

For the Frequency Hopping Radar Type, the same Burst parameters are used for each waveform. The hopping sequence is different for each waveform and a 100-length segment is selected from the hopping sequence defined by the following algorithm: The first frequency in a hopping sequence is selected randomly from the group of 475 integer frequencies from 5250 – 5724 MHz. Next, the frequency that was just chosen is removed from the group and a frequency is randomly selected from the remaining 474 frequencies in the group. This process continues until all 475 frequencies are chosen for the set. For selection of a random frequency, the frequencies remaining within the group are always treated as equally likely.

错误!未找到引用源。

## 7 Test Requirement Test setup

### Setup for Master with injection at the Master

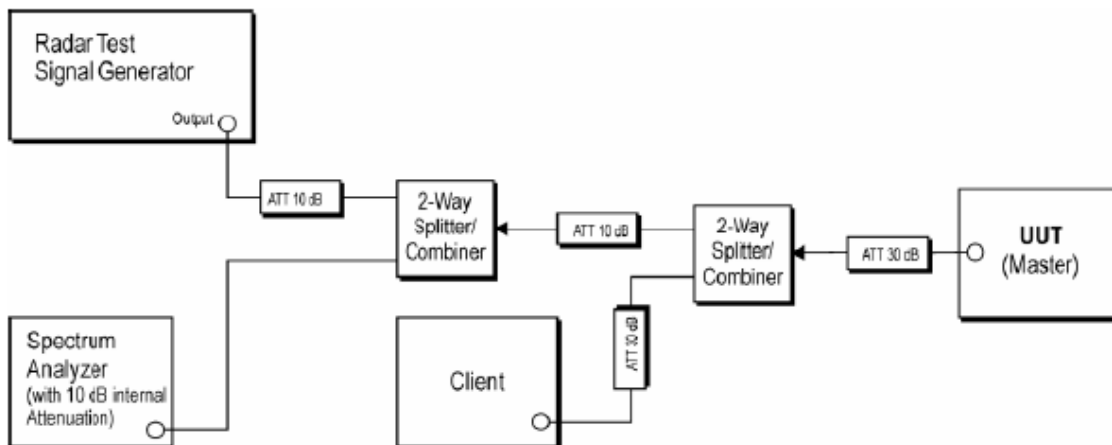

Example Conducted Setup where UUT is a Master and Radar Test Waveforms are injected into the Master.

### Setup for Client with injection at the Master

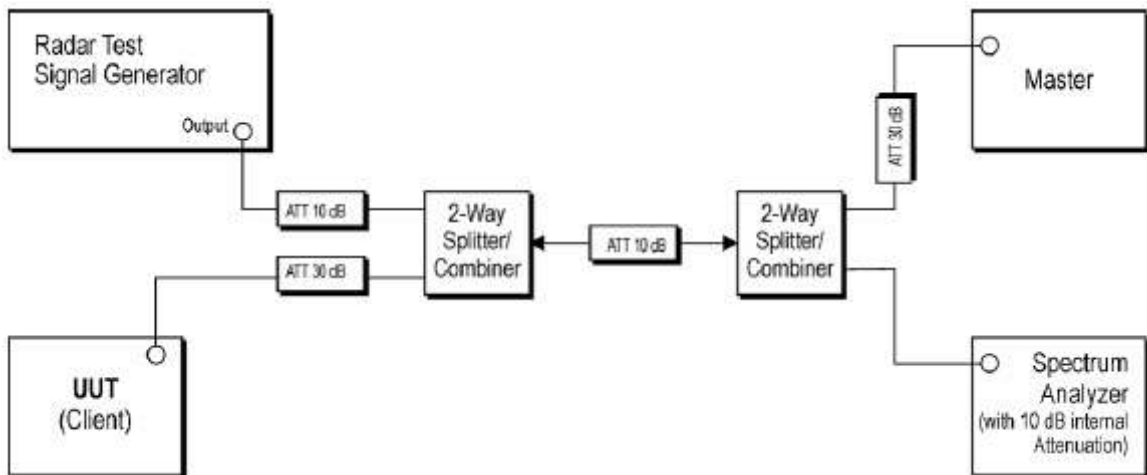

Example Conducted Setup where UUT is a Client and Radar Test Waveforms are injected into the Master

### Setup for Client with injection at the Client

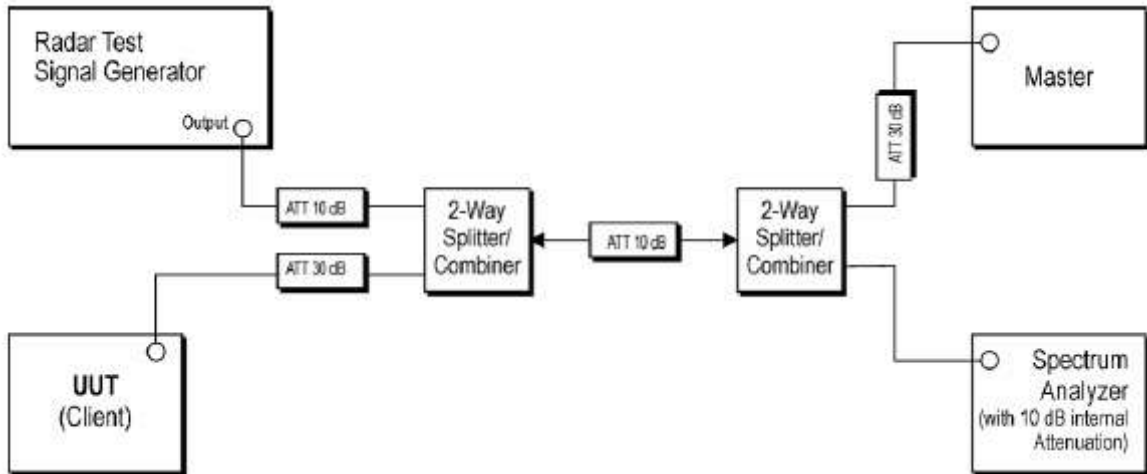

Example Conducted Setup where UUT is a Client and Radar Test Waveforms are injected into the Client.

## 8 Test Case Results

### 8.1 DFS Detection Thresholds

#### Ambient condition

Temperature	Relative humidity	Pressure
23°C ~25°C	45%~50%	101.5kPa

#### Methods of Measurement

Client with injection at the Master.

For a detection threshold level of -64dBm, the required signal strength at EUT antenna location is -64dBm, the tested level is lower than required level hence it provides margin to the limit.

#### Calibration Result

Mode	Frequency (MHz)	Type	Result	Verdict
ac20	5260	DFS_FCC_T0	See test Graph	Pass
ac20	5260	DFS_FCC_T1000	See test Graph	Pass
ac20	5260	DFS_FCC_T2000	See test Graph	Pass
ac20	5260	DFS_FCC_T3000	See test Graph	Pass
ac20	5260	DFS_FCC_T4000	See test Graph	Pass
ac20	5260	DFS_FCC_T5000	See test Graph	Pass
ac20	5260	DFS_FCC_T6000	See test Graph	Pass
ac20	5500	DFS_FCC_T0	See test Graph	Pass
ac20	5500	DFS_FCC_T1000	See test Graph	Pass
ac20	5500	DFS_FCC_T2000	See test Graph	Pass
ac20	5500	DFS_FCC_T3000	See test Graph	Pass
ac20	5500	DFS_FCC_T4000	See test Graph	Pass
ac20	5500	DFS_FCC_T5000	See test Graph	Pass
ac20	5500	DFS_FCC_T6000	See test Graph	Pass
ac40	5270	DFS_FCC_T0	See test Graph	Pass
ac40	5270	DFS_FCC_T1000	See test Graph	Pass
ac40	5270	DFS_FCC_T2000	See test Graph	Pass
ac40	5270	DFS_FCC_T3000	See test Graph	Pass
ac40	5270	DFS_FCC_T4000	See test Graph	Pass
ac40	5270	DFS_FCC_T5000	See test Graph	Pass
ac40	5270	DFS_FCC_T6000	See test Graph	Pass
ac40	5510	DFS_FCC_T0	See test Graph	Pass
ac40	5510	DFS_FCC_T1000	See test Graph	Pass

ac40	5510	DFS_FCC_T2000	See test Graph	Pass
ac40	5510	DFS_FCC_T3000	See test Graph	Pass
ac40	5510	DFS_FCC_T4000	See test Graph	Pass
ac40	5510	DFS_FCC_T5000	See test Graph	Pass
ac40	5510	DFS_FCC_T5000	See test Graph	Pass
ac40	5510	DFS_FCC_T6000	See test Graph	Pass
ac80	5290	DFS_FCC_T0	See test Graph	Pass
ac80	5290	DFS_FCC_T1000	See test Graph	Pass
ac80	5290	DFS_FCC_T2000	See test Graph	Pass
ac80	5290	DFS_FCC_T3000	See test Graph	Pass
ac80	5290	DFS_FCC_T4000	See test Graph	Pass
ac80	5290	DFS_FCC_T5000	See test Graph	Pass
ac80	5290	DFS_FCC_T6000	See test Graph	Pass
ac80	5530	DFS_FCC_T0	See test Graph	Pass
ac80	5530	DFS_FCC_T1000	See test Graph	Pass
ac80	5530	DFS_FCC_T2000	See test Graph	Pass
ac80	5530	DFS_FCC_T3000	See test Graph	Pass
ac80	5530	DFS_FCC_T4000	See test Graph	Pass
ac80	5530	DFS_FCC_T5000	See test Graph	Pass
ac80	5530	DFS_FCC_T6000	See test Graph	Pass
ac80	5610	DFS_FCC_T0	See test Graph	Pass
ac80	5610	DFS_FCC_T1	See test Graph	Pass
ac80	5610	DFS_FCC_T2	See test Graph	Pass
ac80	5610	DFS_FCC_T3	See test Graph	Pass
ac80	5610	DFS_FCC_T4	See test Graph	Pass
ac80	5610	DFS_FCC_T5	See test Graph	Pass
ac80	5610	DFS_FCC_T6	See test Graph	Pass

Note: Only the worst case data was recorded in the report.



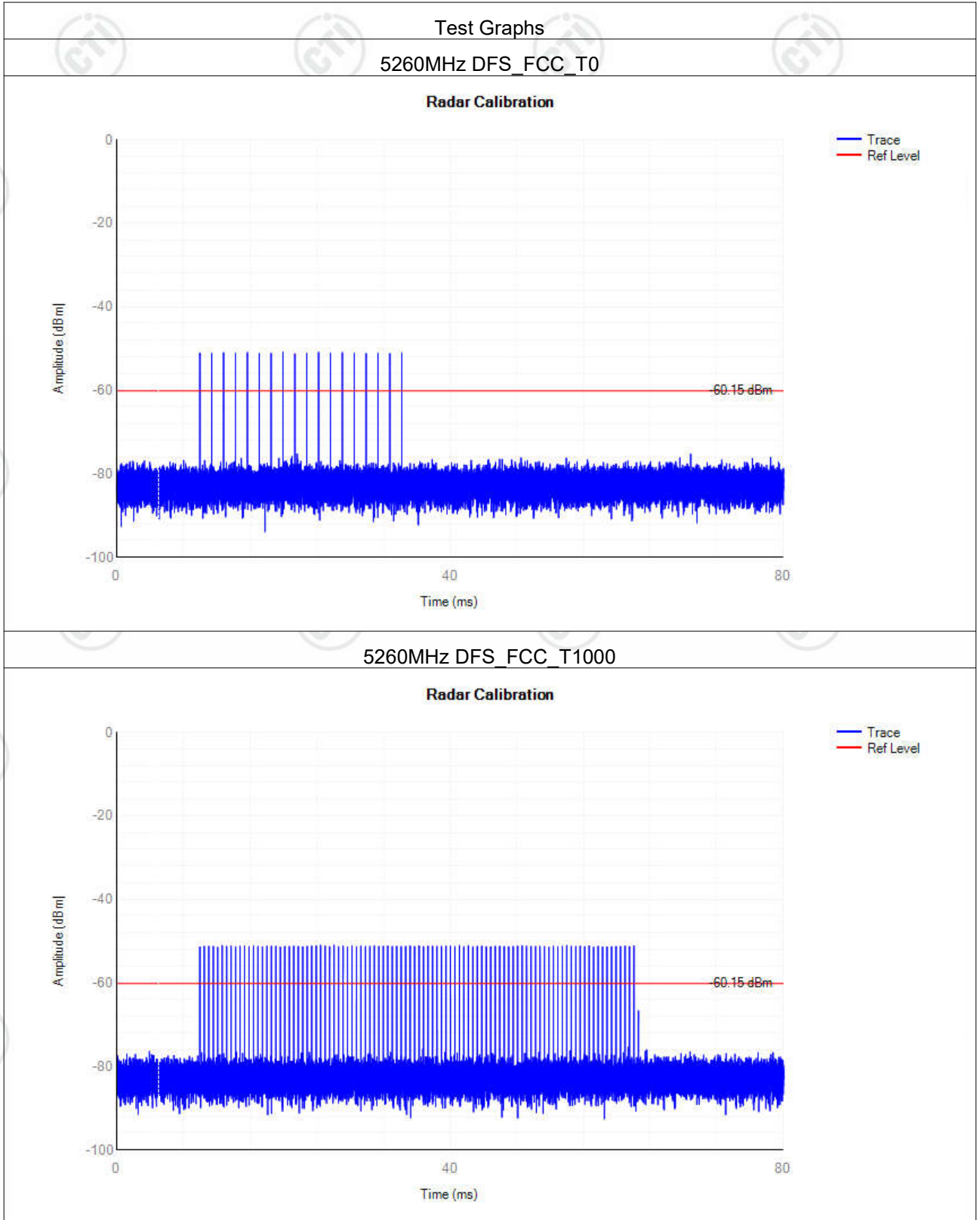

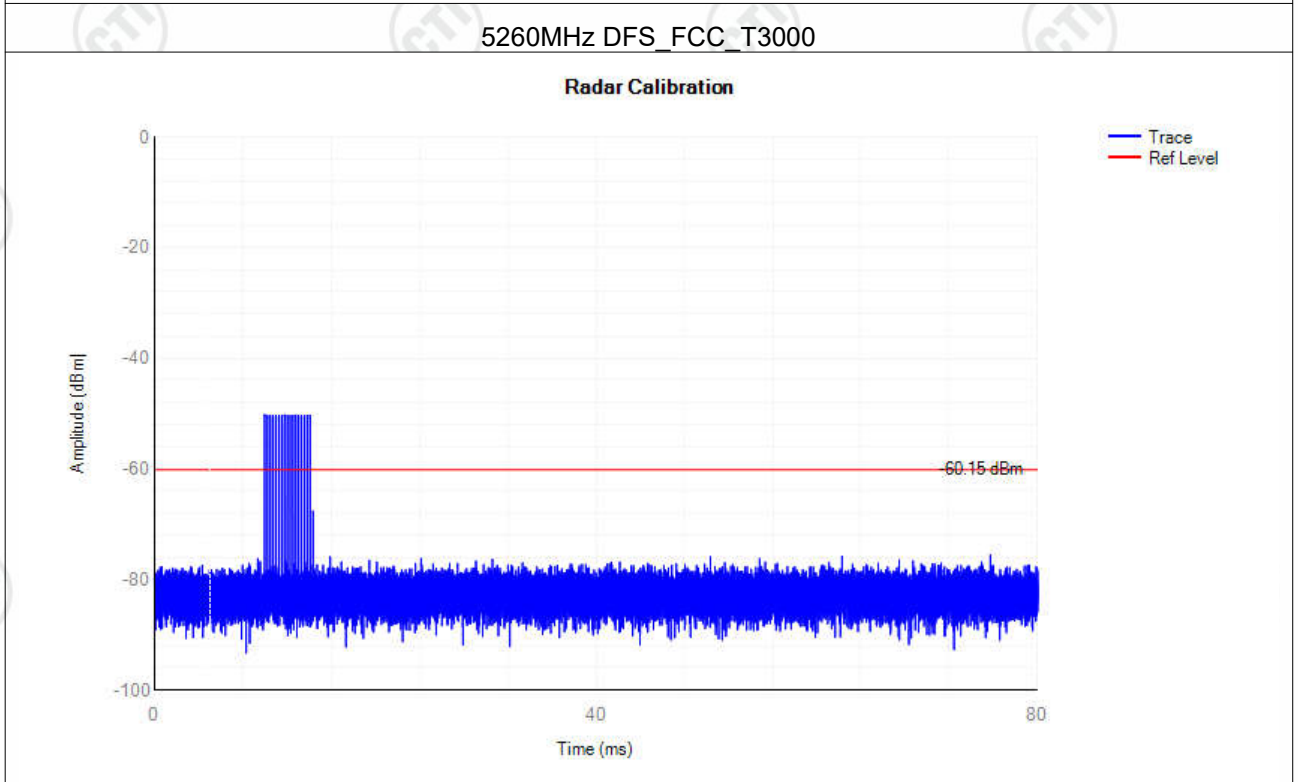
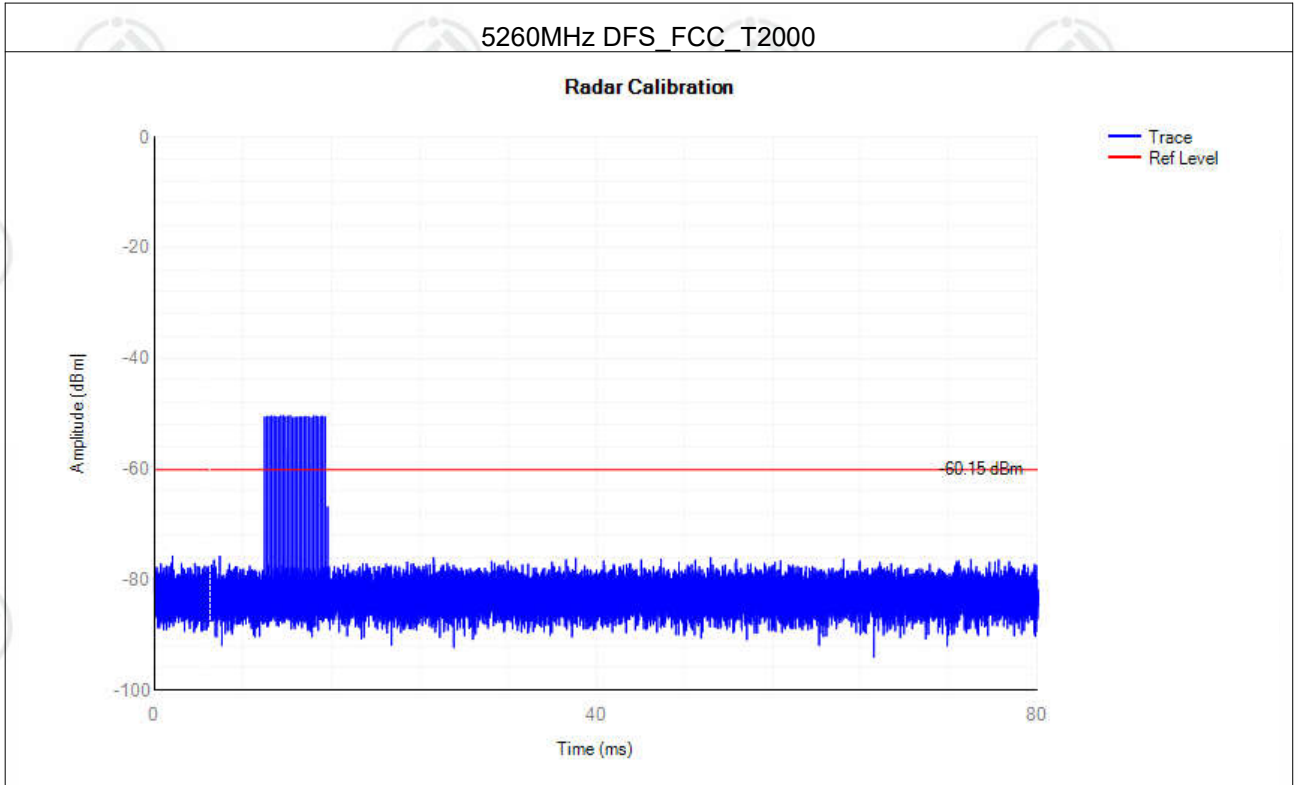

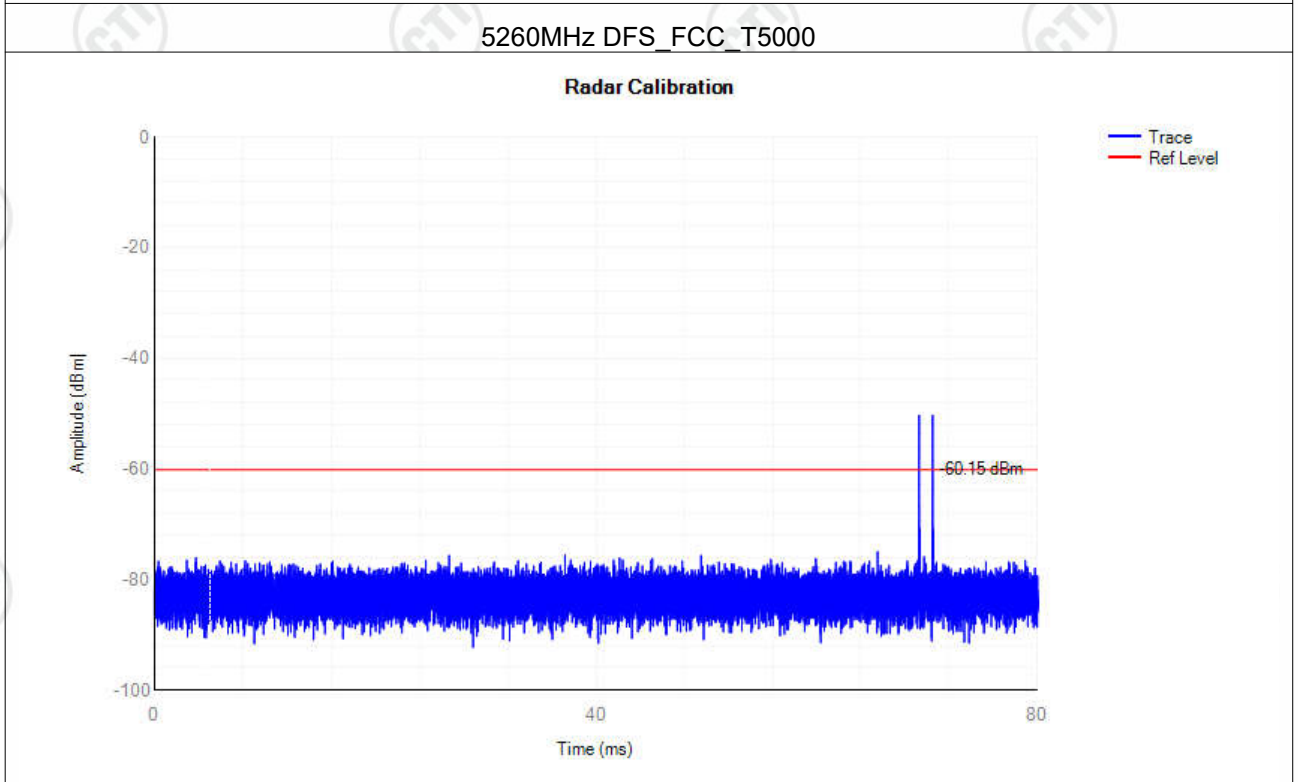
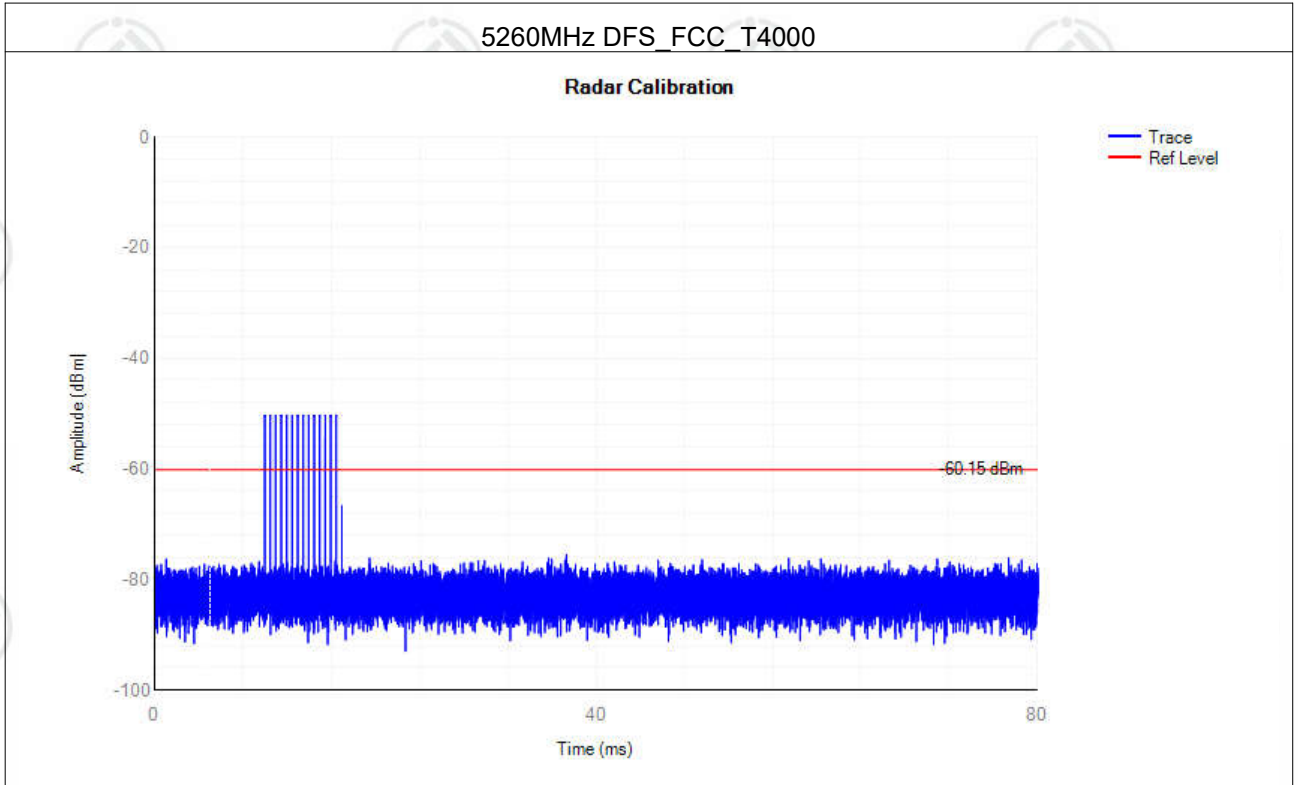

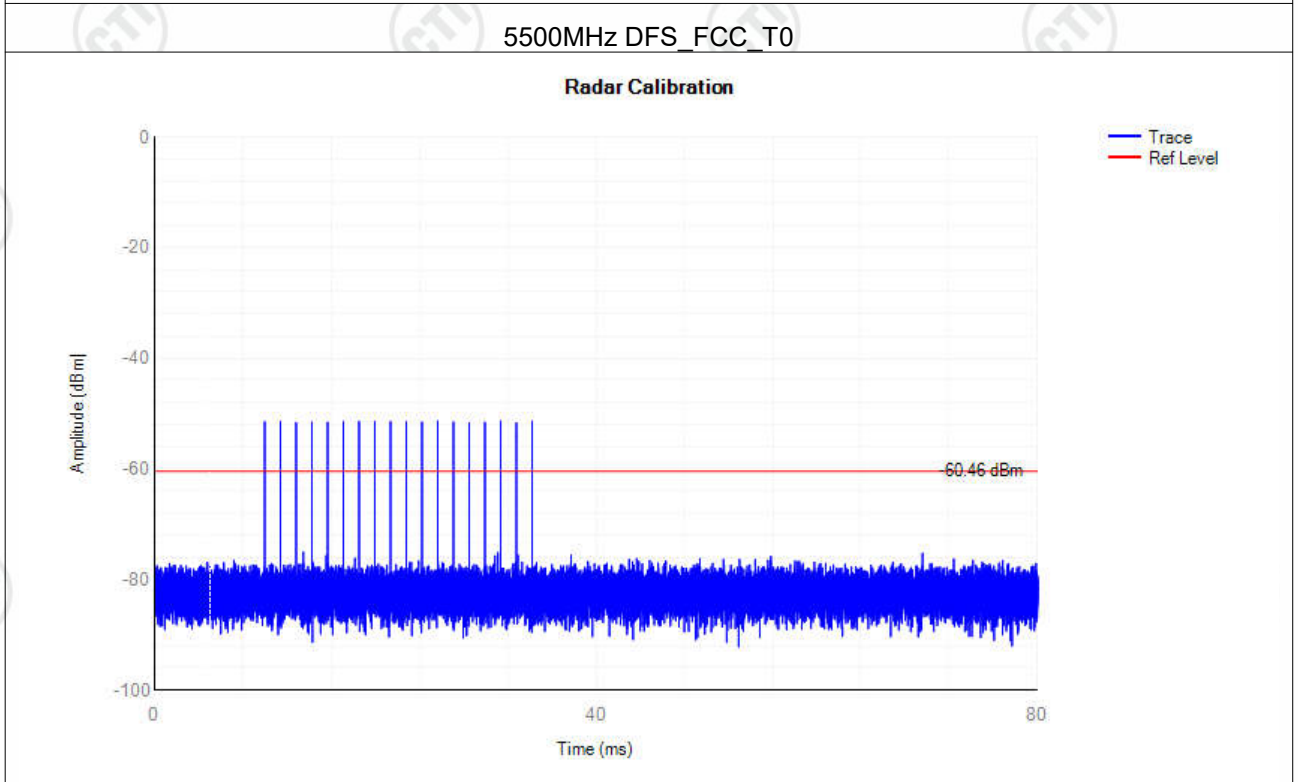
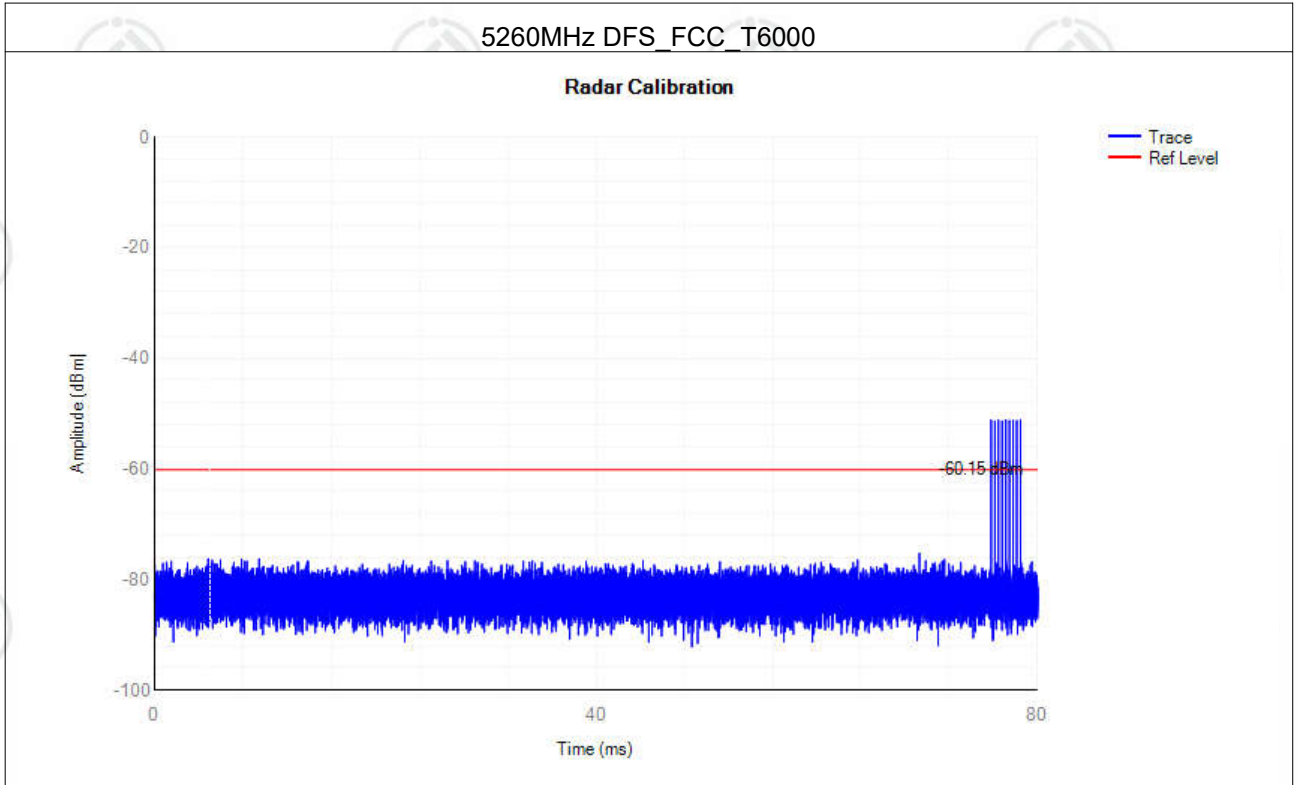

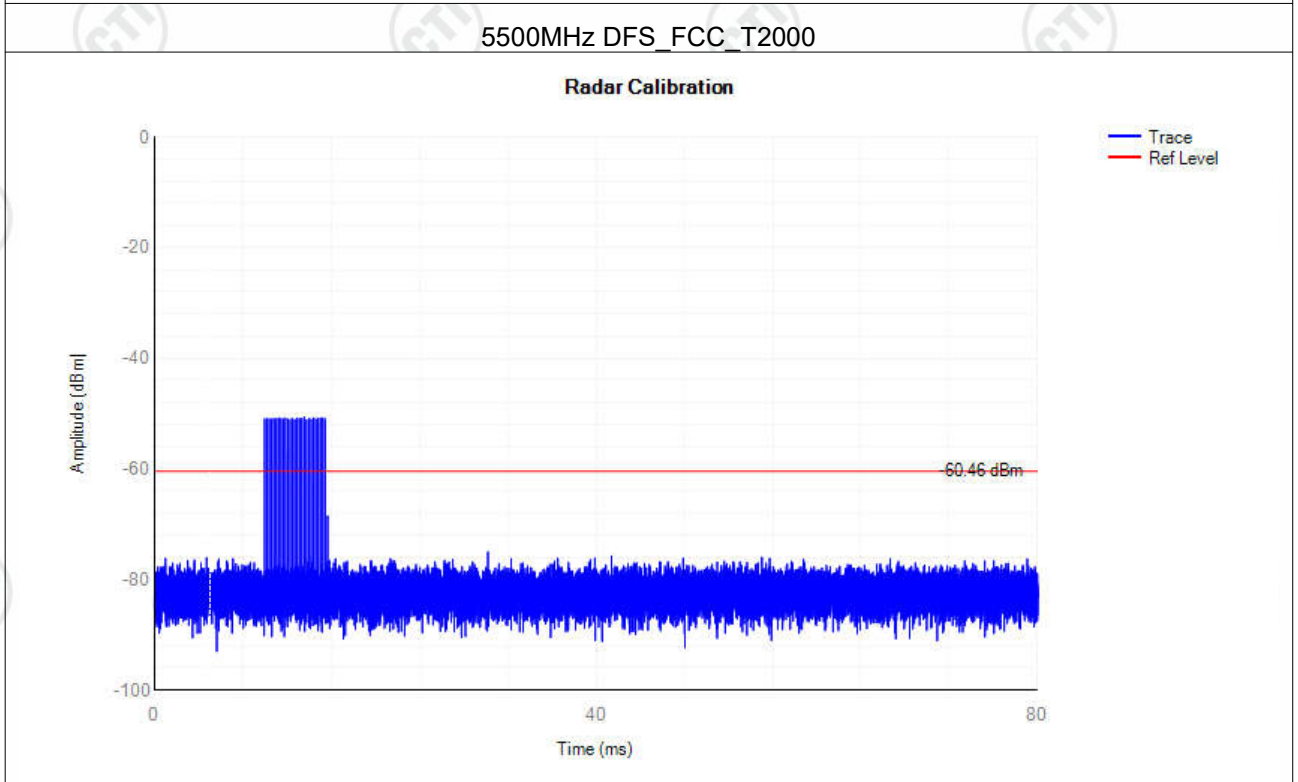
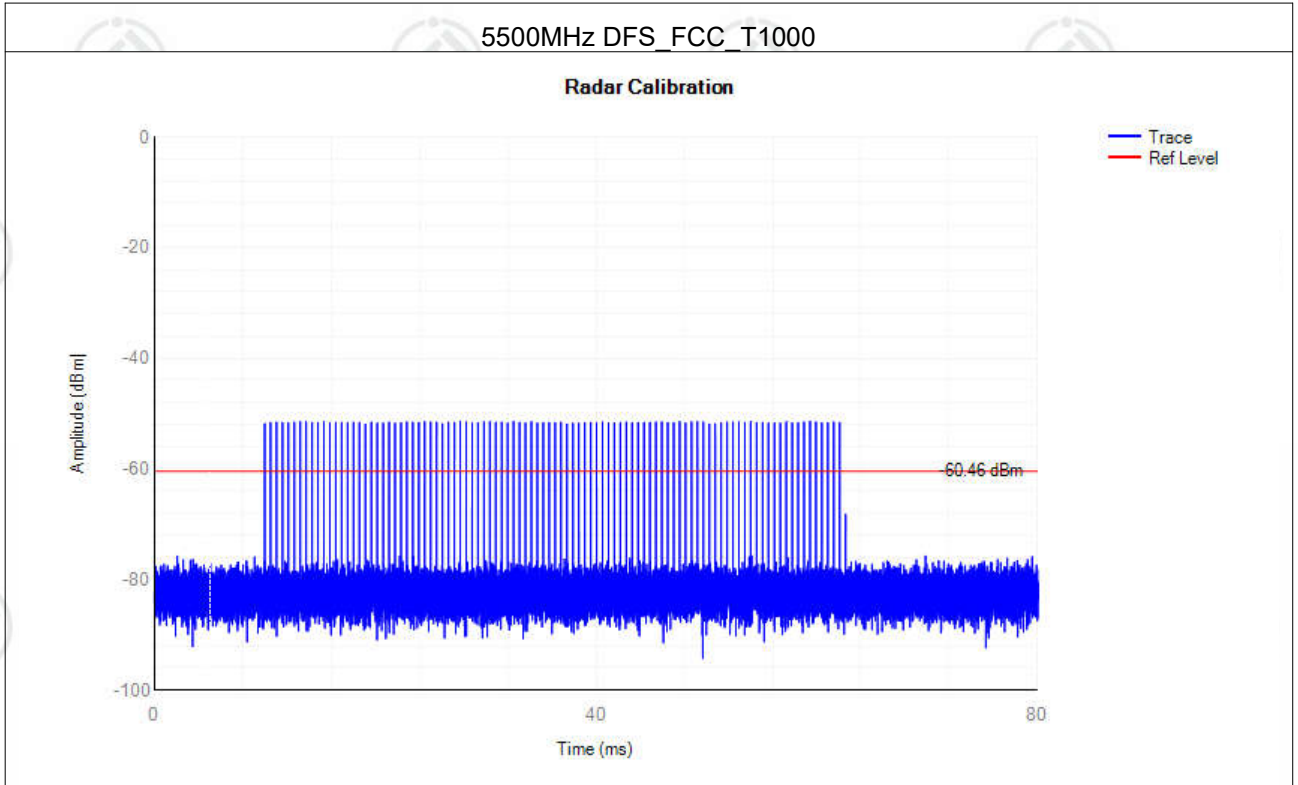

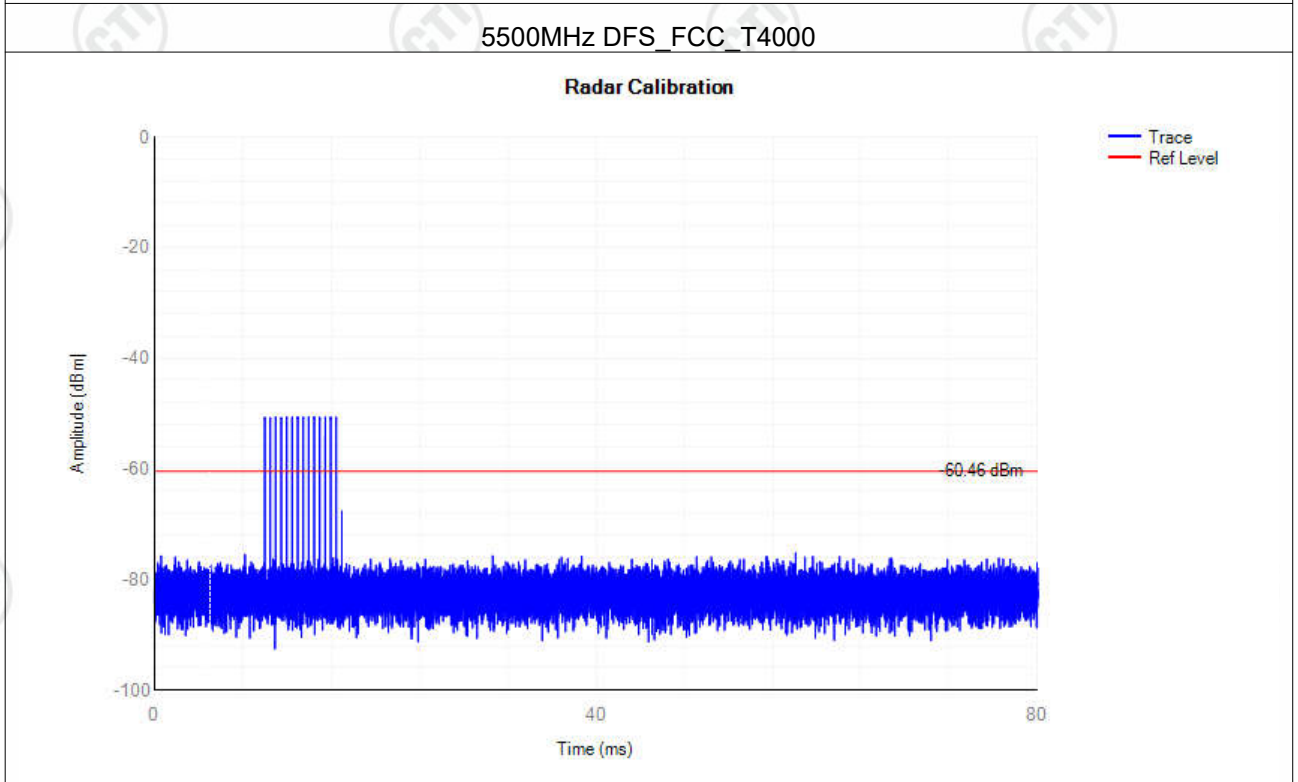
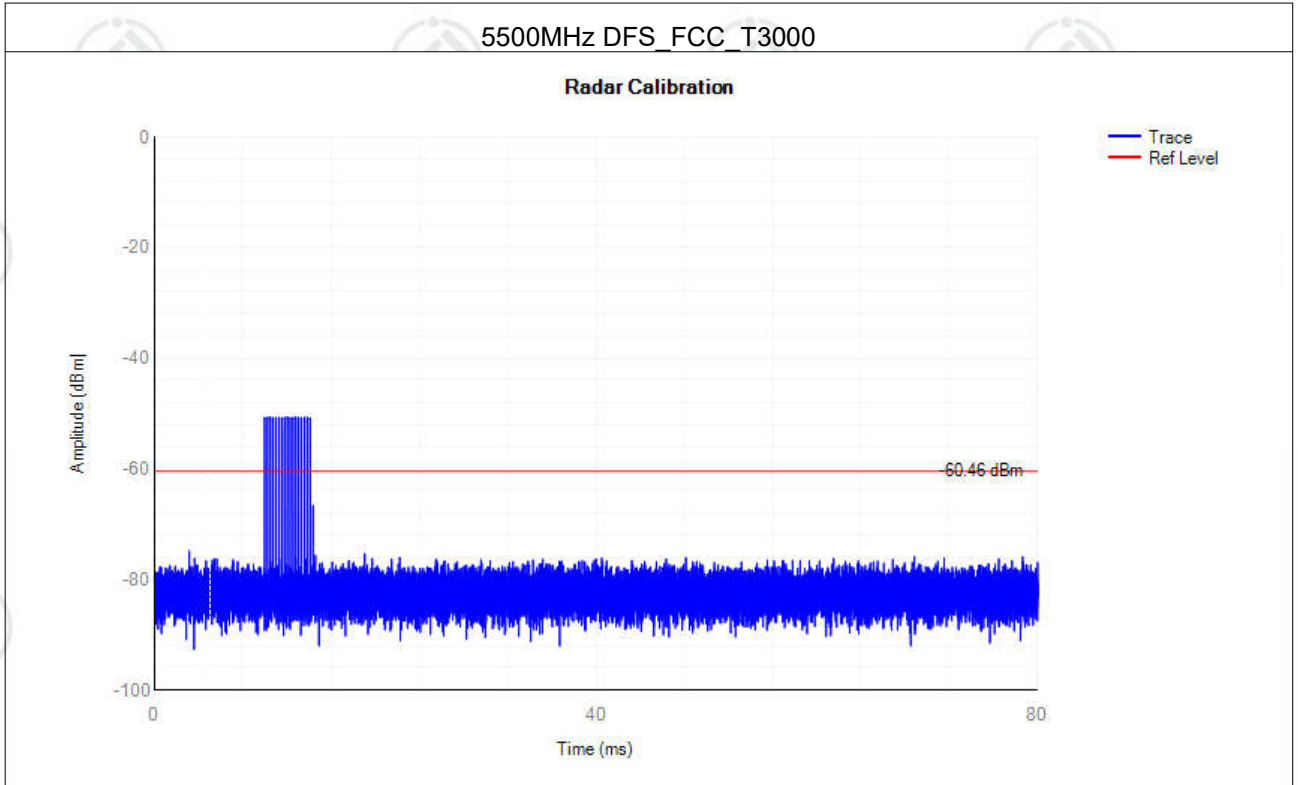

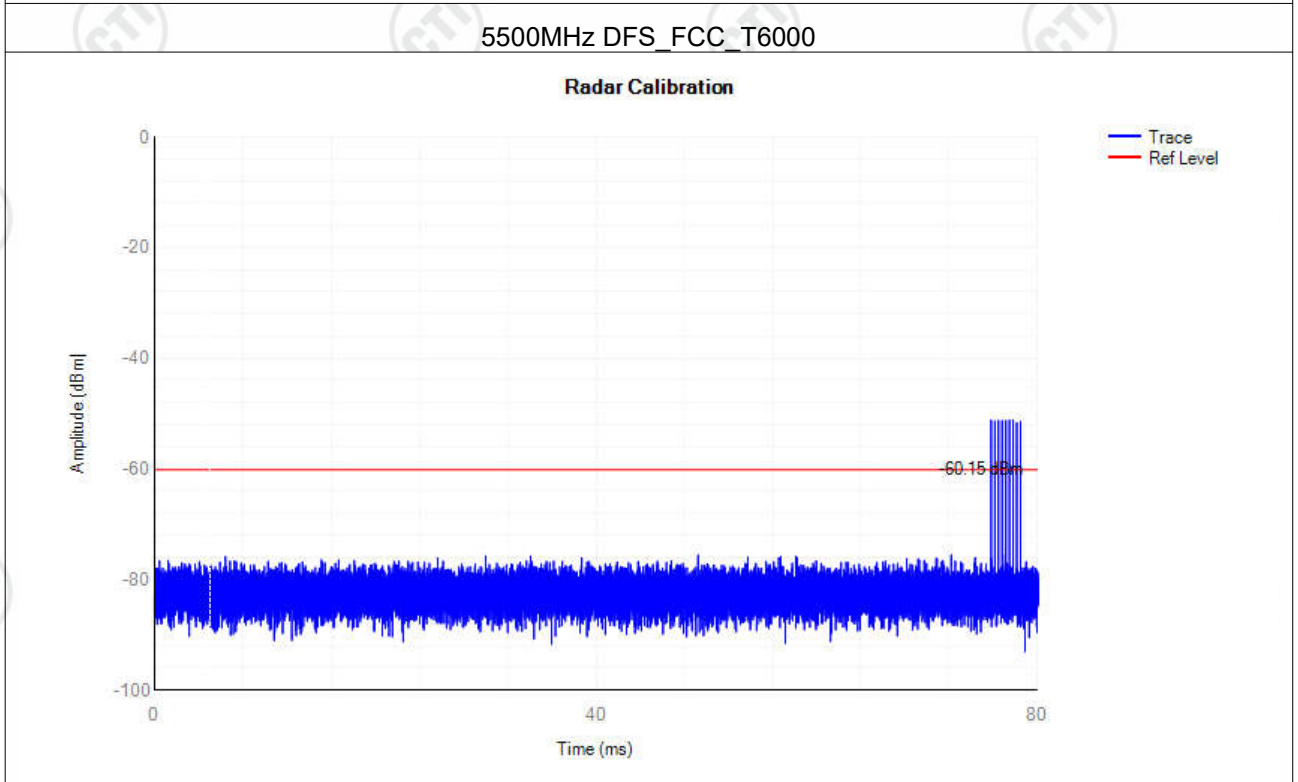
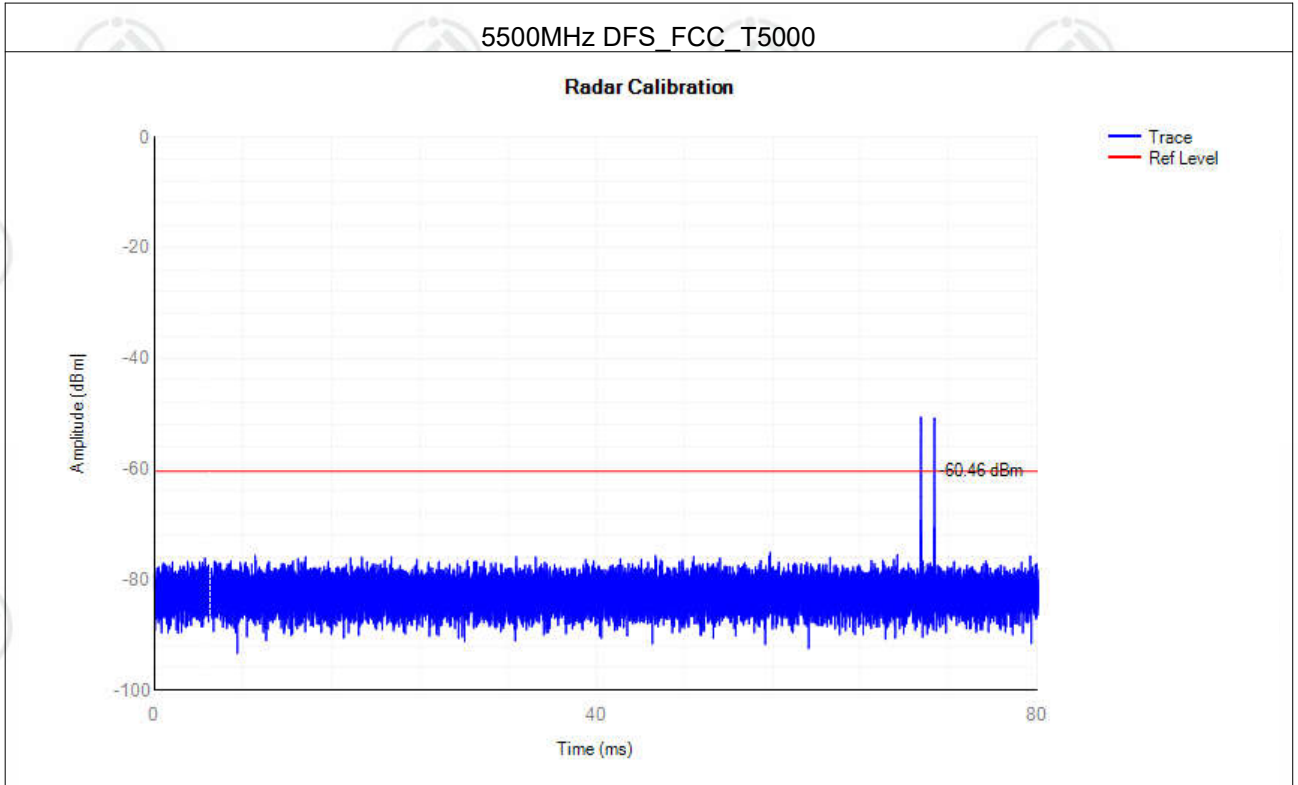

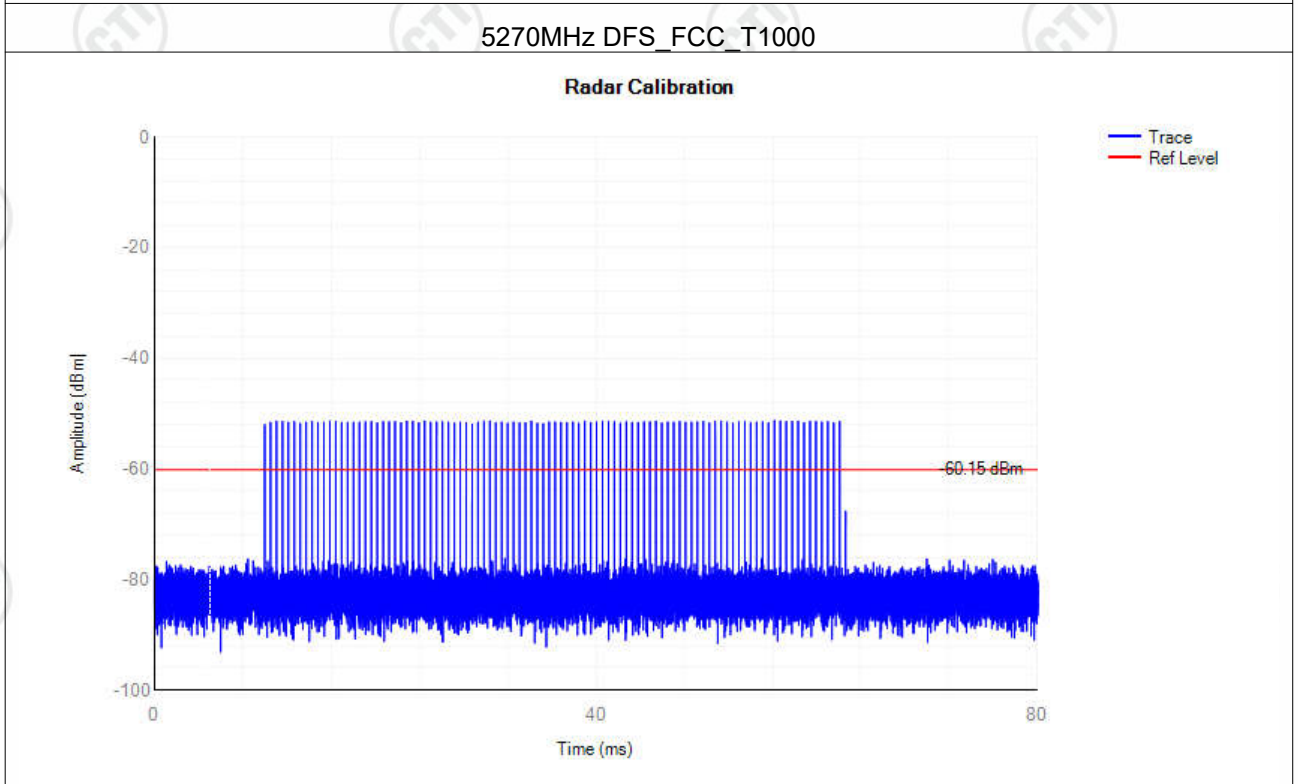
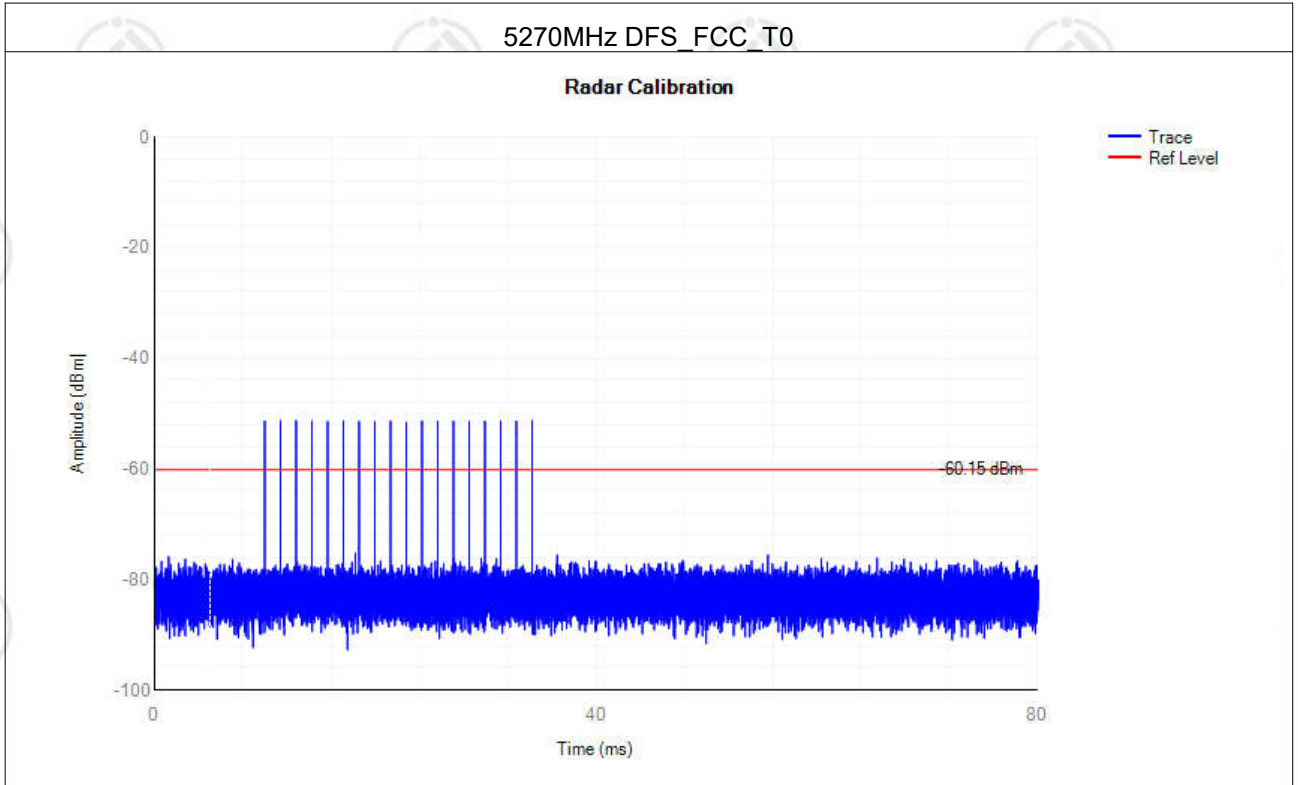



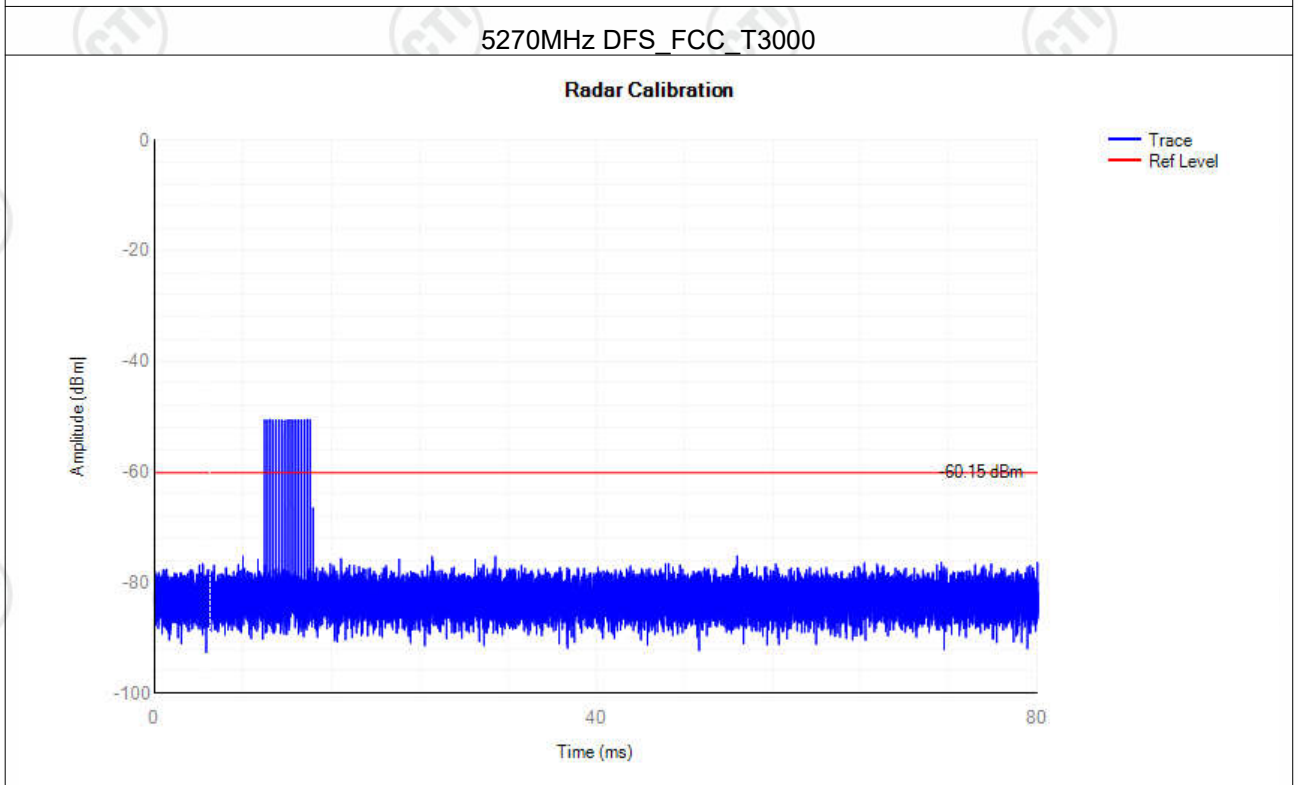
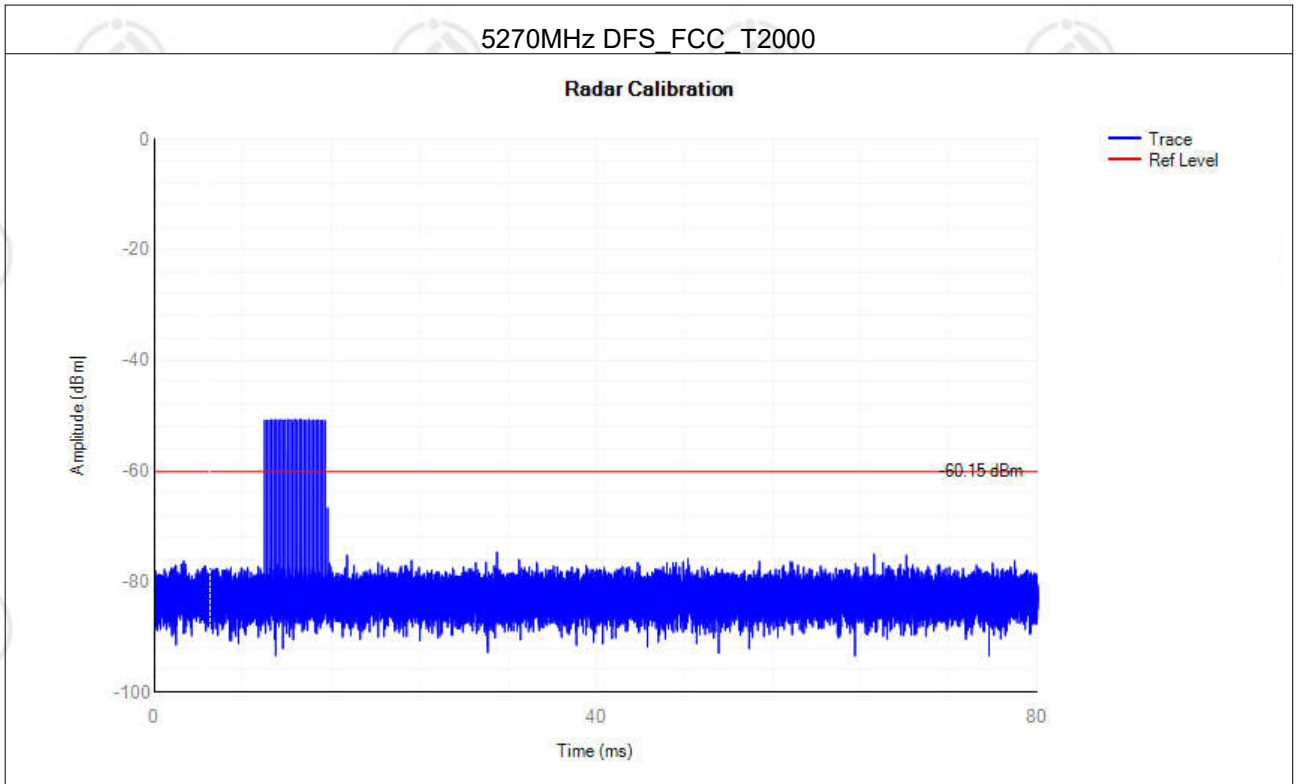

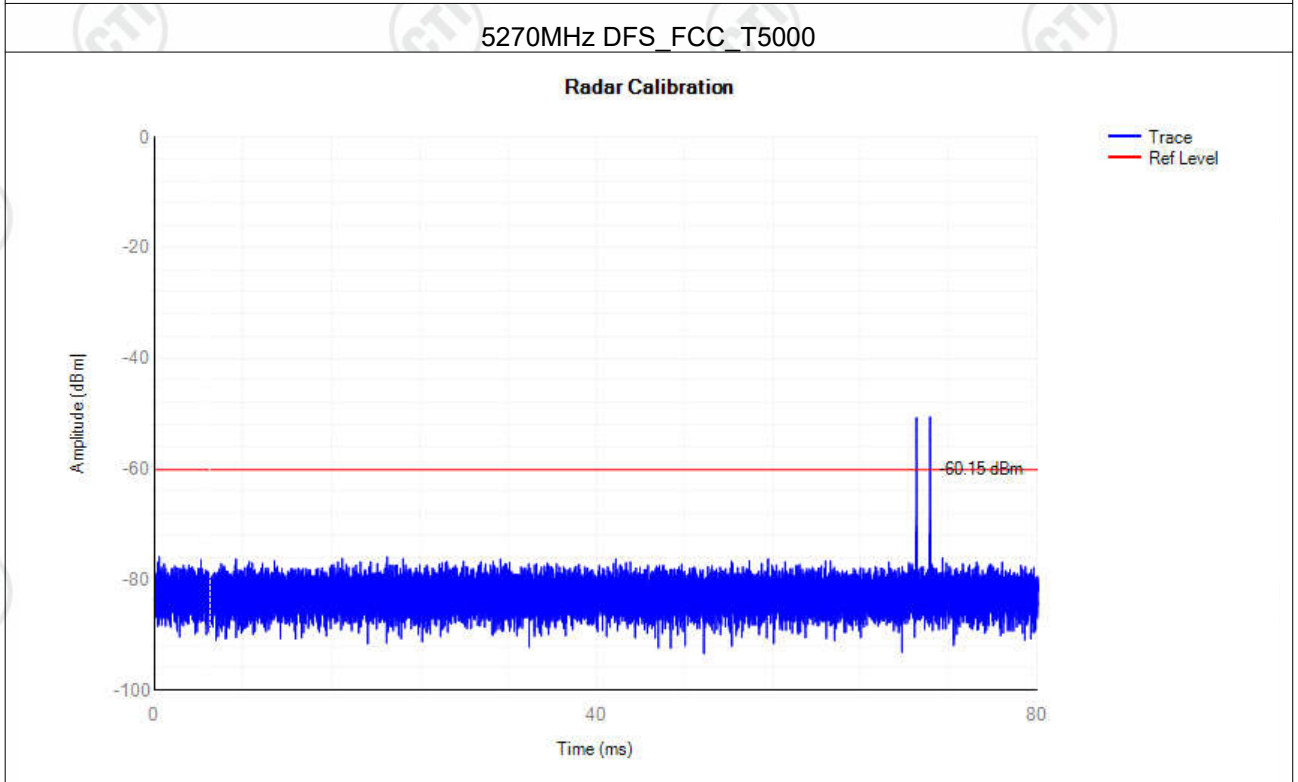
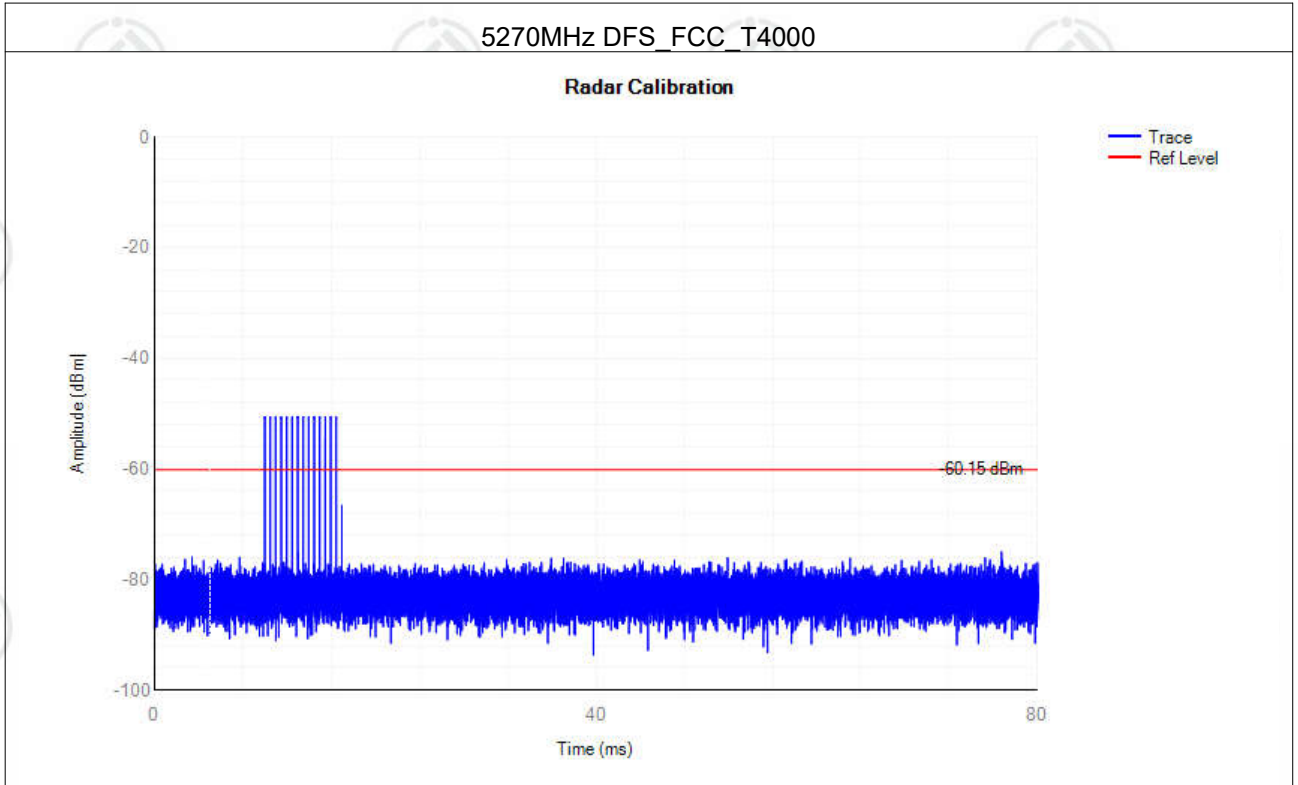

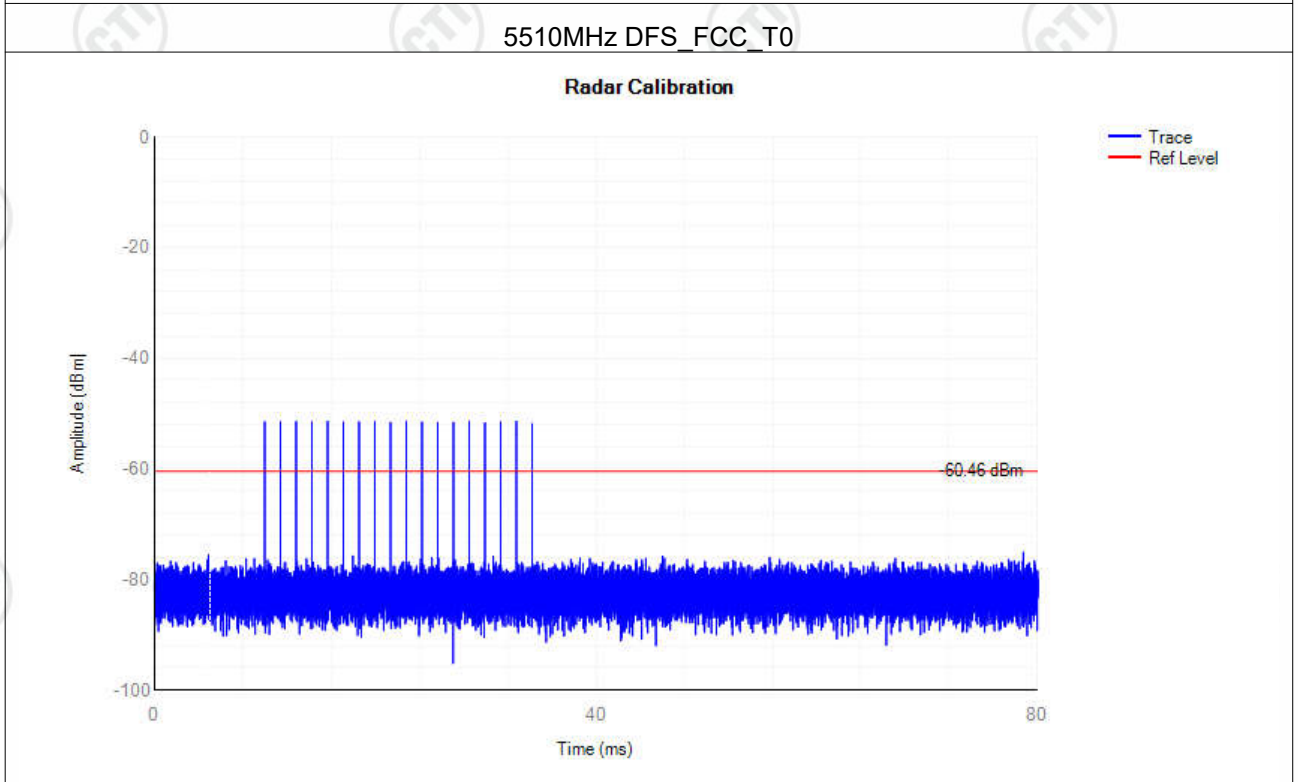
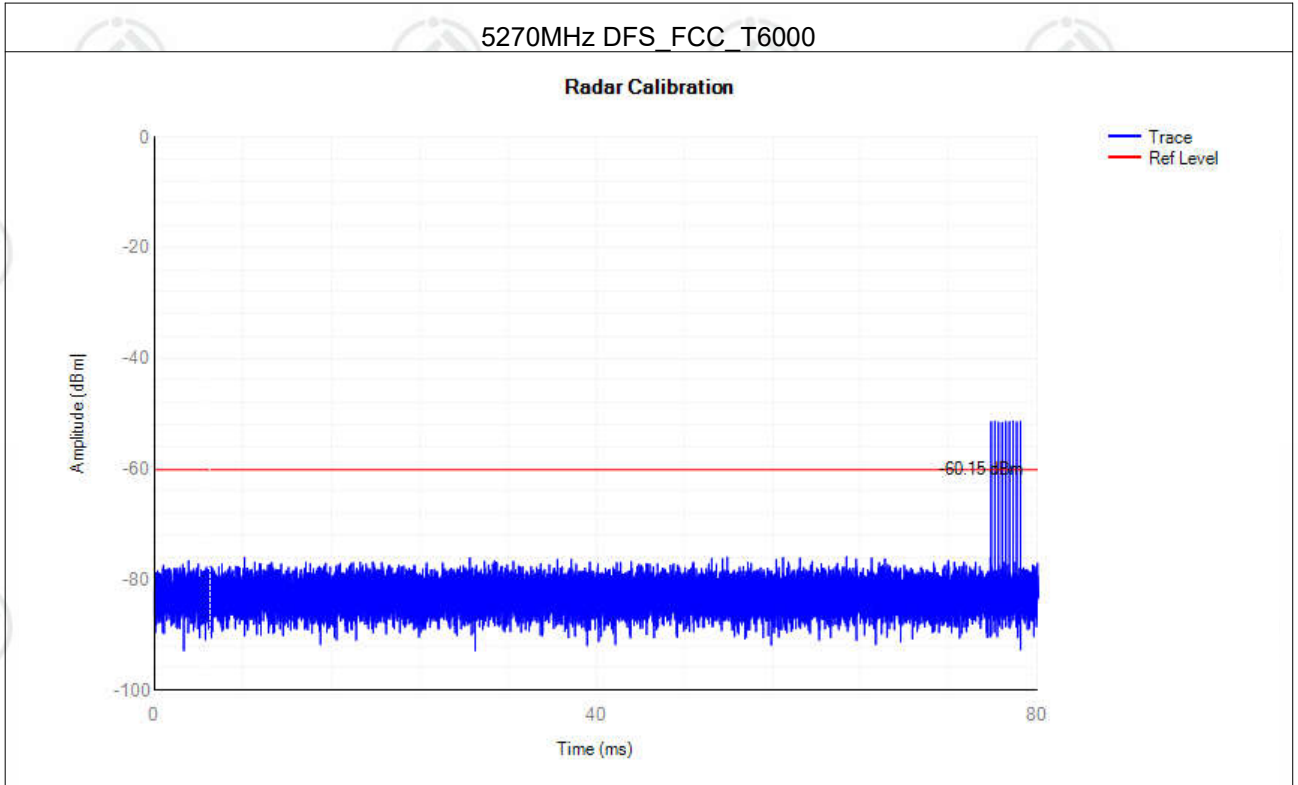

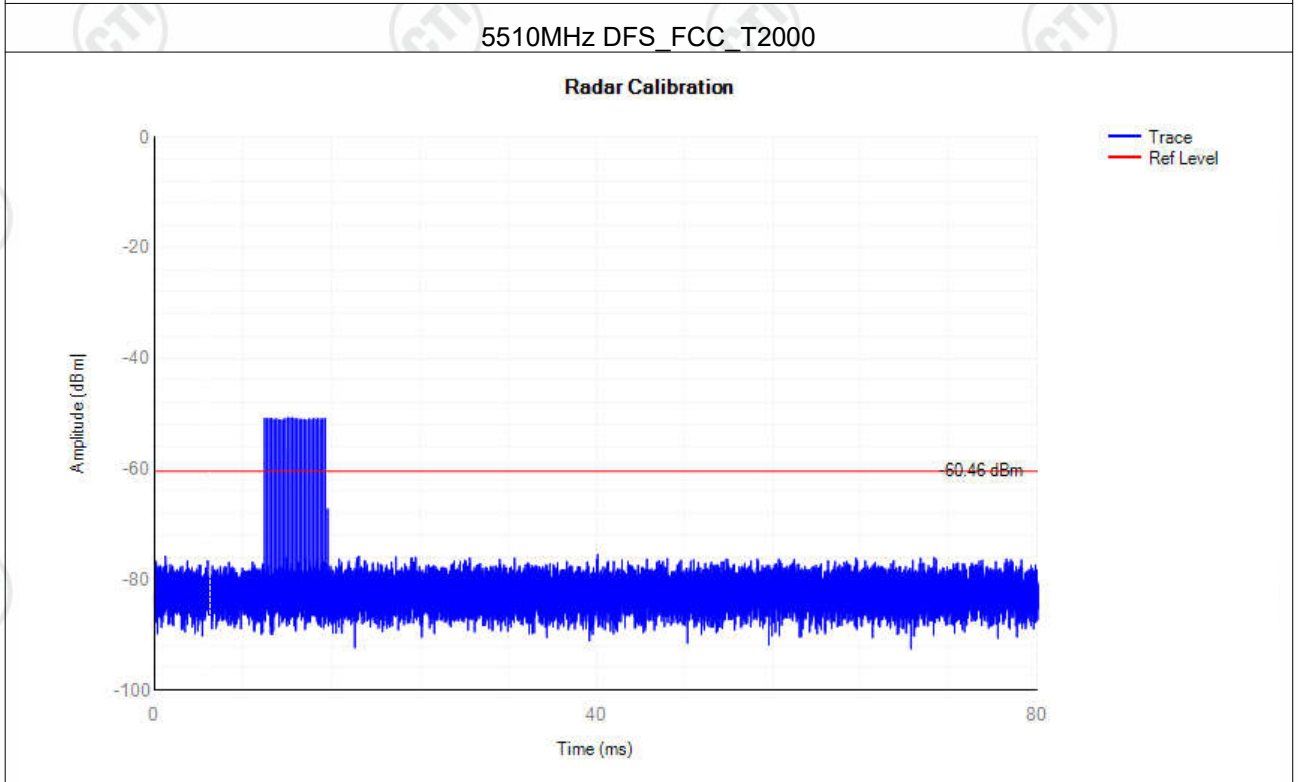
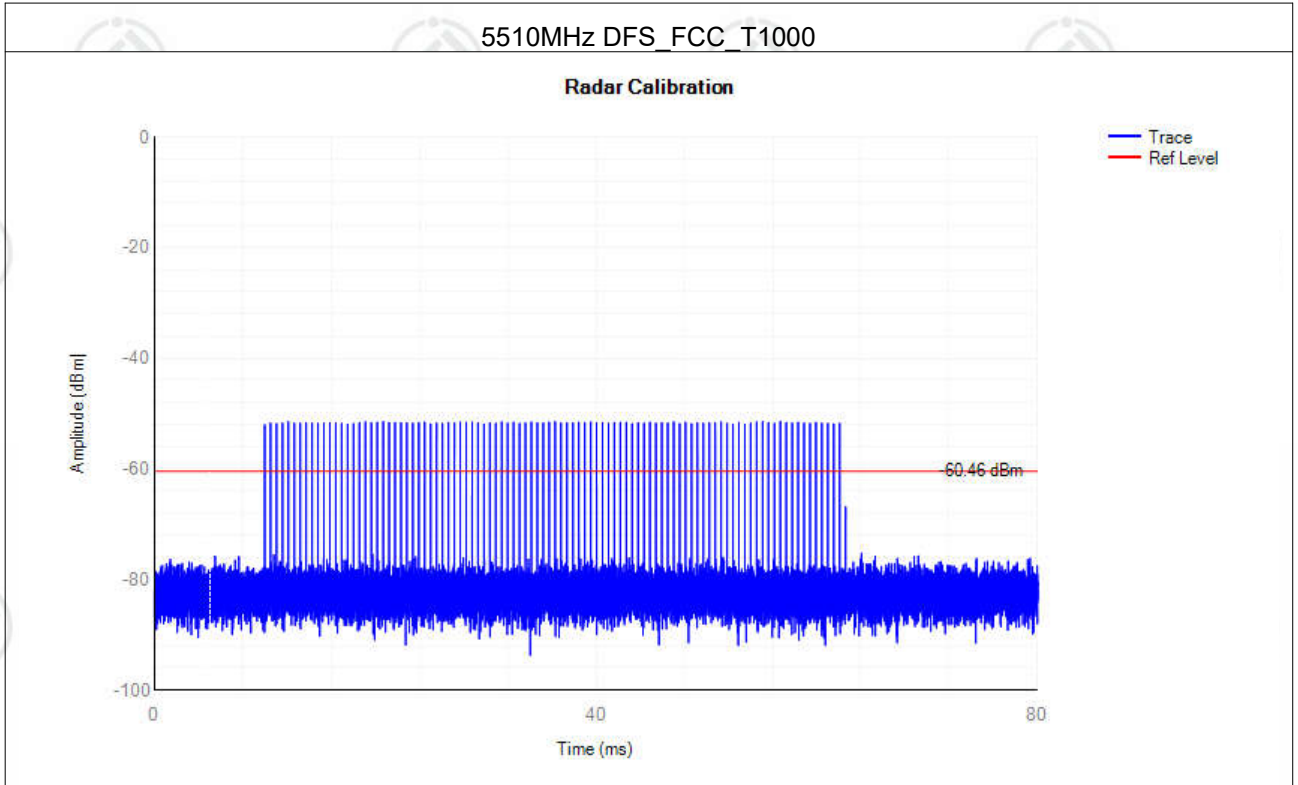

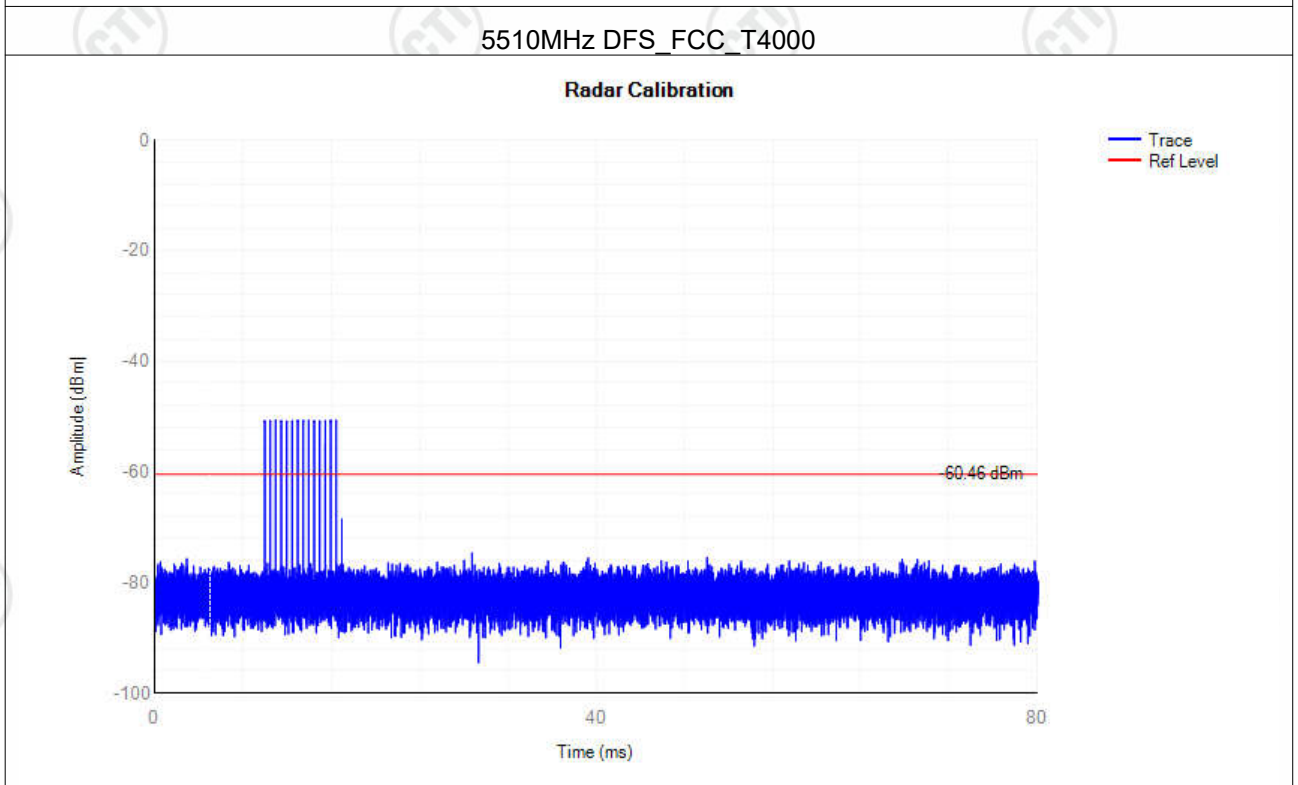
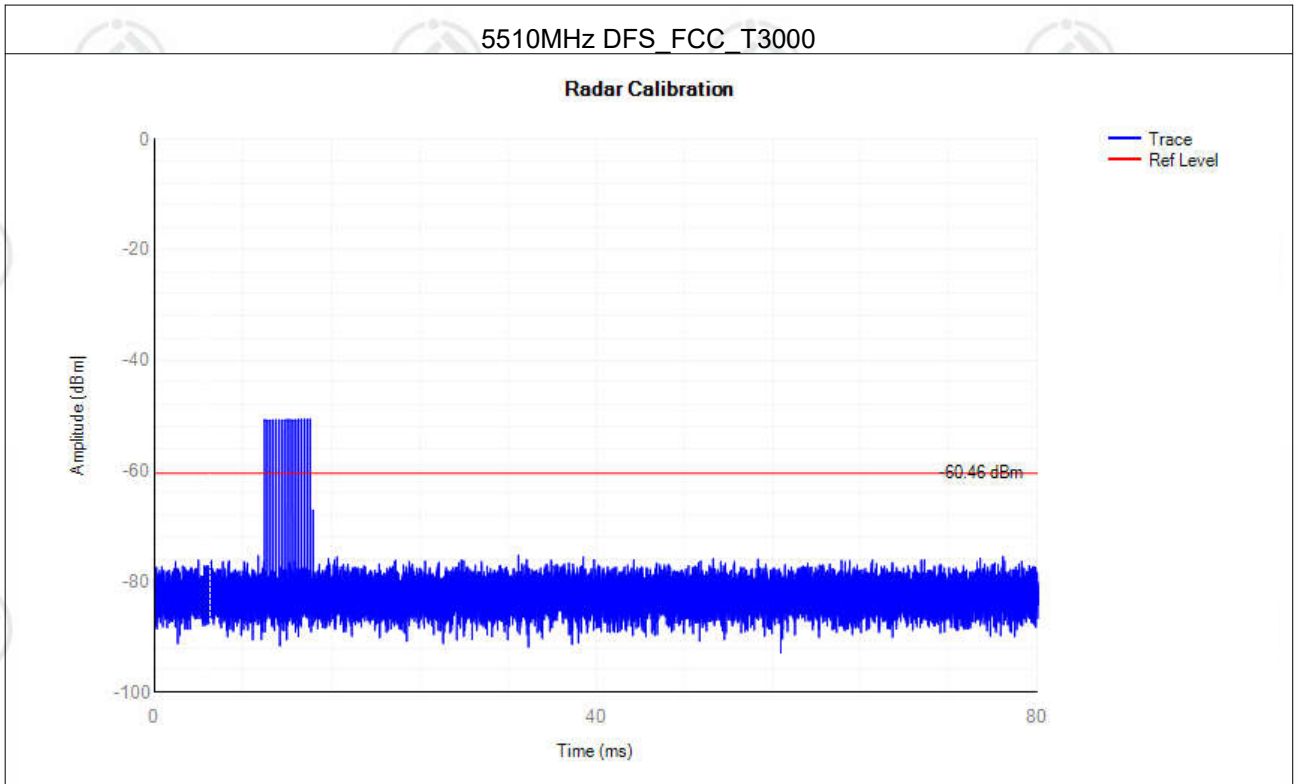

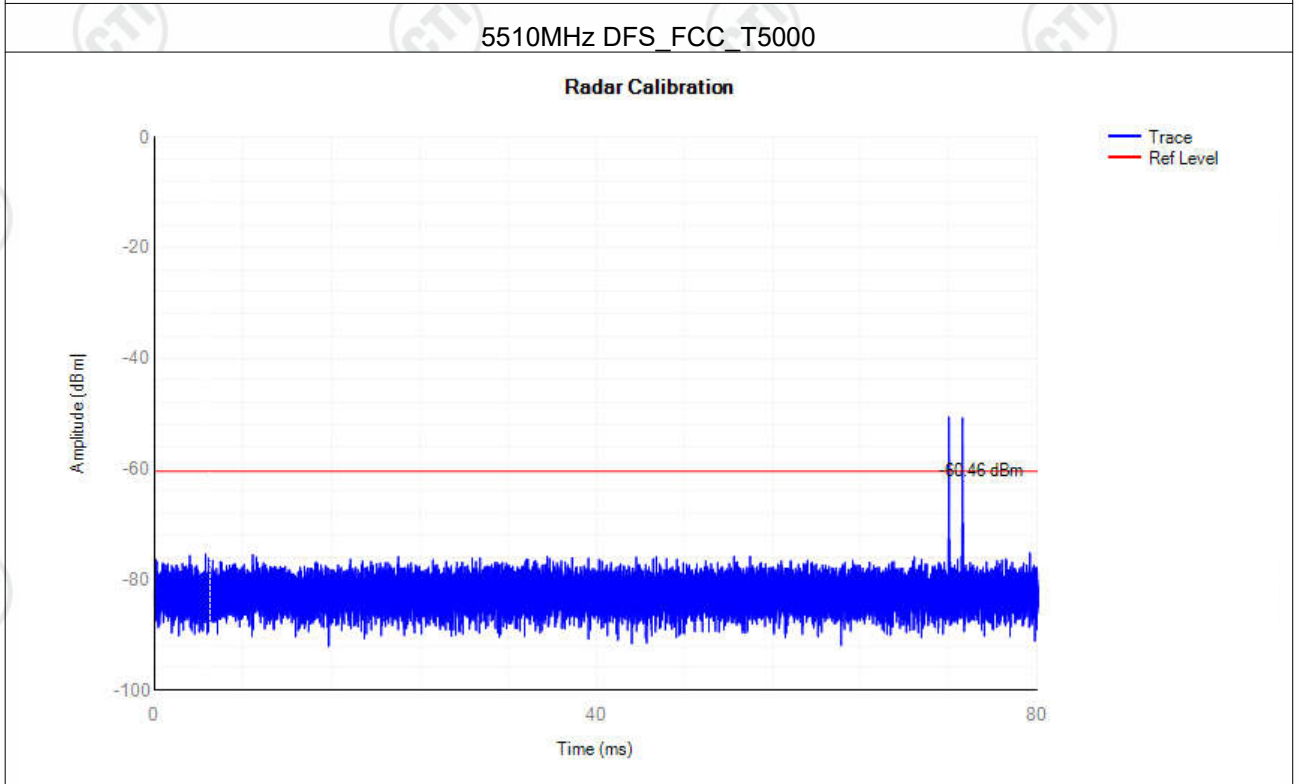
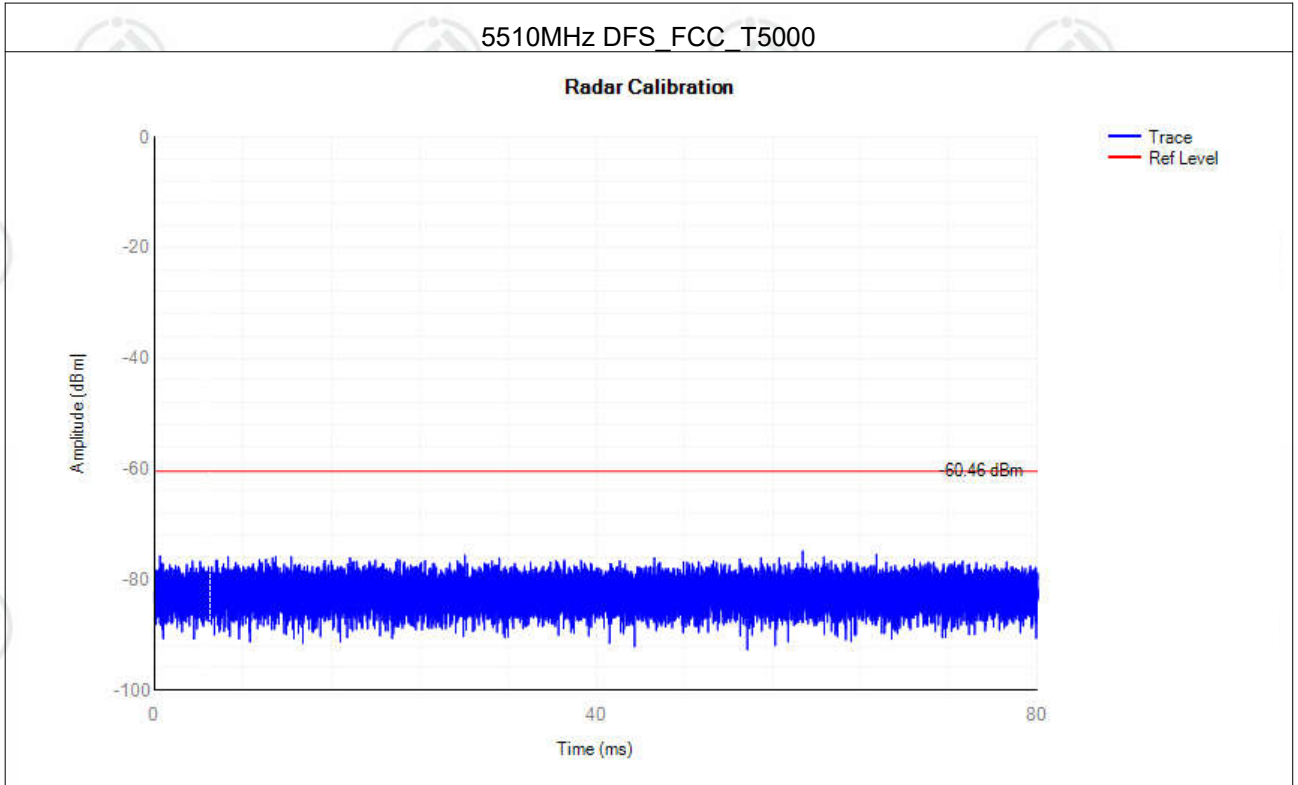

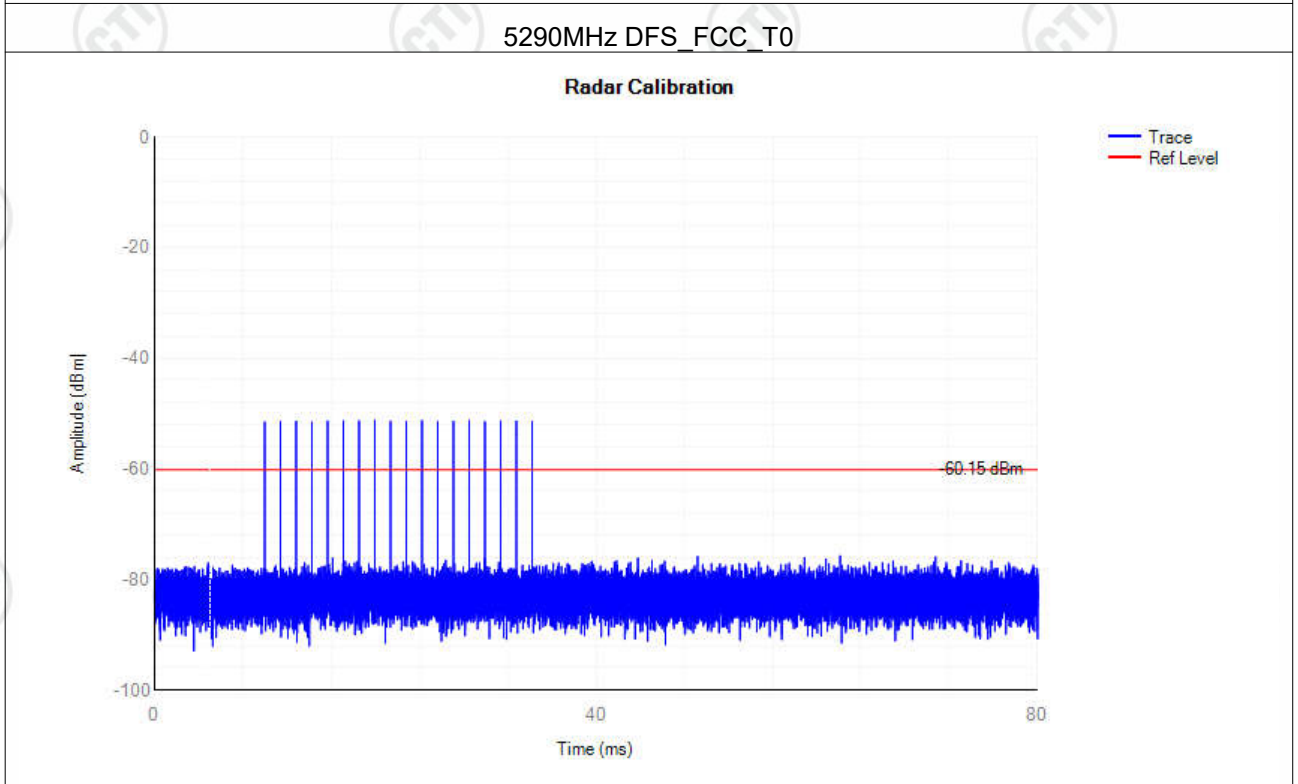
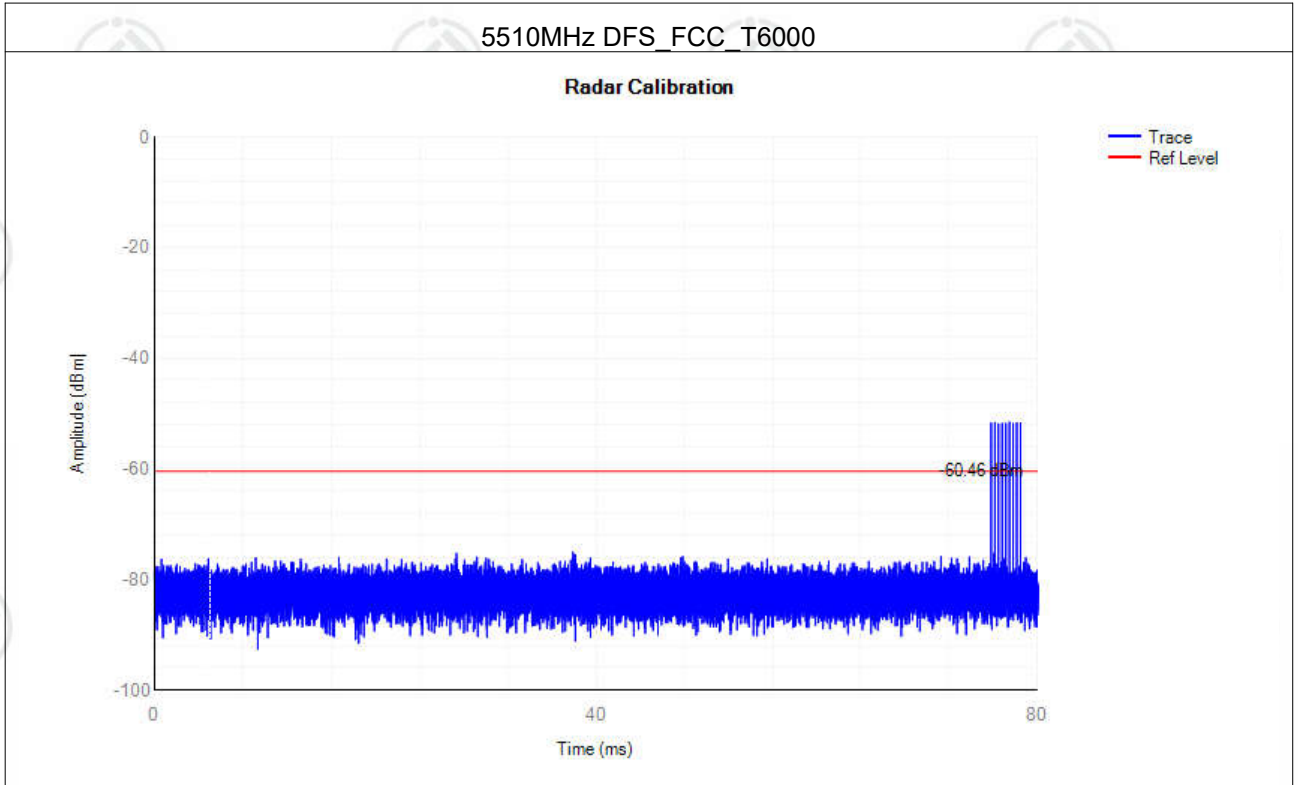

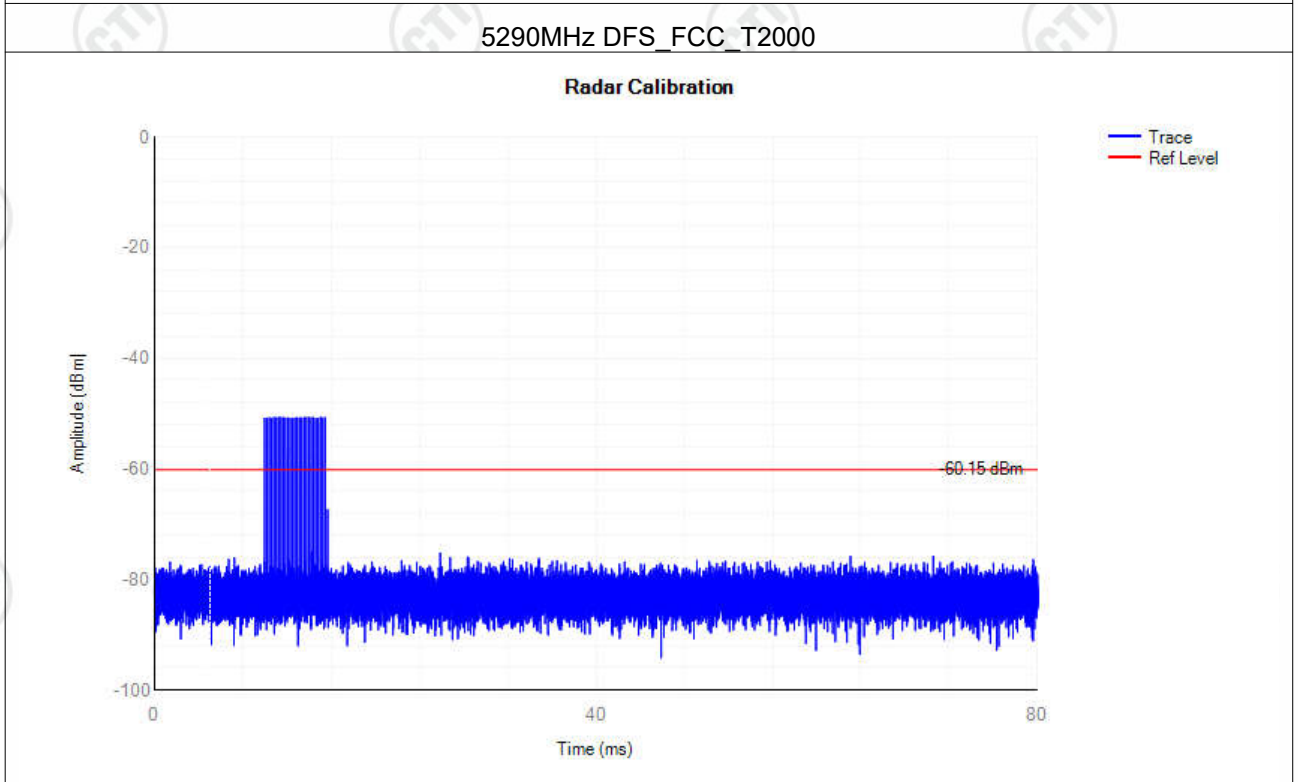
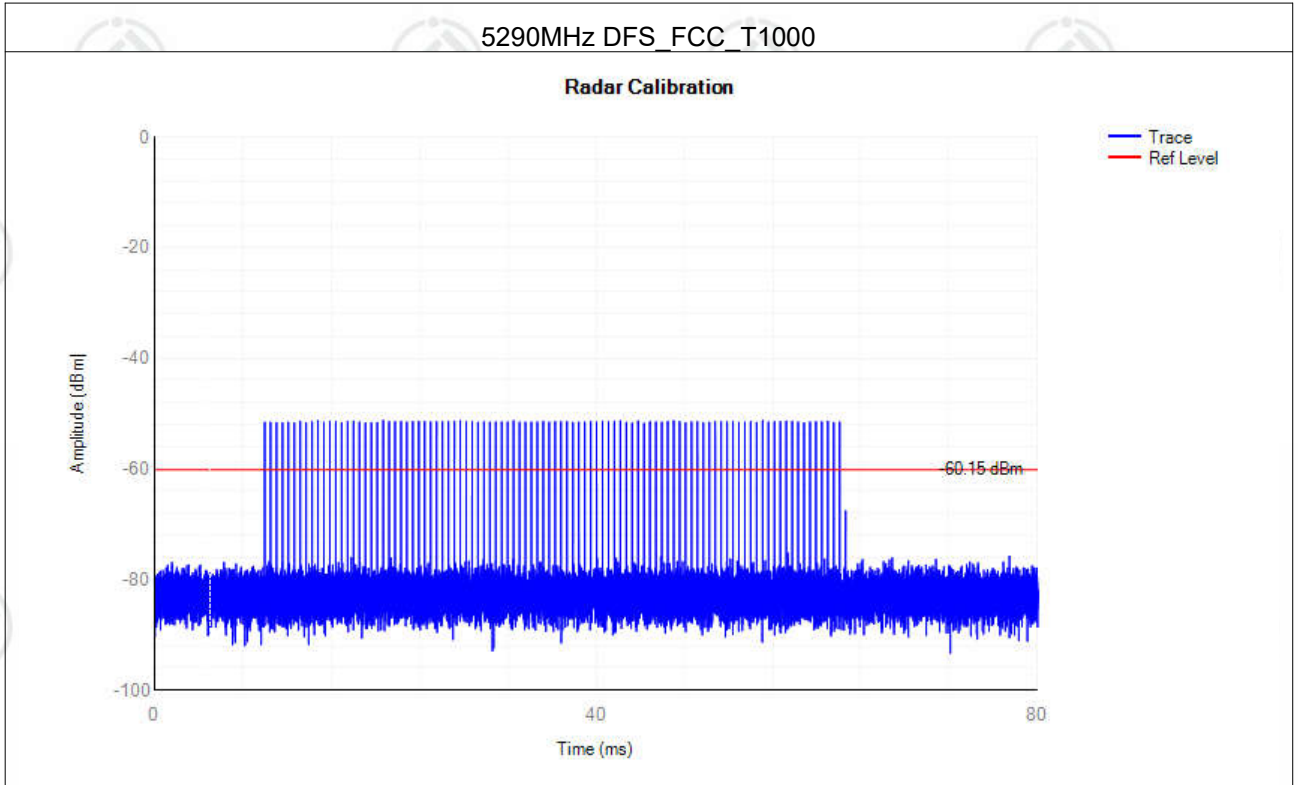



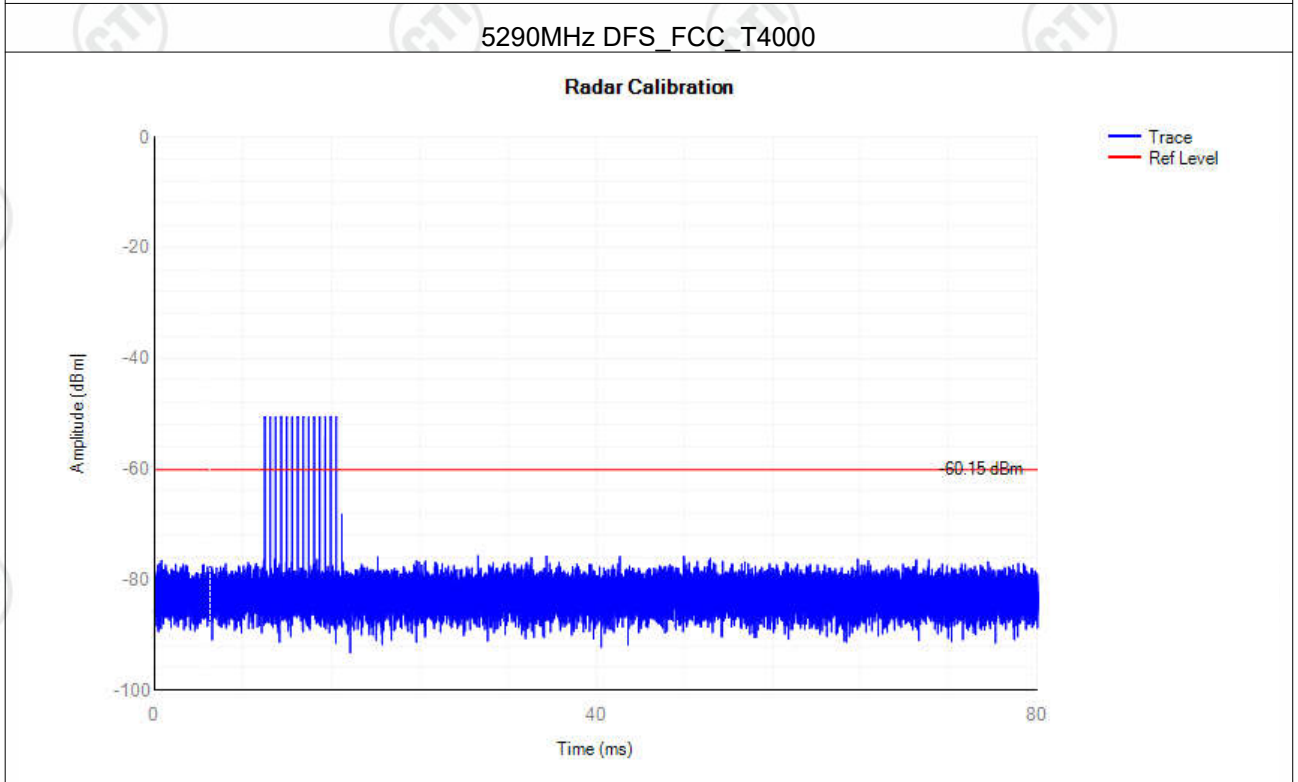
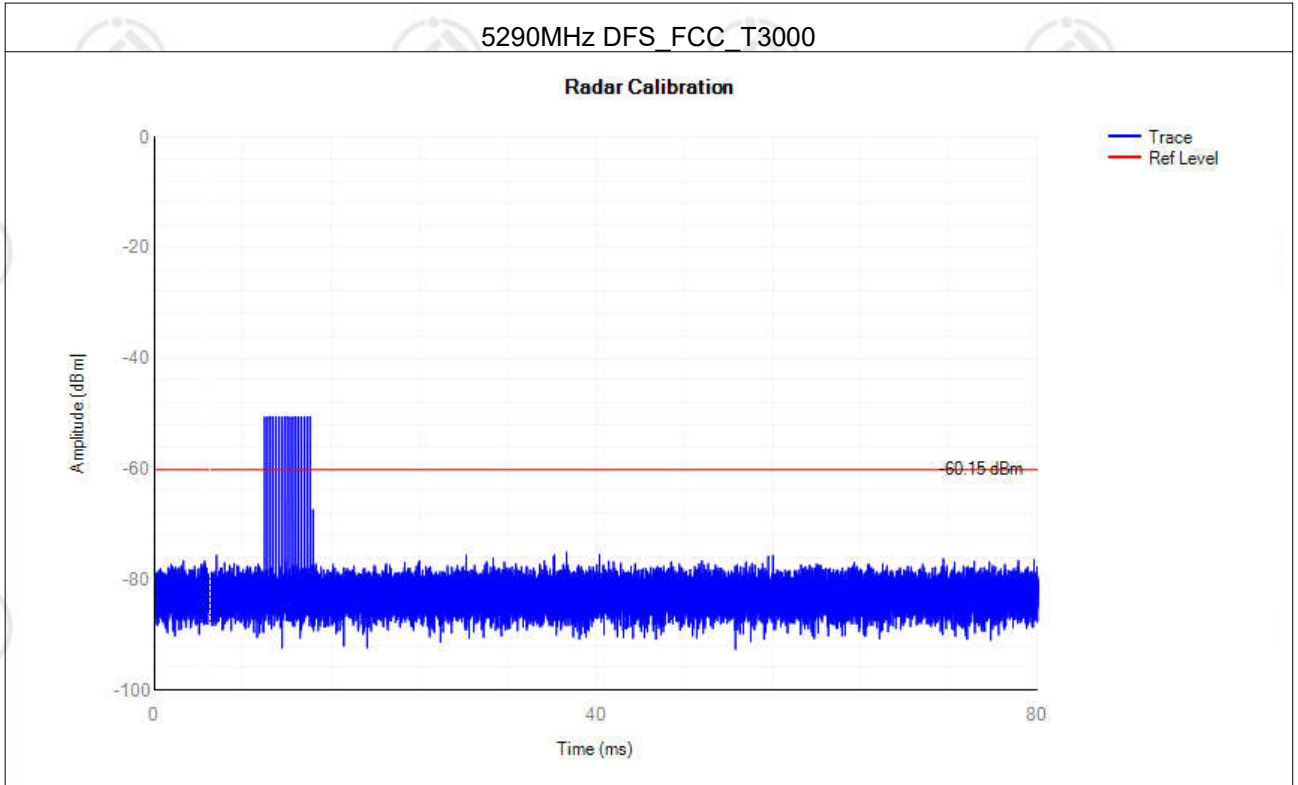

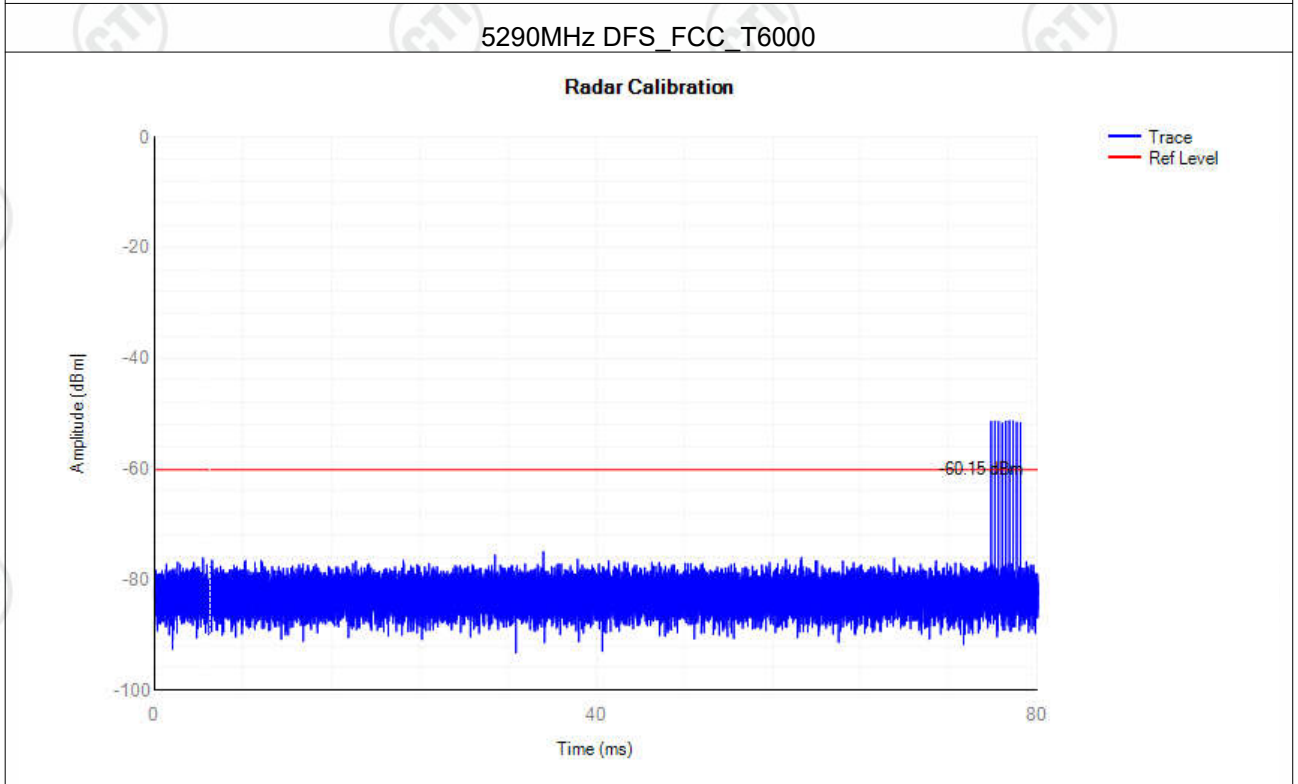
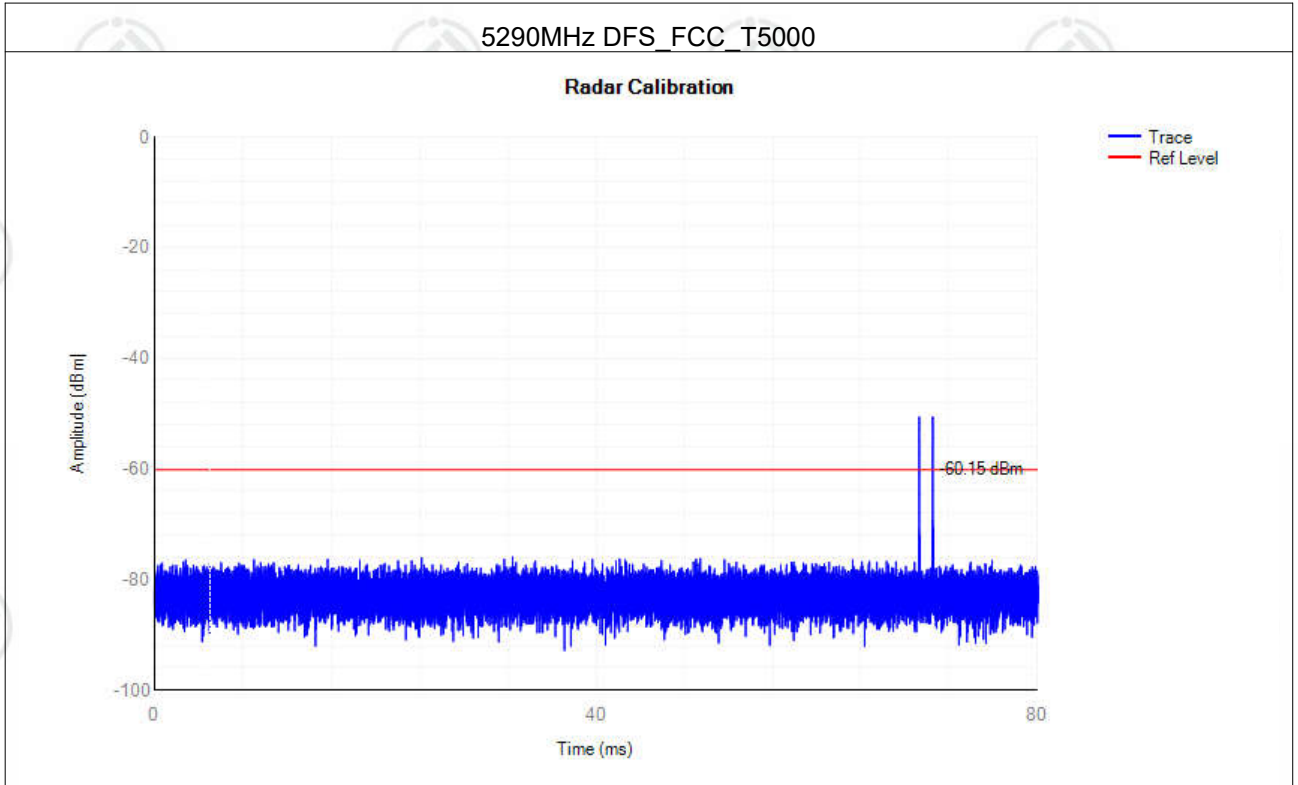

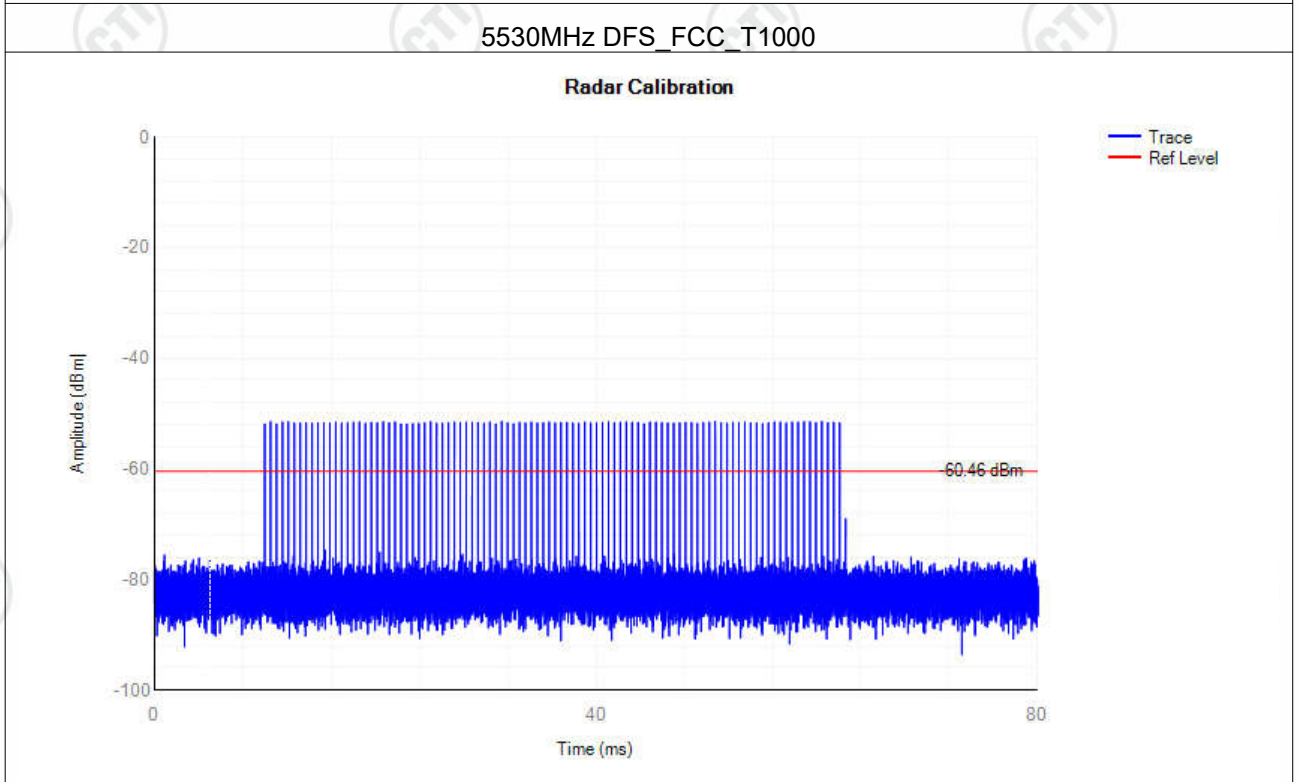
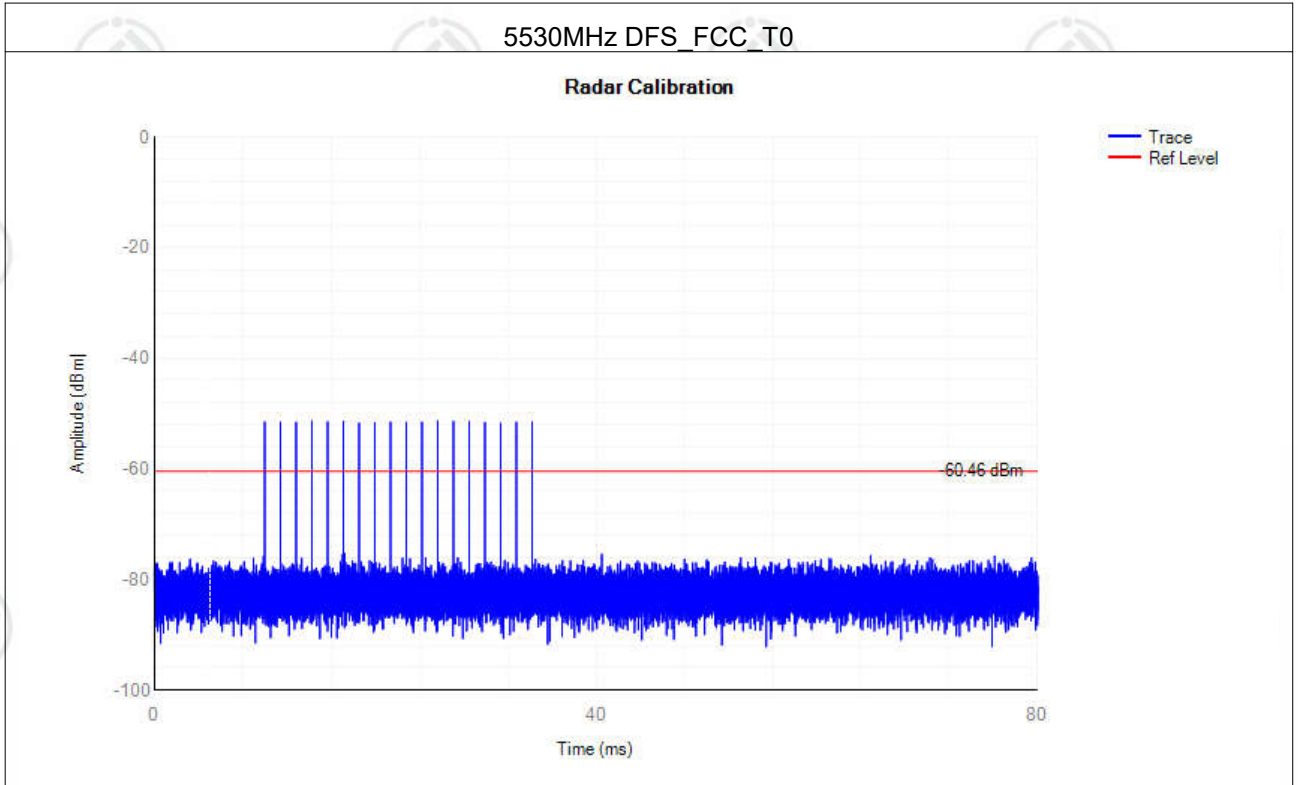

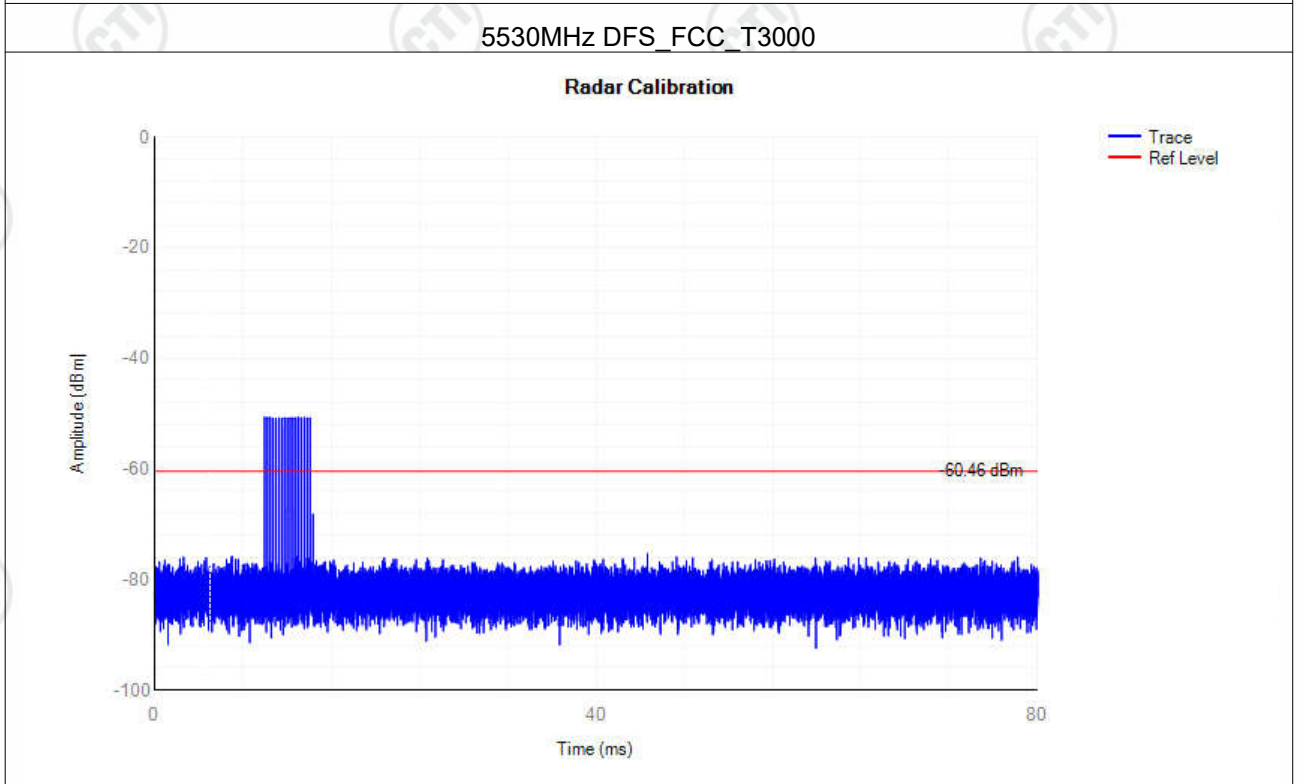
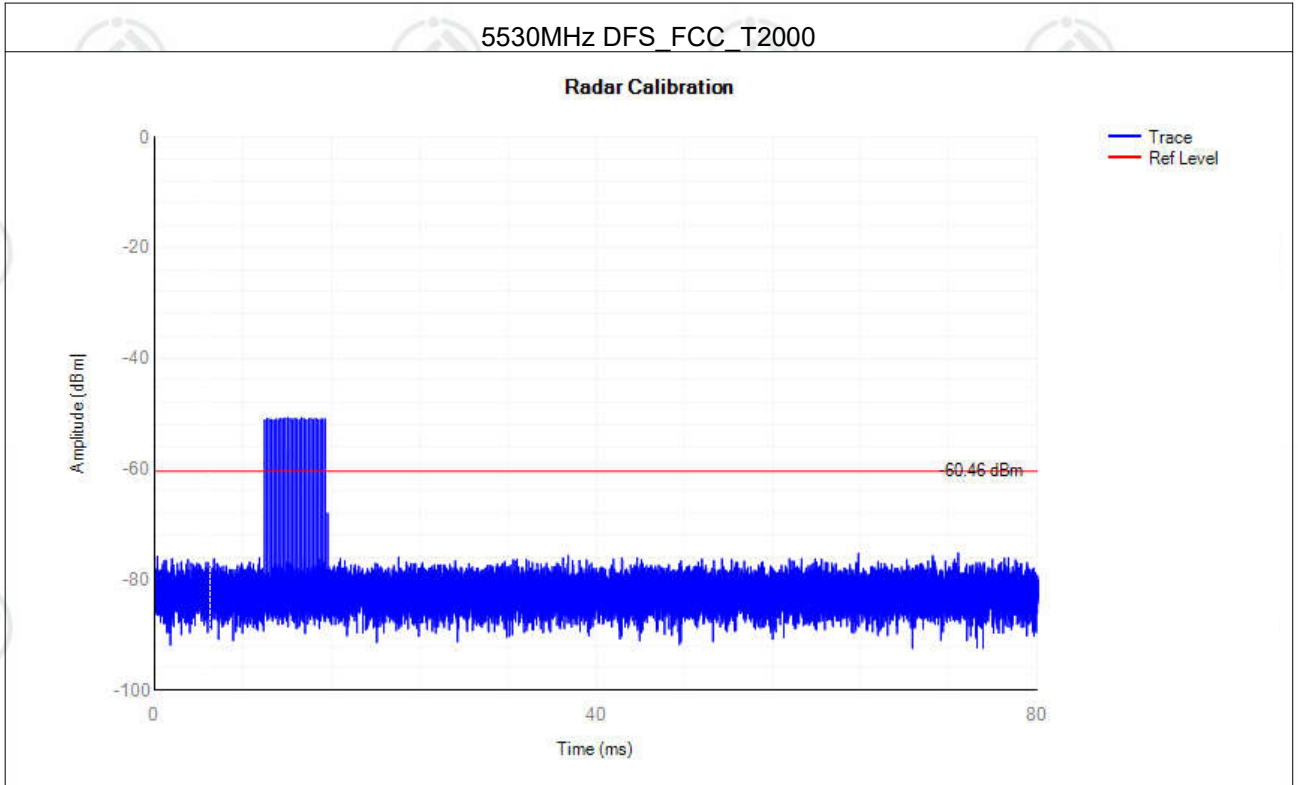

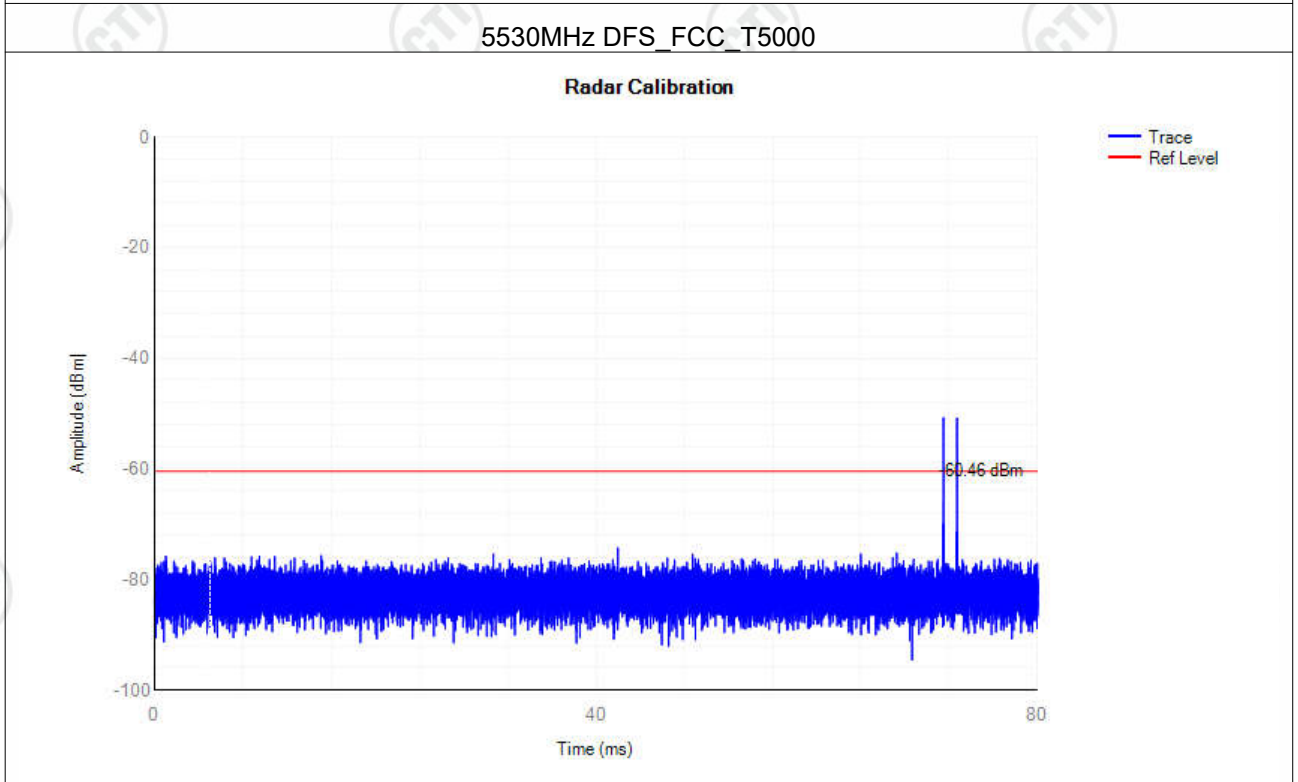
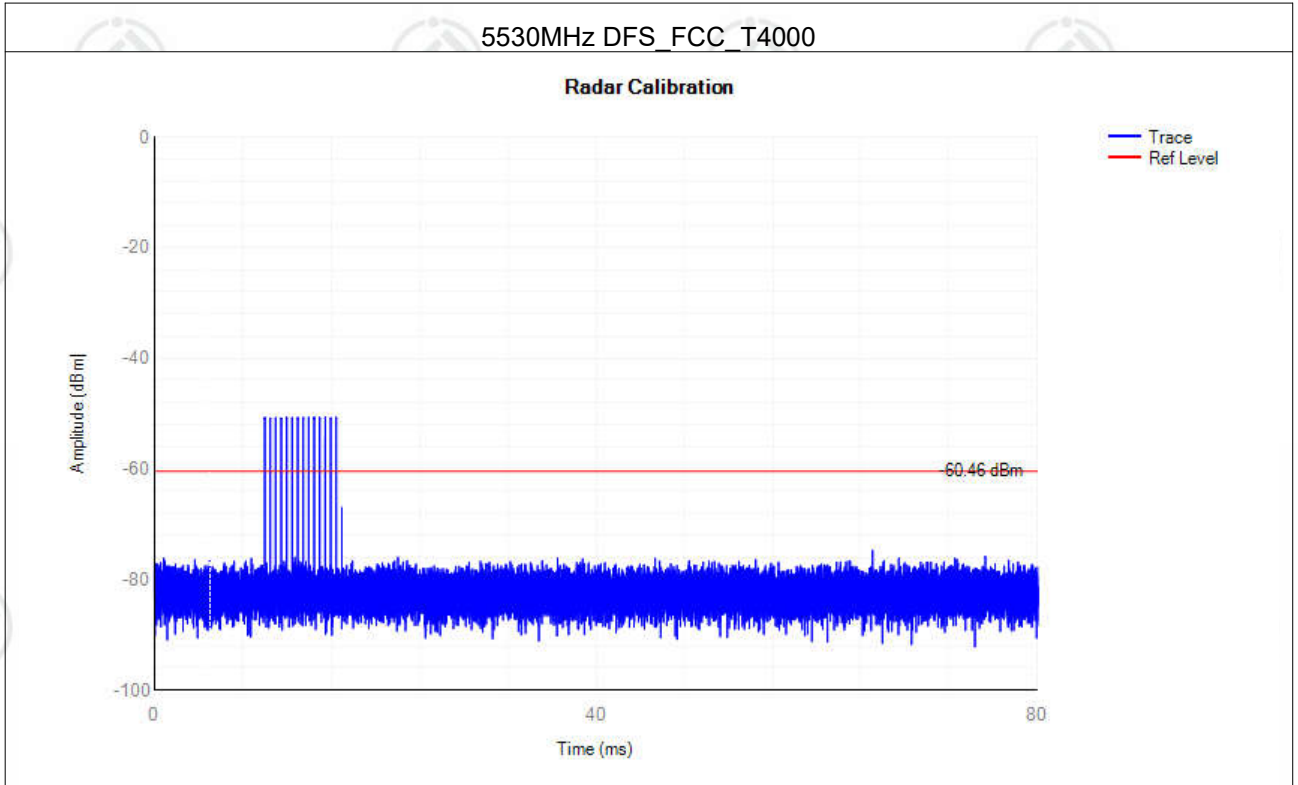

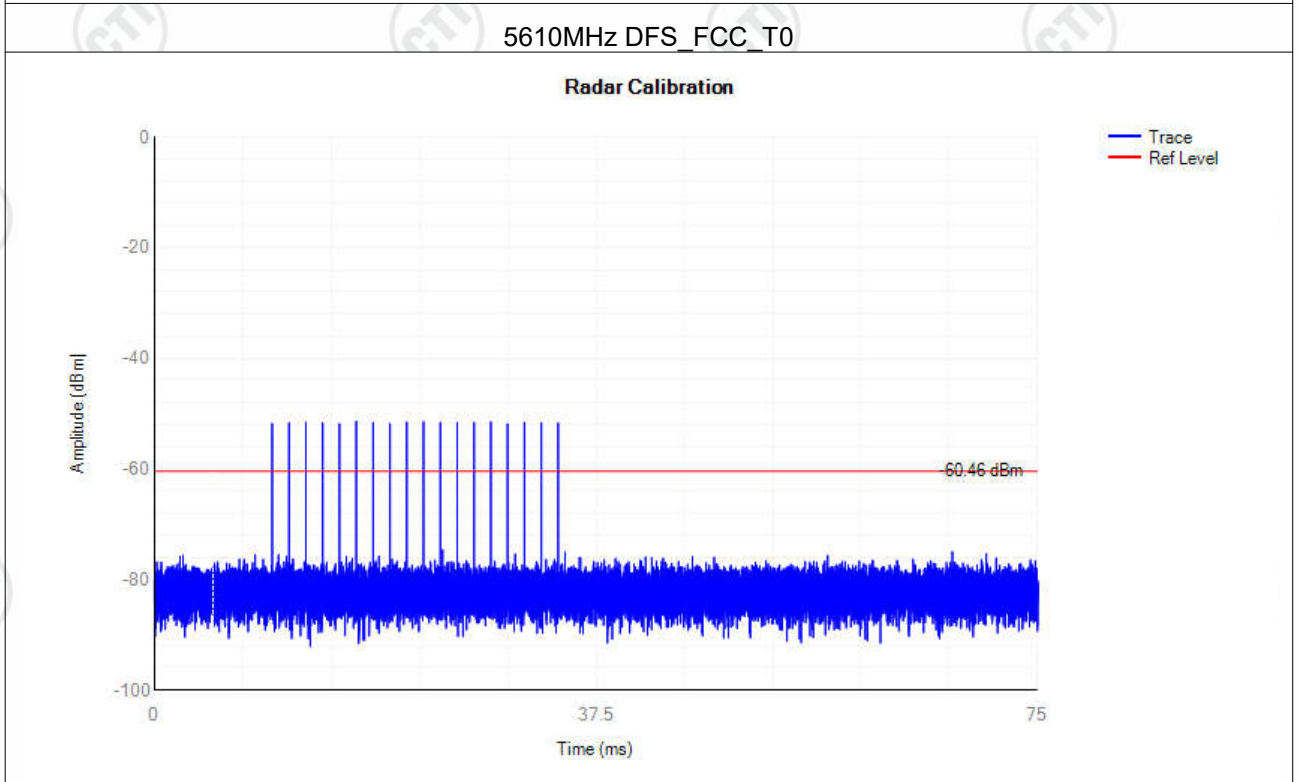
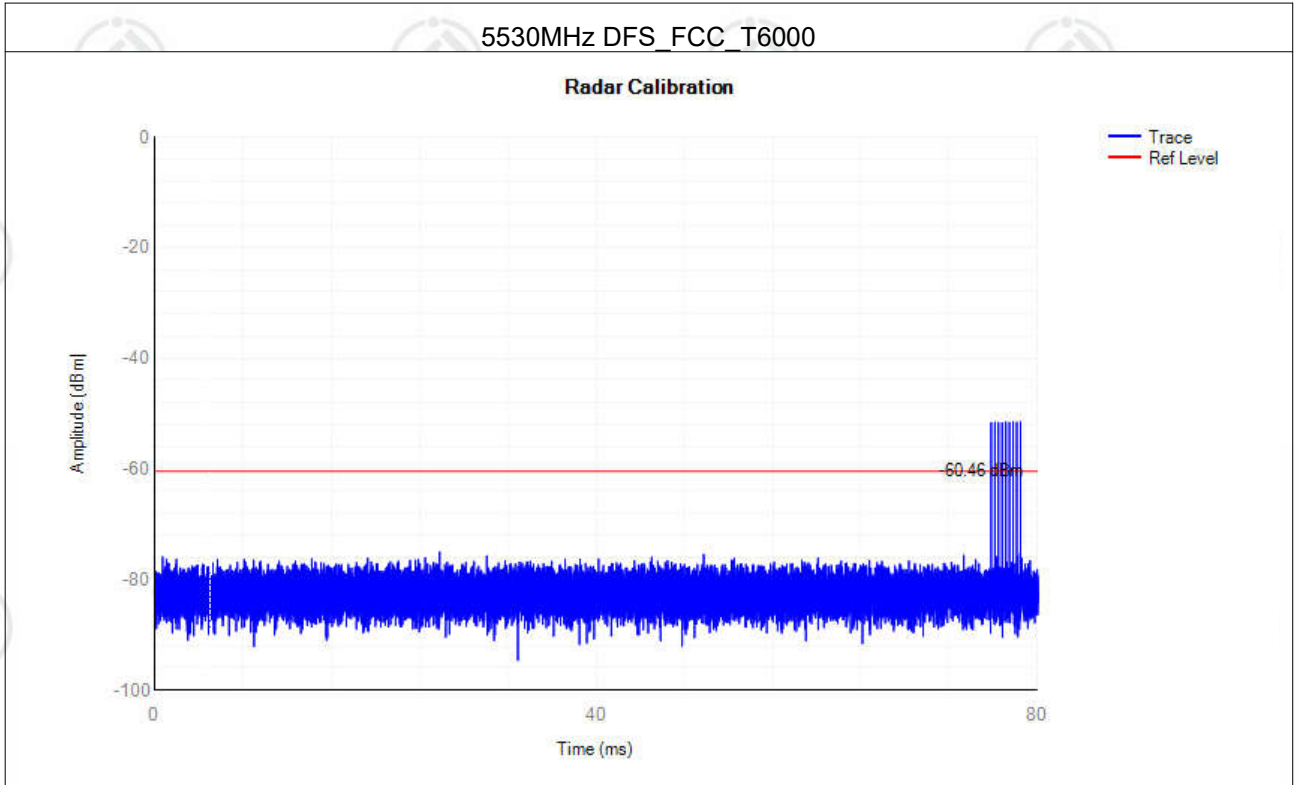

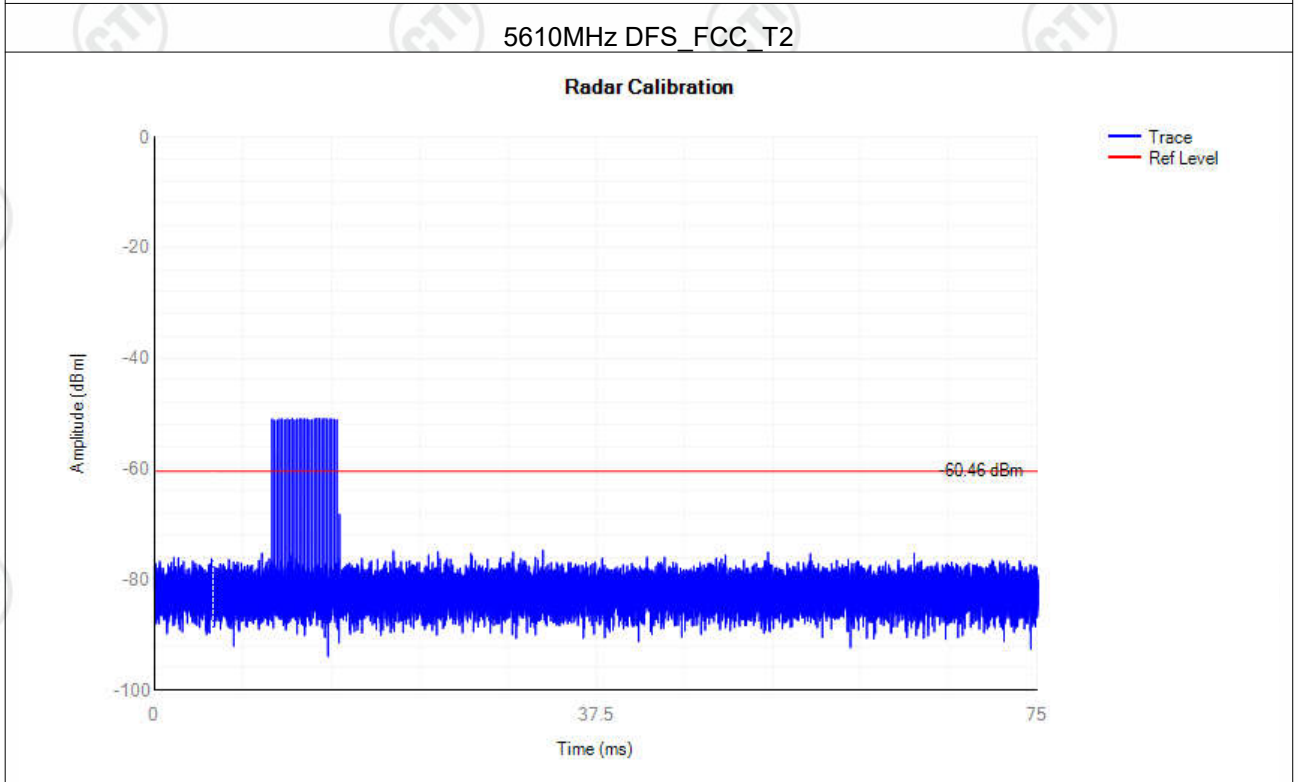
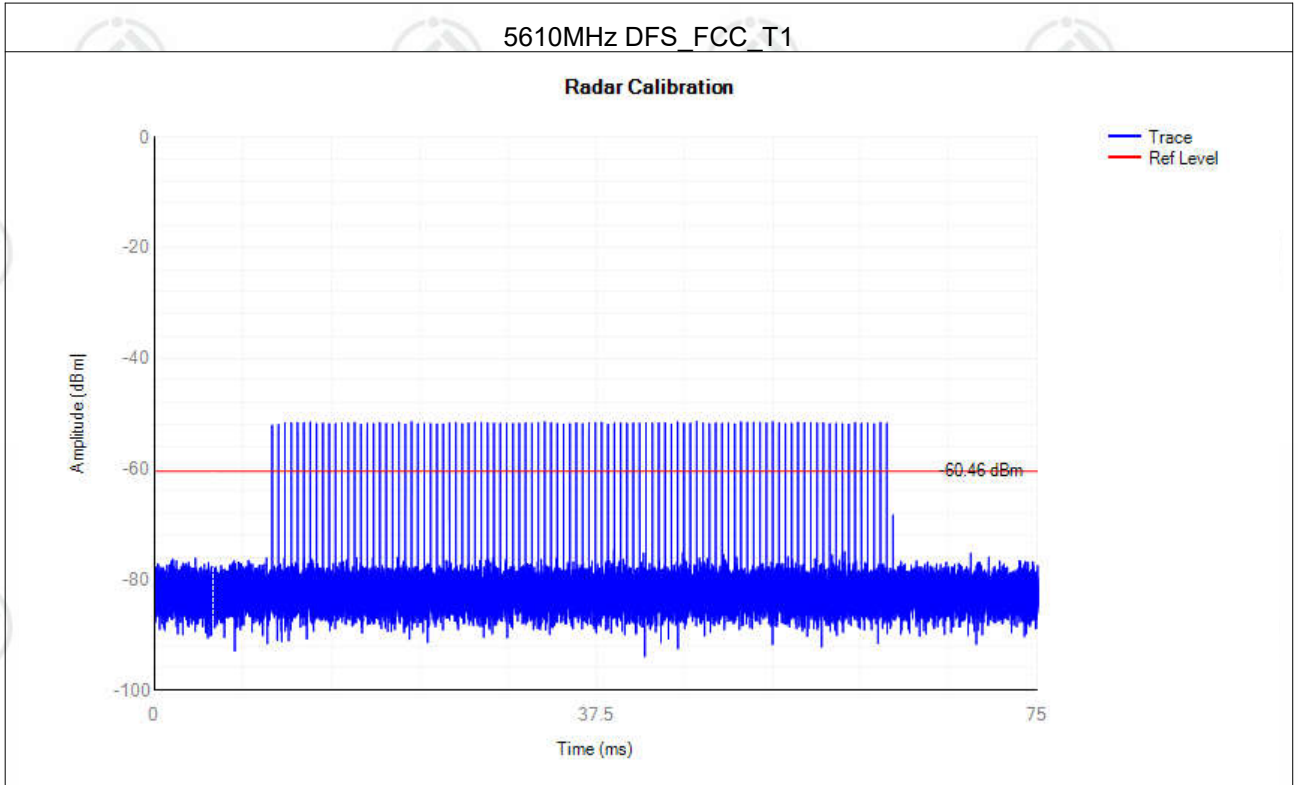

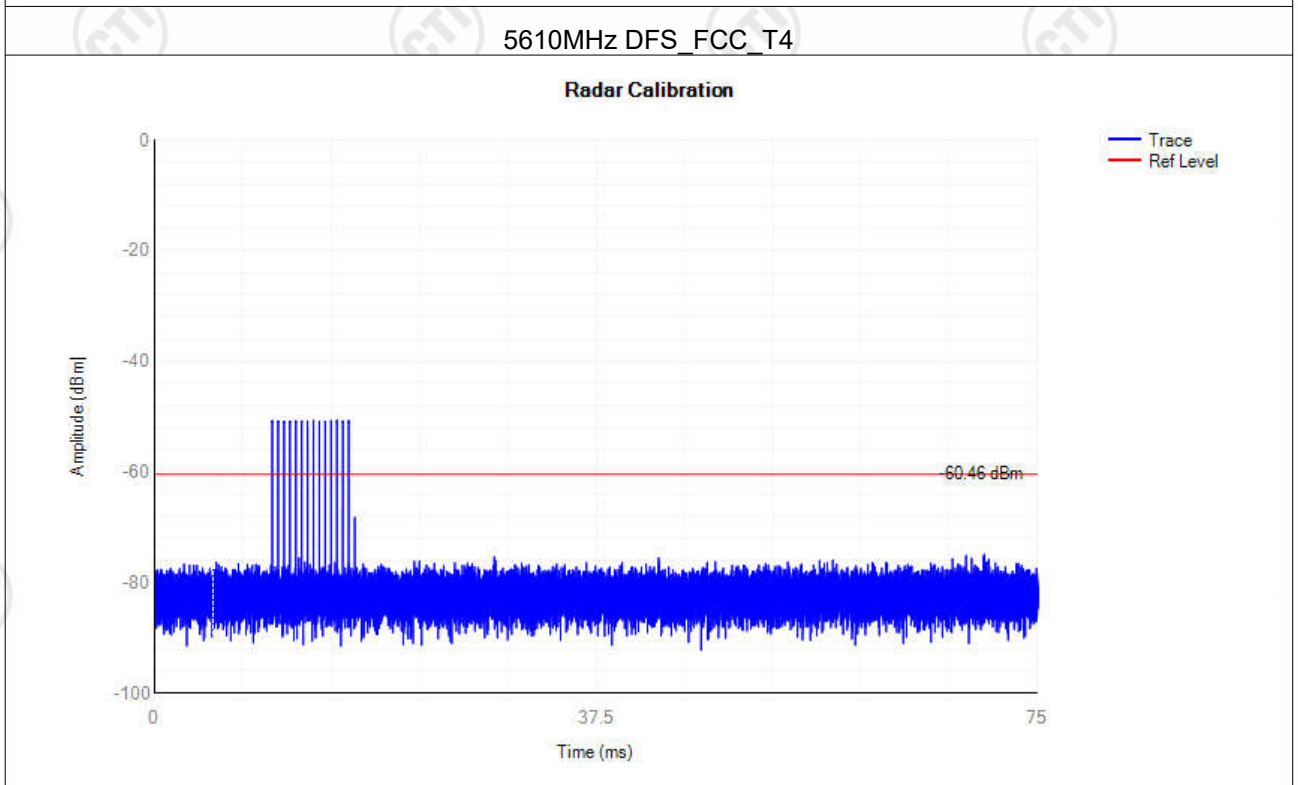
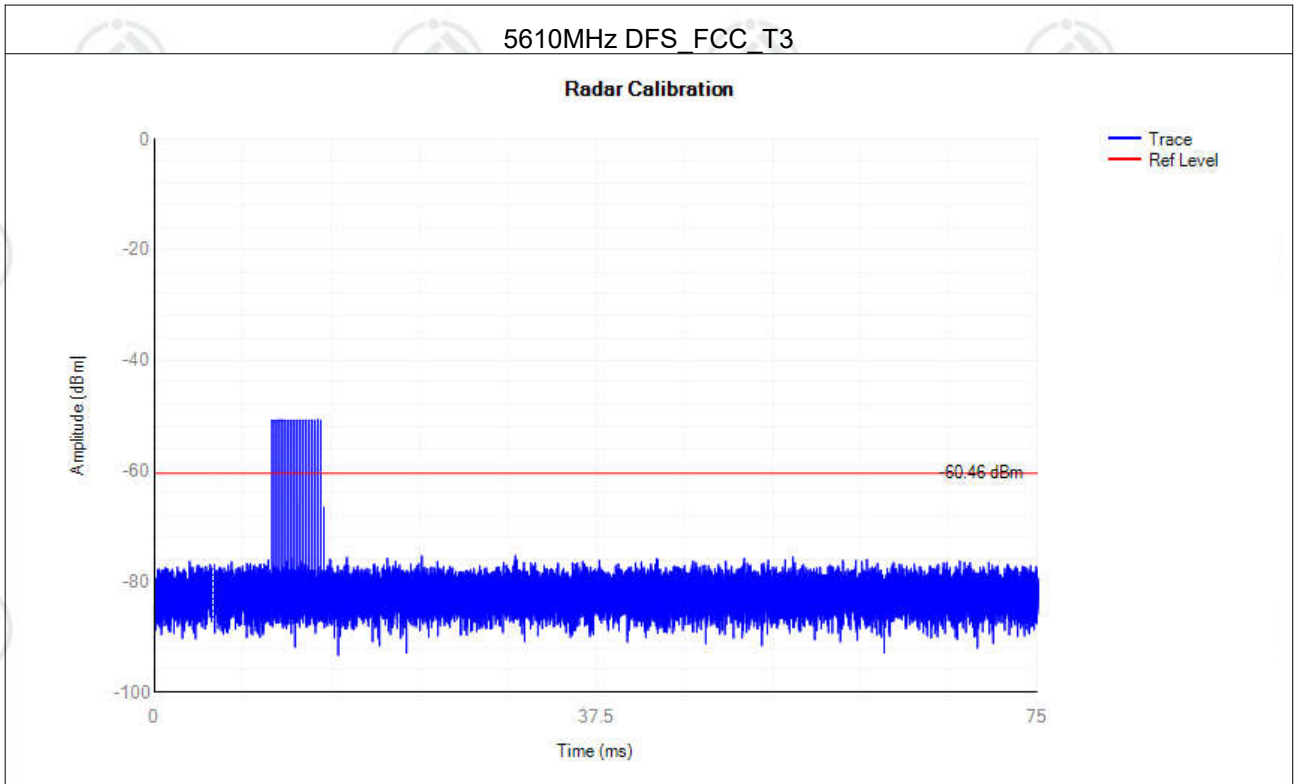



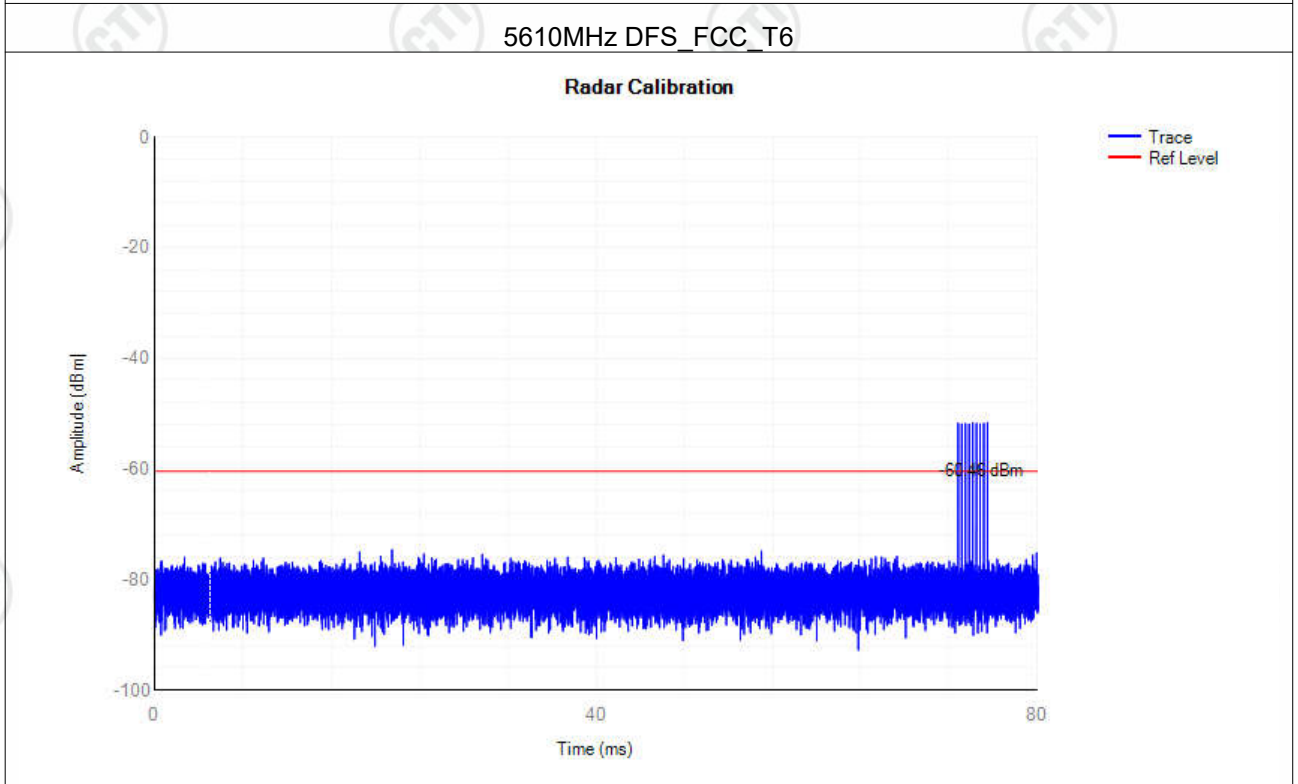
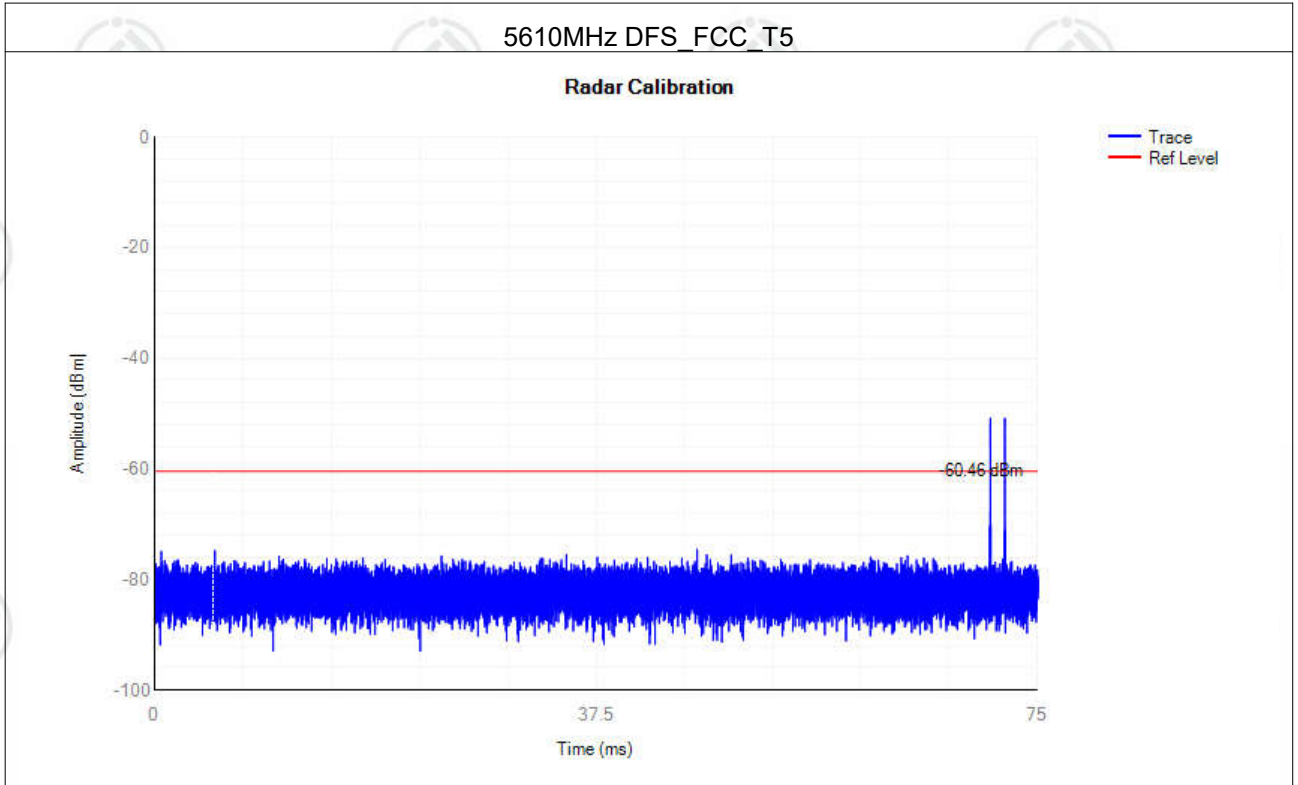

## 8.2 In-Service Monitoring for Channel Move Time, Channel Closing Transmission Time and Non-Occupancy Period

### Ambient condition

Temperature	Relative humidity	Pressure
23°C ~25°C	45%~50%	101.5kPa

### Methods of Measurement

These tests define how the following DFS parameters are verified during In-Service Monitoring;

- Channel Closing Transmission Time
- Channel Move Time
- Non-Occupancy Period

The steps below define the procedure to determine the above mentioned parameters when a radar Burst with a level equal to the DFS Detection Threshold + 1dB is generated on the Operating Channel of the U-NII device (In- Service Monitoring).

1. One frequency will be chosen from the Operating Channels of the EUT within the 5250-5350 MHz or 5470-5725 MHz bands. For 802.11 devices, the test frequency must contain control signals. This can be verified by disabling channel loading and monitoring the spectrum analyzer. If no control signals are detected, another frequency must be selected within the emission bandwidth where control signals are detected.
2. In case the EUT is a U-NII device operating as a Client Device (with or without DFS), a U-NII device operating as a Master Device will be used to allow the EUT (Client device) to Associate with the Master Device. In case the EUT is a Master Device, a U-NII device operating as a Client Device will be used and it is assumed that the Client will Associate with the EUT (Master). In both cases for conducted tests, the Radar Waveform generator will be connected to the Master Device. For radiated tests, the emissions of the Radar Waveform generator will be directed towards the Master Device. If the Master Device has antenna gain, the main beam of the antenna will be directed toward the radar emitter. Vertical polarization is used for testing.
3. Stream the channel loading test file from the Master Device to the Client Device on the test Channel for the entire period of the test.
4. At time T0 the Radar Waveform generator sends a Burst of pulses for one of the Radar Type 0 in Table 5 at levels defined in Table 3, on the Operating Channel. An additional 1 dB is added to the radar test signal to ensure it is at or above the DFS Detection Threshold, accounting for equipment variations/errors.
5. Observe the transmissions of the EUT at the end of the radar Burst on the Operating Channel for duration greater than 10 seconds. Measure and record the transmissions from the EUT during the observation time (Channel Move Time). Measure and record the Channel Move Time and Channel Closing Transmission Time if radar detection occurs. Figure 17 illustrates Channel Closing Transmission Time.

6. When operating as a Master Device, monitor the EUT for more than 30 minutes following instant T2 to verify that the EUT does not resume any transmissions on this Channel. Perform this test once and record the measurement result.

7. In case the EUT is a U-NII device operating as a Client Device with In-Service Monitoring, perform steps 1 to 6.

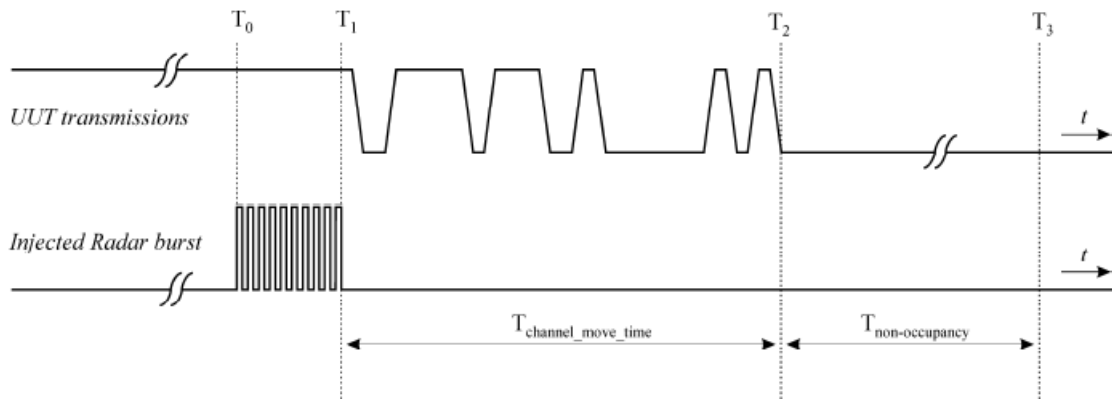

Example of Channel Closing Transmission Time & Channel Closing Time

### Limit

Channel Move Time	≤10s
Channel Closing Transmission Time	≤200ms + 60ms (over remaining 10s period)
Non-Occupancy Period	≥30min

Note 1: Channel Move Time and the Channel Closing Transmission Time should be performed with Radar Type 0. The measurement timing begins at the end of the Radar Type 0 burst.

Note 2: The Channel Closing Transmission Time is comprised of 200 milliseconds starting at the beginning of the Channel Move Time plus any additional intermittent control signals required to facilitate a Channel move (an aggregate of 60 milliseconds) during the remainder of the 10 second period. The aggregate duration of control signals will not count quiet periods in between transmissions.

**Test Result:**  
**Shutdown Time**

Mode	Frequency (MHz)	Channel Move Time (s)	Limit Channel Move Time (s)	Close Transmission Time (s)	Limit Close Transmission Time (s)	Close Transmission Time after 200ms(s)	Limit Close Transmission Time after 200ms (s)	Verdict
ac20	5260	0	10	0	0.26	0	0.06	Pass
ac20	5500	0	10	0	0.26	0	0.06	Pass
ac40	5270	0	10	0	0.26	0	0.06	Pass
ac40	5510	0	10	0	0.26	0	0.06	Pass
ac80	5290	0	10	0	0.26	0	0.06	Pass
ac80	5530	0	10	0	0.26	0	0.06	Pass
ac80	5610	0.5293	10	0.0036	0.26	0.002	0.06	Pass

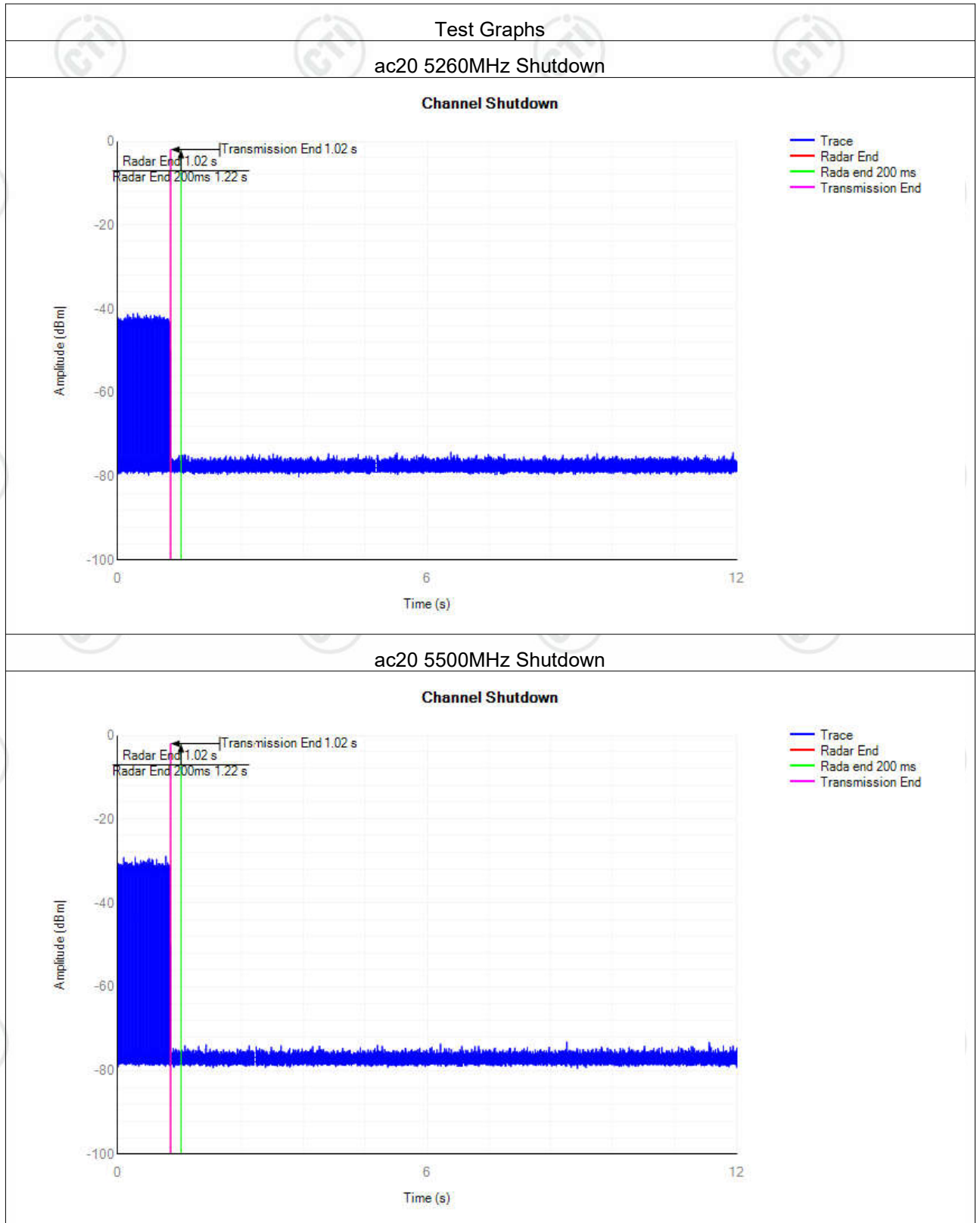

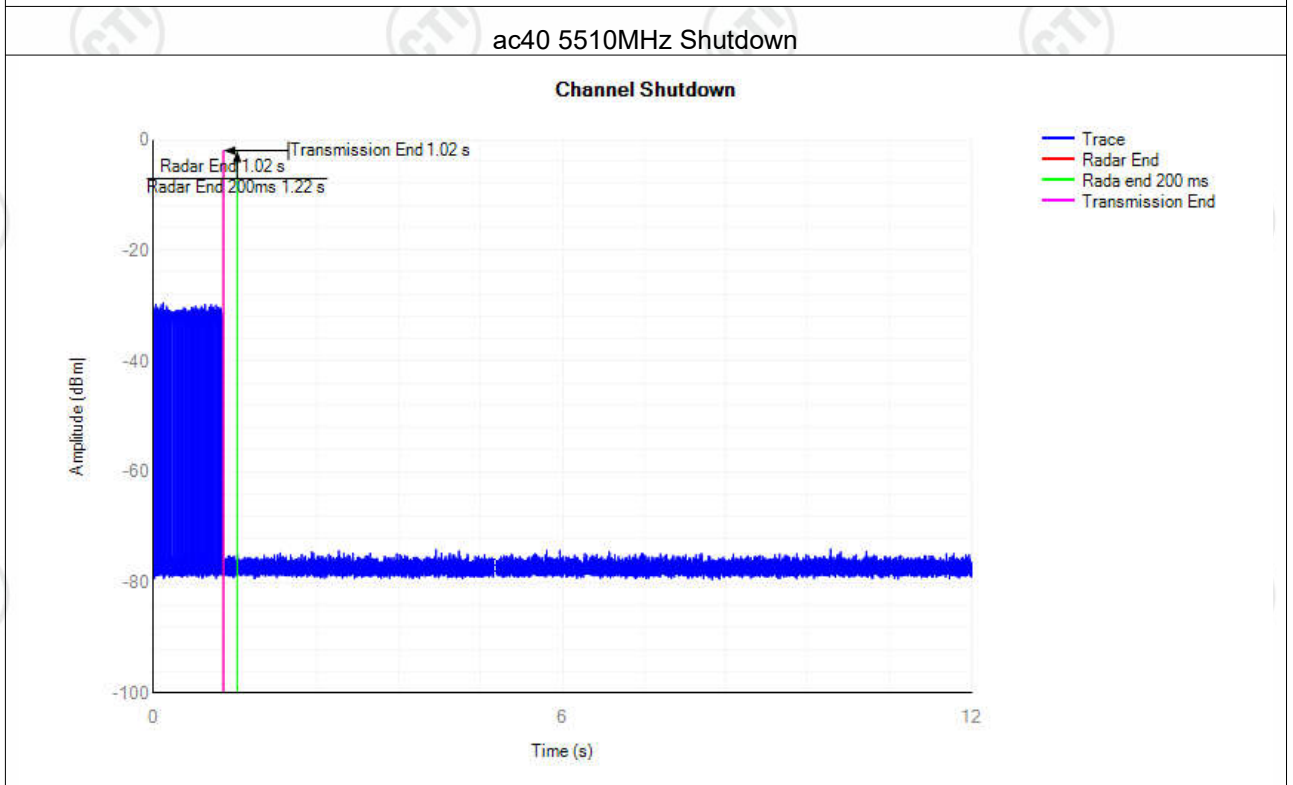
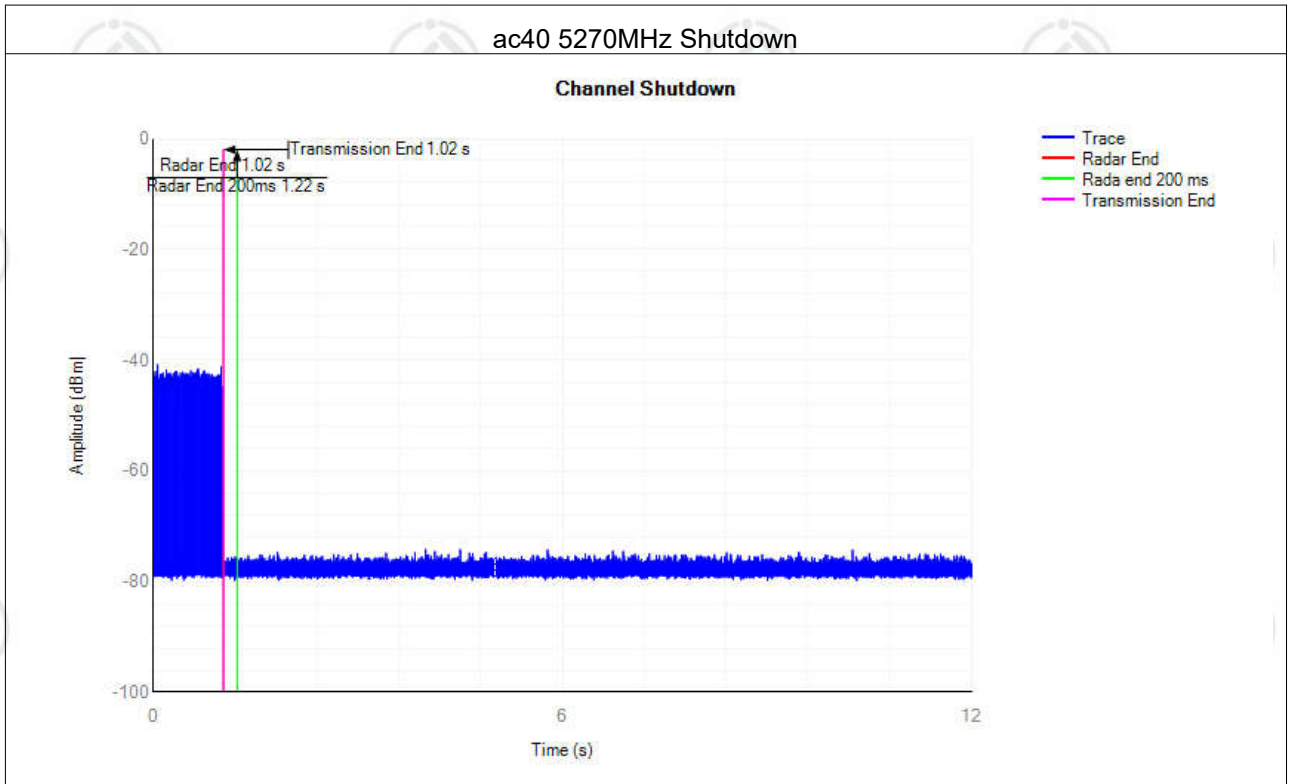

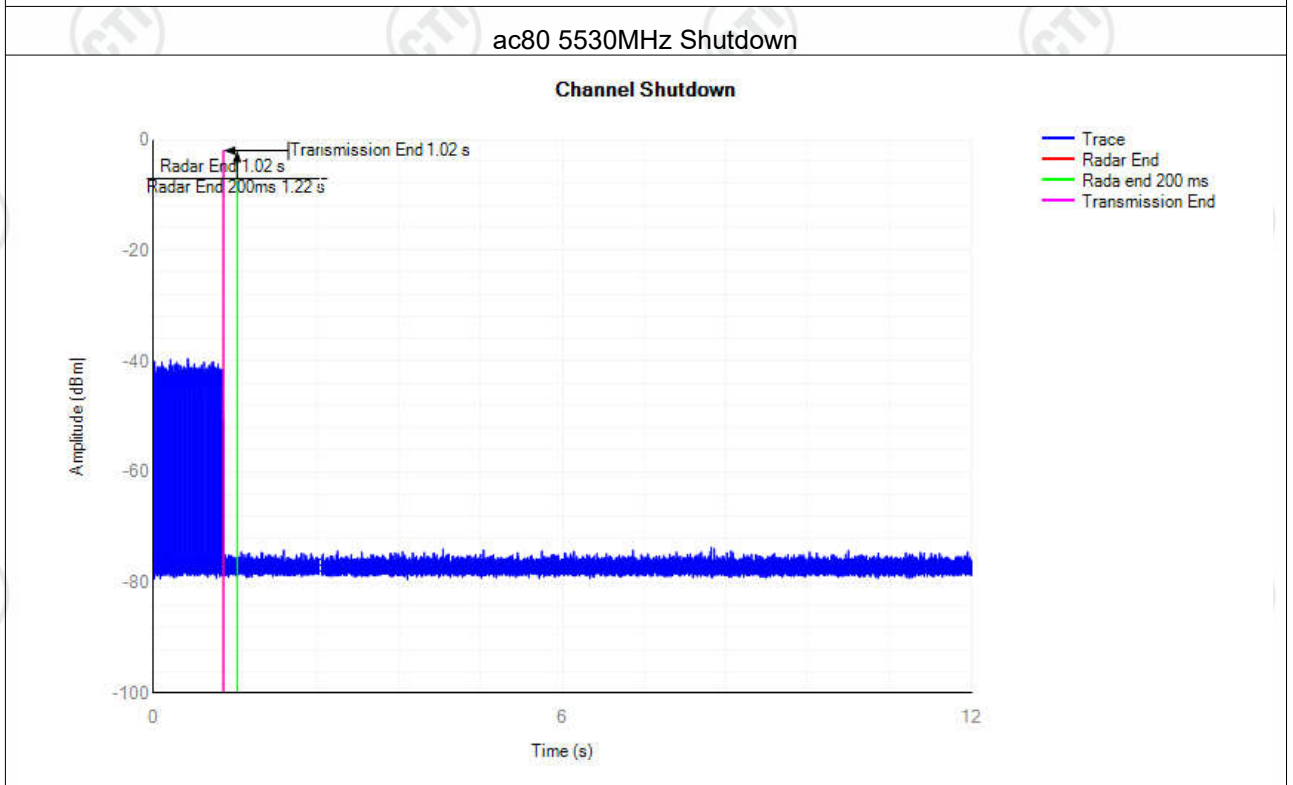
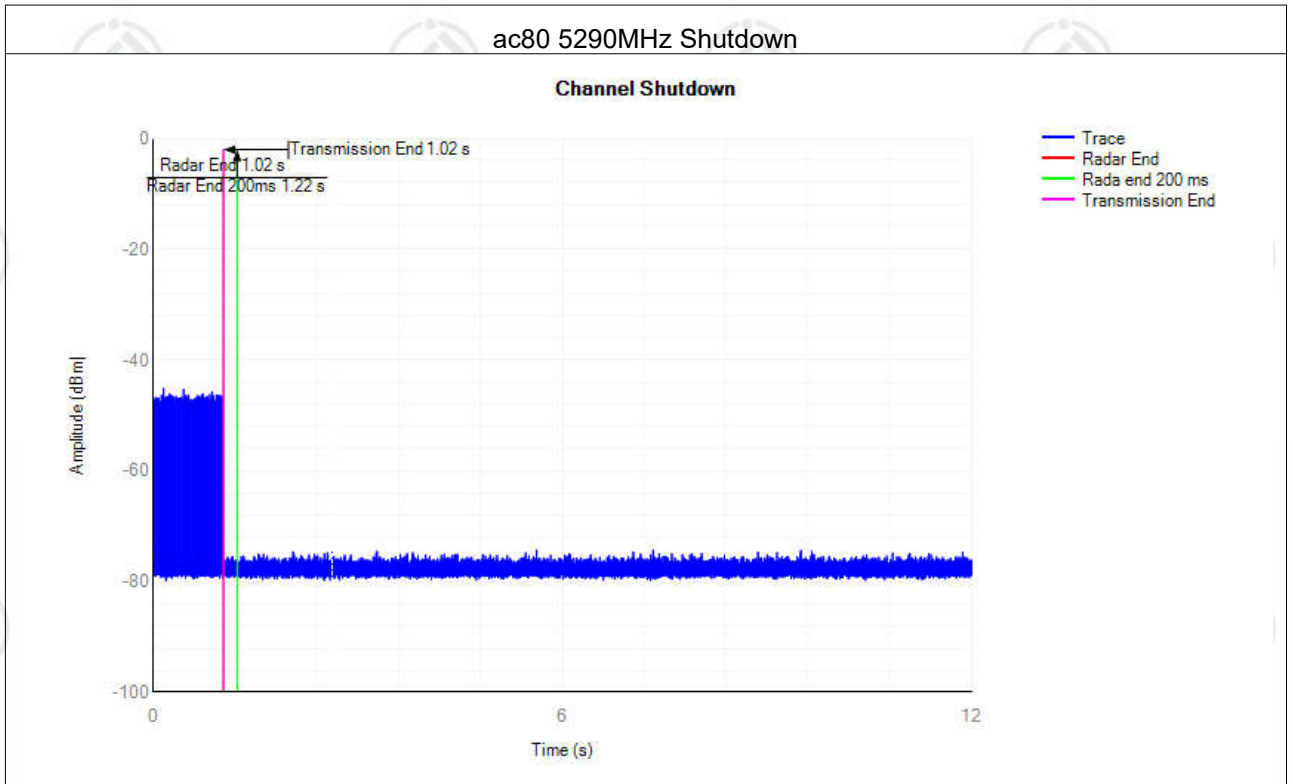

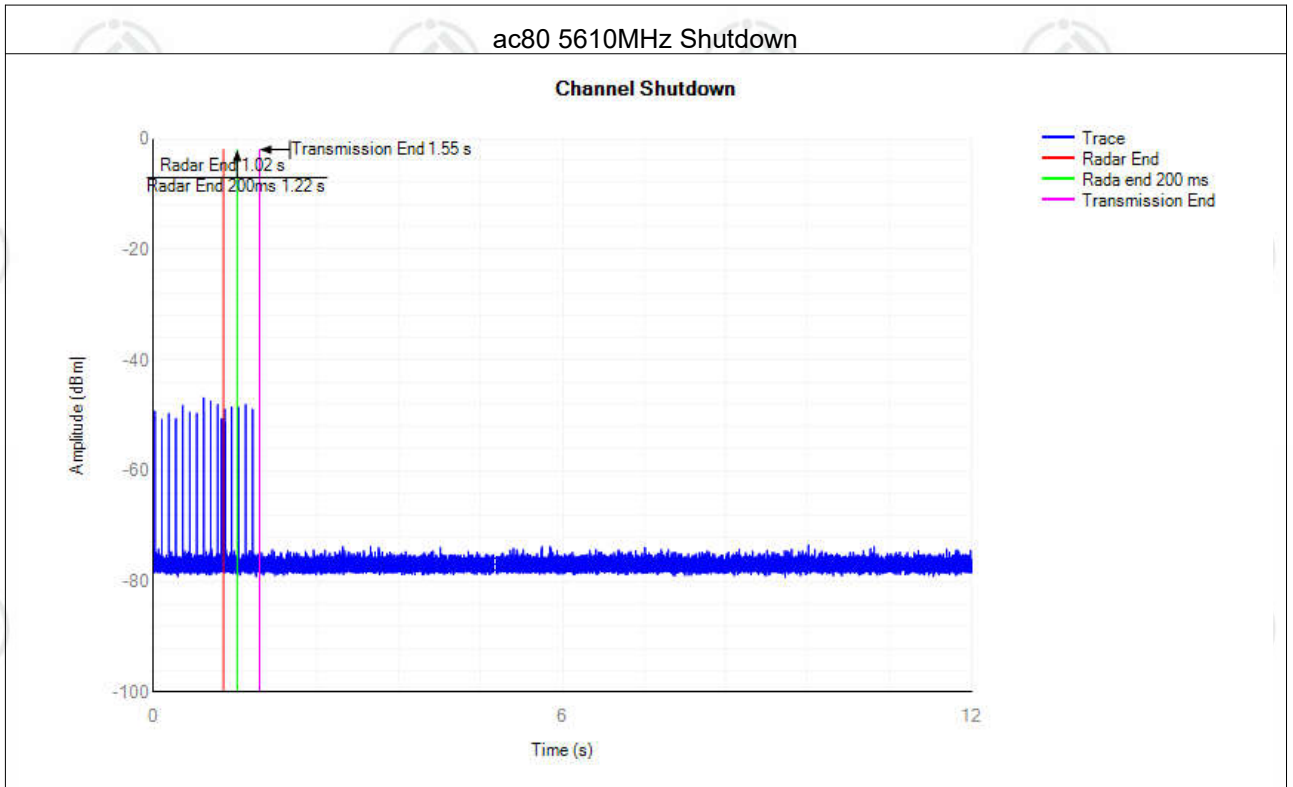



## Non-Occupancy Period

Mode	Frequency (MHz)	Result	Verdict
ac20	5260	See test Graph	Pass
ac20	5500	See test Graph	Pass
ac40	5270	See test Graph	Pass
ac40	5510	See test Graph	Pass
ac80	5290	See test Graph	Pass
ac80	5530	See test Graph	Pass
ac80	5610	See test Graph	Pass

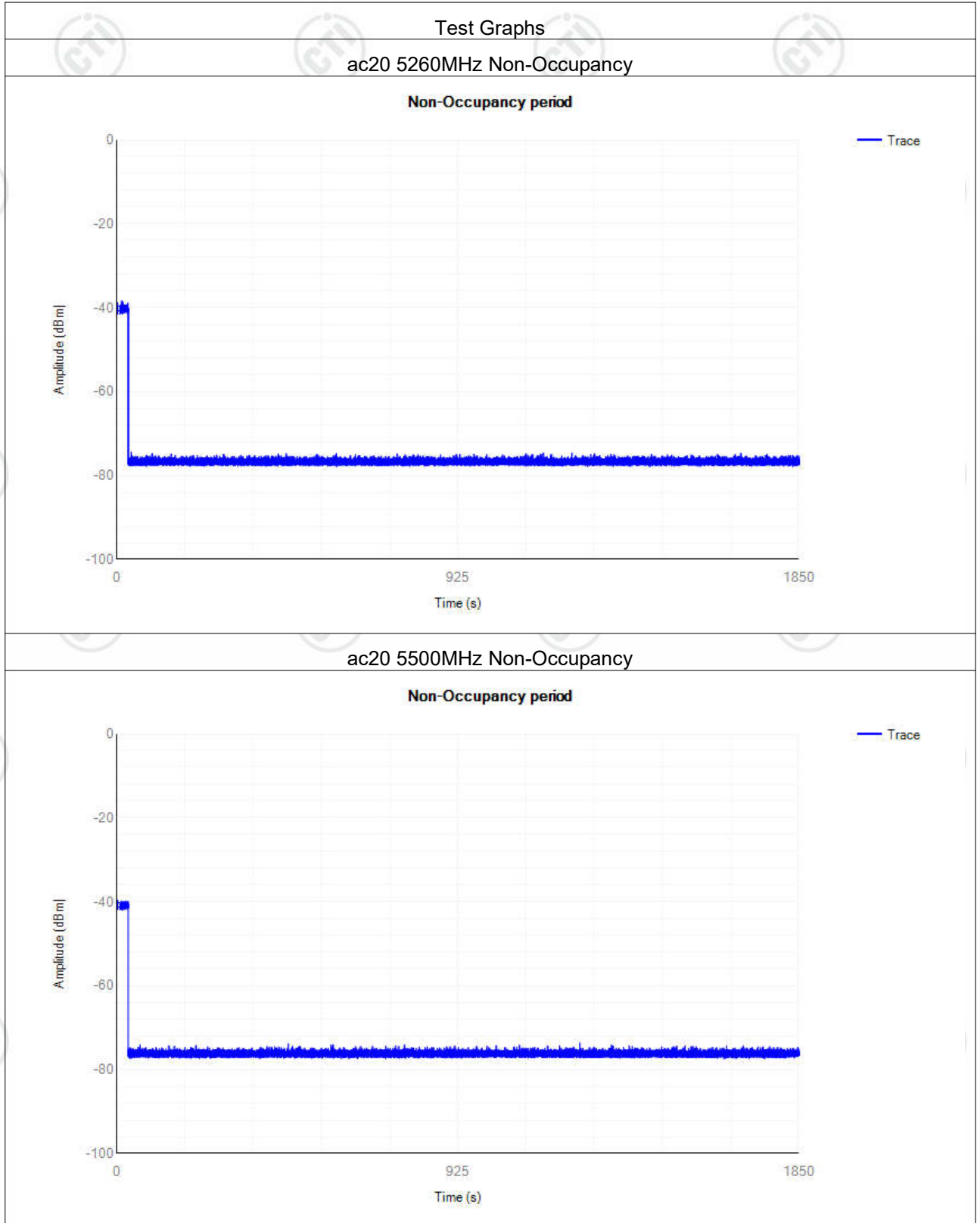

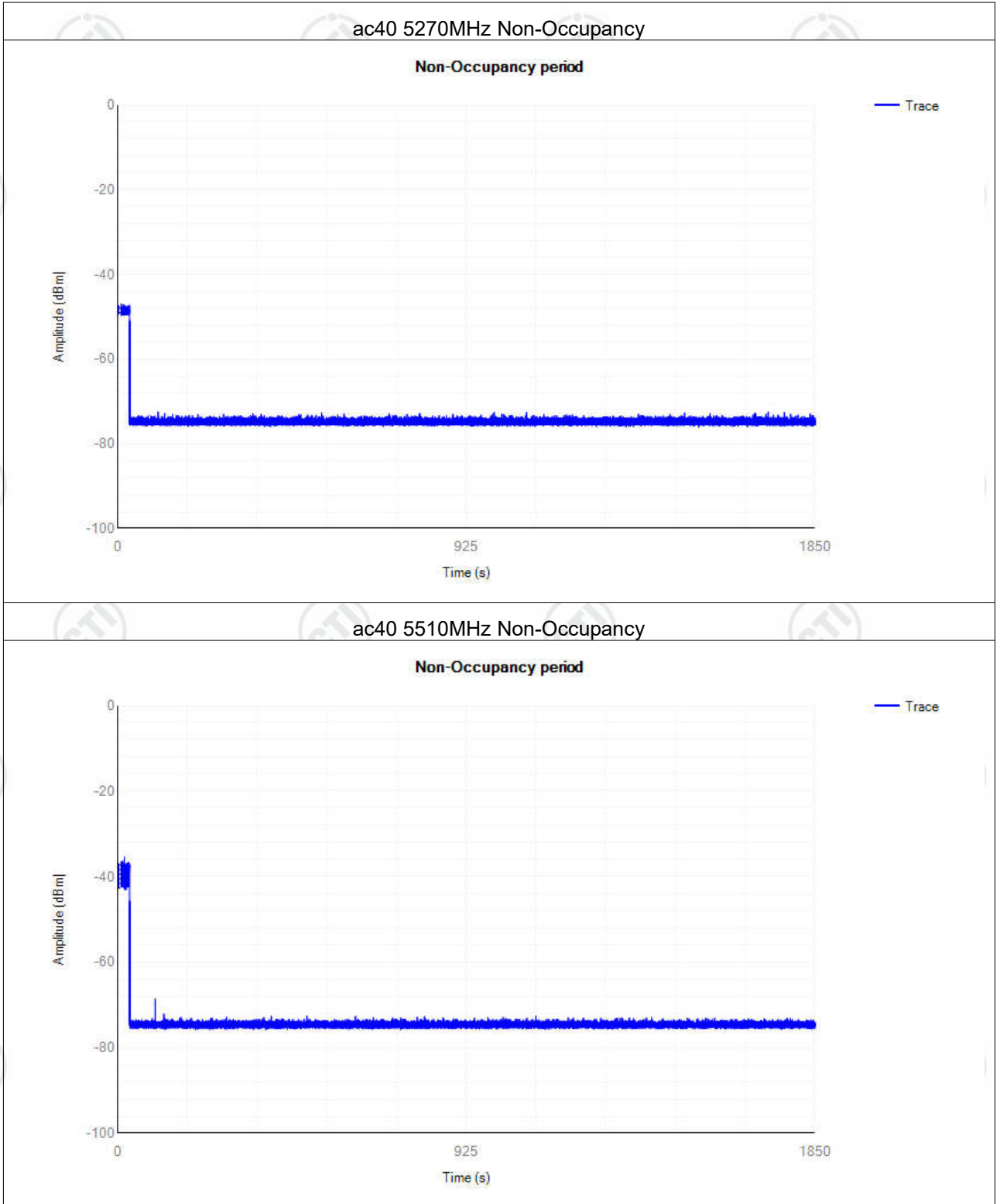

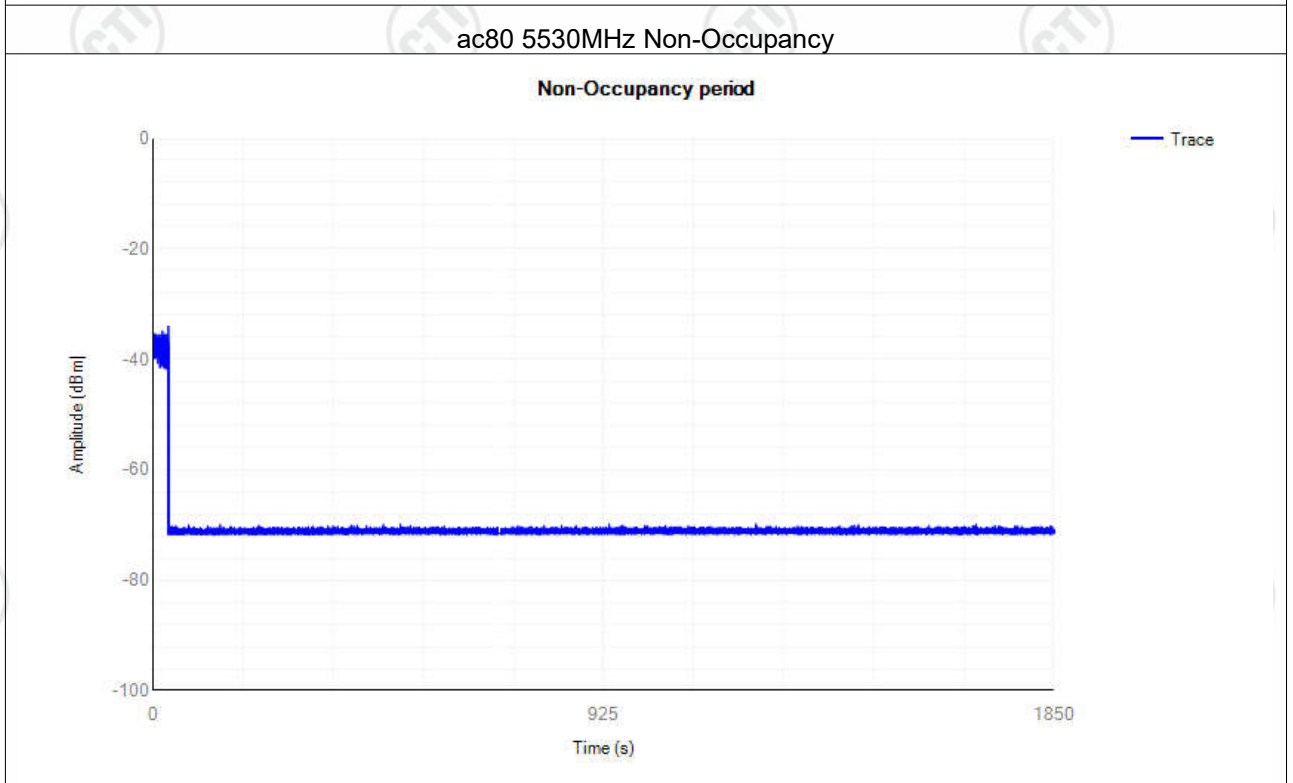
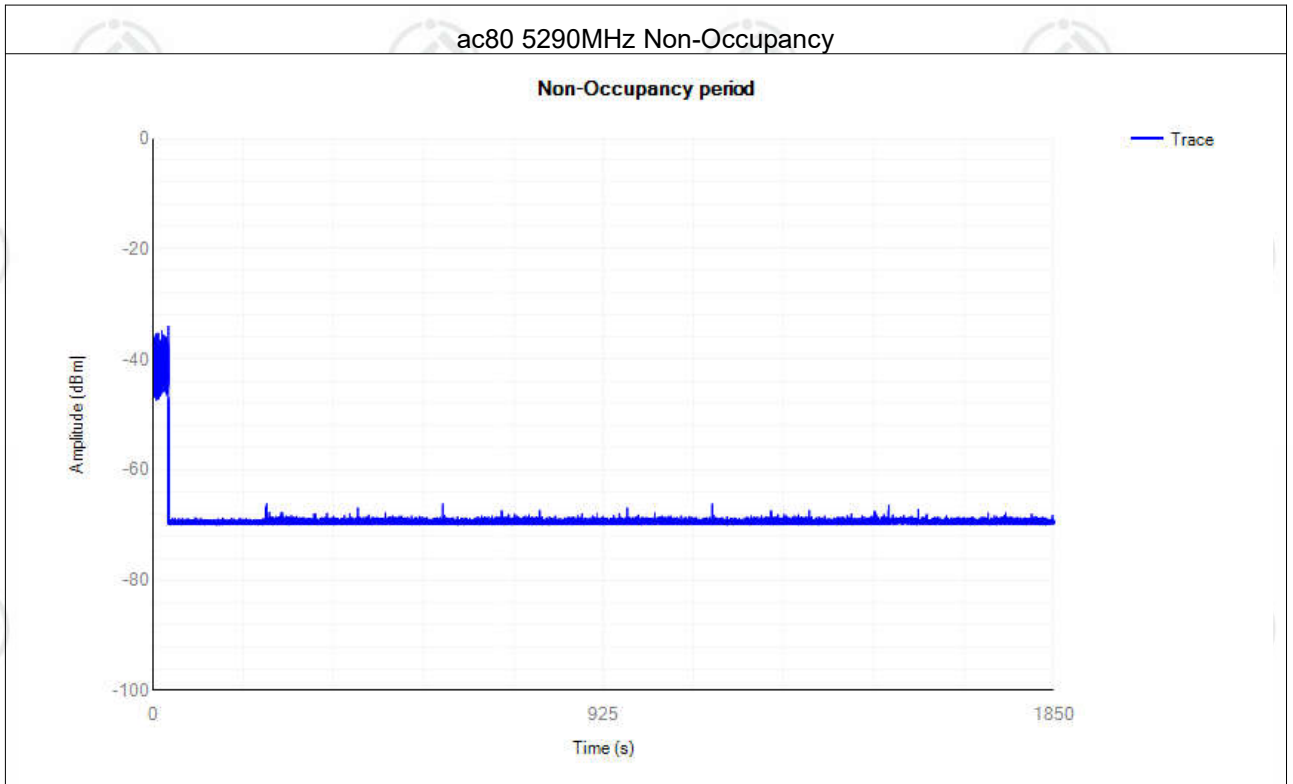

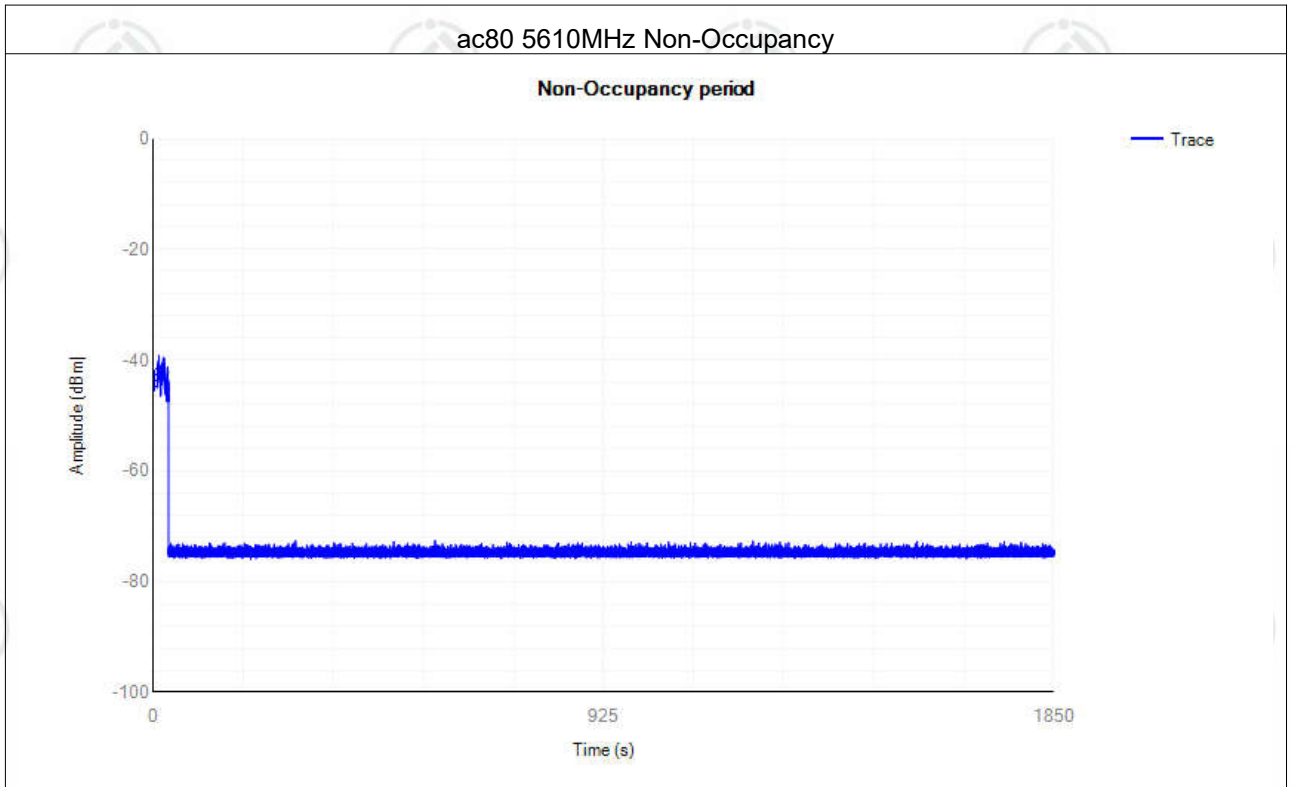

## **PHOTOGRAPHS OF EUT Constructional Details**

Refer to Report No.EED32Q80705101 for EUT external and internal photos.

The test report is effective only with both signature and specialized stamp, The result(s) shown in this report refer only to the sample(s) tested. Without written approval of CTI, this report can't be reproduced except in full.

\*\*\* End of Report \*\*\*