

ACCESSORIES & PORT SPECIFICATIONS



Handle Grips
Pause & Resume Class



Rope Grip



Straight Bar
Pause | Resume | Adjust Resistance



Ankle Strap

Power
Cable

Reset
Switch

Off/On



USB
OTG

USB

Network
Cable



ASSEMBLY

Assembly Setup

- Remove Main Frame from packaging and stand upright in assembly location.
- Remove wooden support panels from both sides of Main Frame, being sure to keep Main Frame stabilized. **IMPORTANT NOTE:** Main Frame will **NOT** stand without support before stabilizer legs are assembled.

We recommend 2–3 people minimum for assembly.

STEP
1

Assembly should take place on a soft surface, such as carpet or a rug, or with the cardboard box opened to protect the floor.

STEP
2

Assembling the Legs

- Affix left Stabilizer Leg (D01) and right Stabilizer Leg (D02) to Main Frame (A01) with bolt M10×15 (L01). Do not fully tighten bolts.
- Fasten legs to Main Frame (A01) with 4x bolt M10×95 (L02) per side. Tighten all screws from above steps.
- Affix Concrete Mounting Bracket (H04) at inner side of Stabilizer Legs with 3x bolt M10×25 (L01), 3x spring washer (L05) and 3x flat washer (A09) per side and tighten.

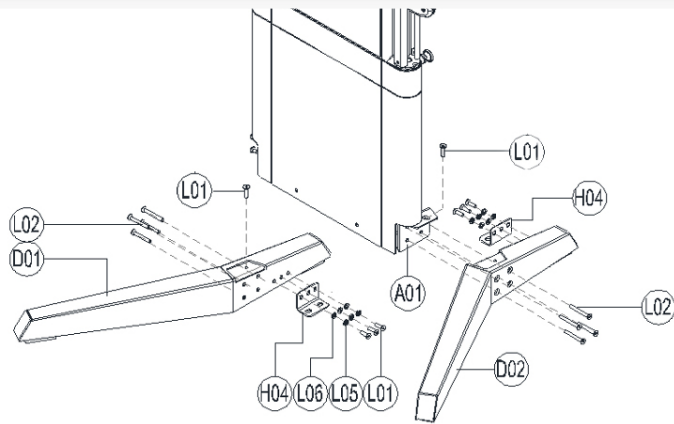
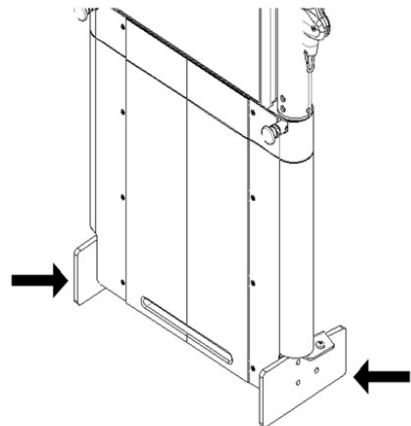

STEP 3

Assembling the Accessory Rack

- a. Attach Accessory Rack Cover (F21) into C-shaped holder (A13) with 2x bolt M5×20 (L04) and tighten.

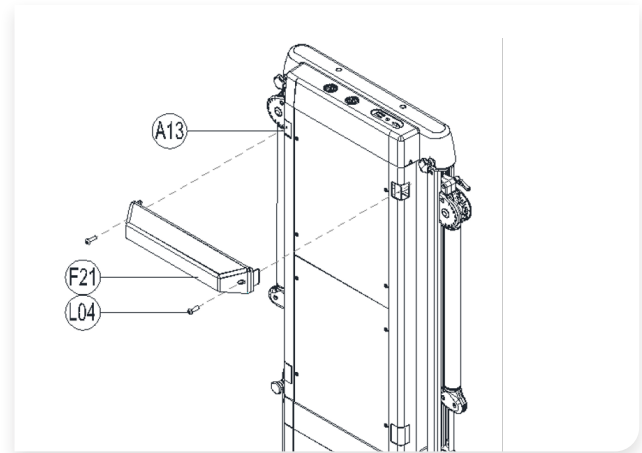

Detailed step for concrete sleeve anchor to ground

- a. Follow the metal plate to ground position (H04) to mark the installation position for concrete sleeve anchor (L06) ;
- b. Use a 15/32 or 31/64 concrete drill bit to drill a depth of 55mm or more (2.17 inches) at the marked position and clean the debris in the hole.
- c. Before putting the concrete sleeve anchor (L06) into the drilled hole, rotate its nut to the end of the thread; Use a hammer to tap the top of the anchor (L06) to secure it firmly.
- d. Tighten the nut with a force of about 30N · m, then loosen it to move the machine to the screw position for installation and fixation.

Note:

During step a: don't apply too much force onto the anchor, so to breaking.

For step b, under correct installation of concrete sleeve anchor (L06) in concrete grade 150 #, it can withstand a minimum tensile force of 940kg, the tensile limits vary for different concrete type.

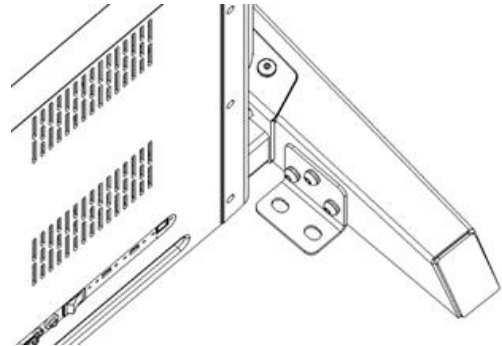

BATTERY INSTALLATION

Handle Grip Battery Installation

- Loosen and remove screws (A) from Handle Grip end cap without button using the included L-Shaped Wrench (L03).
- Remove End Cap (B) and Handle Tube (C).
- Insert Button Battery (D) into battery compartment with positive (+) pole facing upwards.
- Fix Handle Tube (C) and End Cap (B) back into place and replace screws (A).

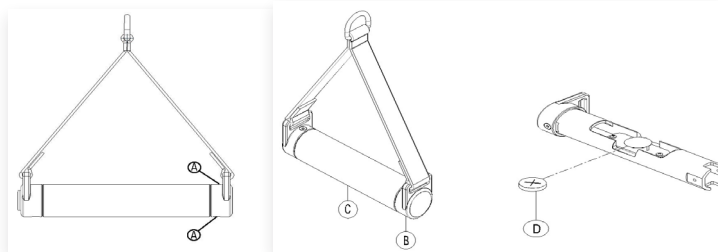

Smart Bar Module Battery Installation

- Remove Button Panel (F) from Silicone Base (E).
- Insert Button Battery (D) into battery compartment with positive (+) pole facing upwards.
- Press Button Panel (F) back into place on Silicone Base (E).

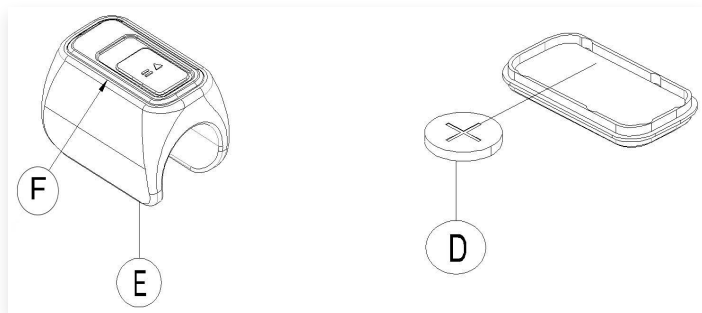

How to use smart accessories

Smart module on bar

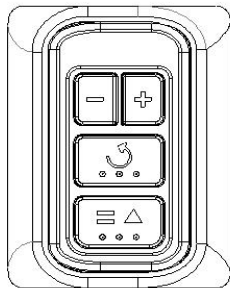

+: Click once to add weight by 1, long press to increase weight continuously

-: Click once to reduce weight by 1, long press to reduce weight continuously;

↻: click to clear the reps;

■/▲: click to start, click again for pause;

Sync: when enter Sync accessories in setting page, press any key to pair the smart accessory with strength machine

Smart handle

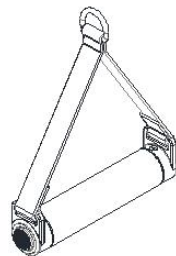

Press the keypress to start/pause

Sync: when enter Sync accessories in setting page, press any key to pair the smart accessory with strength machine

Lateral rotation adjustment (9 levels).

- Lift arm a little bit for easy operation, slide and hold the slider (C26) following the arrow direction to unlock.
- Rotate arm vertically till proper position.
- Then release the slider (C26) to lock the position.
- There are 9 levels to choose from.

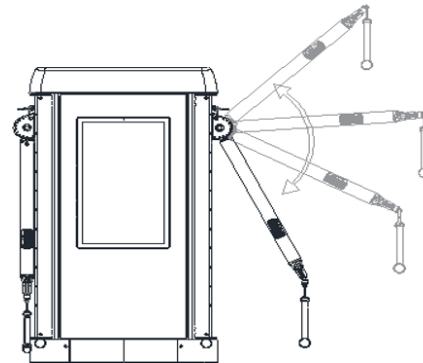

ARM ADJUSTMENTS (cont'd.)

Sliding up and down adjustment (11 levels).

- Pull up the 7-shaped lever (C51) to unlock, slide the arm up and down to the required height.
- release the 7-shaped lever (C51) to lock the position.
- There are 11 heights to choose from.

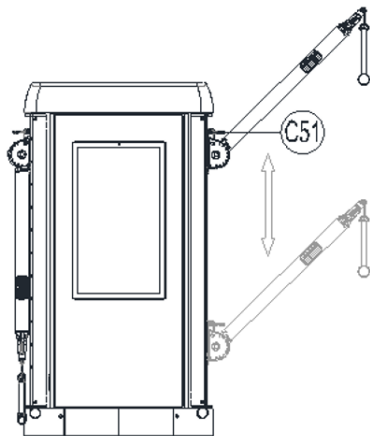
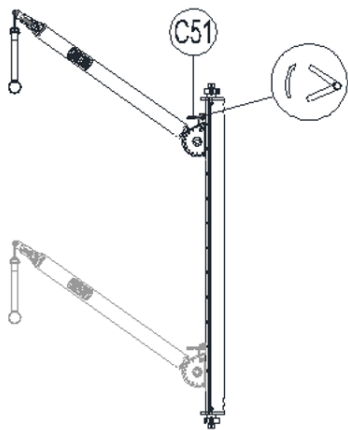

STEP
2



Horizontal rotation adjustment (3 levels).

- a. Pull and hold the pull pin head (C14), rotate the arm horizontally to the required position.
- b. Release the pull-pin head into place to lock the position.

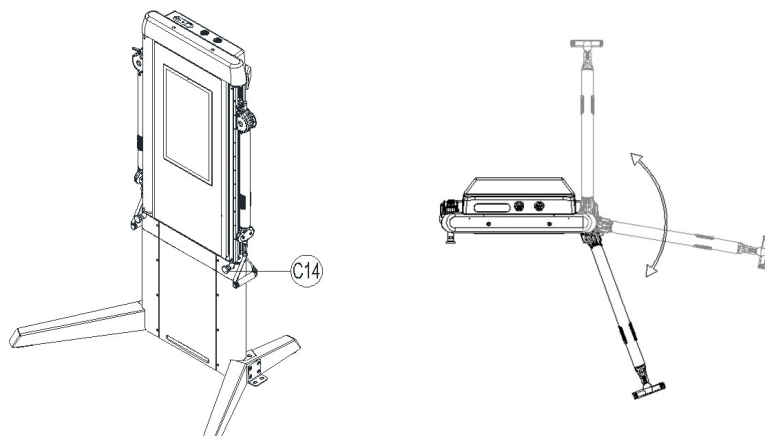

STEP
3



STRENGTH MACHINE USED WITH BENCH

The bench (not provided) is placed in front of the strength machine, adjust the arm to the proper position for variety exercises, e.g., squat presses, seated pull-ups.

Bench Not Provided

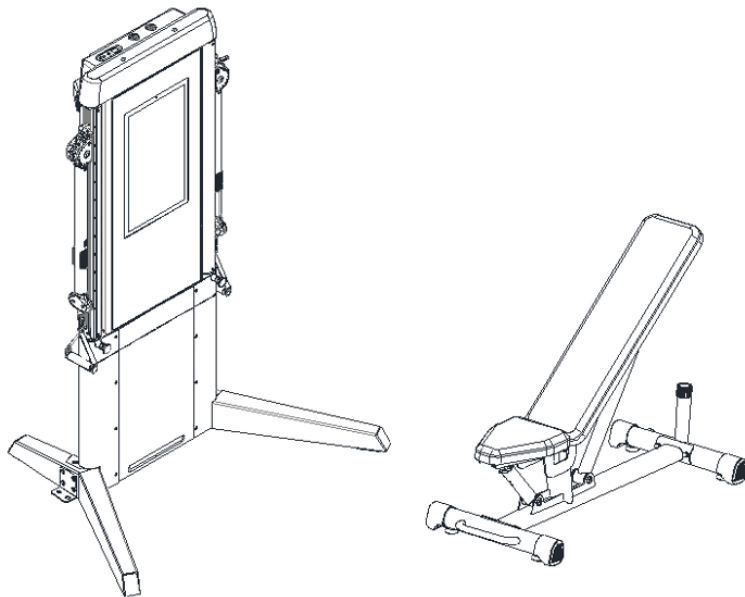

WORKOUTS



Shoulder Press



Cable Squat



Chest Fly



Cable Kickback



Bicep Curl



Row



Abdominal Crunch



Incline Bench Press



Rope Pull-Down



Cable Twist



USING THE ECHELON STRENGTH PRO

Activate Echelon Premier Membership to connect to classes.

You should have received an activation email after purchasing this product.

- a. Follow the link from the activation email.
- b. Choose "**Sign Up Now**" and follow the prompts to complete your membership enrollment.



TERMINOLOGY

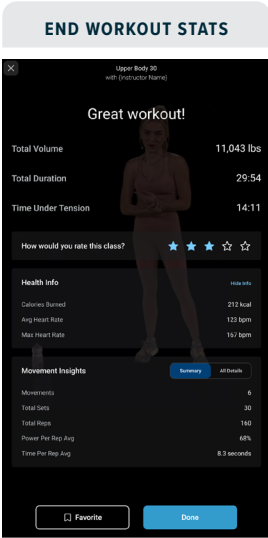
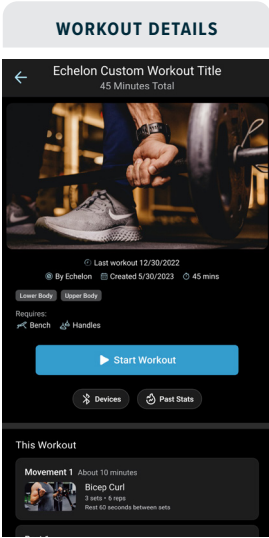
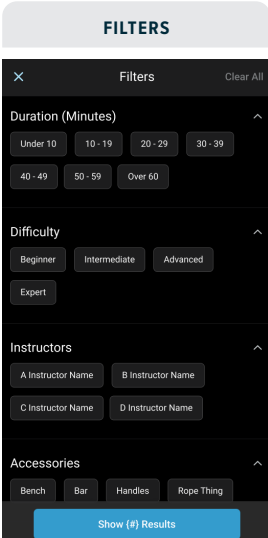
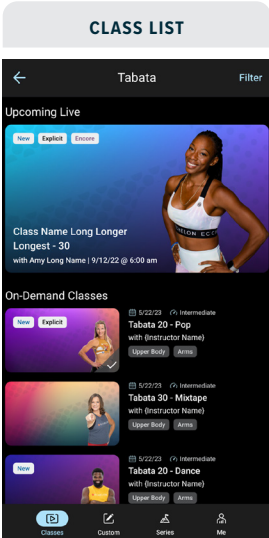
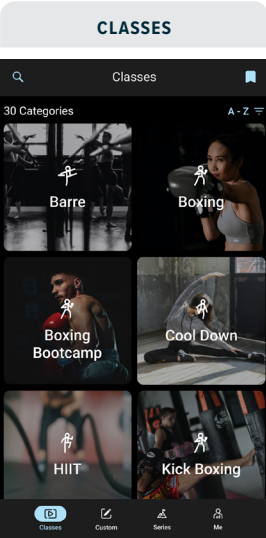

APP INSTRUCTIONS (cont'd.)

THE BASICS

Introducing the Echelon Strength Pro

The all-new cutting edge digital strength machine. Upgrade your personalized digital training with 100's of movements, numerous pre-built workouts, and the ability to create and save custom workouts.

SETUP

Activate Echelon Premier Membership to connect to classes.

You should have received an activation email after purchasing this product.

- a. Follow the link from the activation email.
- b. Choose **"Sign Up Now"** and follow the prompts to complete your membership enrollment.

Connecting to the Echelon Fit® App

Ensure your Echelon Strength Pro is powered on.

- a. Follow the link from the activation email.
- b. Choose **"Sign Up Now"** and follow the prompts to complete your membership enrollment.

Log in to the Echelon Fit® App.

- a. Use the email and password used to create your membership account. If you haven't made an account, visit member.echelonfit.com and follow the prompts and begin account creation.
- b. Select user. There may only be one option.

Select a class.

- a. We recommend a welcome class, but any class will work.
- b. Press play.



GENERAL FUNCTIONALITY

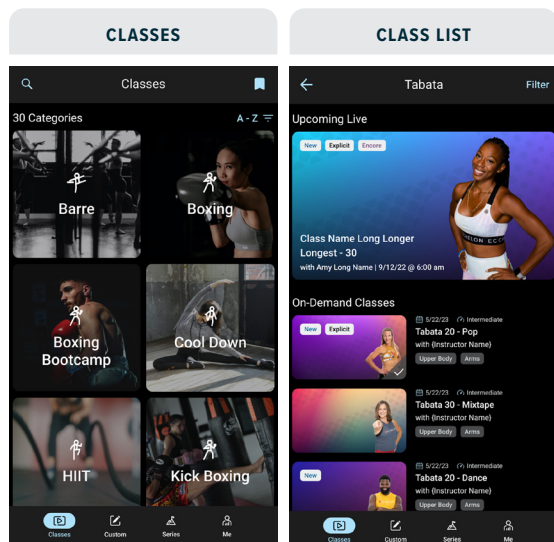

Introducing the Echelon Strength Pro

The Classes Page can be found on the far left side of the navigation bar at the bottom of the screen.

This page will show the available categories for classes.

You can scroll through the available class categories. Select one to display all available classes for that category.

Sort

Sorts classes A–Z, Z–A, or by Most Popular.

How do I see classes?

Classes are found by going to the Classes page and selecting a category. Once a category is selected, the class list will be displayed.

At the top of the class list, it will show any upcoming Live classes for that category. It will only show a current live class or the next upcoming live class. **If there isn't one scheduled, the live section will not appear.**



APP INSTRUCTIONS (cont'd.)

GENERAL FUNCTIONALITY (cont'd.)

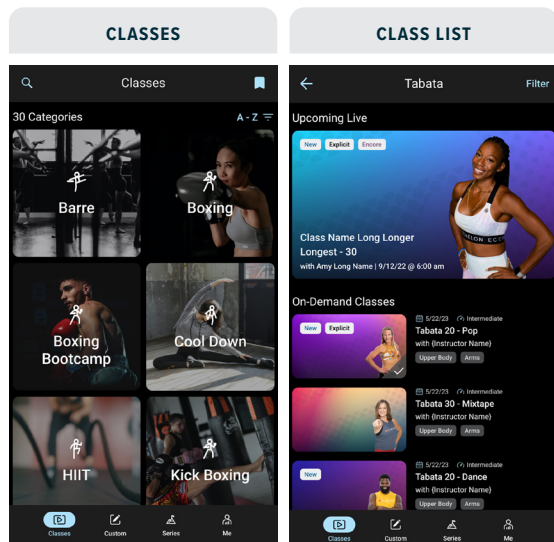

FROM PREVIOUS PAGE

How does the search work?

The Search can be found by going to the Classes page and selecting the magnifying glass in the top left corner. On the search page you will see popular searches and recent searches. You can search for class names, keywords, instructors or class types.

Favorites Page

Tapping the bookmark icon at the top of the Classes screen will take you to your Favorites page. This page contains a collection of all the classes you have favorited.

The Favorites screen will include Filter capabilities to quickly sort through and find classes.

Custom Page

Movement Filters for creating a custom workout.



WORKOUTS

General

What is a 'circuit' for my workout?

A circuit will cycle through each movement. You will do one set of the first movement, one set of the next, one set of the following, then start from the beginning until all sets have been completed.

Echelon

What is an Echelon Workout?

An Echelon Workout is one created by the Echelon team. These do NOT have a video.

Where are Echelon Workouts found?

Echelon workouts are found on the 'Custom' page. Once on the Custom page, the workouts will be split into 2 sections:

'My Workouts' and 'By Echelon'.

Select the 'By Echelon' header to see all available Echelon Workouts.

How do I know if it's an Echelon Workout?

Echelon Workouts will be indicated by the 'By Echelon' tag on the workout details page.

Custom

What is a custom workout?

A custom workout is made by you, the user. It can be whatever duration, type and intensity you choose.

How do I make a custom workout?

Start by going to the 'Custom' page, found on the bottom navigation bar.

1. Start by going to the 'Custom' page, found on the bottom navigation bar.
2. Select 'Create Workout' in the bottom right.
3. You will be prompted to enter a name for the new workout.
4. Once named, you will be brought to your new custom workout! From here you will add movements.
5. Select '+ Movement' from the bottom.
6. On the 'Movement' page, you will be able to select, scroll, filter, or search for a movement.
7. Select your first movement and you will be on the



APP INSTRUCTIONS (cont'd.)

WORKOUTS (cont'd.)

'Edit Movement' page. From here you can edit:

- a. Sets — the collections of Reps
- b. Reps — the amount of movements
- c. Use Interval sets will allow you to use time in lieu of reps for each set. **If toggle is applied, the 'reps' change to 'time'.**
- d. Rest between sets — allows you to modify your rest between sets
- e. Estimated Movement Time — this is the time you, the user, things this movement will take. This applies to the whole movement, not each set. This is used to calculate the estimated time of the workout.
- f. Add Rest after Movement - this allows you to enable and set the rest time between this movement and the next one.
- g. Once one, select '+ Add to Workout'. You will be taken back to the workout screen with all movements. From here you can continue adding movements. You will see rest times between movements and you can use the arrows to edit the order of the movements.
- h. After you are done adding and editing movements, select 'Done'.
- i. Your custom workout is now ready!

Freestyle

What is freestyle?

Freestyle allows a user to pick up and go on the strength machine. There is no pre-determined workout structure, allowing the user to do what they wish.

Disengaging the weight and pausing the workout will progress the user to the next set and reset their rep counter. Users can choose their workout style by tapping the button above the reps and set statistics.

They may choose: 'Show Single Rep Counter' or 'Show Left and Right Rep Counters'.

Note: In **Commercial mode**, Freestyle is found in the standard navigation on the bottom of the screen. In **Residential mode**, you can find Freestyle via an option on the 'Custom' Tab, similar to where you would find Echelon Created Workouts.



RESISTANCE MODES

What is a resistance mode?

Resistance modes can vary based on workout type, movements, and preference. The modes are:

Standard — constant resistance applied for both eccentric and concentric movements.

Concentric — the resistance for the lifting or pulling motion is increased only.

Isokinetic — pulling speed remains constant, but resistance change based on pace of movement

Chain — the further into the lift, the heavier the resistance gets.

How to change resistance modes.

When in a class, pause the workout.

Select the button in the top left that shows the current resistance mode.

Select your resistance mode and tap out of the Resistance Mode container. You should see that the Resistance Mode has updated to your preference. The new mode will apply as soon as you resume your workout.



APP INSTRUCTIONS (cont'd.)

WIFI CONNECTION

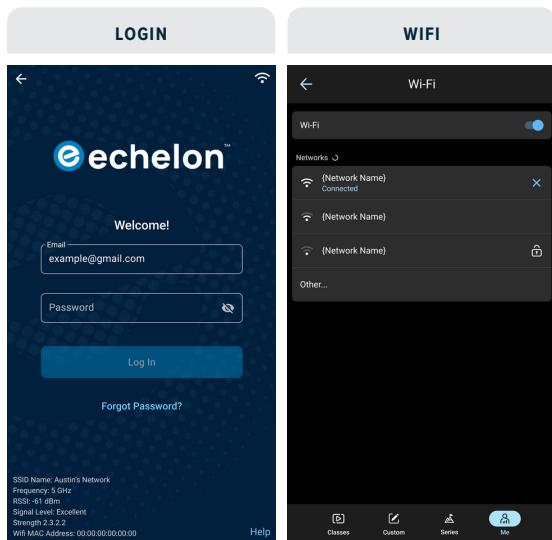

Before logging in:

Tap the WiFi icon in the upper right corner to enter the WiFi page.
Select your network to connect.



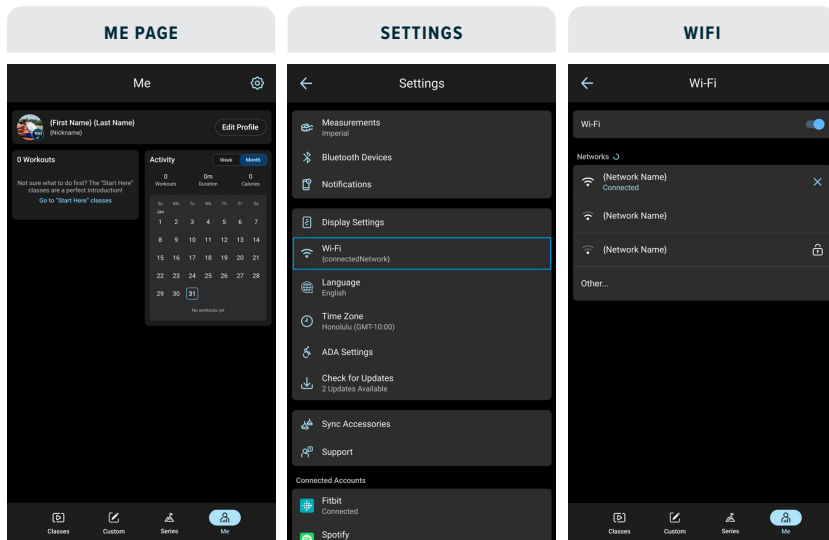

Already logged in:

Tap the 'Me' icon in the bottom menu bar to enter the 'Me' page. Tap the Settings gear icon in the upper right corner to enter the Settings page. Tap WiFi and select your network.



APP INSTRUCTIONS (cont'd.)

BLUETOOTH® CONNECTION

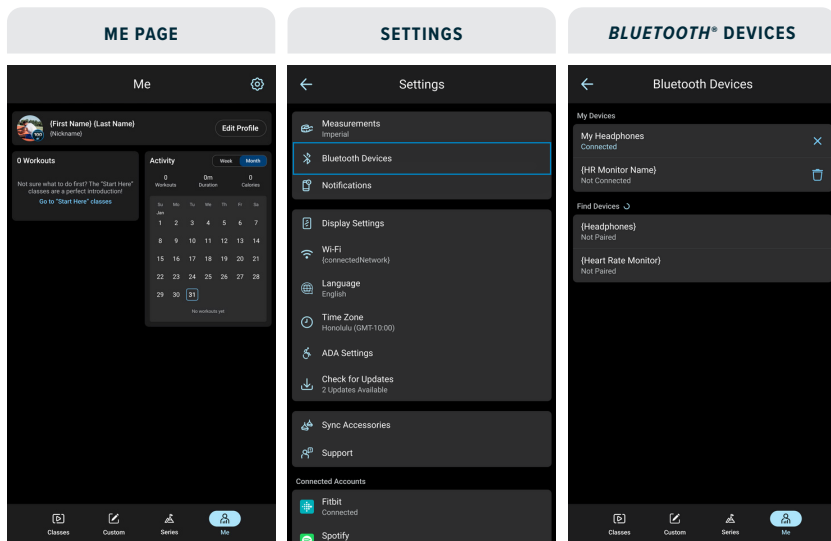

Tap the 'Me' icon in the bottom menu bar to enter the 'Me' page. Tap the Settings gear icon in the upper right corner to enter the Settings page. Tap **Bluetooth®** Devices and select your **Bluetooth®** device to connect.



SMART ACCESSORIES CONNECTION

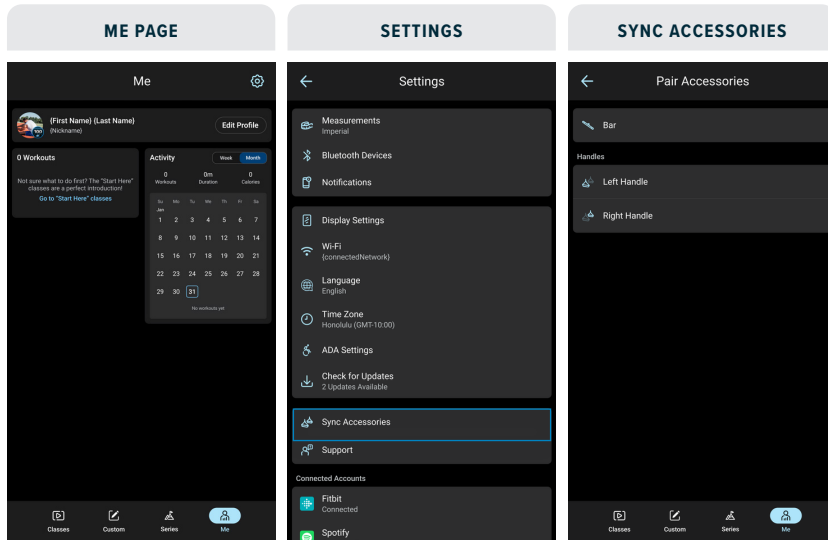

Tap the 'Me' icon in the bottom menu bar to enter the 'Me' page. Tap the Settings gear icon in the upper right corner to enter the Settings page. Tap 'Sync Accessories' to select and pair the Straight Bar and Handle Grips.



CONNECTING TO THE APP

Connecting to the Echelon Fit® App

1. **Ensure your Echelon® Strength Pro is both powered on.**
 - a. The power cord should be plugged into the wall and the base of the Echelon® Strength Pro.
2. **Log in to the Echelon Fit® App.**
 - a. Use the email and password used to create your membership account, as described on page 26.
 - b. Select user. There may only be one option.
3. **Select a class.**
 - a. We recommend a welcome class, but any class will work.
 - b. Press play.



Daily

1. Power off the Echelon® Strength Pro and clean any high-use areas, like the accessories and console, with a non-acidic cleaner (NO ammonia, chlorine, or alcohol) on a soft cloth. Do not spray cleaning solution directly on the Echelon® Strength Pro as that could ruin any electrical components.
2. Inspect the power cord for damage. If damaged, replace immediately by contacting Customer Service (833-937-2453).
Note: When the Echelon® Strength Pro is not in use, unplug and store the power cord in a secure, dry area and away from children.
3. When the Echelon® Strength Pro is not in use, position the arms so that the accessory attachment end is facing the ground and tucked into the sides of the machine as to not obstruct foot traffic and avoid injury.
4. Inspect the accessory snap hooks for damage. If damaged, replace by contacting Customer Service (833-937-2453).

Weekly

1. Clean the console and arms with non-acidic cleaners and a soft cloth. Cleaners should be applied to the cloth and never sprayed onto the equipment directly.
2. Inspect all the assembled and pre-assembled hardware and tighten or re-secure as-needed. This includes but is not limited to the following:
 - a. Stabilizing Legs
 - b. Accessory Rack



CARE & MAINTENANCE (cont'd)

Weekly (cont'd.)

3. Dust and vacuum the Echelon® Strength Pro and the surrounding area. To clean underneath the Echelon® Strength Pro, turn off the power, and move the Echelon Strength Pro to an alternate location. Return the Echelon Strength Pro to its original location after cleaning.
4. Ensure your app and equipment firmware are up-to-date with the latest versions.
5. Test smart accessory and adjustment functions thoroughly to make sure the device is in proper working order. If a replacements are needed, contact Customer Service (833-937-2453) for replacement. Depending on your strength machine model, some functions may not be available.
 - a. Straight Bar Center Controller
 - b. Handle Grip Buttons
 - c. Up/Down Slide Adjustment Levers
 - d. Lateral Arm Adjustment Sliders
 - e. Horizontal Rotation Adjustment Pins



Monthly

1. Assess the components around the cable pulley. If there is an intense build up of dust or debris, contact our customer service to schedule a technician to properly clean and restore the components before using your Echelon Strength Pro again.
2. Inspect the cables for damage. If damaged, replace by contacting Customer Service (833-937-2453).
3. If you find the column unable to swivel, the motor for the locking pin will require adjustment or lubrication. Using a step ladder, remove the two 6mm bolts from the top cap of the unit to assess the arm locking motor for any issues related to this failure.

Yearly

1. Contact customer service (833-937-2453) if you are experiencing any issues.



CUSTOMER SERVICE

Questions or Concerns

Our members are our priority! If you require assistance or have concerns, please contact our customer service team.

☎ (423) 455-8989

✉ cs@echelonfit.com

Submit a Request:



Warranty Information

Your Echelon® Strength Pro comes with a 1-year parts and labor warranty. Should the need arise, all you need is a proof of purchase and our customer service team will be happy to assist. Additional 1- or 3-year extended warranties are available through customer service.



NOTES



echelon

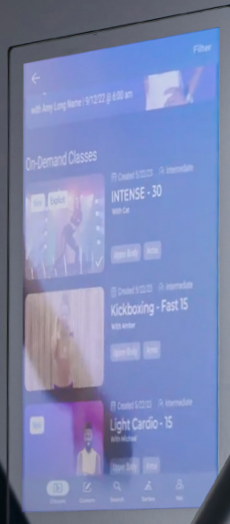

MODELO: ECH-STRENGTHPR
ECHELON FITNESS MULTIMEDIA, LLC
605 CHESTNUT STREET, SUITE 700
CHATTANOOGA, TN 37450

ECHELONFIT.COM / ECHELONCOMMERCIAL.COM



LEA LAS INSTRUCCIONES
ANTES DE USAR

HECHO
EN CHINA



PATENTE
PENDIENTE

REVISADO:
04082024