



eechelon[®]

STRENGTH PRO

INSTRUCTION MANUAL





Lou Lentine
Founder & CEO
Echelon Fitness
Multimedia, LLC

echelon



Hello,

I am Lou Lentine, Founder & CEO of Echelon, and I would like to welcome you to the Echelon community. You've made a great decision for yourself and your family. The Echelon Experience is an innovative combination of fitness products integrated with our state-of-the-art Echelon Fit® app. This brand-new, fitness lifestyle connects your family, friends, the Echelon community, and Echelon instructors together to help you with your fitness goals. With thousands of live and on-demand classes, no matter your schedule or experience, there is always a new and exciting class for you to join.

We embrace your decision to join our Echelon family in the pursuit of living a healthier lifestyle. We are committed to continue engineering cutting edge, world-class fitness products to improve quality of life through workout experiences that make an active lifestyle more accessible and sustainable.

Thank you again for choosing Echelon and I look forward to seeing you in the next live class!

Best personal regards,

A handwritten signature in black ink, appearing to read 'Lou Lentine'.

Lou Lentine
Founder & CEO of Echelon Fitness Multimedia, LLC

FEDERAL COMMUNICATIONS COMMISSION (FCC) STATEMENT

15.21

You are cautioned that changes or modifications not expressly approved by the party responsible for compliance could void the user's authority to operate the equipment.

15.105(A)

This equipment has been tested and found to comply with the limits for a Class A digital device, pursuant to part 15 of the FCC rules. These limits are designed to provide reasonable protection against harmful interference when the equipment is operated in a commercial environment. This equipment generates, uses and can radiate radio frequency energy and, if not installed and used in accordance with the instruction manual, may cause harmful interference to radio communications. Operation of this equipment in a residential area is likely to cause harmful interference in which case the user will be required to correct the interference at their own expense.

FCC RF RADIATION EXPOSURE STATEMENT:

1. This Transmitter must not be co-located or operating in conjunction with any other antenna or transmitter.
2. This equipment complies with RF radiation exposure limits set forth for an uncontrolled environment. This equipment should be installed and operated with a minimum distance of 20 cm between the radiator and your body.

THIS DEVICE COMPLIES WITH PART 15 OF THE FCC RULES. OPERATION IS SUBJECT TO THE FOLLOWING TWO CONDITIONS:

1. This device may not cause harmful interference and
2. This device must accept any interference received, including interference that may cause undesired operation.

INNOVATION, SCIENCE AND ECONOMIC DEVELOPMENT CANADA (ISED) INNOVATION, SCIENCE ET DÉVELOPPEMENT ÉCONOMIQUE CANADA (ISED)

THIS CLASS B DIGITAL APPARATUS COMPLIES WITH CANADIAN ICES-003.

CET APPAREIL NUMÉRIQUE DE CLASSE B EST CONFORME À LA NORME NMB-003.

CANADIAN NOTICE

This device complies with ISED license-exempt RSS standard(s). Operation is subject to the following two conditions:

1. This device may not cause interference, and
2. This device must accept any interference, including interference that may cause undesired operation of the device.

AVIS CANADIEN

Le présent appareil est conforme aux CNR d'ISED applicables aux appareils radio exempts de licence. L'exploitation est autorisée aux deux conditions suivantes :

1. L'appareil ne doit pas produire de brouillage, et
2. L'utilisateur de l'appareil doit accepter tout brouillage radioélectrique subi, même si le brouillage est susceptible d'en compromettre le fonctionnement.

CAUTION: EXPOSURE TO RADIO FREQUENCY RADIATION

1. To comply with the Canadian RF exposure compliance requirements, this device and its antenna must not be co-located or operating in conjunction with any other antenna or transmitter.
2. To comply with RSS 102 RF exposure compliance requirements, a separation distance of at least 20 cm must be maintained between the antenna of this device and all persons.

ATTENTION: EXPOSITION AU RAYONNEMENT RADIOFRÉQUENCE

1. Pour se conformer aux exigences de conformité RF canadienne l'exposition, cet appareil et son antenne ne doivent pas être co-localisés ou fonctionnant en conjonction avec une autre antenne ou transmetteur.
2. Pour se conformer aux exigences de conformité CNR 102 RF exposition, une distance de séparation d'au moins 20 cm doit être maintenue entre l'antenne de cet appareil et toutes les personnes.

echelon
STRENGTH PRO

Echelon Fitness Multimedia, LLC
605 Chestnut Street, Suite 700, Chattanooga, TN 37450
1-833-937-2453 / 1-423-402-8100

Model / Modèle / Modelo: ECH-STRENGTHPR Input / Entrée / Entrada: 120V
FCC ID: 2AWD4-ECHL8077 IC: Frequency / Fréquence / Frecuencia: 50/60Hz
Made in China / Fabriqué en Chine / Hecho en China CAN ICES-3: (B)/NMB-3(B) HVIN: 1.0
Max. Load Per Arm / Charge maximale par bras / Carga máxima por brazo: 130 lbs / 60 kg
Class / Classe / Clase: Max. User Weight/Poids max. utilisateur/Max. peso del usuario: 200kg

This device complies with Part 15 of the FCC Rules. Operation is subject to the following two conditions:
(1) this device may not cause harmful interference, and (2) this device must accept any interference received, including interference that may cause undesired operation of the device.

Cet appareil est conforme à la partie 15 des règles de la FCC. Son fonctionnement est soumis aux deux conditions suivantes: (1) cet appareil peut provoquer des interférences nocives, et (2) cet appareil doit accepter les interférences reçues, y compris celles qui peuvent causer un dysfonctionnement.

Este dispositivo cumple con la Parte 15 de las Reglas de la FCC. El funcionamiento está sujeto a las dos condiciones siguientes: (1) Este dispositivo no pueda causar interferencias dañinas y (2) este dispositivo debe aceptar cualquier interferencia recibida, incluida las interferencias que puedan causar un funcionamiento no deseado del dispositivo.

YVW



Intertek
5020 124

WARNING / AVERTISSEMENT / ADVERTENCIA

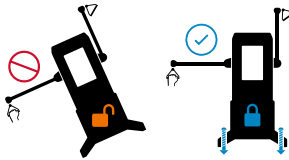

Tip-Over Hazard

Do not operate equipment at maximum weight with an arm fully extended laterally without securing the equipment to the ground. Operating without securing the equipment to the ground may cause tipping and result in injury.

Danger de Basculément

Évitez d'utiliser l'appareil avec la charge maximale avec un bras entièrement déplié latéralement sans avoir fixé l'appareil au sol ou pédoncule. Si l'appareil n'est pas correctement fixé au sol, vous courez le risque de basculer et de vous blesser.

Peligro de Vuelco

No opere el equipo a peso máximo con un brazo totalmente extendido lateralmente sin asegurar el equipo al suelo. Operar sin asegurar el equipo al suelo puede causar que vuelque y resulte en lesiones.

WARNING / AVERTISSEMENT / ADVERTENCIA

RISK OF PERSONAL INJURY. KEEP CHILDREN UNDER THE AGE OF 13 AWAY FROM MACHINE.

Read warnings and instructions must be read and followed.
For consumer/institutional fitness equipment, notice shall also be given to refer to the owner's manual for additional warnings and safety information.

The stationary exercise equipment should only be used after a thorough review of the operation manual (consumer stationary exercise equipment) or under the direct supervision of a trained instructor (institutional stationary exercise equipment).

This equipment operates with very high-powered motors up to 130 lbs. / 60 kg. Negligence is not an excuse for understanding your physical limitations with the equipment. Know your limits and practice safe workout etiquette always when using the equipment.

Please keep away from moving parts at all times. Contact with moving parts may result in serious injury.

Visit <http://echelonfit.zendesk.com/hc/en-us> for more information.

Set up and operate stationary exercise equipment on a solid level surface.

Care should be taken while operating the stationary equipment. When finished with working out, always make sure to fold the arms completely. In to avoid any obstruction to the surrounding area.

Never hang from the arms or any other part of the equipment.

Failure to maintain and care for the equipment could result in serious injury to the user and damage to critical components of the equipment if neglected.

Disconnect power before servicing the equipment (if applicable).

Always service the equipment to the maintenance guidelines as stated in the owner's manual.

WARNING / AVERTISSEMENT / ADVERTENCIA



No Hanging
Do not hang from the arms.
Ne Pas Suspendre
Ne pas suspendre par les bras.
No Colgarse
No se cuelgue de los brazos



No Dragging
Do not drag equipment by the arms.
Ne Pas Faire Glisser
Ne pas faire glisser l'appareil en le tirant par les bras.
No Arrastrar
No arrastre el equipo por los brazos.

RISQUE DE BLESSURE CORPORELLE. EMPÊCHEZ L'ACCÈS À L'APPAREIL AUX ENFANTS DE MOINS DE 13 ANS.

Tous les avertissements et les instructions doivent être lus et suivis. Pour les appareils de remise en forme destinés à un usage privé/professionnel, les utilisateurs doivent être également invités à se reporter au manuel d'utilisation pour les avertissements et les consignes de sécurité supplémentaires.

L'appareil stationnaire ne doit être utilisé qu'après avoir lu attentivement le manuel d'utilisation (appareils stationnaires destinés au grand public) ou sous la surveillance directe d'un instructeur formé (appareils stationnaires destinés aux professionnels).

Cet appareil est doté de moteurs très puissants pouvant atteindre 130 livres (60 kg). Il est important de bien connaître vos limites physiques lorsque vous utilisez l'appareil. Il est également important de ne pas aller au-delà de ses limites et de toujours respecter les consignes de sécurité lorsque vous utilisez l'appareil.

Vous devez rester toujours à distance des pièces en mouvement. Tout contact avec des pièces en mouvement comporte un risque de blessure grave.
Allez sur <http://echelonfit.zendesk.com/hc/en-us> pour en savoir plus.
Régulez et l'appareil de remise en forme stationnaire sur une surface stable et plane.

L'appareil stationnaire doit être utilisé et manipulé avec précaution. Une fois votre séance d'entraînement terminée, vérifiez toujours à régler complètement les bras afin d'éviter d'obstruer l'espace qui se trouve autour.

Évitez toujours de le suspendre par les bras ou d'une autre partie de l'appareil.

Si vous ne prenez pas soin de votre appareil et que vous ne l'entretenez pas, vous vous exposez à un risque de blessure grave et les principaux composants de l'appareil pourraient être endommagés ou présenter un dysfonctionnement en cas de négligence.

Mettez l'appareil hors tension avant de procéder à l'entretien ou à une réparation (le cas échéant).

Veuillez à toujours vous référer aux consignes décrites dans le manuel de l'utilisateur pour réaliser l'entretien de l'appareil.

RIESGO DE LESIONES PERSONALES. MANTENGA A LOS NIÑOS MENORES DE 13 AÑOS ALEJADOS DE LA MÁQUINA.

Deben leerse y seguirse todas las advertencias e instrucciones. En el caso de los equipos de fitness para el consumidor/instituciones, también se debe consultar el manual del propietario para obtener advertencias e información de seguridad adicionales.

El equipo de ejercicio estacionario solo debe usarse después de una revisión exhaustiva del manual de operación (equipo de ejercicio estacionario para el consumidor) o bajo la supervisión directa de un instructor capacitado (equipo de ejercicio estacionario institucional).

Este equipo opera con motores de muy alta potencia hasta 130 lbs. / 60 kg. La negligencia no es excusa para comprender sus limitaciones físicas con el equipo. Conozca sus límites y practique la etiqueta de entrenamiento seguro siempre que use el equipo.

Manténgase alejado de las piezas móviles en todo momento. El contacto con las piezas móviles puede provocar lesiones graves.

Visite <http://echelonfit.zendesk.com/hc/en-us> para más información.
Inicie y opere el equipo de ejercicio estacionario en una superficie sólida y nivelada.

Se debe tener cuidado al operar el equipo estacionario. Cuando termine de hacer ejercicio, siempre asegúrese de plegar los brazos completamente para evitar cualquier obstrucción en el área circundante.

Nunca cuelgue de los brazos o de cualquier otra parte del equipo.
En caso de descuido, la falta de mantenimiento y cuidado del equipo podría provocar lesiones graves al usuario y daños a los componentes críticos del equipo.

Desconecte toda la energía antes de reparar el equipo (si es posible). Siempre de servicio al equipo según las pautas de mantenimiento que se indican en el manual del propietario.



! WARNING | AVERTISSEMENT | ADVERTENCIA

This strength machine is digital strength machine, dedicated to personalized digital training with 100's of movements workouts, including but not limited to shoulder press, cable squat, chest fly, cable kickback, bicep curl, row, ab crunch, bench press, rope pull down, cable twist etc.

! WARNING | AVERTISSEMENT | ADVERTENCIA

To incrementally increase the weight resistance, use only incremental resistance means provided by the manufacturer.

! WARNING | AVERTISSEMENT | ADVERTENCIA

Using the equipment for support during stretching or allowing resistance straps, ropes or other means to be attached to it can result in injury.

! WARNING | AVERTISSEMENT | ADVERTENCIA

Cease exercise if you feel faint or dizzy.

Heart Rate monitoring system may be inaccurate. Over-exercising may result in serious injury or death. If you feel faint, stop exercising immediately.

Keep body, clothing, and fitness accessories clear of all moving parts.

Inspect the equipment before use and do not use if the machine appears damaged or inoperable.

Arrêtez l'exercice si vous vous sentez faible ou étourdi.

Le système de surveillance de la fréquence cardiaque peut être inexacte. Un exercice excessif peut entraîner des blessures graves, voire la mort. Si vous vous sentez faible, arrêtez immédiatement de faire de l'exercice.

Gardez votre corps, vos vêtements et votre forme physique accessoires dégagés de toutes pièces mobiles.

Inspectez l'équipement avant utilisation et faites ne pas utiliser si la machine semble endommagée ou inutilisable.

Deje de hacer ejercicio si se siente débil o mareado.

El sistema de monitoreo de frecuencia cardíaca puede ser incorrecto. El ejercicio excesivo puede provocar lesiones graves o la muerte. Si te sientes débil, deje de hacer ejercicio inmediatamente.

Mantenga el cuerpo, la ropa y la forma física. accesorios libres de todas las piezas móviles.

Inspeccione el equipo antes de usarlo y no utilizar si la máquina parece dañada. o inoperable.

! WARNING | AVERTISSEMENT | ADVERTENCIA

Never allow children on selectorized strength equipment and to supervise the use of selectorized strength equipment by individuals age 13 to 17.



⚠ WARNING | AVERTISSEMENT | ADVERTENCI

When Starting A Workout

Wait 5 seconds for the upper locking pin to engage the column before pulling on the cable.

Au début d'un entraînement

Attendez 5 secondes pour la goupille de verrouillage supérieure pour engager la colonne avant de tirer sur le câble.

Al comenzar un entrenamiento

Espere 5 segundos para que el pasador de bloqueo superior para enganchar la columna antes de tirar del cable.

⚠ WARNING | AVERTISSEMENT | ADVERTENCI

When Stopping/Pausing A Workout

Wait 5 seconds for the upper locking pin to disengage the column before pulling lower pin to adjust arm.

Lors de l'arrêt/de la pause d'un entraînement

Attendez 5 secondes pour la goupille de verrouillage supérieure pour dégager la colonne avant de tirer goupille inférieure pour ajuster le bras.

Al detener o pausar un entrenamiento

Espere 5 segundos para que el pasador de bloqueo superior para desenganchar la columna antes de tirar pasador inferior para ajustar el brazo.



 **WARNING**

 **Keep hands and fingers clear of this area.** 

CONTENTS

⚠ IMPORTANT SAFETY INSTRUCTIONS	9
PARTS LIST	13
ECHELON STRENGTH PRO SPECIFICATIONS	18
ACCESSORIES & PORT SPECIFICATIONS	19
ASSEMBLY	20
USING THE ECHELON STRENGTH PRO	26
Arm Adjustments	21
Workouts	25
App Instructions	27
Connecting to the Echelon Fit® App	38
CARE & MAINTENANCE	39
CUSTOMER SERVICE	40

IMPORTANT SAFETY INSTRUCTIONS

While cleaning your Echelon® Strength Pro, please use a soft rag with mild detergent or water to wipe down the machine. Do not use corrosive chemical liquids which may damage the exterior components of unit.

ONLY use a cleaning agent that is approved for computer displays and touchscreens on the integrated tablet.

When using an electrical appliance, basic precautions should always be followed, including the following:

Read all instructions before using the Echelon® Strength Pro.

FOR COMMERCIAL AND HOUSEHOLD USE.

SAVE THESE INSTRUCTIONS.

DANGER – TO REDUCE THE RISK OF ELECTRIC SHOCK:

Always unplug this appliance from the electrical outlet immediately after using and before cleaning.

WARNING – TO REDUCE THE RISK OF BURNS, FIRE, ELECTRIC SHOCK, OR INJURY TO PERSONS:

1. For best machine performance keep the Echelon® Strength Pro on a dedicated 15amp circuit.
2. An appliance should never be left unattended when plugged in. Unplug from outlet when not in use, and before putting on or taking off parts.
3. Do not operate under blanket or pillow. Excessive heating can occur and cause fire, electric shock, or injury to persons.
4. This appliance is not intended for use by persons with reduced physical, sensory or mental capabilities, or lack of experience and knowledge, unless they have been given supervision or instruction concerning use of the appliance by a person responsible for their safety. **Keep children under the age of 13 away from this machine.**
5. Use this appliance only for its intended use as described in this manual. Do not use attachments not recommended by the manufacturer.
6. Connect this appliance to a properly grounded outlet only. See Grounding Instructions on page 12.
7. Never operate this appliance if it has a damaged cord or plug, if it is not working properly, if it has been dropped or damaged, or dropped into water. Return the appliance to a service center for examination and repair.
8. Do not carry this appliance by supply cord or use cord as a handle.
9. Keep the cord away from heated surfaces.
10. Never operate the appliance with the air openings blocked. Keep the air openings free of lint, hair, and the like.
11. Never drop or insert any object into any opening.
12. Do not use outdoors.



IMPORTANT SAFETY INSTRUCTIONS (cont'd.)

13. Do not operate where aerosol (spray) products are being used or where oxygen is being administered.

14. To disconnect, turn all controls to the off position, then remove plug from outlet.

BEFORE starting any fitness or strength program, consult with your physician or health official. This will ensure that you engage in the proper strength or fitness program for your age and physical condition.

Before using the Echelon® Strength Pro, answer these questions:

- Have you been sick recently?
- Have you had prolonged dizziness recently?
- Have you been out of breath for no reason recently?
- Have you had chest pain recently?
- Do you currently have any injuries preventing you from exercise?
- Are you pregnant?
- Do you have any conditions or reasons you should NOT exercise?
- Are you over 35 years old and physically inactive?
- Have you been told by a doctor that you should NOT exercise?

If you answer “yes” to any of the above questions, you should seek further advice from your doctor prior to using the Echelon® Strength Pro.

Read the user manual fully and follow all instructions. This ensures your safety.

- ALWAYS use the Echelon® Strength Pro on solid, level ground and in a well-lit and ventilated area.

- ALWAYS check the Echelon® Strength Pro for wear or loose components before use.
- NEVER use the Echelon® Strength Pro if it is not properly / completely assembled or is damaged in any way.
- NEVER allow children or pets to play on or around the Echelon® Strength Pro during operation. This helps protect them from injury from moving parts.
- ALWAYS set the Echelon® Strength Pro up properly for your specific body type.
- NEVER use the Echelon® Strength Pro when sick or fatigued.
- ALWAYS warm up / stretch before starting exercise.
- ALWAYS ensure that you have a water bottle filled with at least 12 oz. of water and a towel close by to absorb sweat from your body and the accessories.
- NEVER stand or climb on the arms.
- ALWAYS wear proper attire and footwear that fully covers your feet. Do not wear loose or dangling clothing while using the Echelon® Strength Pro. Long hair should be tied back or tucked away. Ensure that shoelaces are tucked into your shoes.
- ALWAYS keep hands away from moving parts and ensure that hands are safely placed on handlebars during use.
- When the Echelon® Strength Pro is not in use, position the arms so that the accessory attachment end is facing the ground and tucked into the sides of the machine so that they do not obstruct foot traffic and avoid injury.



- NEVER use accessory attachments that have not been recommended by the manufacturer. Using such attachments may cause injury or damage to the Echelon® Strength Pro and will affect the warranty of the Echelon® Strength Pro.
- ALWAYS ensure that the Echelon® Strength Pro is wiped down after each use to keep it sanitary.
- Cleaning and user maintenance shall not be made by children without supervision.

If any problems arise affecting the performance of the Echelon® Strength Pro, contact the manufacturer immediately. Always ensure that parts which undergo wear are checked regularly.

This safety information and user manual do not replace the need to be alert and to use common sense when using the Echelon® Strength Pro!

Avoid any chemicals (cleaning or otherwise) that could degrade nylon when sanitizing the equipment. Including, but not limited to, any solutions containing the following chemicals: Citric Acid, Acetic Acid, Alcohols, Calcium Chloride, Hypo Chlorite, Bromine Liquids, Diacetone & other derivatives.

When not using the Echelon® Strength Pro, unplug the unit and store the plug in a hard-to-reach area away from children or mentally handicapped individuals.

Warnings and Safety

1. Keep hair, body, and clothing free and clear of all moving parts.
2. the safety level of the equipment can be maintained only if it is examined regularly for damage and wear, e.g. ropes, pulleys, connection points.
3. Incorrect or excessive training might result in injuries to health.
4. Inspect the machine before use, including machine and accessories conditions, handle grip, rope grip, straight bar, ankle strap, their connections. Do not use if the machine or any component is worn, damaged, or inoperable. Refer to CARE & Maintenance chapter for more details.
5. The safety and integrity designed into the machine can only be maintained when the treadmill is regularly examined for damage and repaired. It is the sole responsibility of the user/owner or facility operator to ensure that regular maintenance is performed. Worn or damaged components shall be replaced immediately, or the treadmill removed from service until the repair is made. Only manufacturer-supplied or-approved components shall be used to maintain and repair the machine.
6. The safety level of the equipment can be maintained only if it is examined regularly for damage and wear.
7. The Strength Pro is digital weight devices, which is not use traditional weight plate; but please follow your own workout capabilities to select proper electronic weights for safe workout, increase weight bit by bit, don't make big adjustments before your body adapt to the strength workout. The strength machine can go up to weight 60kg per arm.
8. Make proper connection and use of accessories e.g. handle grip, rope grip, straight bar, ankle strap, which attach to the machine arm; Unproper connections and use during cable stretching or retracting might result in injuries. Always use the accessories approved by manufacture.
9. Prior to use, follow the professional guide from gym coach for proper machine use. Read fully the user manual.



Warnings and Safety

10. Please refer to the arm adjustment chapter for proper adjustment prior to use. Or follow the professional guide from gym coach.
11. Supervise the use of the equipment by individuals age 13 to 17.
12. Cease exercise if you feel faint or dizzy.
13. Do not exceed maximum user weight 200KG.
14. The Strength Pro is anchored to the floor, please contact professional technicians for proper floor ground procedures, do not handle by person without professional guidance, which might result in injuries. For anchor steps, please refer to step 1. Each concrete sleeve anchor M10 x 80 can withstand minimum 940KG load on 150# concrete type under hole depth 50mm; the tensile force might vary on different concrete.
15. **WARNING!** Heart rate monitoring systems may be inaccurate. Over exercising may result in serious injury or death. If you feel faint stop exercising immediately
16. Ask local distributor to handle any issue or provide service. It's not allowed to dismantle the components personally. The personal adjustment devices without professional guide might left projecting or component change, they could interfere with the user's movement or proper machine use.
17. The total machine weight: 185KG, total assembly area: 355x280xH222 cm. workout area: 235x170cm
18. The free area shall be not less than 0,6 m greater than the training area in the directions from which the equipment is accessed. The free area must also include the area for emergency dismount.

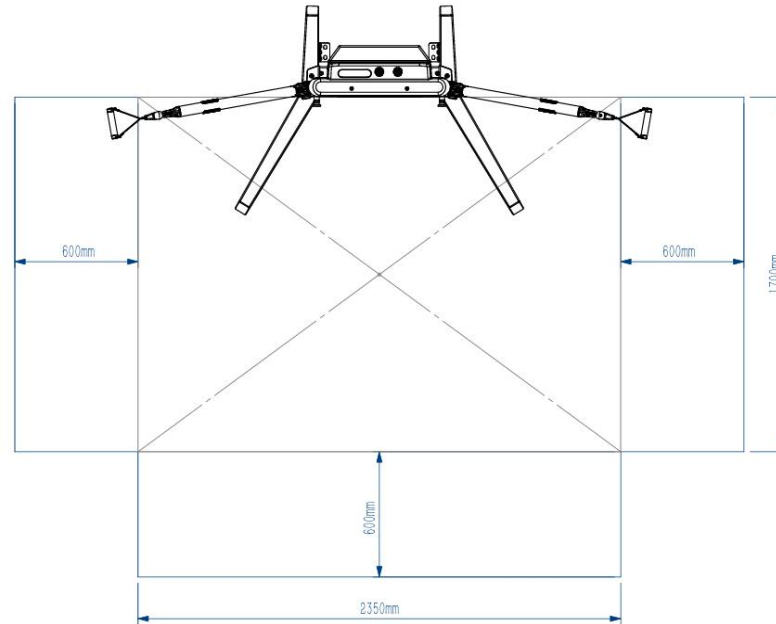

Warnings and Safety

- The actual area for access and passage shall be the responsibility of the facility and should take into account this training envelope and any required local codes or regulations.
- The training equipment shall only be used in areas where access, supervision and control is specifically regulated by the owner.
- The machine meets industry standards for stability when used for its intended purpose in accordance with the instructions provided by the manufacturer. Using the machine for support during stretching or allowing resistance straps, ropes, or other means to be attached to it may result in serious injury.
- Read all warnings posted on the machine.
- It is the facility owner's responsibility to properly instruct users on the proper operation of the equipment and to warn them of the potential hazards



IMPORTANT SAFETY INSTRUCTIONS (cont'd.)

GROUNDING INSTRUCTIONS

This product must be grounded. If it should malfunction or breakdown, grounding provides a path of least resistance for electric current to reduce the risk of electric shock. This product is equipped with a cord having an equipment-grounding conductor and a grounding plug. The plug must be plugged into an appropriate outlet that is properly installed and grounded in accordance with all local codes and ordinances.

DANGER – Improper connection of the equipment-grounding conductor can result in a risk of electric shock. Check with a qualified electrician or serviceman if you are in doubt as to whether the product is properly grounded. Do not modify the plug provided with the product.

- a. If it will not fit the outlet, have a proper outlet installed by a qualified electrician.

For use in the USA, products are designed to operate on a nominal 120-V circuit and have a grounding plug that looks like the plug illustrated in sketch A. Make sure that the product is connected to an outlet having the same configuration as the plug. No adapter should be used with this product.

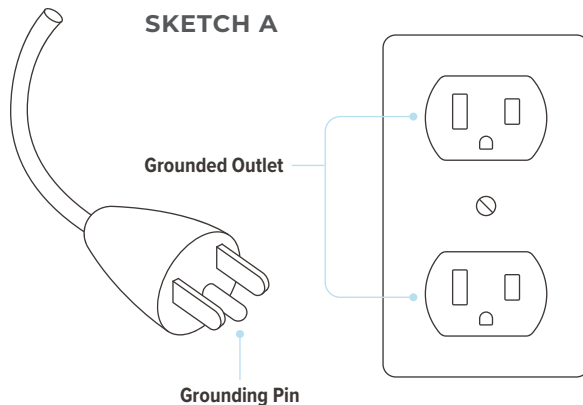

INCLUDES

1. Strength Machine
2. Right Leg (Weighted)
3. Left Leg (Weighted)
4. Accessory Rack
5. Snap Hook ×2
6. Accessories (pg. 19)
Handle Grips
Ankle Strap
Straight Bar
Rope Grip
7. Power Cord (Not Pictured)
8. Hardware Kit (Pg. 14)

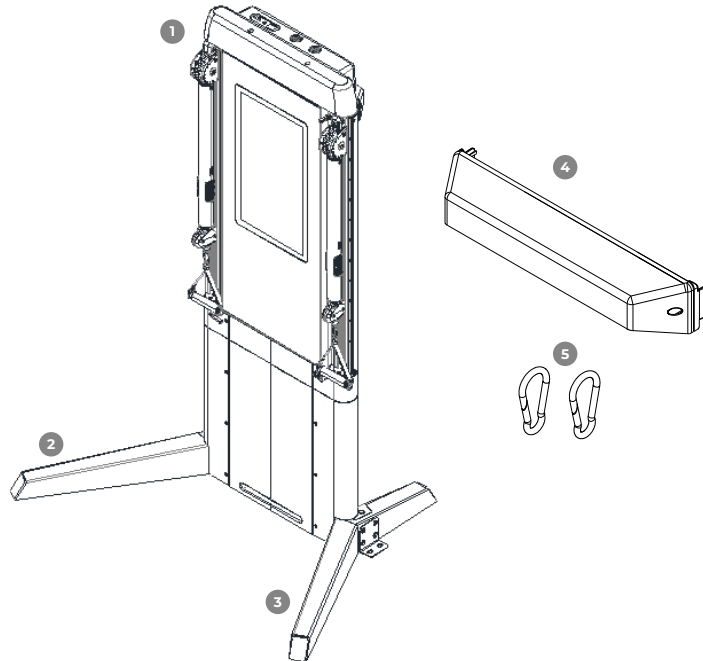

PARTS LIST

No.	Description	Specification	QTY
A	Enclosure frame		
A01	Enclosure frame		1
A02	Left arm rotary shaft		1
A03	Right arm rotary shaft		1
A04	Hex large flat head half tooth bolt	M8×45×20	8
A05	Flat washer	Φ8	8
A06	Hex lock nut	M8	8
A07	Pulley	Φ50×Φ10×22	2
A08	Hex large flat head half tooth bolt	M10×40×20	4
A09	Flat washer	Φ10	4
A10	Hex lock nut	M10	10
A11	Limit bush	Φ10×22×M6	4
A12	Hex large flat head full tooth bolt	M6×12	8
A13	C-shaped holder		2
A14	TFT panel holder		4
A15	Hex large flat head full tooth bolt	M8×10	4
A16	Pin shaft	φ14×85	2
A17	Slot shaft	φ6×21	2
A18	E-shaped circlip for shaft	Φ5	4
A19	Connecting piece assembly		1
A20	Connecting piece	φ10×208	1
A21	Circular connecting piece	∅20×φ28	1
A22	Hex headless full tooth bolt	M5×10	1
A23	Screw	M5×10×φ6×16	4
A24	Motor		1
A25	Motor connecting plate		1
A26	Cross recessed large flat head full tooth bolt	M4×8	8
A27	Microswitch		2
A28	Cross recessed pan head full tooth bolt	M3×18	4
A29	Hex lock nut	M3	4
A30	Square plug	30×60×11.5	2
A31	Double hole gasket		1
A32	Pulley	φ75×Φ10×22	2
B10	Hex cylinder head full tooth bolt	M5×10	2
A34	Mount bracket		1
A35	Flat washer	Φ5	2
A36	TFT mount bracket		1
A37	Hex nut	M10	6
A38	Cross recessed pan head tapping screws	ST4×10	3
A39	Hex large flat head full tooth bolt	M8 x 20	6
A40	Ground wire		1
A41	Cross recessed large flat head self-tapping screw	ST5 x 15	1
A42	Locking washer	Φ5	1
A43	Elastic washer	Φ5	1
F18	Cross recessed pan head full tooth bolt	M4 x 10	4

B	Motor assembly		
B01	Motor weld assembly		1
A15	Hex large flat head full tooth bolt	M8×10	2
B02	Hex large flat head full tooth bolt	M10×20	2
B03	Hex large flat head full tooth bolt	M10×45	2
A10	Hex lock nut	M10	4
B04	Fan		4
B05	Braking resistor	40R 500W	1
B06	Power supply bracket		1
B07	Cross recessed large flat head full tooth bolt	M3×6	2
B08	Hex cylindrical head full tooth bolt	M5×15	18
B09	Hex lock nut	M5	4
B10	Hex cylindrical head full tooth bolt	M5×10	10
B11	60KG servo motor	Upper	1
B12	60KG servo motor	Lower	1
B13	Hex cylindrical head half tooth bolt	M6×115×20	16
B14	Hex lock nut	M6	16
B15	Driver assembly		1
B16	Driver power cord		1
A35	Flat washer	Φ5	8
B17	Hex cylinder head full tooth bolt	M4 x 10	16
C	Arm		
C01	Deep groove ball bearing	6004-ZZ	4
C02	Connecting part		4
C03	Metal plate		2
C04	Guide rail-left		1
C05	Cross recessed countersunk head full tooth bolt	M4×8	20
C06	Hex cylindrical head full tooth bolt	M8×10	8
C07	Hex flat head full tooth bolt	M8×16	8
C08	Screw cap	M8	8
C09	Screw cap	M5	10
C10	Adjusting gear	∅20×Φ50	2
C11	Pull pin shaft	φ17 9×85	2
C12	Hex flat end set bolt	M5×5	8
C13	Pull pin cap	Hex 25×10	2
C14	Pull pin head	Φ40×20×M10	2
C15	Spring	Φ1×Φ13×67	4
C16	Arm assembly		2
C17	Steel cable	φ25×450	2
C18	Guide rail-right		1
C19	Adjust teeth	∅20×Φ50	2
C21	Snap hole plug	Φ10	4
C22	Pull pin connecting piece		2
C23	Hex lock nut	M5	2
C24	Cross recessed cylindrical head variable diameter bolt	M5×6-Φ4×3	2
C25	Adjust slider1L		1

C26	Adjust slider1R		1
C27	Adjust slider2		2
C28	Round head cross pointed tail tapping screw	ST3.5×16mm	4
C29	Sliding positioning assembly		2
C30	Pull pin shaft	Φ17.8×62	2
C31	Connecting rod	11×36.5×15	2
C32	Small shaft	Φ5×17	2
C33	Torsion spring	Φ15.5×29×33.9	2
C34	E-shaped circlip for shaft	Φ4	4
C35	Hex cylindrical head full tooth bolt	M5×10	2
C36	Cross recessed pan head full tooth bolt	M5×6	2
C37	Adjusting shaft	Φ10×55.5	2
C38	Bush	Φ16×Φ10.2×5	4
C39	E-shaped circlip for shaft	Φ8	4
C40	Cross recessed pan head full tooth bolt	M5×15	2
C41	Pulley	φ40×φ10×12	4
C42	Screw	M10×55	2
C43	Disc washer	Φ20×Φ10×11.0	4
C44	D-hole gasket	t1.5×Φ10.4×Φ23	8
C45	Hex lock thin nut	M10×8	2
A11	Limit bush	Φ10×22×M6	6
C46	Hex large flat head full tooth bolt	M6×10	16
C47	Eccentric shaft	Φ14×30.5	4
A10	Hex lock nut	M10	4
C48	Deep groove ball bearing	6200-ZZ	12
C49	Front rotary part	165×101.9×30.3	2
C50	Rear rotary part	165×101.9×37.1	2
C51	7-shaped knob	60×16×21	2
C52	Hex cylindrical head full tooth bolt	M5×12	12
C54	Deep groove ball bearing	6905ZZ	2
C55	Circlip for shaft	Φ25	2
A07	Pulley	Φ50×Φ10×22	4
C56	Wrist housing for pulley	108×85×27.3	4
C57	Hex countersunk head full tooth bolt	M6×15	8
C58	Housing for snap hook	Φ37×50	2
C59	Hex cylindrical head full tooth bolt	M5×15	4
C60	Snap hook	Φ7×70	2
C61	Cable	6+6.27	2
C62	Washer		8



PARTS LIST

D	Base		
D01	Left leg with weight		1
D02	Right leg with weight		1
D03	Square foot pad	50×100×15	6
D04	Hex large flat head full tooth bolt	M10×10	12
E	Console		
E01	TF1 panel		1
E02	Hex large flat head full tooth bolt	M5×10	8
E03	EVA	15.0×390×70	1
E04	Smart bar module		1
E05	Smart handle		2
F	Plastic		
F01	Side cover	1105×110×56	2
F02	Hex large flat head full tooth bolt	M5×25	10
F03	Front cover	1103×505×32.5	1
F04	Acrylic plate for panel	1081.9×464×3.0	1
F05	Screw	M5×10×φ6×4	6
F06	Hex cylindrical head full tooth bolt	M6×10	4
F07	Top cover	690×169×110	1
F08	Fan connecting plate	11.5×75×65	2
F09	Cross recessed large flat head tapping screw	ST3×10	8
F10	Hex cylindrical head full tooth bolt	M8×16	2
F11	Front lower cover	700×449.8×26.8	1
F12	Rear lower cover	700×449.6×19.8	1
F13	Right lower cover	700×164×145.4	1
F14	Left lower cover	700×164×145.4	1
F15	Cross recessed large flat head full tooth bolt	M5×15	4
F16	M4 Screw buckle		16
F17	Hex countersunk head full tooth screw	M4×12	16
F18	Cross recessed large flat head full tooth bolt	M4×10	8
F19	Rear cover	546×400×14.5	2
F20	Cross recessed large flat head tapping screw	ST5×15	8
F21	Accessory rack cover	501.3×119×87	1
F22	Accessory rack plate	13.0×487×65	1
F23	Accessory rack	433×43	1
F24	Cross recessed countersunk head tapping screw	ST4×15	4
F25	Cross recessed countersunk head full tooth bolt	M5×16	2
F26	Hex lock nut	M5	2
F27	Rear end cover	65.5×45×38.2	2
F28	EVA	15.0×25	2
F29	Top cover left block	33.3×30.7×10.9	1
F30	Top cover right block	33.3×30.7×10.9	1
F31	Acrylic support plate		1
F32	Cross recessed self-tapping screw	ST4 x 10	14
F33	Flat washer	φ12×φ4.5×11.0	4

G	System		
G12	Power socket		1
G13	Cross recessed countersunk head tapping screw	ST3×10	2
G15	Rocker switch		1
G18	Power switch		1
G19	Cross recessed large flat head full tooth screw	M3×6	2
G20	USB cable		2
G21	Network cable		1
G22	Cross recessed large flat head full tooth bolt	M3×10	6
G23	Line block		1
G24	Fan		2
G25	Cross recessed pan head full tooth bolt	M4×16	8
G26	Hex lock nut	M4	8
F18	Cross recessed pan head full tooth bolt	M4×10	2
H	Accessories		
H01	Smart bar	φ35×1050	1
H02	Ankle strap	590×105×8	1
H03	Rope	φ28×φ65×640	1
H04	Metal plate to ground	14.0×101×90	2
H05	Button battery	2032	3
L	Hardware kit		
L01	Hex large flat head full tooth bolt	M10×15	8
L02	Hex countersunk head full tooth bolt	M10×95	8
L03	L-shaped wrench	M12×17×50	1
L04	Cross recessed pan head full tooth bolt	M5×20	2
L05	Spring washer	φ10	6
A09	Flat washer	φ10	6
L06	Concrete sleeve anchor	M10×80	4
L07	L-shaped hex wrench	6×40×120	1
L08	Cross open-ended wrench	14×17×75	1
L09	L-shaped wrench	5×35×85S	1
Others			
DY01	Servo drive system		1
DY02	Reset switch		1
DY03	Inductor		1
DY04	Filter		1

	Erp board for 220V		
JN01	ERP board		1
F18	Cross recessed pan head full tooth bolt	M4 x 10	4
JN02	Power line		1
JN03	Power line		1
JN04	AV plate power line		1
JN05	Spring		1
JN06	Magnetic pulley		1
JN07	Sensor sleeve	16×15×13	1
JN08	Hex headless full tooth bolt	M5 x 10	1



HARDWARE PACK

Do not open sections of hardware pack until they are needed.

Part No.

- L Hardware Kit (2)
- L01 Hex Large Flat Head Full Tooth Bolt (8) M10×15
- L02 Hex Countersunk Head Full Tooth Bolt (8) M10×95
- L03 L-Shaped Wrench M2×17×50
- L04 Cross Recessed Pan Head Full Tooth Bolt (2) M5×20
- L05 Spring Washer (6) Φ 10
- A09 Flat Washer (6) Φ 10
- L06 Concrete Sleeve Anchor (4) M10×80
- L07 L-Shaped Hex Wrench (1) 6×40×120
- L08 Cross Open-Ended Wrench (1) 14×17×75
- L09 L-Shaped Wrench (1) 5×35×85

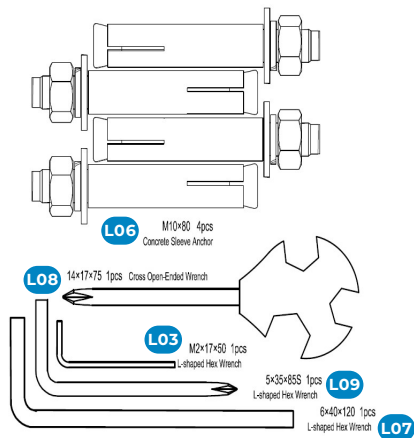
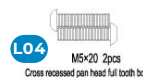
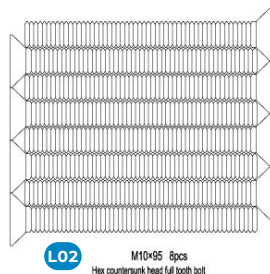
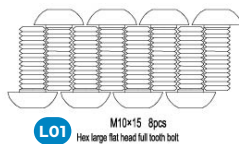

Definitions

\varnothing = Diameter



echelon

Hi! Welcome back! You're logged in as [User Name]

On-Demand Classes

- Power Cardio 30 minutes
- INTENSE - 30
- Kickboxing - Fast 15
- Light Cardio - 15

echelon

STRENGTH PRO SPECIFICATIONS



For replacement parts,
refer to the MASTER
PARTS LIST on page 15.

