

Owner's Manual

Retain this owner's manual for future reference
Read and follow all instructions in this owner's manual

THANK YOU

Thanks for purchasing this product. The product will help you keep fitter, healthier and better in a very easy way. Read and follow all warnings and instructions. For consumer fitness equipment, ensure that proper instructions are obtained prior to use.

IMPORTANT SAFETY INSTRUCTION

- **Care should be taken in mounting or dismounting the treadmill.**
Before mounting or dismounting, bring the machine to a complete stop.
- **Read all instructions before using the treadmill**
For HOUSEHOLD USE ONLY.
SAVE THESE INSTRUCTIONS.
- When using an electrical appliance, basic precautions should always be followed, including the following: Read all instructions before using (this appliance).
- This treadmill is designed for home use for jogging, running workout purpose; Don't use the treadmill for other exercises which has not relation to treadmill.
- Place the treadmill indoors to avoid any water and no heavy stuff.
- The treadmill shall be installed on a stable and levelled base.
- When using the fitness device, wear comfortable clothing and preferably sports or aerobic shoes.
- **Keep Children away from the treadmill to avoid any accident.**
- Prior to use, inspect the treadmill to ensure there is no incorrect, worn, or loose components and all components are in good condition and tighten properly. Refer to treadmill maintenance in last chapter for more information.
- Refer to treadmill maintenance keep the top side of the moving surface clean and dry.
- Refer to treadmill maintenance to replace defective components immediately and/or keep the equipment out of use until repair and pay special attention to components most susceptible to wear.
- Refer to treadmill maintenance for method of adjusting the tension and the lateral position of the running surface.
- The safety and integrity designed into the machine can only be maintained when the treadmill is regularly examined for damage and repaired. It is the sole responsibility of the user/owner or facility operator to ensure that regular maintenance is performed. Worn or damaged components shall be replaced immediately, or the

treadmill removed from service until the repair is made. Only manufacturer-supplied or-approved components shall be used to maintain and repair the treadmill.

- The safety level of the equipment can be maintained only if it is examined regularly for damage and wear.
- No overload to give damages to motor, controller, roller and running belt . Make routine maintenance to the treadmill.
- Keep less dust indoors and keep a certain extent of humidity to avoid interference of console and controller.
- For home use treadmill, keep the treadmill continuous running no more than 2 hours. Indoor use, class HC.
- Keep good air circulation when running.
- The recommended minimum clearance required around each treadmill for access to and passage around shall be 500 mm (19.7 in.) on each side of the treadmill. There shall be 2000x1000mm safe space at the treadmill end when running.
- The minimum clearance area behind the treadmill shall be: 2.0 m (78.7 in.). This clearance shall encompass the entire width of the treadmill or the entire length of a row of treadmills. This clearance zone shall be free of all obstructions.
- Read, understand, and test the emergency stop procedures before use. Refer to how to use emergency key chapter for more information.
- Do not exceed maximum user weight 130KG.
- Stop running if any discomfort and consult the doctor.
- “WARNING! Heart rate monitoring systems may be inaccurate. Over exercising may result in serious injury or death. If you feel faint stop exercising immediately”;
- Keep the silicone oil bottle out of reach from children and avoid eating by mistake.
- After workout, don't jump out of the treadmill directly, so to prevent accident.
- Pull out of the power plug gently from the socket.
- Correct biomechanical positioning of the user on treadmill is important for healthy workout. For correct workout suggestions, please refer to HOW TO USE THE PRODUCT chapter. Injuries to health may result from incorrect or excessive training.
- During workout, stop use the machine if anything wrong and cut the power immediately.

-
- The value of the A-weighted emission sound pressure level at the trainer's ear: 68.4dB.
 - Noise emission under load is higher than without load.
 - Ask local distributor to handle any issue or provide service. It's not allowed to dismantle the components personally. If any of the adjustment devices are left projecting, they could interfere with the user's movement.
 - This treadmill is 120KGS.
 - DANGER – To reduce the risk of electric shock: Always unplug this appliance from the electrical outlet immediately after using and before cleaning.
 - WARNING – To reduce the risk of burns, fire, electric shock, or injury to persons:
 - 1) An appliance should never be left unattended when plugged in. Unplug from outlet when not in use, and before putting on or taking off parts.
 - 2) Do not operate under blanket or pillow. Excessive heating can occur and cause fire, electric shock, or injury to persons.
 - 3) This appliance is not intended for use by persons with reduced physical, sensory or mental capabilities, or lack of experience and knowledge, unless they have been given supervision or instruction concerning use of the appliance by a person responsible for their safety. Keep children under the age of 13 away from this machine.
 - 4) Use this appliance only for its intended use as described in this manual. Do not use attachments not recommended by the manufacturer.
 - 5) Never operate this appliance if it has a damaged cord or plug, if it is not working properly, if it has been dropped or damaged, or dropped into water. Return the appliance to a service center for examination and repair.
 - 6) Do not carry this appliance by supply cord or use cord as a handle.
 - 7) Keep the cord away from heated surfaces.
 - 8) Never operate the appliance with the air openings blocked. Keep the air openings free of lint, hair, and the like.
 - 9) Never drop or insert any object into any opening.
 - 10) Do not use outdoors.
 - 11) Do not operate where aerosol (spray) products are being used or where oxygen is being administered.

-
- 12) To disconnect, turn all controls to the off position, then remove plug from outlet.
 - CAUTION – To Reduce The Risk Of Injury From Moving Parts - Unplug Before Servicing.
 - WARNING – To Reduce the Risk of Electric Shock – Unplug Before Cleaning or Servicing
 - CAUTION - Risk of Injury to Persons – To Avoid Injury, use extreme caution when stepping onto or off of a moving belt. Read Instruction Manual Before Using.
 - For household use only.
 - Connect this appliance to a properly grounded outlet only. See Grounding Instructions.
 - SAVE THESE INSTRUCTION

Caution: The user is cautioned that changes or modifications not expressly approved by the party responsible for compliance could void the user's authority to operate the equipment.

This device complies with Part 15 of the FCC Rules. Operation is subject to the following two conditions: (1) this device may not cause harmful interference, and (2) this device must accept any interference received, including interference that may cause undesired operation.

NOTE: This equipment has been tested and found to comply with the limits for a Class B digital device, pursuant to Part 15 of the FCC Rules. These limits are designed to provide reasonable protection against harmful interference in a residential installation. This equipment generates, uses and can radiate radio frequency energy and, if not installed and used in accordance with the instructions, may cause harmful interference to radio communications. However, there is no guarantee that interference will not occur in a particular installation.

If this equipment does cause harmful interference to radio or television reception, which can be determined by turning the equipment off and on, the user is encouraged to try to correct the interference by one or more of the following measures:

- Reorient or relocate the receiving antenna.
- Increase the separation between the equipment and receiver.
- Connect the equipment into an outlet on a circuit different from that to which the receiver is connected.
- Consult the dealer or an experienced radio/TV technician for help.

FCC Radiation Exposure Statement

This equipment complies with FCC radiation exposure limits set forth for an

uncontrolled environment. This equipment should be installed and operated with a minimum distance of 20cm between the radiator and your body.

This transmitter must not be co-located or operating in conjunction with any other antenna or transmitter.

USE GUIDE

- Always connect the appliance to a socket with a grounded circuit and no other appliances connected to it. It is recommended not to use any extension cords.
- Ensure the treadmill stable on the ground before use.
- Check if its function normal or not before running.
- Stand on two side rails when the treadmill starts.
- Attach the safety key to your clothes when running to control any emergency.
- Press “start” button to get the treadmill started.
- Follow the running belt with left leg to do pre-running. Only when you feel it right, then to run with two legs on the treadmill with proper running posture.
- ONLY FOR ONE PERSON. Overload not allowed.
- Adjust speed if necessary.
- After running, pull out the safety key or press “stop” button to get it stopped.
- After running, remember to turn off the power and pull out the plug.
- When you are running on the treadmill, if you feel uncomfortable, please stop to run immediately and consult doctors.
- When you are assembling or running the machine, please ensure no person or pets around it.

GROUNDING INSTRUCTIONS

- This product must be grounded. If it should malfunction or breakdown, grounding provides a path of least resistance for electric current to reduce the risk of electric shock. This product is equipped with a cord having an equipment-grounding conductor and a grounding plug. The plug must be plugged into an appropriate outlet

that is properly installed and grounded in accordance with all local codes and ordinances.

- **DANGER-** Improper connection of the equipment-grounding conductor can result in a risk of electric shock. Check with a qualified electrician or serviceman if you are in doubt as to whether the product is properly grounded. Do not modify the plug provided with the product if it will not fit the outlet, have a proper outlet installed by a qualified electrician.
- This product is for use on nominal 120-V circuit, and has a grounding plug that looks like the plug illustrated in sketch A in below picture. The adaptor is not allowed for use.

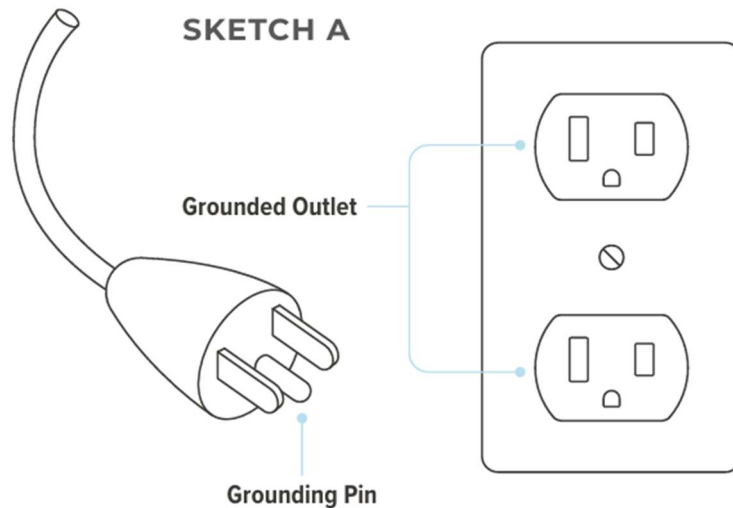

DANGER !

To reduce accidents or do harm to any others, check following rule.

- ◆ Ensure zipping up before running.
- ◆ Don't wear the clothes, which is easily hooked.
- ◆ Keep power cord away from hot objects.
- ◆ Keep children away from the treadmill.

-
- ◆ If anything goes wrong, you can make push-up on the handlebar, leave both leg from the running belt, and jump from outside the treadmill.
 - ◆ Cut off the power before moving the treadmill.
 - ◆ Don't open motor and roller cover unless professional technician.
 - ◆ This machine is used under 10A circuit.
 - ◆ Make sure that only one person at a time uses the fitness device.
 - ◆ The treadmill HRC devices is not professional medical devices, and may not be as exact as medical devices, its results are for reference only.

Stop exercising immediately, should you feel unwell or if you feel pain in your joints or muscles. In particular, keep an eye on how your body is responding to the exercise program. Dizziness is a sign that you are exercising too intensively with the device. At the first signs of dizziness, lay down on the ground until you feel better.

INAPPROPRIATE USER

Following patients under treatment need to get use of the treadmill after approval of professional doctor.

- ◆ The person with backache or used to get hurt in the leg, waist, neck.
- ◆ The patient with arthritis deformans, rheumatism or gout.
- ◆ The patient with osteoporosis.
- ◆ The patient with a bad circulatory system like heart disease, vascular disorders and vascular hypertension.
- ◆ The patient with respiratory disturbance.
- ◆ The patient with Artificial heart rhythm problem.
- ◆ The patient with malignant tumors.

-
- ◆ The patient with thrombosis.
 - ◆ The patient with diabetes-caused perceptual disturbance.
 - ◆ The person with skin injury.
 - ◆ The patient with a high fever above 38° C.
 - ◆ The person with bent back bone.
 - ◆ The person with pregnancy or in (menstrual) period.
 - ◆ The person feels uncomfortable.
 - ◆ The person sleeps badly.

PROHIBITION

Don't use treadmill in following cases, or it will lead to fire or get damaged.

- ◆ Do not use the machine when some cover or inner component is not complete
- ◆ Do not jump on or jump off the treadmill
- ◆ Do not use or place it outdoors or rainy or humid environment.
- ◆ Do not use or place it under strong sunlight or high-temperature environment.
- ◆ Do not use when there is damage or loose to the power cord or socket
- ◆ Do not twist or damage the power cord or put something heavy on it .
- ◆ Do not use by two persons at the same time. Keep other people far away from it.
- ◆ Do not let the disabled or somebody who cannot operate the machine to use .
- ◆ Do not dismantle the machine personally.

Attention!

- ◆ Do not take strong exercise if you a lazy fitter on common days .
- ◆ Do not work out just after meal or when you feel tired ,flaccid or uncomfortable.
- ◆ Do not use it when you are drunk .
- ◆ Do not use when your pocket is full of hard things.
- ◆ Do not have any dust, waste, and water on the power plug.

-
- ◆ Do not use with damp hands.
 - ◆ Do not pull out or plug in the power cord, otherwise you can be hurt or get an electric shock.

PLUG OUT TIPS

In following cases, please pull out the power cord from the socket, otherwise can lead to fire as dust and humidity will get the power cord insulation worse OR you can be hurt or get an electric shock.

- ◆ The treadmill is not used
- ◆ When the treadmill is under maintenance
- ◆ Can not start or appear abnormal
- ◆ Have the power failure.
- ◆ When you are plugging out, don't hold the power cord only. You should hold the power cord head and then plug out.
- ◆ The treadmill shall be grounded to get less electric shock as grounding provide narrowest channel to the resistance. Please follow local rule to assemble the socket and plug in a proper way. Or you can consult a professional technician. Adaptor socket is not allowed.

Warning labels

echelon
STRIDE-50-RCX

Echelon Fitness Multimedia, LLC
605 Chestnut Street, Suite 700, Chattanooga, TN 37450
1-833-937-2453 / 1-423-402-9010

Model / Modèle / Modelo: STRIDE-RCX

FCC ID: 2AWD4-ECHL7747

Made in China / Fabriqué en Chine / Hecho en China

Max. User Weight / Poids max. utilisateur /

Max. peso del usuario: 285 lbs / 130 kg

Motor / Moteur : 2.0CHP, 3.0PHP

Input / Entrée / Entrada: 120V~60Hz

Power / Alimentation / Potencia: 1500W

Current / Courant / Energía: 13A

Class / Classe / Clase: HC

This device complies with Part 15 of the FCC Rules. Operation is subject to the following two conditions: (1) this device may not cause harmful interference, and (2) this device must accept any interference received, including interference that may cause undesired operation of the device.

Cet appareil est conforme à la partie 15 des règles de la FCC. Son fonctionnement est soumis aux deux conditions suivantes: (1) cet appareil peut provoquer des interférences nocives, et (2) cet appareil doit accepter les interférences reçues, y compris celles qui peuvent causer un dysfonctionnement.

Este dispositivo cumple con la Parte 15 de las Reglas de la FCC. El funcionamiento está sujeto a las dos condiciones siguientes: (1) Este dispositivo no pueda causar interferencias dañinas y (2) este dispositivo debe aceptar cualquier interferencia recibida, incluida la interferencia que puedan causar un funcionamiento no deseado del dispositivo.

SERIAL # BARCODE

YYYY

SERIAL #

Conforms to UL STD. 1647,
Certified to CSA STD. C22.2 NO. 68

Conforme à UL STD. 1647
Certifié à CSA STD. C22.2 NO. 68

Cumple con UL STD. 1647
Certificado según CSA STD. C22.2 NO. 68

For consumer use only.

Exclusivement destiné
à une usage privé.

Solo para uso del consumidor.



WARNING | AVERTISSEMENT | ADVERTENCIA

KEEP CHILDREN AWAY FROM MACHINE

Risk of Injury to Persons - To Avoid Injury, use extreme caution when stepping onto or off of a moving belt.

Read Instruction Manual Before Using.

Read and follow all warnings and instructions. For consumer equipment, ensure that proper instructions are obtained prior to use.

To reduce the risk of injury from moving parts, unplug before servicing.

To reduce the risk of electric shock, unplug before cleaning or servicing.

CAUTION:
Risk of personal injury. Keep children under the age of 13 away from machine.

Always wait for the treadmill to come to a complete stop before resuming or ending a workout.

TENIR LES ENFANTS À L'ÉCART DE LA MACHINE.

Risque de blessures corporelles - Pour éviter les blessures, soyez extrêmement prudent lorsque vous montez ou descendez d'une courroie en mouvement.

Lire le manuel d'instructions avant utilisation.

Avant l'utilisation, lire tous les avertissements et directives et, dans le cas d'équipement grand public, obtenir tous les directives appropriées.

Pour limiter le risque de blessure liée aux pièces en mouvement. Débranchez avant de réaliser l'entretien.

Pour limiter le risque de choc électrique. Débranchez avant de nettoyer ou de réaliser l'entretien.

ATTENTION:
Risque de blessure. Tenez les enfants de moins de 13 ans à distance de la machine. Attendez toujours le tapis roulant s'arrêter complètement avant de reprendre ou de terminer un entraînement.

MANTENGA A LOS NIÑOS ALEJADOS DE LA MAQUINA.

Riesgo de lesiones a las personas: para evitar lesiones, tenga mucho cuidado al subir o bajar de una correa en movimiento. Lea el manual de instrucciones antes de usar

Lea y siga todas las advertencias e instrucciones y, en el caso de equipos de consumo, obtenga las instrucciones adecuadas antes de su uso.

Para reducir el riesgo de lesiones por piezas móviles. Desenchufa antes de reparar.

Para reducir el riesgo de descarga eléctrica. Desenchufe antes de limpiar o reparar.

PRECAUCIÓN:
Riesgo de lesiones personales. Mantenga a los niños menores de 13 años lejos de la máquina.

Espera siempre a la cinta de correr detenerse por completo antes de continuar o terminar un entrenamiento.

WARNING | AVERTISSEMENT | ADVERTENCIA

Cease exercise if you feel faint or dizzy.

Heart Rate monitoring system may be inaccurate. Over-exercising may result in serious injury or death. If you feel faint, stop exercising immediately.

Keep body, clothing, and fitness accessories clear of all moving parts.

Inspect the equipment before use and do not use if the machine appears damaged or inoperable.

Arrêtez l'exercice si vous sentez faible ou étourdi.

Le système de surveillance de la fréquence cardiaque peut être inexacte. Un exercice excessif peut entraîner des blessures graves, voire la mort. Si vous vous sentez faible, arrêtez immédiatement de faire de l'exercice.

Gardez votre corps, vos vêtements et votre forme physique accessoires dégageés de toutes pièces mobiles.

Inspectez l'équipement avant utilisation et faites ne pas utiliser si la machine semble endommagée ou inutilisable.

Deje de hacer ejercicio si se siente débil o mareado.

El sistema de monitoreo de frecuencia cardíaca puede ser incorrecto. El ejercicio excesivo puede provocar lesiones graves o la muerte. Si te sientes débil, deje de hacer ejercicio inmediatamente.

Mantenga el cuerpo, la ropa y la forma física. accesorios libres de todas las piezas móviles.

Inspeccione el equipo antes de usarlo y no No utilizar si la máquina parece dañada. o inoperable.

WARNING | AVERTISSEMENT | ADVERTENCIA



REMOVE POWER CORD WHEN NOT IN USE

Remove power cord to avoid damage from transport or storage.

Store power cord out of reach of children.



RETIREZ LE CÂBLE D'ALIMENTATION LORSQUE L'APPAREIL N'EST PAS UTILISÉ

Retirez le câble d'alimentation pour éviter tout dommage lié au transport ou au stockage.

Rangez le cordon d'alimentation hors de portée des enfants.

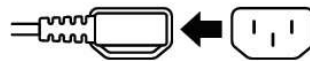

RETIRE EL CABLE DE ALIMENTACIÓN CUANDO NO LO UTILICE

Retire el cable de alimentación para evitar que se dañe durante el transporte o el almacenamiento.

Guarde el cable de alimentación fuera del alcance de los niños.

DANGER | AVERTISSEMENT | PELIGRO

To avoid risk of electric shock, connect this appliance to a properly grounded outlet. DO NOT modify the plug provided with the treadmill. If the plug does not fit the outlet, get a proper outlet installed by a qualified technician.

Pour éviter tout risque de choc électrique, branchez cet appareil sur une prise de courant reliée à la terre. NE MODIFIEZ PAS la fiche fournie avec le tapis roulant. Si la fiche ne rentre pas dans la prise, faites installer unen prise adaptée par un électricien qualifié.

Para evitar el riesgo de descarga eléctrica, conecta este aparato a una toma de corriente adecuadamente conectada a tierra. NO MODIFIQUE el enchufe que viene con la caminadora. Si el enchufe no encaja en el tomacorriente, comunícale con un electricista calificado.

⚠ WARNING | AVERTISSEMENT | ADVERTENCIA

NEEDS LUBRICATION FOR MAINTENANCE
See owner's manual for more information.

L'APPAREIL DOIT ÊTRE GRAISSÉ POUR GARANTIR SON BON FONCTIONNEMENT

Consultez le mode d'emploi pour plus de détails.

NECESITA LUBRICACIÓN PARA MANTENIMIENTO

Vea el manual del propietario para más información.



Belt Drifting Left or Right

Turn Left or Right Adjusting Bolt 1/4 turn clockwise with Allen Wrench until centered.

Courroie dérivant à gauche ou à droite

Tournez le boulon de réglage à gauche ou à droite d'un quart de tour dans le sens des aiguilles d'une montre avec la clé Allen jusqu'à ce qu'il soit centré.

La correa se desplaza hacia la izquierda o hacia la derecha

Gire el perno de ajuste hacia la izquierda o hacia la derecha 1/4 de vuelta en el sentido de las agujas del reloj con una llave Allen hasta que esté centrado.

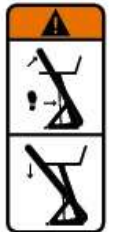

Belt Drifting Left or Right
Turn Left or Right Adjusting Bolt 1/4 turn clockwise with Allen Wrench until centered.
Courroie dérivant à gauche ou à droite
Tournez le boulon de réglage à gauche ou à droite d'un quart de tour dans le sens des aiguilles d'une montre avec la clé Allen jusqu'à ce qu'il soit centré.
La correa se desplaza hacia la izquierda o hacia la derecha
Gire el perno de ajuste hacia la izquierda o hacia la derecha 1/4 de vuelta en el sentido de las agujas del reloj con una llave Allen hasta que esté centrado.



QR code and QR code text.

AVERTISSEMENT | ADVERTENCIA
NEED LUBRICATION FOR MAINTENANCE
See owner's manual for more information.
L'APPAREIL DOIT ÊTRE GRAISSÉ POUR GARANTIR SON BON FONCTIONNEMENT
Consultez le mode d'emploi pour plus de détails.
NECESITA LUBRICACIÓN PARA MANTENIMIENTO
Vea el manual del propietario para más información.



AC120V

AVERTISSEMENT | ADVERTENCIA
NEED LUBRICATION FOR MAINTENANCE
See owner's manual for more information.
L'APPAREIL DOIT ÊTRE GRAISSÉ POUR GARANTIR SON BON FONCTIONNEMENT
Consultez le mode d'emploi pour plus de détails.
NECESITA LUBRICACIÓN PARA MANTENIMIENTO
Vea el manual del propietario para más información.

EXPLODED DRAWING

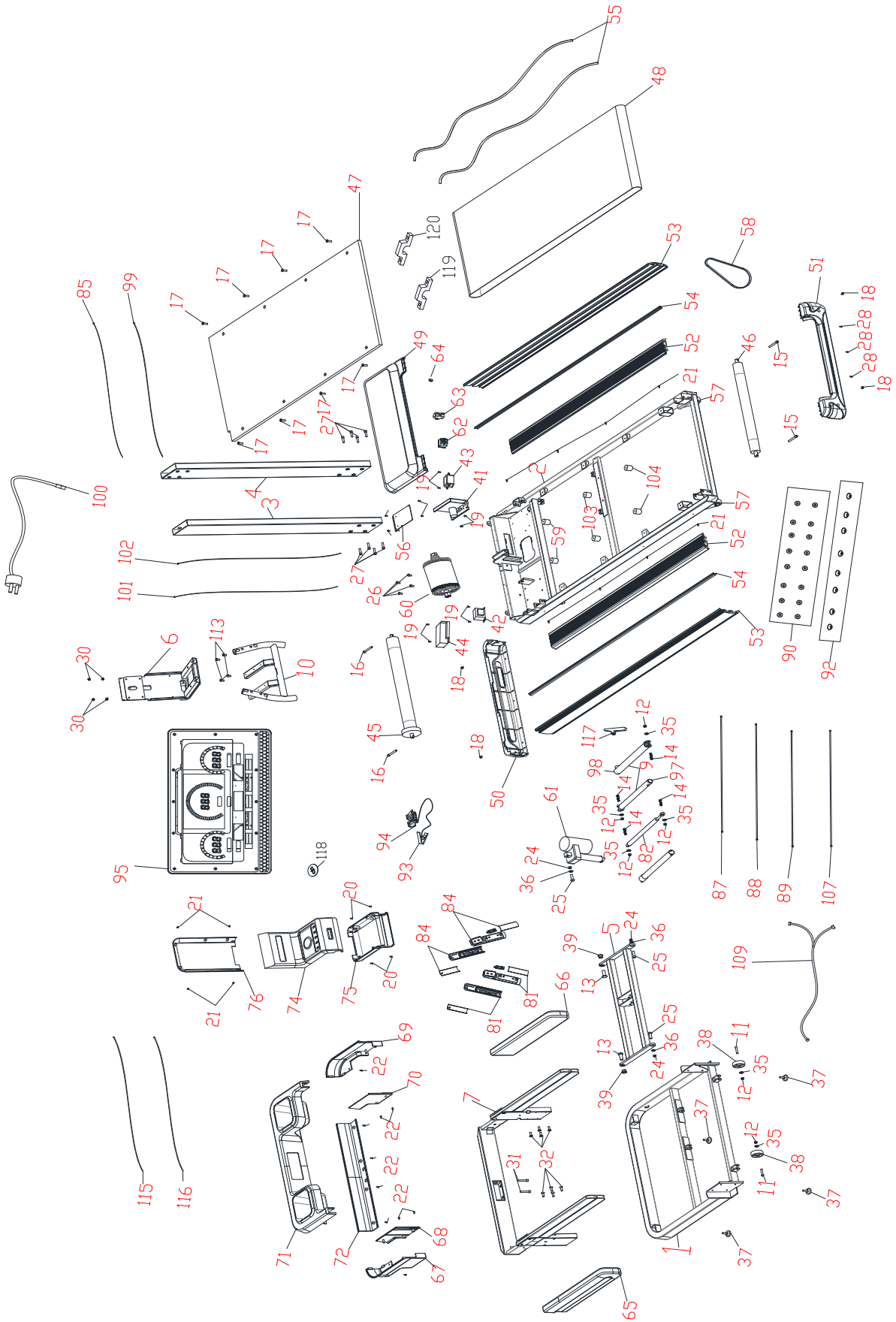

EXPLODED DRAWING CHART

NO.	Description	Specification	QTY
1	Bottom frame		1
2	Main frame		1
3	Left upright		1
4	Right upright		1
5	Incline frame		1
6	Console neck frame		1
7	Handlebar frame		1
9	Ezfit linking parts		1
10	Handle grip		1
11	Allen truss head half thread bolt half thread	M8×50×20	2
12	Hex lock nut	M8	12
13	Allen half thread bolt	M12×Φ14×35×19	2
14	Allen truss head half thread bolt	M8×35×20	4
15	Allen socket head full thread bolt	M8×75	2
16	Allen socket head full thread bolt	M8×60	1
17	Allen flat head full thread bolt	M6×25	10
18	Phillips truss head full thread bolt	M5×10	4
19	Phillips truss head full thread bolt	M4×10	10
20	Phillips flat head self-tapping screw	ST4×15	18
21	Phillips truss head self-tapping screw	ST4×16	10
22	Phillips flat head self-tapping screw	ST3×10	2
23	Allen truss head half thread bolt	M8×40×20	2
24	Hex lock nut	M10	3
25	Allen truss head half thread bolt	M10×65×20	1
26	Allen truss head full thread bolt	M8×25	4
27	Allen socket head full thread bolt	M8×35	8
28	Phillips truss head self-tapping screw	ST4×10	14
29	Phillips truss head self-tapping screw	ST4×12	24
30	Allen pan head full thread bolt	M6×25	4
31	Allen socket head full thread bolt	M8×45	2
32	Allen flat head full thread bolt	M8×25	8
34	Allen truss head half thread bolt	M10×35×20	3
35	Flat washer	Φ8	14
36	Flat washer	Φ10	4
37	Foot pad		4
38	Front wheel		2
39	Powder metallurgy sleeve		2
41	Controller		1
42	Choke		1
43	Filter		1
44	Power adaptor		1
45	Front roller		1
46	Rear roller		1
47	Running deck		1
48	Running belt		1
49	Motor cover		1
50	Front motor cover		1
51	Rear cover		1
52	Foot rail		2

53	Side cover		2
54	LED strip housing		2
55	LED strip		2
56	Choke/filter bracket		1
57	Rear wheel		2
58	Motor belt		1
59	Cushion 1		4
60	Brushless motor		1
61	Incline motor		1
62	Power switch		1
63	Reset Switch		1
64	Power cable buckle		1
65	Left PU handlebar		1
66	Right PU handlebar		1
67	Left outer handlebar cover		1
68	Left inner handlebar cover		1
69	Right outer handlebar cover		1
70	Right inner handlebar cover		1
71	Upper tray cover		1
72	Lower tray cover		1
74	Upper dashboard cover		1
75	Lower dashboard cover		1
76	Console neck cover		1
81	Incline handle pulse		1
82	Cylinder		1
84	Speed handle pulse		1
85	Main communication wire (main frame+upright)		1
87	Power communication wire		1
88	Power communication wire		1
89	Power communication wire		1
90	Side rail guider		16
91	Power cable buckle		3
92	Plastic flat pad		8
93	Safety key		1
94	Safety key socket		1
95	LED display		1
97	Inner expansion pipe		1
98	Outer expansion pipe		1
99	LED communication wire (main frame+upright)		1
100	Power cord		1
101	Main communication wire (console)		1
102	LED communication wire (console)		1
103	Cushion1 2		2
104	Cushion1 3		2
107	Power connection wire		1
109	Handle pulse wire		1
111	Display bracket		1
112	Allen truss head bolt	M8×40	2
113	Allen truss head full thread bolt	M8×15	4
114	Display inner bracket		1

115	main communication wire (dashboard)		1
116	LED communication wire (dashboard)		1
117	Pedal lever		1
118	Wireless charging pad		1
119	Motor fixed plate A		1
120	Motor fixed plate B		1

NOTE: We reserve the right to amend the product without prior notice.

TREADMILL STRUCTURE

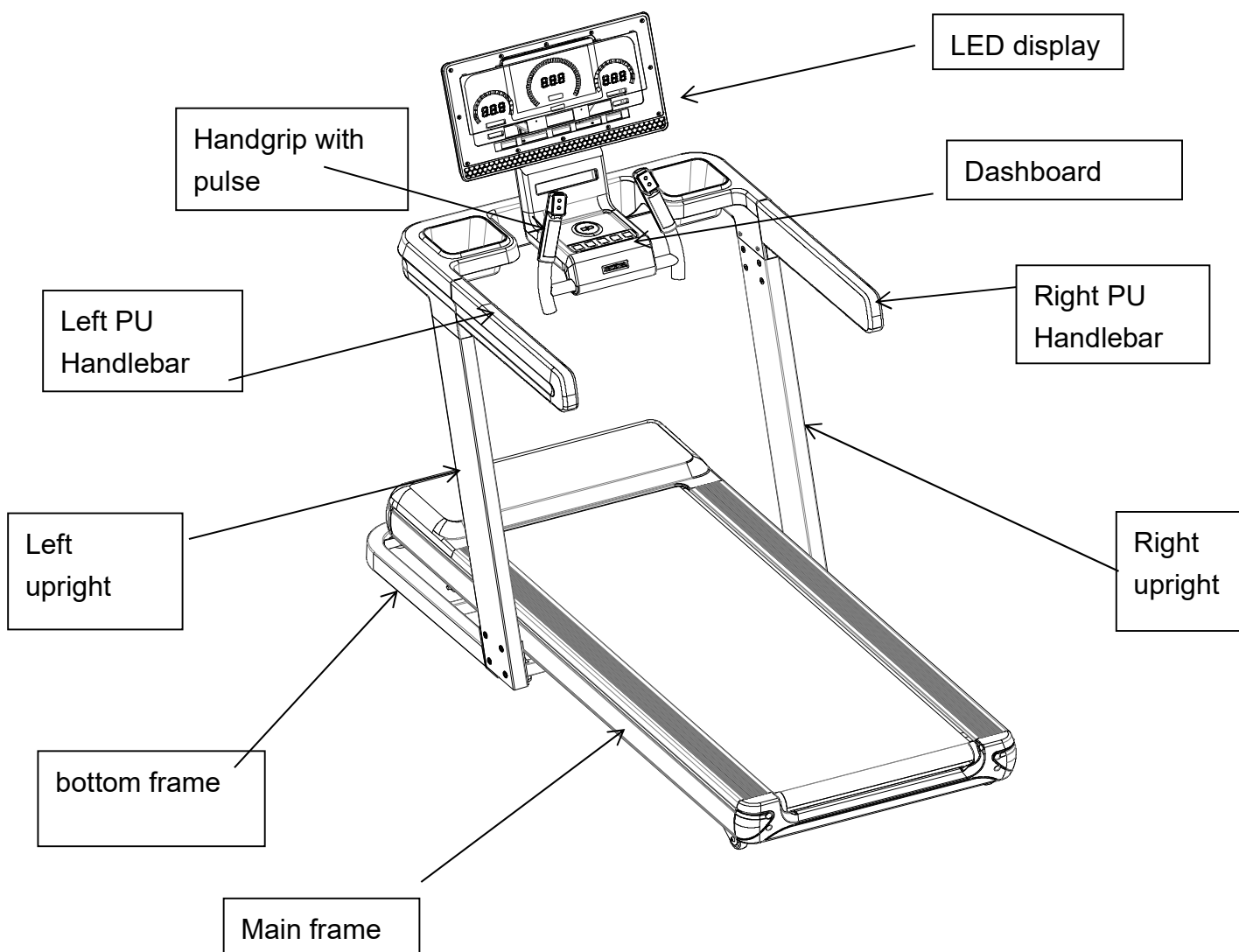

Max. user weight	130KG
Assembly size	In use: 1823*886*1582mm
	Fold: 1107*886*1065mm
Running space	57"x22" (1450*550mm)
Motor	2.0CHP, 3.0PHP
Speed	0.6-12.5mph (1.0-20km/h)

NOTE: WE RESERVE THE RIGHT TO AMEND THE PRODUCT WITHOUT PRIOR NOTICE.

Packing parts

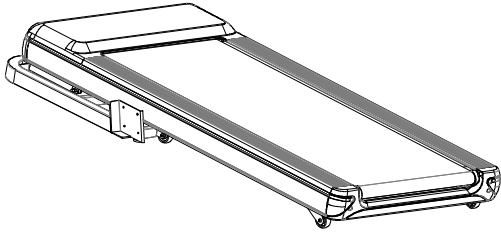

Main frame

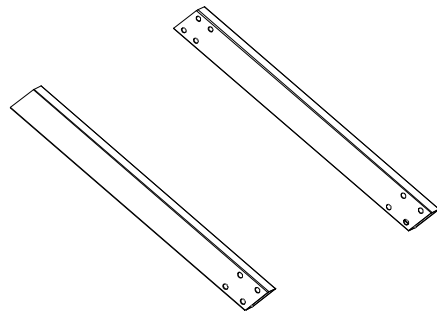

Upright

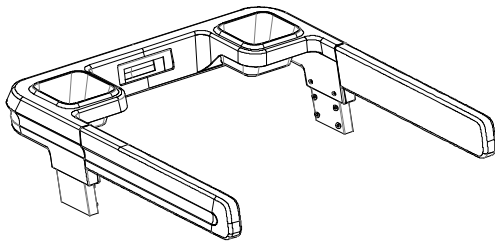

Tray and handlebar

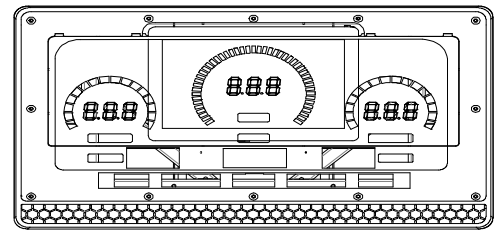

LED display



Silicone
oil bottle

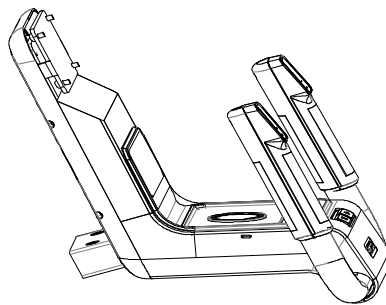

Handgrip
dashboard

Hardware
kit

User
manual

Hardware kit

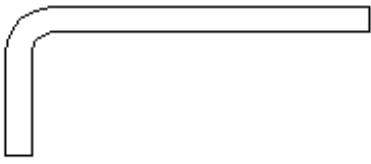

L-shaped wrench
5×30×80

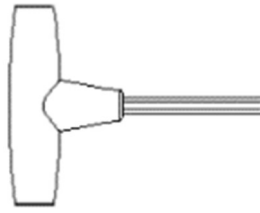

T-shaped wrench
6×80

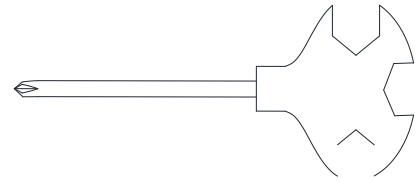

Cross open wrench
14 x 17 x 75

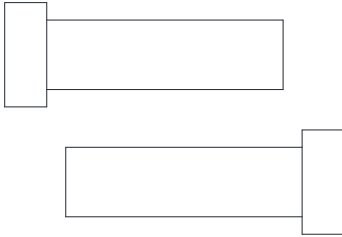

Allen socket head full thread bolt
M8×45 2PCS

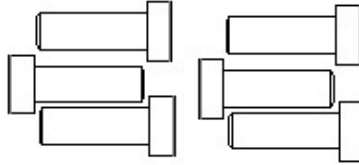

Allen socket head full thread bolt
M8×35 6PCS

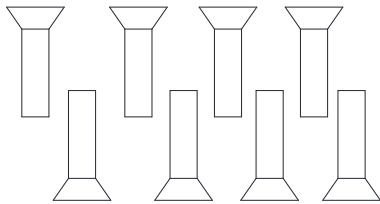

Allen flat head full thread bolt
M8×25 8PCS

Main parts



Motor cover

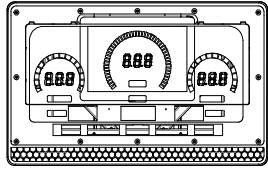

LED display

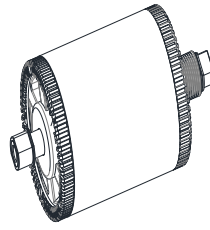

Brushless motor

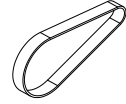

Motor belt

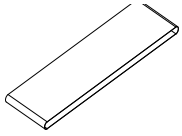

Running belt

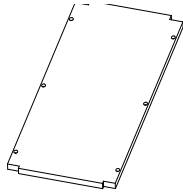

Running deck



Side rail



Rear roller

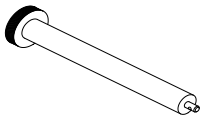

Front roller



Rear cover

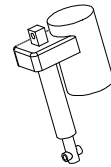

Incline motor

ASSEMBLY INSTRUCTION

Note: Do not plug in power socket before installation completes; Do not remove bands securing running deck to main frame until treadmill is in desired assembly location. Doing so could result in injury.

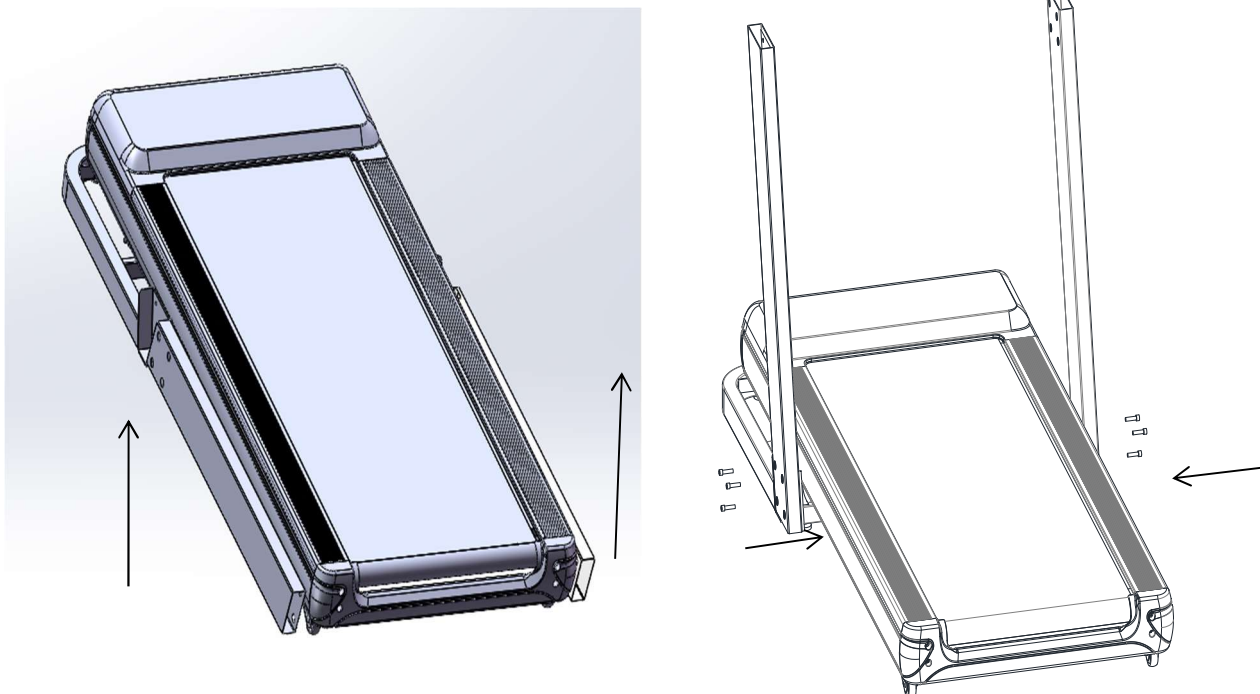

Step 1: Take out the main frame and display from box and put it on the flat floor (As shown). The uprights are attached to the main frame already, only lift both uprights up and lock 6 M8x35 Allen socket head full thread bolt, but don't tighten them.

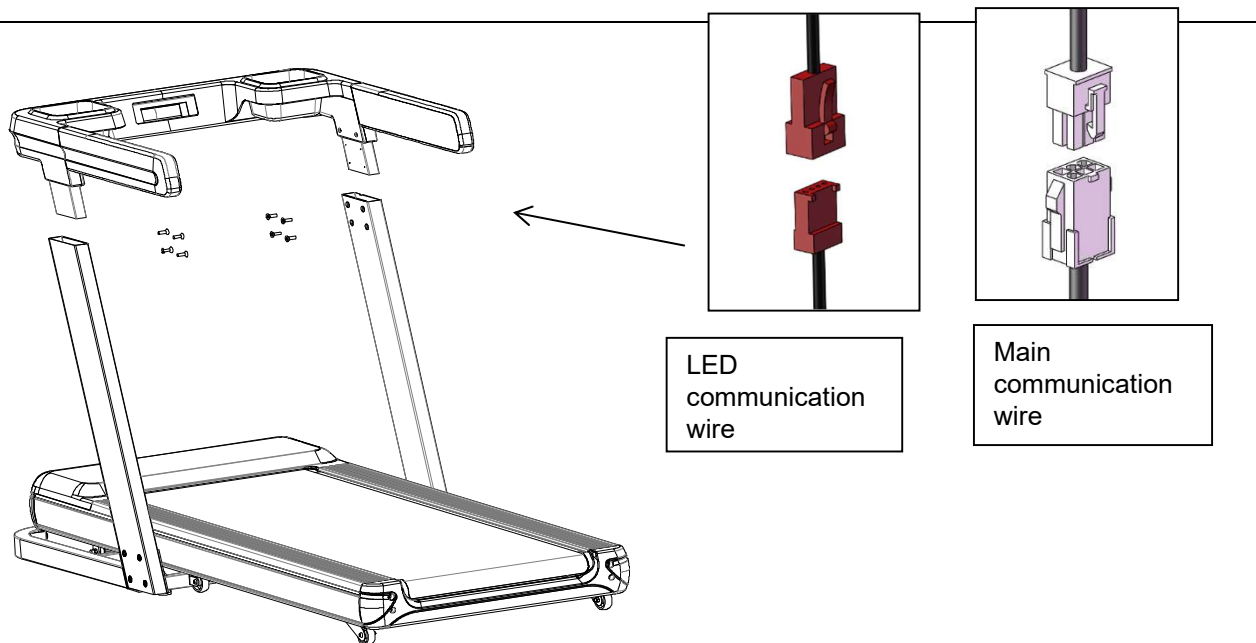

Step 2: Connect the two communication wires between console frame and upright, then put the console frame onto the upright by 8 M8 x 25 Allen flat head full thread bolt, but don't tighten them.

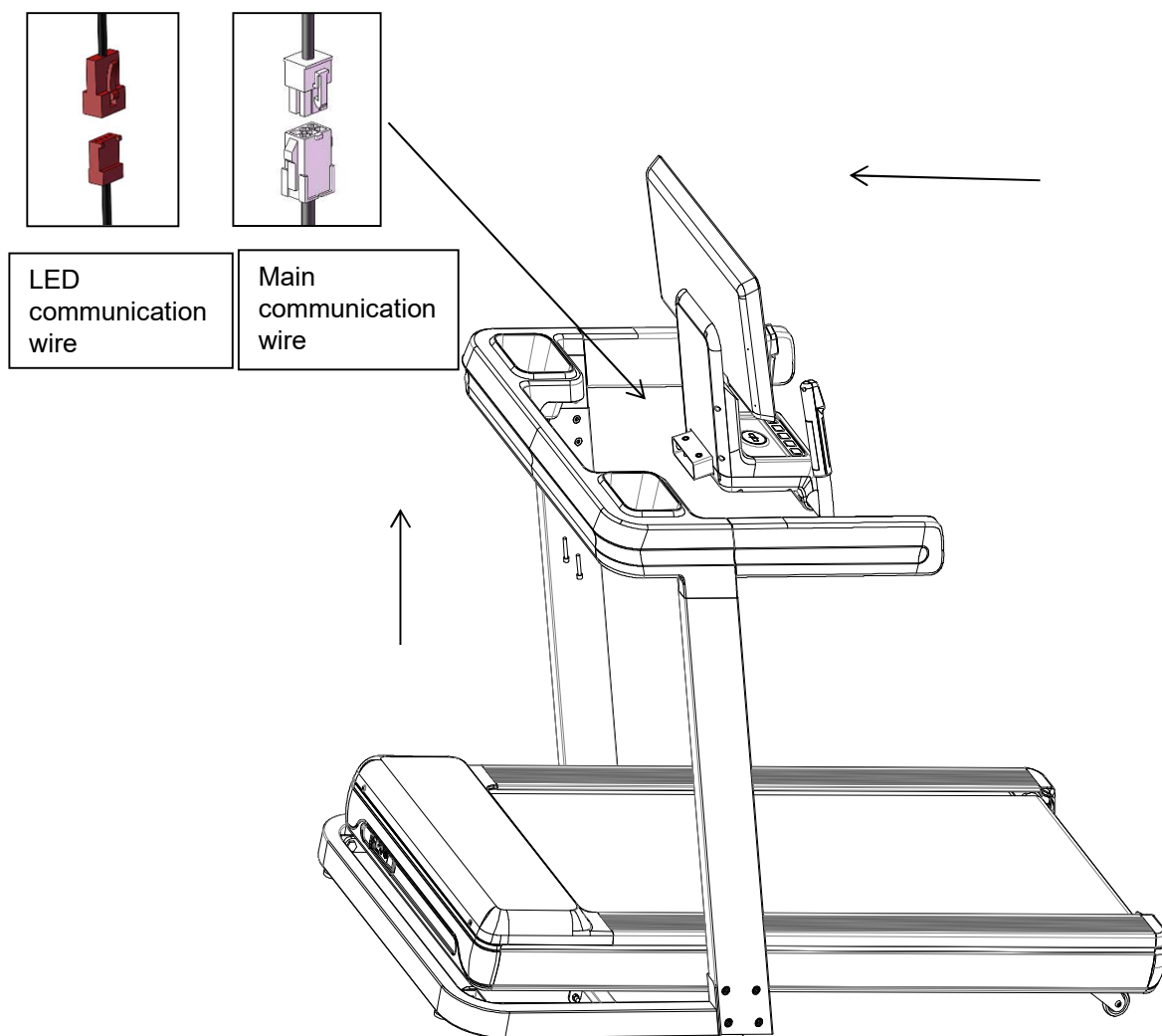

Step3: the LED display is pre-assembled with dashboard. Connect the communication wire, insert the handgrip dashboard into the console frame with 2ea M8 x 45 Allen

socket head full thread bolt, tighten all bolts. The setup is completed.

GENERAL FITNESS TIPS

Warm-Up

Do some warm-up for at least 5 to 10 minutes before every exercise.

Breathe

Make sure you breathe regularly, properly and calmly when exercising.

Exercise Frequency

It should have 48 hours of rest for the same muscles.

Load

Do exercise as per your own condition, can enhance exercise force step by step .In the beginning ,it's normal to get aching pain of muscles. This pain can be removed in the late phase.

Relax

Remember to have some relax at least 5 minutes to do some stretch after running.

Drink and Meal

Start running on the treadmill after 1 hour of your meal.

And you can start your meal after half an hour of finishing exercise. Drink less water and no large drink when running.

Stretching Exercises

A successful exercise session begins with warming up exercises and ends with exercises for cooling down and relaxing. These warming up exercises prepare your body for the subsequent demands made upon it. The cooling down / relaxation period after the exercise session ensures that you do not experience any muscular

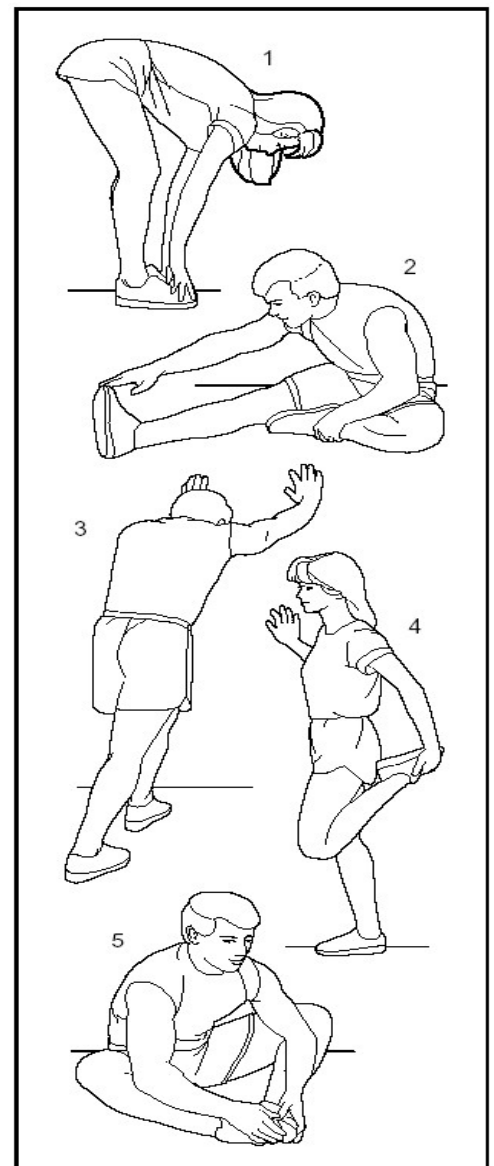

problems. In the following you will find stretching exercise instructions for warming up and cooling down. Please pay attention to the following points:

1. TOUCH TOES

Bend your trunk slowly forwards and try to touch your feet with your hands. Reach down as far as possible to your toes. Maintain this position for 10-15 seconds if possible and relax. Repeat three times. See pic.1

2. EXERCISES FOR THE KNEES

Sit on the floor and place your feet in such a way that your knees are facing outwards. Pull you 10-15 seconds if possible. Repeat three times for each leg . See pic.2

3. EXERCISES FOR THE CALVES/ACHILLES TENDON

Place both hands on the wall and support your full body weight. Then move your left leg backwards and alternate it with your right leg. This stretches the back of the leg. Maintain this position for 10-15 seconds if possible. Repeat this exercise 2 times for each leg. See pic.3

4. EXERCISES FOR THE UPPER THIGH

Support yourself by placing your hand on the wall, then reach down behind you and lift up your right or left foot as close to your buttocks as possible. Feel a comfortable tension in your front upper thigh. Maintain this position for 10-15 seconds if possible and repeat this exercise 2 times for each leg. See pic.4

5. INSIDE UPPER THIGH

Sit on the floor and stretch out your right leg. Bend your left leg and place your foot on your right upper thigh. Now try to reach your right foot with your right arm. Maintain this position for 10-15 seconds if possible. Repeat this exercise 3 times for each leg. See pic.5

CONSOLE KEYPRESS INSTRUCTION



LED panel display



Incline fast key

Speed fast key

Metrics

Incline: 0-15

TIME: 0:00-99.59

PULSE: 0-999

CALORIES: 0-999

SPEED: 0.6-12.5MPH (1.0-20.00 KMH)

DISTANCE: 0-99.9

Incline fast key: level 2/4/6/8

Speed fast key: 2/4/6/8 mph (equals 3.2/6.4/9.6/12.8kmh)

Dashboard keypress

Mode

Program

Stop/
Pause

Start

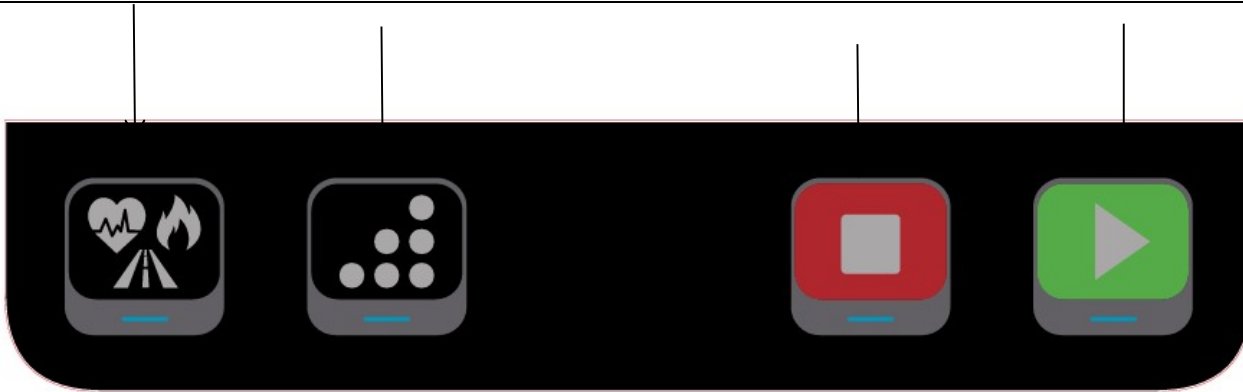

When not connected to Echelon APPs, the LED treadmill can be operated by itself with built-in program and mode:

Program: P1-P10 built-in programs for selection by press this button;

Mode: Press mode key to switch among time, distance and calories to input the target.

Start key: At standby mode without pressing Program or Mode key, Press start key to start to run;

Stop key: when the treadmill runs, press this key to pause the treadmill; press and hold this key to stop the treadmill; at standby, press this key to reset.

Change mph and kmh: unplug the safety key, press and hold **program** and **mode** key at the same time for 3 seconds, the program switches its unit and then reboot, the speed window will show its current unit for 1 seconds. E= metric (kmh), I= imperial (mph)

Note: when connected to Echelon APPs by iPad/mobile by Bluetooth, it can select the Echelon run class to operate the treadmill, instead of using the built-in program and mode on treadmill.

Handgrip keypress

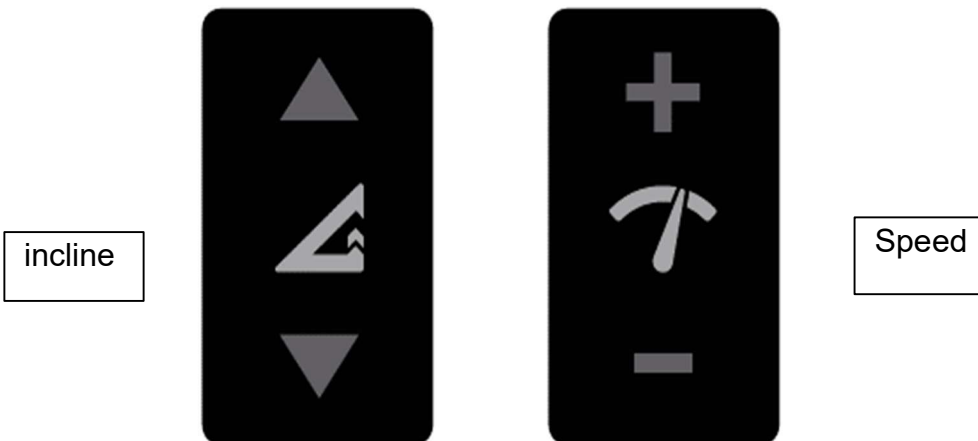

Keypress Button instruction with either LED panel, or connected Echelon APPs by Bluetooth:

Power on treadmill, the LED panel light up, you can either workout under LED panel alone, or log-in Echelon APPs, select your desired classes, click Play, the treadmill will start automatically, enjoy the running joy; when the class end, the treadmill will stop automatically. If you wanna start/pause/stop the treadmill, below manual setting will help:

1. **Start key:** Press start key, there is 3 beeping for countdown, the treadmill starts with the running belt and Red LED on side rail;
2. **Stop key:** Press Stop key, the treadmill pauses, the belt does not run with flash red

and green LED on side rail; Press Start key to restart the treadmill; At pause status, press and hold Stop key, the treadmill stops, the belt does not run with Green LED on foot rail.

3. **Incline key:** click ▲, the incline is adding; click ▼, the incline is decreasing (incline range: 0-15), and it will also display in Echelon APPs;
4. **Speed key:** click + to add the speed; click – to decrease the speed (speed range: 0.6-12.5mph), and it will also display in Echelon APPs.
5. **Safety key:** when the safety key is pulled out, the treadmill stops with flash Red LED; when the safety key is inserted, press Start key or click the blue icon resume workout in APPs to restart the treadmill.
6. **Hand pulse:** when power on, put both hands on the hand pulse, the heart rate will be displayed on PULSE window in LED; If connected to Echelon APPs, it will show in APPS, and LED on side rail will change color following heart rate zone (Note: This value is not used as medical data, only for workout reference.)
7. **LED on side rail off:** the treadmill goes to sleep mode.
8. **Speakers:** It has a pair of speakers over Bluetooth. Connect your player or phone over Bluetooth to the treadmill and play the music.

Below works on Keypress Button instruction by LED treadmill itself, without connecting Echelon APPs:

Target mode

At standby mode, Press Mode key to input training target. The target will count down after the start. Press Mode key to switch among time, distance and calories. Then press UP/DOWN keys of speed or incline to adjust the targets. Once any of the targets, time, distance and calories reach zero, the treadmill will end the work session and stop the motor. Then the treadmill will recover to standby mode. At target mode, anytime press Program key, the treadmill will enter the Program function.

Program

In standby mode, Press Program key to select programs from 1 to 10. The selected program will show at the CALORIES window, the startup incline of the selected program will show at the INCLINE window, and the startup speed of the selected program will show at the SPEED window.

Below are the profiles for each program:

Segment Program		1	2	3	4	5	6	7	8	9	10
P1	SPEED	1.0	3.0	5.0	5.0	5.0	7.0	7.0	7.0	3.0	2.0
	INCLINE	2	2	8	6	6	5	5	6	2	2
P2	SPEED	1.0	3.0	5.0	8.0	5.0	5.0	6.0	8.0	4.0	3.0
	INCLINE	3	3	2	2	8	8	4	4	4	4
P3	SPEED	2.0	3.0	7.0	8.0	5.0	5.0	5.0	8.0	4.0	3.0
	INCLINE	1	2	5	7	7	4	4	6	2	2
P4	SPEED	2.0	2.0	5.0	8.0	8.0	8.0	8.0	5.0	3.0	2.0
	INCLINE	3	3	9	9	9	9	9	6	2	2
P5	SPEED	3.0	4.0	8.0	9.0	10.0	10.0	10.0	7.0	4.0	3.0
	INCLINE	2	2	8	6	6	6	6	6	1	1
P6	SPEED	3.0	4.0	6.0	7.0	7.0	7.0	9.0	10.0	5.0	3.0
	INCLINE	1	8	8	7	7	7	7	5	3	1
P7	SPEED	3.0	4.0	4.0	10.0	4.0	9.0	4.0	11.0	3.0	2.0
	INCLINE	1	1	6	6	6	8	8	10	6	2

P8	SPEED	3.0	5.0	7.0	9.0	3.0	5.0	7.0	5.0	11.0	5.0
	INCLINE	3	3	3	7	7	3	3	3	5	5
P9	SPEED	3.0	7.0	10.0	4.0	7.0	11.0	5.0	4.0	12.0	6.0
	INCLINE	3	6	7	3	8	8	3	8	4	4
P10	SPEED	3.0	5.0	9.0	10.0	6.0	6.0	9.0	6.0	11.0	3.0
	INCLINE	2	7	5	5	8	8	8	8	4	4

The Program has a 30-minute default countdown time. You may adjust the time by pressing UP and DOWN keys.

If you want to quit Program, press STOP to go back to Quick Start. At Program mode, anytime press Mode key, the treadmill will enter the Target function.

HOW TO USE THE PRODUCT

1, Turn the power on, keep the treadmill at its lowest position without incline and check if normal function.

2, Attach the safety key to your clothes by clips.

3, Check and ensure proper function and stability before use.

- Don't stand on the running belt to get it started.
- The correct way to start is standing on both side rails with hands on the handle bar.
- After pressing Start key or click Play in the APPs Class, the treadmill is running at the initial speed of 0.6mph (1km/h)
- Press Speed + key to add speed. (1.6-2.2mph which equals 2.5km/h-3.5km/h, is comfortable speed). With both hands on handlebar, step onto the running belt with both feet one after another, and you will soon keep up with the speed of the running belt.

4, After some minutes, the treadmill can speed up by pressing Speed + key, or speed down by pressing speed - key, while holding the hand bar(speed range: 0.6-12.5mph, which equals, 1-20kmh) It can also incline by pressing Incline ▲ key, or decline by pressing incline ▼ key (incline range: 0-15 level).

5, Press Stop key to stop the treadmill immediately, or wait the class ends and the treadmill stops automatically. Press stop key the 1st time for pause; at Pause status, hold and press the key again to stop.

6, Heart rate testing: After the treadmill is powered on, hold your hands on the hand pulse, then you can see HRC value on the display window. (Note: This value is not used as medical data, only for workout reference.)

HOW TO USE SAFTEY KEY

Put on the safety key; When the safety key connected to treadmill is pulled out, the treadmill will stop and LED shows AA error code. Only when push back the safety key to the treadmill, and press Start key on console again, or click the blue icon Resume

Workout in APPs, the treadmill will run again.



Trouble shooting and maintenance

Treadmill

Item	Reason	Maintenance
Treadmill doesn't work	a no power	Plug into socket
	b safety key isn't in the right position	Insert the safety key back to the safety key socket
	c Open circuit signal system	Check the controller input and signal wire
	d switch off	Place the power switch in the "ON" position.
The running belt does not run smoothly.	a no enough lubrication	Use the Silicone oil
	b running belt too tight	Adjust the running belt tension
Running belt slips	a running belt too loose	Adjust the running belt tension

Console

Item	Reason	Maintenance
System doesn't work	A、 No power	Plug into socket, place the power switch in the "ON" position.
	B、 safety key isn't in the right position	Insert the safety key back to the safety key socket
	C、 transformer isn't inserted right, or transformer is defected	Check and connect the transformer correctly, or replace the transformer
	D、 Open circuit	Check the system input and output terminal and the communication lines
Stop suddenly	A、 Safety key fall off	Insert the safety key back into safety key socket

in a normal state	B、abnormal system	Contact the after-sales team for service
Buttons don't work	A、Some buttons are damaged or invalid	Replace the buttons
	B、All buttons are invalid	1、Replace button board, wires of buttons 2, main board 3 or console
No heart rate data is shown	A、Handle pulse wire isn't assembled well, or handle pulse wire is defected.	Check and connect it well, or replace the handle pulse wire
	B、Console line fault	Replace the console
AA (at all window)	Safety key lost	Plug the safety key back
A1 (at TIME window)	lower control board connection fails.	1. Check if good connection between lower controller and console, and each pin is properly inserted.
		2. Check if any damage cables between lower controller and console, change the cables
		3. Change lower controller or console if above cannot solve
A2 (at TIME Window)	explosion-proof protection	1. Use volt meter to check whether the power supply voltage is lower than 50% of the normal voltage
		2. Check if connecting motor, and reconnect the motor cable.
		3. Check if odor from controller, and change the controller.
A3 (at TIME window)	Abnormal speed sensor	1. Check if speed sensor correct installation
		2. Check if speed sensor in good contact, if wire in good condition
		3. Change the speed sensor
A4 (at TIME window)	Abnormal incline motor	1. Run the incline motor calibration: Unplug the safety key, then hold the STOP key for 3seconds to enter incline calibration. Plug the safety key again, the incline will return to zero after calibration completes.
		2. If still error code, check if the wire is proper connection
		3. Change the incline motor
A5 (at TIME window)	Over current	1. Power off for 20seconds, then power on
		2. If still error code, check if roller proper function, check if the running belt and deck good lubricated
		3. Change the controller

Using instruction:

Treadmill folding and moving:

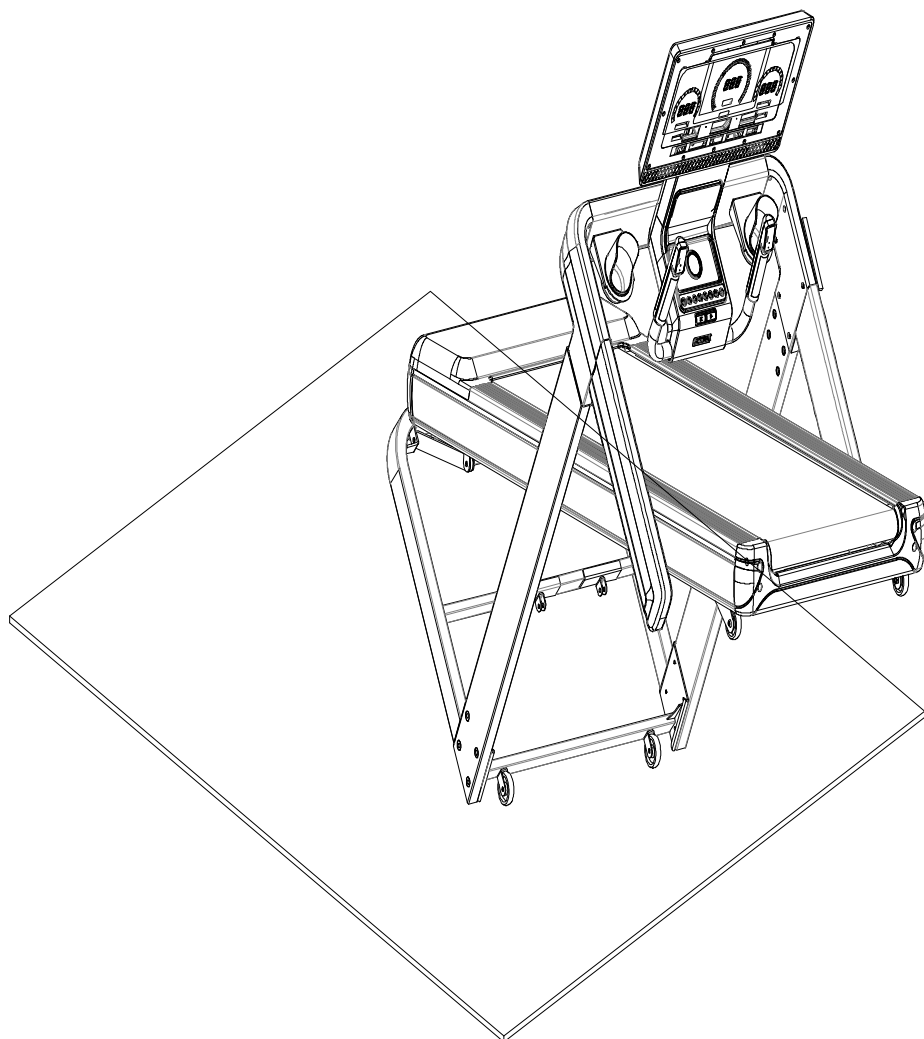

1、Folding

Cut off the power when plan to fold the treadmill.

2、Unfolding

1. When unfolding the treadmill, you should choose one place where around 1m away from the power socket, and the ground is flat without any barriers.

3、moving

First you need be sure following things before moving:

- 1: the power is off;
- 2: the plug has been pulled out from the socket;
- 3: the treadmill has been folded;

Then you can catch the end of treadmill with one hand, and catch the handlebar at the same side with another hand, tilt 30~40° up to chest to move the treadmill slowly.

TREADMILL MAINTENANCE

Proper maintenance is very important to ensure a faultless and operational condition of the treadmill. Improper maintenance can cause damage to the treadmill or shorten the life of the product. All parts of the treadmill shall be checked and tightened regularly. Worn out parts must be replaced immediately.

Lubrication

After the running belt has been used for a period of time, it must be lubricated with the configured methyl silicone oil. Suggestion:

- | | |
|--|---------------------------------|
| Using time less than 3 hours every week | lubrication once every 5 months |
| Using time equal to 4-7 hours every week | lubrication once every 2 months |
| Using time more than 7 hours every week | lubrication once every month |

No excessive lubrication. Note: the important factor of increase the lifetime for treadmill is proper lubrication.

How to check if the running belt need lubrication: You can lift up the running belt and touch the middle of back of running belt. If your hands are stained with silicone oil (something damp), it means no need more silicone oil .

How to lubricate the belt:

Step 1: Stop the running belt, and fold the treadmill.

Step 2: Lift up the running belt from the back of main frame and put the silicone oil bottle as far as to middle of the belt, spray silicone oil starting from the middle of running belt then to two sides.

Step 3: Unfold the treadmill and run the treadmill at a speed of 1km/h to apply silicone evenly, tread lightly on the running belt from left to right for several minutes to let belt absorb the silicon spray.

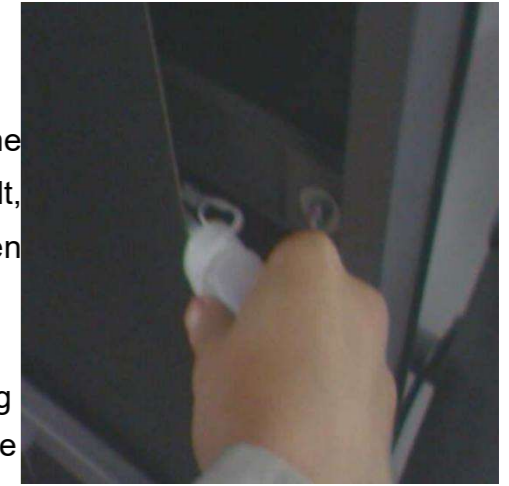

Cleaning

Regular cleaning of the running belt ensures a long product life.

Warning: The treadmill shall be turned off to avoid electrical shocks. The power cord shall be pulled out of the socket, before starting the cleaning or maintenance.

- After training: Wipe the console and other surfaces with a clean soft and damp cloth to remove sweat residues.
Caution: Do not use any abrasives or solvents. To avoid damage to the console, keep any liquids away. Do not expose the console to direct sunlight.
- Weekly: To make the cleaning easier it is recommended to use a mat for the treadmill. Shoes can leave dirt on the running belt that can fall beneath the treadmill. Clean the mat under the treadmill once a week.
Storage: Store your treadmill in a clean and dry environment. Ensure power off and the power cord is unplugged from the electric socket.

Running belt tension adjustment

All running belts are properly set at the factory and after assembly. However, after a period of use, loose belt may occur, and the user might feel pause or slipping belt. Adjust the running belt tension by turning left and right adjusting bolt 1/4 turn clockwise with Allen Wrench until proper tension.

Proper running belt tension is important, if loose belt, the running belt and the roller will slip in turn. But too tight, it increase the load of the motor and damage the motor, running belt and roller, etc.

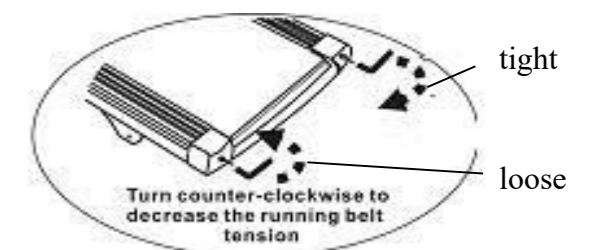
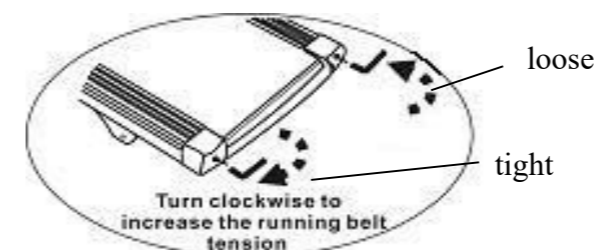

Running belt deviation adjustment:

All running belts are properly set at the factory and after assembly. However, after a period of use, belt deviation might occur. The reasons might be as follows.

- ① The treadmill is not placed in level surface.
- ② The user don't run in the center of the running belt.
- ③ The user don't apply even force on both feet.

When this deviation occurs, the running belt can run several minutes without load, to return to normal. But if not, turning left or right adjusting bolt 1/4 turn clockwise with Allen Wrench until centered.

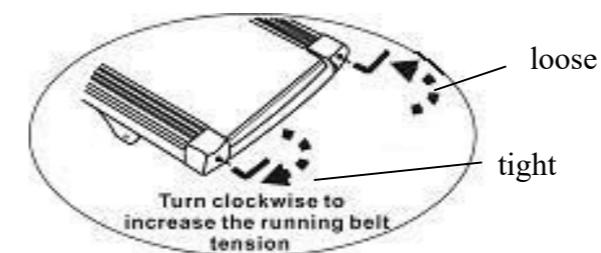

for left deviation,
Adjust the left bolt clockwise or the right bolt anti-clockwise.

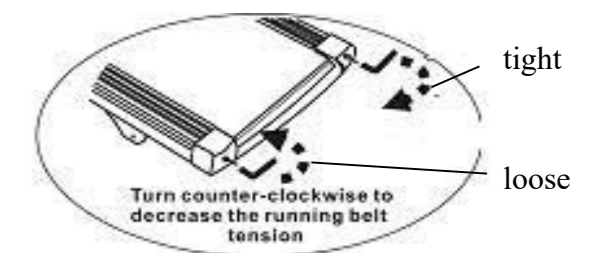

For right deviation.
adjust the right bolt clockwise or the left bolt anti-clockwise.

KEY POINT:

- Clockwise means tighten.
- Anti-clockwise means loosen.
- Running belt will shift to the loose side.

① If the running belt shifts to the left, that means the left side is too loose.
Adjust the left bolt clockwise to make the left tighter.
Or adjust the right screw anti-clockwise to make the right looser.

② If the running belt shifts to the right, that means the right side is too loose.
Adjust the right bolt clockwise to make the right tighter
Or adjust the left screw anti-clockwise to make the left looser.

Attention:

-You need to start the treadmill (let the belt run) at a low speed before you adjust the running belt.

-When you adjust the bolt, don't rotate it too much.

-After each adjustment you need to look for the changes in the running belt.

Running belt deviation is not covered by the warranty, and is mainly maintained by users according to the instructions. Running deviation can seriously damage the running belt. It must be found and corrected in time.

Customer Service

Echelon Fitness Multimedia

605 Chestnut St. | Suite 700 | Chattanooga TN 37450

Questions or Concerns

Our members are our priority! If you require assistance or have concerns, please contact our customer service team.

(423) 455-8989

cs@echelonfit.com

Submit a Request:

