



MEASUREMENT REPORT

FCC PART 27(H)

FCC ID: 2AWAS-910-00085
Application: Mavenir Systems, Inc.

Application Type: Certification
Product: B12 4T4R 160W Radio Unit
Model No.: MR44EA
Trademark: 
FCC Rule Part(s): Part 27 Subpart H
Test Procedure(s): ANSI C63.26-2015
Test Date: August 20 ~ September 07, 2021

Reviewed By:

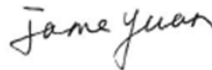

Jame Yuan

Approved By:

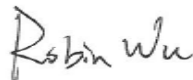

Robin Wu



The test results relate only to the samples tested.

This equipment has been shown to be capable of compliance with the applicable technical standards as indicated in the measurement report and was tested in accordance with the measurement procedures specified in ANSI C63.26-2015. Test results reported herein relate only to the item(s) tested.

The test report shall not be reproduced except in full without the written approval of MRT Technology (Suzhou) Co., Ltd.

Revision History

Report No.	Version	Description	Issue Date	Note
2108RSU044-U1	Rev. 01	Initial Report	09-10-2021	Invalid
2108RSU044-U1	Rev. 02	Update some information	09-17-2021	Valid

CONTENTS

Description	Page
1. GENERAL INFORMATION	5
1.1. Applicant.....	5
1.2. Manufacturer	5
1.3. Testing Facility	5
1.4. Product Information	6
1.5. Emission Designator.....	7
1.6. Test Mode and Channel Detail.....	8
1.7. EMI Suppression Device(s)/Modifications	8
1.8. Applicable Standards.....	8
1.9. Test Environment Condition.....	8
2. TEST EQUIPMENT CALIBRATION DATE	9
3. MEASUREMENT UNCERTAINTY	11
4. TEST RESULT	12
4.1. Summary	12
4.2. Equivalent Radiated Power Measurement	13
4.2.1. Test Limit	13
4.2.2. Test Procedures Used	13
4.2.3. Test Setting	13
4.2.4. Test Setup	14
4.2.5. Test Result	15
4.3. Frequency Stability Measurement.....	22
4.3.1. Test Limit	22
4.3.2. Test Procedures Used	22
4.3.3. Test Setting	22
4.3.4. Test Setup	23
6.3.5. Test Result.....	24
4.4. Emission Bandwidth	25
4.4.1. Test Limit	25
4.4.2. Test Procedure	25
4.4.3. Test Setting	25
4.4.4. Test Setup	26
6.4.5. Test Result.....	27
4.5. Band Edge Measurement	44
4.5.1. Test Limit	44
4.5.2. Test Procedure Used.....	44
4.5.3. Test Setting	44
4.5.4. Test Setup	45

4.5.5. Test Result	46
4.6. Conducted Spurious Emissions	59
4.6.1. Test Limit	59
4.6.2. Test Procedure Used	59
4.6.3. Test Setting	59
4.6.4. Test Setup	60
6.7.5. Test Result.....	61
4.7. Radiated Spurious Emissions Measurements.....	66
4.7.1. Test Limit	66
4.7.2. Test Procedure Used	66
4.7.3. Test Setting	66
4.7.4. Test Setup	67
4.7.5. Test Result	68
5. CONCLUSION.....	69
Appendix A - Test Setup Photograph	70
Appendix B - EUT Photograph	71

1. GENERAL INFORMATION

1.1. Applicant

Mavenir Systems, Inc.
1700 International Pkwy, Richardson, TX 75081, USA

1.2. Manufacturer

JABIL CIRCUIT (SHANGHAI) LTD
600, TIAN LIN ROAD, SHANGHAI, 200233, P.R. CHINA

1.3. Testing Facility

<input checked="" type="checkbox"/>	<p>Test Site – MRT Suzhou Laboratory</p> <p>Laboratory Location (Suzhou - Wuzhong) D8 Building, No.2 Tian’edang Rd., Wuzhong Economic Development Zone, Suzhou, China</p> <p>Laboratory Location (Suzhou - SIP) 4b Building, Liando U Valley, No.200 Xingpu Rd., Shengpu Town, Suzhou Industrial Park, China</p> <p>Laboratory Accreditations</p> <p>A2LA: 3628.01 CNAS: L10551 FCC: CN1166 ISED: CN0001</p> <p>VCCI: <input type="checkbox"/>R-20025 <input type="checkbox"/>G-20034 <input type="checkbox"/>C-20020 <input type="checkbox"/>T-20020 <input type="checkbox"/>R-20141 <input type="checkbox"/>G-20134 <input type="checkbox"/>C-20103 <input type="checkbox"/>T-20104</p>
<input type="checkbox"/>	<p>Test Site – MRT Shenzhen Laboratory</p> <p>Laboratory Location (Shenzhen) 1G, Building A, Junxiangda Building, Zhongshanyuan Road West, Nanshan District, Shenzhen, China</p> <p>Laboratory Accreditations</p> <p>A2LA: 3628.02 CNAS: L10551 FCC: CN1284 ISED: CN0105</p>
<input type="checkbox"/>	<p>Test Site – MRT Taiwan Laboratory</p> <p>Laboratory Location (Taiwan) No. 38, Fuxing 2nd Rd., Guishan Dist., Taoyuan City 333, Taiwan (R.O.C.)</p> <p>Laboratory Accreditations</p> <p>TAF: L3261-190725 FCC: 291082, TW3261 ISED: TW3261</p>

1.4. Product Information

Product Name	B12 4T4R 160W Radio Unit
Model No.	MR44EA
Test Device Serial No.	JW2126CTN-AA005
Hardware Version	2.2
Software Version	MD4.5
Voltage Range	-48 VDC
LTE Operating Band (s)	FDD Band 12
Modulation Type	QPSK, 16QAM, 64QAM, 256QAM
T _x Frequency Range	Band 12: 729 ~ 745 MHz
R _x Frequency Range	Band 12: 699 ~ 715 MHz
Max ERP Power Density	5MHz: 64.85 dBm/MHz; 10MHz: 64.85 dBm/MHz; 15MHz: 64.76 dBm/MHz; 5 + 5MHz: 64.83 dBm/MHz; 5 + 10MHz: 64.85 dBm/MHz; 5 + GAP6 + 5MHz: 64.81 dBm/MHz 5 + GAP1 + 10MHz: 64.80 dBm/MHz
Max Antenna Gain	15dBi

Note1: GAP1 means the interval between two carriers is 1MHz, GAP6 means the interval between two carriers is 6MHz.

Note2: The information of EUT was provided by the manufacturer, and the accuracy of the information shall be the responsibility of the manufacturer.

1.5. Emission Designator

B12		QPSK		16QAM	
BW (MHz)	Feq. (MHz)	Designator	Max Conducted Power (W)	Designator	Max Conducted Power (W)
5	731.5 ~ 742.5	4M48G7D	155.60	4M47W7D	158.49
10	734.0 ~ 740.0	8M95G7D	158.49	8M95W7D	155.60
15	736.5 ~ 737.5	13M4G7D	154.53	13M4W7D	155.24
5 + 5	731.5 ~ 742.5	9M43G7D	155.96	9M94W7D	154.88
5 + 10	731.5 ~ 740.0	14M1G7D	155.24	14M2W7D	155.24
5 + GAP6 + 5	731.5+742.5	8M95G7D	157.04	8M95W7D	153.11
5 + GAP1 + 10	731.5+740.0	13M4G7D	156.68	13M4W7D	151.71
B12		64QAM		256QAM	
BW (MHz)	Feq. (MHz)	Designator	Max Conducted Power (W)	Designator	Max Conducted Power (W)
5	731.5 ~ 742.5	4M48W7D	158.49	4M48W7D	158.49
10	734.0 ~ 740.0	8M95W7D	153.46	8M94W7D	155.60
15	736.5 ~ 737.5	13M4W7D	153.82	13M4W7D	153.82
5 + 5	731.5 ~ 742.5	9M45W7D	157.76	9M44W7D	153.46
5 + 10	731.5 ~ 740.0	14M2W7D	155.24	14M2W7D	158.49
5 + GAP6 + 5	731.5+742.5	8M96W7D	154.88	8M95W7D	155.24
5 + GAP1 + 10	731.5+740.0	13M4W7D	153.82	13M4W7D	156.31

1.6. Test Mode and Channel Detail

Spot Check Test Item	Channel Bandwidth	Modulation
Equivalent Radiated Power	5 MHz, 10 MHz, 15 MHz	QPSK, 16QAM, 64QAM, 256QAM
Emission Bandwidth	5 MHz + 5MHz 5MHz + GAP6 + 5MHz 5 MHz + 10 MHz 5 MHz + GAP1 + 10 MHz	
Peak to Average Ratio	5 MHz, 10 MHz, 15 MHz	
Conducted Spurious Emissions	5 MHz + 5MHz 5MHz + GAP6 + 5MHz 5 MHz + 10 MHz 5 MHz + GAP1 + 10 MHz	
Band Edge Measurements	5 MHz + 10 MHz 5 MHz + GAP1 + 10 MHz	QPSK
Frequency Stability	15MHz	
Radiated Spurious Emissions	5 MHz	

Note: For radiated spurious emissions, only the minimum bandwidth of a single carrier was assessed.

1.7. EMI Suppression Device(s)/Modifications

No EMI suppression device(s) were added and/or no modifications were made during testing.

1.8. Applicable Standards

According to the specifications of the manufacturer, the EUT must comply with the requirements of the following standards:

- ANSI C63.26 - 2015
- FCC KDB 971168 D01v03r01
- FCC Part 27 Subpart H

1.9. Test Environment Condition

Ambient Temperature	15 ~ 35°C
Relative Humidity	20 ~ 75%RH

2. TEST EQUIPMENT CALIBRATION DATE

Transmitter Spurious Emissions and Receiver Spurious Emissions (WZ-AC1)

Instrument	Manufacturer	Type No.	Asset No.	Cali. Interval	Cal. Due Date
EMI Test Receiver	R&S	ESR7	MRTSUE06001	1 year	2022/01/04
EXA Signal Analyzer	Keysight	N9010B	MRTSUE06558	1 year	2022/07/21
Wideband Radio Communication Tester	R&S	CMW 500	MRTSUE06243	1 year	2021/11/07
Loop Antenna	Schwarzbeck	FMZB 1519	MRTSUE06025	1 year	2021/11/08
Bilog Period Antenna	Schwarzbeck	VULB 9168	MRTSUE06172	1 year	2022/08/05
Horn Antenna	Schwarzbeck	BBHA 9120D	MRTSUE06023	1 year	2021/09/27
Microwave System Amplifier	Agilent	83017A	MRTSUE06076	1 year	2021/11/14
Thermal Hygrometer	testo	608-H1	MRTSUE06403	1 year	2022/07/21
Anechoic Chamber	TDK	Chamber-AC1	MRTSUE06212	1 year	2022/04/29

Transmitter Spurious Emissions and Receiver Spurious Emissions (WZ-AC2)

Instrument	Manufacturer	Type No.	Asset No.	Cali. Interval	Cal. Due Date
MXE EMI Receiver	Keysight	N9038A	MRTSUE06125	1 year	2022/06/22
Wideband Radio Communication Tester	R&S	CMW 500	MRTSUE06243	1 year	2021/11/07
Loop Antenna	Schwarzbeck	FMZB 1519	MRTSUE06025	1 year	2021/11/08
Bilog Period Antenna	Schwarzbeck	VULB 9162	MRTSUE06022	1 year	2022/05/24
Broad-Band Horn Antenna	Schwarzbeck	BBHA 9120D	MRTSUE06171	1 year	2021/10/25
Broadband Coaxial Pre-amplifier	Schwarzbeck	BBV 9718	MRTSUE06176	1 year	2021/11/14
Thermal Hygrometer	Minggao	ETH529	MRTSUE06170	1 year	2021/12/08
Anechoic Chamber	RIKEN	Chamber-AC2	MRTSUE06213	1 year	2022/04/29

Instrument	Manufacturer	Type No.	Asset No.	Cali. Interval	Cali. Due Date
Tunable Bandreject Filter	Wainwright Instruments GmbH	WTRCTV5-780-980-20-70-60SSK	MRTSUE06133	1 year	2022/06/22
Tunable Bandreject Filter	Wainwright Instruments GmbH	WTRCT10-1710-2130-20-40-50SSK	MRTSUE06134	1 year	2022/07/21
High-Pass Filter	Wainwright Instruments GmbH	WHKX1.1/15G-10SS	MRTSUE06066	1 year	2022/03/25
High pass Filter	Wainwright Instruments GmbH	WHKX10-2501-3050-18000-80SS	MRTSUE06151	1 year	2022/07/21
Temperature/Humidity Meter	Minggao	ETH529	MRTSUE06170	1 year	2021/12/13

Conducted Measurement (WZ-SR6, WZ-TR3)

Instrument	Manufacturer	Type No.	Asset No.	Cali. Interval	Cali. Due Date
Wideband Radio Communication Tester	R&S	CMW 500	MRTSUE06243	1 year	2021/11/07
Spectrum Analyzer	Agilent	N9020A	MRTSUE06106	1 year	2022/04/13
EXA Signal Analyzer	Keysight	N9010B	MRTSUE06452	1 year	2022/07/07
Power Meter	Agilent	U2021XA	MRTSUE06030	1 year	2021/11/18
ESG Vector Signal Generator	Agilent	E4438C	MRTSUE06026	1 year	2021/11/07
MXG Vector Signal Generator	Keysight	N5182B	MRTSUE06451	1 year	2022/06/24
EXA Signal Analyzer	Keysight	N9010A	MRTSUE06195	1 year	2022/04/13
Programmable Temperature & Humidity Chamber	BAOYT	BYH-1500L	MRTSUE06051	1 year	2021/11/07

Software	Version	Function
EMI Software	V3	EMI Test Software

3. MEASUREMENT UNCERTAINTY

Where relevant, the following test uncertainty levels have been estimated for tests performed on the EUT as specified in CISPR 16-4-2. This uncertainty represents an expanded uncertainty expressed at approximately the 95% confidence level using a coverage factor of $k = 2$.

Radiated Disturbance
Measurement Uncertainty for a Level of Confidence of 95% ($U=2Uc(y)$): Horizontal: 9kHz~300MHz: 5.04dB 300MHz~1GHz: 4.95dB 1GHz~40GHz: 6.40dB Vertical: 9kHz~300MHz: 5.24dB 300MHz~1GHz: 6.03dB 1GHz~40GHz: 6.40dB
Spurious Emissions, Conducted
Measuring Uncertainty for a Level of Confidence of 95% ($U=2Uc(y)$): 0.78dB
Output Power
Measuring Uncertainty for a Level of Confidence of 95% ($U=2Uc(y)$): 1.13dB
Power Spectrum Density
Measuring Uncertainty for a Level of Confidence of 95% ($U=2Uc(y)$): 1.15dB
Occupied Bandwidth
Measuring Uncertainty for a Level of Confidence of 95% ($U=2Uc(y)$): 0.28%

4. TEST RESULT

4.1. Summary

FCC Section(s)	Test Description	Test Condition	Test Result	Reference
2.1046; 27.50(c)	Equivalent Radiated Power	Conducted	Pass	Section 4.2
2.1055; 27.54	Frequency Stability		Pass	Section 4.3
2.1049	Emission Bandwidth		Pass	Section 4.4
27.53(g)	Band Edge Measurements		Pass	Section 4.5
2.1051; 27.53(g)	Conducted Spurious Emissions		Pass	Section 4.6
2.1053; 27.53(g)	Radiated Spurious Emissions	Radiated	Pass	Section 4.7

Notes:

- 1) The analyzer plots shown in this section were all taken with a correction table loaded into the analyzer. The correction table was used to account for the losses of the cables and attenuators used as part of the system to connect the EUT to the analyzer at all frequencies of interest.
- 2) The Channel Band-edge, Radiated Spurious Emission were presented the worst test data of modulation & antenna port in the test report.
- 3) During the radiated spurious emission test, all the connectors under test are terminated.

4.2. Equivalent Radiated Power Measurement

4.2.1. Test Limit

According to the specific rule Part 27.50(c)(3), Fixed and base stations transmitting a signal with an emission bandwidth greater than 1 MHz must not exceed an ERP of 1000 watts/MHz.

4.2.2. Test Procedures Used

KDB 971168 D01v03r01 - Section 5.2.4 & 5.4 & 5.6

ANSI C63.26-2015 - Section 5.2.4.2 & 5.2.4.5 & 5.2.5.5

4.2.3. Test Setting

Average Power Measurement

Average power measurements were performed only when the EUT was transmitting at its maximum power control level using a broadband power meter with a pulse sensor. The power meter implemented triggering and gating capabilities which were set up such that power measurements were recorded only during the ON time of the transmitter.

Average Power Spectral Density Measurement

1. Span to $2 \times$ to $3 \times$ the OBW
2. RBW $\geq 1\%$ to 5% of the OBW
3. VBW $\geq 3 \times$ RBW
4. Sweep time $\geq 10 \times$ (number of points in sweep) \times (transmission symbol period)
5. Detector = power averaging (rms)
6. Set sweep trigger to "free run"
7. If the EUT can be configured to transmit continuously, then set the trigger to free run
8. Trace average at least 100 traces in power averaging (rms) mode if sweep is set to auto-couple.
9. The trace was allowed to stabilize
10. RBW set to the reference bandwidth specified by the applicable regulatory requirement, and by using the marker function to identify the maximum PSD.

Note: The relevant equation for determining the maximum ERP or EIRP from the measured RF output power is given in Equation (1) as follows:

$$\text{ERP or EIRP} = P_{\text{Meas}} + G_T$$

Where

ERP or EIRP effective radiated power or equivalent isotropically radiated power, respectively (expressed in the same units as P_{Meas} , e.g., dBm or dBW)

P_{Meas} measured transmitter output power or PSD, in dBm or dBW

G_T gain of the transmitting antenna, in dBd (ERP) or dBi (EIRP)

$$\text{ERP} = \text{EIRP} - 2.15$$

4.2.4. Test Setup

Average Power Spectral Density Measurement

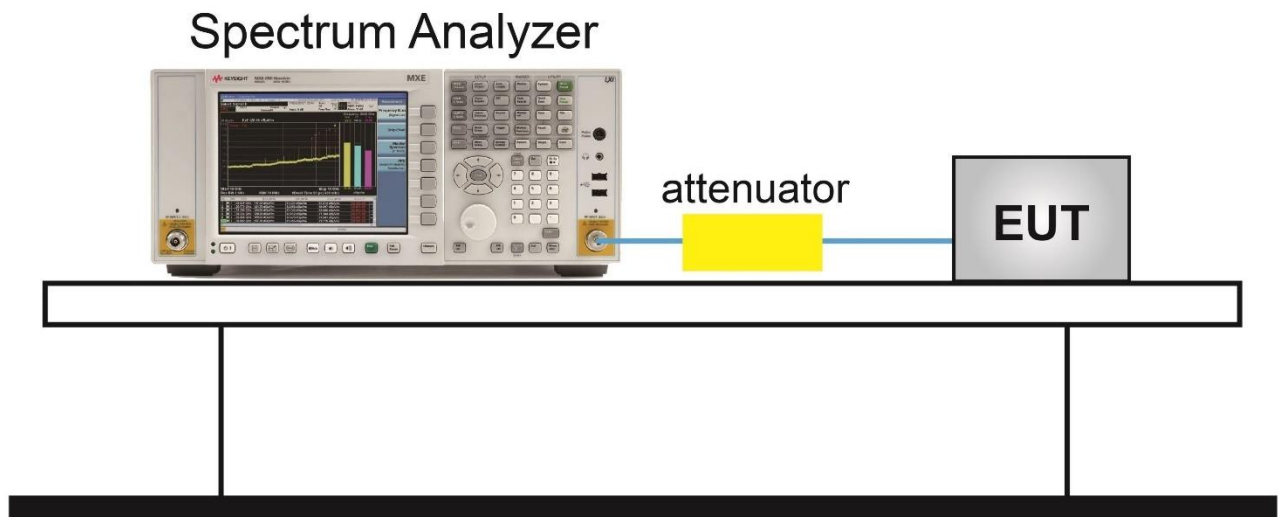

Conducted Measurement of Output Power

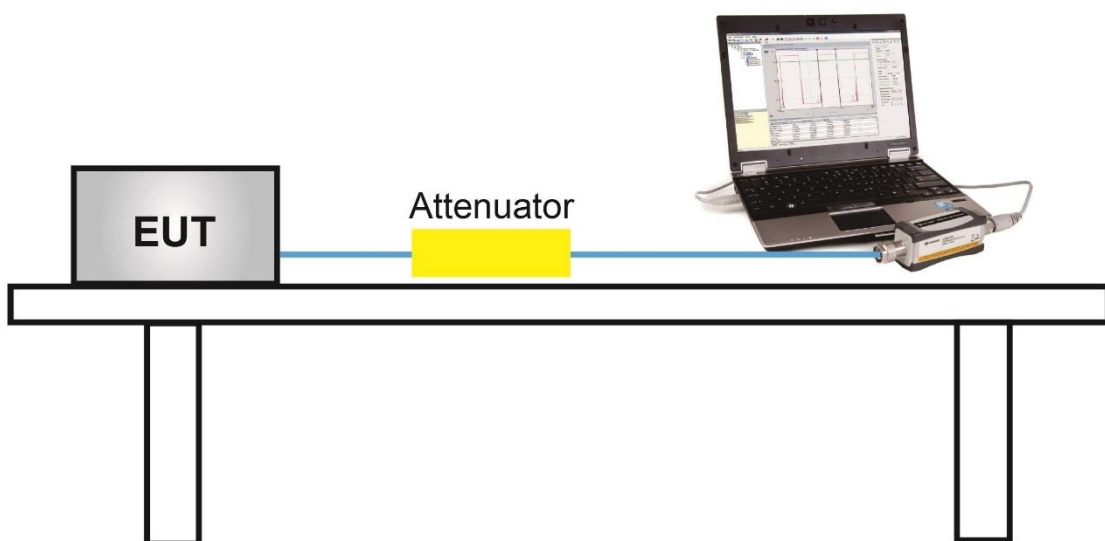

4.2.5. Test Result

Product	B12 4T4R 160W Radio Unit	Test Engineer	Larry Yan
Test Site	WZ-SR6	Test Date	2021/08/20 ~ 2021/09/02
Test Configuration	LTE Band 12		

Frequency (MHz)	Channel Bandwidth (MHz)	Power Density (dBm/MHz)				Total Power Density (dBm/MHz)	ERP Density (dBm/MHz)	Limit (dBm/MHz)
		Ant 1	Ant 2	Ant 3	Ant 4			
QPSK								
731.5	5	39.44	39.31	39.22	39.30	45.34	58.19	< 60
737.0	5	39.51	39.42	39.23	39.35	45.40	58.25	< 60
742.5	5	39.36	39.41	39.18	39.24	45.32	58.17	< 60
734.0	10	36.58	36.53	36.35	36.54	42.52	55.37	< 60
737.0	10	36.38	36.55	36.20	36.27	42.37	55.22	< 60
740.0	10	36.41	36.56	36.27	36.35	42.42	55.27	< 60
736.5	15	34.42	34.58	34.09	34.18	40.34	53.19	< 60
737.0	15	34.38	34.22	34.10	34.13	40.23	53.08	< 60
737.5	15	35.28	34.46	34.07	34.24	40.56	53.41	< 60
731.5+736.5	5 + 5	36.42	36.41	36.21	36.45	42.39	55.24	< 60
734.5+739.5	5 + 5	36.56	36.51	36.33	36.42	42.48	55.33	< 60
737.5 +742.5	5 + 5	36.54	36.53	36.35	36.34	42.46	55.31	< 60
731.5+742.5	5 + GAP6 + 5	36.60	36.37	36.42	36.13	42.40	55.25	< 60
731.5+739.0	5 + 10	36.19	36.26	36.07	36.48	42.27	55.12	< 60
732.5+739.5	5 + 10	36.50	36.46	36.08	36.28	42.35	55.20	< 60
732.5+740.0	5 + 10	36.27	36.42	36.07	36.41	42.32	55.17	< 60
731.5+740.0	5 + GAP1 + 10	36.53	36.30	35.85	36.35	42.29	55.14	< 60

Note 1: Total Power Density (dBm/MHz) = $10 \cdot \log \{ 10^{[ANT 1 \text{ Power Density} / 10]} + 10^{[ANT 2 \text{ Power Density} / 10]} + 10^{[ANT 3 \text{ Power Density} / 10]} + 10^{[ANT 4 \text{ Power Density} / 10]} \}$ (dBm/MHz).

Note 2: ERP Density (dBm/MHz) = Total Power Density (dBm/MHz) + Antenna Gain (dBi) - 2.15dB.

Frequency (MHz)	Channel Bandwidth (MHz)	Power Density (dBm/MHz)				Total Power Density (dBm/MHz)	ERP Density (dBm/MHz)	Limit (dBm/MHz)
		Ant 1	Ant 2	Ant 3	Ant 4			
16QAM								
731.5	5	39.88	39.84	39.65	39.70	45.79	58.64	< 60
737.0	5	39.90	39.87	39.52	39.29	45.67	58.52	< 60
742.5	5	39.86	39.80	39.67	39.83	45.81	58.66	< 60
734.0	10	36.79	36.79	35.84	36.07	42.41	55.26	< 60
737.0	10	36.86	36.70	36.57	36.69	42.73	55.58	< 60
740.0	10	36.95	36.45	36.62	36.64	42.69	55.54	< 60
736.5	15	35.22	34.87	35.01	34.64	40.96	53.81	< 60
737.0	15	34.91	34.38	34.86	35.06	40.83	53.68	< 60
737.5	15	34.53	35.25	34.96	34.99	40.96	53.81	< 60
731.5+736.5	5 + 5	36.87	36.89	36.58	36.80	42.81	55.66	< 60
734.5+739.5	5 + 5	36.67	36.96	36.53	36.80	42.76	55.61	< 60
737.5 +742.5	5 + 5	36.85	36.65	36.60	36.76	42.74	55.59	< 60
731.5+742.5	5 + GAP6 + 5	36.71	36.52	36.38	36.68	42.60	55.45	< 60
731.5+739.0	5 + 10	36.86	36.55	36.27	36.49	42.57	55.42	< 60
732.5+739.5	5 + 10	36.80	36.74	36.46	36.57	42.67	55.52	< 60
732.5+740.0	5 + 10	36.95	36.82	36.63	36.60	42.77	55.62	< 60
731.5+740.0	5 + GAP1 + 10	36.88	36.23	36.51	36.44	42.54	55.39	< 60

Note 1: Total Power Density (dBm/MHz) = $10 \cdot \log \{ 10^{[ANT 1 \text{ Power Density} / 10]} + 10^{[ANT 2 \text{ Power Density} / 10]} + 10^{[ANT 3 \text{ Power Density} / 10]} + 10^{[ANT 4 \text{ Power Density} / 10]} \}$ (dBm/MHz).

Note 2: ERP Density (dBm/MHz) = Total Power Density (dBm/MHz) + Antenna Gain (dBi) - 2.15dB.

Frequency (MHz)	Channel Bandwidth (MHz)	Power Density (dBm/MHz)				Total Power Density (dBm/MHz)	ERP Density (dBm/MHz)	Limit (dBm/MHz)
		Ant 1	Ant 2	Ant 3	Ant 4			
256QAM								
731.5	5	39.45	39.42	39.30	39.34	45.40	58.25	< 60
737.0	5	39.44	39.45	39.22	39.44	45.41	58.26	< 60
742.5	5	39.41	39.34	39.20	39.26	45.32	58.17	< 60
734.0	10	36.49	36.31	36.23	36.33	42.36	55.21	< 60
737.0	10	36.43	36.27	36.13	36.26	42.29	55.14	< 60
740.0	10	36.55	36.39	36.22	36.44	42.42	55.27	< 60
736.5	15	34.41	34.44	34.16	34.12	40.31	53.16	< 60
737.0	15	34.36	34.41	34.17	34.07	40.28	53.13	< 60
737.5	15	34.45	34.41	34.15	34.28	40.34	53.19	< 60
731.5+736.5	5 + 5	36.42	36.43	36.15	36.32	42.35	55.20	< 60
734.5+739.5	5 + 5	36.52	36.29	36.21	36.21	42.33	55.18	< 60
737.5 +742.5	5 + 5	36.25	36.32	36.33	36.26	42.31	55.16	< 60
731.5+742.5	5 + GAP6 + 5	36.54	36.14	36.15	36.13	42.26	55.11	< 60
731.5+739.0	5 + 10	36.97	37.30	36.83	36.92	43.03	55.88	< 60
732.5+739.5	5 + 10	36.31	36.40	36.07	36.33	42.30	55.15	< 60
732.5+740.0	5 + 10	36.36	36.34	36.12	35.96	42.22	55.07	< 60
731.5+740.0	5 + GAP1 + 10	36.11	36.19	35.92	35.98	42.07	54.92	< 60

Note 1: Total Power Density (dBm/MHz) = $10 \cdot \log \{ 10^{[ANT 1 \text{ Power Density} / 10]} + 10^{[ANT 2 \text{ Power Density} / 10]} + 10^{[ANT 3 \text{ Power Density} / 10]} + 10^{[ANT 4 \text{ Power Density} / 10]} \}$ (dBm/MHz).

Note 2: ERP Density (dBm/MHz) = Total Power Density (dBm/MHz) + Antenna Gain (dBi) - 2.15dB.

Product	B12 4T4R 160W Radio Unit	Test Engineer	Larry Yan
Test Site	WZ-SR6	Test Date	2021/08/20 ~ 2021/09/02
Test Configuration	LTE Band 12		

Test Result of Average Output Power (Reporting Only)

Frequency (MHz)	Channel Bandwidth (MHz)	Power (dBm)				Total power (dBm)	ERP (dBm)
		Ant 1	Ant 2	Ant 3	Ant 4		
QPSK							
731.5	5	45.92	45.99	45.75	45.87	51.90	64.75
737.0	5	45.99	45.97	45.78	45.86	51.92	64.77
742.5	5	45.96	45.93	45.80	45.89	51.92	64.77
734.0	10	46.04	46.00	45.91	45.96	52.00	64.85
737.0	10	46.06	45.98	45.89	45.96	51.99	64.84
740.0	10	45.99	46.01	45.87	45.98	51.98	64.83
736.5	15	45.93	45.89	45.86	45.79	51.89	64.74
737.0	15	45.92	45.89	45.82	45.83	51.89	64.74
737.5	15	45.93	45.94	45.83	45.78	51.89	64.74
731.5+736.5	5 + 5	46.05	45.79	45.86	45.92	51.93	64.78
734.5+739.5	5 + 5	45.97	45.86	45.70	45.89	51.88	64.73
737.5 +742.5	5 + 5	45.96	45.95	45.81	45.76	51.89	64.74
731.5+742.5	5 + GAP6 + 5	45.99	46.02	45.89	45.84	51.96	64.81
731.5+739.0	5 + 10	45.97	45.80	45.83	45.84	51.88	64.73
732.5+739.5	5 + 10	45.99	45.84	45.84	45.89	51.91	64.76
732.5+740.0	5 + 10	45.91	45.89	45.77	45.94	51.90	64.75
731.5+740 .0	5 + GAP1 + 10	46.03	45.92	45.90	45.86	51.95	64.80

Note: Total Power (dBm) = $10 \cdot \log \{ 10^{[ANT 1 \text{ Power (dBm) / 10}]} + 10^{[ANT 2 \text{ Power (dBm) / 10}]} + 10^{[ANT 3 \text{ Power (dBm) / 10}]} + 10^{[ANT 4 \text{ Power (dBm) / 10}]} \}$ (dBm).

Frequency (MHz)	Channel Bandwidth (MHz)	Power (dBm)				Total power (dBm)	ERP (dBm)
		Ant 1	Ant 2	Ant 3	Ant 4		
16QAM							
731.5	5	45.99	46.01	45.80	45.83	51.93	64.78
737.0	5	46.02	45.98	45.89	45.96	51.98	64.83
742.5	5	46.03	45.91	45.97	45.99	52.00	64.85
734.0	10	45.98	45.93	45.78	45.87	51.91	64.76
737.0	10	45.97	45.97	45.79	45.88	51.92	64.77
740.0	10	45.98	45.83	45.78	45.87	51.89	64.74
736.5	15	45.92	45.88	45.75	45.81	51.86	64.71
737.0	15	45.91	46.01	45.86	45.77	51.91	64.76
737.5	15	45.93	45.88	45.79	45.79	51.87	64.72
731.5+736.5	5 + 5	45.95	45.83	45.84	45.89	51.90	64.75
734.5+739.5	5 + 5	45.93	45.89	45.82	45.75	51.87	64.72
737.5 +742.5	5 + 5	45.89	45.80	45.75	45.82	51.84	64.69
731.5+742.5	5 + GAP6 + 5	45.99	45.73	45.78	45.83	51.85	64.70
731.5+739.0	5 + 10	45.99	45.78	45.86	45.82	51.88	64.73
732.5+739.5	5 + 10	45.87	45.71	45.81	45.79	51.82	64.67
732.5+740.0	5 + 10	45.98	45.80	45.91	45.86	51.91	64.76
731.5+740 .0	5 + GAP1 + 10	45.89	45.87	45.66	45.75	51.81	64.66

Note: Total Power (dBm) = $10 \cdot \log \{ 10^{[ANT 1 \text{ Power (dBm) / 10}]} + 10^{[ANT 2 \text{ Power (dBm) / 10}]} + 10^{[ANT 3 \text{ Power (dBm) / 10}]} + 10^{[ANT 4 \text{ Power (dBm) / 10}]} \}$ (dBm).

Frequency (MHz)	Channel Bandwidth (MHz)	Power (dBm)				Total power (dBm)	ERP (dBm)
		Ant 1	Ant 2	Ant 3	Ant 4		
64QAM							
731.5	5	45.89	46.01	45.79	45.86	51.91	64.76
737.0	5	46.01	46.04	45.84	46.00	51.99	64.84
742.5	5	46.03	46.02	45.92	45.95	52.00	64.85
734.0	10	45.95	45.70	45.69	45.77	51.80	64.65
737.0	10	45.89	45.78	45.80	45.88	51.86	64.71
740.0	10	45.87	45.86	45.73	45.77	51.83	64.68
736.5	15	45.92	45.88	45.75	45.81	51.84	64.69
737.0	15	45.91	46.01	45.86	45.77	51.86	64.71
737.5	15	45.93	45.88	45.79	45.79	51.87	64.72
731.5+736.5	5 + 5	46.01	46.01	45.91	45.89	51.98	64.83
734.5+739.5	5 + 5	45.83	45.77	45.67	45.76	51.78	64.63
737.5 +742.5	5 + 5	45.78	45.87	45.69	45.81	51.81	64.66
731.5+742.5	5 + GAP6 + 5	46.04	45.88	45.79	45.81	51.90	64.75
731.5+739.0	5 + 10	46.01	45.81	45.81	45.92	51.91	64.76
732.5+739.5	5 + 10	45.98	45.76	45.79	45.80	51.85	64.70
732.5+740.0	5 + 10	45.96	45.86	45.86	45.83	51.90	64.75
731.5+740.0	5 + GAP1 + 10	45.89	45.91	45.81	45.80	51.87	64.72

Note: Total Power (dBm) = $10 \cdot \log \{ 10^{[ANT 1 \text{ Power (dBm) / 10}] + 10^{[ANT 2 \text{ Power (dBm) / 10}] + 10^{[ANT 3 \text{ Power (dBm) / 10}] + 10^{[ANT 4 \text{ Power (dBm) / 10}]} \}$ (dBm).

Frequency (MHz)	Channel Bandwidth (MHz)	Power (dBm)				Total power (dBm)	ERP (dBm)
		Ant 1	Ant 2	Ant 3	Ant 4		
256QAM							
731.5	5	46.01	45.98	45.83	45.96	51.97	64.82
737.0	5	45.98	45.95	45.88	46.02	51.98	64.83
742.5	5	46.07	45.99	45.86	46.00	52.00	64.85
734.0	10	46.03	45.97	45.81	45.79	51.92	64.77
737.0	10	45.96	45.88	45.93	45.83	51.92	64.77
740.0	10	45.89	45.82	45.85	45.70	51.84	64.69
736.5	15	45.90	45.89	45.79	45.82	51.87	64.72
737.0	15	45.92	45.81	45.80	45.77	51.85	64.70
737.5	15	45.88	45.83	45.69	45.76	51.81	64.66
731.5+736.5	5 + 5	45.98	45.80	45.73	45.76	51.84	64.69
734.5+739.5	5 + 5	45.99	45.90	45.69	45.79	51.86	64.71
737.5 +742.5	5 + 5	45.89	45.89	45.80	45.68	51.84	64.69
731.5+742.5	5 + GAP6 + 5	46.00	45.86	45.87	45.81	51.91	64.76
731.5+739.0	5 + 10	46.01	45.89	46.03	46.00	52.00	64.85
732.5+739.5	5 + 10	45.92	45.86	45.76	45.86	51.87	64.72
732.5+740.0	5 + 10	45.96	45.85	45.88	45.81	51.90	64.75
731.5+740 .0	5 + GAP1 + 10	46.04	45.89	45.84	45.89	51.94	64.79

Note: Total Power (dBm) = $10 \cdot \log \{ 10^{[ANT 1 \text{ Power (dBm) / 10}] + 10^{[ANT 2 \text{ Power (dBm) / 10}] + 10^{[ANT 3 \text{ Power (dBm) / 10}] + 10^{[ANT 4 \text{ Power (dBm) / 10}]}} \}$ (dBm).

4.3. Frequency Stability Measurement

4.3.1. Test Limit

The frequency stability shall be sufficient to ensure that the fundamental emissions stay within the authorized bands of operation.

4.3.2. Test Procedures Used

KDB 971168 D01v03r01 - Section 9

ANSI C63.26-2015 - Section 5.6

4.3.3. Test Setting

Frequency Stability Under Temperature Variations:

The equipment under test was connected to an external AC or DC power supply and input rated voltage. RF output was connected to a frequency counter or spectrum analyzer via feed through attenuators. The EUT was placed inside the temperature chamber. Set the spectrum analyzer RBW low enough to obtain the desired frequency resolution and measure EUT 20°C operating frequency as reference frequency. Turn EUT off and set the chamber temperature to highest. After the temperature stabilized for approximately 30 minutes recorded the frequency. Repeat step measure with 10°C decreased per stage until the lowest temperature reached.

Frequency Stability Under Voltage Variations:

Set chamber temperature to 20°C. Use a variable AC power supply / DC power source to power the EUT and set the voltage to rated voltage. Set the spectrum analyzer RBW low enough to obtain the desired frequency resolution and recorded the frequency.

Reduce the input voltage to specify extreme voltage variation ($\pm 15\%$) and endpoint (If a product is specified to operate over a range of input voltage then the -15% variation is applied to the lowermost voltage and the $+15\%$ is applied to the uppermost voltage), record the maximum frequency change.

4.3.4. Test Setup

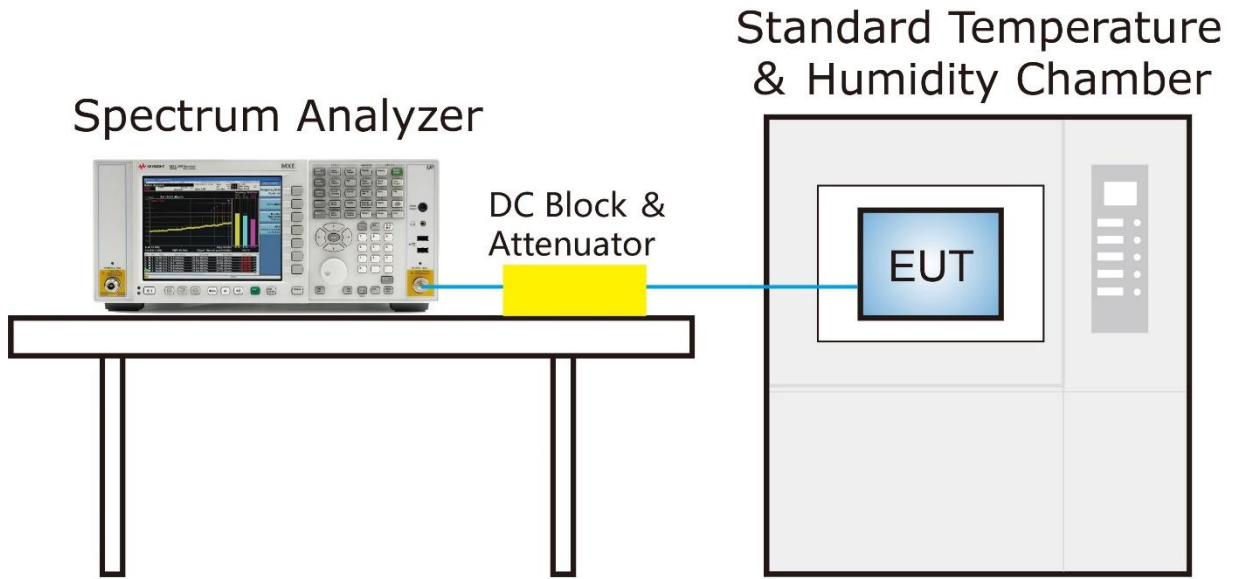

6.3.5. Test Result

Product	B12 4T4R 160W Radio Unit	Test Engineer	Larry Yan
Test Site	WZ-TR3	Test Date	2021/08/24
Test Confirmation	LTE Band 12 (Single Carrier), BW=15MHz, QPSK		

Voltage (DC)	Temp (°C)	Frequency Tolerance (ppm)
48V	- 30	-0.002
	- 20	0.003
	- 10	0.003
	0	0.001
	+ 10	0.001
	+ 20	-0.003
	+ 30	-0.003
	+ 40	0.002
	+ 50	0.002
40.8V	+ 20	0.003
55.2V	+ 20	-0.004

4.4. Emission Bandwidth

4.4.1. Test Limit

The emission bandwidth is defined as the width of the signal between two points, one below the carrier center frequency and one above the carrier center frequency, outside of which all emissions are attenuated at least 26 dB below the transmitter power.

4.4.2. Test Procedure

KDB 971168 D01v03r01 - Section 4.1 & 4.2

ANSI C63.26-2015 - Section 5.4.3 & 5.4.4

4.4.3. Test Setting

1. Set center frequency to the nominal EUT channel center frequency;
2. RBW = The nominal RBW shall be in the range of 1% to 5% of the anticipated OBW;
3. VBW $\geq 3 \times$ RBW;
4. Detector = Peak;
5. Trace mode = max hold;
6. Sweep = auto couple;
7. Allow the trace to stabilize;
8. The dynamic range of the spectrum analyzer at the selected RBW shall be more than 10 dB below the target “-X dB” requirement, i.e., if the requirement calls for measuring the -26 dB OBW, the spectrum analyzer noise floor at the selected RBW shall be at least 26 dB below the reference level

4.4.4. Test Setup

Spectrum Analyzer

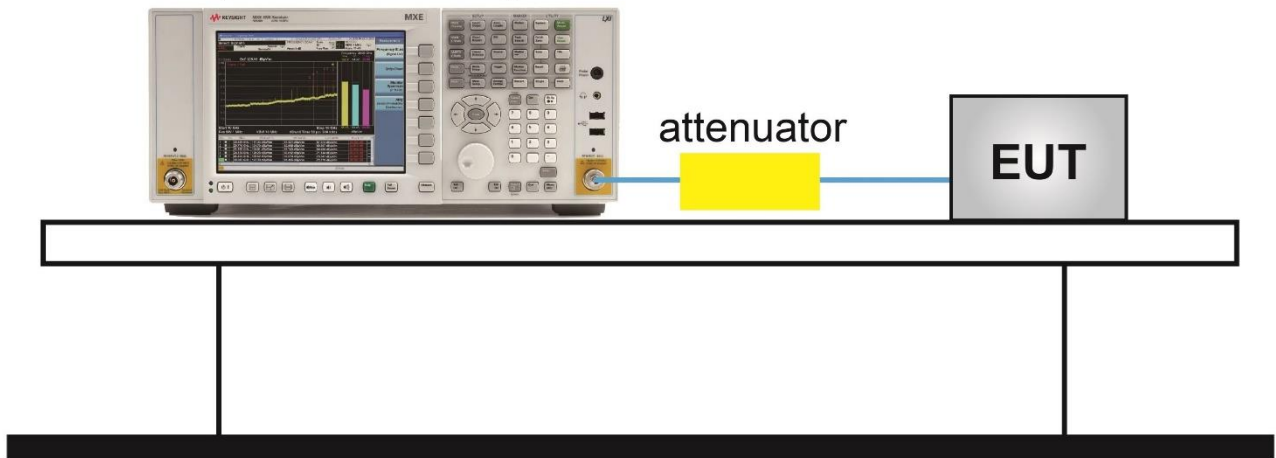

6.4.5. Test Result

Product	B12 4T4R 160W Radio Unit	Test Engineer	Larry Yan
Test Site	WZ-SR6	Test Date	2021/08/21
Test Configuration	LTE Band 12		

Frequency (MHz)	Bandwidth (MHz)	26dB Bandwidth (MHz)	99% Bandwidth (MHz)
QPSK			
731.5	5	4.75	4.48
737.0	5	4.76	4.47
742.5	5	4.76	4.48
734.0	10	9.50	8.94
737.0	10	9.50	8.95
740.0	10	9.50	8.95
736.5	15	14.58	13.40
737.0	15	14.50	13.40
737.5	15	14.63	13.41
731.5+736.5	5 + 5	9.87	9.43
734.5+739.5	5 + 5	9.87	9.43
737.5 +742.5	5 + 5	9.86	9.43
731.5+739.0	5 + 10	14.71	14.14
732.5+739.5	5 + 10	14.70	14.14
732.5+740.0	5 + 10	14.71	14.14
731.5+742.5	5 + GAP6 + 5	9.58	8.95
731.5+740.0	5 + GAP1 + 10	14.20	13.39

16QAM			
731.5	5	4.75	4.47
737.0	5	4.74	4.47
742.5	5	4.75	4.47
734.0	10	9.48	8.95
737.0	10	9.47	8.95
740.0	10	9.50	8.95
736.5	15	14.43	13.44
737.0	15	14.39	13.42
737.5	15	14.40	13.41
731.5+736.5	5 + 5	9.81	9.42
734.5+739.5	5 + 5	9.80	9.43
737.5 +742.5	5 + 5	9.83	9.44
731.5+739.0	5 + 10	14.71	14.15
732.5+739.5	5 + 10	14.72	14.16
732.5+740.0	5 + 10	14.72	14.15
731.5+742.5	5 + GAP6 + 5	9.47	8.95
731.5+740.0	5 + GAP1 + 10	14.16	13.43
64QAM			
731.5	5	4.75	4.48
737.0	5	4.75	4.48
742.5	5	4.76	4.48
734.0	10	9.47	8.95
737.0	10	9.46	8.94
740.0	10	9.50	8.95
736.5	15	14.52	13.44
737.0	15	14.45	13.44
737.5	15	14.49	13.40
731.5+736.5	5 + 5	9.84	9.42
734.5+739.5	5 + 5	9.84	9.45
737.5 +742.5	5 + 5	9.84	9.44
731.5+739.0	5 + 10	14.66	14.16
732.5+739.5	5 + 10	14.68	14.15
732.5+740.0	5 + 10	14.71	14.13
731.5+742.5	5 + GAP6 + 5	9.53	8.96
731.5+740.0	5 + GAP1 + 10	14.21	13.42

256QAM			
731.5	5	4.76	4.48
737.0	5	4.75	4.47
742.5	5	4.76	4.48
734.0	10	9.47	8.94
737.0	10	9.45	8.94
740.0	10	9.47	8.94
736.5	15	14.45	13.41
737.0	15	14.42	13.42
737.5	15	14.46	13.41
731.5+736.5	5 + 5	9.82	9.44
734.5+739.5	5 + 5	9.83	9.44
737.5 +742.5	5 + 5	9.84	9.44
731.5+739.0	5 + 10	14.72	14.15
732.5+739.5	5 + 10	14.71	14.15
732.5+740.0	5 + 10	14.72	14.15
731.5+742.5	5 + GAP6 + 5	9.51	8.95
731.5+740.0	5 + GAP1 + 10	14.26	13.41

5MHz Channel Bandwidth - QPSK

Bottom Channel

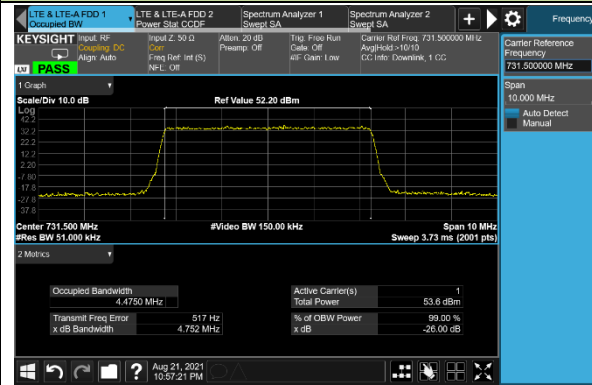

Middle Channel

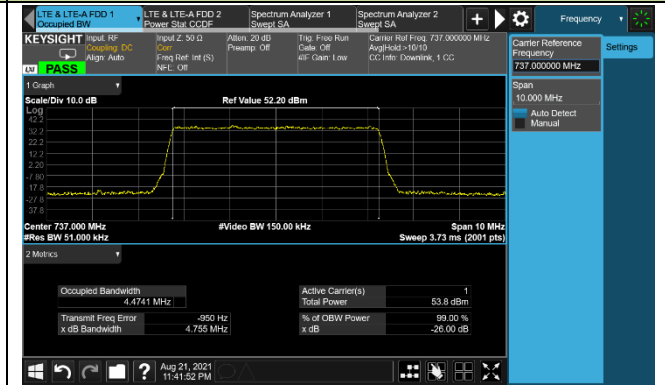

Top Channel

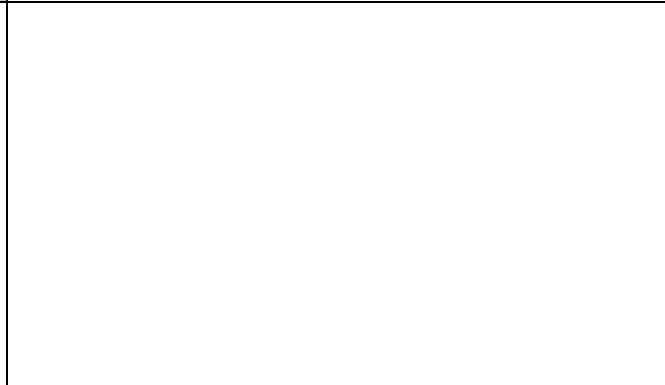
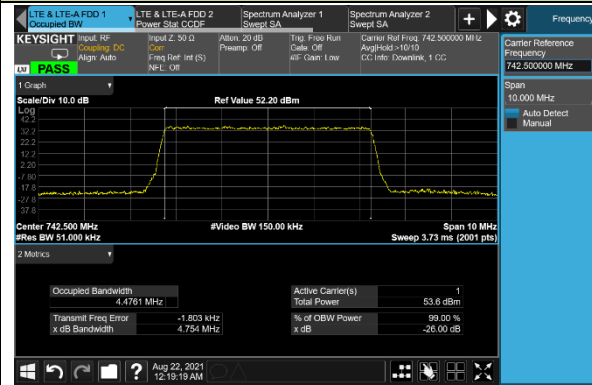

5MHz Channel Bandwidth - 16QAM

Bottom Channel

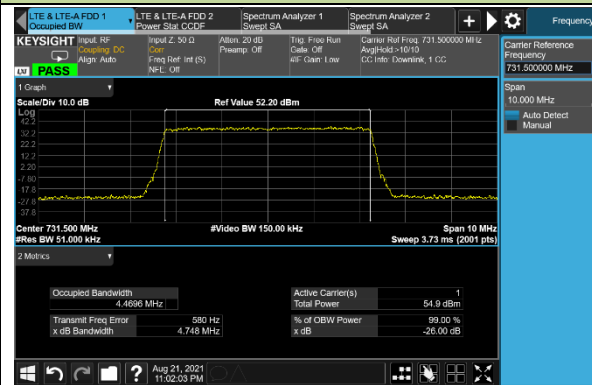

Middle Channel

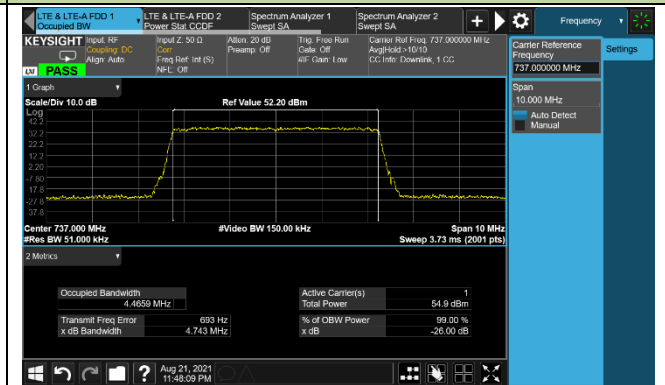

Top Channel

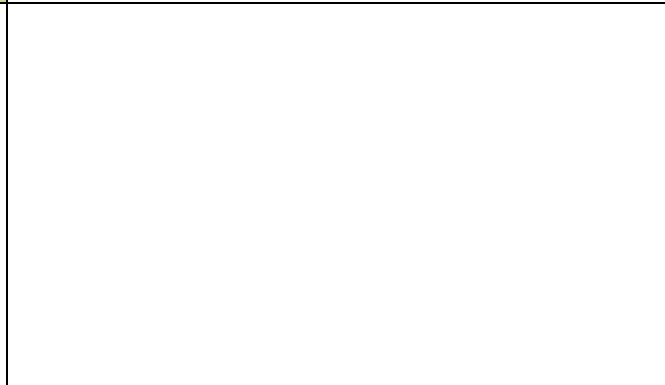
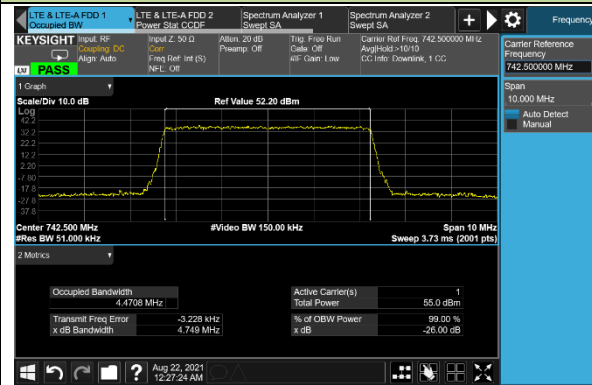

5MHz Channel Bandwidth - 64QAM

Bottom Channel

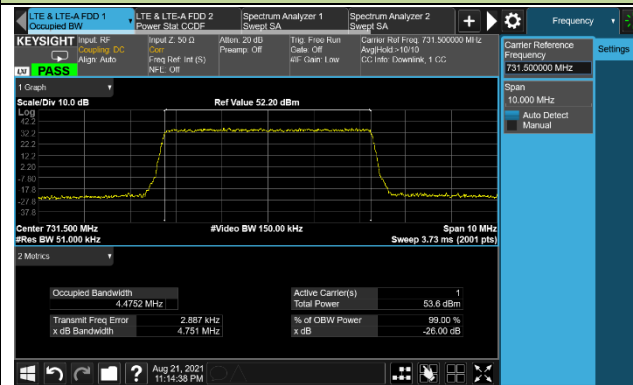

Middle Channel

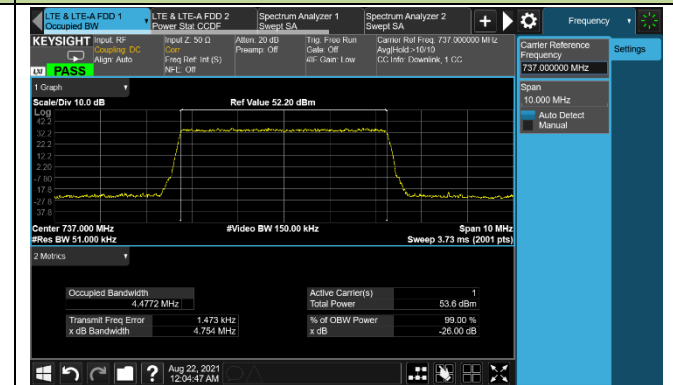

Top Channel

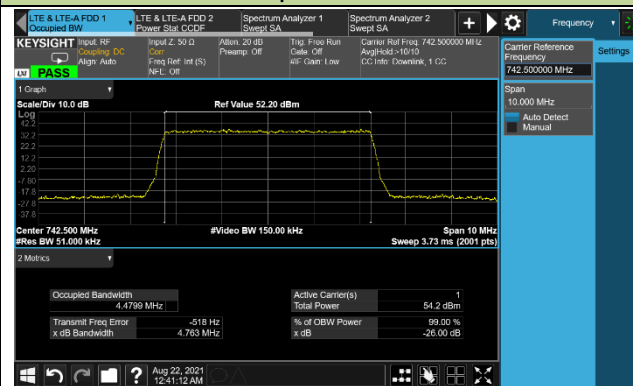

5MHz Channel Bandwidth - 256QAM

Bottom Channel

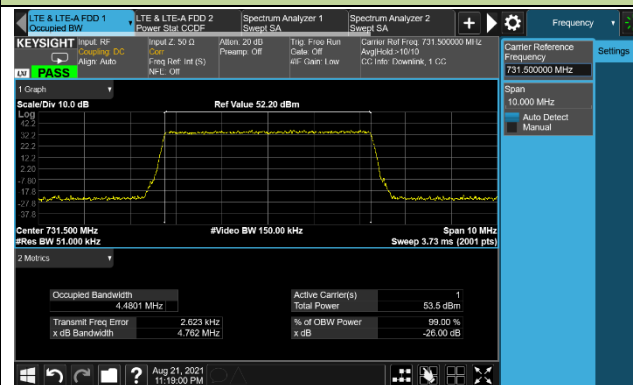

Middle Channel

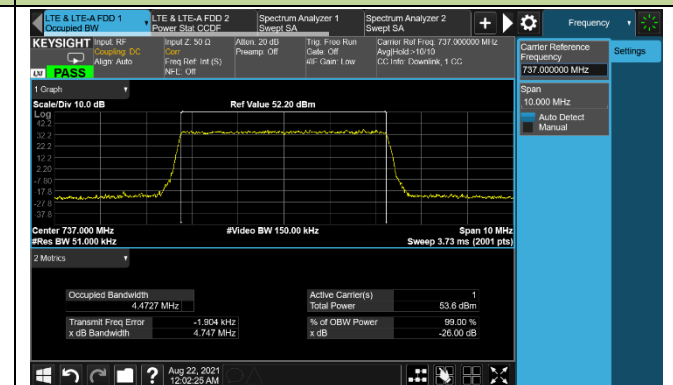

Top Channel

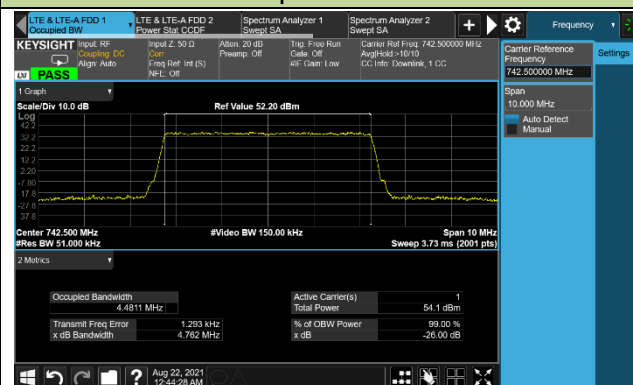

10MHz Channel Bandwidth - QPSK

Bottom Channel

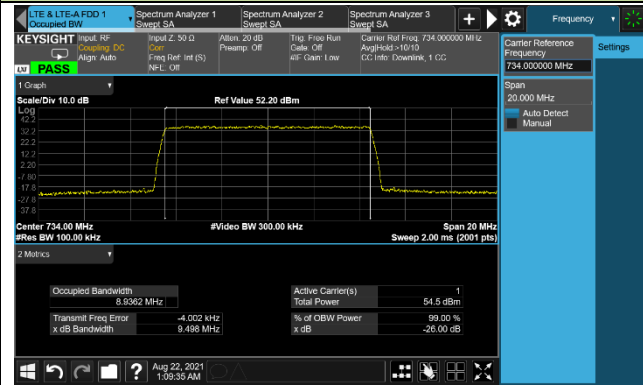

Middle Channel

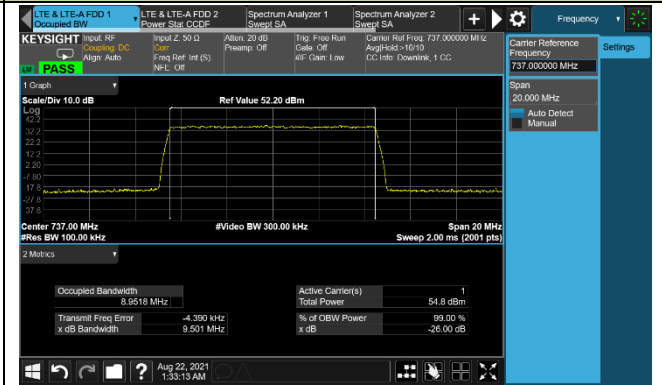

Top Channel

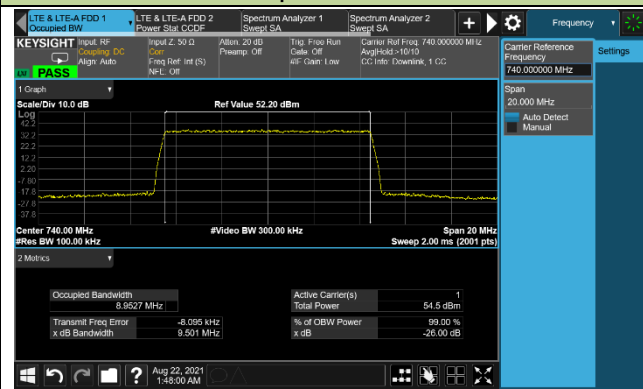

10MHz Channel Bandwidth - 16QAM

Bottom Channel

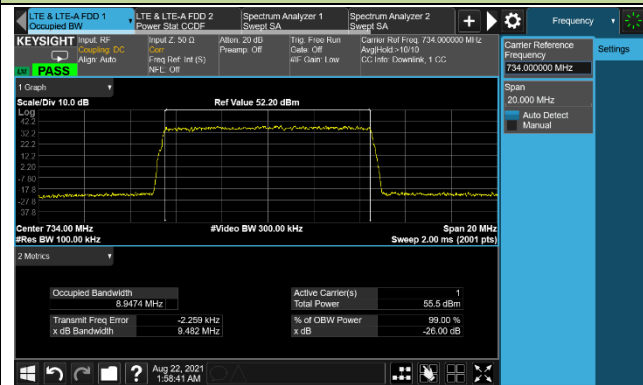

Middle Channel

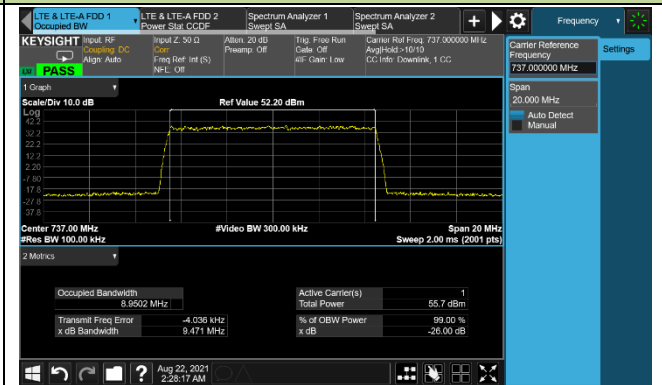

Top Channel

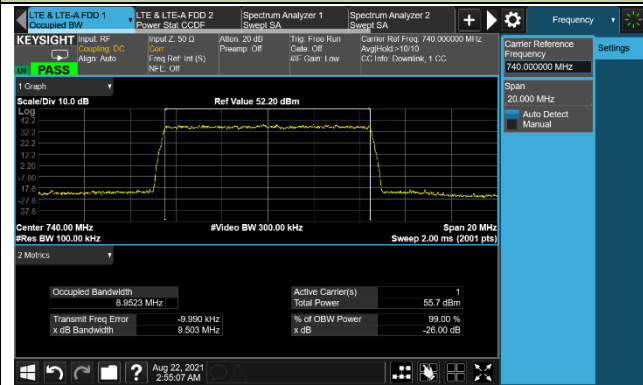

10MHz Channel Bandwidth - 64QAM

Bottom Channel

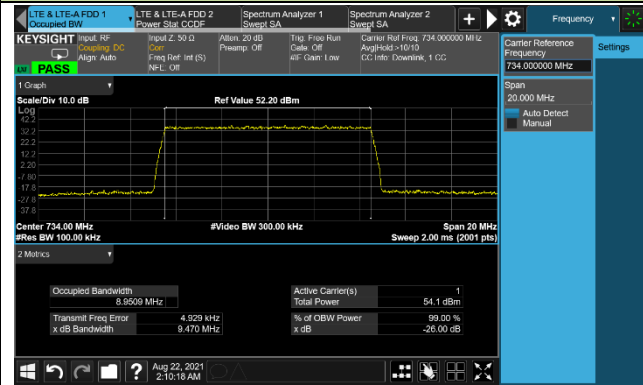

Middle Channel

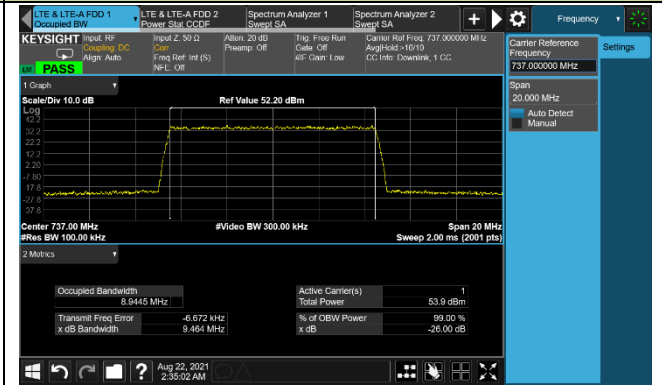

Top Channel

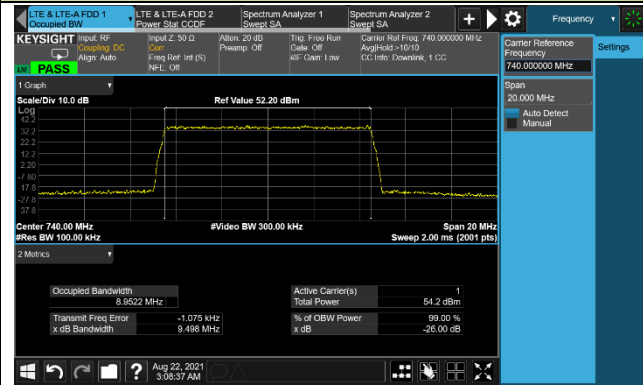

10MHz Channel Bandwidth - 256QAM

Bottom Channel

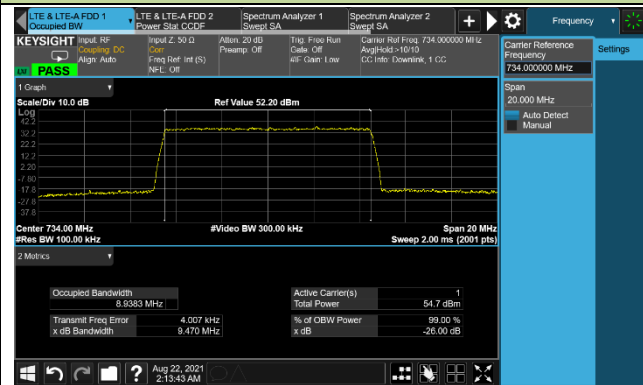

Middle Channel

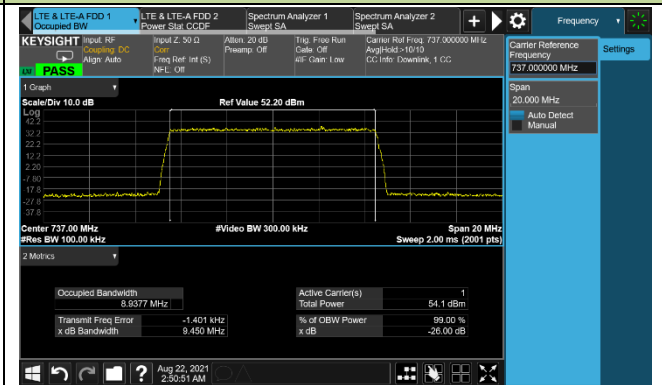

Top Channel

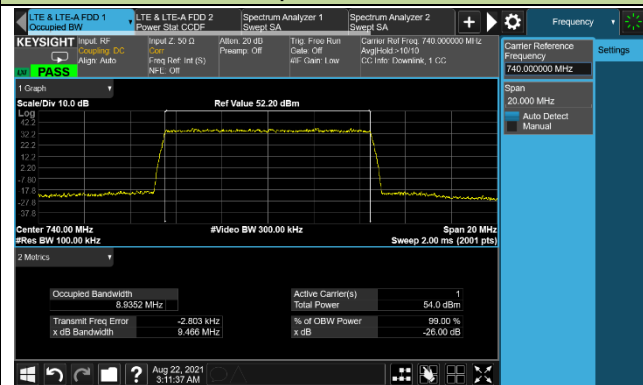

15MHz Channel Bandwidth - QPSK

Bottom Channel

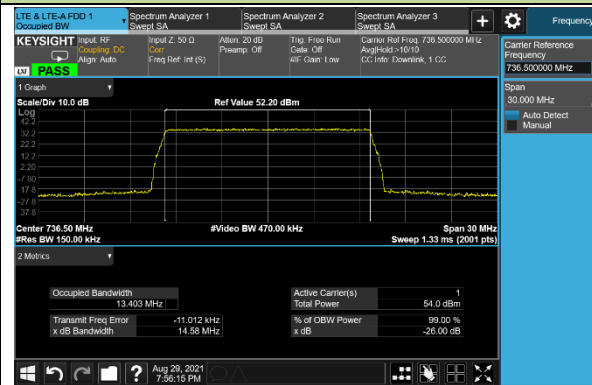

Middle Channel

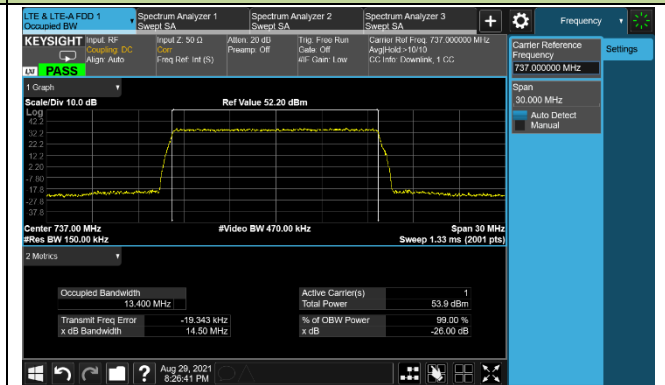

Top Channel

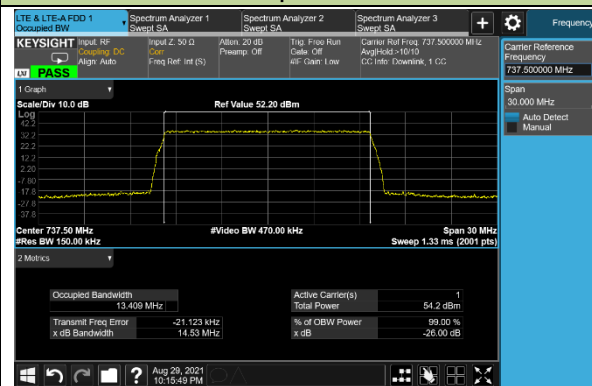

15MHz Channel Bandwidth - 16QAM

Bottom Channel

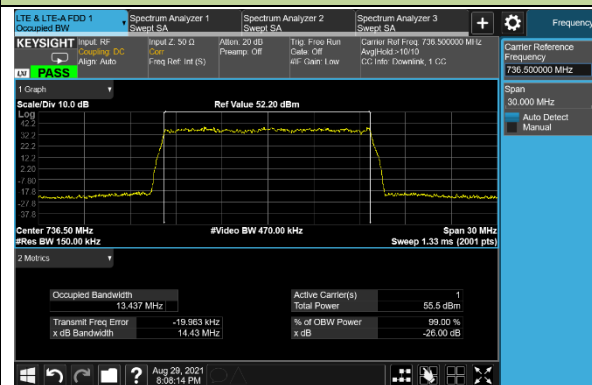

Middle Channel

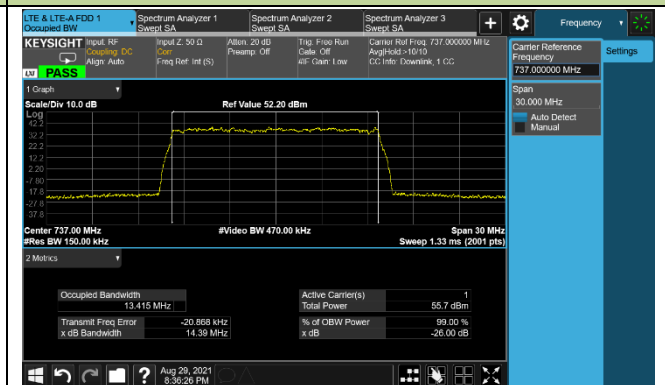

Top Channel

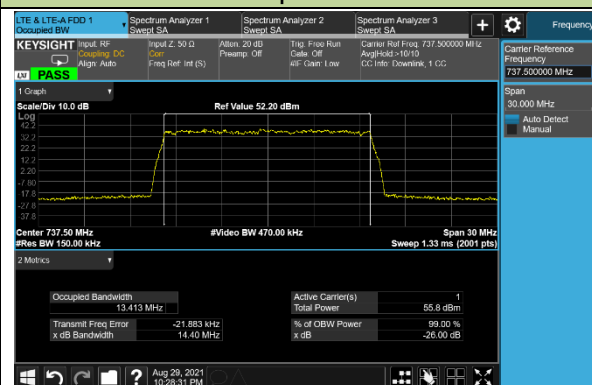

15MHz Channel Bandwidth - 64QAM

Bottom Channel

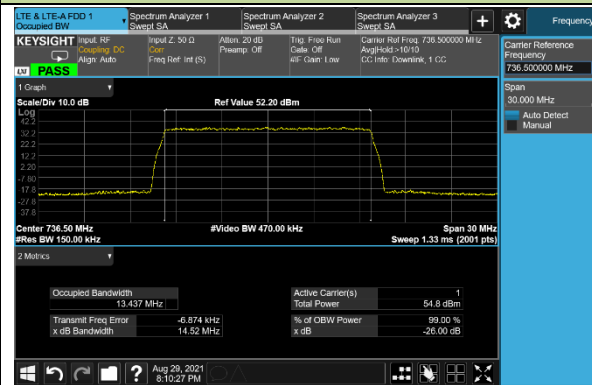

Middle Channel

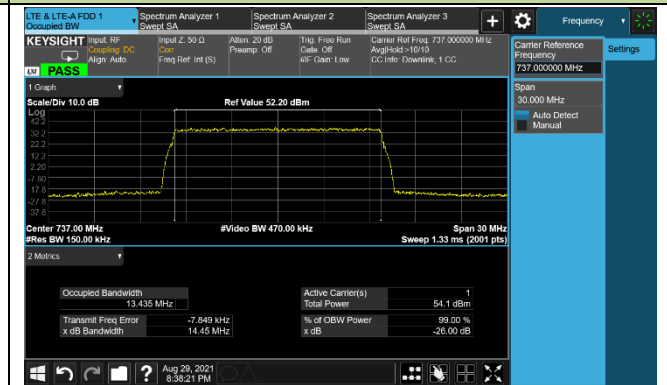

Top Channel

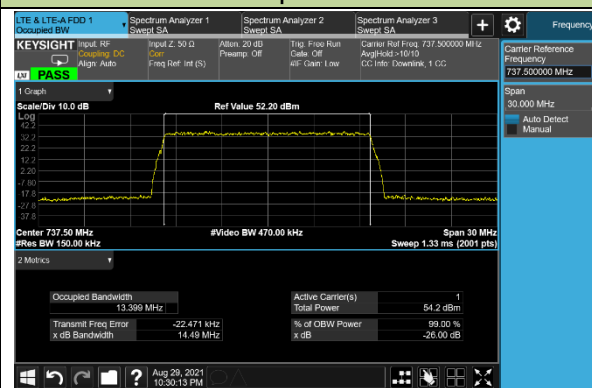

15MHz Channel Bandwidth - 256QAM

Bottom Channel

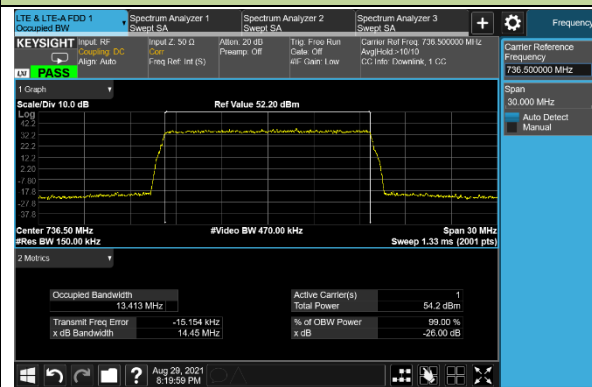

Middle Channel

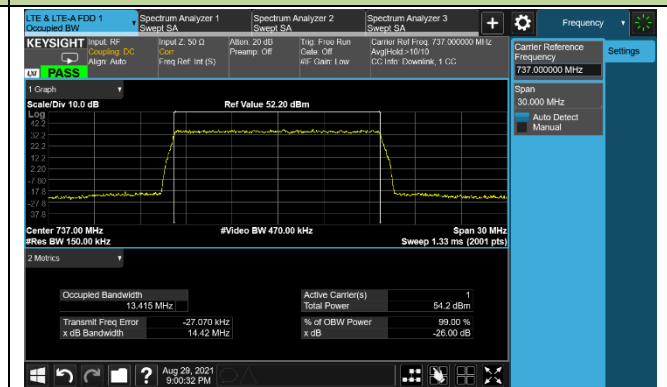

Top Channel

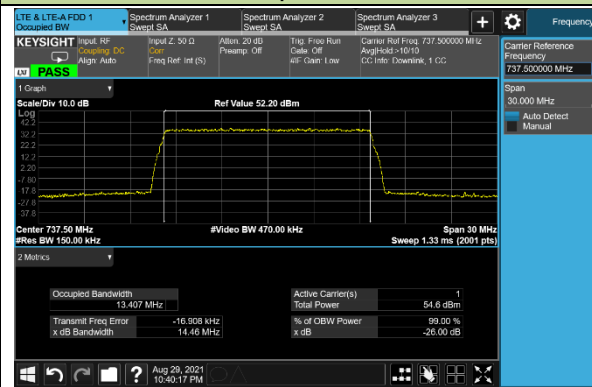

5+5MHz Channel Bandwidth - QPSK

Bottom Channel

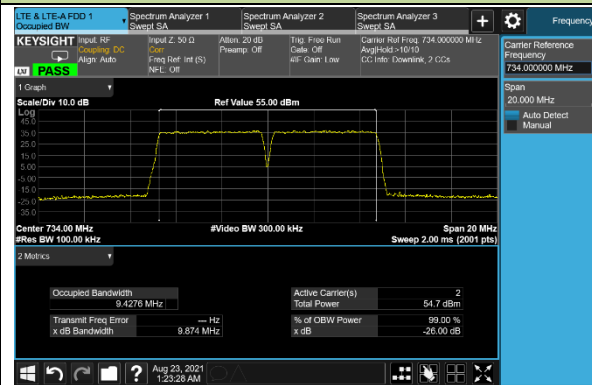

Middle Channel

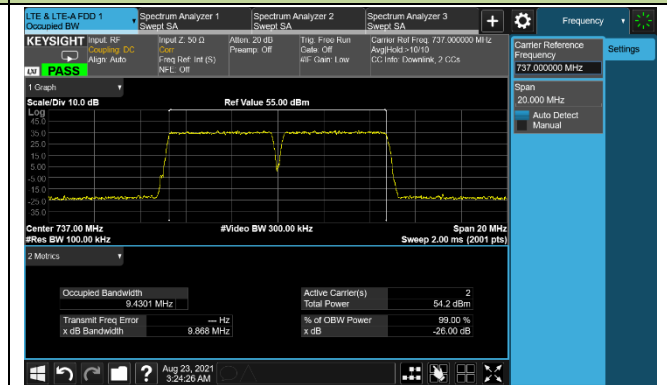

Top Channel

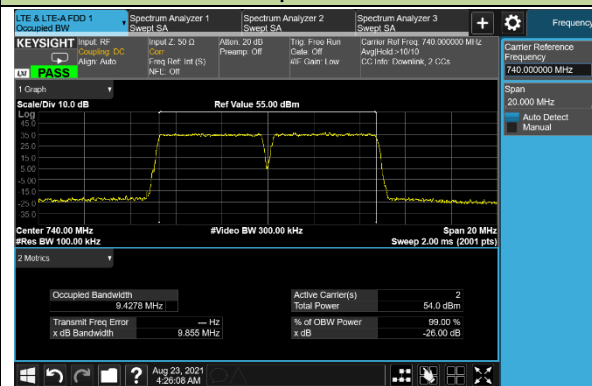

5+5MHz Channel Bandwidth - 16QAM

Bottom Channel

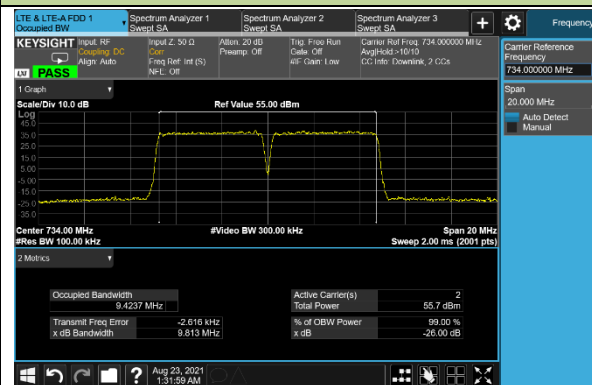

Middle Channel

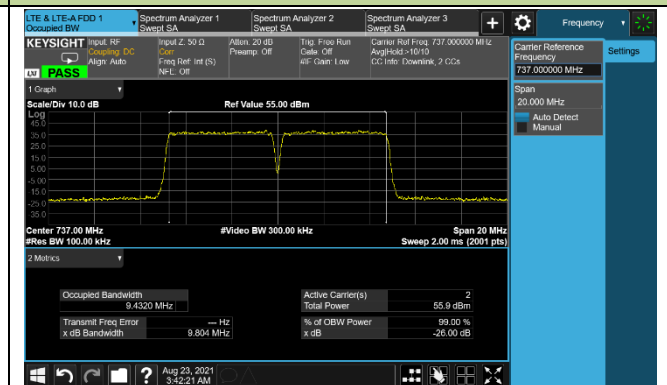

Top Channel

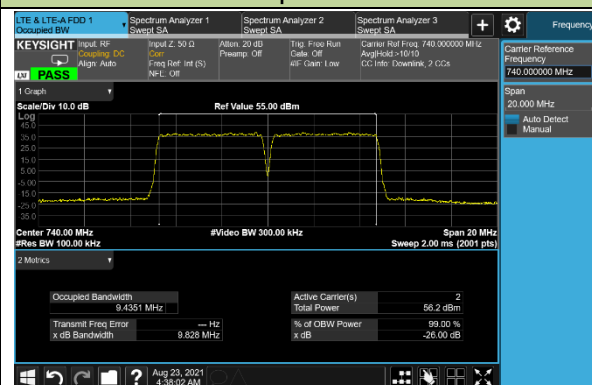

5+5MHz Channel Bandwidth - 64QAM

Bottom Channel

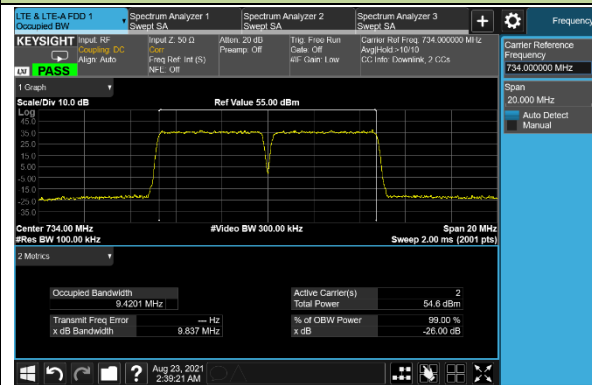

Middle Channel

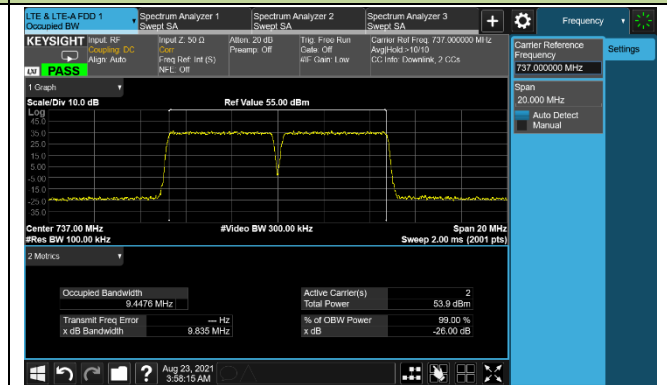

Top Channel

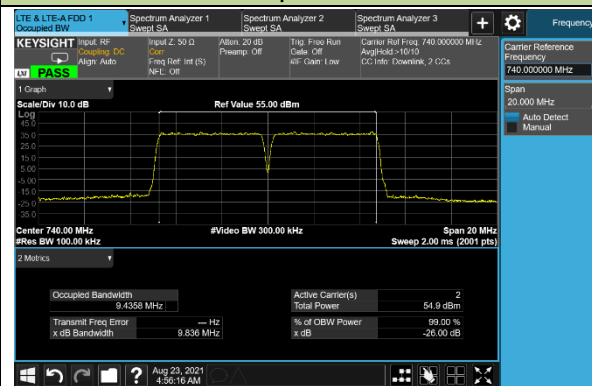

5+5MHz Channel Bandwidth - 256QAM

Bottom Channel

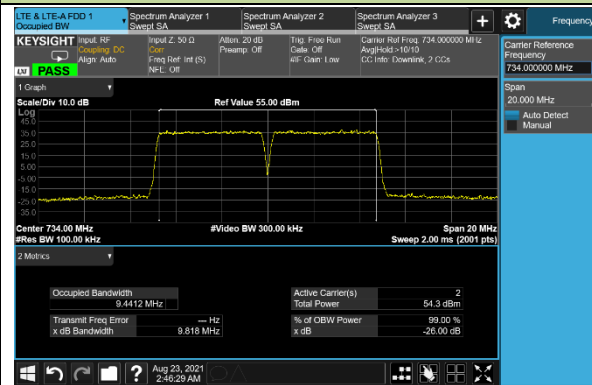

Middle Channel

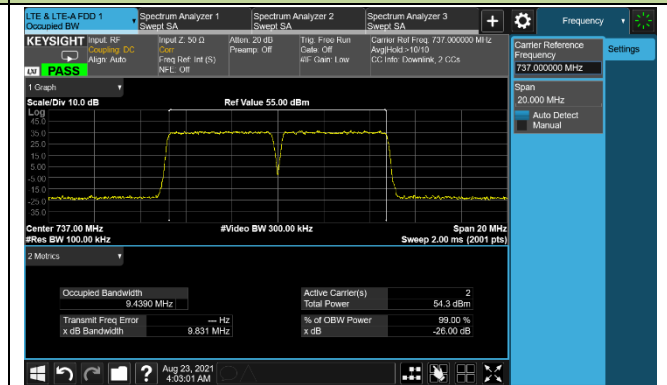

Top Channel

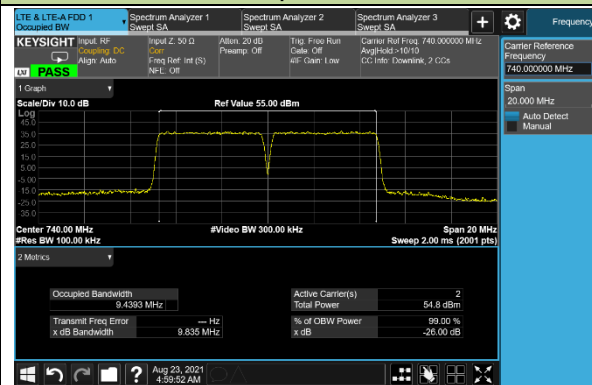

5+10MHz Channel Bandwidth - QPSK

Bottom Channel



Middle Channel

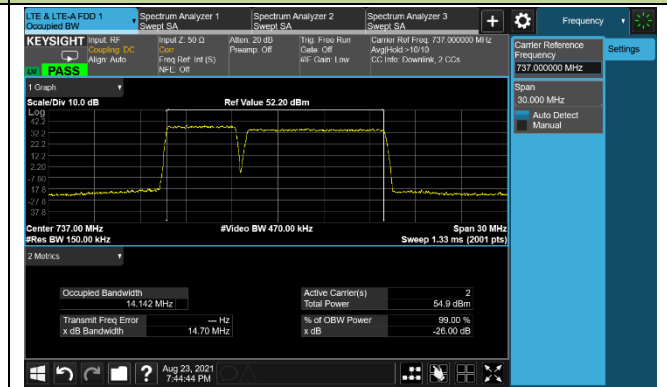

Top Channel

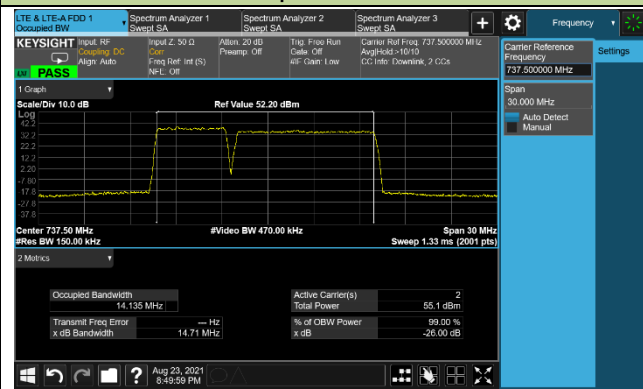

5+10MHz Channel Bandwidth - 16QAM

Bottom Channel

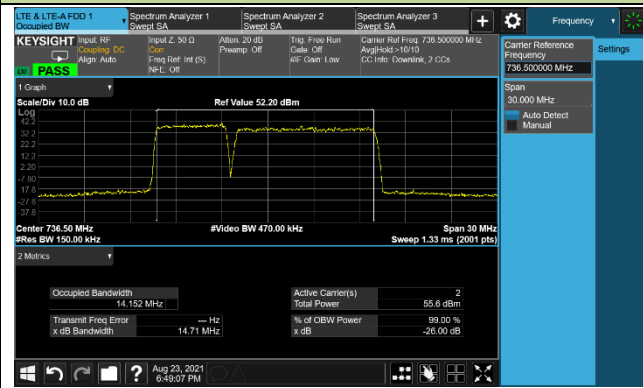

Middle Channel

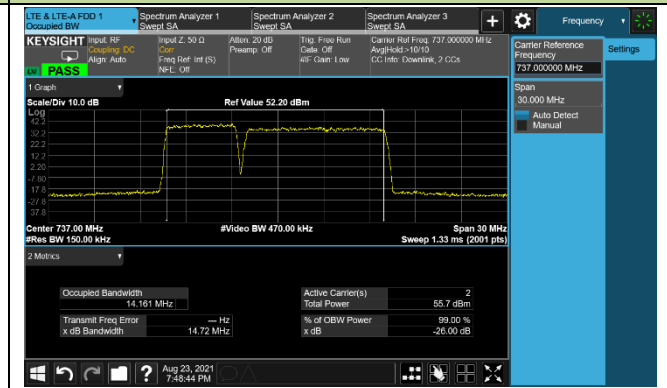

Top Channel



5+10MHz Channel Bandwidth - 64QAM

Bottom Channel

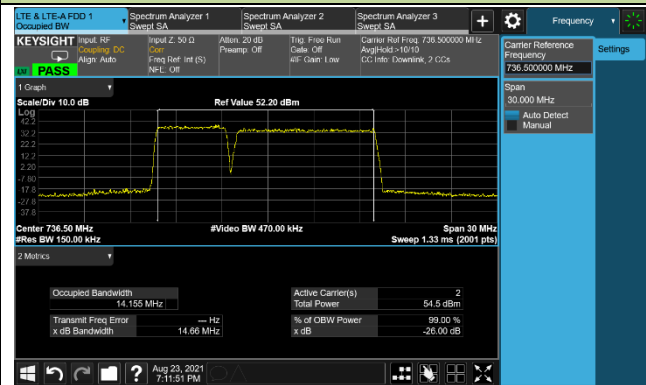

Middle Channel

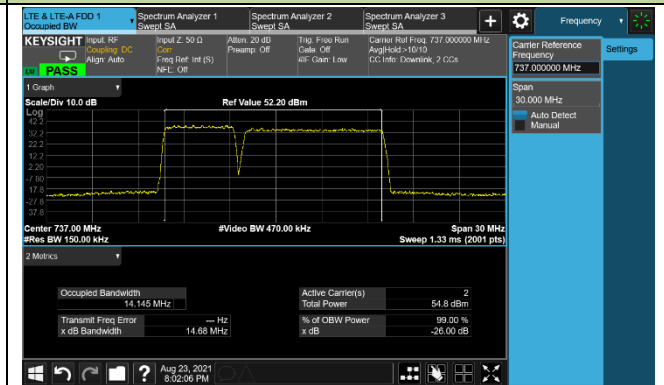

Top Channel

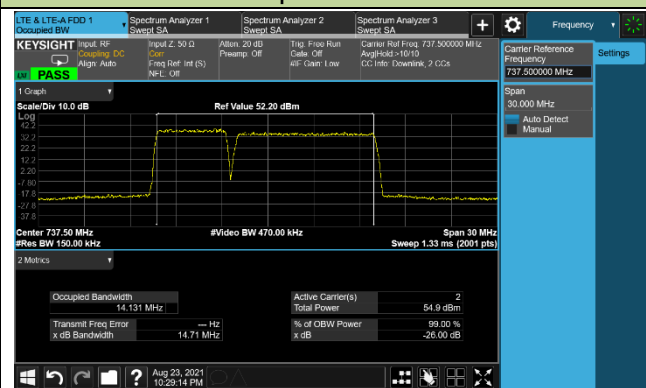

5+10MHz Channel Bandwidth - 256QAM

Bottom Channel

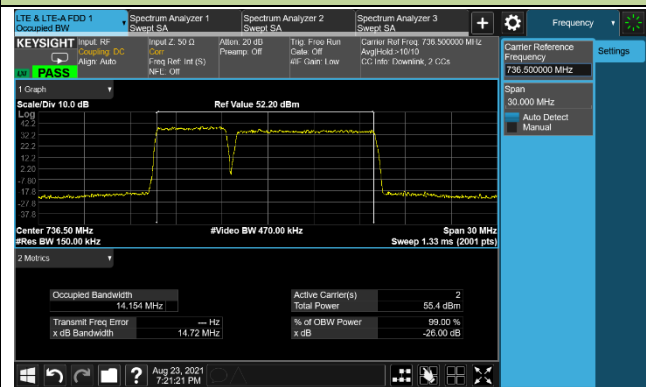

Middle Channel

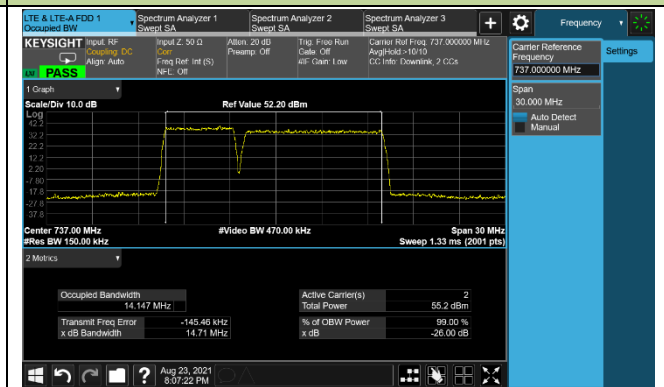

Top Channel

