

Video/Audio Baby Monitor

User Guide

Model: BM502



KEEP THIS USER GUIDE FOR FUTURE REFERENCE

SAFETY INSTRUCTIONS

Keep cord out of the reach of children (more than 3ft/0.9m away) in case of STRANGULATION.

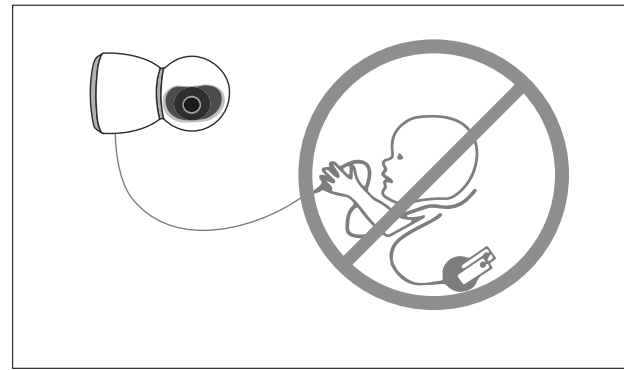
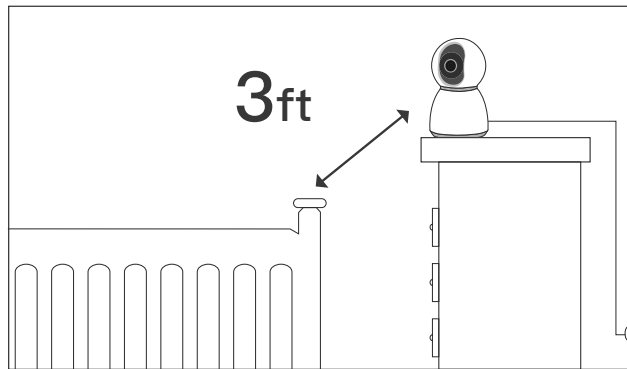

- NEVER place the camera or cord in or near the crib or playpen
- NEVER mount the camera directly above the crib or playpen to avoid the risk of injury.
- Only use the AC adapters provided
- Never use the unit near water, including near a bathtub, sink, laundry machine tube, wet basement, etc
- Do not install near any heat sources such as radiators, heat registers, stoves, or other devices that produce heat.
- Only use attachments and accessories specified by the manufacturer.
- Unplug this device when unused for long periods of time.
- Do not insert anything into the upgrade pinholes. This operation is only intended for professionals.

CAUTION

- NOT toys. Do not allow children to play with them.
- The lens and lens hood are small parts, keep them out of your baby's reach at all times.
- This product is NOT intended to replace the proper supervision of children. You MUST check your child's activity regularly.
- This product is not intended for use as a medical camera and its use should not replace adult supervision.
- Unplug the product during lightning storms.
- Please check the operating range and condition of the camera carefully at the initial installation, and on a regular basis after that.
- Check the reception regularly. Test the camera before use and after changing the camera's location.
- For indoor use only.
- Clean the camera with a dry cloth only.
- Do not block any ventilation openings.
- Microphone feedback might occur when the monitor is too close to the camera. Please keep them at least 1.5m / 4.9ft apart.

PACKAGE CONTENTS

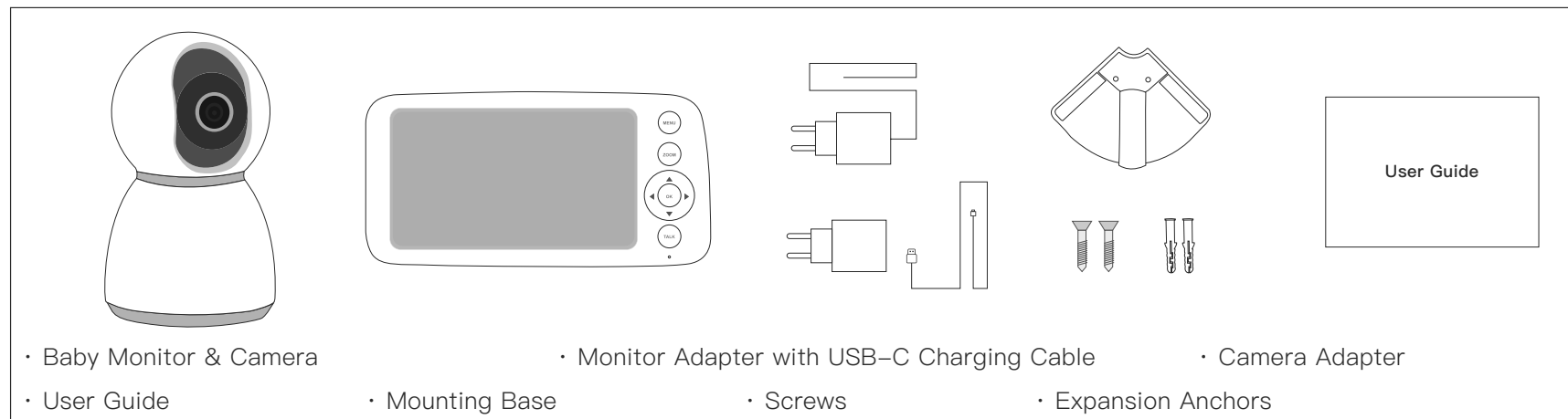

PRODUCT DIAGRAM

Baby Monitor

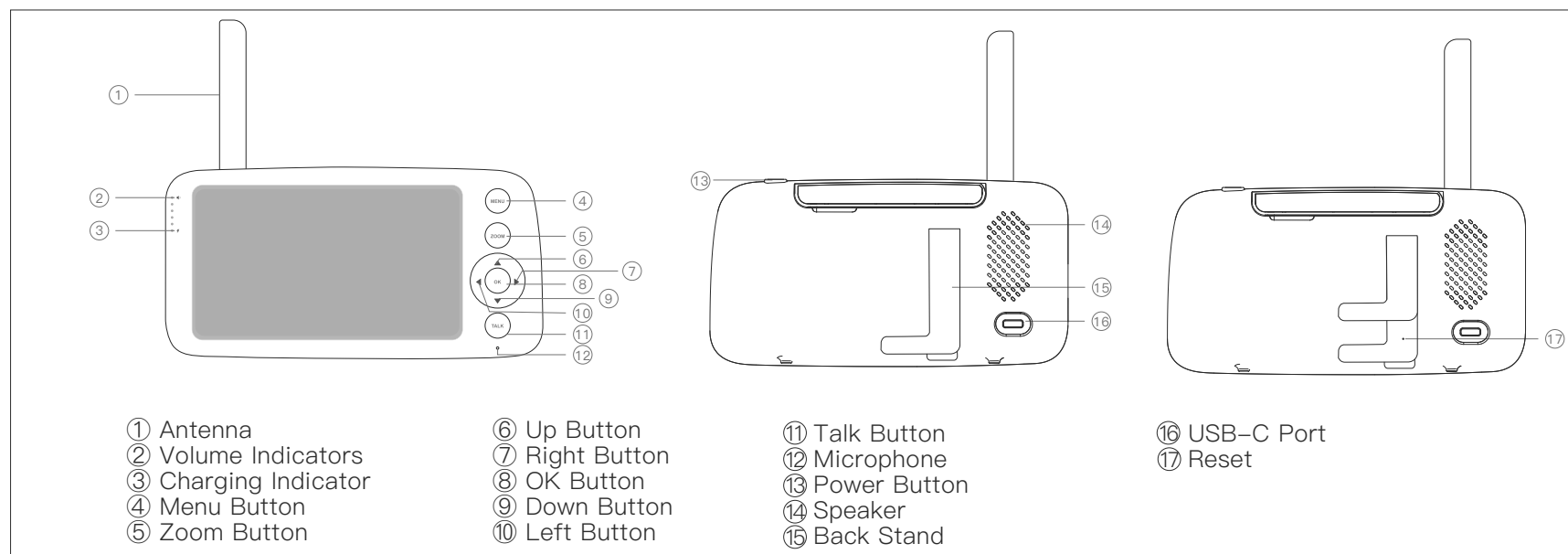

PRODUCT DIAGRAM

Baby Monitor

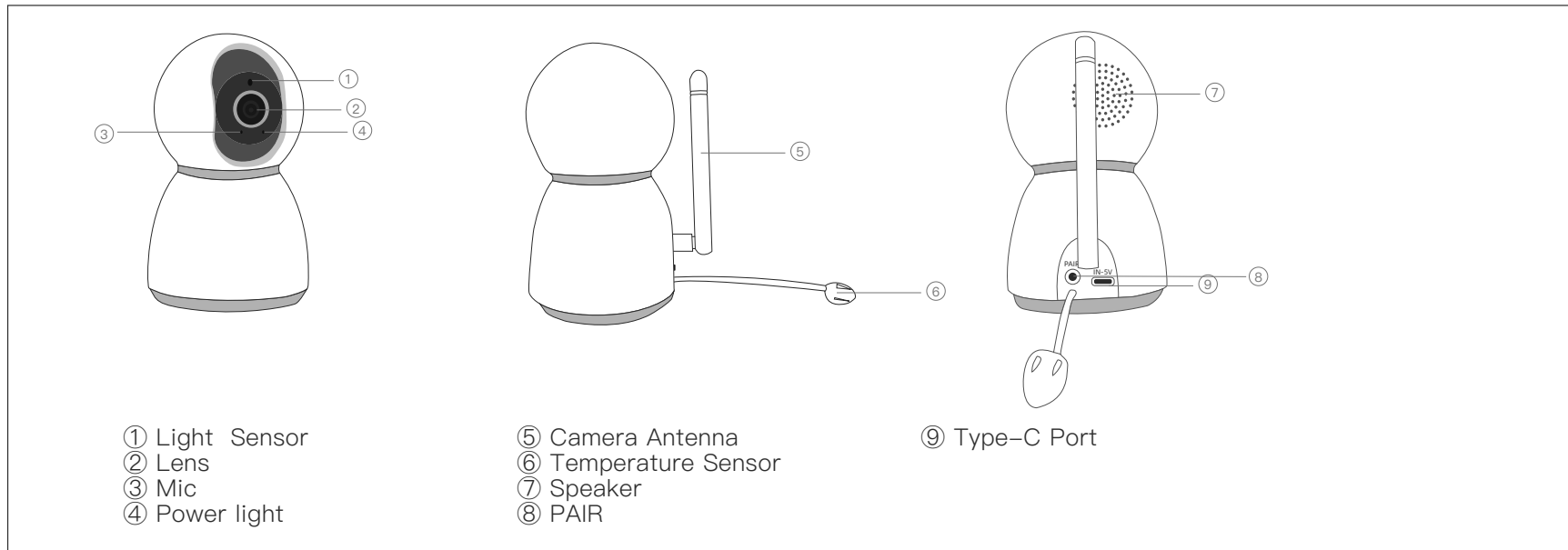

GETTING STARTED

1. Charging & Powering Baby Monitor

- 1) Connect the monitor adapter to the monitor and a power outlet.
- 2) Unplug the unit when its power indicator turns off, indicating a full charge.
- 3) Press the Power Button on the monitor to power on. The green power indicator light will be on.



2. Powering Camera

Connect the camera to power source via the USB-C cable and camera power adapter.



- * Only use the power adapters included in the package.
- * Do not place the camera and power cord within the reach of your baby.

3. Pairing the Baby Monitor & the Camera

By default, one camera has been paired with the monitor when manufactured. When you power on the monitor and camera, the two will automatically pair. To add more cameras, Press and hold the button on the back of the camera, and the indicator flashes red, press Menu button, select through  ->  -> , and then the monitor will auto-pair with the camera.



- * Once they're paired successfully, the camera number with icon  1 will be shown at the top left.
- * Microphone feedback might occur when the monitor is too close to the camera. Please keep them at least 1.5m / 4.9ft apart.
- * It is recommended to pair in the baby's room, or wherever you intend to place the camera.

4. Placing the Camera

Place the camera 1.5–2m / 4.9–6.6ft away from your baby for safety reason and for a better view when in night vision mode.

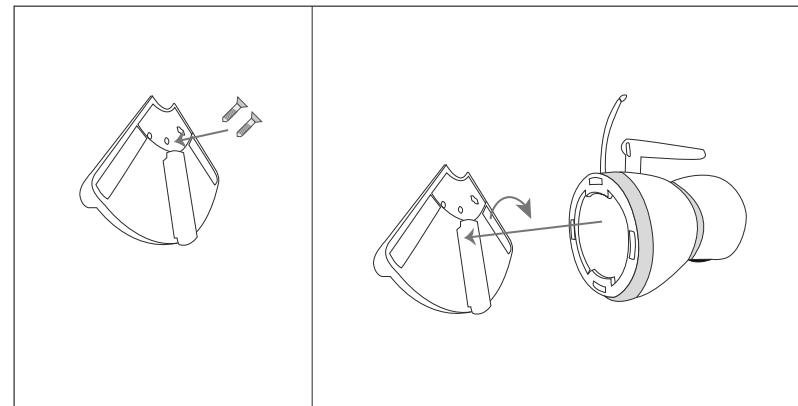
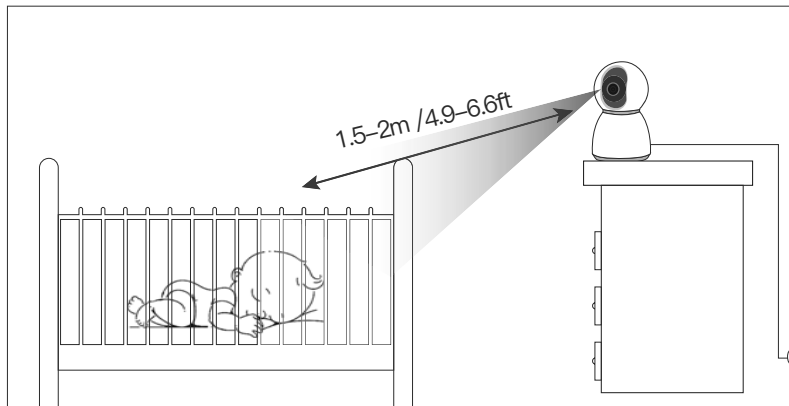

5. Wall Mounting Camera

- 1) Select the spot to mount the camera, keeping it beyond your baby's reach.
- 2) Use screws to mount the base on the wall. Align the bottom of the camera with the base and rotate clockwise to secure it.



- * It's strongly recommended to use a screw and an expansion anchor. Don't release the camera until you're sure it is securely mounted.

FUNCTIONS & OPERATIONS

Monitor Interface Overview

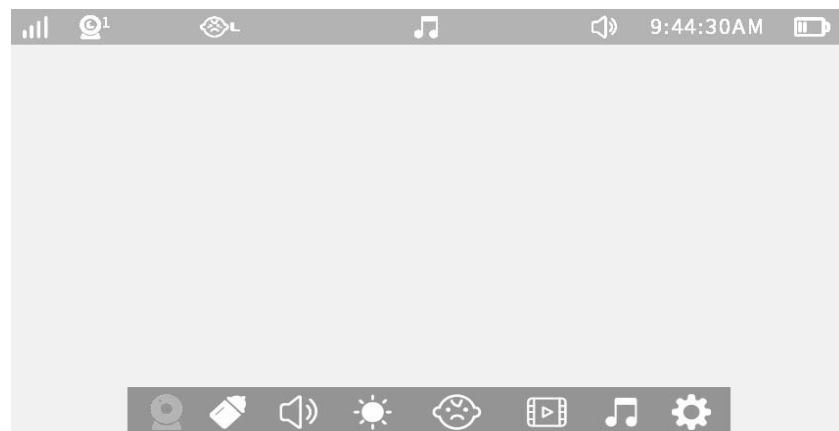

Top Status Indications







	Signal	4 levels		Mute	Mute all system sounds
	Current Camera	Camera 1 / Camera 2 / Camera 3 / Camera 4		Current Time	AM/ PM
	Current Temperature	°C / °F		Battery	4 levels
	Alarm	3 sensitivities (L–M–H)		Zoom	Zoom In (1X) / Zoom In (2X)

Bottom Menu Brief

	Cameras	Add/Delete/View cameras		Brightness	0–7
	Feeding time	Set feeding time or time interval (1h, 2h, 3h)		Baby crying detection	3 sensitivities (L–M–H)
	Speaker volume	0–7		Lullaby	10 songs
	Settings	Set monitor to display temperature in °C/°F, set screen sleep, set date and time, set background color, and view version number.			

Monitor Settings







Press Menu Button, Left and Right Buttons, and then Ok Button to set the monitor:

- 1)  **Temperature scale:** Select between °C and °F.
- 2)  **Screen auto-sleep time:** Select between 1min, 3min, 5min, and OFF.
- 3)  **Time setting:** Set the current time by setting hour, minute, and AM/ PM.
- 4)  **Background color:** Set the background color of the operating system.
- 5)  **Restore to factory settings:** Press OK Button to confirm resetting; “Restoring factory settings” will be shown when restoring, and you can’t press any button to control the device during this period. The monitor will auto restart when it’s done.
- 6)  **Customer service contacts:** Find the customer service email and phone number.



- * To mute the sound during poor monitor-camera connection, please set the  system sound volume to mute.
- * When the monitor screen is under sleep mode, the power indicator flashes green slowly. The audio is still on. Press any button to awake. You can also press the Power Button once to turn the screen off.
- * Press and hold the Power Button to power on / off the monitor.

2. Add / View / Delete a Camera

- 1) Press Menu button, then select the camera icon . Click the add camera icon , then choose a number  to add a camera.
- 2) Click the view icon  and choose a number  to view that camera.
- 3) Click the delete icon  and choose a number  to delete that camera..



After switching between viewing different cameras, the current camera number will be shown with the Camera icon  on the monitor.

3. Digital Zoom

Press and hold the Zoom Button to zoom in to 1X/2X when viewing the camera. A third pressing of the button will restore to the original image.



* The current zoom level number will be shown with the Zoom icon  on the monitor

4. Pan-n-Tilt

When viewing the camera, press Left/Right/Up/Down Buttons to view at different angles. You can move 90 degrees vertically and 360 degrees horizontally.

5. Volume Adjustment

Press OK Button → Right/Left Button to adjust volume up or down.



* For system sound adjustment, click Menu Button, then select the volume icon . Press OK Button and adjust with Up/Down Buttons.

6. Brightness Adjustment

Press OK Button → Up/Down Button to adjust brightness up or down.

7. Night Vision

Night vision is automatically activated in dim environments. The camera has 6 high-intensity infrared LEDs for picking up clear images in the dark. Black and white images can be captured within a distance of 7 ft/2 m.

8. Cry Detector

When the baby cries, an alert will sound. Press Menu Button, then click the Cry Detector icon  to open Cry Detector menu. Click OK Button, then use Up/Down/Left/Right Buttons to select different sensitivity levels.



* The baby crying detector icon  will be displayed at the top when this function is turned on.
* This function cannot completely replace adult care of the baby. Please make sure to monitor the baby carefully.

9. Talkback

Press the Talk Button to talk to your baby. Press again again to exit talking mode.



- * When you enter the talking mode, the icon  will be shown on the monitor.
- * When the device is muted or the speaker volume is too low, you may not be able to hear the baby.
- * In one-way call mode, when you're pressing the Talk Button, you will not hear sound from the camera. Release the button to listen to your baby.

10. Temperature Alert

The monitor will prompt too high ($>30^{\circ}\text{C}/86^{\circ}\text{F}$) and too low ($<12^{\circ}\text{C}/53.6^{\circ}\text{F}$) temperatures, accompanied with a  icon and a beep alert.





- * When the monitor is muted, you may not be able to hear the baby!

11. Split Screen

When connected to multiple cameras, press and hold the Zoom Button to view multiple cameras simultaneously with split screen mode. Press Left/Right Buttons to choose a camera. Press and hold again to exit split screen mode and only display the selected camera.

12. Feeding Alarm

Press Menu button, then select the feeding alarm icon . Click the time icon  to set a specific time, or the alarm clock icon  to choose between 2h, 3h, 4h, or OFF.

SPECIFICATIONS

Monitor

Model	BM502	Brightness	8 levels
Image Aspect	16:9(HD720)	Antenna	Rotatable (max. 90 degree)
Resolution	IPS(720 x 1280),PPI=293	Power Input	5V /2A
Connectivity	915MHz	Zoom	Zoom In (1X) / Zoom In (2X)
Operating Range	Rotatable (max. 90 degree)	Two-Way Talk	Yes
Temperature Alert	Yes	Multi-Camera	Max. 4 cameras
Volume Control	8 levels	Storage Temperature	-10°C~55°C /14 -131°F
		Operation Temperature	0°C-40°C/32-104°F

Camera

Cmos	1080p(1920*1080)	Light Sensor	Yes
Connectivity	900MHz / 860MHz	Night Vision	Black & White image, up to 2m clear range
Pan-n-Tilt	90 degrees vertical(Up=60, Down=30) / 360 degrees horizontal (Left=180, Right=180)	IR LED	Non-visible IR LED with wavelength 940nm (x 6)
Power Input	5V /2A	Zoom	Zoom In (1X) / Zoom In (2X)
Two-Way Talk	Yes	Storage Temperature	-10°C~55°C /14 -131°F
		Operation Temperature	0°C-40°C/32-104°F

TROUBLESHOOTING

Product not powering on?	<ul style="list-style-type: none"> * Check that the camera and monitor are turned on. * Check the camera is connected to power properly (it cannot be charged; it will turn off once disconnected from power). * Check that the monitor has enough battery .
Baby monitor can't connect with the camera?	<ul style="list-style-type: none"> * Check whether the camera is near the monitor (recommended to keep within 5–7 ft/1.5–2m). * Check whether the monitor has a low battery. Charge it promptly to restore good connection. * Check whether the camera is connected to power. * Check whether there are any large metal objects including doors, refrigerators, mirrors, etc. between the camera and monitor that could be blocking the radio signal. * Check whether there's any other 900MHz/860MHz product being used nearby which may interfere the connection. * If none of the above apply, try to pair again.
Nothing shown when I view a camera?	<ul style="list-style-type: none"> * Check all connections to the camera (power cable plugged in and camera paired). * Check whether the screen is in sleep mode. Press any button to awake it. * Check whether the camera is within range of the monitor. * Adjust the monitor antenna to vertical position for better signal reception
No sound from the monitor?	<p>Check the system sound setting. If it's low or muted, you may not hear it.</p>
Black and white pictures?	<p>Night vision LED may be ON. Turn on room lights turn off this mode.</p>
Choppy videos?	<ul style="list-style-type: none"> * Check whether the camera is near the monitor and that there are no obstacles between them. * Adjust the monitor antenna to vertical position for better signal reception.
Too much noise?	<ul style="list-style-type: none"> * Volume may be set too high. Press →OK Button → Left Button to turn volume down. * The camera and monitor may be too close together; keep them at least 5 ft/1.5m apart.

This device complies with part 15 of the FCC Rules. Operation is subject to the following two conditions: (1) This device may not cause harmful interference, and (2) this device must accept any interference received, including interference that may cause undesired operation.

FCC warning:

Any Changes or modifications not expressly approved by the party responsible for compliance could void the user's authority to operate the equipment.

Note: This equipment has been tested and found to comply with the limits for a Class B digital device, pursuant to part 15 of the FCC Rules. These limits are designed to provide reasonable protection against harmful interference in a residential installation. This equipment generates uses and can radiate radio frequency energy and, if not installed and used in accordance with the instructions, may cause harmful interference to radio communications. However, there is no guarantee that interference will not occur in a particular installation. If this equipment does cause harmful interference to radio or television reception, which can be determined by turning the equipment off and on, the user is encouraged to try to correct the interference by one or more of the following measures:

- Reorient or relocate the receiving antenna.
- Increase the separation between the equipment and receiver.
- Connect the equipment into an outlet on a circuit different from that to which the receiver is connected.
- Consult the dealer or an experienced radio/TV technician for help.

The device has been evaluated to meet general RF exposure requirement. The device can be used in portable exposure condition without restriction.