

# MOUNTING INSTRUCTIONS

CHARGER STATION

LITUM<sup>®</sup> TAG CHARGER STATION

- Position the wall mount bracket in the desired position and mark the location of the mounting holes on the wall surface.
- When hanging the product on the wall, the distance between the highest point of the product and the ground should be a maximum of 2 meters.
- Ensure the area behind the mounting surface is always free of electrical wires, cables, and pipes before cutting, drilling, or installing the mounting screws.
- **DO NOT put on a glass surface.**
- Mount bracket to the wall using the appropriate mounting hardware required for the type of wall material fixture.
- Drill based on the marked mounting holes on the wall surfaces.
- Secure the wall bracket in position by installing mounting hardware over the mounting holes on the wall bracket tightly.
- Mark the positioning of the mounting holes on the wall surface and proceed with the installation accordingly.
- The charging station is exclusively designed for use with Litum's Badge Tag and Compact Tag.

## Devices

## Charger Station

In This Box You Will Find:

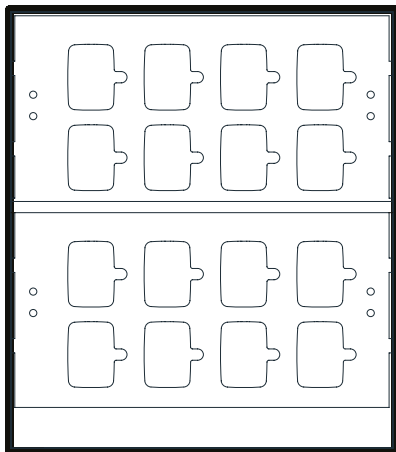

✓ Charger Station

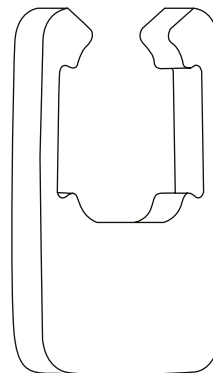

✓ Compact Tag Holder

✓ Power Cable

**1**

**DRILL & INSERT WALL PLUGS**

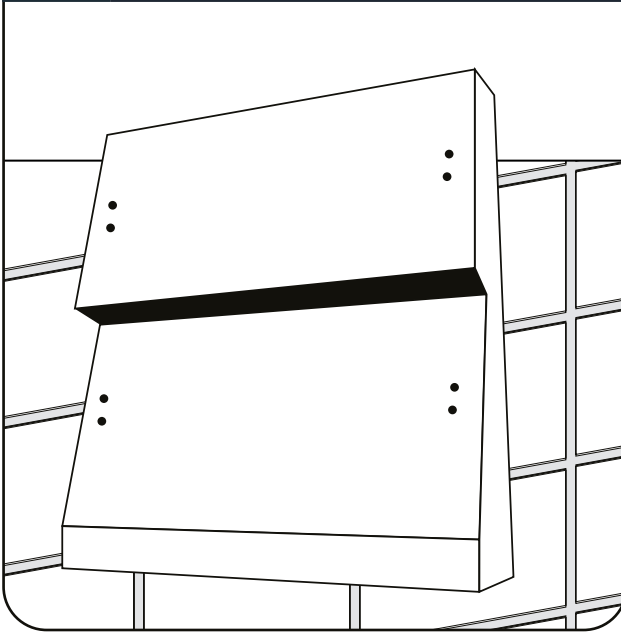

**2**

**PLACE IT ON A FLAT SURFACE**

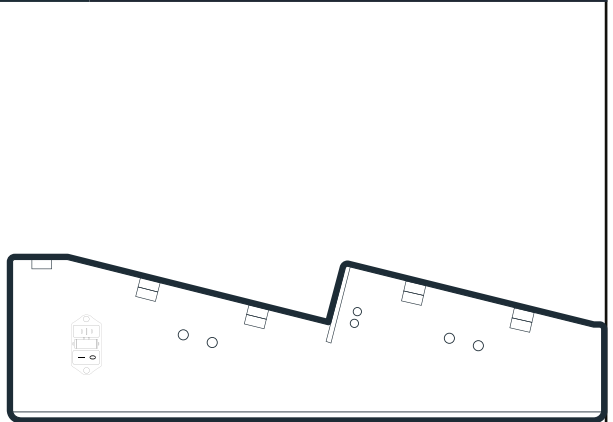

The charger station can be used in a horizontal position with the tags facing up.



Do not use the charger in a vertical position unless it is affixed to the wall

1a

1b

1c

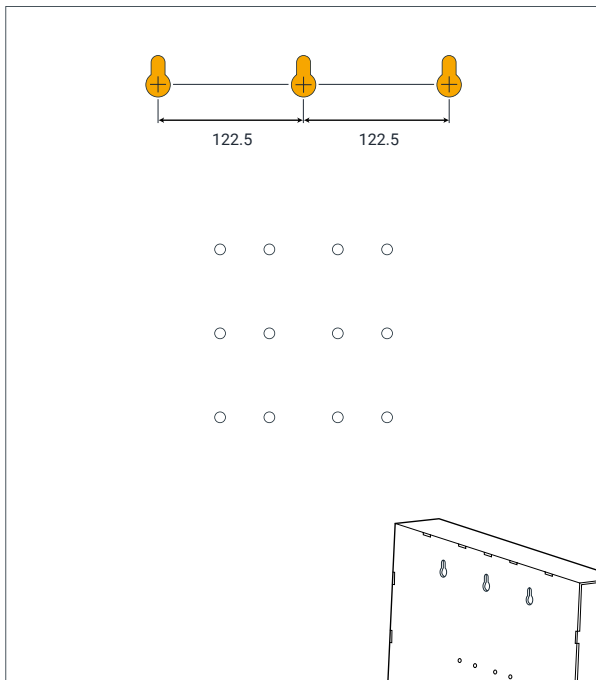

Charger Station Back View

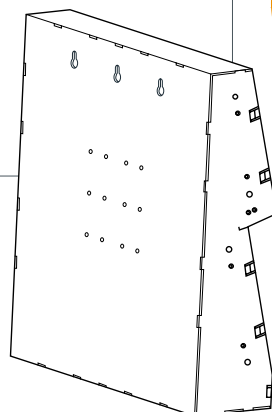

You can mount it by screwing through the holes numbered **1a/1b/1c**.

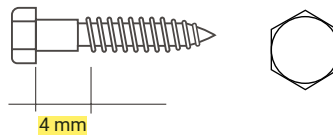

Excluding the screw head, 4mm should remain outside the wall. 8\*50 Trifon screw type can be used as reference.

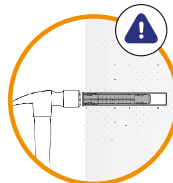

It is recommended to mount the charger station with 8x80 wall plug.

# Badge Tag Placement

# Charger Station

The Badge Tag must be inserted into the charging station slot as shown in the image below



# Compact Tag Holder Placement

# Charger Station

Insert the compact tag into the compact tag holder provided by Litum, then to the designated battery port to start charging.

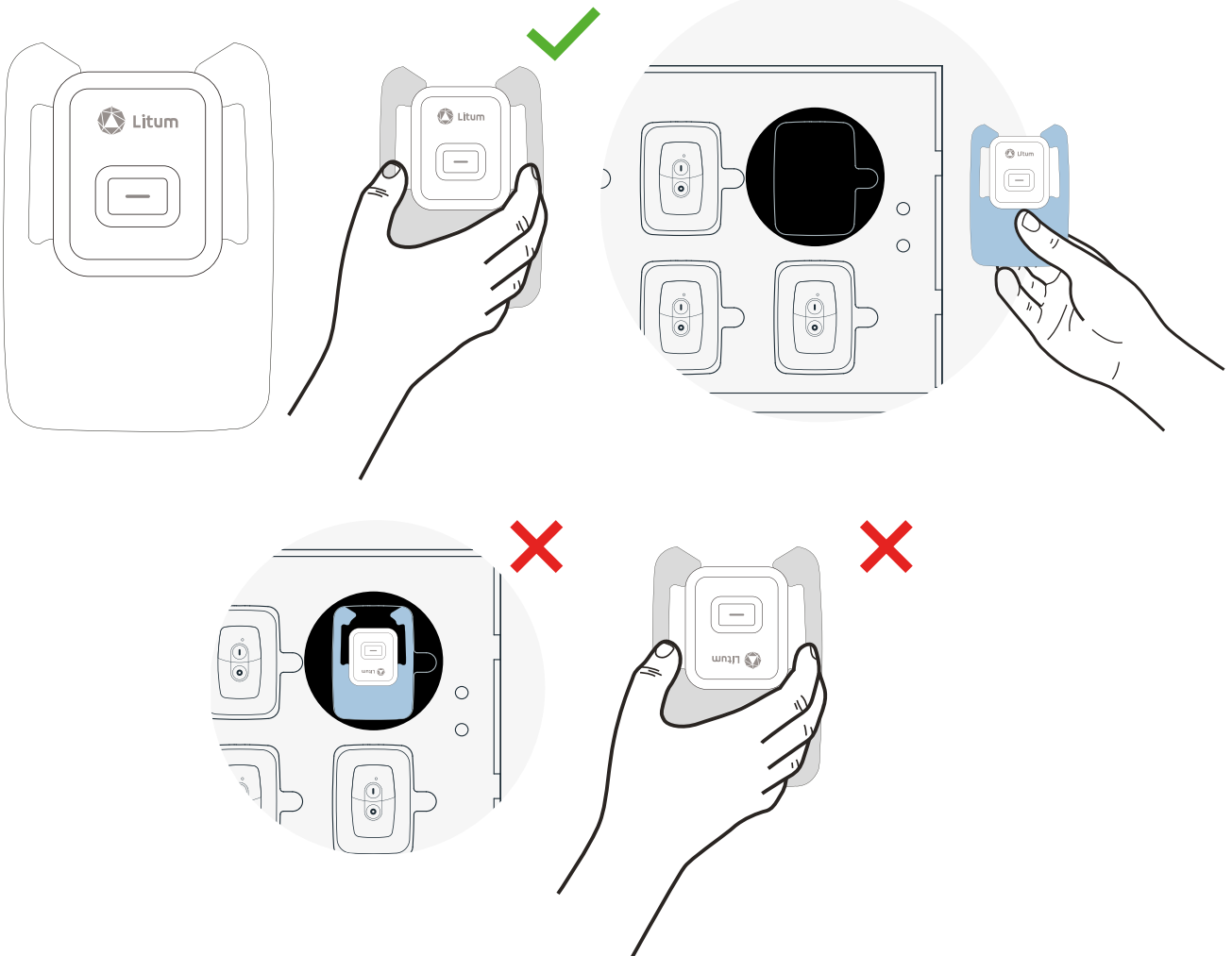

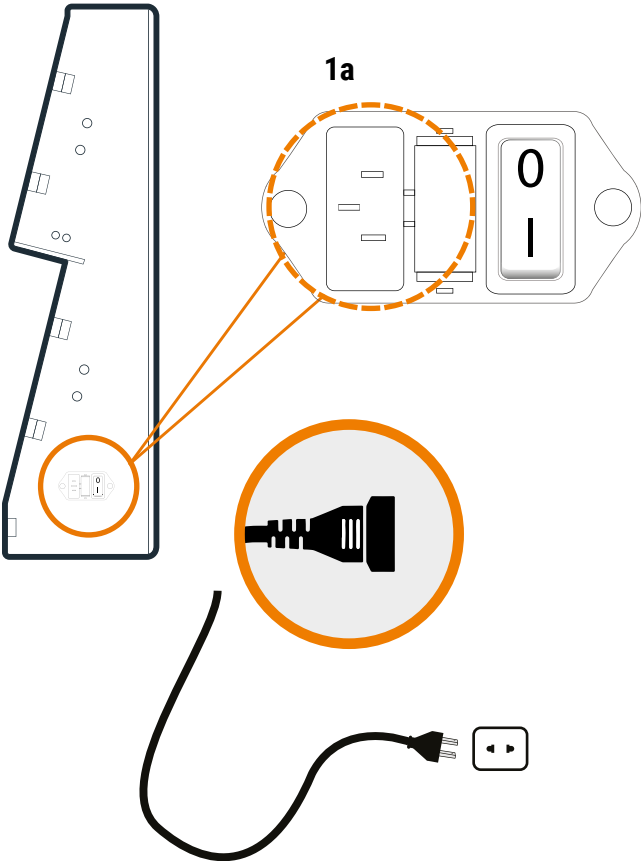

**1a** Connect the power cable to the device. Then plug the cable into the outlet. The charger station works in position I.

## Safety and Proper Handling

- Do not use deformed or damaged products.
- Do not modify the product.
- Protect the product from excessive moisture.
- Do not open the product lid.
- Do not use the product outside of the specified temperature values.
- Do not expose the product to strong magnetic fields.
- Do not cover the product with metal pieces.
- The equipment is not resistant against the immersion and splashes of water.
- Refrain from covering or concealing the charger station.

## Disposal & Recycling Information



**Dispose of the device according to the environmental regulations applicable in your country. Electrical waste must not be disposed of together with household waste. Bring the worn-out device to a collection center.**

## FCC Warning

This device complies with part 15 of the FCC Rules. Operation is subject to the following two conditions: (1) This device may not cause harmful interference, and (2) this device must accept any interference received, including interference that may cause undesired operation.

Any Changes or modifications not expressly approved by the party responsible for compliance could void the user's authority to operate the equipment.

**Note:** This equipment has been tested and found to comply with the limits for a Class B digital device, pursuant to part 15 of the FCC Rules. These limits are designed to provide reasonable protection against harmful interference in a residential installation. This equipment generates uses and can radiate radio frequency energy and, if not installed and used in accordance with the instructions, may cause harmful interference to radio communications. However, there is no guarantee that interference will not occur in a particular installation. If this equipment does cause harmful interference to radio or television reception, which can be determined by turning the equipment off and on, the user is encouraged to try to correct the interference by one or more of the following measures:

- Reorient or relocate the receiving antenna.
- Increase the separation between the equipment and receiver.
- Connect the equipment into an outlet on a circuit different from that to which the receiver is connected.
- Consult the dealer or an experienced radio/TV technician for help.

This equipment complies with FCC radiation exposure limits set forth for an uncontrolled environment. This equipment should be installed and operated with minimum distance 20cm between the radiator & your body.

## IC Warning

This device complies with Industry Canada's licence-exempt RSSs. Operation is subject to the following two conditions:

- (1) This device may not cause interference; and
- (2) This device must accept any interference, including interference that may cause undesired operation of the device.

This equipment complies with ISED radiation exposure limits set forth for an uncontrolled environment. This equipment should be installed and operated with minimum distance 10cm between the radiator & your body.

Cet appareil est conforme aux CNR exemptes de licence d'Industrie Canada . Son fonctionnement est soumis aux deux conditions suivantes :

- ( 1 ) Ce dispositif ne peut causer d'interférences ; et
- ( 2 ) Ce dispositif doit accepter toute interférence , y compris les interférences qui peuvent causer un mauvais fonctionnement de l'appareil.

Ce matériel est complé té par une exposition de rayonnements ISED pour un environnement naturel. Ce matériel doit être installé et se faire avec une distance minimale de 10cm entre les radiateurs et les autresYour body shop.