

Belun Technology Company Limited

TEST REPORT

SCOPE OF WORK:

47 CFR FCC Part 15.247 – Radio Spectrum report

Model:

BLR-100X

REPORT NUMBER

201200278TWN-001

ISSUE DATE

Mar. 19, 2021

PAGES

51

DOCUMENT CONTROL NUMBER

GFT-OP-10h (28-Nov-2018)

© 2020 Intertek



Radio Spectrum TEST REPORT

Applicant:	Belun Technology Company Limited Unit 218, 2/F, Core Building 2, No. 1 Science Park West Avenue, Hong Kong Science Park, Shatin, Hong Kong
Product:	Pulse oximeter
Model No.:	BLR-100X
FCC ID:	2AW6F-BLR100X
Test Method/ Standard:	47 CFR FCC Part 15.247 & ANSI C63.10 2013 KDB 558074 D01 v05r02
Test By:	Intertek Testing Services Taiwan Ltd., Hsinchu Laboratory No. 11, Lane 275, Ko-Nan 1 Street, Chia-Tung Li, Shiang-Shan District, Hsinchu City, Taiwan



Zero chen

Zero Chen
Engineer

Durant Wei

Durant Wei
Reviewer

This report is for the exclusive use of Intertek's Client and is provided pursuant to the agreement between Intertek and its Client. Intertek's responsibility and liability are limited to the terms and conditions of the agreement. Intertek assumes no liability to any party, other than to the Client in accordance with the agreement, for any loss, expense or damage occasioned by the use of this report. Only the Client is authorized to permit copying or distribution of this report and then only in its entirety. Any use of the Intertek name or one of its marks for the sale or advertisement of the tested material, product or service must first be approved in writing by Intertek. The observations and test results in this report are relevant only to the sample tested. This report by itself does not imply that the material, product, or service is or has ever been under an Intertek certification program.

TEST REPORT**Revision History**

Report No.	Issue Date	Revision Summary
201200278TWN-001	Mar. 19, 2021	Original report

Table of Contents

Summary of Test Data	5
1. General Information	6
1.1 Identification of the EUT	6
1.2 Antenna description	6
1.3 Operation mode	7
1.4 Peripherals equipment	8
2. Minimum 6 dB Bandwidth	9
2.1 Instrument Setting.....	9
2.2 Test Procedure	9
2.3 Test Diagram	9
2.4 Limit.....	9
2.5 Test Results	10
3. Maximum Peak Conducted Output Power	14
3.1 Instrument Setting.....	14
3.2 Test Procedure	14
3.3 Test Diagram	14
3.4 Limit.....	14
3.5 Test Results	15
4. Power Spectral Density.....	16
4.1 Instrument Setting.....	16
4.2 Test Procedure	16
4.3 Test Diagram	16
4.4 Limit.....	16
4.5 Test Results	17
5. Emissions in Non-Restricted Frequency Bands	21
5.1 Instruments Setting	21
5.2 Test Procedure	21
5.3 Test Diagram	21
5.4 Limit.....	21
5.5 Test Results	21
6. Emissions in Restricted Frequency Bands (Radiated emission measurements)	29
6.1 Instrument Setting.....	29
6.2 Test Procedure	29
6.3 Test Diagram	30
6.3.1 Radiated emission from 9kHz to 30MHz uses Loop Antenna:	30
6.3.2 Radiated emission below 1GHz using Bilog Antenna	30
6.3.3 Radiated emission above 1GHz using Horn Antenna	31
6.4 Limit.....	31

TEST REPORT

6.5 Test Result..... 32

7. Emission on Band Edge..... 39

 7.1 Instrument Setting..... 39

 7.2 Test Procedure 39

 7.3 Test Results 39

8. AC Power Line Conducted Emission 45

 8.1 Measuring instrument setting..... 45

 8.2 Test Procedure 45

 8.3 Test Diagram 45

 8.4 Limit..... 46

 8.5 Test Results 47

Appendix A: Test equipment list..... 49

Appendix B: Measurement Uncertainty..... 51

Summary of Test Data

Test Requirement	Applicable Rule (Section 15.247)	Result
Minimum 6 dB Bandwidth	15.247(a)(2)	Pass
Maximum Peak Conducted Output Power	15.247(b)(3)	Pass
Power Spectral Density	15.247(e)	Pass
Emissions In Non-Restricted Frequency Bands	15.247(d)	Pass
Emissions In Restricted Frequency Bands (Radiated emission measurements)	15.247(d), 15.205, 15.209	Pass
Emission On The Band Edge	15.247(d), 15.205	Pass
AC Power Line Conducted Emission	15.207	Pass
Antenna Requirement	15.203	Pass

Note: Please note that the test results with statement of conformity, the decision rules which are based on: Safety Testing: the specification, standard or IEC Guide 115.

Other Testing: the specification, standard and not taking into account the measurement uncertainty.

1. General Information**1.1 Identification of the EUT**

Product:	Pulse oximeter
Model No.:	BLR-100X
Operating Frequency:	2402 MHz ~ 2480 MHz
Channel Number:	40 channels
Frequency of Each Channel:	2402+2 k, k=0 ~ 39
Rated Power:	DC 5V
Power Cord:	N/A
Sample receiving date:	2020/12/21
Sample condition:	Workable
Test Date(s):	2021/01/20 ~ 2021/02/08

1.2 Antenna description

Antenna Gain : 3.3 dBi
Antenna Type : PCB antenna
Connector Type : Fixed

1.3 Operation mode

Connected to Notebook via USB to TTL Converter Cable, open "nRF Connect v3.6" and select different frequency and modulation.

Mode	Channel	Frequency (MHz)	Signal on time (ms)	Signal on & off time (ms)	Duty cycle	Duty Cycle factor	1/T Minimum VBW (kHz)
BLE 1M	19	2440	0.104	0.626	16.61%	7.80	9.62
BLE 2M	19	2440	0.061	0.626	9.74%	10.11	16.39

Duty Cycle @ BLE 1M Mode Ch 19

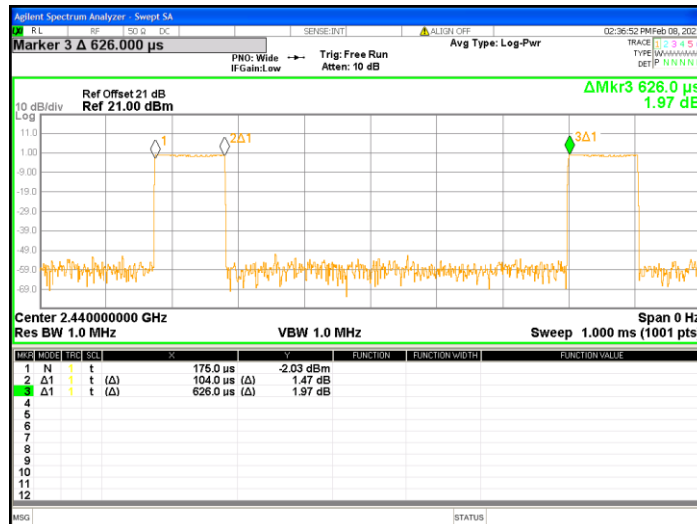

Duty Cycle @ BLE 2M Mode Ch 19

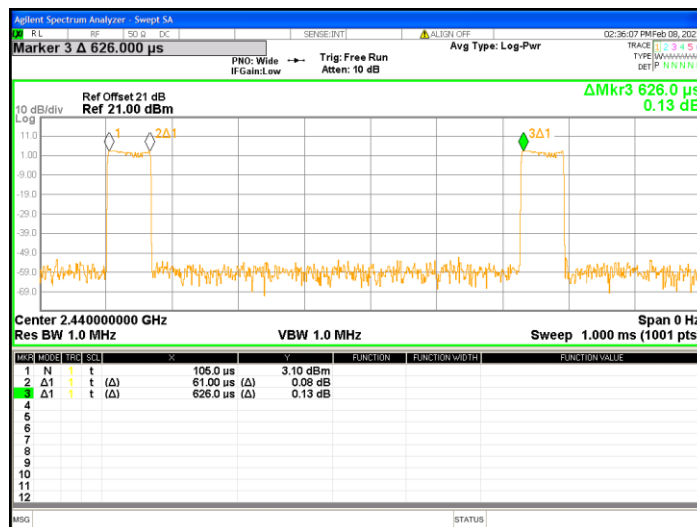

1.4 Peripherals equipment

Peripherals	Brand	Model No.	Serial No.	Data cable
Notebook PC (By client)	Lenovo	80TV	PFORXGZZ	USB to TTL Converter Cable 1 meter × 1
Fixture (By client)	CP2102	MODULES	HW-598	N/A
Adapter	CARKOCI	DLH-8488AC	N/A	USB Type-C Cable 1 meter × 1
Notebook PC	HP	N15Q3	N/A	USB Type-C Cable 1 meter × 1
Swivel Hub	belkin	N10117	N/A	N/A
Modem	LEMEL	MD-56KVT-100	3872B339	N/A
Mouse	HP	MOHQQUO	N/A	N/A

2. Minimum 6 dB Bandwidth

2.1 Instrument Setting

Spectrum Parameter	Setting
Detector	Peak
RBW	100kHz
VBW	$\geq 3 \times \text{RBW}$
Sweep	Auto couple
Trace	Allow the trace to stabilize.
Span	Between two times and five times the occupied bandwidth
Attenuation	Auto

2.2 Test Procedure

Step 1	The transmitter output was connected to the spectrum analyzer.
Step 2	Test was performed accordance with ANSI C63.10.
Step 3	Measure the maximum width of the emission that is constrained by the frequencies associated with the two outermost amplitude points (upper and lower frequencies) that are attenuated by 6 dB relative to the maximum level measured in the fundamental emission

2.3 Test Diagram

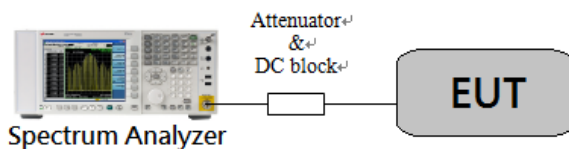

2.4 Limit

The minimum 6 dB bandwidth shall be at least 500 kHz.

TEST REPORT**2.5 Test Results**

Temperature (°C) :	22
Relative Humidity (%) :	57
Test date :	2021/1/20

Mode	Channel	Frequency (MHz)	6dB Bandwidth (MHz)	Limit (MHz)	Result
BLE 1M	0	2402	0.686	>0.5	Pass
	19	2440	0.686	>0.5	Pass
	39	2480	0.686	>0.5	Pass

6dB Bandwidth @ BLE 1M Ch 0

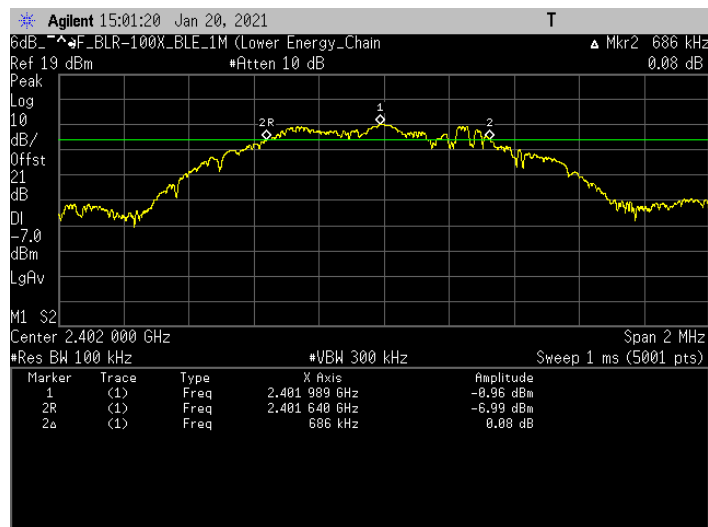

6dB Bandwidth @ BLE 1M Ch 19

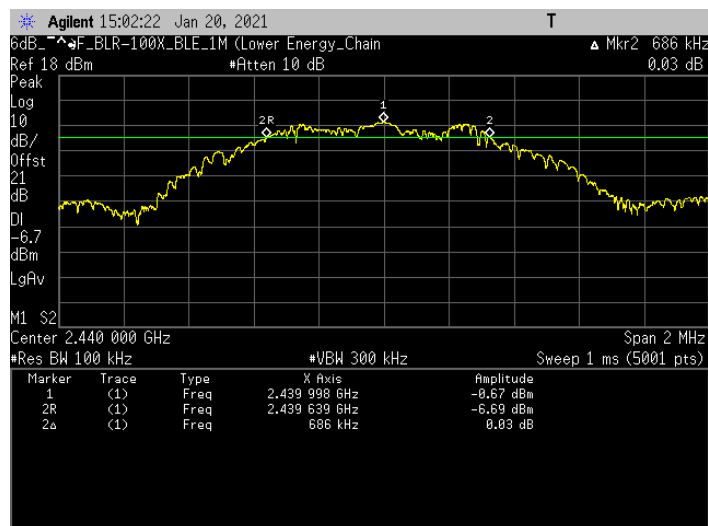

6dB Bandwidth @ BLE 1M Ch 39

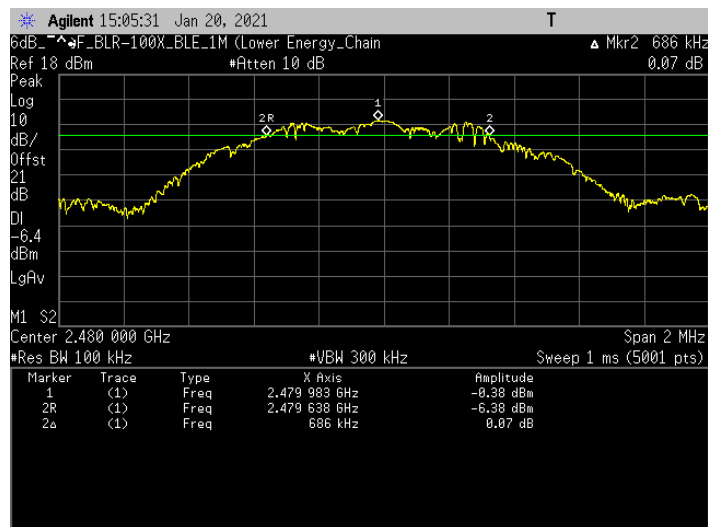

TEST REPORT

Temperature (°C) :	24
Relative Humidity (%) :	61
Test date :	2021/2/8

Mode	Channel	Frequency (MHz)	6dB Bandwidth (MHz)	Limit (MHz)	Result
BLE 2M	0	2402	1.179	>0.5	Pass
	19	2440	1.154	>0.5	Pass
	39	2480	1.155	>0.5	Pass

6dB Bandwidth @ BLE 2M Ch 0

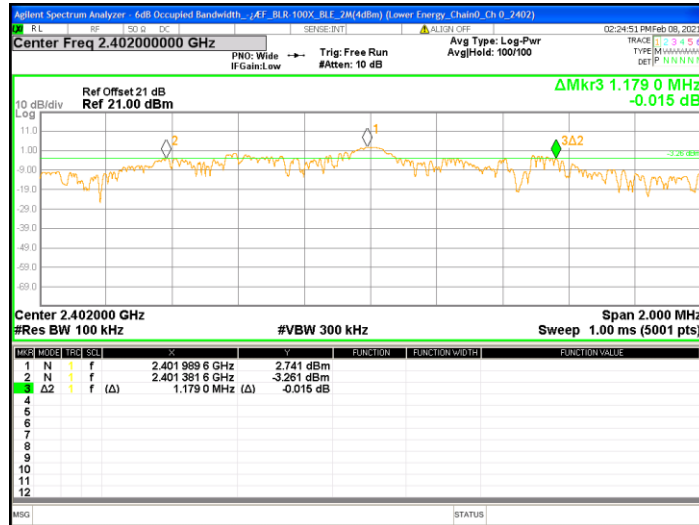

6dB Bandwidth @ BLE 2M Ch 19

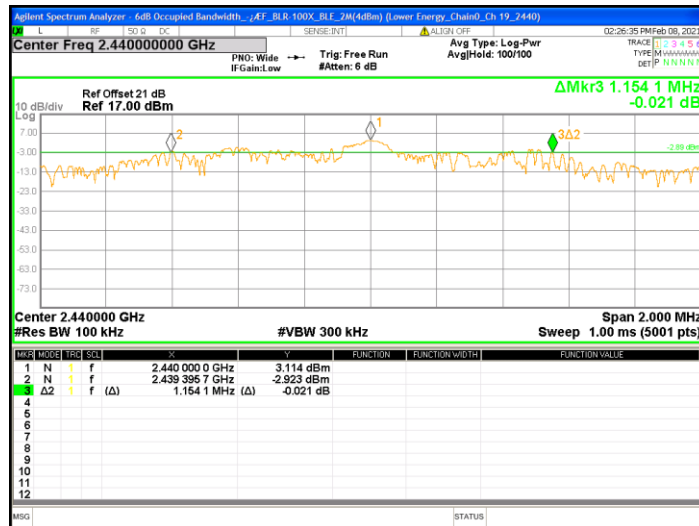

6dB Bandwidth @ BLE 2M Ch 39

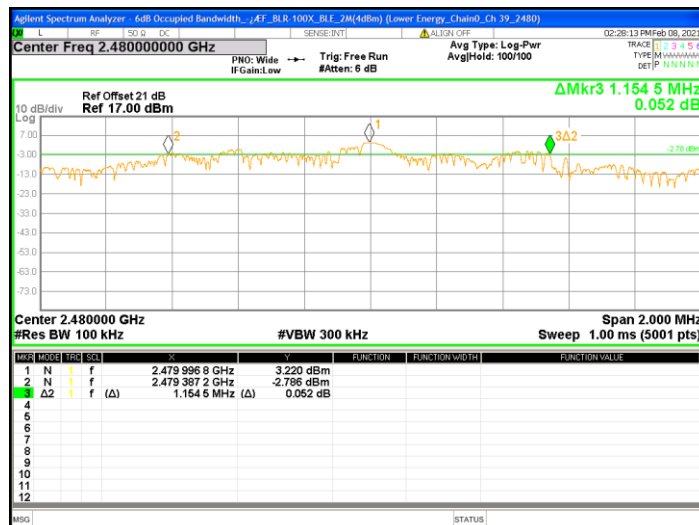

3. Maximum Peak Conducted Output Power

3.1 Instrument Setting

Power Meter Parameter	Setting
Bandwidth	65MHz bandwidth is greater than the EUT emission bandwidth
Detector	Peak & Average

3.2 Test Procedure

The preferred methodology is to use integrated average power measurements, as described in 11.9.2 and 11.13.3 of ANSI C63.10. The peak integrated band power methods of 11.9.1.2 and 11.13.3.2 of ANSI C63.10 are not applicable for FCC compliance testing purposes.

3.3 Test Diagram

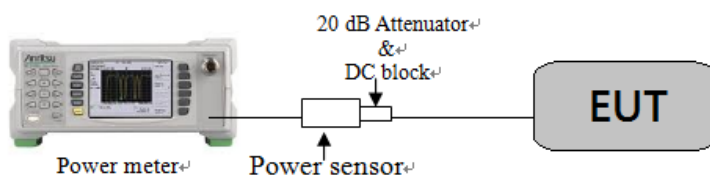

3.4 Limit

For systems using digital modulation in the 2400-2483.5 MHz: 1 Watt (30dBm)

TEST REPORT

3.5 Test Results

Temperature (°C) :	22
Relative Humidity (%) :	57
Test date :	2021/1/20

Mode	Channel	Frequency (MHz)	Output Power (AV) (dBm)	Total Power (AV) (mW)	Maximum power (PK) (dBm)	Maximum power (PK) (mW)	Limit (dBm)	Margin (dB)
BLE 1M	0	2402	-0.34	0.92	1.33	1.36	30	-28.67
	19	2440	0.07	1.02	1.69	1.48	30	-28.31
	39	2480	0.22	1.05	1.47	1.40	30	-28.53

Temperature (°C) :	24
Relative Humidity (%) :	61
Test date :	2021/2/8

Mode	Channel	Frequency (MHz)	Output Power (AV) (dBm)	Total Power (AV) (mW)	Maximum power (PK) (dBm)	Maximum power (PK) (mW)	Limit (dBm)	Margin (dB)
BLE 2M	0	2402	2.96	1.98	3.80	2.40	30	-26.20
	19	2440	3.14	2.06	3.83	2.42	30	-26.17
	39	2480	3.28	2.13	4.00	2.51	30	-26.00

4. Power Spectral Density

4.1 Instrument Setting

Spectrum Function	Setting
Detector	Peak
RBW	≥ 3 kHz
VBW	≥ 3 x RBW
Sweep	Auto couple
Trace	Max hold
Span	1.5 times x 6dB bandwidth
Attenuation	Auto

4.2 Test Procedure

Step 1	Test procedure refer to subclause 11.10 of ANSI C63.10.
Step 2	Using the maximum conducted output power in the fundamental emission demonstrates compliance. The EUT must be configured to transmit continuously at full power over the measurement duration.
Step 3	Use the peak marker function to determine the maximum amplitude level within the RBW.

4.3 Test Diagram

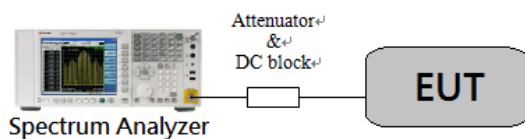

4.4 Limit

For digitally modulated systems, the power spectral density conducted from the intentional radiator to the antenna shall not be greater than 8 dBm in any 3 kHz band during any time interval of continuous transmission

TEST REPORT

4.5 Test Results

Temperature (°C) :	22
Relative Humidity (%) :	57
Test date :	2021/1/20

Mode	Channel	Frequency (MHz)	RBW factor	PSD in 10kHz	PSD in 3kHz		Limit (dBm)	Margin (dB)
					(dBm)	(mW)		
BLE 1M	0	2402	5.23	-18.42	-23.65	0.00	8	-31.65
	19	2440	5.23	-19.00	-24.23	0.00	8	-32.23
	39	2480	5.23	-18.28	-23.51	0.00	8	-31.51

Correction (RBW) Factor in 3kHz = $10\log(10\text{kHz}/3\text{kHz}) = 5.23$

Power Spectral Density @ BLE 1M Ch 0

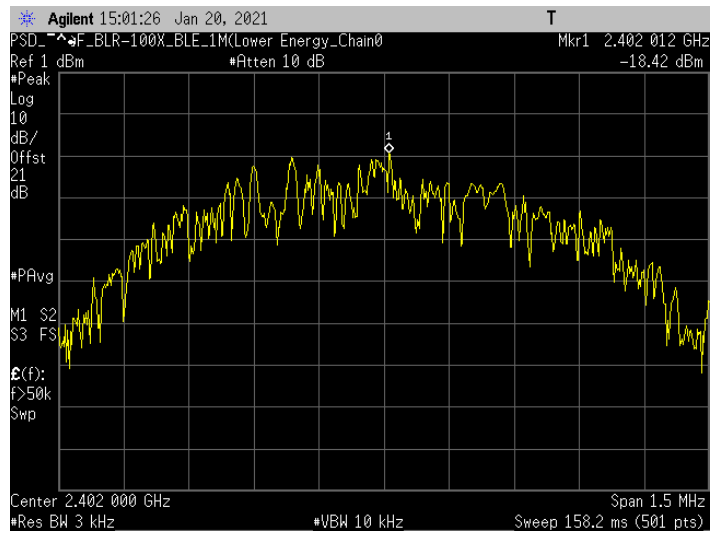

Power Spectral Density @ BLE 1M Ch 19

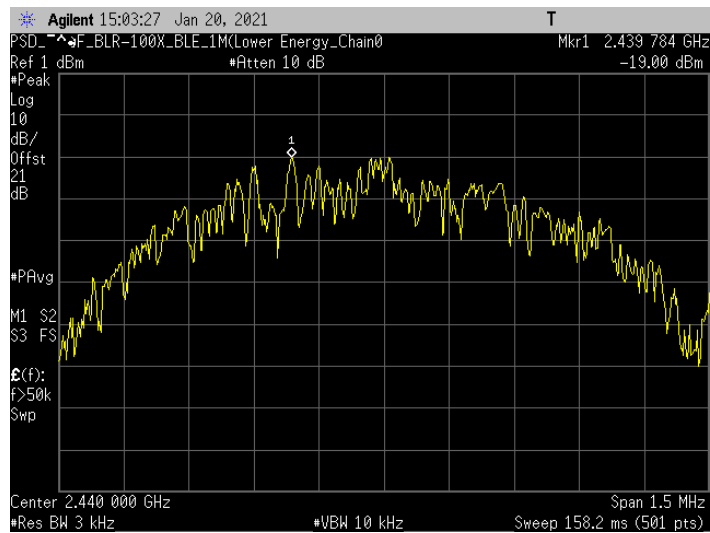

Power Spectral Density @ BLE 1M Ch 39

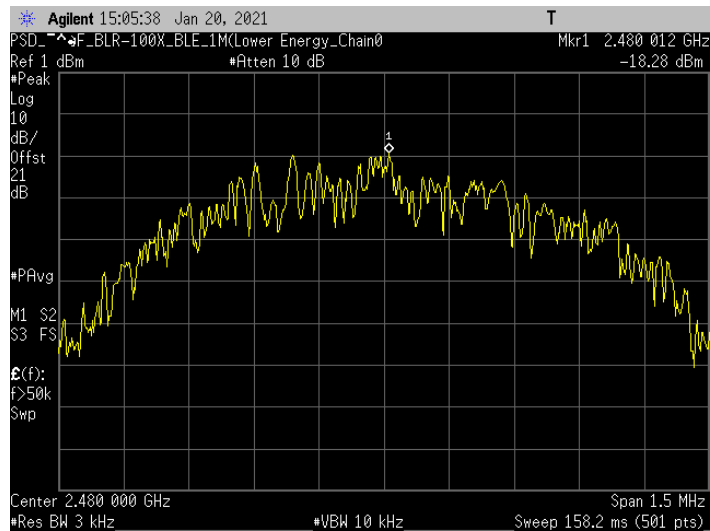

TEST REPORT

Temperature (°C) :	24
Relative Humidity (%) :	61
Test date :	2021/2/8

Mode	Channel	Frequency (MHz)	RBW factor	PSD in 10kHz	PSD in 3kHz		Limit (dBm)	Margin (dB)
					(dBm)	(mW)		
BLE 2M	0	2402	5.23	-7.23	-12.46	0.06	8	-20.46
	19	2440	5.23	-7.06	-12.29	0.06	8	-20.29
	39	2480	5.23	-7.07	-12.30	0.06	8	-20.30

Correction (RBW) Factor in 3kHz = $10\log(10\text{kHz}/3\text{kHz}) = 5.23$

Power Spectral Density @ BLE 2M Ch 0



Power Spectral Density @ BLE 2M Ch 19

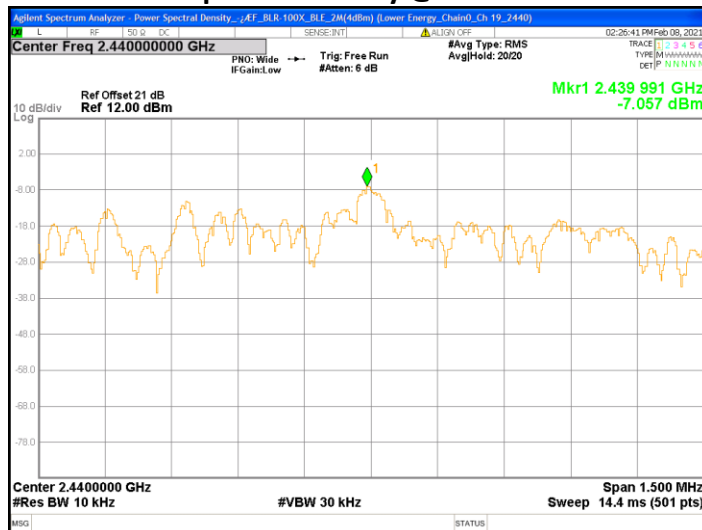

Power Spectral Density @ BLE 2M Ch 39



5. Emissions in Non-Restricted Frequency Bands

5.1 Instruments Setting

Spectrum Function	Setting (Reference Level)	Setting (Emission Level)
Detector	Peak	Peak
RBW	≥ 100 kHz	≥ 100 kHz
VBW	$\geq 3 \times$ RBW	$\geq 3 \times$ RBW
Sweep	Auto couple	Auto couple
Trace	Max hold	Max hold
Span	≥ 1.5 time 6dB bandwidth	X
Attenuation	Auto	Auto

5.2 Test Procedure

- Step 1 The procedure was used in antenna-port conducted and connected to the spectrum analyzer.
- Step 2 Set instrument center frequency to center frequency.
- Step 3 Use the parameter configured in subclause 11.11 of ANSI C63.10 to measure.
- Step 4 Use the peak marker function to determine the maximum amplitude level.

5.3 Test Diagram

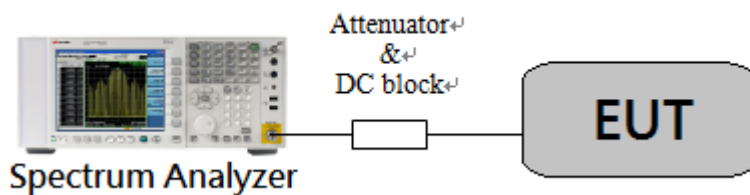

5.4 Limit

The peak output power measured in any 100 kHz bandwidth outside of the authorized frequency band shall be attenuated by at least 20 dB relative to the maximum in-band peak PSD level in 100 kHz

5.5 Test Results

Temperature (°C) :	22
Relative Humidity (%) :	57
Test date :	2021/1/20

Conducted Spurious @ BLE 1M Mode Ch 0

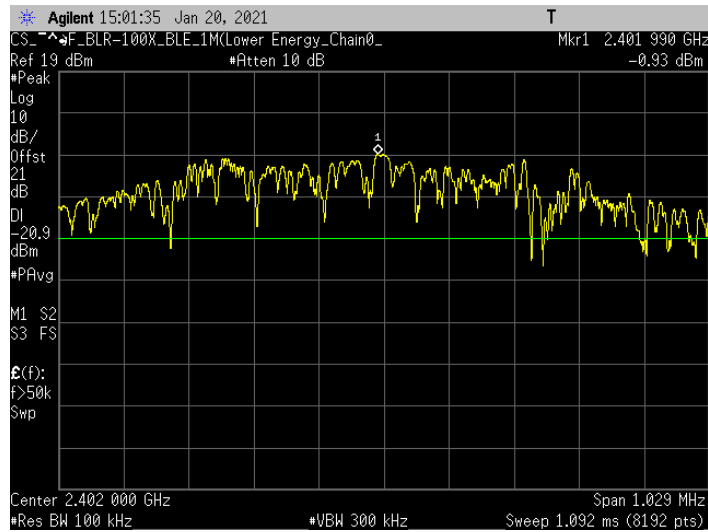

Conducted Spurious @ BLE 1M Mode Ch 0

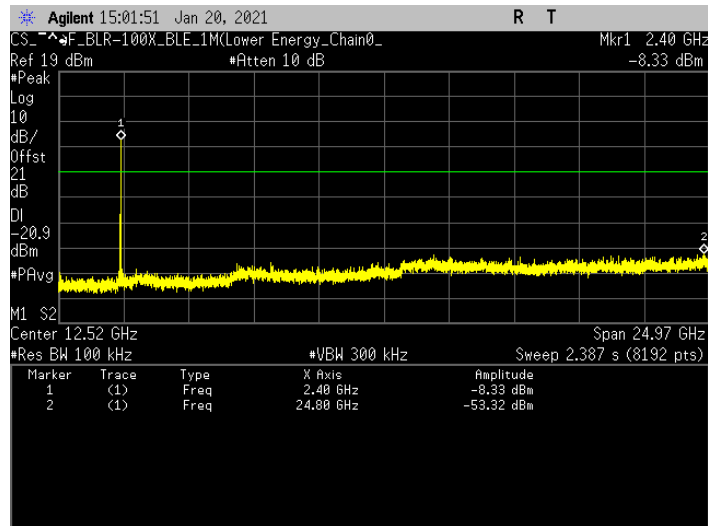

Conducted Spurious @ BLE 1M Mode Ch 19

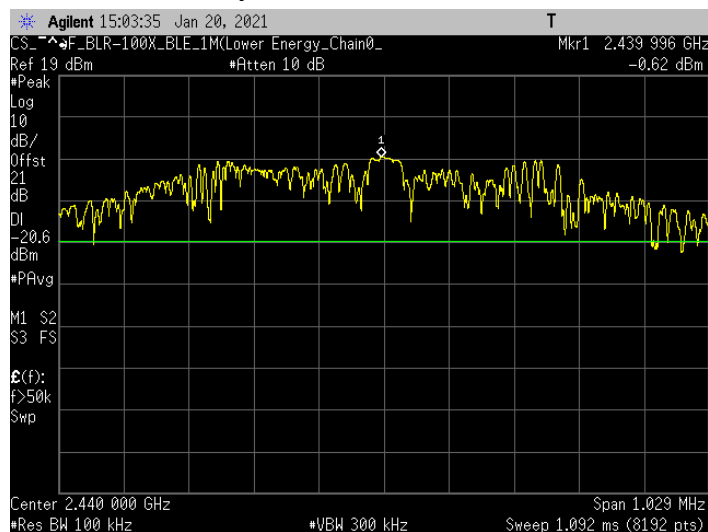

Conducted Spurious @ BLE 1M Mode Ch 19

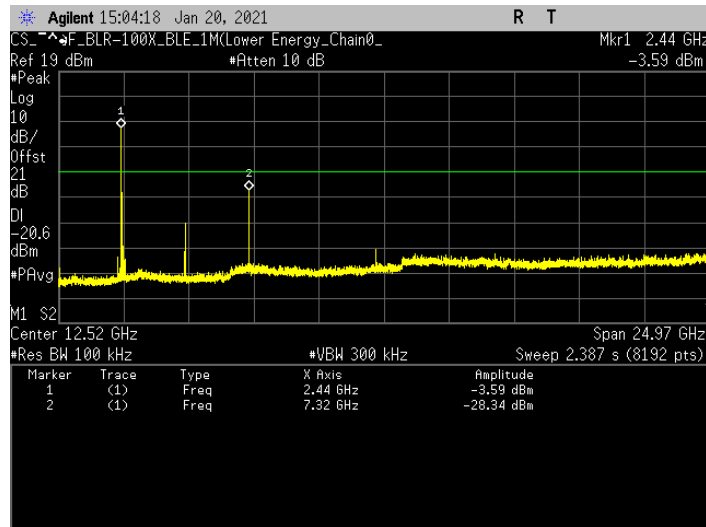

Conducted Spurious @ BLE 1M Mode Ch 39

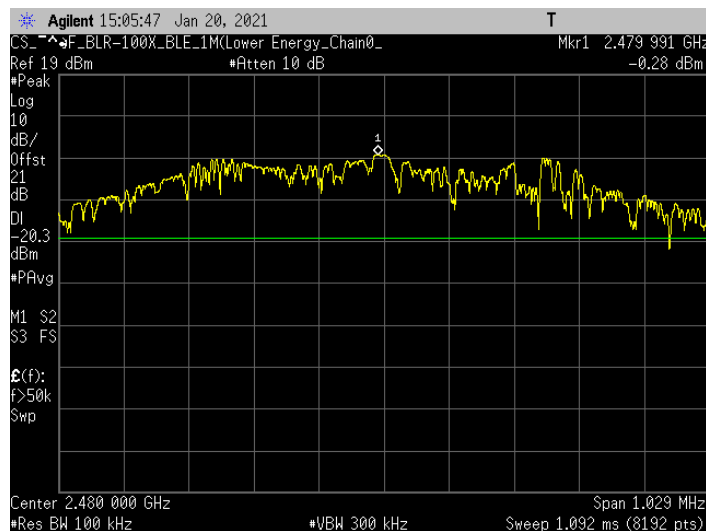

Conducted Spurious @ BLE 1M Mode Ch 39

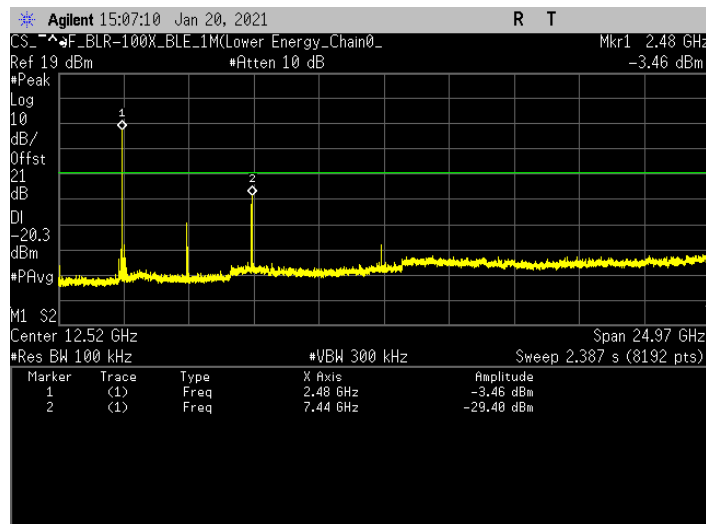

Temperature (°C) :	23
Relative Humidity (%) :	58
Test date :	2021/2/2

Authorized Band Bandedge @ BLE 1M Mode Ch0

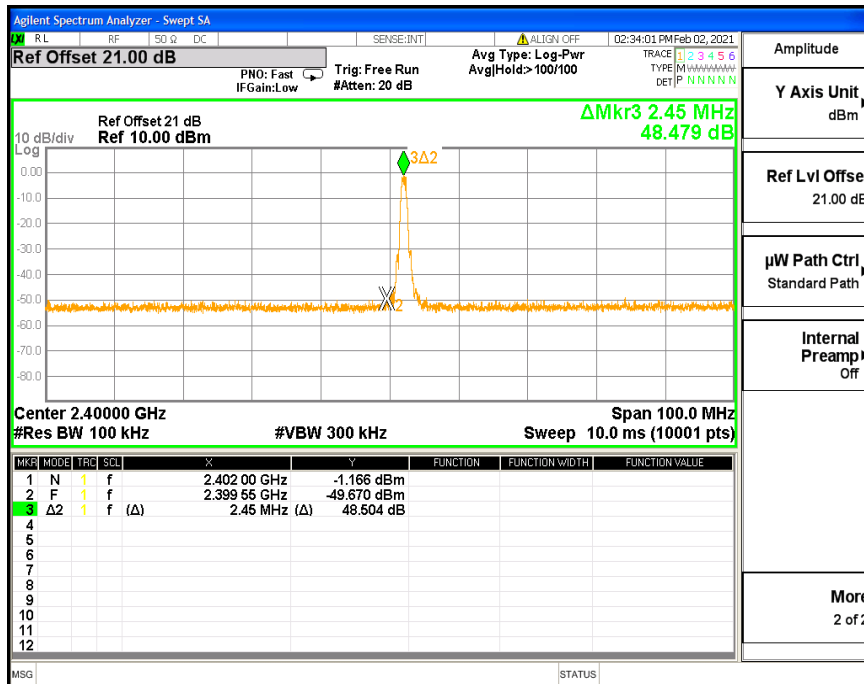

Authorized Band Bandedge @ BLE 1M Mode Ch39

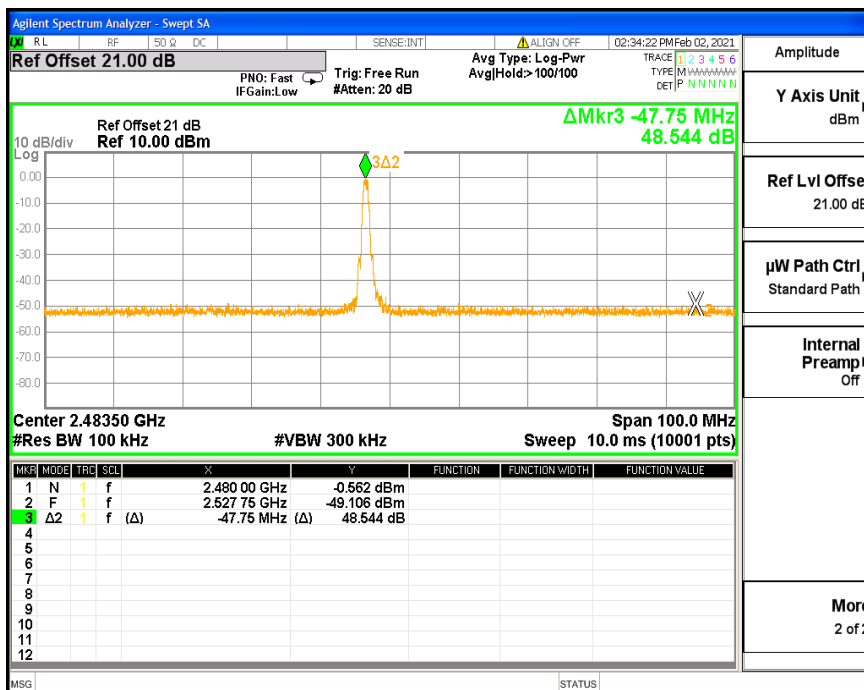

Temperature (°C) :	24
Relative Humidity (%) :	61
Test date :	2021/2/08

Conducted Spurious @ BLE 2M Mode Ch 0

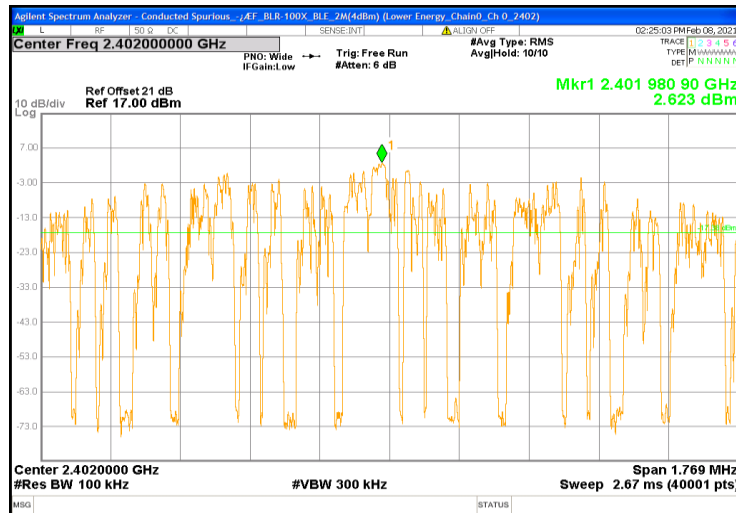

Conducted Spurious @ BLE 2M Mode Ch 0

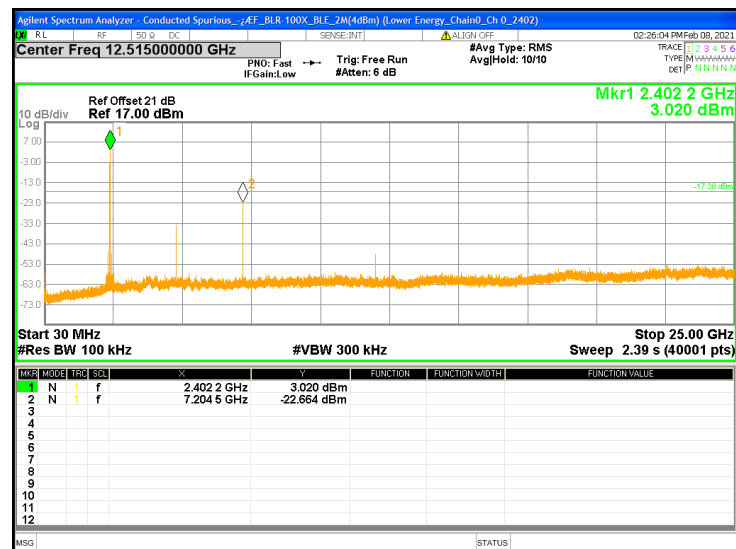

Conducted Spurious @ BLE 2M Mode Ch 19

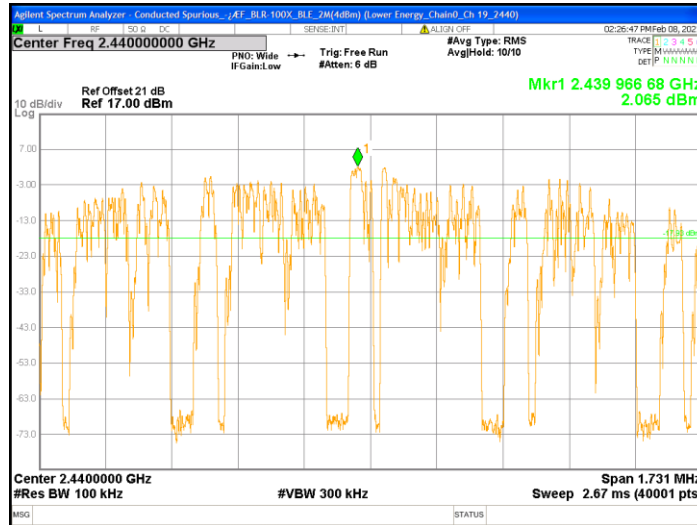

Conducted Spurious @ BLE 2M Mode Ch 19

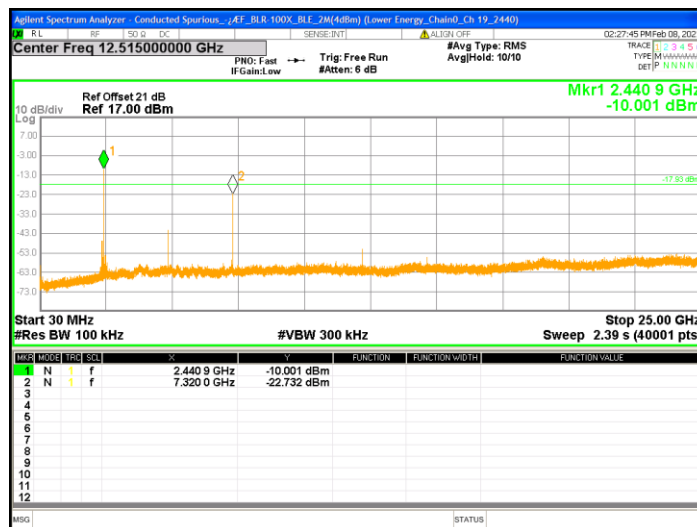

Conducted Spurious @ BLE 2M Mode Ch 39

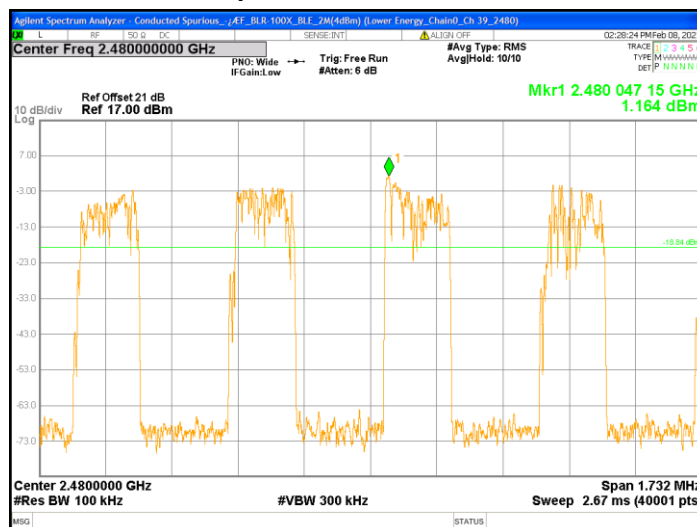

Conducted Spurious @ BLE 2M Mode Ch 39

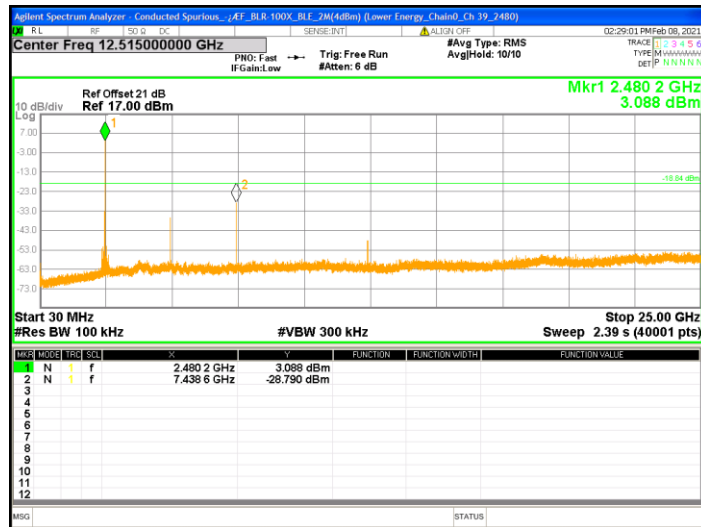

Temperature (°C) :	23
Relative Humidity (%) :	58
Test date :	2021/2/02

Authorized Band Bandedge @ BLE 2M Mode Ch0

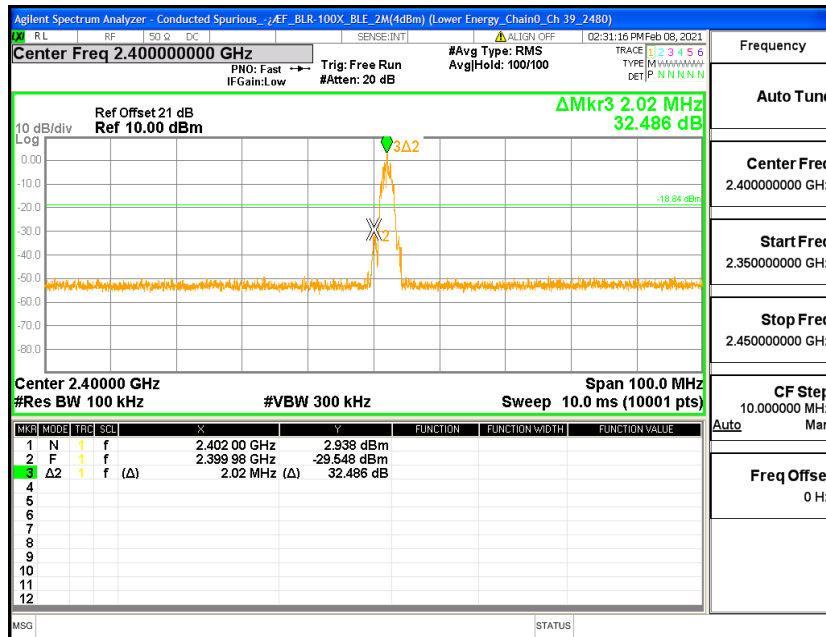

Authorized Band Bandedge @ BLE 2M Mode Ch39

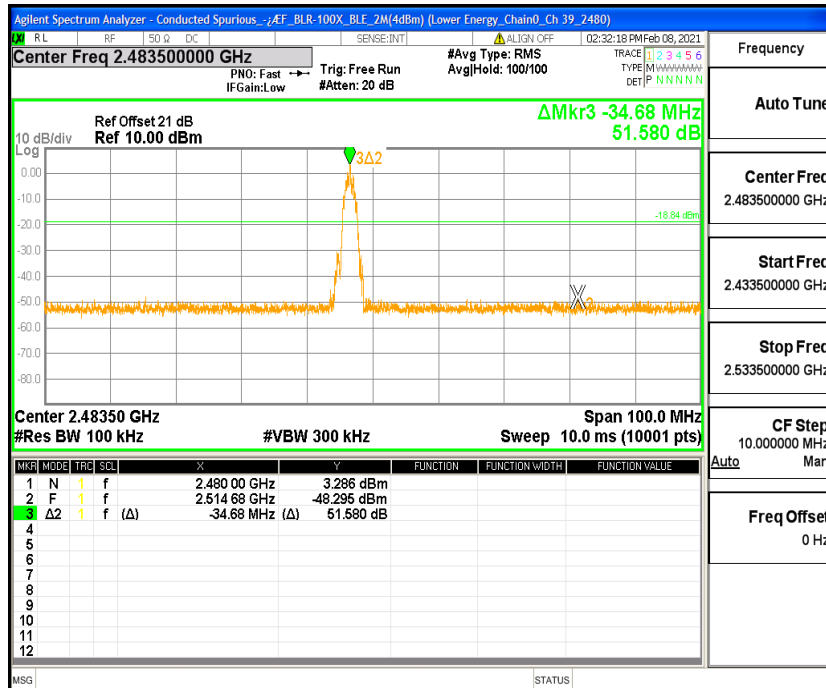

TEST REPORT

6. Emissions in Restricted Frequency Bands (Radiated emission measurements)

6.1 Instrument Setting

Receiver Function	Setting (Below 1GHz)	Setting (Above 1GHz)
Detector	QP	Peak and Average
RBW	9-150 kHz ; 200-300 Hz 0.15-30 MHz; 9-10 kHz 30-1000 MHz; 100-120 kHz	1MHz
VBW	$\geq 3 \times \text{RBW}$	3MHz & 1/T Minimum VBW
Sweep	Auto couple	Auto couple
Start Frequency	9 kHz	1GHz
Stop Frequency	1 GHz	Tenth harmonic
Attenuation	Auto	Auto

6.2 Test Procedure

Step 1	Configure the EUT according to ANSI C63.10:2013. The EUT was placed on the top of the turntable 0.8 meter (below 1GHz) and 1.5 meter (above 1GHz) above ground. The center of the receiving antenna mounted on the top of a height-variable antenna tower was placed 3 meters far away from the turntable.
Step 2	Power on the EUT and all the companion devices. The turntable was rotated by 360 degree to find the position of the maximum emission level.
Step 3	The height of the receiving antenna was varied between one meter and four meters above ground to find the maximum emission field strength of the both horizontal and vertical polarization.
Step 4	If find the frequencies above the limit or below within 3dB, the antenna tower was scan (from 1m to 4m) and then the turntable was rotated to find the maximum reading.
Step 5	Set the test-receiver system to peak or CISPR quasi-peak detector with specified bandwidth under maximum hold mode.
Step 6	For emissions above 1GHz, use 1MHz VBW and 3MHz RBW for reading in spectrum analyzer. Place the measurement antenna away from each area of the EUT determined to be a source of emissions at the specified measurement distance, while keeping the measurement antenna aimed at the source of emissions at each frequency of significant emissions, with polarization oriented for maximum response.
Step 7	If the emissions level of the EUT in peak mode was 3dB lower than the average limit specified then testing will be stopped and peak values of the EUT will be reported. Otherwise, the emissions which do not have 3dB margin will be measured using the quasi-peak method for below 1GHz.
Step 8	For testing above 1GHz, The emissions level of the EUT in peak mode was lower than average limit, then testing will be stopped and peak values of the EUT will be reported, otherwise, the emission will be measured in average mode again and reported.
Step 9	In case the emission is lower than 30MHz, loop antenna has to be used for measurement and the recorded data should be quasi-peak measured by receiver.

6.3 Test Diagram

6.3.1 Radiated emission from 9kHz to 30MHz uses Loop Antenna:

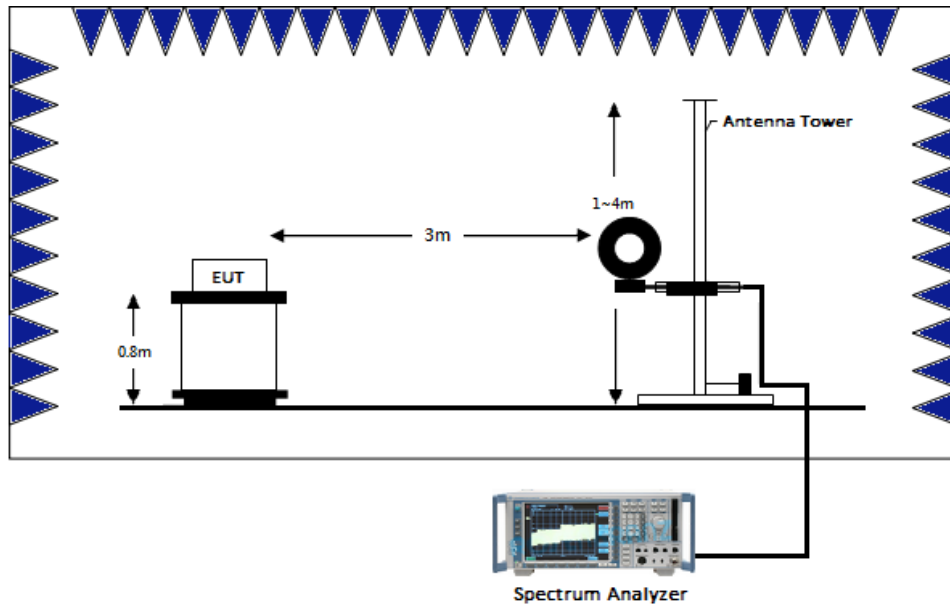

6.3.2 Radiated emission below 1GHz using Bilog Antenna

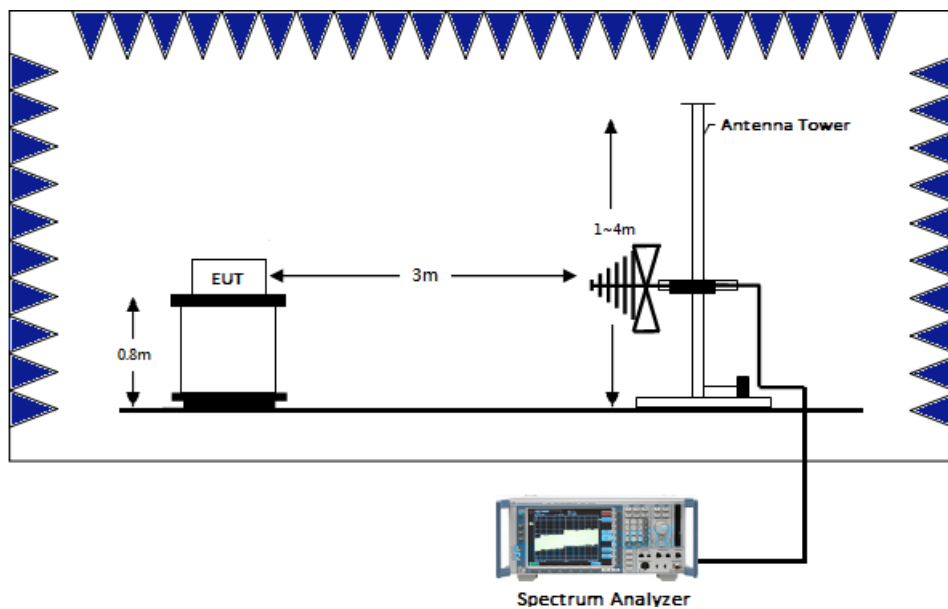

6.3.3 Radiated emission above 1GHz using Horn Antenna

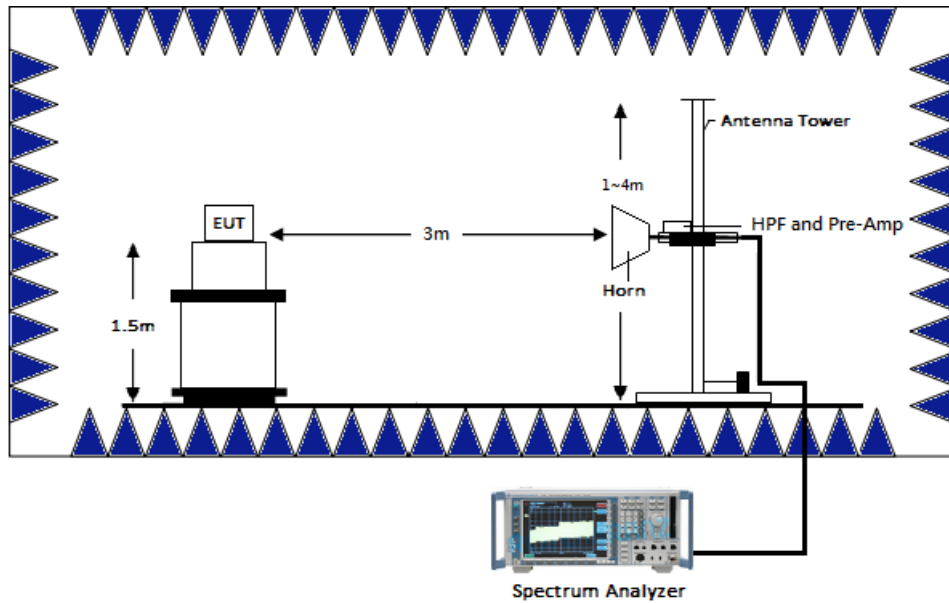

6.4 Limit

Frequency(MHz)	Field Strength(uV/m)	Measurement distance(m)
0.009~0.490	2400/F(kHz)	300
0.490~1.705	24000/F(kHz)	30
1.705~30	30	30
30-88	100	3
88-216	150	3
216-960	200	3
Above 960	500	3

Remark:

1. In the above table, the tighter limit applies at the band edges.
2. Distance refers to the distance in meters between the measuring instrument antenna and the closed point of any part of the device or system

TEST REPORT

6.5 Test Result

6.5.1 Measurement results: frequencies 9kHz to 30MHz

Temperature (°C) :	24
Relative Humidity (%) :	65
Test date :	2021/2/1

The test was performed on EUT under continuously transmitting mode. The worst case occurred at BLE 2M Channel 39.

Antenna Polarity	Frequency (MHz)	Spectrum Analyzer Detector	Correction Factor (dB/m)	Reading (dBμV)	Corrected Reading (dBμV/m)	Limit @ 3 m (dBμV/m)	Margin (dB)
Perpendicular	0.07	AV	18.37	53.36	71.73	110.70	-38.97
Perpendicular	0.13	AV	17.92	52.96	70.88	105.33	-34.45
Perpendicular	0.19	AV	18.13	51.07	69.20	102.03	-32.83
Perpendicular	0.31	AV	18.53	42.94	61.47	97.78	-36.31
Perpendicular	0.43	AV	18.47	38.03	56.50	94.93	-38.43
Perpendicular	0.73	QP	18.45	28.21	46.66	70.34	-23.68

Remark: Corr. Factor = Antenna Factor + Cable Loss

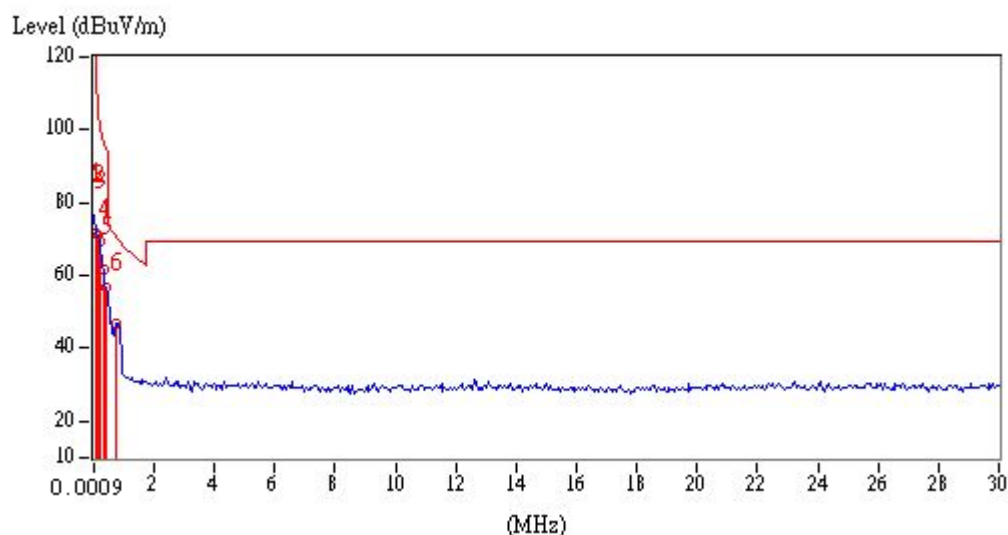

TEST REPORT

Antenna Polarity	Frequency (MHz)	Spectrum Analyzer Detector	Correction Factor (dB/m)	Reading (dB μ V)	Corrected Reading (dB μ V/m)	Limit @ 3 m (dB μ V/m)	Margin (dB)
Parallel	0.07	AV	18.37	54.53	72.90	110.70	-37.80
Parallel	0.13	AV	17.92	53.50	71.42	105.33	-33.91
Parallel	0.19	AV	18.13	50.53	68.66	102.03	-33.37
Parallel	0.31	AV	18.53	43.05	61.58	97.78	-36.20
Parallel	0.49	AV	18.44	33.85	52.29	93.80	-41.51
Parallel	0.79	QP	18.46	29.35	47.81	69.65	-21.84

Remark: Corr. Factor = Antenna Factor + Cable Loss

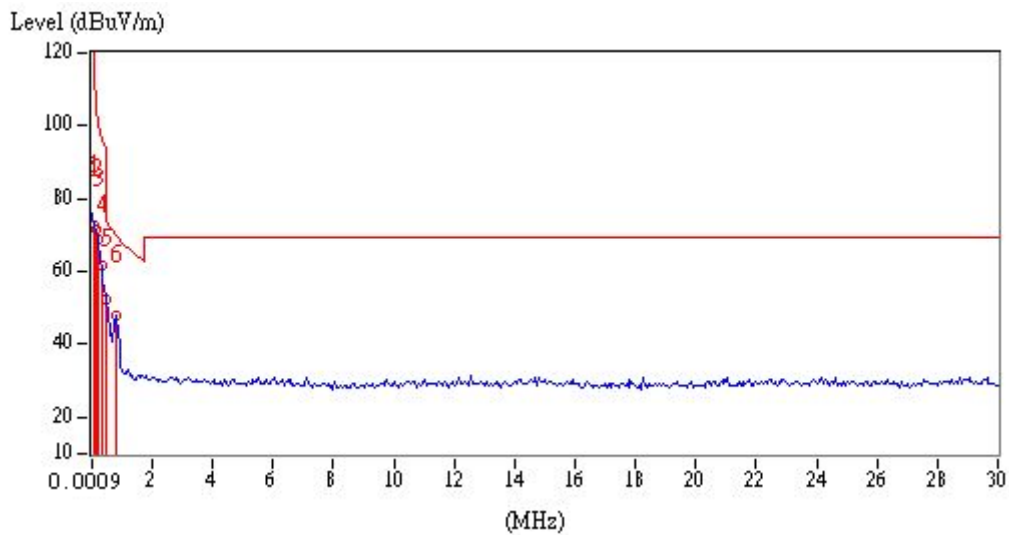

TEST REPORT

Antenna Polarity	Frequency (MHz)	Spectrum Analyzer Detector	Correction Factor (dB/m)	Reading (dB μ V)	Corrected Reading (dB μ V/m)	Limit @ 3 m (dB μ V/m)	Margin (dB)
Ground-parallel	0.07	AV	18.37	52.36	70.73	110.70	-39.97
Ground-parallel	0.13	AV	17.92	53.84	71.76	105.33	-33.57
Ground-parallel	0.19	AV	18.13	49.76	67.89	102.03	-34.14
Ground-parallel	0.31	AV	18.53	45.44	63.97	97.78	-33.81
Ground-parallel	0.43	AV	18.47	40.57	59.04	94.93	-35.89
Ground-parallel	0.79	QP	18.46	29.81	48.27	69.65	-21.38

Remark: Corr. Factor = Antenna Factor + Cable Loss

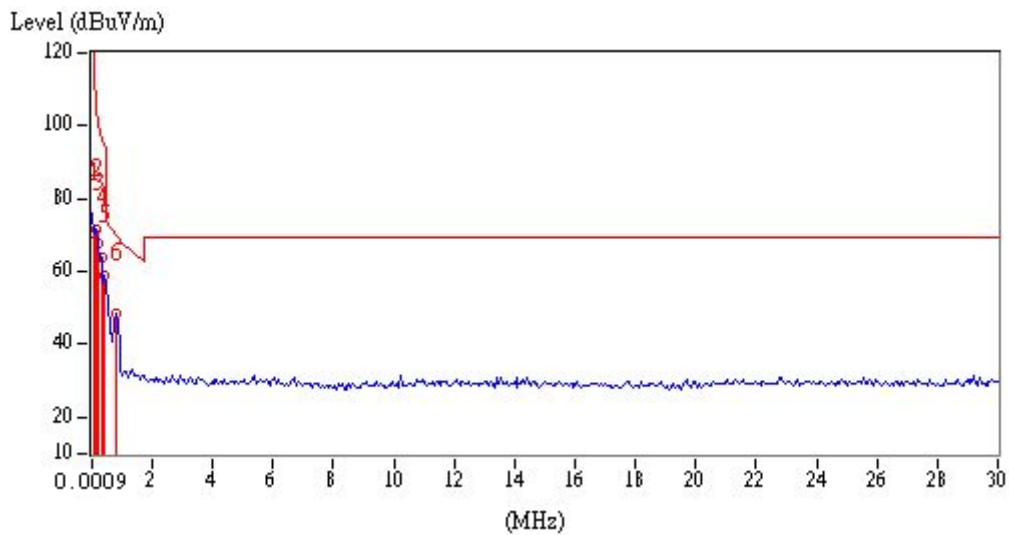

TEST REPORT

6.5.1 Measurement results: frequencies below 1 GHz

Temperature (°C) :	24
Relative Humidity (%) :	65
Test date :	2021/2/1

The test was performed on EUT under continuously transmitting mode. The worst case occurred at BLE 2M Channel 19.

Antenna Polarity	Frequency (MHz)	Detector	Factor (dB/m)	Reading (dB μ V)	Corrected Reading (dB μ V/m)	Limit @ 3m (dB μ V/m)	Margin (dB)
Vertical	37.76	QP	21.05	15.49	36.54	40.00	-3.46
Vertical	66.86	QP	20.03	9.19	29.23	40.00	-10.77
Vertical	97.90	QP	16.54	11.60	28.13	43.50	-15.37
Vertical	171.62	QP	21.33	7.40	28.73	43.50	-14.77
Vertical	185.20	QP	19.74	6.81	26.55	43.50	-16.95
Vertical	491.72	QP	27.34	14.80	42.14	46.00	-3.86

Remark: Corr. Factor = Antenna Factor + Cable Loss

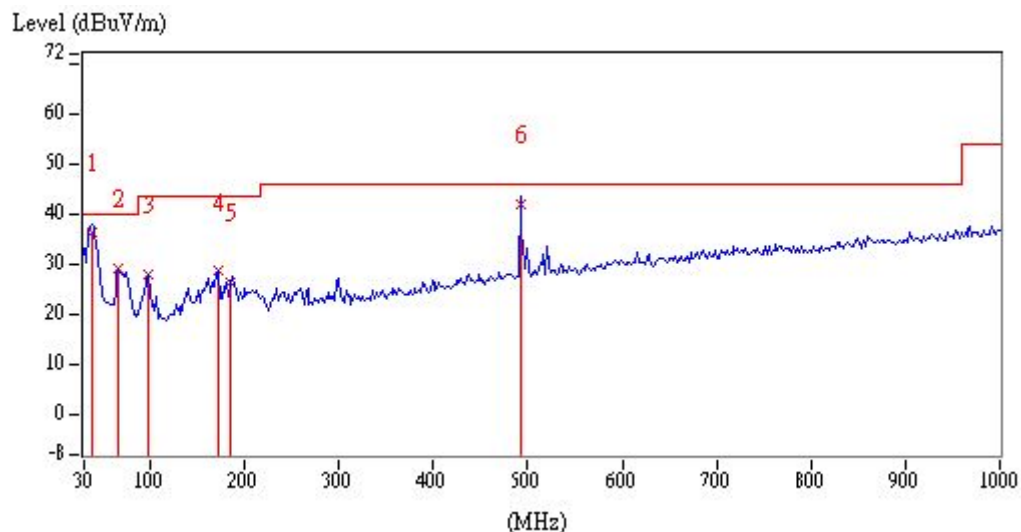

TEST REPORT

Antenna Polarity	Frequency (MHz)	Detector	Factor (dB/m)	Reading (dB μ V)	Corrected Reading (dB μ V/m)	Limit @ 3m (dB μ V/m)	Margin (dB)
Horizontal	35.82	QP	20.85	4.71	25.55	40.00	-14.45
Horizontal	95.96	QP	16.32	9.87	26.19	43.50	-17.31
Horizontal	284.14	QP	22.41	5.80	28.20	46.00	-17.80
Horizontal	295.78	QP	22.59	8.48	31.06	46.00	-14.94
Horizontal	491.72	QP	27.34	9.49	36.83	46.00	-9.17
Horizontal	522.76	QP	27.93	12.92	40.85	46.00	-5.15

Remark: Corr. Factor = Antenna Factor + Cable Loss

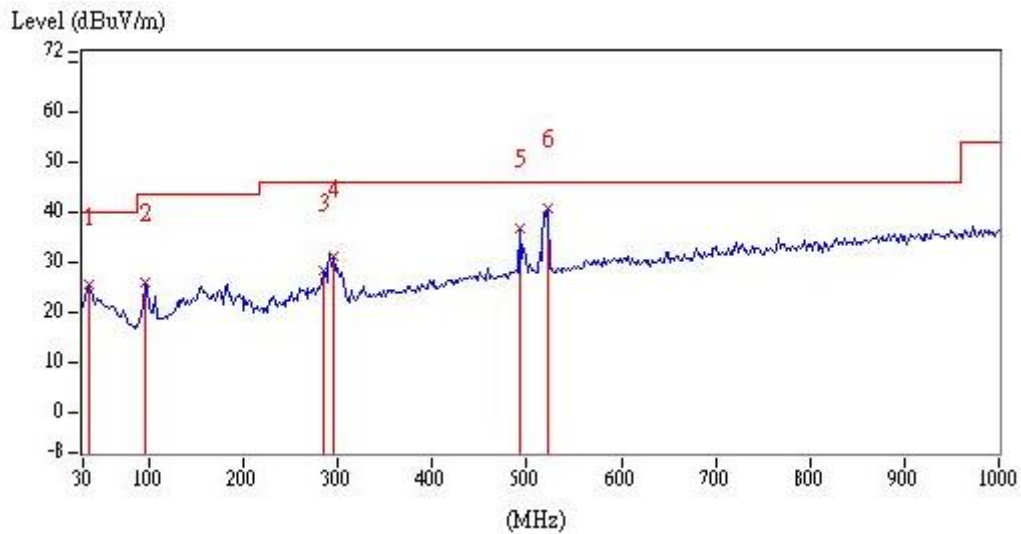

TEST REPORT

6.5.2 Measurement results: frequency above 1GHz to 25GHz

Temperature (°C) :	21
Relative Humidity (%) :	55
Test date :	2021/1/21

Mode	Frequency (MHz)	Spectrum Analyzer Detector	Ant. Pol. (H/V)	Correction Factor (dB/m)	Reading (dBμV)	Corrected Reading (dBμV/m)	Limit @ 3 m (dBμV/m)	Margin (dB)
BLE_1M_CHO	4804	PK	V	20.56	35.43	55.99	74	-18.01
	4804	AV	V	20.56	33.17	53.73	54	-0.27
	7206	PK	V	25.64	28.88	54.52	74	-19.48
	7206	AV	V	25.64	23.83	49.47	54	-4.53
	4804	PK	H	20.56	35.35	55.91	74	-18.09
	4804	AV	H	20.56	32.64	53.20	54	-0.80
BLE_1M_CH19	4880	PK	V	20.87	33.18	54.05	74	-19.95
	4880	AV	V	20.87	29.09	49.96	54	-4.04
	7320	PK	V	26.05	27.09	53.14	74	-20.86
	4880	PK	H	20.87	30.76	51.63	74	-22.37
	7320	PK	H	26.05	27.32	53.37	74	-20.63
BLE_1M_CH39	4960	PK	V	21.19	34.02	55.22	74	-18.78
	4960	AV	V	21.19	29.29	50.48	54	-3.52
	7440	PK	V	26.48	29.61	56.09	74	-17.91
	7440	AV	V	26.48	24.91	51.39	54	-2.61
	4960	PK	V	21.19	29.14	50.33	74	-23.67
	7440	PK	V	26.48	24.13	50.61	74	-23.39

TEST REPORT

Temperature (°C) :	24
Relative Humidity (%) :	56
Test date :	2021/2/8

Mode	Frequency (MHz)	Spectrum Analyzer Detector	Ant. Pol. (H/V)	Correction Factor (dB/m)	Reading (dBμV)	Corrected Reading (dBμV/m)	Limit @ 3 m (dBμV/m)	Margin (dB)
BLE_2M_CHO	4804	PK	V	20.56	38.15	58.71	74	-15.29
	4804	AV	V	20.56	30.19	50.75	54	-3.25
	4804	PK	H	20.56	39.04	59.60	74	-14.40
	4804	AV	H	20.56	32.83	53.39	54	-0.61
BLE_2M_CH19	4880	PK	V	20.87	35.53	56.40	74	-17.60
	4880	AV	V	20.87	30.49	51.36	54	-2.64
	7320	PK	V	26.05	32.64	58.69	74	-15.31
	7320	AV	V	26.05	20.43	46.48	54	-7.52
	4875	PK	H	20.85	36.86	57.71	74	-16.29
	4875	AV	H	20.85	29.53	50.37	54	-3.63
	7320	PK	H	26.05	28.90	54.95	74	-19.05
	7320	AV	H	26.05	18.97	45.02	54	-8.98
BLE_2M_CH39	4960	PK	V	21.19	30.89	52.09	74	-21.91
	4960	AV	V	21.19	25.32	46.52	54	-7.48
	7440	PK	V	26.48	33.60	60.08	74	-13.92
	7440	AV	V	26.48	20.87	47.35	54	-6.65
	4965	PK	H	21.21	31.40	52.61	74	-21.39
	4965	AV	H	21.21	24.88	46.09	54	-7.91
	7440	PK	H	26.48	31.77	58.25	74	-15.75
	7440	AV	H	26.48	20.98	47.46	54	-6.54

TEST REPORT

7. Emission on Band Edge

7.1 Instrument Setting

Spectrum Function	Setting
Detector	Peak and Average
RBW	1MHz
VBW	3MHz & 1/T Minimum VBW
Sweep	Auto couple
Restrict bands	2310 MHz ~ 2390 MHz 2483.5 MHz ~ 2500 MHz
Attenuation	Auto

7.2 Test Procedure

The test procedure is the same as Emissions in Restricted Frequency Bands (Radiated emission measurements).

7.3 Test Results

Temperature (°C) :	26
Relative Humidity (%) :	54
Test date :	2021/1/26

Mode	Frequency (MHz)	Spectrum Analyzer Detector	Ant. Pol. (H/V)	Correction Factor (dB/m)	Reading (dBμV)	Corrected Reading (dBμV/m)	Limit @ 3 m (dBμV/m)	Margin (dB)	Restricted band (MHz)
BLE 1M	2350.88	PK	H	35.46	21.13	56.59	74	-17.41	2310~2390
	2338.00	AV	H	35.40	10.57	45.96	54	-8.04	
	2488.24	PK	H	36.12	19.69	55.81	74	-18.19	2483.5~2500
	2488.72	AV	H	36.13	9.46	45.59	54	-8.41	

Remark: Correction Factor = Antenna Factor + Cable Loss

Restricted Band Bandedge @ BLE 1M Mode Ch0 PK

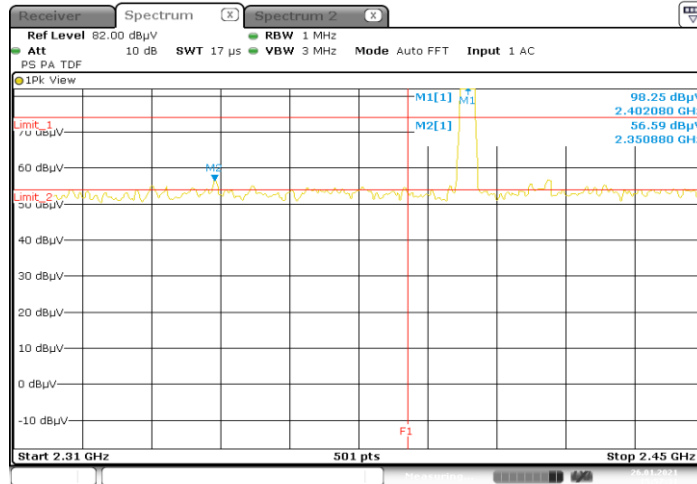

Date: 26 JAN 2021 15:57:31

Restricted Band Bandedge @ BLE 1M Mode Ch0 AV

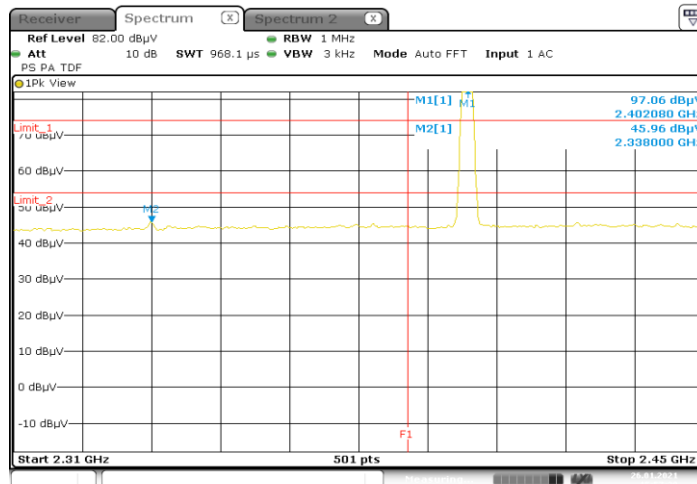

Date: 26 JAN 2021 15:57:20

Restricted Band Bandedge @ BLE 1M Mode Ch39 PK

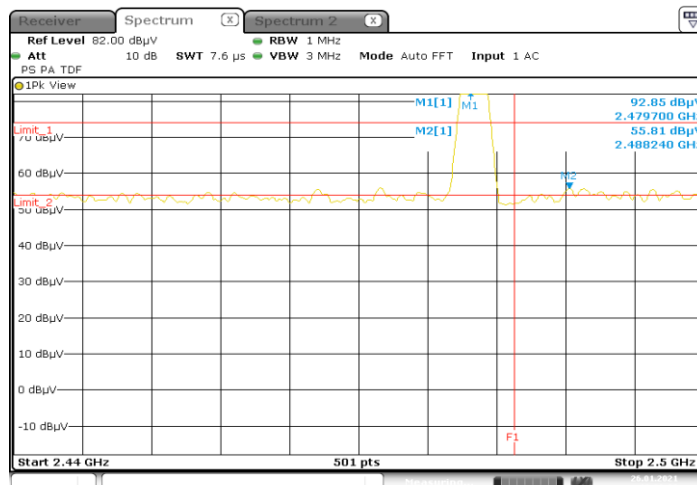

Date: 26 JAN 2021 16:06:09

Restricted Band Bandedge @ BLE 1M Mode Ch39 AV

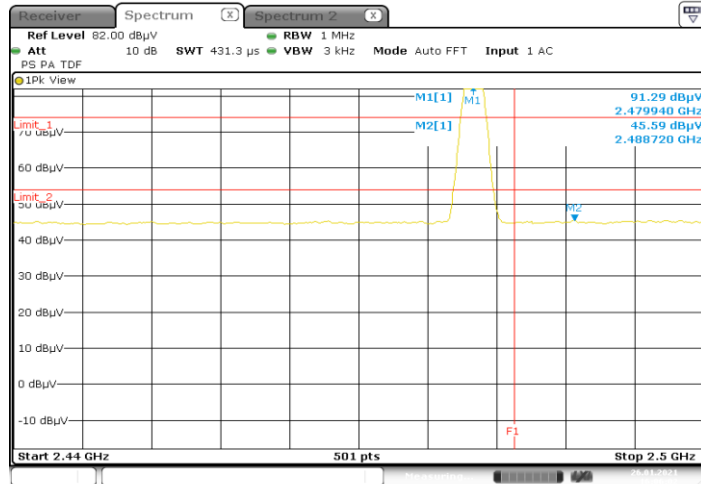

Date: 26 JAN 2021 16:06:03

TEST REPORT

Temperature (°C) :	24
Relative Humidity (%) :	56
Test date :	2021/2/8

Mode	Frequency (MHz)	Spectrum Analyzer Detector	Ant. Pol. (H/V)	Correction Factor (dB/m)	Reading (dBμV)	Corrected Reading (dBμV/m)	Limit @ 3 m (dBμV/m)	Margin (dB)	Restricted band (MHz)
BLE 2M	2382.52	PK	H	35.61	20.28	55.89	74	-18.11	2310~2390
	2337.72	AV	H	35.39	10.44	45.83	54	-8.17	
	2492.08	PK	H	36.14	19.09	55.23	74	-18.77	2483.5~2500
	2497.24	AV	H	36.17	9.16	45.33	54	-8.67	

Remark: Correction Factor = Antenna Factor + Cable Loss

Restricted Band Bandedge @ BLE 2M Mode Ch0 PK

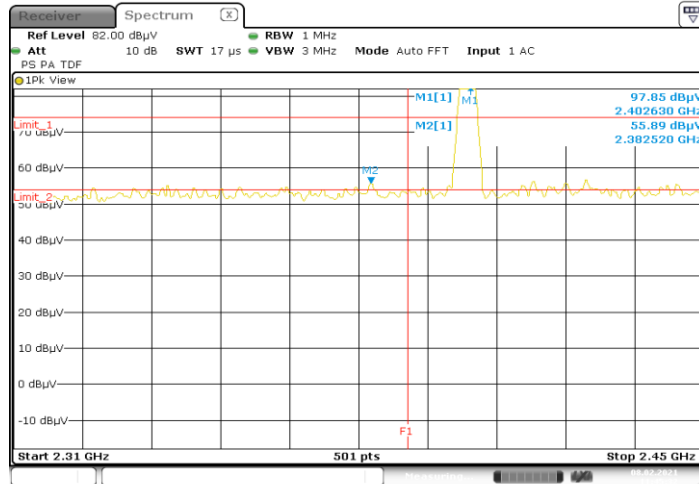

Date: 8.FEB.2021 11:45:33

Restricted Band Bandedge @ BLE 2M Mode Ch0 AV

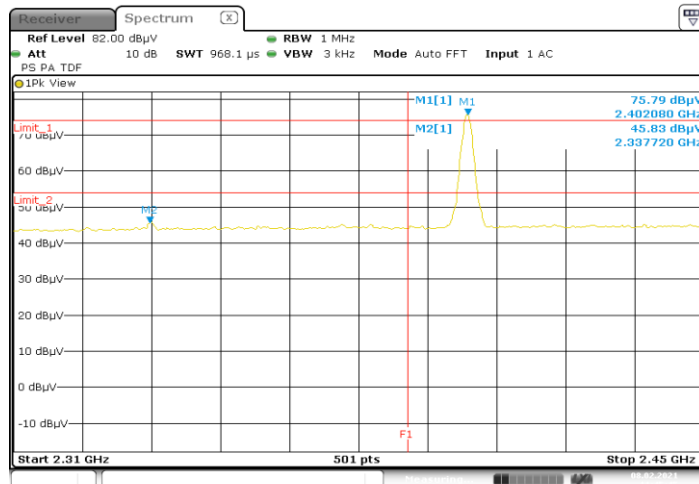

Date: 8.FEB.2021 11:45:45

Restricted Band Bandedge @ BLE 2M Mode Ch39 PK

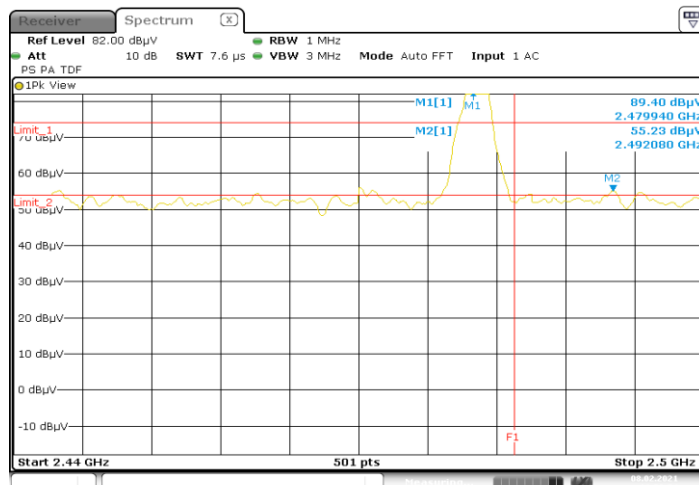

Date: 8.FEB.2021 11:52:54

Restricted Band Bandedge @ BLE 2M Mode Ch39 AV

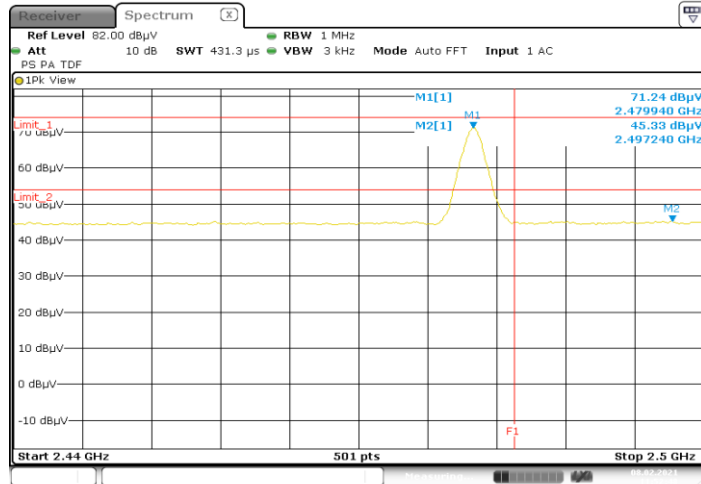

8. AC Power Line Conducted Emission

8.1 Measuring instrument setting

Receiver Function	Setting
Detector	QP
Start frequency	0.15MHz
Stop frequency	30MHz
IF bandwidth	9 kHz
Attenuation	10dB

8.2 Test Procedure

Step 1	Configure the EUT according to ANSI C63.10:2013. The EUT or host of EHT has to be placed 0.4 meter far from the conducting wall of the shielding room and at least 80 centimeters from any other grounded conducting surface.
Step 2	Connect EUT or host of EUT to the power mains through a line impedance stabilization network.
Step 3	All the companion devices are connected to the other LISN. The LISN should provide 50Uh/50ohms coupling impedance.
Step 4	The frequency range from 150 kHz to 30MHz was searched.
Step 5	Set the test-receiver system to peak detector and specified bandwidth with maximum hold mode.
Step 6	The measurement has to be done between each power line and ground at the power terminal.

8.3 Test Diagram

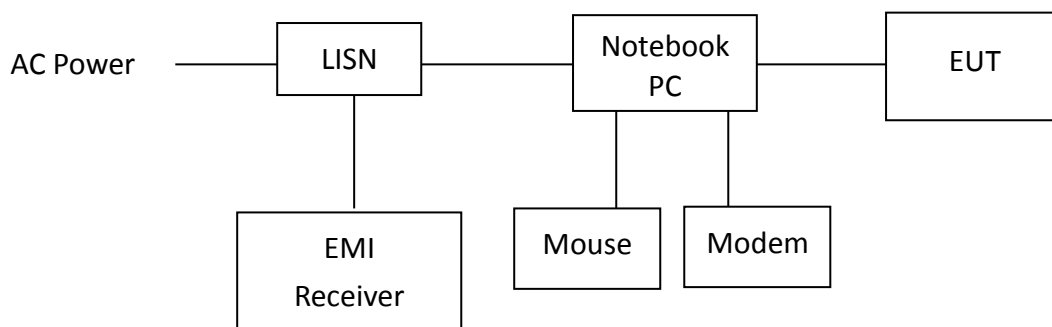

8.4 Limit

Frequency (MHz)	Conducted Limit (dBuV)	
	Q.P.	Ave.
0.15~0.50	66 – 56	56 – 46
0.50~5.00	56	46
5.00~30.0	60	50

TEST REPORT

8.5 Test Results

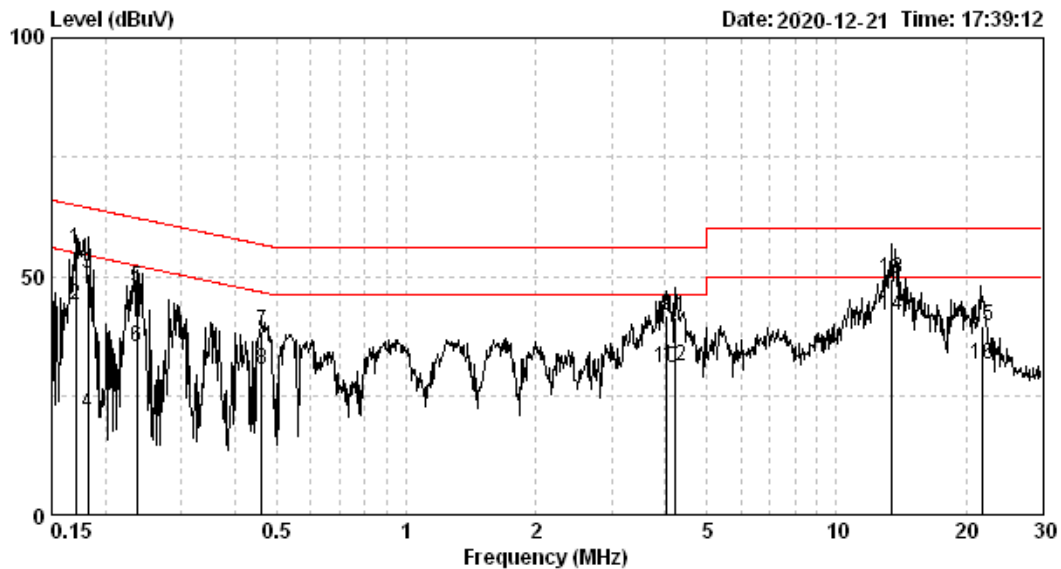

Test voltage : AC 120V 60Hz
 Temp. / R.H. : 23/51
 Atmospheric pressure : 1005

Phase	Frequency (MHz)	Corr. Factor (dB)	Reading QP (dBuV)	Level QP (dBuV)	Limit QP (dBuV)	Reading AV (dBuV)	Level AV (dBuV)	Limit AV (dBuV)	Margin (dB)	
									QP	AV
LINE	0.17	9.71	45.93	55.63	64.94	34.32	44.03	54.94	-9.31	-10.92
LINE	0.18	9.70	41.01	50.71	64.37	11.56	21.26	54.37	-13.66	-33.11
LINE	0.24	9.72	37.97	47.68	62.22	25.55	35.26	52.22	-14.53	-16.95
LINE	0.46	9.78	28.54	38.32	56.67	20.78	30.56	46.67	-18.35	-16.11
LINE	4.03	9.87	32.06	41.93	56.00	20.87	30.74	46.00	-14.07	-15.26
LINE	4.20	9.87	31.54	41.42	56.00	21.11	30.98	46.00	-14.58	-15.02
LINE	13.41	9.99	39.33	49.33	60.00	31.72	41.71	50.00	-10.67	-8.29
LINE	21.83	10.02	29.70	39.73	60.00	21.60	31.63	50.00	-20.27	-18.37

Remark:

1. Corr. Factor (dB) = LISN Factor (dB) + Cable Loss (dB)
2. Level (dBuV) = Corr. Factor (dB) + Reading (dBuV)
3. Margin (dB) = Level (dBuV) – Limit (dBuV)

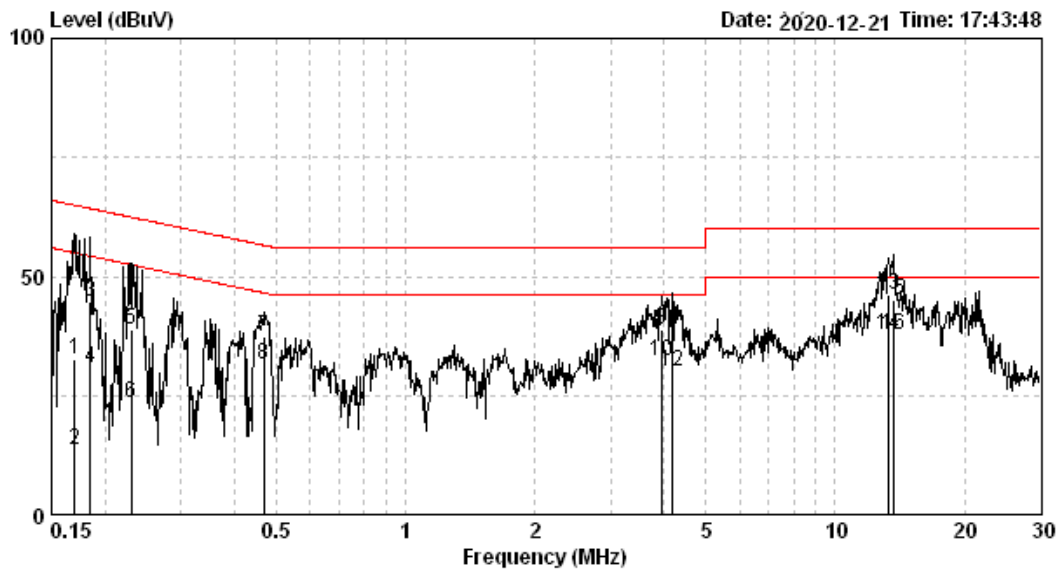

Test voltage :AC 120V 60Hz
 Temp. / R.H. :23/51
 Atmospheric pressure :1005

Phase	Frequency (MHz)	Corr. Factor (dB)	Reading QP (dBuV)	Level QP (dBuV)	Limit QP (dBuV)	Reading AV (dBuV)	Level AV (dBuV)	Limit AV (dBuV)	Margin (dB)	
									QP	AV
NEUTRAL	0.17	9.69	22.76	32.45	64.99	3.88	13.57	54.99	-32.54	-41.42
NEUTRAL	0.18	9.68	34.87	44.55	64.28	21.03	30.71	54.28	-19.73	-23.57
NEUTRAL	0.23	9.70	29.06	38.76	62.44	13.76	23.46	52.44	-23.68	-28.97
NEUTRAL	0.47	9.78	27.70	37.48	56.54	21.72	31.50	46.54	-19.06	-15.04
NEUTRAL	3.94	9.86	28.95	38.81	56.00	22.47	32.33	46.00	-17.19	-13.67
NEUTRAL	4.18	9.86	29.76	39.62	56.00	20.10	29.97	46.00	-16.38	-16.03
NEUTRAL	13.34	10.01	36.08	46.09	60.00	27.74	37.75	50.00	-13.91	-12.25
NEUTRAL	13.70	10.02	35.08	45.10	60.00	27.68	37.70	50.00	-14.90	-12.30

Remark:

1. Corr. Factor (dB) = LISN Factor (dB) + Cable Loss (dB)
2. Level (dBuV) = Corr. Factor (dB) + Reading (dBuV)
3. Margin (dB) = Level (dBuV) – Limit (dBuV)

Appendix A: Test equipment list

Test Equipment/ Test site	Brand	Model No.	Serial No.	Calibration Date	Next Calibration Date
EMI Test Receiver	Rohde & Schwarz	ESR7	101822	2020/08/18	2021/08/17
Spectrum Analyzer	Rohde & Schwarz	FSP30	100137	2020/08/25	2021/08/24
Signal Analyzer	Agilent	N9030A	MY51380492	2020/08/17	2021/08/16
Active Loop Antenna	SCHWARZBECK MESS-ELEKTRONIC	FMZB1519	1519-067	2020/04/13	2021/04/12
Broadband Antenna	SHWARZBECK	VULB 9168	9168-172	2020/06/02	2021/06/01
Horn Antenna	EMCO	3115	9906-5822	2020/05/07	2021/05/06
Horn Antenna	SCHWARZBECK	BBHA 9170	BBHA9170159	2020/08/20	2023/08/19
Pre-Amplifier	AML	AML0120L3401	0419-114	2020/12/16	2021/12/15
Pre-amplifier	SGH	SGH184	20201124-1	2020/12/16	2021/12/15
Power Meter	Anritsu	ML2495A	0844001	2020/10/28	2021/10/27
Power Sensor	Anritsu	MA2411B	0738452	2020/10/28	2021/10/27
966-2(A) Cable	SUHNER	SMA / EX 100	N/A	2020/08/17	2021/08/16
966-2(B) Cable	SUHNER	SUCOFLEX 104P	CB0005	2020/08/17	2021/08/16
RF Cable	SUHNER	SUCOFLEX 102	CB0006	2020/04/30	2021/04/29
Hight Pass Filter	Reactel	7HS-3G/18G-S11	N/A	2020/05/27	2021/05/26
20dB Attenuator	Mini-Circuits	BW-S20W5+	N/A	2020/05/27	2021/05/26
966-2_3m Semi-Anechoic Chamber	966_2	CEM-966_2	N/A	2020/02/23	2021/02/22
Test software	ADT	Radiated test system	V7.5.14	NCR	NCR

Note: No Calibration Required (NCR).

TEST REPORT

Test Equipment	Brand	Model No.	Serial No.	Calibration Date	Next Calibration Date
EMI Test Receiver	R&S	ESCI	100018	2020/11/20	2021/11/19
LISN	R&S	ENV216	101160	2020/07/17	2021/07/16
CON-2 Cable	SUHNER	EMCCFD300-B M-NM-6000	170502	2020/04/30	2021/04/29
Test software	Audix	e3	V4.20040112L	NCR	NCR

Note: No Calibration Required (NCR).

Appendix B: Measurement Uncertainty

This uncertainty represents an expanded uncertainty expressed at approximately the 95 % confidence level using a coverage factor of k=2.

Item	Uncertainty
Vertically polarized radiated disturbances from 30MHz~1GHz in a semi-anechoic chamber at a distance of 3m	5.13 dB
Horizontally polarized radiated disturbances from 30MHz~1GHz in a semi-anechoic chamber at a distance of 3m	5.22 dB
Vertically polarized Radiated disturbances from 1GHz~18GHz in a semi-anechoic chamber at a distance of 3m	4.29 dB
Horizontally polarized Radiated disturbances from 1GHz~18GHz in a semi-anechoic chamber at a distance of 3m	4.29 dB
Vertically polarized Radiated disturbances from 18GHz~26.5GHz in a semi-anechoic chamber at a distance of 1m	2.45 dB
Horizontally polarized Radiated disturbances from 18GHz~26.5GHz in a semi-anechoic chamber at a distance of 1m	2.45 dB
Radiated disturbances from 9kHz~30MHz in a semi-anechoic chamber at a distance of 3m	3.32 dB
Emission on the Band Edge Test	4.29 dB
Minimum 6 dB Bandwidth	7.69 %
Maximum Peak Conducted Output Power	0.37 dB
Power Spectral Density	1.15 dB
Emissions In Non-Restricted Frequency Bands	1.15 dB
AC Power Line Conducted Emission	2.58 dB