

样品承认规格书

PART SHEET FOR APPROVAL

制造商名称: Manufacturer:	深圳自由行通信技术有限公司
供应商名称 Supplier:	深圳自由行通信技术有限公司
产品名称: Part Description:	2.4G/5G 内置天线(L=110mm)
规格型号: Model No:	2.4G/5G 内置天线/黑色 FPC 1.13 黑色线 L=110mm 一代 IPEX <i>wifi-A</i>
物料编码: Cust P/N:	Z02-10062-R01 <i>360-100-191</i>
日期: Issued Date:	2020-09-23

供应商确认 Supplier confirmation

承办 Made By	审核 Engineer	批准 Approver
胡涛	古政华	邓凯

华曦达确认 SDMC confirmation

承认原因: Approval Reason:	<input type="checkbox"/> 新物料 New Part <input checked="" type="checkbox"/> 替代料 Substitute Part		
承办 Made By	审核 Engineer		批准 Approver
 2020.9.23	品质 Quality	研发 R&D	 2020.9.23
		 9.23	

备注: 签名表明提交样品获得承认, 图纸规格已经受控。Note: Signature indicates that the submitted sample is approved and the drawing/specification is now the controlling document.

地址: 深圳市南山区高新科技园科技南十二路 18 号长虹科技大厦 19 层
 Address: 19/F, Changhong Science & Technology Mansion, No.18, Keji South 12th Road, High-tech Industrial Park, Nanshan District, Shenzhen, China

样品承认规格书

PART SHEET FOR APPROVAL

制造商名称: Manufacturer:	深圳自由行通信技术有限公司
供应商名称 Supplier::	深圳自由行通信技术有限公司
产品名称: Part Description:	2.4G/5G 内置天线(L=110mm)
规格型号: Model No:	2.4G/5G 内置天线/黑色 FPC 1.13 黑色线 L=110mm 一代 IPEX
物料编码: Cust P/N:	Z02-10062-R01
日期: Issued Date:	2020-09-23

供应商确认 Supplier confirmation

承办 Made By	审核 Engineer	批准 Approver
胡涛	古政华	邓凯

华曦达确认 SDMC confirmation

承认原因: Approval Reason:	<input type="checkbox"/> 新物料 New Part <input type="checkbox"/> 替代料 Substitute Part		
承办 Made By	审核 Engineer		批准 Approver
	品质 Quality	研发 R&D	业务 Sales

备注: 签名表明提交样品获得承认, 图纸规格已经受控。Note: Signature indicates that the submitted sample is approved and the drawing/specification is now the controlling document.

地址: 深圳市南山区高新科技园科技南十二路 18 号长虹科技大厦 19 层
Address: 19/F, Changhong Science & Technology Mansion, No.18, Keji South 12th Road, High-tech Industrial Park, Nanshan District, Shenzhen, China

目 录

Index

一、 封面 (Cover)	1
二、 文件变更履历表 (Document Change Resume)	2
三、 目录 (Index)	3
四、 基本参数 (The basic parameters)	4
五、 工程图纸 (Product Drawing)	5
六、 测试设备 (Test Equipment & Conditions)	6
七、 性能测试报告 (Test Report)	7-11
八、 天线图片 (Antenna Picture)	12
九、 包装方式 (TEE PACKING WAY)	13

The basic parameters

A. Electrical Characteristics	
Frequency	2400 MHz ~2500MHz/ 5150 MHz~5850MHz
VSWR	<2
Efficiency	>40%
Impedance	50 Ohm
Polarization	Linear
Gain	2.4G/5G 3±1dBi
B. Material & Mechanical Characteristics	
Material of Radiator	
Cable Type	Φ1.13 Black
Connector Type	一代 IPEX
Dimension	
C. Environmental	
Operation Temperature	- 20 °C ~ + 60 °C
Storage Temperature	- 40 °C ~ + 80 °C

序号	品名	材料/规格	颜色	数量	备注
①	FPC	PI+电解铜	黑色	1	
②	∅1.13射频线	Cu+编织带	黑色	1	
③	背胶	3M 300LSE	黄色	1	
④	IPEX	第一代	金色	1	

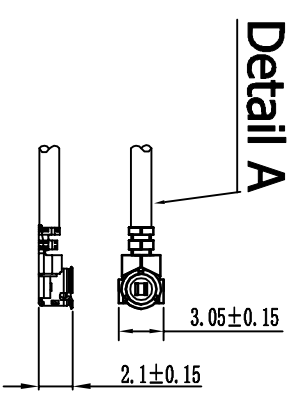
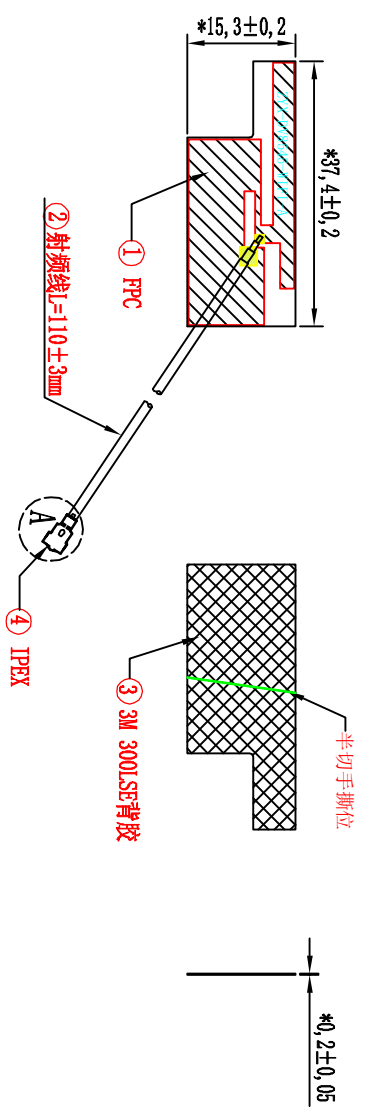

注:

- 1、标准*为重点尺寸,未标公差尺寸按±0.15检测
- 2、未标尺寸参考图纸;其它尺寸以实配为准;
- 3、▨为走线区域,▭为焊盘区域镀金,▩为附胶区域
- 4、产品不能有油污、灰尘、毛刺等;
- 5、符合ROHS

深圳自由行通信技术有限公司

第三角法	机种	DWG545	日期	2020/09/22	页码	
0~10	±0.10	○	0.02	品名	内置天线/A	绘图
10~20	±0.15	○	∅0.03	料号	Z02-10062-R01	设计审核
20~40	±0.20	∟	0.02	基材	一对半	审核
40~	±0.25	∟	0.04	外观处理		射频
		∟	0.02			李文科
				单位		
				mm		
				比例		
				版本	R:A	

Test Equipment & Conditions

1. Network Analyzers :

Agilent 8753D 5071B

2. Communications Test Set:

Agilent 8960

3. 3D Chamber Test System

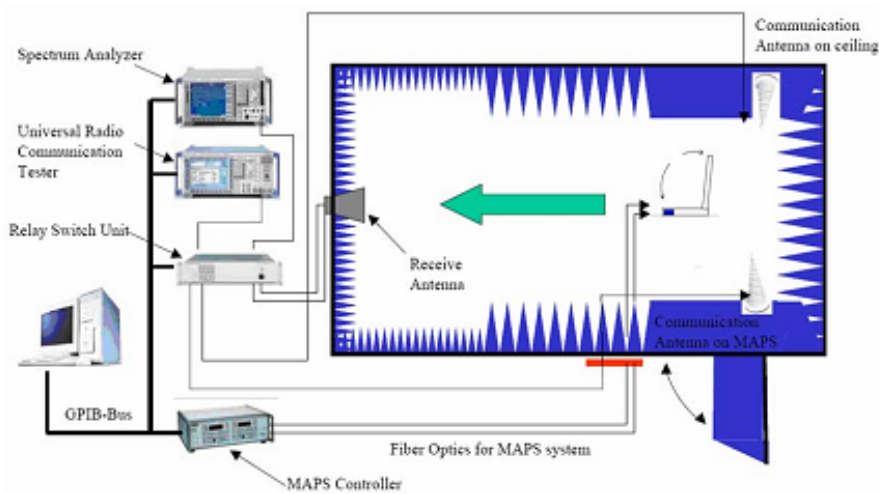

(Testing by 3D anechoic chamber)

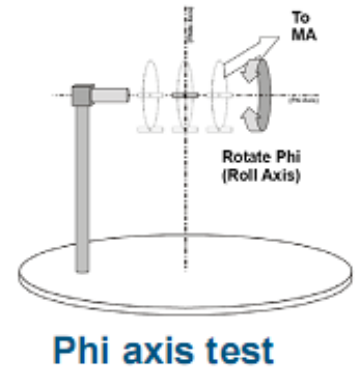

Phi axis test

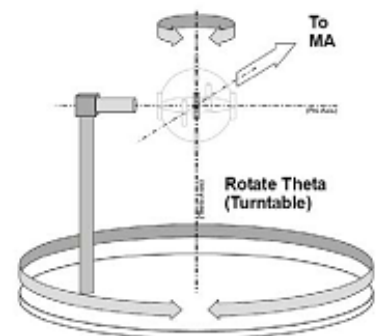

Theta axis test

测试数据



效率&增益:
Efficency&Gain

2.4G 测试数据

Freq(MHz)	Effi (%)	Gain(dBi)
2400	57.94	3.01
2410	54.7	2.54
2420	61.66	3.01
2430	56.62	2.39
2440	60.12	2.7
2450	57.41	2.46
2460	63.97	3.41
2470	54.95	2.83
2480	53.58	3.21
2490	55.46	3.34
2500	56.49	3.96

5.8G 测试数据

Freq(MHz)	Effi (%)	Gain(dBi)
5150	65.31	3.89
5200	64.27	4.15
5250	64.42	3.44
5300	66.83	3.52
5350	59.16	3.75
5400	57.68	3.35
5450	67.45	3.89
5500	48.98	2.33
5550	47.21	2.1
5600	56.89	2.97
5650	51.29	2.38
5700	45.5	2.57
5750	49.32	2.03
5800	47.75	2.85
5850	51.88	2.17

方向图 (3D)

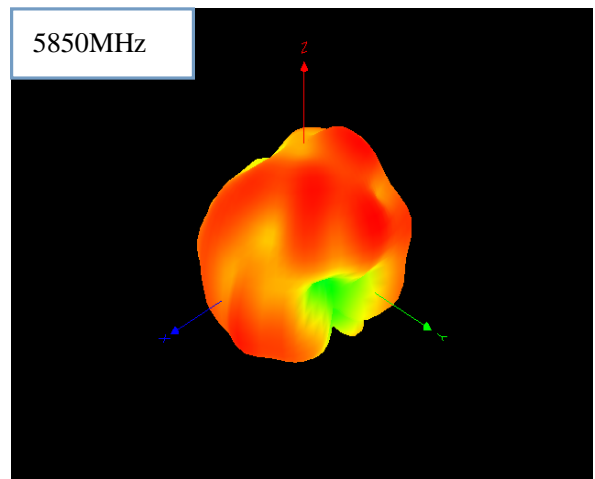
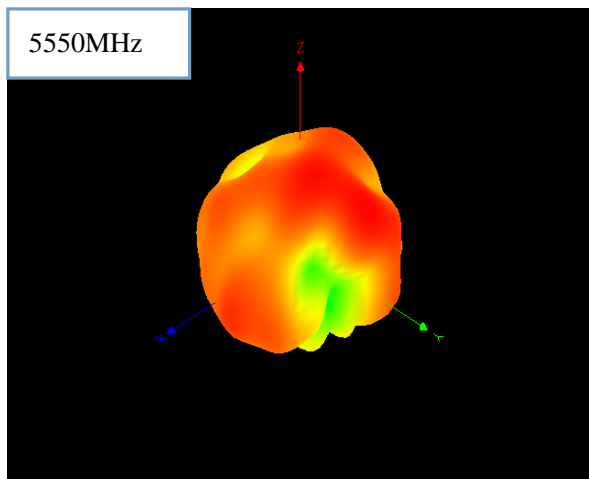
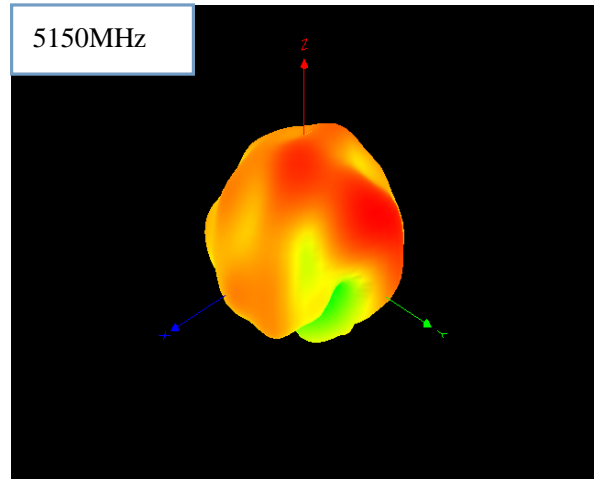
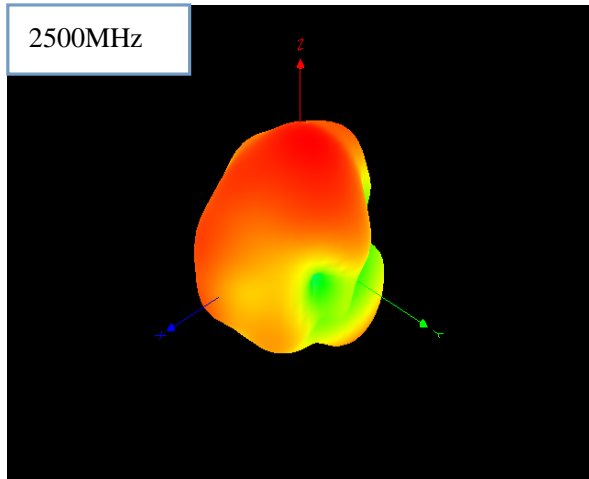
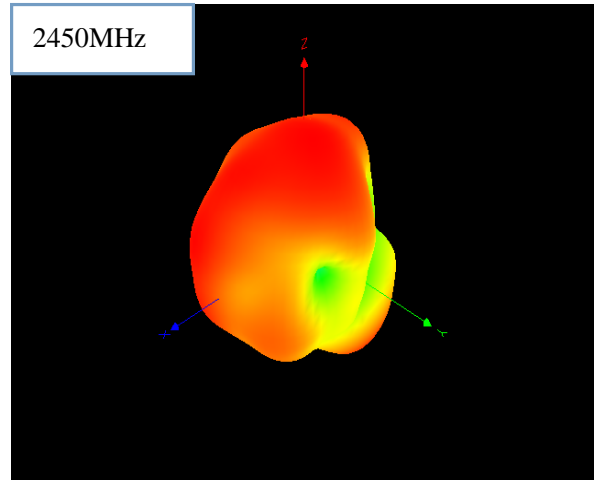
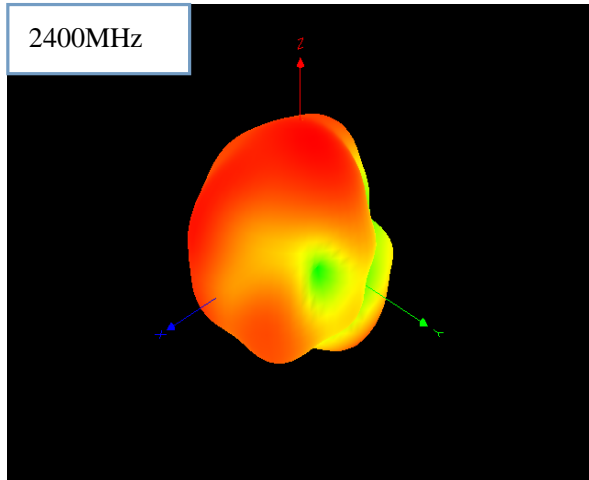

方向图 (3D)

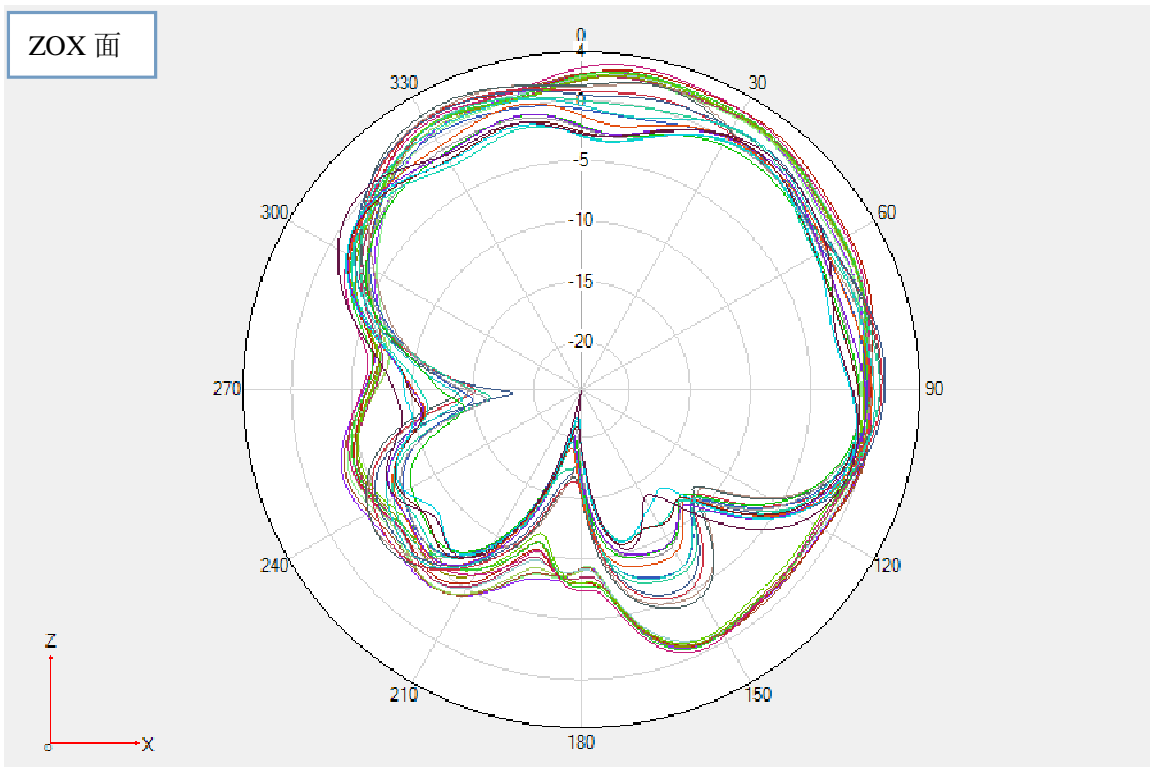
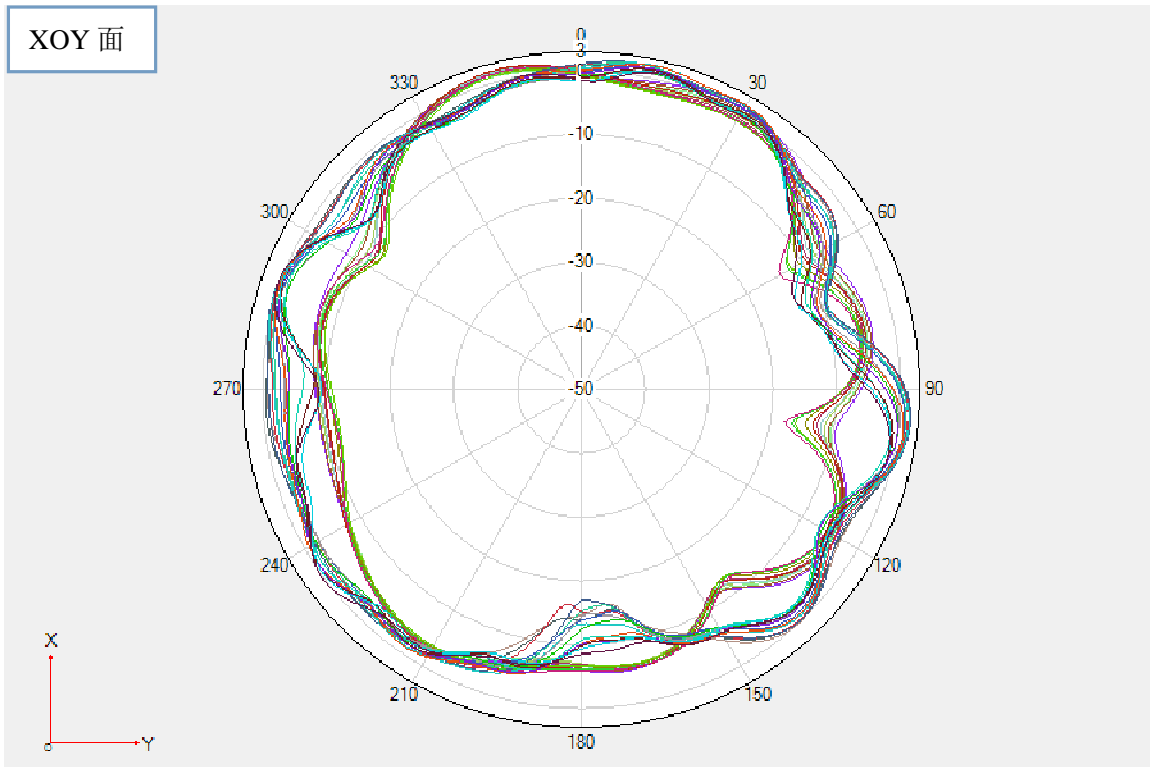

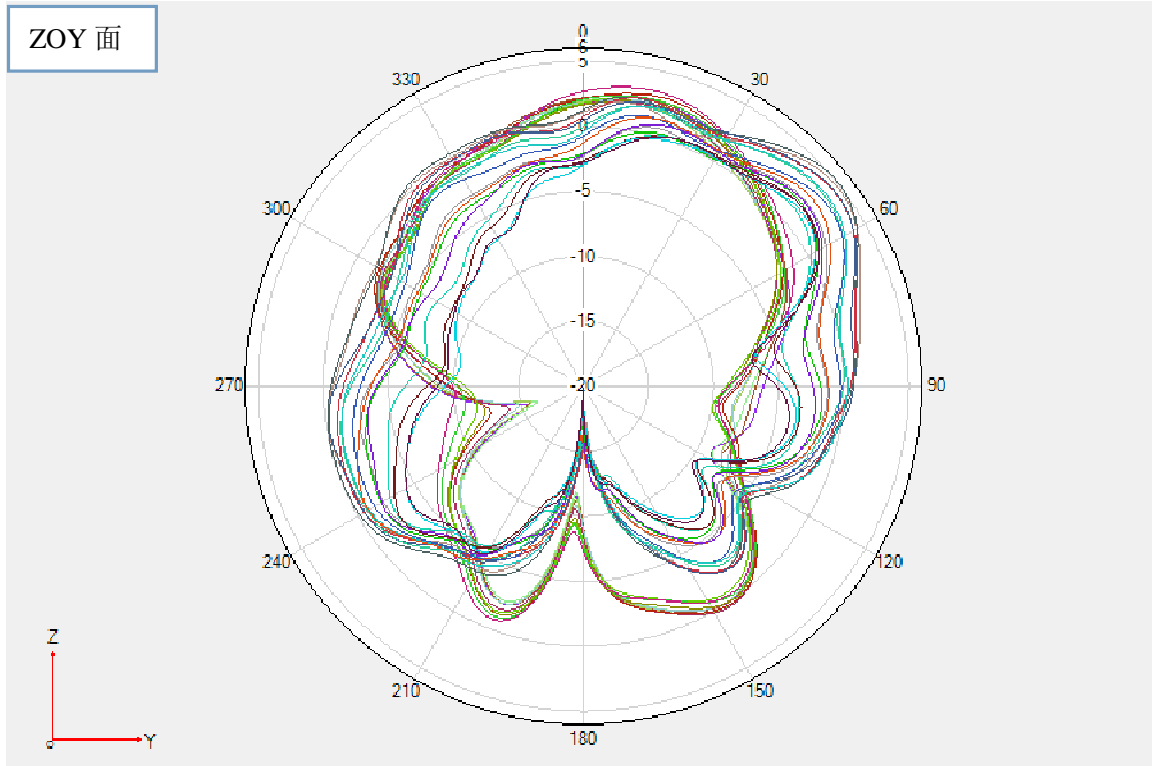

天线图片

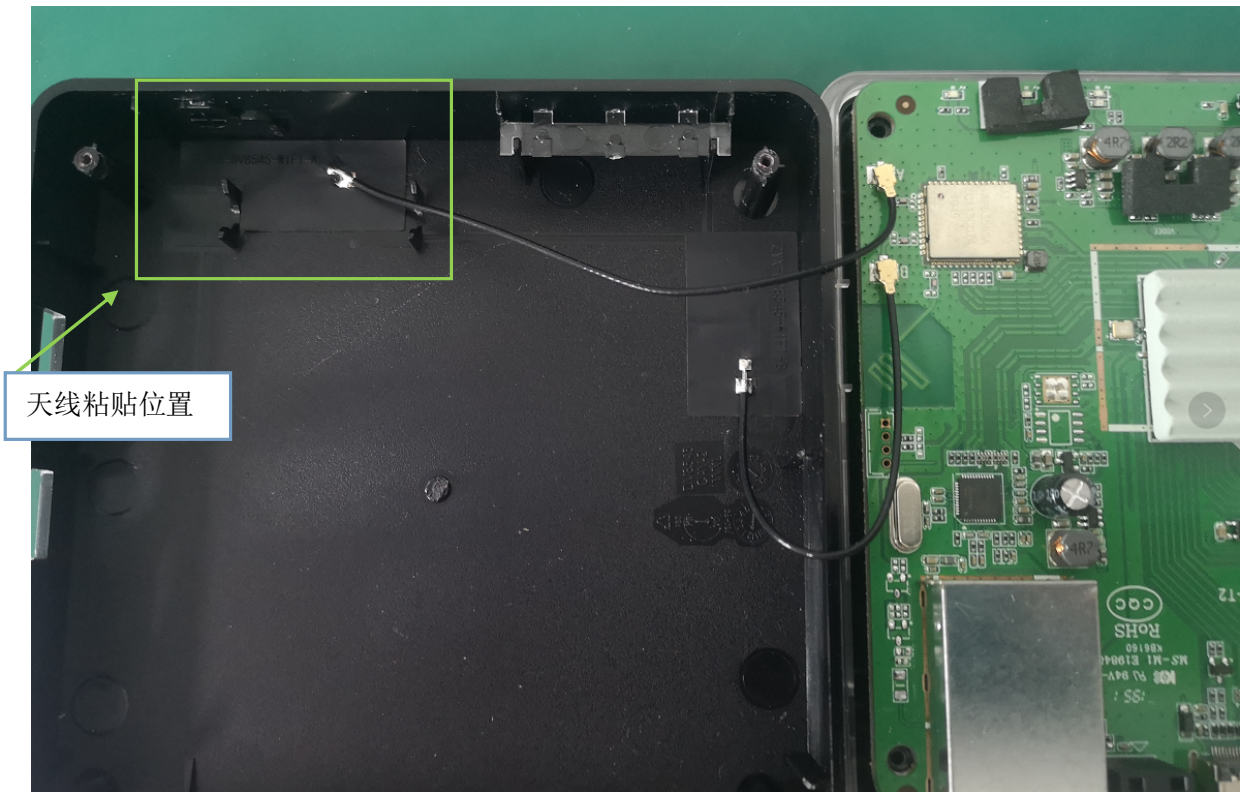

产品包装规范

page: 1 of 1

产品名称 :内置天线

版本: A00

客户特殊要求除外

一: 成品天线

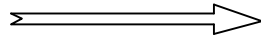
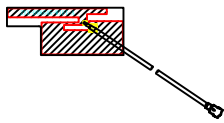

二: 用PE袋装起来, 数量以 (50 100PCS) 整数装
以实际为准

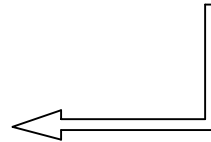
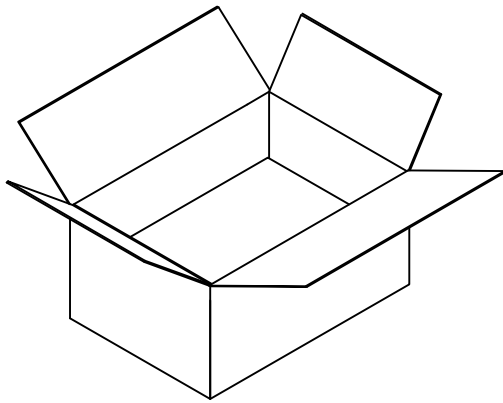
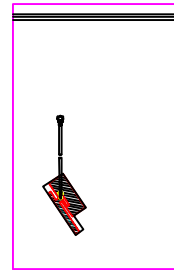

三: 将装好的天线放入纸箱中(以实际数量为准)

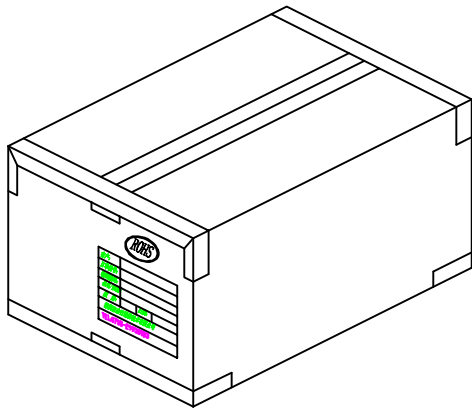
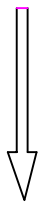

四: 封箱, 外箱贴我司生产标签和
ROHS标签(最终以实际情况为
准!)