

样品承认规格书

PART SHEET FOR APPROVAL

制造商名称: Manufacturer:	万物相连通讯襄阳有限公司 All things connected Communications Xiangyang Limited
供应商名称 Supplier:	万物相连通讯襄阳有限公司 All things connected Communications Xiangyang Limited
产品名称: Part Description:	Built-in antenna 内置天线
规格型号: Model No:	WWXL6010193
制造商P/N: Manufacturer P/N:	ANT00210-1A
编码:P/N: 日期:	360100425
Issued Date:	2023. 09. 13

供应商确认 Supplier confirmation

承办 Made By	审核 Engineer	批准 Approver
DAIHONGBO		TONGXIAOYAN

confirmation

承认原因: Approval Reason:	<input type="checkbox"/> 新物料 New Part <input type="checkbox"/> 替代料 Substitute Part		
承办 Made By	审核 Engineer		批准 Approver
	品质 Quality	研发 R&D	业务 Sales

备注: 签名表明提交样品获得承认, 图纸规格已经受控。 Note: Signature indicates that the submitted sample is approved and the drawing/specification is now the controlling document.

INDEX 目录

cover 封面.....	1
Index 目录.....	2
一、Product pictures 产品成品图.....	3
二、Test parameters 产品测试参数.....	3
三、Antenna test environment 天线测试环境.....	4
四、Antenna Passive Parameters 天线无源参数:	5
1、VSWR 驻波比图.....	5
2、Directional、Gain and Efficiency 增益和效率.....	5
3、2D/3D directional diagram 2D/3D 方向图.....	6
五、Product features 产品特点.....	6
六、Drawing 产品结构图.....	7
七、Specification for wire rod 线材规格书.....	8
八、Terminal material report 端子材质报告.....	9
九、Reliability testing 环境可靠性试验报告.....	10
1.Environmental experiment 环境试验.....	10
2. Salt spray test 盐雾试验.....	11
3. Tensile test 拉力试验.....	12
十、Packing instructions 包装说明.....	13
十一、Material Composition Declaration 材料成分申明.....	14
十二、SVHC substances questionnaire for REACH regulations REACH 法规 SVHC 物质调查表.....	15

Shenzhen all things connected Communication Co.,Ltd.
All things connected Communications Xiangyang Limited
Add: Room 1101,Building 4,Fangdacheng,No2,longxhu 4th Road, Nanshan District, Shenzhen City
Add: Hubei Xiangyang Gucheng County 1-3 Shuang Yang Road Taoyuan Street,All things connected industrial park,

Specification for Antenna 天线规格书

一、Product pictures 产品图片

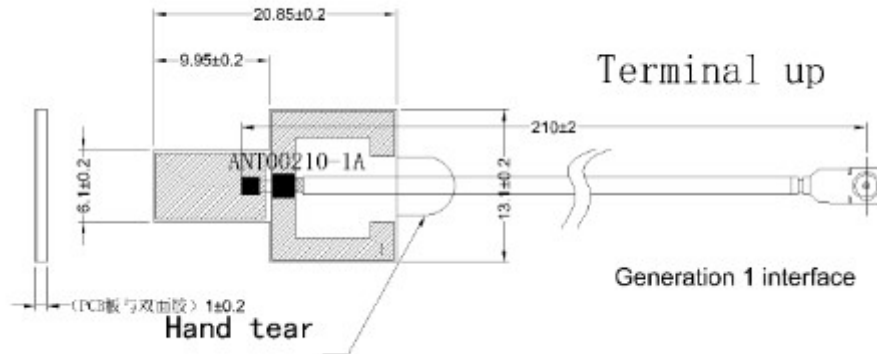

二、Test parameters 产品测试参数

产品名称 Name 内置天线 (WWXL6010193)		型号 Model Type	
电气参数 ELECTRICAL SPECTFICATIONS		机械参数 MECHANICAL SPECTFICATIONS	
频率范围 Frequency Range 5150-5850MHz		尺寸 Dimensions	20.85*13.1*1.0mm
输入阻抗 Impedance	50 Ω	连接器型号 Connector	IPEX
驻波比 VSWR	≤2.0	线长 line length	210±2mm 1.13 Low loss line black 低损耗线黑色
增益 Gain	≥2.63dBi	效率 Efficiency	≥24.4%
极化方式 Polarization	linear Vertical 线极化	工作温度 Working Temperature	-45°C - +85°C
辐射方向 Radiation	Omnidirectional 全向	存放温度 Limit Temperature	-45°C - +85°C

Shenzhen all things connected Communication Co.,Ltd.
All things connected Communications Xiangyang Limited
Add: Room 1101, Building 4, Fangdacheng, No2, longxhu 4th Road, Nanshan District, Shenzhen City
Add: Hubei Xiangyang Gucheng County 1-3 Shuang Yang Road Taoyuan Street, All things connected industrial park,

三、Antenna test environment 天线测试环境

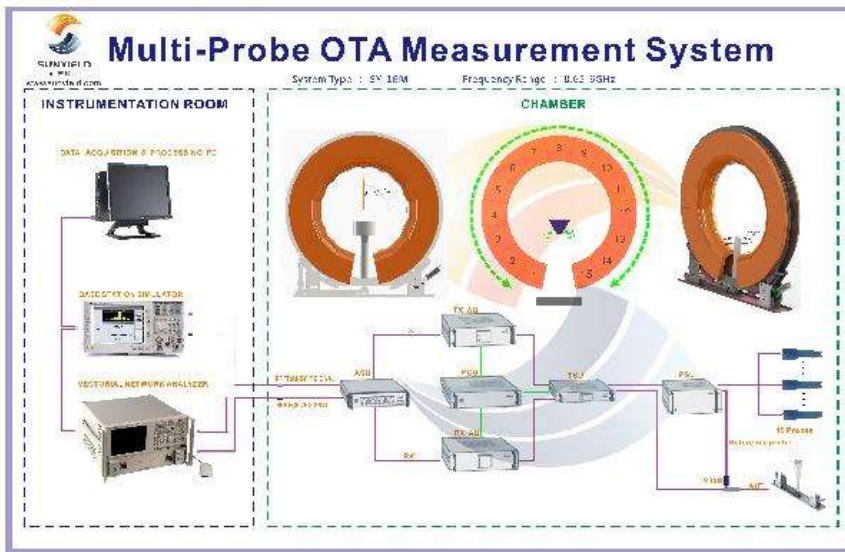
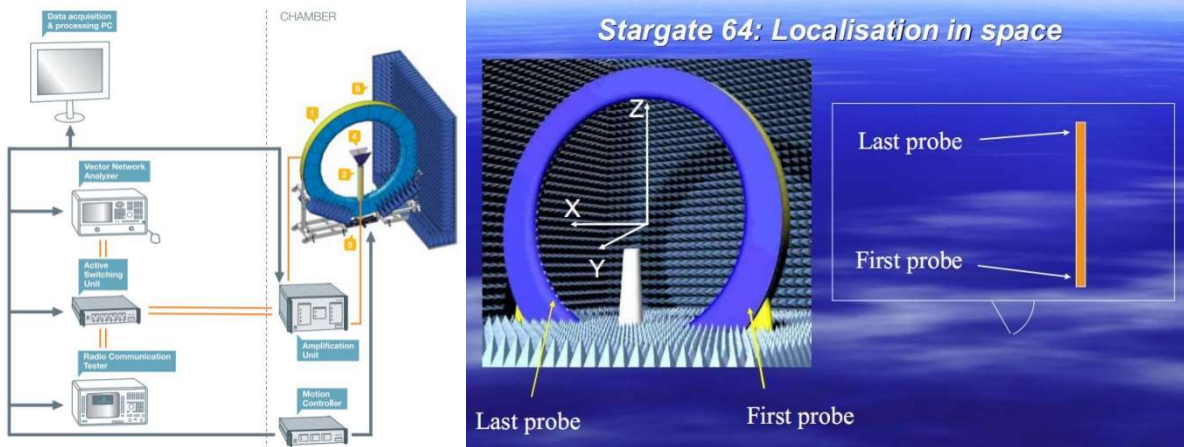

test macro 测试系统:	SY-16M Antenna measurement system 天线测量系统
testing environment 测试环境:	temperature 温度 22°C ± 3°C, humidity 湿度 50% ± 15%
testing equipment 测试设备:	Agilent 5071C Agilent 8960 Comprehensive measuring instrument 综测仪 Agilent CMW500 4G Comprehensive measuring instrument 综测仪

Shenzhen all things connected Communication Co.,Ltd.
 All things connected Communications Xiangyang Limited
 Add: Room 1101,Building 4,Fangdacheng,No2,longxhu 4th Road, Nanshan District, Shenzhen City
 Add: Hubei Xiangyang Gucheng County 1-3 Shuang Yang Road Taoyuan Street,All things connected industrial park,

四、Antenna Passive Parameters 天线无源参数:

1、VSWR驻波比图:

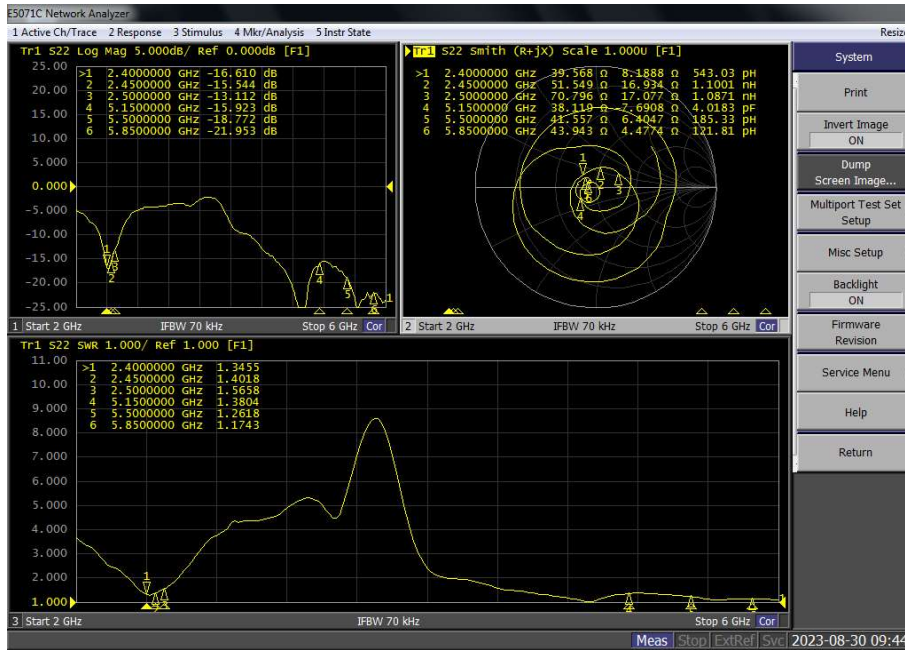

V.S.W.R

Freq/GHz	5.15	5.5	5.85
VSWR	1.3	1.2	1.1

3、Gain and Efficiency 增益和效率:

Gain&Efficiency&PhaseCenter 增益、效率和相位中心								
frequency 频率 (MHz)	gain 增 益(dBi)	efficiency 效率(%)	frequency 频率 (MHz)	gain 增益 (dBi)	efficiency 效率(%)	frequency 频率 (MHz)	gain 增益 (dBi)	efficiency 效率(%)
5150	3.33	58.78	5700	2.84	54.71			
5200	3.5	58.42	5750	2.79	53.91			
5250	3.64	58.82	5800	2.99	54.58			
5300	3.75	58.73	5850	2.63	53.85			
5350	3.67	57.72						
5400	3.65	57.49						
5450	3.5	56.74						
5500	3.28	55.64						
5550	2.98	54.44						
5600	2.86	54.21						
5650	2.84	54.56						

Shenzhen all things connected Communication Co.,Ltd.

All things connected Communications Xiangyang Limited

Add: Room 1101,Building 4,Fangdacheng,No2,longxhu 4th Road, Nanshan District, Shenzhen City

Add: Hubei Xiangyang Gucheng County 1-3 Shuang Yang Road Taoyuan Street,All things connected industrial park,

4、2D/3D directional diagram 2D/3D方向图：

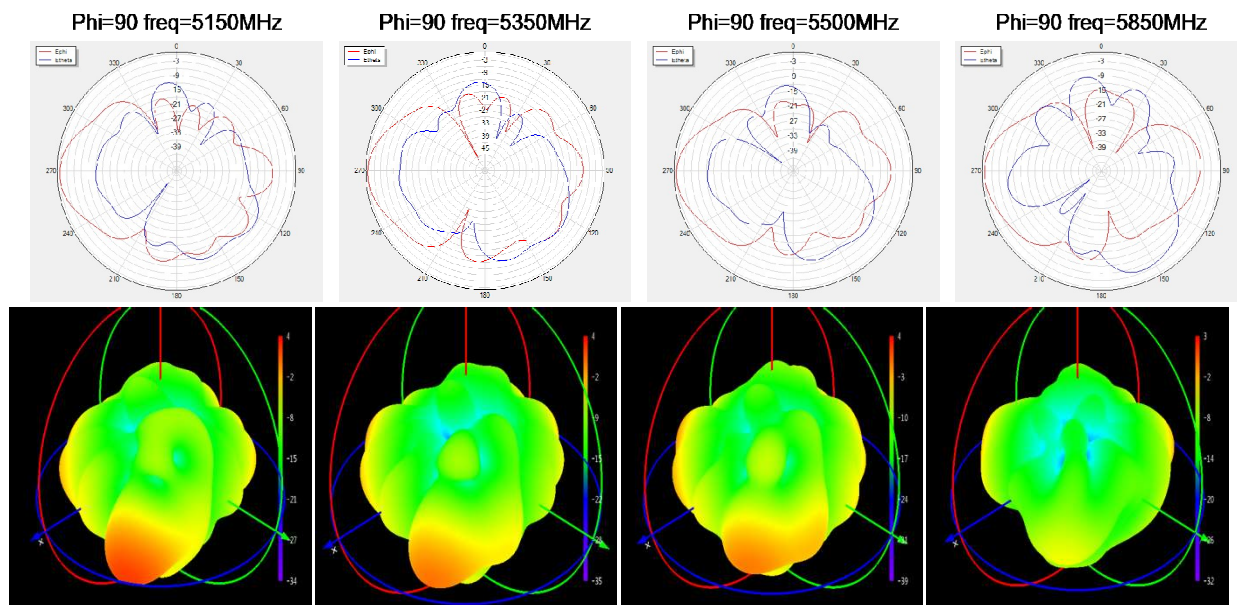

五、Product characteristics产品特点

1. Choose high-quality RF cable with small attenuation 选用优质射频电缆，自身衰减小；
2. Stable performance 性能稳定；
3. Stable performance 频带内驻波良好。

Shenzhen all things connected Communication Co.,Ltd.
All things connected Communications Xiangyang Limited
Add: Room 1101,Building 4,Fangdacheng,No2,longxhu 4th Road, Nanshan District, Shenzhen City
Add: Hubei Xiangyang Gucheng County 1-3 Shuang Yang Road Taoyuan Street,All things connected industrial park,

六、Drawing产品结构图

由 Autodesk 教育版产品制作

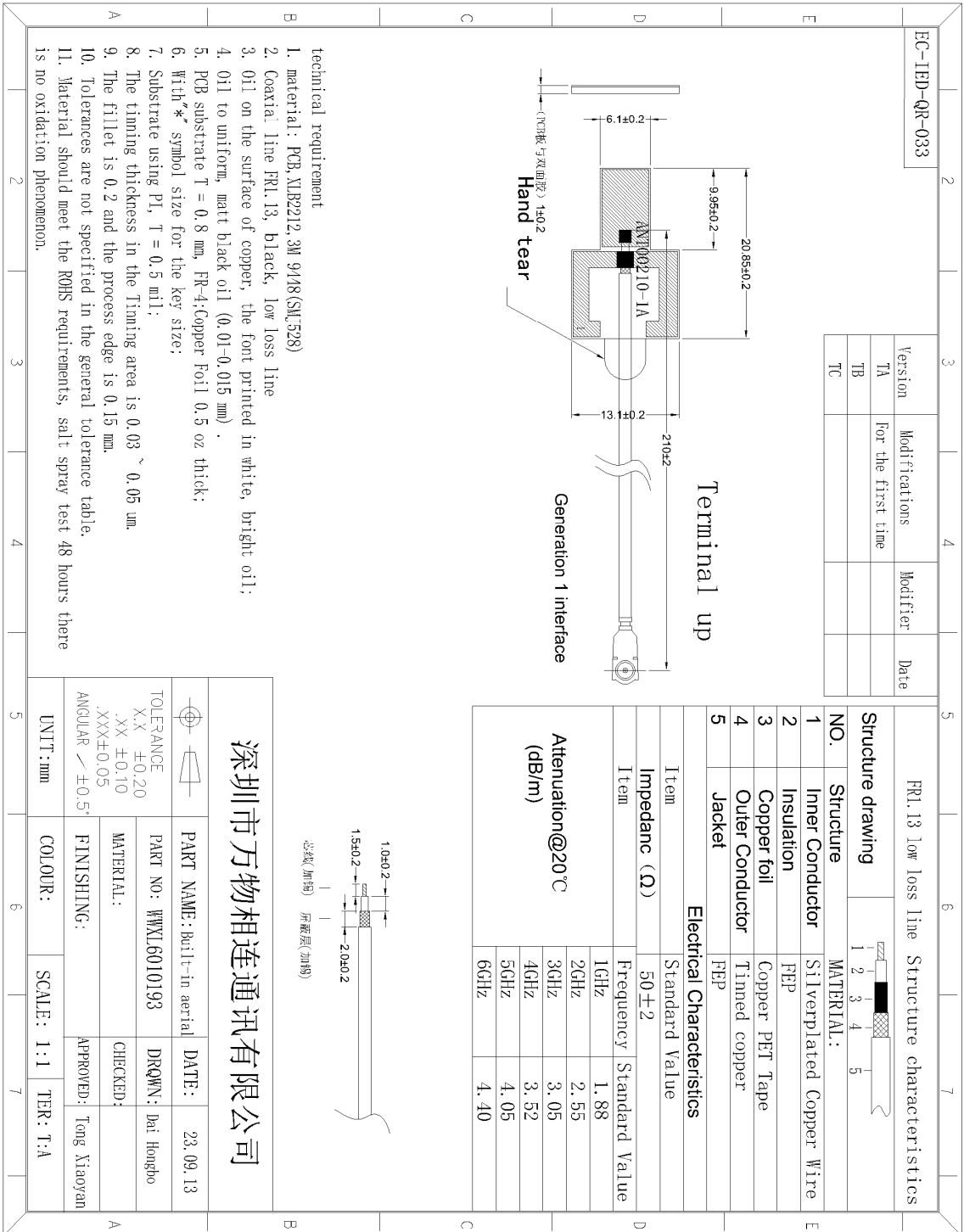

由 Autodesk 教育版产品制作

由 Autodesk 教育版产品制作

Shenzhen all things connected Communication Co.,Ltd.
 All things connected Communications Xiangyang Limited
 Add: Room 1101,Building 4,Fangdacheng,No2,longxhu 4th Road, Nanshan District, Shenzhen City
 Add: Hubei Xiangyang Gucheng County 1-3 Shuang Yang Road Taoyuan Street,All things connected industrial park,

七、Specification for wire rod线材规格书

产品规格 Product Type		RF113L-F 单银		
结构图 Structure Drawing				
结构特性 Structure Characteristics				
结构 Structure	项目 Item	标准值 Standard Value		
内导体 Inner Conductor	材质 Material	镀银铜线 Silverplated Copper Wire		
	结构 Construction(mm)	7/0.085		
	标称外径 Nom. Dia (mm)	0.25±0.02		
绝缘层 Insulation	材质 Material	聚全氟乙烯 FEP		
	标称外径 Nom. Dia (mm)	0.715±0.03		
外导体 Outer Conductor	材质 Material	铜箔箔 Copper plastic foil		
	标称外径 Nom. Dia (mm)	0.72±0.05		
外导体 Outer Conductor	材质 Material	铜箔箔+镀银铜线 TC Wire		
	标称外径 Nom. Dia (mm)	0.93±0.05		
	编织覆盖率 Coverage Ratio(%)	90±5		
护套 Jacket	材质 Material	聚全氟乙烯 FEP		
	标称外径 Nom. Dia (mm)	1.15±0.05		
电气性能 Electrical Characteristics				
项目 Item	标准值 Standard Value	项目 Item	频率 Frequency	标准值 Standard Value
阻抗 Impedance (Ω)	50±2	衰减 Attenuation @ 20 °C (dB/m)	1 GHz	1.88
电容 Capacitance (pF/m)	98		2 GHz	2.55
速率 Velocity (%)	70		3 GHz	3.05
驻波比 VSWR	≤ 1.30@ DC-6GHz		4 GHz	3.52
最大工作电压 Max. Operating Voltage(V)	1000		5 GHz	4.05
最大工作频率 Max. Operating Frequency(GHz)	6		6 GHz	4.40
可靠性 Dependability				
最小弯曲半径(单次) Min. Bending Radius/Single		mm	5	
最小弯曲半径(重复) Min. Bending Radius/Repeated		mm	10	
工作温度范围 Operating Temperature		°C	-55- +200	
包装 Packing				
包装方式 Packing Mode	纸盘 Papery Reel			
包装长度 The Length of Each Reel(m)	1000			
每盘段数 The Joints of Each Reel	≤5			
最小段长 Min. Segment Length(m)	≥20			
使用提示 Trips for Use				
存储环境 Storage Environment	温度: 30°C以下, 湿度: 20-65%			
最佳保存周期 The Best Save Cycle	2 个月, 2 个月以上上锡效果变差, 但电性能不受影响, 夏季高温高湿环境开封后需尽快流转			
加工温度 Processing Temperature	可短时承受 260°C 的高温, 300°C 以上易发生分解, 400°C 以上发生显著的热分解			
铁氟龙收缩 Teflon Shrink	材料的固有属性, 绝缘 0.2mm 以下, 护套 0.3mm 以下			
护套窜动 Jacket Taaverse	加工长度(护套预留长度) 低于 5CM 时易发生			

Shenzhen all things connected Communication Co.,Ltd.
 All things connected Communications Xiangyang Limited
 Add: Room 1101,Building 4,Fangdacheng,No2,longxhu 4th Road, Nanshan District, Shenzhen City
 Add: Hubei Xiangyang Gucheng County 1-3 Shuang Yang Road Taoyuan Street,All things connected industrial park,

八、Terminal material report 端子材质报告

化学成分 CHEMICAL COMPOSITION %					化学标准 JIS H 3100:2012			
Cu	Sn	P	Zn	Ni	Pb	Fe	Al	Cu+Sn+P≥
64.06	0.002	0.0003	35.91	/	0.0055	0.002	0.0001	/

物理性能 PHYSICAL PROPERTY			性能标准 JIS H 3100:2012		件数	重量/kg
抗拉 (Mpa)	延伸率 (%)	维氏硬度 (HV)	公差 (mm)	弯曲试验		
524	8	175	-0.01	无裂纹		
降伏 (Mpa)	粗糙度 正 (um)	粗糙度 反 (um)				
/	/	/				

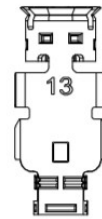
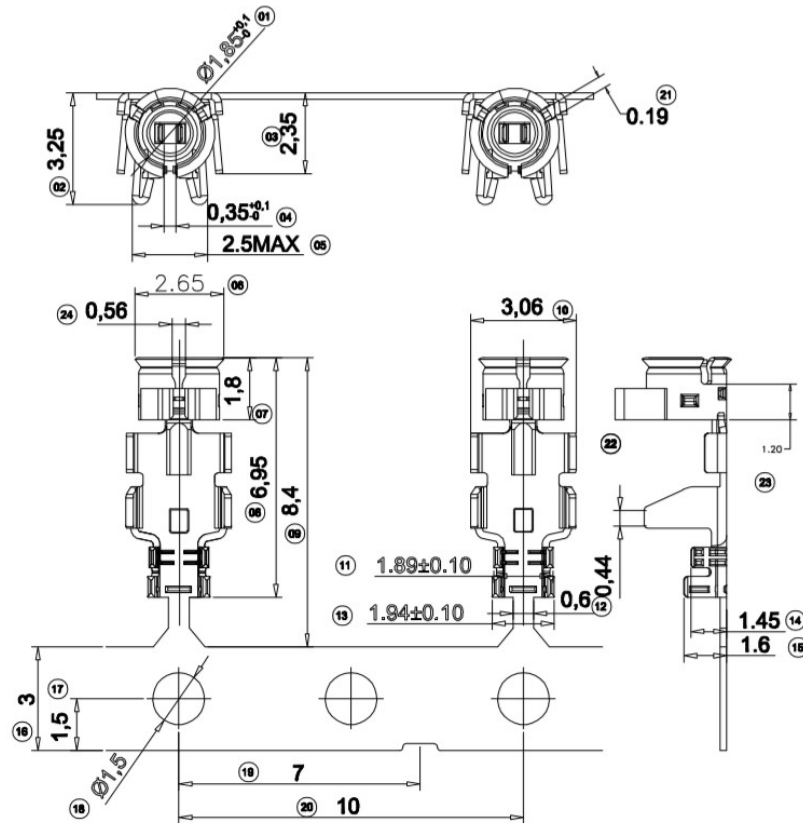

NOTE:

1. 塑胶材料: 热塑性塑胶;
HOUSING MATERIAL: THERMOPLASTIC PLASTIC, UL 94V-0;
端子材料: 铜合金, 表面镀金1.0-1.5μ;
CONTACT MATERIAL: COPPER ALLOY, GOLD PLATED 1.0-1.5μ;
外壳材料: 铜合金, 表面镀金1.0-1.5μ;
SHELL MATERIAL: COPPER ALLOY, GOLD PLATED 1.0-1.5μ;
2. 产品性能:
PERFORMANCE:
2.1. 接触阻抗: 中心导体20mΩ Max, 外壳10Ω Max.
CONTACT RESISTANCE: 20mΩ Max.
2.2. 耐电压: 200V AC, 1 Minute;
DIELECTRIC WITHSTANDING VOLTAGE: 200V AC FOR 1MINUTE;
2.3. 绝缘阻抗: 500MΩ Min.
INSULATION RESISTANCE: 500MΩ Min.
2.4. 插拔耐久性: 30次 Min.
DURABILITY: 30TIMES Min.
2.5. VSWR 1.5max at 0.1GHz-3GHz; 1.5max at 3GHz-6GHz
驻波比 在 0.1GHz-3GHz 之间, 驻波比最大1.3;
在 3GHz-6GHz 之间, 驻波比最大 1.5.
2.6. SALT SPRAY 5±1% SALT CONCENTRATION 48±4 HOURS 35±2°C
盐雾要求 盐水浓度 (重量比) 5±1%, 时间 48 小时
3. 技术要求:
TECHNICAL REQUIREMENT:
3.1. 特性阻抗: 50±3Ω;
CHARACTERISTIC IMPEDANCE: 50±3Ω

Shenzhen all things connected Communication Co.,Ltd.
All things connected Communications Xiangyang Limited
Add: Room 1101,Building 4,Fangdacheng,No2,longxhu 4th Road, Nanshan District, Shenzhen City
Add: Hubei Xiangyang Gucheng County 1-3 Shuang Yang Road Taoyuan Street,All things connected industrial park,

九、Reliability testing环境可靠性试验报告

1 Environmental experiment环境试验

High and low temperature and humidity test report						
test project	High temperature, low temperature and constant humidity test					
name	Built-in antenna (WWXL6010193)	date	2023.09.13			
device	Constant temperature and humidity test box network analyzer	Quantity	5PCS			
Inspectin standards	1. There are no defects such as peeling off, cracks, wrinkles, etc. on the metal surface; non-metal parts must not have defects such as discoloration, cracking, deformation, degumming. 2. The electrical test meets the design requirements; the voltage standing wave ratio test is satisfactory.					
Test name	Pilot projects	request	experiment method	Actual test data	result	
					sample	Assessment result
High temperature test	Temperature (°C)	+85±3	9 according to GB2423.1-89 Method	+87 1.2 2.3 1	1	qualified
	Test sample temperature stabilization time (H)				2	qualified
	Test duration (h)				3	qualified
	Recovery time (h)				4	qualified
					5	qualified
Low temperature test	Temperature (°C)	-45±3	8th in accordance with GB2423.1-89 Method	-46 1.2 2.4 1.1	1	qualified
	Test sample temperature stabilization time (h)				2	qualified
	Test duration (h)				3	qualified
	Recovery time (h)				4	qualified
					5	qualified
Constant Damp Heat Test	Temperature (°C)	+40±2 90-95 21	According to GB2423.3-93 Section 5	+42 92 22	1	qualified
	Relative				2	qualified
					3	qualified

Shenzhen all things connected Communication Co.,Ltd.
 All things connected Communications Xiangyang Limited
 Add: Room 1101,Building 4,Fangdacheng,No2,longxhu 4th Road, Nanshan District, Shenzhen City
 Add: Hubei Xiangyang Gucheng County 1-3 Shuang Yang Road Taoyuan Street,All things connected industrial park,

	humidity (%)	1	Method	1.1	4	qualified
	Test duration (h) Recovery time (h)				5	qualified

b. Salt spray test

Salt fog test report				
Test item	Salt spray test			
Name	Built-in antenna (WWXL6010193)	date of observation	2023.09.13	
Device name	Salt spray corrosion test box	Test quantity	5 PCS	
Test method	The test samples were put into the modulated salt solution test chamber and salt spray corrosion chamber for continuous spray test			
Salt solution concentration	52g/L	PH Value of Salt Solution: 6.5-7.2	Test cycle: 24h	
Actual test data	55g/L	PH Value of Salt Solution: 6.8	Test cycle: 26h	
Test standard	Tests were carried out according to GB/T10125 "Artificial Atmosphere Corrosion Test and Salt Spray Test"; Results According to GB/T6461-2002 "Metal and other inorganic coatings on metal substrates after corrosion test are samples and specimens"			
Test result				
NO	Corrosion resistance grade	Actual test data	Assessment result	Remarks
1	Rp/Ra=10/10vsB	Rp/Ra=10/10vsB	qualified	
2	Rp/Ra=10/10vsB	Rp/Ra=10/10vsB	qualified	
3	Rp/Ra=10/10vsB	Rp/Ra=10/10vsB	qualified	
4	Rp/Ra=10/10vsB	Rp/Ra=10/10vsB	qualified	
5	Rp/Ra=10/10vsB	Rp/Ra=10/10vsB	qualified	

Shenzhen all things connected Communication Co.,Ltd.
 All things connected Communications Xiangyang Limited
 Add: Room 1101,Building 4,Fangdacheng,No2,longxhu 4th Road, Nanshan District, Shenzhen City
 Add: Hubei Xiangyang Gucheng County 1-3 Shuang Yang Road Taoyuan Street,All things connected industrial park,

3. Tensile test

拉力测试报告 (Test Report)							
样品名称 (Product name)	ANT00210-1A	样品型号 (Part Model)	WWXL6010193	环境温度 (Ambient temperature)	20±5℃	测试日期 (Date of test)	2023.09.13
样品数量 (Specimens quantity)	3PCS	客户料号 (Customer number)	360100425	相对湿度 (Relative humidity)	50-60%RH	委托单位 (Client/Dept)	品质部 (Quality Department)
测试原因 (Test reasons)	<input checked="" type="checkbox"/> 新型号材料验证 New model material verification <input type="checkbox"/> 新工艺验证 New Process Verification <input type="checkbox"/> ORT测试 ORT test <input type="checkbox"/> 过期物料 Expired materials <input type="checkbox"/> 客户投诉/要求 Customer Complaints/requests <input type="checkbox"/> 高不良率 High non-performing rate <input type="checkbox"/> 其他: Others:			测试依据 (Test documentation)	<input type="checkbox"/> 产品图纸 Product drawings <input checked="" type="checkbox"/> 天线可靠性检验基准书 Antenna reliability test reference book <input type="checkbox"/> 客户要求 Customer requirements <input type="checkbox"/> 出货检验基准书 Shipping inspection reference book <input type="checkbox"/> 其他: Others:		
测试项目: (Test project)	拉力测试 Tensile test						
测试条件: (Test condition)	1. 01.13线径端子拉力大于1kgf 端子脱落后表盘数据大于1kgf The tensile force of 01.13 wire diameter terminal is greater than that of 1kgf The dial data is greater than 1KGF after the terminal is dropped 2. 测试频率: 保持2S Test frequency: Hold 2s						
测试要求 (Test note)	要求: 端子脱落后表盘数据大于1kgf Requirement: dial data greater than 1kgf after terminal dropping						
试验设备 (Test equipment)	设备名称 The name of the device	设备型号 Type of equipment	校验日期 Check date	下次校验日期 Date of next check			
	数显式推拉力计 Digital display push-pull force meter	H5001809695	2023.01.4	2024.01.3			
测试图片 (Test picture)	1. 试验过程图片 Experiment Process Picture 						
试验结果 (Test result)	实验后端子拉力: 1.88kgf 2.15kgf 1.44kgf 拉力大于1kgf 则合格 After the experiment, the terminal tension was 1.88 KGF, 2.15 KGF, 1.44 KGF If the tensile force is greater than 1 kgf, it is qualified						
最终判定 (final result)	<input checked="" type="checkbox"/> 合格 Qualified <input type="checkbox"/> 不合格 Disqualified						
备注 (comments):							
测试 (Name of operator):	孙毅 Sun Yi	审核 (Checked by):	唐勇	核准 (Approved by):	董晓燕 Tong Xiaoyan		

Shenzhen all things connected Communication Co.,Ltd.
 All things connected Communications Xiangyang Limited
 Add: Room 1101,Building 4,Fangdacheng,No2,longxhu 4th Road, Nanshan District, Shenzhen City
 Add: Hubei Xiangyang Gucheng County 1-3 Shuang Yang Road Taoyuan Street,All things connected industrial park,

十、Packing instructions 包装说明:

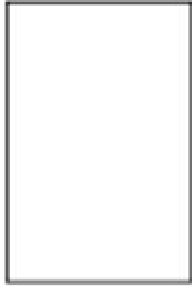

100PCS/Pouch

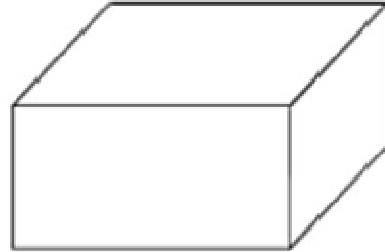

30Pouch/1Caron

Shenzhen all things connected Communication Co.,Ltd.
All things connected Communications Xiangyang Limited
Add: Room 1101,Building 4,Fangdacheng,No2,longxhu 4th Road, Nanshan District, Shenzhen City
Add: Hubei Xiangyang Gucheng County 1-3 Shuang Yang Road Taoyuan Street,All things connected industrial park,