

Programmable Universal Tire-Pressure Sensor (With Adjustable Valve Stem)

TS101 Universal Tire-Pressure Sensor User Manual (Metal Valve / Clamp-in Style)

Disclaimer

Please read this manual carefully before installing TS101 universal tire sensor (hereinafter referred to as TS101). For safety reasons, all the installation and maintenance operations should be carried out by trained professionals, with the guidance of vehicle manufacturer. Tire valves are vehicle-safety related component and incorrect installations may cause malfunctions for tire valves or TPMS sensors. Shenzhen Xtooltech Intelligent Co., Ltd. (hereinafter referred to as "Xtooltech") does not assume any liability in case of incorrect installation of the product. Pictures illustrated here are for reference only and this user manual is subject to change without prior notice.

Warranty

TS101 sensor is guaranteed to be free from material or manufacturing defects for a period of 24 months or 40,000km (25,000 miles), whichever comes first. In case of defections caused by material or workmanship, Xtooltech will repair or replace (according to the situations) the product or parts for free by inspecting the proof of purchase.

Xtooltech are not responsible for defects caused in the following circumstances:

- Incorrect installation;
- Irregular usage;
- Damage caused by collision or tire damage;
- Exceeding specific using limits of the product.

Exploded View

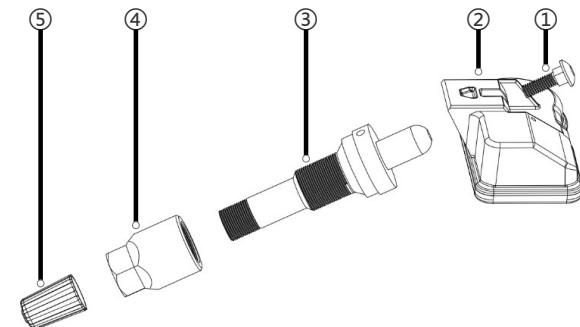

- 1 Screw
- 2 Sensor
- 3 Valve stem, Rubber Washer & Valve Core Assembly
- 4 Valve Nut & Washer
- 5 Valve Cap

Warning

- Make sure the sensor has already been programmed before use. We strongly recommend to program the sensor before installing tires.
- Do not install a programmed TS101 sensor inside a broken wheel.
- To ensure the best performance, do not install valve stems from other manufacturers, or install other parts which is not included inside TS101 sensor.
- After finished installation, please test the TPMS system according to the guidance inside user manual from the original vehicle manufacturer, in order to confirm that the sensor is installed correctly.
- When the tire is removed, it is highly recommended to replace or service the sensor. If the tire is using rubber valve, the valve stem must be replaced.
- When driving vehicles with TS101 installed, the speed should be under 240km/h (150mph) and the tire pressure should be no higher than 900 kPa (9.0 bar or 130.5 psi).

Contact Us

- Official Website: www.xtooltech.com
- Service Hotline: +86 0755-21670995
+86 0755-86267858
- E-mail Address: supporting@xtooltech.com
aftersales-services@xtooltech.com

Specifications

Sensor Weight (valve not included)	approx. 13 g
Dimensions (valve not included)	46.1 x 25 x 16.2mm (1.81" x 0.98" x 0.64")
Max. Pressure	900 kPa (9.0 bar or 130.5 psi)
Max. Speed	240 km/h (150mph)

Installation Guide

- ⚠ Every time the tire been repaired, dismantled, or uninstalling & replacing TS101 sensors, make sure that the original rubber washer, screws, nuts and valve stems from TS101 are used in order to keep good air tightness. If the tire or wheel is damaged externally, the TS101 sensor must be replaced. The torque of the valve tightening screw should be 4Nm (2.95 lb · ft).

1. Deflate & Uninstall Tire

Take off the valve cap and the valve core to deflate the tire. Then, use tools (or machines) to uninstall the tire from the rim.

*In case of replacing the sensor only, deflate the tires, pry up the tire near valve stem until the sensor is exposed. Do not break the tire bead near the valve stem, or the original sensor may get damaged.

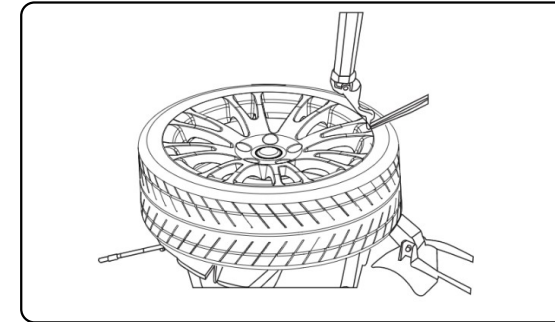

2. Uninstall Sensor

Take off the valve nut, washer and screw from the valve stem. Then, take the sensor assembly out from the rim.

* Here shows the process of uninstalling TS101 sensor. If you have problems when uninstalling other sensors, please check the repair manual or installation guide for uninstalling steps.

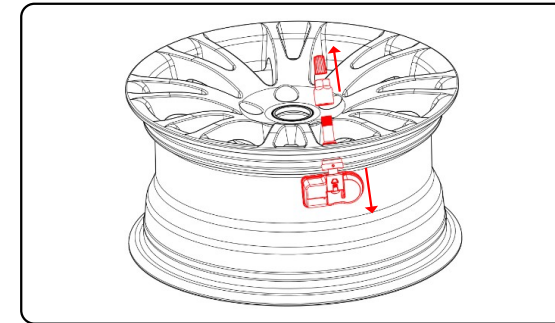

3. Install TS101 Sensor

- ① Use the screw to assembly the valve core and the TS101 sensor tightly.
- ② Uninstall the valve nut, washer and valve cap.
- ③ Adjust the angle of the sensor, then insert the valve core inside the valve hole, and make sure that the TS101 sensor is inside the rim.
- ④ Install the valve nut and washer back to the valve core.
- ⑤ Lock the nut with 4Nm (2.95 lb · ft) of torque.
- ⑥ Install the tire back, inflate the tire to standard tire pressure (see vehicle nameplate) and install the valve cap.

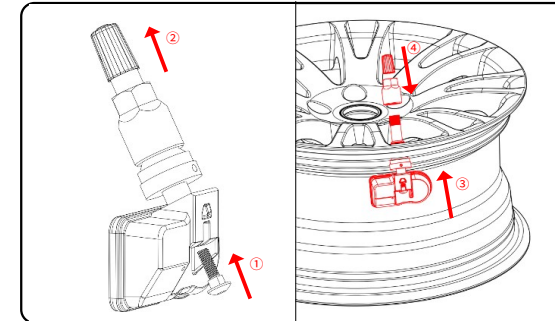

Shenzhen Xtooltech Intelligent Co., Ltd.

Address: 17&18/F, A2 Building, Creative City, Liuxian Avenue, Nanshan District, Shenzhen, China
For cooperation or business inquiry, please contact: marketing@xtooltech.com

FCC Statement

This equipment has been tested and found to comply with the limits for a Class B digital device, pursuant to part 15 of the FCC Rules. These limits are designed to provide reasonable protection against harmful interference in a residential installation. This equipment generates, uses and can radiate radio frequency energy and, if not installed and used in accordance with the instructions, may cause harmful interference to radio communications. However, there is no guarantee that interference will not occur in a particular installation. If this equipment does cause harmful interference to radio or television reception, which can be determined by turning the equipment off and on, the user is encouraged to try to correct the interference by one or more of the following measures:

- Reorient or relocate the receiving antenna.
- Increase the separation between the equipment and receiver.
- Connect the equipment into an outlet on a circuit different from that to which the receiver is connected.
- Consult the dealer or an experienced radio/TV technician for help.

Caution: Any changes or modifications to this device not explicitly approved by manufacturer could void your authority to operate this equipment.

This device complies with part 15 of the FCC Rules. Operation is subject to the following two conditions: (1) This device may not cause harmful interference, and (2) this device must accept any interference received, including interference that may cause undesired operation.

RF Exposure Information

The device has been evaluated to meet general RF exposure requirement. The device can be used in 0mm exposure condition, compliance with exposure requirements.