

**TEST RESULTS (Cont):**

Middle Channel 99% Occupied Bandwidth

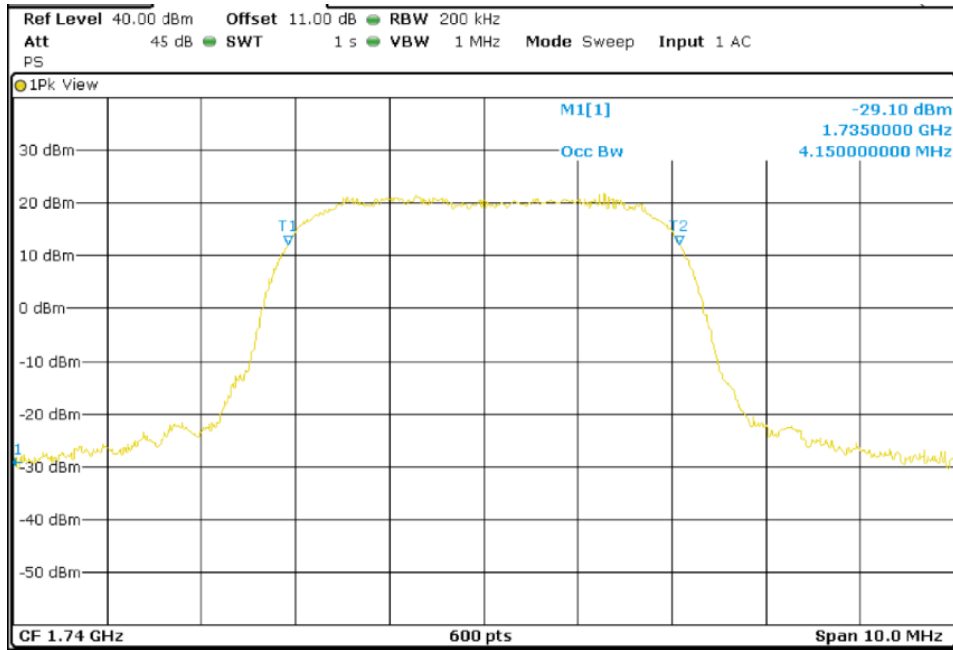

Middle Channel 26dBc Bandwidth kHz

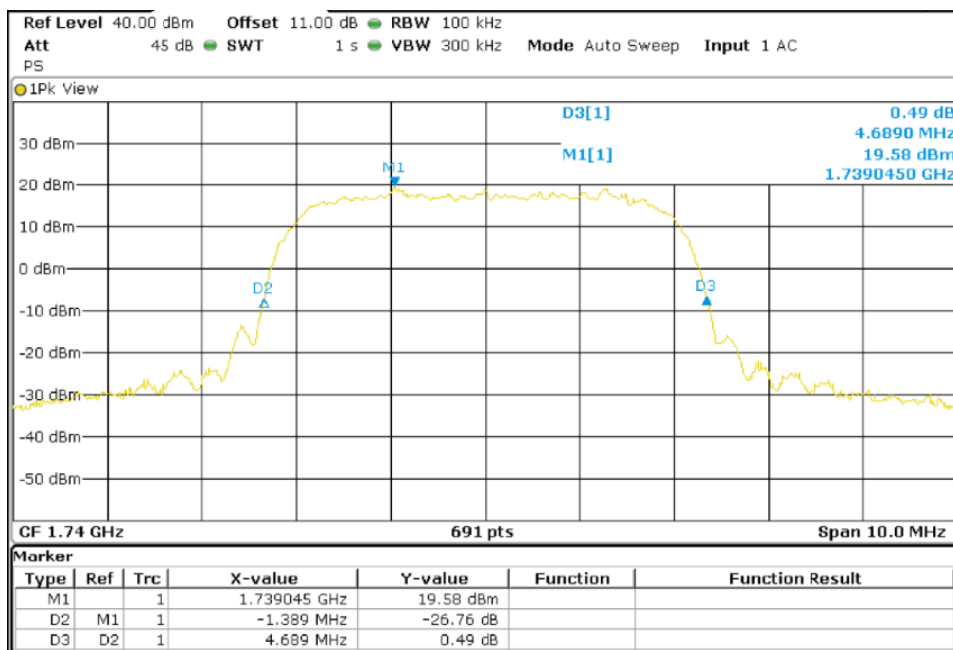

**TEST RESULTS (Cont):**

Highest Channel 99% Occupied Bandwidth

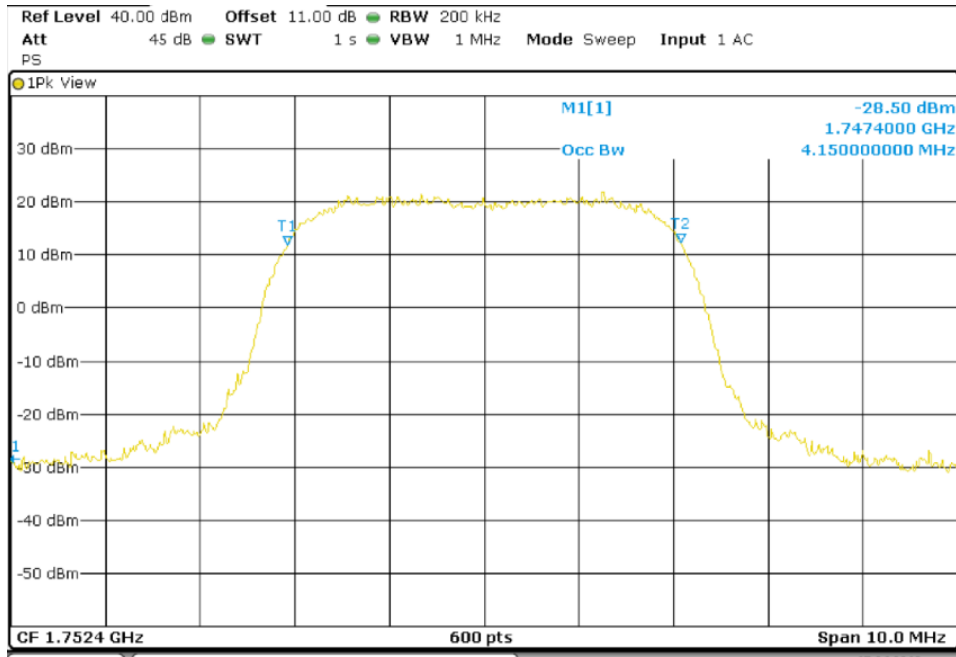

Highest Channel 26dBc Bandwidth kHz

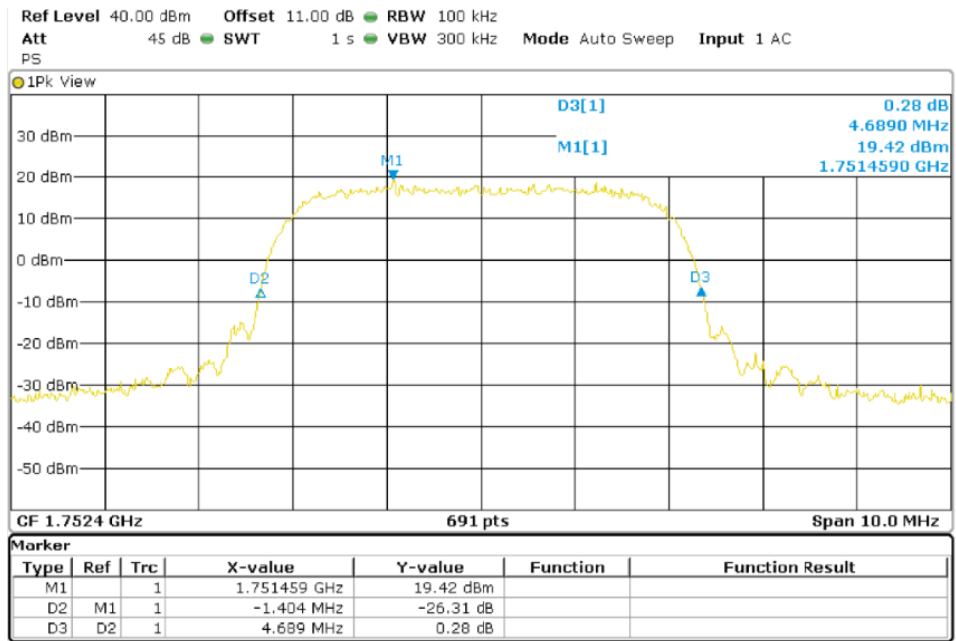

## TEST B.5: SPURIOUS EMISSIONS AT ANTENNA TERMINALS

<b>LIMITS:</b>	Product standard:	FCC Part 27 / IC RSS-139
	Test standard:	FCC §2.1051 and § 27.53 / RSS-139 Clause 6.6

### LIMITS

According to specification, the power of emissions shall be attenuated below the transmitter power (P) by a factor of at least  $43 + 10 \log (P)$  dB. P in watts.

At  $P_o$  transmitting power of 2 watts (33 dBm), the specified minimum attenuation becomes  $43 + 10 \log (P_o)$ , and the level in dBm relative to  $P_o$  becomes:

$$P_o \text{ (dBm)} - [43 + 10 \log (P_o \text{ in watts})] = -13 \text{ dBm}$$

### TEST SETUP

The EUT RF output connector was connected to a spectrum analyzer and to the Universal Radio Communication Tester R&S CMW500 (selecting maximum transmission power of the EUT and different modes of modulation) using a 50-ohm attenuator and a power splitter.

The reading of the spectrum analyzer is corrected with the attenuation loss of connection between output terminal of EUT and input of the spectrum analyzer.

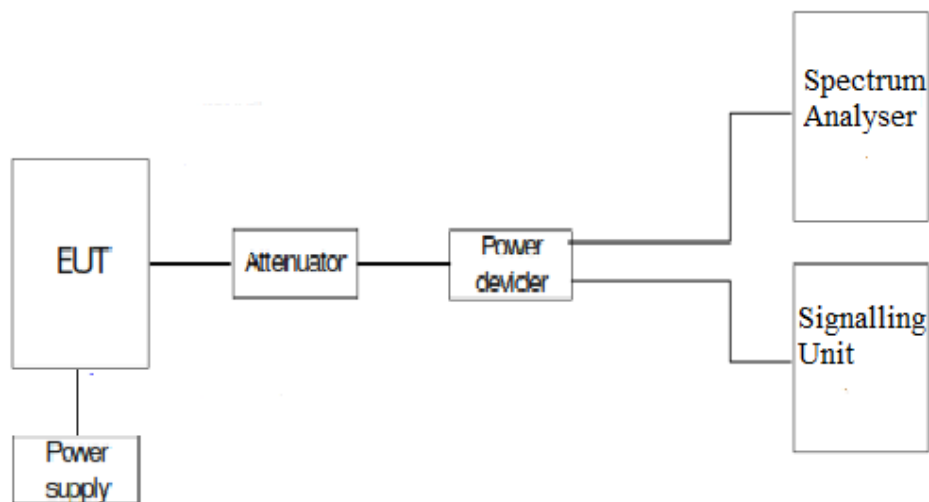

<b>TESTED SAMPLES:</b>	S/01
<b>TESTED CONDITIONS MODES:</b>	TC#01
<b>TEST RESULTS:</b>	PASS

Frequency range 9 KHz – 26 GHz

WCDMA MODULATION.

Lowest Channel

Spurious frequency (MHz)	Level (dBm)	Measurement uncertainty (dB)
2112.84	-30.32	< ± 1.20

Middle Channel

Spurious frequency (MHz)	Level (dBm)	Measurement uncertainty (dB)
2140.46	-30.73	< ± 1.20

Highest Channel

Spurious frequency (MHz)	Level (dBm)	Measurement uncertainty (dB)
2154.28	-30.95	< ± 1.20

**TEST RESULTS (Cont.):**

WCDMA MODULATION.

Lowest Channel

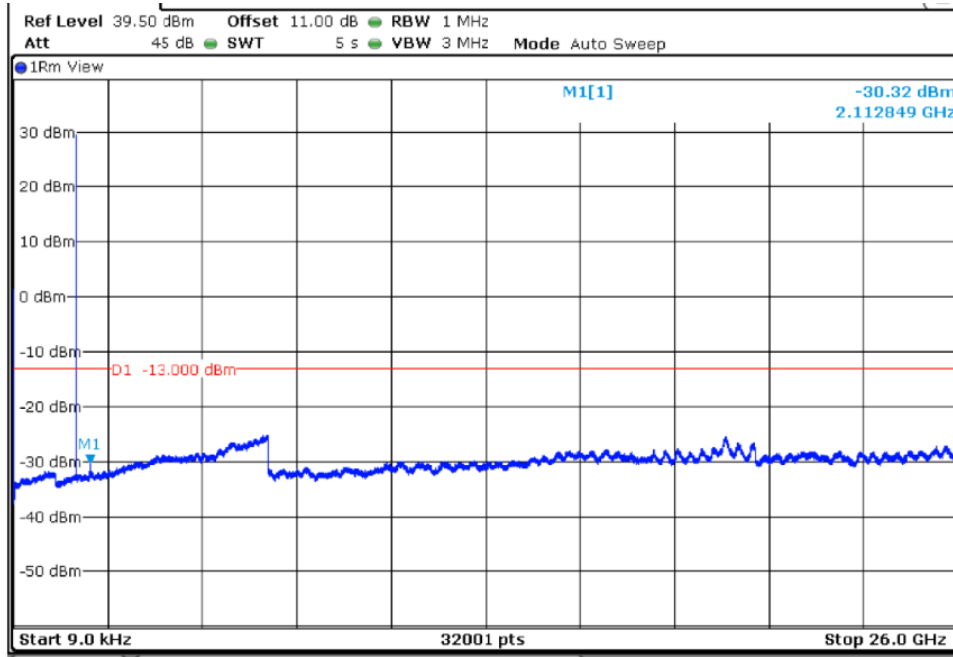

Middle Channel

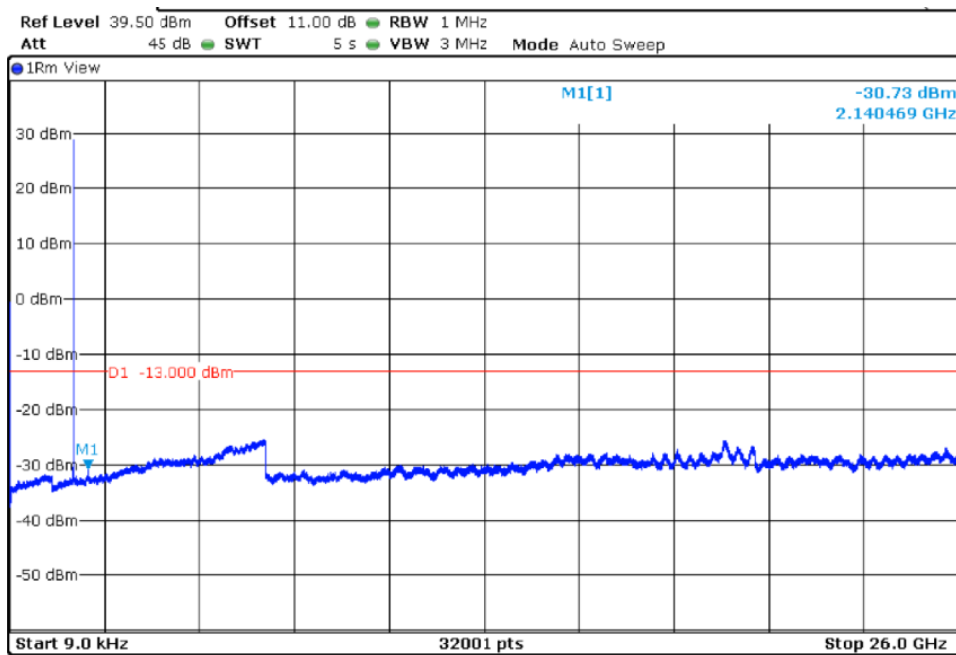

### TEST RESULTS (Cont):

Highest Channel

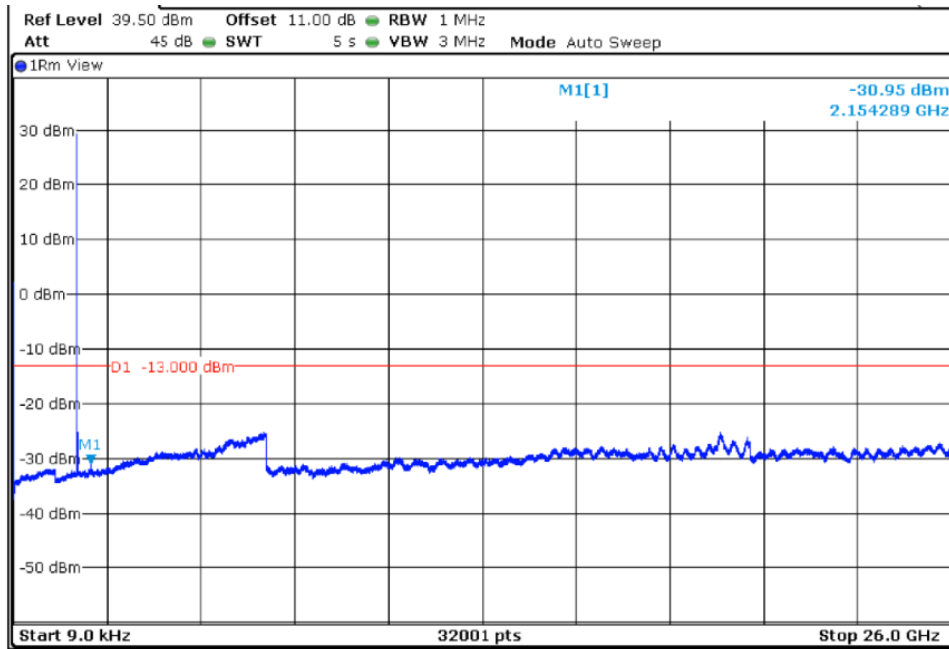

## TEST B.6: SPURIOUS EMISSIONS AT ANTENNA TERMINALS AT BLOCK EDGES

<b>LIMITS:</b>	Product standard:	FCC Part 27 / IC RSS-139
	Test standard:	FCC § 27.53 / RSS- Clause 6.6

### LIMITS

According to specification, the power of emissions shall be attenuated below the transmitter power (P) by a factor of at least  $43 + 10 \log (P)$  dB. P in watts.

At  $P_o$  transmitting power of 2 watts (33 dBm), the specified minimum attenuation becomes  $43 + 10 \log (P_o)$ , and the level in dBm relative to  $P_o$  becomes:

$$P_o \text{ (dBm)} - [43 + 10 \log (P_o \text{ in watts})] = -13 \text{ dBm}$$

### TEST SETUP

The EUT RF output connector was connected to a spectrum analyzer and to the Universal Radio Communication Tester R&S CMW500 (selecting maximum transmission power of the EUT and different modes of modulation) using a 50-ohm attenuator and a power splitter.

The reading of the spectrum analyzer is corrected with the attenuation loss of connection between output terminal of EUT and input of the spectrum analyzer.

For LTE mode the configuration of modulation which is the worst case for conducted power was used.

As indicated in FCC part 27, in the 1 MHz bands immediately outside and adjacent to the licensee's frequency block or band, a resolution bandwidth of at least one percent of the emission bandwidth of the fundamental emission of the transmitter may be employed.

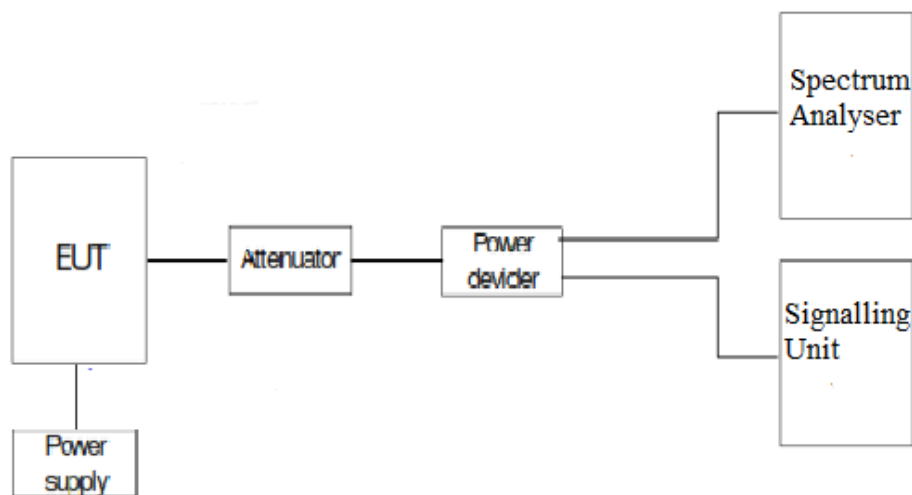

<b>TESTED SAMPLES:</b>	S/01
<b>TESTED CONDITIONS MODES:</b>	TC#01
<b>TEST RESULTS:</b>	PASS

WCDMA MODULATION	Low Channel	High Channel
Maximum measured level at lowest and Highest Block Edge at antenna port (dBm)	-29.78	-32.96



**TEST RESULTS (Cont):**

WCDMA MODULATION.

Lowest Channel

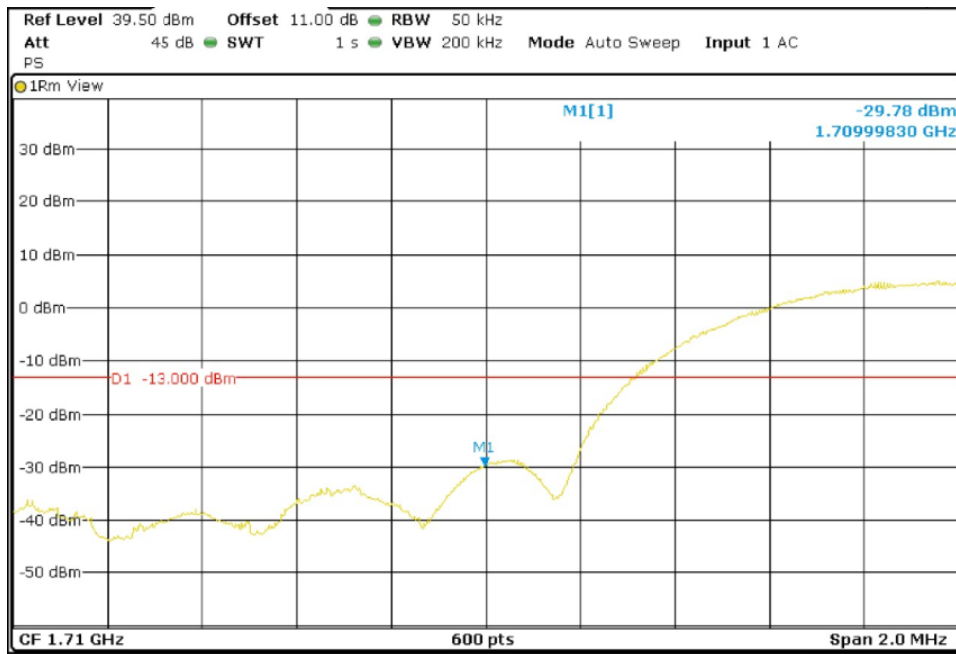

Highest Channel

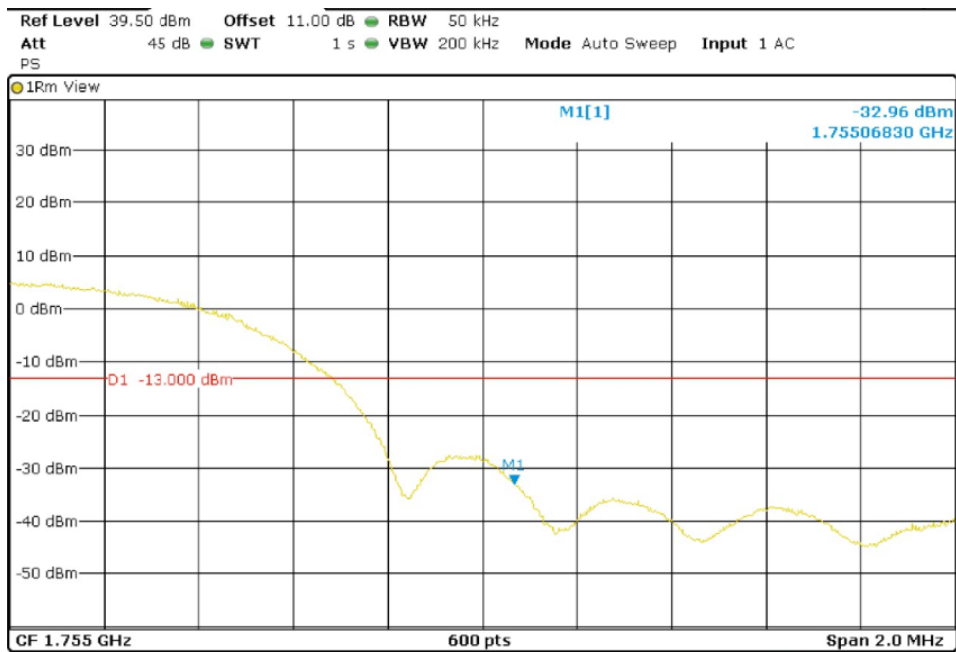

## TEST B.7: RADIATED EMISSIONS

<b>LIMITS:</b>	Product standard:	FCC Part 27 / IC RSS-139
	Test standard:	FCC §2.1053 and §27.53 / RSS-139 Clause 6.6

### LIMITS

According to specification, the power of emissions shall be attenuated below the transmitter power (P) by a factor of at least  $43 + 10 \log(P)$  dB. P in watts.

At  $P_o$  transmitting power of 2 watts (33 dBm), the specified minimum attenuation becomes  $43 + 10 \log(P_o)$ , and the level in dBm relative to  $P_o$  becomes:

$$P_o \text{ (dBm)} - [43 + 10 \log(P_o \text{ in watts})] = -13 \text{ dBm}$$

### TEST SETUP

The measurement was performed with the EUT inside an anechoic chamber. The spectrum was scanned from 30 MHz to at least the 10th harmonic of the highest frequency generated within the equipment.

The EUT was placed on a non-conductive stand at a 3-meter distance from the measuring antenna for measurements below 1 GHz and at 1-meter distance for measurements above 1 GHz.

Detected emissions were maximized at each frequency by rotating the EUT and adjusting the measuring antenna height and polarization. The maximum reading was recorded.

#### Radiated measurements < 1GHz

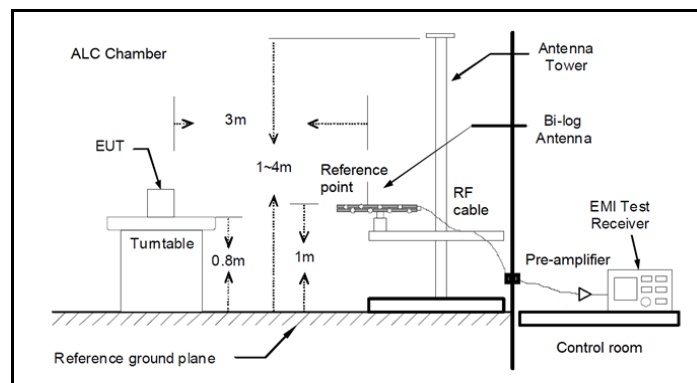

#### Radiated measurements > 1GHz

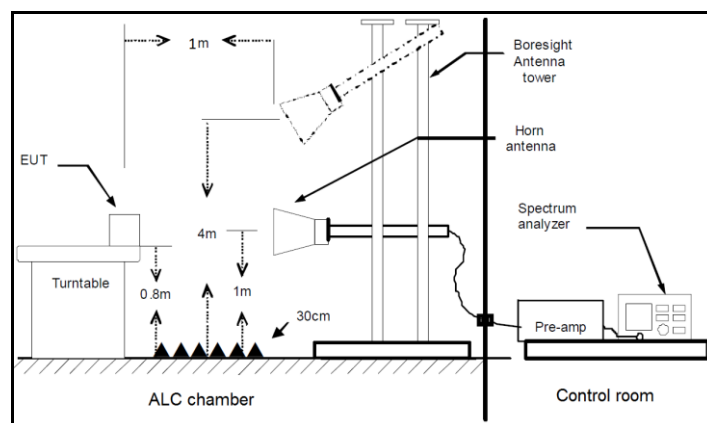

<b>TESTED SAMPLES:</b>	S/01
<b>TESTED CONDITIONS MODES:</b>	TC#01
<b>TEST RESULTS:</b>	PASS

A preliminary scan determined the WCDMA Modulation as the worst case. The following plots show the results for this configuration.

<b>TEST RESULTS (Cont):</b>	Low Channel
-----------------------------	-------------

FREQUENCY RANGE: 30-1000 MHz

### Maximizations

Frequency (MHz)	PK+ _CLRWR (dBm)	PK+ _MAXH (dBm)	Comment
30.129333	-62.78	-59.49	
146.367667	-70.42	-64.21	Fundamental
704.958333	-54.99	-52.01	

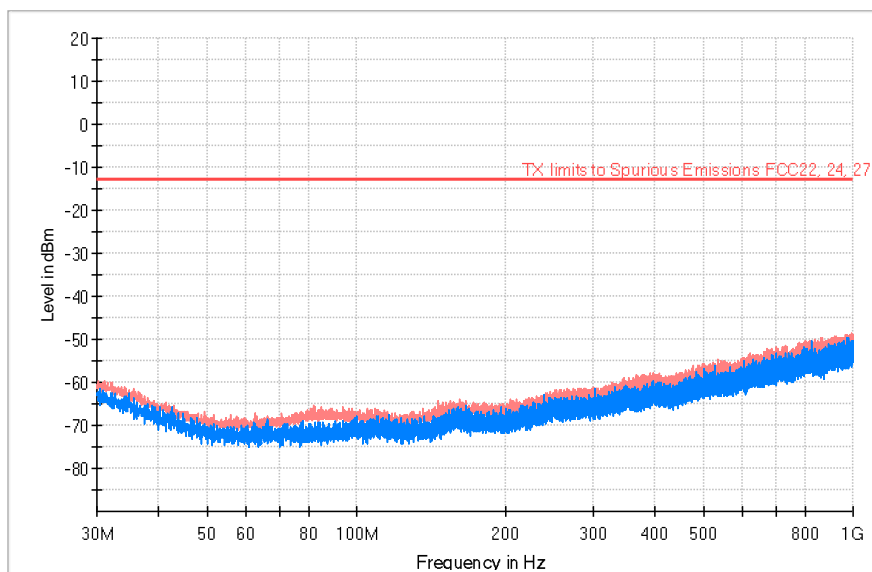

— PK+ \_MAXH — PK+ \_CLRWR — TX limits to Spurious Emissions FCC22, 24, 27

**TEST RESULTS (Cont):**

Low Channel

FREQUENCY RANGE: 1-18 GHz

Frequency (MHz)	PK+ CLRWR (dBm)	PK+ MAXH (dBm)	Comment
1718.666667	14.29	22.62	Fundamental
6223.500000	-44.69	-38.73	
13393.000000	-46.38	-40.40	

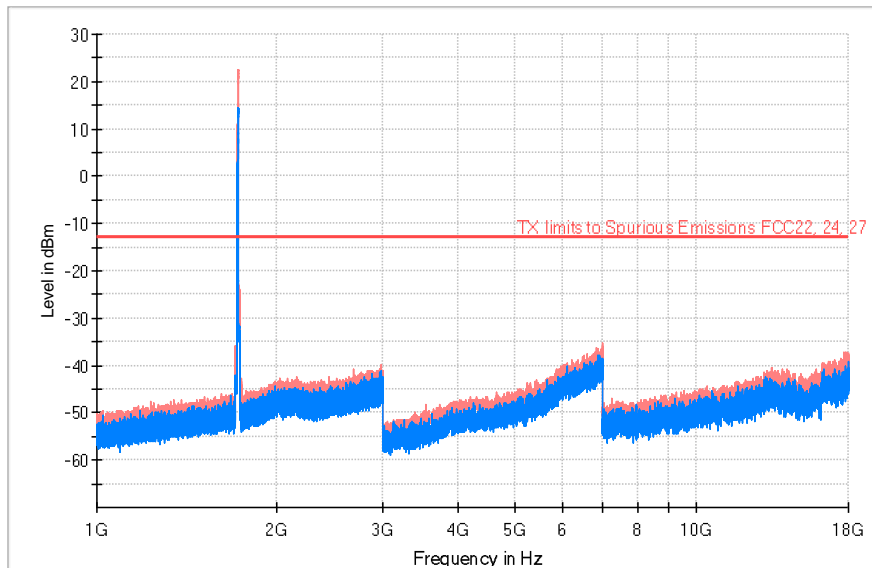

— PK+\_MAXH    — PK+\_CLRWR    — TX limits to Spurious Emissions FCC22, 24, 27

**TEST RESULTS (Cont):**

Mid Channel

**FREQUENCY RANGE: 30MHz -1 GHz**

**Maximizations**

Frequency (MHz)	PK+_CLRWR (dBm)	PK+_MAXH (dBm)	Comment
30.776000	-63.88	-59.04	
507.434000	-60.78	-54.58	
994.665000	-55.27	-48.73	Fundamental

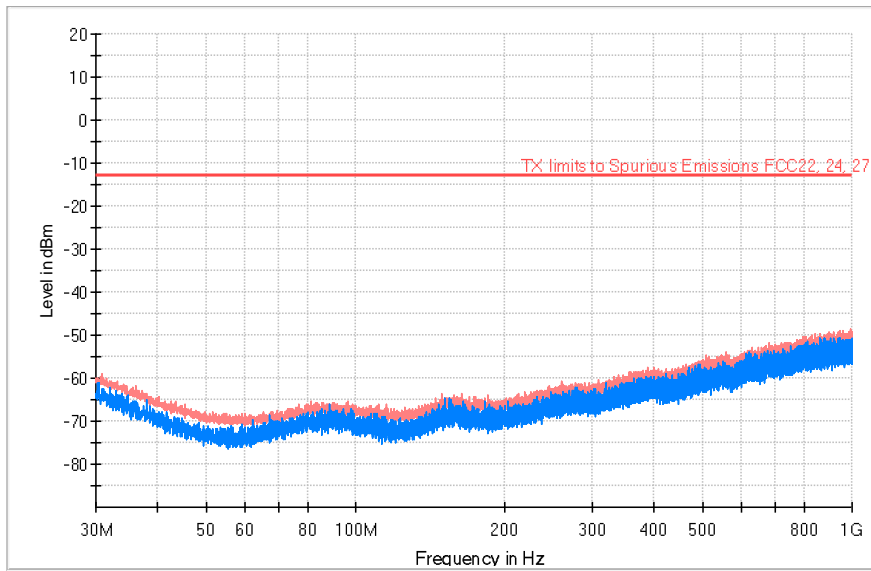

— PK+\_MAXH    — PK+\_CLRWR    — TX limits to Spurious Emissions FCC22, 24, 27

**TEST RESULTS (Cont):**

Mid Channel

**FREQUENCY RANGE: 1-18 GHz**

Frequency (MHz)	PK+ _CLRWR (dBm)	PK+ _MAXH (dBm)	Comment
1733.666667	15.56	22.94	Fundamental
7443.500000	-51.60	-46.58	
14598.500000	-46.48	-40.46	

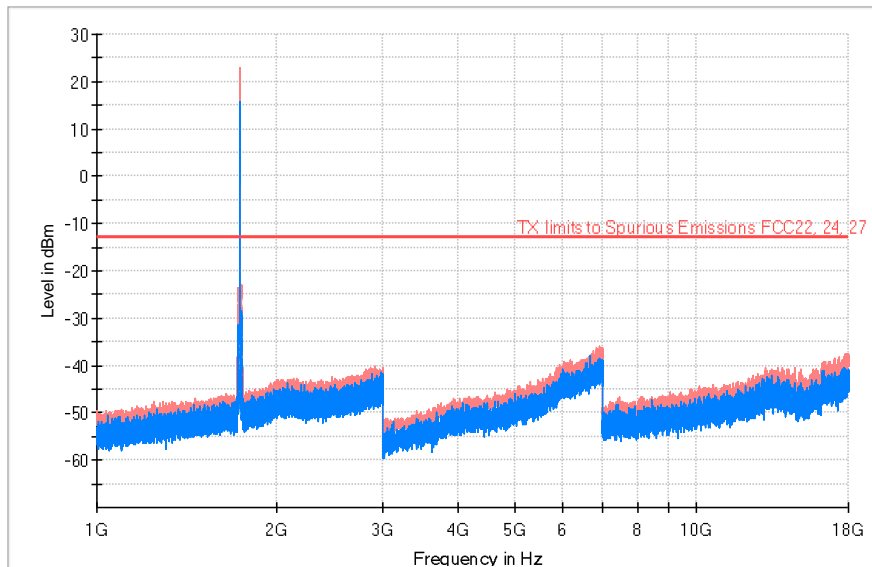

— PK+ \_MAXH    — PK+ \_CLRWR    — TX limits to Spurious Emissions FCC22, 24, 27

**TEST RESULTS (Cont):**

High Channel

FREQUENCY RANGE: 30MHz-1 GHz

Frequency (MHz)	PK+ _CLRWR (dBm)	PK+ _MAXH (dBm)	Comment
667.096000	-58.37	-51.79	
788.895667	-57.12	-49.91	Fundamental
994.762000	-53.70	-48.14	

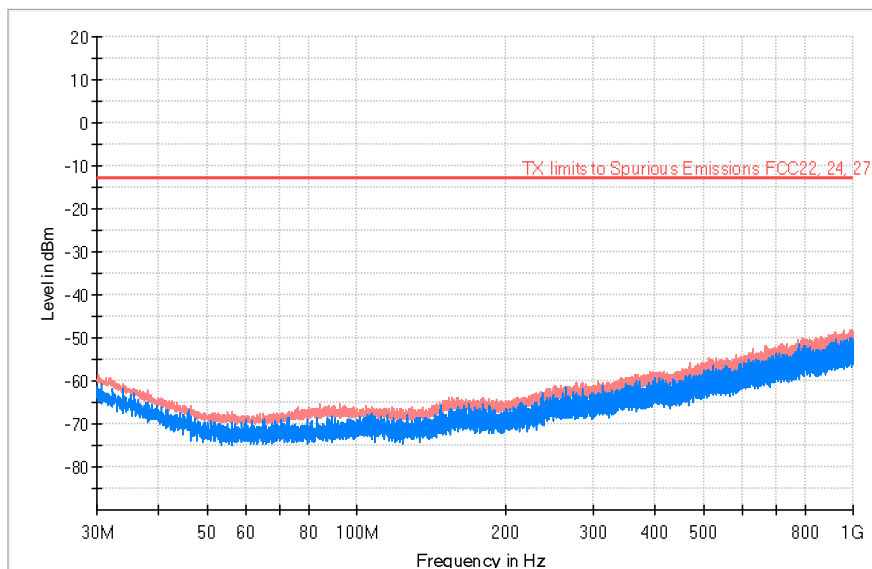

— PK+ \_MAXH    — PK+ \_CLRWR    — TX limits to Spurious Emissions FCC22, 24, 27

**TEST RESULTS(Cont.):**

High Channel

FREQUENCY RANGE: 1-18 GHz

Frequency (MHz)	PK+ _CLRWR (dBm)	PK+ _MAXH (dBm)	Comment
1743.866667	15.11	22.48	Fundamental
6845.500000	-42.27	-35.11	

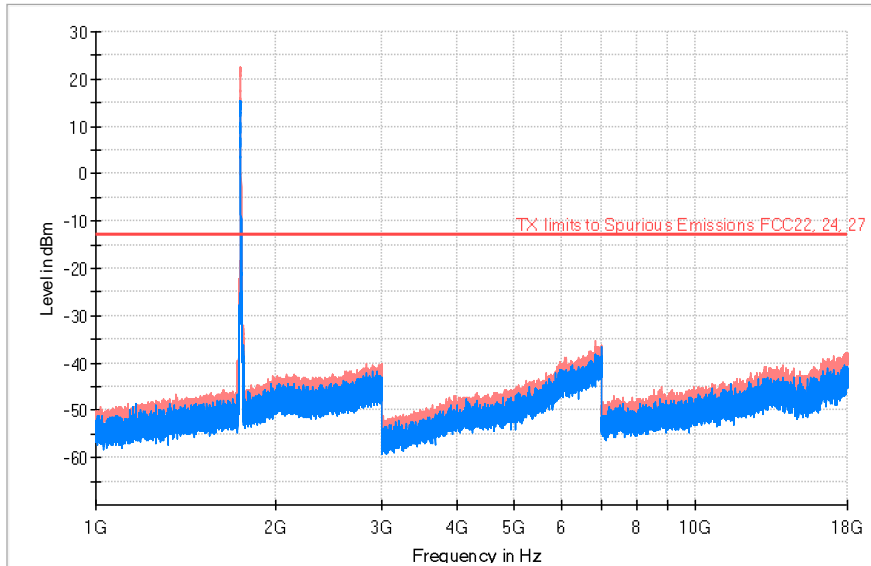

— PK+ \_MAXH    — PK+ \_CLRWR    — TX limits to Spurious Emissions FCC22, 24, 27