

FLEET AC DISPENSER WITH 18 FT CABLE

Installation Guide

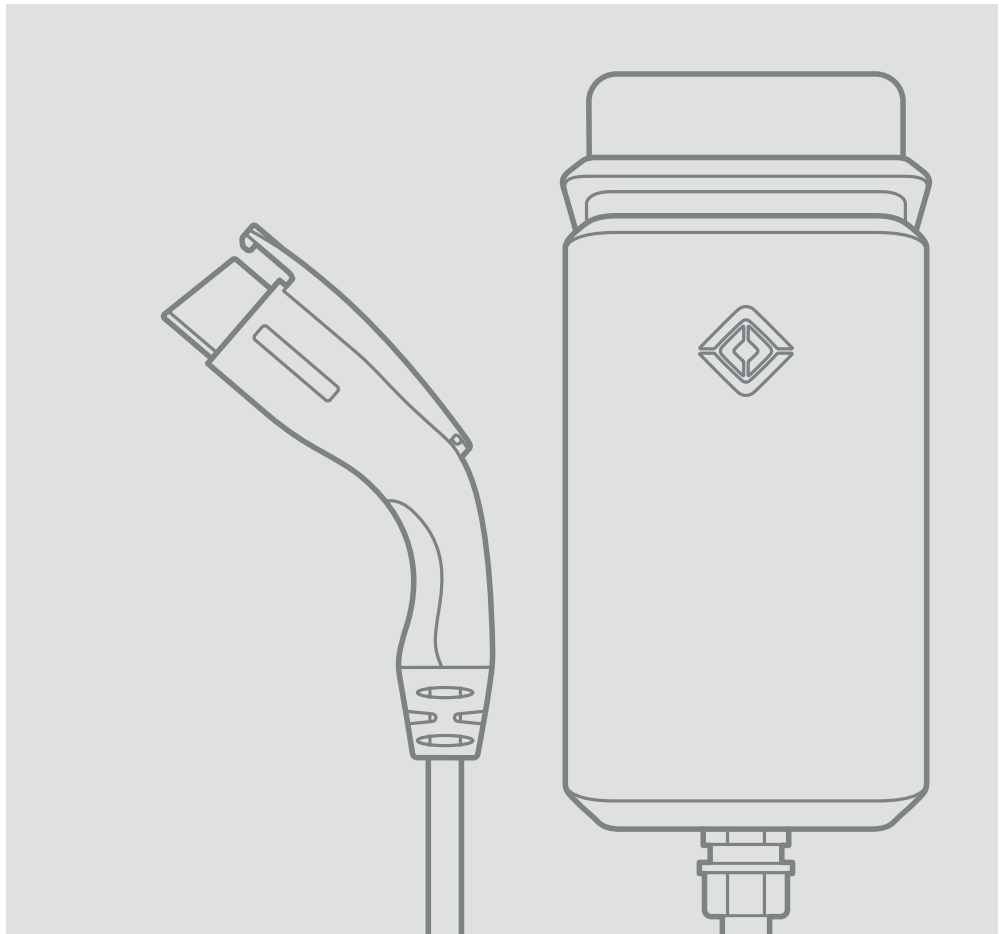

PRODUCT NUMBER PT00401761



© 2021-2022 Rivian Automotive, LLC. All rights reserved.

All information in this document and all Rivian software is subject to copyright and other intellectual property rights of Rivian Automotive, LLC, its affiliates, or its licensors. This material may not be modified, reproduced, or copied, in whole or in part, without the prior written permission of Rivian Automotive, LLC, its affiliates, or its licensors. Unless indicated otherwise, all trademarks are owned and registered by Rivian Automotive, LLC, its affiliates, or its licensors in the United States and/or other countries. Please visit <https://www.rivian.com/legal/brand> for Rivian's trademarks and service marks.

Software embedded or accessed by the vehicle may utilize open source software. Please visit <https://www.rivian.com/legal/open-source> for more information.

Contents

Important Safety Instructions	4
SAVE THESE INSTRUCTIONS	4
Precautions	4
Safety Symbols on Hardware Labels	8
Introduction	9
Identify Parts	9
Tools and Equipment	10
Remove the Faceplate	11
Install the SIM Card	12
Install the Dispenser	12
On a Rivian Gantry	12
On a Rivian Pedestal	12
On a Wall	15
Set the Operating Current	23
Connect Conductors	24
Install the Faceplate	25
Wall Installation Only - Wrap and Dock the Cable	26
Complete the Installation	26
Light Bar States	27
Troubleshooting	28
Specifications	29
Supplemental Information for Electrical Service Wiring	31
240V Split-Phase System	31
208V Three-Phase Wye-Connected	32
240V Three-Phase Delta-Connected	33
FCC Interference Statement	34
RF Exposure Information	34
Industry Canada Statement	35
Radiation Exposure Statement	35
Déclaration d'exposition aux radiations	35
Customer Service	37

Important Safety Instructions

SAVE THESE INSTRUCTIONS



DANGER

Read all the instructions before installing the Rivian Fleet AC Dispenser. Follow the safety instructions and warnings in this guide when installing the Fleet AC Dispenser. Failure to do so may result in fire, electrical shock, serious injury, or death.

PRECAUTIONS

The following safety symbols are used in this document.



DANGER

Risk of electric shock



DANGER

Risk of personal injury



CAUTION

Risk of damage to equipment

Risk of Electrical Shock



DANGER

- Improper connection of the equipment grounding conductor can result in a risk of electric shock. Check with a qualified electrician or service person if you are in doubt as to whether the product is properly grounded.
- Do not touch live electrical parts. Incorrect connections may cause electric shock.



- No user serviceable parts inside. Refer servicing to qualified service personnel.
- Do not put fingers into the coupler.
- Do not use this equipment if the flexible power cord or cable is frayed, has broken insulation, or any other signs of damage.
- Do not use this equipment if the enclosure or the coupler is broken, cracked, open, or shows any other indication of damage.
- Do not allow unsupervised children in the area during installation of the Fleet AC Dispenser.
- Before connecting the Fleet AC Dispenser to a power supply, check that the power supply voltage and current rating corresponds with the power supply details shown on the product rating label.
- Use appropriate protection when connecting to a main switchboard.
- Ground the Fleet AC Dispenser through a permanent wiring system using the equipment grounding conductor.
- To reduce the risk of fire, connect only to a circuit provided with no more than 60 amperes maximum branch circuit over-current protection in accordance with the National Electrical Code, ANSI/NFPA 70, and the Canadian Electrical Code, Part I, C22.2.
- When a breaker smaller than 60 amperes is used, ensure that the conductor sizes used comply with the minimum sizes prescribed by national and local electrical codes and standards.

Risk of Personal Injury



DANGER

- Disconnect the power supply before installing or repairing the Fleet AC Dispenser. Failure to do so may result in physical injury or damage to the power supply system and the Fleet AC Dispenser.
- Keep any packing materials away from children. These materials are a potential source of danger, and can cause suffocation.
- Only a licensed electrician should perform this installation in accordance with the provisions of national electrical codes and standards.

Risk of Damage to Equipment









CAUTION

- Use anti-static gloves, wrist bands connected to ground, and insulated tools for installation and removal of the faceplate.
- Do not operate this equipment in temperatures outside its operating range of -30°C to +50°C (-22°F to +122°F).
- Store this equipment in a clean dry location between -40°C and +80°C (-40°F to +176°F).
- Do not use extender cables to increase the length of the charging cable.
- If this unit is installed outdoors, the components and fittings must be rated for outdoor installation. The outlet must be installed properly to maintain the proper NEMA rating of the enclosure.
- Avoid direct hand contact with components on the network board.
- For storage/shipping of the front panel or network board, use a bubble wrap bag with ESD (electrostatic discharge) protection.
- Rivian does not recommend using a GFCI breaker since the Fleet AC Dispenser has charging circuit interrupting device (CCID20) protection. Using a GFCI breaker in the panel can cause nuisance tripping. If local codes require a GFCI breaker for plug-in installation, Rivian recommends a hardwire installation.

SAFETY SYMBOLS ON HARDWARE LABELS

The following safety symbols may appear on labels located on hardware used in this installation.

	Risk of Electric Shock
	Danger
	Phase
	Equipment Ground
	Instruction Manual
	UL Logo

Introduction

This document provides installation instructions for the Fleet AC Dispenser with 18 ft cable on a Rivian pedestal, gantry, or wall.

Identify Parts

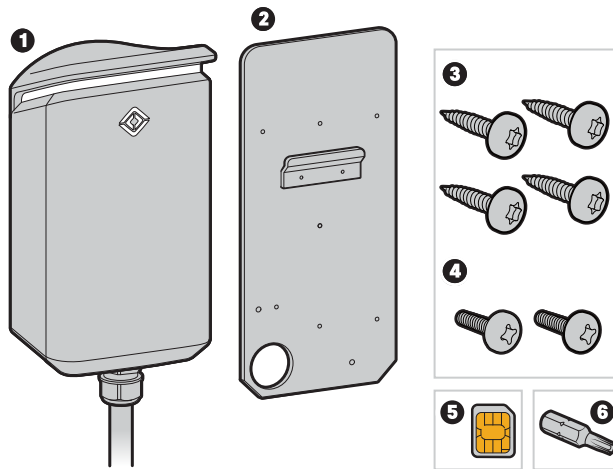

1. Fleet AC Dispenser
2. Mounting plate (wall installation only)
3. Four T20 anchor screws (wall installation only)
4. Two 13 mm M4 Phillips screws
5. Micro SIM (3FF) card
6. T20 Security bit

Tools and Equipment

Required	Optional (Wall Installation Only)
#2 Phillips screwdriver	Hole saw
Security T20 Torx screwdriver	Stud finder
Flathead screwdriver, 7/32 in width	Level
Adjustable torque screwdriver, 10 in-lb to 40 in-lb	
Multimeter	

Remove the Faceplate



CAUTION

- Use anti-static gloves, wrist bands connected to ground, and insulated tools for installation and removal of the faceplate.
- Avoid direct hand contact with components on the network board.

1. Remove the two Security T20 Torx screws on the bottom of the Fleet AC Dispenser.

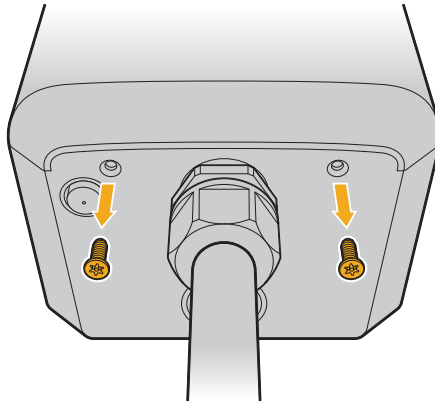

2. Push the faceplate up and remove it.

Install the SIM Card

1. Locate the SIM card socket on the interior of the faceplate.
2. Slide the SIM card socket cover upward and outward to open it.
3. Insert the Micro SIM (3FF) card into the socket.
4. Close the socket to lock it.

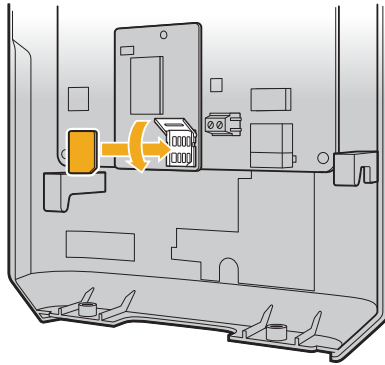

Install the Dispenser

- On a gantry (see below).
- On a pedestal (page 12).
- On a wall (page 15).

ON A RIVIAN GANTRY

Refer to the Rivian gantry installation guide for instructions on how to install the Fleet AC Dispenser on a Rivian gantry.

ON A RIVIAN PEDESTAL

NOTE

Before mounting the Fleet AC Dispenser, refer to the Rivian pedestal installation guide for instructions on how to install the pedestal.

Attach the Dispenser to the Pedestal

1. Remove the wire entry cover from the rear of the Fleet AC Dispenser by turning it counterclockwise.

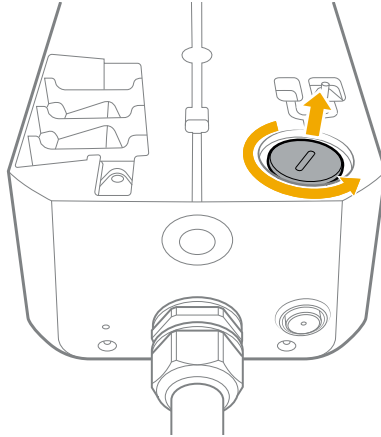

2. Hang the Fleet AC Dispenser on the mount hook located on the pedestal.

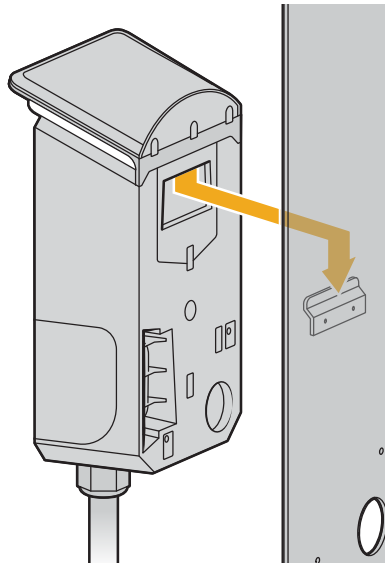

- Using a #2 Phillips screwdriver, install the two 13 mm long M4 screws through the interior of the Fleet AC Dispenser into the pedestal.

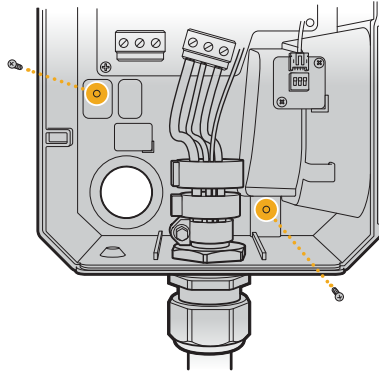

- Torque each screw to 12 in-lb (1.36 N·m).
- Place the cable plug in the dock on the pedestal.

ON A WALL

Select an Installation Location



CAUTION

- For indoor installations, install the Fleet AC Dispenser at least 18 in (45.7 cm) from the ground to bottom of dispenser.
- For outdoor installations, install the Fleet AC Dispenser at least 24 in (61 cm) from the ground to bottom of dispenser.

For ease of use, install the Fleet AC Dispenser around chest height, within easy cable reach of the vehicle charge port, and with at least 12 in (30.5 cm) of clearance on the right side to accommodate coupler docking and cable management.

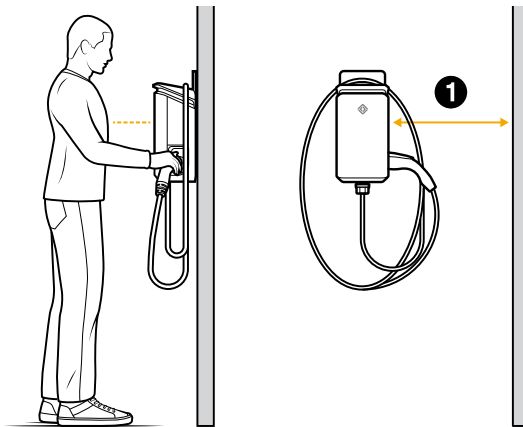

Item	Description
1	At least 12 in (30.5 cm)

Remove the Holster Cover Plate

Use a flathead screwdriver to pop the holster plate cover off of the side of the Fleet AC Dispenser.

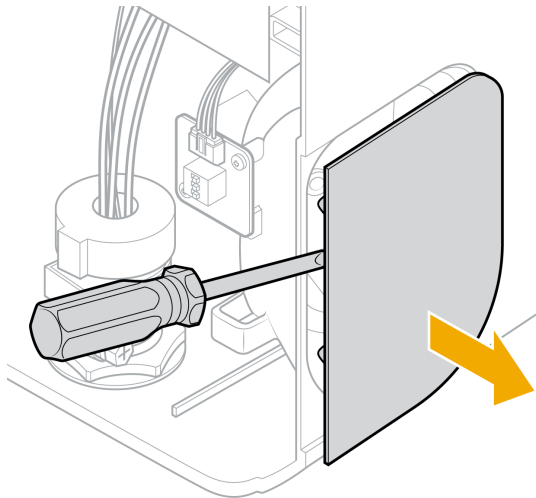

Install the Holster Assembly

1. Insert the holster assembly into the opening on the side of the Fleet AC Dispenser, aligning the two screw holes in the holster assembly with the screw holes in the interior of the Fleet AC Dispenser.
2. Use a Torx T20 Security driver to install the two Torx T20 head screws.
3. Torque each screw to 1.47 N·m.

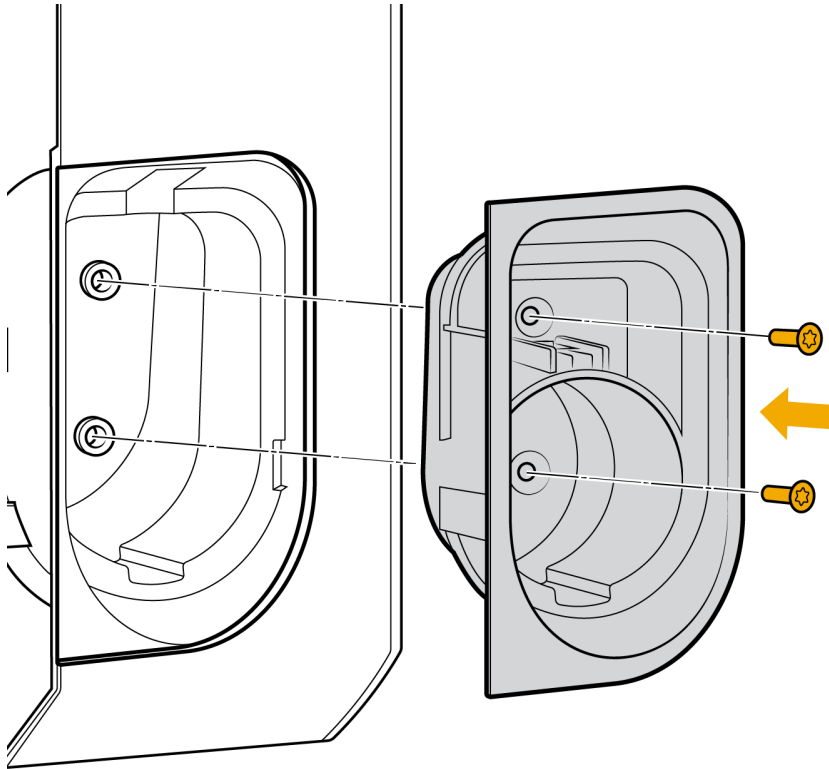

Attach the Mounting Plate

NOTE

- Feed conduit only from the bottom when mounting the Fleet AC Dispenser at an outdoor site.
- When installing on a concrete wall, select a fastener suitable for installation on concrete or stucco. Do not use the T20 fasteners provided with the product.

To a Concrete Wall

1. With the flat side of the mounting plate against the wall, and the large hole positioned in the lower-left, install a fastener in each of the four locations shown.
2. Use a level to confirm the plate is level.
3. Tighten the screws to secure the mounting plate to the wall. Ensure that both the screw and the wall are not damaged during installation.

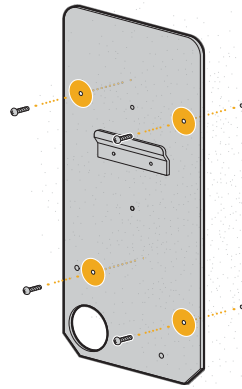

To a Finished Wall Supported by Wooden Studs

1. Use a stud finder to locate the stud(s).
2. With the flat side of the mounting plate against the stud, and the large hole positioned in the lower-left, install the T20 screws in the locations shown.
 - For a vertical stud, install a screw in each of the three center holes.
 - For a horizontal stud:
 - a. Select a location where the horizontal and vertical studs meet.
 - b. Place the three holes in the upper third of the mounting plate against the horizontal stud and the three holes down the center of the mounting plate against the vertical stud.
 - c. Install a screw in each of the two outer holes in the upper third of the mounting plate.
 - d. Install a third screw in the lower center location of the mounting plate.

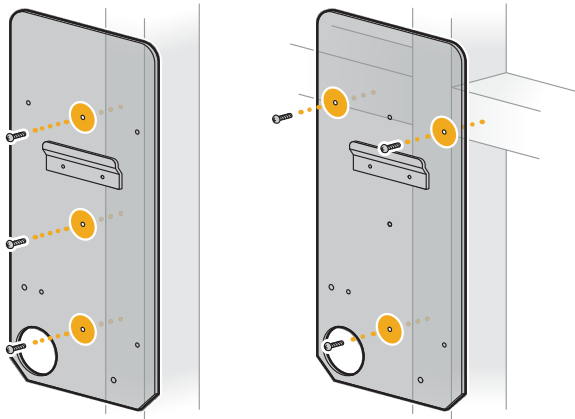

Vertical Stud Installation

Horizontal Stud Installation

3. Tighten the screws in order to attach the mounting plate to the wall. Ensure that both the screw and the wall are not damaged during installation.

Attach the Fleet AC Dispenser to the Mounting Plate

1. Determine which wire entry point to use in the Fleet AC Dispenser—rear or bottom—and remove the cover.
 - For indoor installations where wire will run inside the wall, turn the rear wire entry cover counterclockwise to release it from the Fleet AC Dispenser.

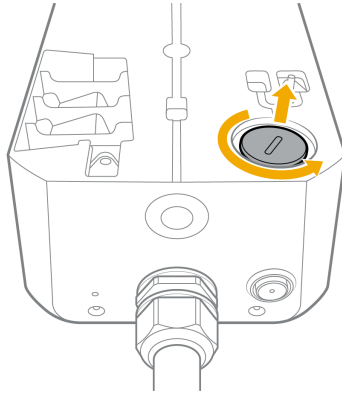

- For outdoor installations or indoor installations on concrete, knock out the 1 in (2.5 cm) or 1/2 in (1.3 cm) wire entry cover on the bottom of the Fleet AC Dispenser. Remove the knock-out debris from the interior of the Fleet AC Dispenser.

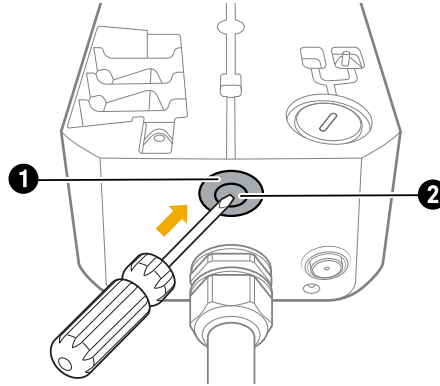

Item	Description
1	1 in (2.5 cm)
2	1/2 in (1.3 cm)

2. Hang the Fleet AC Dispenser on the installed mounting plate.

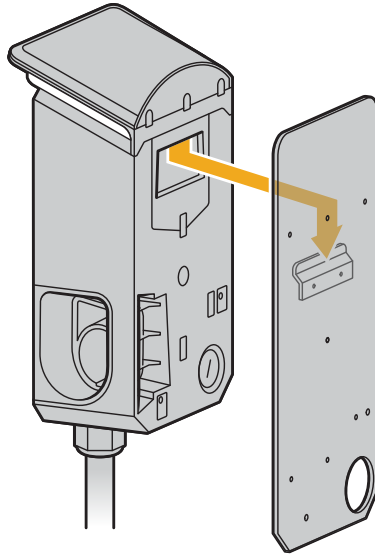



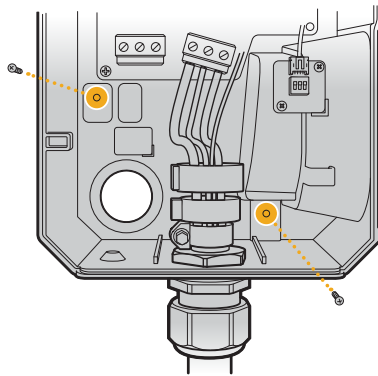





3. Use a #2 Phillips screwdriver to install the two 13 mm M4 screws through the interior of the Fleet AC Dispenser into the mounting plate.



4. Torque each screw to 12 in-lb (1.36 N·m).

Set the Operating Current

Configure the dip switches to set the operating current.

Current	Circuit Breaker Specification	Typical Conductor Specification*	Dip Switch			Figure
			1	2	3	
6 A	7.5 A	12-14 AWG	OFF	OFF	OFF	
12 A	15 A	12-14 AWG	OFF	OFF	ON	
16 A	20 A	12-10 AWG	OFF	ON	OFF	
20 A	25 A	10 AWG	OFF	ON	ON	
24 A	30 A	10 AWG	ON	OFF	OFF	
32 A	40 A	8 AWG	ON	OFF	ON	
40 A	50 A	8 AWG	ON	ON	OFF	
48 A (default)	60 A	6 AWG	ON	ON	ON	

* Use only copper conductors. These typical conductor sizes are based on the 90°C column in the National Electrical Code.

Connect Conductors

Consult a licensed electrician to select a conductor size appropriate to the breaker size and to the maximum current set.

1. Depending on the type of installation, thread conduit or conductor fittings into the rear (1) or bottom (2) entry point in the Fleet AC Dispenser. Ensure that the fittings are rated for the type and size of conductor used.

NOTE

For outdoor wall installations, insert through the bottom entry point only.

2. Trim the ends of the conductors to an appropriate length to allow for future servicing.
3. Strip the ends of the conductors 7/16 in.
4. Fully insert the conductors into the corresponding terminals (L1, Ground, L2).



DANGER

Do not overtighten the terminals

5. Torque each terminal to 10.6 in-lb (1.2 N·m).
6. After energizing the charger, use a multimeter to test the voltages on the input terminal.

Install the Faceplate



CAUTION

- Use anti-static gloves, wrist bands connected to ground, and insulated tools for installation and removal of the faceplate.
- Avoid direct hand contact with components on the network board.
- Do not connect the cable if the charger is energized. Damage to the charger can occur.

1. Position the faceplate near the front of the Fleet AC Dispenser.
2. Reconnect the cable from the Fleet AC Dispenser to the network board on the interior of the faceplate.

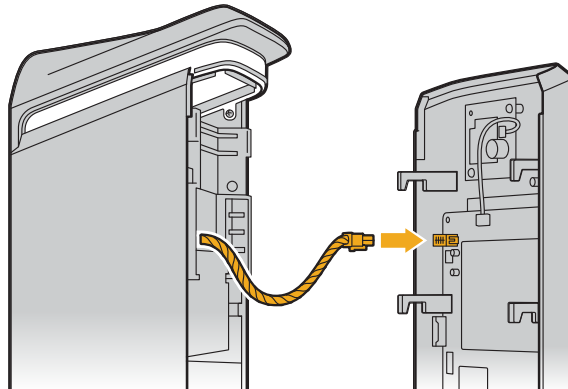

3. Slide the faceplate down onto the Fleet AC Dispenser.
4. Install the two Security T20 Torx screws.
5. Torque each Security T20 Torx screw to 12 in-lb (1.36 N·m).

Wall Installation Only - Wrap and Dock the Cable

For a wall installation, wrap the cable loosely around the Fleet AC Dispenser and store the coupler in the dock on the side.

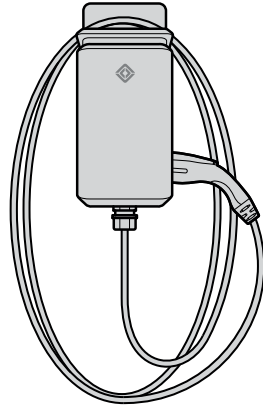

Complete the Installation

1. Check for any damage to equipment during installation and report damage to Rivian.
2. Collect and recycle any packing material.
3. Collect and dispose of all trash around the installation site.
4. Contact Rivian Network Operations to complete the installation and connect the Fleet AC Dispenser to the network.

Light Bar States

Light Bar	State	Indication
White	Solid	End of charge session after unplugging from vehicle
White	Pulsing	Initializing
White (center light only)	Pulsing	Ready
Green	Pulsing	Charging
Green	Solid	Charging complete
Blue	Solid	Waiting to charge
Blue	Fast pulsing	Bluetooth communicating
Blue	Slow pulsing	Over-the-air (OTA) software update in progress
Red	Pulsing	Error (see Troubleshooting (page 28))
Red	Solid	Error (contact Rivian (page 37))

Troubleshooting

If the Fleet AC Dispenser light is pulsing red:

1. Unplug the charger from the vehicle.
2. Switch power off and then on again at the circuit breaker.
3. Allow the Fleet AC Dispenser to boot up.

If the Fleet AC Dispenser light is solid red:

1. Switch power off and then on again at the circuit breaker.
2. If this does not solve the issue, switch the power off again at the circuit breaker.
3. Remove the faceplate from the Fleet AC Dispenser (page 25).
4. Confirm the dip switch configuration matches the installed circuit breaker.
5. Install the faceplate, making sure to **reconnect the cable to the network board** (page 25).
6. Switch power on at the circuit breaker.

If the problem persists, contact Rivian (page 37).

Specifications

Specification	Description
Voltage	208/240 VAC (-20% – +15%), single-phase
Frequency	60 Hz
Charging connector	SAE J1772
Charging cable length	18 ft
Wi-Fi	IEEE 802.11 b/g/n
Network band	2.4 GHz
Real-time clock	Yes (7 days)
Ethernet	10/100BASE-T
Bluetooth	Supports Bluetooth 5.0
Data protocol	OCPP 1.6; ISO 15118 capable
Metering accuracy	Embedded $\pm 1\%$
Operating temperature	-22°F to 122°F (-30°C to 50°C)
Storage temperature	-40°F to 176°F (-40°C to 80°C)
Wiring type	Hard-wired
Acceptable conductor sizes	#14 to #6 AWG copper only (#6 AWG required for full 48 A continuous current)
Operating current	6 A, 12 A, 16 A, 20 A, 24 A, 32 A, 40 A, 48 A (default, maximum)
Ground fault circuit interrupter	CCID 20 - EVSE will interrupt

Specification	Description
(GFCI)	charging if leakage exceeds 20 mA
IP performance	NEMA Type 3R
Impact resistance	IK8
Dimensions	Height: 16.3 in (41.4 cm) Width: 7.3 in (18.5 cm) Depth: 5.8 in (14.7 cm)
Certification	UL 1998/2231/2594; FCC Part 15B
UL file number	E520745
Product number	PT00401761 

Supplemental Information for Electrical Service Wiring

240V SPLIT-PHASE SYSTEM

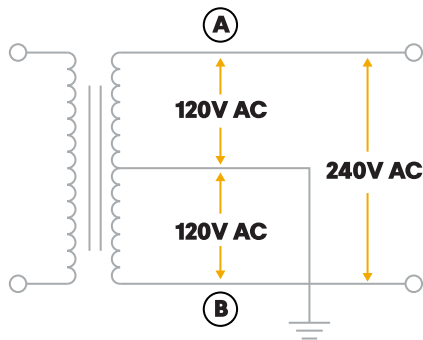

208V THREE-PHASE WYE-CONNECTED



DANGER

The center point of the three phases (used as neutral) must be single-point grounded.

In a Wye-connected secondary installation, use two of the legs to provide 208V to the charger. For example, L1 and L2, or L1 and L3, or L2 and L3. The two phases utilized must each measure 120V ground.

NOTE

A current-carrying neutral is not required for charger installation.

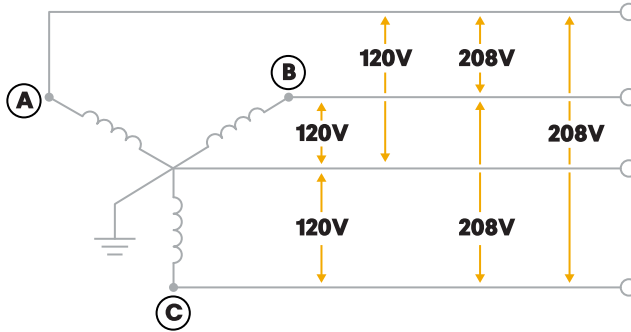

240V THREE-PHASE DELTA-CONNECTED



DANGER

- The third leg (A in the illustration) of the delta transformer is 208V to neutral and is sometimes referred to as a “high leg”. Do not use this third leg.
- Do not use a three-phase delta-connected secondary without a center tap on one leg. No neutral point is available for the required earth-ground connection.

In a delta-connected installation, one leg must be center-tapped, and only the two phases on either side of that center tap can be safely utilized. The two used phases must each measure 120V to ground.

NOTE

The charger’s contactor closes only if it detects the presence of an earth ground wire connected to a neutral point on the transformer secondary.

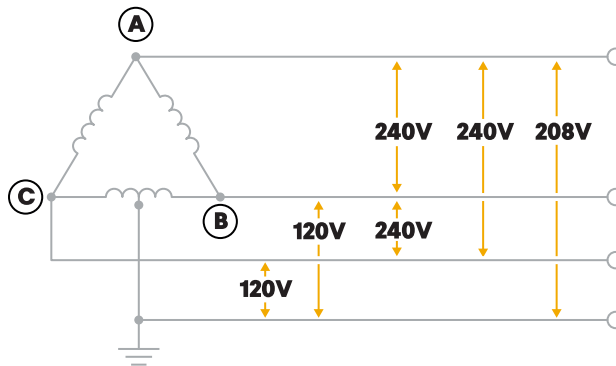



FC Federal Communication Commission Interference Statement

This equipment complies with part 15 of the FCC rules. Operation is subject to the following two conditions: (1) This equipment may not cause harmful interference, and (2) this equipment must accept any interference received, including interference that may cause undesired operation.

This equipment has been tested and found to comply with the limits for a Class B digital device, pursuant to Part 15 of the FCC rules. These limits are designed to provide reasonable protection against harmful interference in a residential installation. This equipment generates, uses, and can radiate radio frequency energy and, if not installed and used in accordance with the instructions, may cause harmful interference to radio communications. However, there is no guarantee that interference will not occur in a particular installation. If this equipment does cause harmful interference to radio or television reception, which can be determined by turning the equipment off and on, the user is encouraged to try to correct the interference by one or more of the following measures:

- Reorient or relocate the receiving antenna.
- Increase the separation between the equipment and receiver.
- Connect the equipment into an outlet on a circuit different from that to which the receiver is connected.
- Consult the dealer or an experienced radio/TV technician for help.

Changes or modifications not covered in this Guide must be approved in writing by the manufacturer's Regulatory Engineering Department. Changes or modifications made without written approval may void the user's authority to operate this equipment.

RF EXPOSURE INFORMATION

This device has been tested and meets applicable limits for Radio Frequency (RF) exposure.

Keep a minimum distance of 8 in (20 cm) between you and the Fleet AC Dispenser while installing or operating it.

Industry Canada Statement

This equipment complies with ISED's license-exempt RSSs. Operation is subject to the following two conditions: (1) This device may not cause harmful interference, and (2) this equipment must accept any interference received, including interference that may cause undesired operation.

Le présent appareil est conforme aux CNR d'ISED applicables aux appareils radio exempts de licence. L'exploitation est autorisée aux deux conditions suivantes: (1) le dispositif ne doit pas produire de brouillage préjudiciable, et (2) ce dispositif doit accepter tout brouillage reçu, y compris un brouillage susceptible de provoquer un fonctionnement indésirable.

RADIATION EXPOSURE STATEMENT

This equipment complies with ISED radiation exposure limits set forth for an uncontrolled environment. This equipment should be installed and operated with greater than 20 cm between the radiator and your body.

DÉCLARATION D'EXPOSITION AUX RADIATIONS

Cet équipement est conforme aux limites d'exposition aux rayonnements ISED établies pour un environnement non contrôlé. Cet équipement doit être installé et utilisé à plus de 20 cm entre le radiateur et votre corps.



Page left intentionally blank.





Still need help? Connect with us.

Customer Service

Call (888) RIVIAN1 / (888) 748-4261
customerservice@rivian.com
rivian.com Support Center and Chat



Page left intentionally blank.

