

TEST REPORT

Applicant: CITAQ CO., LTD

Address of Applicant: 9F&13/F, Chuangye Bldg, Keji Middle Road Hi-Tech Zone, Shantou, Guangdong, China

Manufacturer: CITAQ CO., LTD

Address of Manufacturer: 9F&13/F, Chuangye Bldg, Keji Middle Road Hi-Tech Zone, Shantou, Guangdong, China

Equipment Under Test (EUT)

Product Name: POS SYSTEM

Model No.: H10-4, H10, H10-1, H10-3, H10-31, H10-32, H10-33, H10-34, H10-35, H10-41, H10-42, H10-43, H10-44, H10-45, V8, V8-1, V8-2, V8-3, V8-4, V8-5

Trade Mark: CITAQ

FCC ID: 2AVZV-H10-4

Applicable standards: FCC CFR Title 47 Part 2
FCC CFR Title 47 Part 22
FCC CFR Title 47 Part 27

Date of sample receipt: September 15, 2021

Date of Test: September 16-23, 2021

Date of report issued: September 23, 2021

Test Result : PASS *

* In the configuration tested, the EUT complied with the standards specified above.

Authorized Signature:



Robinson Luo
Laboratory Manager

This results shown in this test report refer only to the sample(s) tested, this test report cannot be reproduced, except in full, without prior written permission of the company. The report would be invalid without specific stamp of test institute and the signatures of compiler and approver.

2 Version

Version No.	Date	Description
00	September 23, 2021	Original

Prepared By:

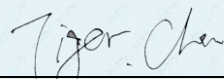
Project Engineer

Date:

September 23, 2021

Check By:

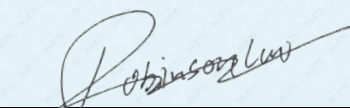
Reviewer

Date:

September 23, 2021

3 Contents

	Page
1 COVER PAGE.....	1
2 VERSION.....	2
3 CONTENTS	3
4 TEST SUMMARY	4
5 GENERAL INFORMATION.....	5
5.1 GENERAL DESCRIPTION OF EUT	5
5.2 RELATED SUBMITTAL(S) / GRANT (S).....	7
5.3 TEST METHODOLOGY	7
5.4 TEST FACILITY.....	7
5.5 TEST LOCATION	7
6 TEST INSTRUMENTS LIST	8
7 SYSTEM TEST CONFIGURATION	10
7.1 TEST MODE	10
7.2 CONFIGURATION OF TESTED SYSTEM	10
7.3 CONDUCTED OUTPUT POWER & E.R.P. & E.I.R.P.....	11
7.4 PEAK-TO-AVERAGE RATIO.....	12
7.5 OCCUPY BANDWIDTH.....	13
7.6 MODULATION CHARACTERISTIC	14
7.7 OUT OF BAND EMISSION AT ANTENNA TERMINALS	14
7.8 FIELD STRENGTH OF SPURIOUS RADIATION MEASUREMENT	15
7.9 FREQUENCY STABILITY V.S. TEMPERATURE MEASUREMENT	19
7.10 FREQUENCY STABILITY V.S. VOLTAGE MEASUREMENT	20
8 TEST SETUP PHOTO	20
9 EUT CONSTRUCTIONAL DETAILS	20

4 Test Summary

Test Item	Section in CFR 47	Result
RF Output Power	Part 2.1046 Part 22.913 (a) Part 27.50(h)	Pass
Peak-to-Average Ratio	Part 22.913(d) FCC Part 27.50(h)	Pass
Modulation Characteristics	Part 2.1047	N/A
99% & -26 dB Occupied Bandwidth	Part 2.1049 Part 22.917(b) Part 27.53(h)	Pass
Spurious Emissions at Antenna Terminal	Part 2.1051 Part 22.917 Part 27.53(m)	Pass
Field Strength of Spurious Radiation	Part 2.1053 Part 22.917 Part 27.53(m))	Pass
Out of band emission, Band Edge	Part 22.917 Part 27.53(m)	Pass
Frequency stability vs. temperature	Part 2.1055(a)(1)(b)	Pass
Frequency stability vs. voltage	Part 2.1055(d)(1)(2)	Pass

Remarks:

1. *Pass: The EUT complies with the essential requirements in the standard.*
2. *N/A: Not applicable.*

5 General Information

5.1 General Description of EUT

Product Name:	POS SYSTEM
Model No.:	H10-4, H10, H10-1, H10-3, H10-31, H10-32, H10-33, H10-34, H10-35, H10-41, H10-42, H10-43, H10-44, H10-45, V8, V8-1, V8-2, V8-3, V8-4, V8-5
Test Model No.:	H10-4
Remark: All above models are identical in the same PCB layout, interior structure and electrical circuits. The only difference is model name for commercial purpose.	
Serial No.:	N/A
Tested Sample(s) ID:	GTSL202109000132-1
Sample(s) Status:	Engineer sample
Support Networks:	LTE
Support Bands:	LTE Band 5/7/41
Channel Bandwidth:	LTE Band 5: 1.4MHz; 3MHz; 5MHz; 10MHz LTE Band 7: 5MHz; 10MHz; 15MHz; 20MHz LTE Band 41: 5MHz; 10MHz; 15MHz; 20MHz
TX Frequency:	LTE Band 5: 824MHz-849MHz LTE Band 7: 2500MHz-2570MHz LTE Band 41: 2496MHz ~2690MHz
Modulation type:	QPSK, 16QAM
Antenna type:	Internal Antenna
Antenna gain:	2dBi(declare by applicant)
Power supply:	Adapter Model: K65S240250E1 Input: AC 100-240V, 50/60Hz, 1.8A Output: DC 24.0V, 2.5A, 60.0W

Test Frequency

Test Mode	Channel Bandwidth	RF Channel		
		Lowest channel	Middle channel	Highest channel
LTE Band 5	1.4M	824.7 MHz	836.5 MHz	848.3 MHz
	3M	825.5 MHz	836.5 MHz	847.5 MHz
	5M	826.5 MHz	836.5 MHz	846.5 MHz
	10M	829.0 MHz	836.5 MHz	844.0 MHz

Test Mode	Channel Bandwidth	RF Channel		
		Lowest channel	Middle channel	Highest channel
LTE Band 7	5M	2502.5 MHz	2535 MHz	2567.5 MHz
	10M	2505 MHz	2535 MHz	2565 MHz
	15M	2507.5 MHz	2535 MHz	2562.5 MHz
	20M	2510 MHz	2535 MHz	2560 MHz

Test Mode	Channel Bandwidth	RF Channel		
		Lowest channel	Middle channel	Highest channel
LTE Band 41	5M	2498.5MHz	2593.0 MHz	2687.5 MHz
	10M	2501.0 MHz	2593.0 MHz	2685.0 MHz
	15M	2503.5 MHz	2593.0 MHz	2682.5 MHz
	20M	2506.0 MHz	2593.0 MHz	2680.0 MHz

5.2 Related Submittal(s) / Grant (s)

This submittal(s) (test report) is filing to comply with Section Part 22/27 of the FCC CFR 47 Rules.

5.3 Test Methodology

Both conducted and radiated testing were performed according to the procedures document on ANSI C63.26:2015 and FCC CFR 47.1046, 2.1047, 2.1049, 2.1051, 2.1053, 2.1055 and 2.1057

5.4 Test Facility

The test facility is recognized, certified, or accredited by the following organizations:

- **FCC —Registration No.: 381383**

Global United Technology Services Co., Ltd., Shenzhen EMC Laboratory has been registered and fully described in a report filed with the (FCC) Federal Communications Commission. The acceptance letter from the FCC is maintained in files. Registration 381383.

- **IC —Registration No.: 9079A**

The 3m Semi-anechoic chamber of Global United Technology Services Co., Ltd. has been registered by Certification and Engineering Bureau of Industry Canada for radio equipment testing with Registration No.: 9079A.

- **NVLAP (LAB CODE:600179-0)**

Global United Technology Services Co., Ltd., is accredited by the National Voluntary Laboratory Accreditation Program (NVLAP). LAB CODE:600179-0

5.5 Test Location

All tests were performed at:

Global United Technology Services Co., Ltd.

Address: No. 123-128, Tower A, Jinyuan Business Building, No.2, Laodong Industrial Zone, Xixiang Road, Baoan District, Shenzhen, Guangdong, China 518102

Tel: 0755-27798480

Fax: 0755-27798960

6 Test Instruments list

Radiated Emission:						
Item	Test Equipment	Manufacturer	Model No.	Inventory No.	Cal.Date (mm-dd-yy)	Cal.Due date (mm-dd-yy)
1	3m Semi- Anechoic Chamber	ZhongYu Electron	9.2(L)*6.2(W)* 6.4(H)	GTS250	July. 02 2020	July. 01 2025
2	Control Room	ZhongYu Electron	6.2(L)*2.5(W)* 2.4(H)	GTS251	N/A	N/A
3	EMI Test Receiver	Rohde & Schwarz	ESU26	GTS203	June. 24 2021	June. 23 2022
4	BiConiLog Antenna	SCHWARZBECK MESS-ELEKTRONIK	VULB9163	GTS214	June. 24 2021	June. 23 2022
5	Double -ridged waveguide horn	SCHWARZBECK MESS-ELEKTRONIK	BBHA 9120 D	GTS208	June. 24 2021	June. 23 2022
6	Horn Antenna	ETS-LINDGREN	3160	GTS217	June. 24 2021	June. 23 2022
7	EMI Test Software	AUDIX	E3	N/A	N/A	N/A
8	Coaxial Cable	GTS	N/A	GTS213	June. 24 2021	June. 23 2022
9	Coaxial Cable	GTS	N/A	GTS211	June. 24 2021	June. 23 2022
10	Coaxial cable	GTS	N/A	GTS210	June. 24 2021	June. 23 2022
11	Coaxial Cable	GTS	N/A	GTS212	June. 24 2021	June. 23 2022
12	Amplifier(100kHz-3GHz)	HP	8347A	GTS204	June. 24 2021	June. 23 2022
13	Amplifier(2GHz-20GHz)	HP	84722A	GTS206	June. 24 2021	June. 23 2022
14	Amplifier (18-26GHz)	Rohde & Schwarz	AFS33-18002 650-30-8P-44	GTS218	June. 24 2021	June. 23 2022
15	Band filter	Amindeon	82346	GTS219	June. 24 2021	June. 23 2022
16	Power Meter	Anritsu	ML2495A	GTS540	June. 24 2021	June. 23 2022
17	Power Sensor	Anritsu	MA2411B	GTS541	June. 24 2021	June. 23 2022
18	Wideband Radio Communication Tester	Rohde & Schwarz	CMW500	GTS575	June. 24 2021	June. 23 2022
19	Splitter	Agilent	11636B	GTS237	June. 24 2021	June. 23 2022
20	Loop Antenna	ZHINAN	ZN30900A	GTS534	June. 24 2021	June. 23 2022
21	Breitband hornantenne	SCHWARZBECK	BBHA 9170	GTS579	Oct. 18 2020	Oct. 17 2021
22	Amplifier	TDK	PA-02-02	GTS574	Oct. 18 2020	Oct. 17 2021
23	Amplifier	TDK	PA-02-03	GTS576	Oct. 18 2020	Oct. 17 2021
24	PSA Series Spectrum Analyzer	Rohde & Schwarz	FSP	GTS578	June. 24 2021	June. 23 2022

RF Conducted Test:						
Item	Test Equipment	Manufacturer	Model No.	Serial No.	Cal.Date (mm-dd-yy)	Cal.Due date (mm-dd-yy)
1	MXA Signal Analyzer	Agilent	N9020A	GTS566	June. 24 2021	June. 23 2022
2	EMI Test Receiver	R&S	ESCI 7	GTS552	June. 24 2021	June. 23 2022
3	Spectrum Analyzer	Agilent	E4440A	GTS533	June. 24 2021	June. 23 2022
4	MXG vector Signal Generator	Agilent	N5182A	GTS567	June. 24 2021	June. 23 2022
5	ESG Analog Signal Generator	Agilent	E4428C	GTS568	June. 24 2021	June. 23 2022
6	USB RF Power Sensor	DARE	RPR3006W	GTS569	June. 24 2021	June. 23 2022
7	RF Switch Box	Shongyi	RFSW3003328	GTS571	June. 24 2021	June. 23 2022
8	Programmable Constant Temp & Humi Test Chamber	WEWON	WHTH-150L-40-880	GTS572	June. 24 2021	June. 23 2022

General used equipment:						
Item	Test Equipment	Manufacturer	Model No.	Inventory No.	Cal.Date (mm-dd-yy)	Cal.Due date (mm-dd-yy)
1	Humidity/ Temperature Indicator	KTJ	TA328	GTS243	June. 24 2021	June. 23 2022
2	Barometer	ChangChun	DYM3	GTS255	June. 24 2021	June. 23 2022

7 System test configuration

7.1 Test mode

During all testing, EUT is in link mode with base station emulator at maximum power level. The spurious emission measurements were carried out in semi-anechoic chamber with 3-meter test range, and EUT is rotated on three test planes to find out the worst emission.

Test modes		
Band	Radiated	Conducted
LTE Band 5	■ QPSK and 16QAM link	■ QPSK and 16QAM link
LTE Band 7	■ QPSK and 16QAM link	■ QPSK and 16QAM link
LTE Band 41	■ QPSK and 16QAM link	■ QPSK and 16QAM link

7.2 Configuration of Tested System

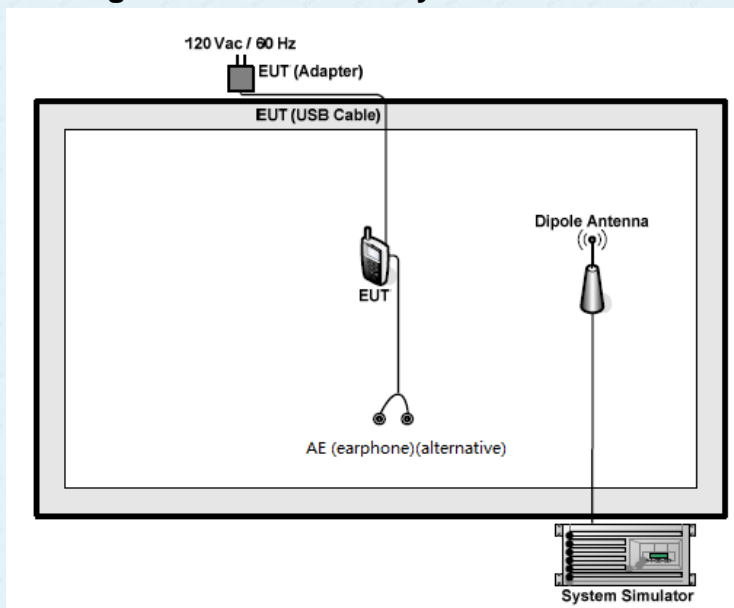

7.3 Conducted Output Power & E.R.P. & E.I.R.P.

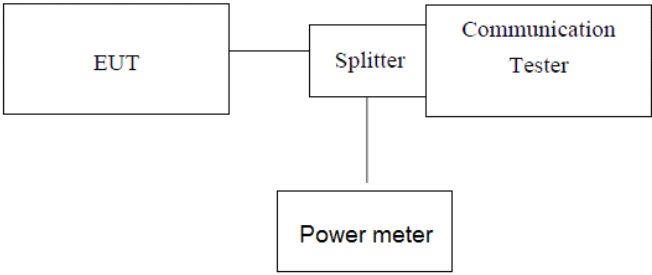
Test Requirement:	FCC part 22.913; Part 27.50
Test Method:	FCC part2.1046
Limit:	LTE Band 5: 7W LTE Band 7: 2W LTE Band 41: 2W
Test setup:	 <p style="text-align: center;"><i>Note: Measurement setup for testing on Antenna connector</i></p>
Test Instruments:	Refer to section 6.0 for details
Test mode:	Refer to section 7.1 for details
Test results:	Pass

Measurement Data: The detailed test data see Appendix

7.4 Peak-to-Average Ratio

Test Requirement:	FCC part 22.913(d) & FCC Part 27.50
Test Method:	FCC part2.1046
Limit:	13db
Test setup:	<pre> graph LR CC[Control Computer] --> EUT[EUT] PS[Power Supply] --> EUT subgraph EUT CP[Control port(s)] AP[Antenna port(s)] PP[Power port] end EUT <--> PD[Power Divider] PD --> WC[Wireless Communication] PD --> SA[Spectrum Analyzer] </pre>
Test Instruments:	Refer to section 6.0 for details
Test mode:	Refer to section 7.1 for details
Test results:	Pass

Measurement data: The detailed test data see Appendix

7.5 Occupy Bandwidth

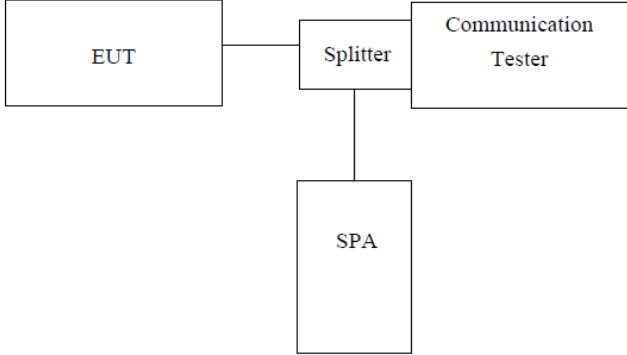
Test Requirement:	Part 27.53; part 22.917
Test Method:	FCC part2.1049
Test setup:	 <p><i>Note: Measurement setup for testing on Antenna connector</i></p>
Test Procedure:	<ol style="list-style-type: none"> 1. The EUT's output RF connector was connected with a short cable to the spectrum analyzer 2. RBW was set to about 1% of emission BW, VBW= 3 times RBW. 3. -26dBc display line was placed on the screen (or 99% bandwidth), the occupied bandwidth is the delta frequency between the two points where the display line intersects the signal trace.
Test Instruments:	Refer to section 6.0 for details
Test mode:	Refer to section 7.1 for details
Test results:	Pass

Measurement Data: The detailed test data see Appendix

7.6 MODULATION CHARACTERISTIC

According to FCC § 2.1047(d), Part 27 there is no specific requirement for digital modulation, therefore modulation characteristic is not presented.

7.7 Out of band emission at antenna terminals

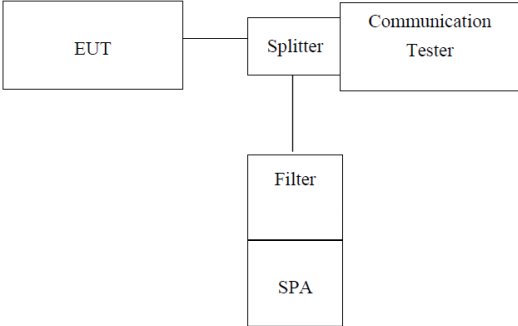
Test Requirement:	Part 27.53; Part 22.917
Test Method:	FCC part2.1051
Test setup:	 <p><i>Note: Measurement setup for testing on Antenna connector</i></p>
Test Procedure:	<ol style="list-style-type: none"> 1 The RF output of the transceiver was connected to a spectrum analyzer through appropriate attenuation. 2 The resolution bandwidth of the spectrum analyzer was set at 1MHz, sufficient scans were taken to show the out of band Emissions if any up to 10th harmonic. 3 For the out of band: Set the RBW, VBW = 1MHz, Start=30MHz, Stop= 10th harmonic. 4 Band Edge Requirements: In the 1 MHz bands immediately outside and adjacent to the frequency block, a resolution bandwidth of at least 1 percent of the emission bandwidth of the fundamental emission of the transmitter may be employed to measure the out of band Emissions.
Test Instruments:	Refer to section 6.0 for details
Test mode:	Refer to section 7.1 for details
Test results:	Pass

Measurement Data: The detailed test data see Appendix

7.8 Field strength of spurious radiation measurement

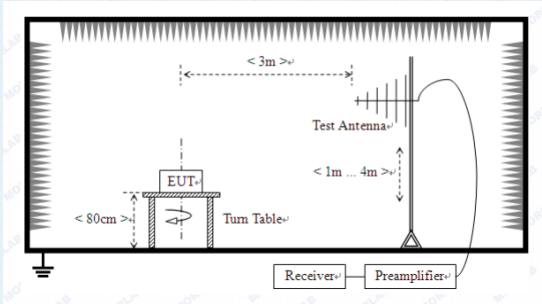
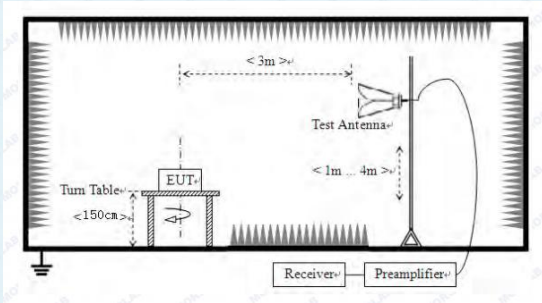
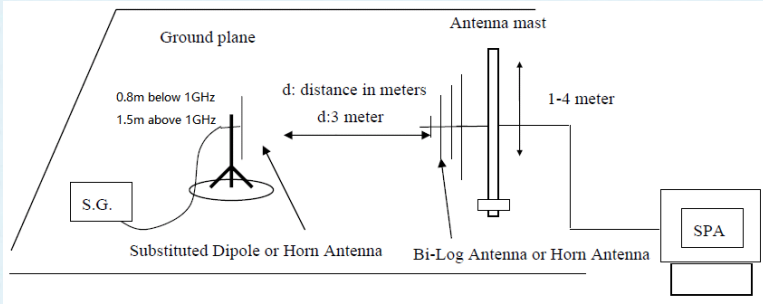
Test Requirement:	Part 22.917; FCC Part 27.53(m)
Test Method:	FCC part 2.1053 and ANSI C63.26:2015
Test setup:	<p>Below 1GHz</p>  <p>Above 1GHz</p>  <p>Substituted method:</p> 
Test Instruments:	Refer to section 6.0 for details
Test mode:	Refer to section 7.1 for details
Test results:	Pass

Measurement Data:

All conditions were test, only report worst case.

LTE Band 5 @10MHz, QPSK								
Channel	Frequency(MHz)	Polarization	SGP [dBm]	Substitution Gain[dBi]	Cable loss[dB]	ERP (dBm)	Limit (dBm)	Over Limit (dBm)
Lowest	1658	H	-51.57	6.74	2.38	-49.36	-13	-36.36
	2487	H	-51.09	8.94	2.99	-47.29	-13	-34.29
	3316	H	-52.71	10.62	3.63	-47.87	-13	-34.87
	1658	V	-49.54	6.74	2.38	-47.33	-13	-34.33
	2487	V	-47.84	8.94	2.99	-44.04	-13	-31.04
	3316	V	-52.14	10.62	3.63	-47.3	-13	-34.3
Middle	1673	H	-47.09	6.74	2.39	-44.89	-13	-31.89
	2509.5	H	-49.42	8.94	3.03	-45.66	-13	-32.66
	3346	H	-51	10.62	3.63	-46.16	-13	-33.16
	1673	V	-52.78	6.74	2.39	-50.58	-13	-37.58
	2509.5	V	-47.42	8.94	3.03	-43.66	-13	-30.66
	3346	V	-52.74	10.62	3.63	-47.9	-13	-34.9
Highest	1688	H	-52.58	6.74	2.39	-50.38	-13	-37.38
	2532	H	-50.89	8.94	3.04	-47.14	-13	-34.14
	3376	H	-51.39	10.62	3.64	-46.56	-13	-33.56
	1688	V	-47.98	6.74	2.39	-45.78	-13	-32.78
	2532	V	-51.54	8.94	3.04	-47.79	-13	-34.79
	3376	V	-48.81	10.62	3.64	-43.98	-13	-30.98

Remark: Spurious emissions within 30-1000MHz were found more than 20dB below limit

LTE Band 7 @20MHz, QPSK								
Channel	Frequency(MHz)	Polarization	SGP [dBm]	Substitution Gain[dBi]	Cable loss[dB]	EIRP (dBm)	Limit (dBm)	Over Limit (dBm)
Lowest	5020	H	-50.04	4.36	4.84	-50.52	-13	-37.52
	7530	H	-49.89	4.77	6.82	-51.94	-13	-38.94
	10040	H	-49.5	5.12	8.14	-52.52	-13	-39.52
	5020	V	-49.48	4.36	4.84	-49.96	-13	-36.96
	7530	V	-50.84	4.77	6.82	-52.89	-13	-39.89
	10040	V	-49.53	5.12	8.14	-52.55	-13	-39.55
Middle	5070	H	-48.1	4.36	4.88	-48.62	-13	-35.62
	7605	H	-50.13	4.77	6.81	-52.17	-13	-39.17
	10140	H	-51.92	5.12	8.18	-54.98	-13	-41.98
	5070	V	-49.67	4.36	4.88	-50.19	-13	-37.19
	7605	V	-51.18	4.77	6.81	-53.22	-13	-40.22
	10140	V	-49.42	5.12	8.18	-52.48	-13	-39.48
Highest	5120	H	-48.73	4.36	4.92	-49.29	-13	-36.29
	7680	H	-48.3	4.77	6.79	-50.32	-13	-37.32
	10240	H	-50.07	5.12	8.22	-53.17	-13	-40.17
	5120	V	-50.05	4.36	4.92	-50.61	-13	-37.61
	7680	V	-52.73	4.77	6.79	-54.75	-13	-41.75
	10240	V	-51.8	5.12	8.22	-54.9	-13	-41.9

Remark: Spurious emissions within 30-1000MHz were found more than 20dB below limit

LTE Band 41 @20MHz, QPSK								
Channel	Frequency(MHz)	Polarization	SGP [dBm]	Substitution Gain[dBi]	Cable loss[dB]	EIRP (dBm)	Limit (dBm)	Over Limit (dBm)
Lowest	5012.00	H	-49.41	4.31	4.94	-50.04	-25	-25.04
	7518.00	H	-48.12	5.74	6.79	-49.17	-25	-24.17
	10024.00	H	-52.71	5.26	8.23	-55.68	-25	-30.68
	5012.00	V	-51.28	4.31	4.94	-51.91	-25	-26.91
	7518.00	V	-50.78	5.74	6.79	-51.83	-25	-26.83
	10024.00	V	-48.73	5.26	8.23	-51.7	-25	-26.7
Middle	5186.00	H	-49.3	4.31	5	-49.99	-25	-24.99
	7779.00	H	-47.09	5.74	6.77	-48.12	-25	-23.12
	10372.00	H	-51.55	5.26	8.29	-54.58	-25	-29.58
	5186.00	V	-49.21	4.31	5	-49.9	-25	-24.9
	7779.00	V	-49.92	5.74	6.77	-50.95	-25	-25.95
	10372.00	V	-53	5.26	8.29	-56.03	-25	-31.03
Highest	5360.00	H	-51.27	4.31	5.06	-52.02	-25	-27.02
	8040.00	H	-51.11	5.74	6.74	-52.11	-25	-27.11
	10720.00	H	-49.92	5.26	8.36	-53.02	-25	-28.02
	5360.00	V	-50.89	4.31	5.06	-51.64	-25	-26.64
	8040.00	V	-47.63	5.74	6.74	-48.63	-25	-23.63
	10720.00	V	-51.86	5.26	8.36	-54.96	-25	-29.96

Remark: Spurious emissions within 30-1000MHz were found more than 20dB below limit

7.9 Frequency stability V.S. Temperature measurement

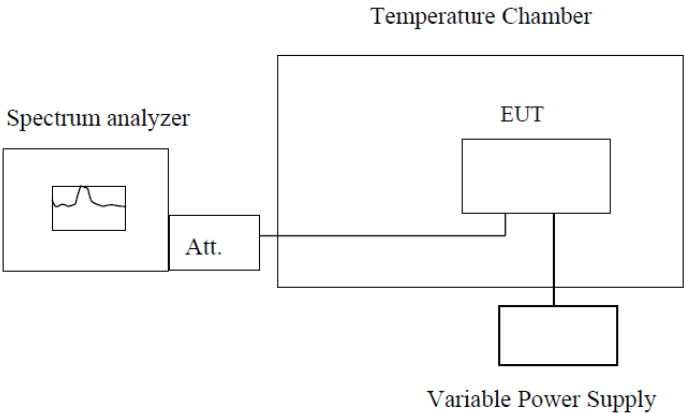
Test Requirement:	FCC Part2.1055(a)(1)(b)
Test Method:	FCC Part2.1055(a)(1)(b)
Limit:	2.5ppm
Test setup:	 <p>Note : Measurement setup for testing on Antenna connector</p>
Test procedure:	<ol style="list-style-type: none"> 1. The equipment under test was connected to an external DC power supply and input rated voltage. 2. RF output was connected to a frequency counter or spectrum analyzer via feed through attenuators. 3. The EUT was placed inside the temperature chamber. 4. Set the spectrum analyzer RBW low enough to obtain the desired frequency resolution and measure EUT 25°C operating frequency as reference frequency. 5. Turn EUT off and set the chamber temperature to -20°C. After the temperature stabilized for approximately 30 minutes recorded the frequency. 6. Repeat step measure with 10°C increased per stage until the highest temperature of +50°C reached.
Test Instruments:	Refer to section 6.0 for details
Test mode:	Refer to section 7.1 for details
Test results:	Pass

Measurement Data: The detailed test data see Appendix

7.10 Frequency stability V.S. Voltage measurement

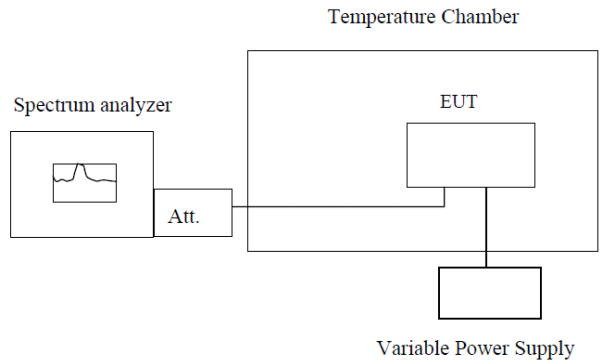
Test Requirement:	FCC Part2.1055(d)(1)(2)
Test Method:	FCC Part2.1055(d)(1)(2)
Limit:	2.5ppm
Test setup:	 <p>Note : Measurement setup for testing on Antenna connector</p>
Test procedure:	<ol style="list-style-type: none"> 1. Set chamber temperature to 25°C. Use a variable DC power source to power the EUT and set the voltage to rated voltage. 2. Set the spectrum analyzer RBW low enough to obtain the desired frequency resolution and recorded the frequency. 3. Reduce the input voltage to specified extreme voltage variation (+/- 15%) and endpoint, record the maximum frequency change.
Test Instruments:	Refer to section 6.0 for details
Test mode:	Refer to section 7.1 for details
Test results:	Pass

Measurement Data: The detailed test data see Appendix

8 Test Setup Photo

Reference to the **appendix I** for details.

9 EUT Constructional Details

Reference to the **appendix II** for details.

-----End-----