

承認書

SPECIFICATION FOR APPROVAL

CUSTOMER: _____ 1324 _____

SAMPLE NO: _____ 230414424 _____

DDY PART NO: _____ 68IW 44×0.5H-6R7K-FP _____

CUST MODEL NO: _____

DESCRIPTION: _____ 无线充线圈 _____

DRAWING		
MADE	CHECKED	APPROVED
姚慧娟	黄积有	周光军
DATE: 2023年4月14日		

CUSTOMER APPROVE

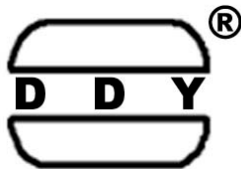

惠州市德立電子有限公司

HUI ZHOU DELI ELECTRONICS CO., LTD

廣東省博羅縣洲際工業園梅園三路

NO.3 MEI YUAN ROAD,ZHOU JI INDUSTRIAL AREA,BOLUO COUNTY GUANGDONG

電話：0752-6207968 0752-6207962

傳真：0752-6207969

郵編：516100

Http://ddycoils.com

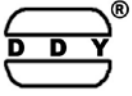

惠州市德立电子有限公司
HUI ZHOU DELI ELECTRONICS CO., LTD

CUSTOMER:	1324	REV NO:	A
DESCRIPTION:	无线充线圈	PAGE NO:	PAGE 1 OF 6
CUST P/N:		SN.	230414424
PART NO:	68IW 44×0.5H-6R7K-FP	DATE:	2023/4/14

目 录

变更履历表	P2
尺寸/特性/编码方式	P3
测试数据	P4
焊接推荐/材料清单	P5
包装信息	P6

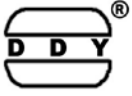

惠州市德立电子有限公司
HUI ZHOU DELI ELECTRONICS CO., LTD

CUSTOMER:	1324	REV NO:	A
DESCRIPTION:	无线充线圈	PAGE NO:	PAGE 3 OF 6
CUST P/N:		SN.	230414424
PART NO:	68IW 44×0.5H-6R7K-FP	DATE:	2023/4/14

1. SHAPES AND DIMENGSIONS (UNIT:mm)

ELECTRICAL SCHEMATICS

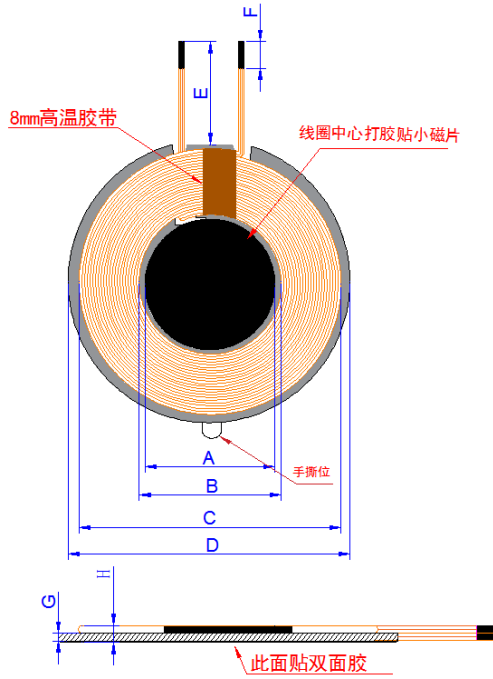

SPEC. (mm)	
A	18±0.5
B	20.5±0.5
C	40.5±1
D	44±1
E	7±1
F	3.5±1.5
G	0.5±0.2
H	不含离型纸1.6 MAX

URNS: 10Ts

注: 逆绕

2. ELECTRICAL SPECIFICATION & TEST INSTRUMENTS@25°C

ITEM	SPEC. RANGE	TEST CONDITION	TEST INSTRUMENTS
L	6.7uH±10% 加磁片	100KHz/1V	TH2828
DCR	65mΩ MAX	25°C	502BC

3. PART NUMBERING SYSTEM

68IW - □ × □ - □ - □□
1 2 3 4 5

- 1 PRODUCT SYMBOL (产品代号)
- 2 OUTER DIAMETER (外径)
- 3 ALTITUDE (高度)
- 4 INDUCTANCE (电感量)
- 5 E.P. (环保): LF—Lead Free HF—Halogen Free FP—Red Phosphor Free

APPROVED BY	CHECKED BY	DRAFT
周光军	黄积有	姚慧娟



惠州市德立电子有限公司
HUI ZHOU DELI ELECTRONICS CO., LTD

CUSTOMER:	1324	REV NO:	A
DESCRIPTION:	无线充线圈	PAGE NO:	PAGE 4 OF 6
CUST P/N:		SN.	230414424
PART NO:	68IW 44×0.5H-6R7K-FP	DATE:	2023/4/14

4. TEST DATA OF ELECTRICAL CHARACTERISTIC

ELECTRICAL CHARACTERISTIC				DIMENSIONS(mm)									
TEST ITEM	L	DCR		A	B	C	D	E	F	G	H		
	100KHz/1V	25°C		(mm)	(mm)	(mm)	(mm)	(mm)	(mm)	(mm)	(mm)		
CON.				18±0.5	20.5±0.5	40.5±1	44±1	7±1	3.5±1.5	0.5±0.2	不含离型纸1.6 MAX		
SPEC.	6.7uH±10% 加磁片	65mΩ MAX											
1	6.68	45.4		18.16	20.43	40.80	43.42	7.20	3.63	0.50	1.50		
2	6.73	45.5		18.09	20.42	40.60	43.55	7.20	3.70	0.50	1.50		
3	6.75	45.6		18.21	20.43	40.71	43.63	7.12	3.71	0.50	1.50		
4	6.76	45.5		18.08	20.43	40.75	43.45	7.18	3.67	0.50	1.50		
5	6.80	45.4		18.09	20.42	40.68	43.51	7.16	3.61	0.50	1.50		
6													
7													
8													
9													
10													
X	6.74	45.48	#DIV/0!	18.13	20.43	40.71	43.51	7.17	3.66	0.50	1.50		
R	0.12	0.20	0.00	0.13	0.01	0.20	0.21	0.08	0.10	0.00	0.00		

综合判定:
COLLIGATION DETERMINANT:
 OK NG

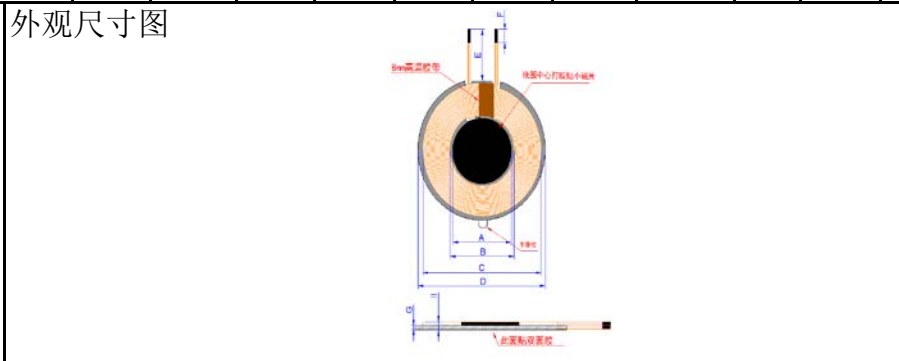

APPROVED BY	CHECKED BY	DRAFT
周光军	黄积有	姚慧娟

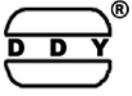

惠州市德立电子有限公司
HUI ZHOU DELI ELECTRONICS CO., LTD

CUSTOMER:	1324	REV NO:	A
DESCRIPTION:	无线充线圈	PAGE NO:	PAGE 5 OF 6
CUST P/N:		SN.	230414424
PART NO:	68IW 44×0.5H-6R7K-FP	DATE:	2023/4/14

5.Soldering Conditions

Wave Soldering:

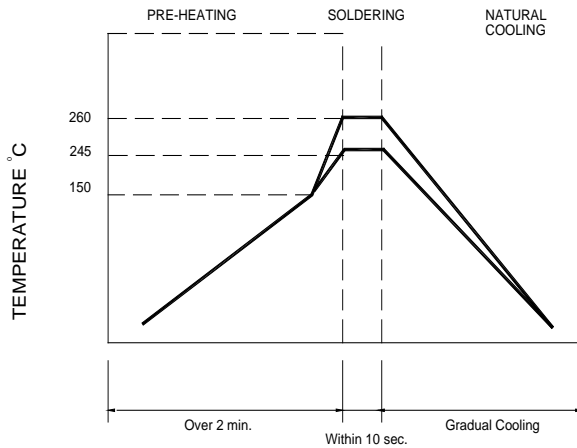

- Note :
- Never contact the ceramic with the iron tip
 - 1.0mm tip diameter (max)

6.MATERIAL LIST

NO	ITEM	DESCRIPTION	SUPPLIER	RATING	UL File
1	热风线	0.08*80P			
2	圆形双槽带孔硬磁片	G44*5.3*0.5mm			
3	胶水	树脂胶			
4	高温胶纸	8mm 宽			
5	双面胶	43*5*0.08mm			
5	小磁片	18*0.8mm			

APPROVED BY	CHECKED BY	DRAWN BY
周光军	黄积有	姚慧娟

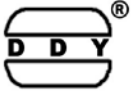

惠州市德立电子有限公司
HUI ZHOU DELI ELECTRONICS CO., LTD

CUSTOMER:	1324	REV NO:	A
DESCRIPTION:	无线充线圈	PAGE NO:	PAGE 6 OF 6
CUST P/N:		SN.	230414424
PART NO:	68IW 44×0.5H-6R7K-FP	DATE:	2023/4/14

7.PACKAGE SPECIFICATION

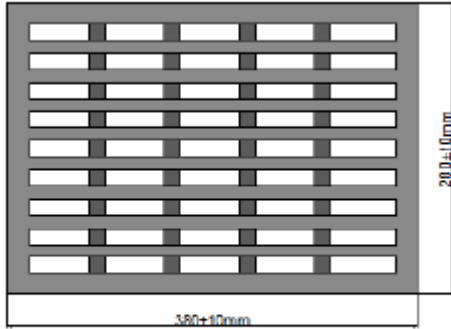

珍珠棉尺寸为：390×280×47mm，
每个珍珠棉有45格，每格装6pcs共270pcs产品。

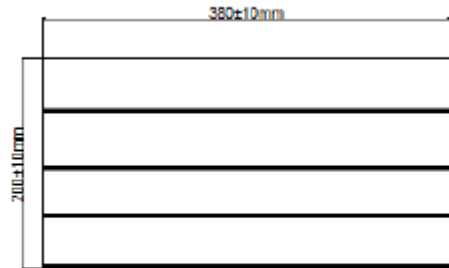

每箱装4层珍珠棉



- 1、每层珍珠棉可装 270pcs 产品；
- 2、每箱可装 4 层珍珠棉，即可装 1080 产品

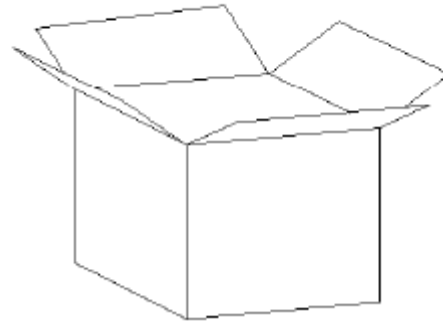

8.REMARK

成品单重:8.03g

特记事项:

此产品为非车规认证产品

APPROVED BY	CHECKED BY	DRAFT
周光军	黄积有	姚慧娟