

# FCC RADIO TEST REPORT

## FCC ID:2AVYC-PANTHEONE1

**Product:** Active speaker  
**Trade Name:** PANTHEONE  
**Model Name:** Pantheone I  
**Serial Model:** N/A  
**Report No.:** UNIA20010610ER-03

### Prepared for

Pantheone Pty Ltd

Level 6,151 Macquarie Street Sydney NSW 2000 Australia

### Prepared by

Shenzhen United Testing Technology Co., Ltd.

2F, Annex Bldg, Jiahuangyuan Tech Park, #365 Baotian 1 Rd, Tiegang Community, Xixiang Str, Bao'an District, Shenzhen, China

### TEST RESULT CERTIFICATION

**Applicant's name**.....: Pantheone Pty Ltd

Address.....: Level 6,151 Macquarie Street Sydney NSW 2000 Australia

**Manufacture's Name**.....: Pantheone Pty Ltd

Address.....: Level 6,151 Macquarie Street Sydney NSW 2000 Australia

**Product description**

Product name.....: Active speaker

Trade Mark.....: PANTHEONE

Model and/or type reference : Pantheone I

**Standards**.....: FCC Rules and Regulations Part 15 Subpart C Section 15.247  
ANSI C63.10: 2013

This device described above has been tested by Shenzhen United Testing Technology Co., Ltd., and the test results show that the equipment under test (EUT) is in compliance with the FCC requirements. And it is applicable only to the tested sample identified in the report.

This report shall not be reproduced except in full, without the written approval of UNI, this document may be altered or revised by Shenzhen United Testing Technology Co., Ltd., personnel only, and shall be noted in the revision of the document.

**Date of Test**.....:

Date (s) of performance of tests.....: Jan. 06, 2020 ~ Mar. 24, 2020

Date of Issue.....: Mar. 24, 2020

Test Result.....: Pass

Prepared by:

Kahn yang/Editor

Reviewer:

Sherwin Qian/Supervisor

Approved & Authorized Signer:

Liuze/Manager

Table of Contents

Page

1. TEST SUMMARY.....	5
2. GENERAL INFORMATION.....	6
2.1 GENERAL DESCRIPTION OF EUT.....	6
2.2 Carrier Frequency of Channels.....	7
2.3 Operation of EUT during testing.....	7
2.4 DESCRIPTION OF TEST SETUP.....	7
2.5 MEASUREMENT INSTRUMENTS LIST.....	8
3. CONDUCTED EMISSIONS TEST.....	9
3.1 Conducted Power Line Emission Limit.....	9
3.2 Test Setup.....	9
3.3 Test Procedure.....	9
3.4 Test Result.....	9
4 RADIATED EMISSION TEST.....	12
4.1 Radiation Limit.....	12
4.2 Test Setup.....	12
4.3 Test Procedure.....	13
4.4 Test Result.....	13
5 BAND EDGE.....	25
5.1 Limits.....	25
5.2 Test Procedure.....	25
5.3 Test Result.....	25
6 OCCUPIED BANDWIDTH MEASUREMENT.....	31
6.1 Test Limit.....	31
6.2 Test Procedure.....	31
6.3 Measurement Equipment Used.....	31
6.4 Test Result.....	31
7 POWER SPECTRAL DENSITY TEST.....	38
7.1 Test Limit.....	38
7.2 Test Procedure.....	38
7.3 Measurement Equipment Used.....	38
7.4 Test Result.....	38
8 PEAK OUTPUT POWER TEST.....	45
8.1 Test Limit.....	45
8.2 Test Procedure.....	45
8.3 Measurement Equipment Used.....	45

## Table of Contents

## Page

8.4 Test Result.....	45
9 OUT OF BAND EMISSIONS TEST.....	46
9.1 Test Limit.....	46
9.2 Test Procedure.....	46
9.3 Test Setup.....	46
9.4 Test Result.....	46
10 ANTENNA REQUIREMENT.....	50
8 PHOTOGRAPH OF TEST.....	51
8.1 Radiated Emission.....	51
8.2 Conducted Emission.....	52

## 1. TEST SUMMARY

### TEST PROCEDURES AND RESULTS

DESCRIPTION OF TEST	RESULT
CONDUCTED EMISSIONS TEST	COMPLIANT FCC Part 15.207
RADIATED EMISSION TEST	COMPLIANT FCC Part 15.209(a)
BAND EDGE	COMPLIANT FCC Part 15.247(d)
OCCUPIED BANDWIDTH MEASUREMENT	COMPLIANT FCC Part 15.247(a)(2)
POWER SPECTRAL DENSITY	COMPLIANT FCC Part 15.247(e)
PEAK OUTPUT POWER	COMPLIANT FCC Part 15.247(b)
OUT OF BAND EMISSIONS	COMPLIANT FCC Part 15.247(d)
ANTENNA REQUIREMENT	COMPLIANT FCC Part 15.203

### TEST FACILITY

Test Firm : Shenzhen United Testing Technology Co., Ltd.  
Address : 2F, Annex Bldg, Jiahuangyuan Tech Park, #365 Baotian 1 Rd, Tiegang Community, Xixiang Str, Bao'an District, Shenzhen, China

The testing quality ability of our laboratory meet with "Quality Law of People's Republic of China" Clause 19. The testing quality system of our laboratory meets with ISO/IEC-17025 requirements. This approval result is accepted by MRA of APLAC.

Our test facility is recognized, certified, or accredited by the following organizations:

A2LA Certificate Number: 4747.01

The EMC Laboratory has been accredited by A2LA, and in compliance with ISO/IEC 17025:2017 General Requirements for testing Laboratories.

FCC Registration Number: 674885

The EMC Laboratory has been registered and fully described in a report filed with the (FCC) Federal Communications commission.

IC Registration Number: 21947

The EMC Laboratory has been registered and fully described in a report filed with the (IC) Industry Canada.

### MEASUREMENT UNCERTAINTY

#### Measurement Uncertainty

Conducted Emission Expanded Uncertainty	=	2.23dB, k=2
Radiated emission expanded uncertainty(9kHz-30MHz)	=	3.08dB, k=2
Radiated emission expanded uncertainty(30MHz-1000MHz)	=	4.42dB, k=2
Radiated emission expanded uncertainty(Above 1GHz)	=	4.06dB, k=2



## 2. GENERAL INFORMATION

### 2.1 GENERAL DESCRIPTION OF EUT

Equipment	Active speaker
Trade Mark	PANTHEONE
Model Name	Pantheone I
Serial No.	N/A
Model Difference	N/A
FCC ID	2AVYC-PANTHEONE1
Antenna Type	Internet Antenna
Antenna Gain	1dBi
Frequency Range	802.11b/g/n20: 2412~2462 MHz
Number of Channels	802.11b/g/n20: 11CH
Modulation Type	CCK, OFDM, DBPSK, DAPSK
Battery	N/A
Power Source	AC 100-240V~50/60Hz

### 2.2 Carrier Frequency of Channels

Channel List for 802.11b/g/n(20MHz)							
Channel	Frequency (MHz)	Channel	Frequency (MHz)	Channel	Frequency (MHz)	Channel	Frequency (MHz)
01	2412	04	2427	07	2442	10	2457
02	2417	05	2432	08	2447	11	2462
03	2422	06	2437	09	2452		

### 2.3 Operation of EUT during testing

Fixed frequency software	Software version	Power level
SecureCRT	CP210X(Command fixed frequency)	13

#### Operating Mode

The mode is used: Transmitting mode for 802.11b/g/n(20MHz)

Low Channel:CH1: 2412MHz

Middle Channel:CH6: 2437MHz

High Channel:CH11: 2462MHz

### 2.4 DESCRIPTION OF TEST SETUP

Operation of EUT during Conducted testing:

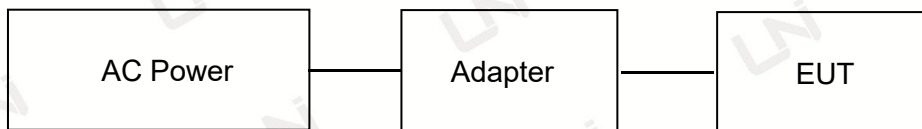

Operation of EUT during Radiation and Above1GHz Radiation testing:

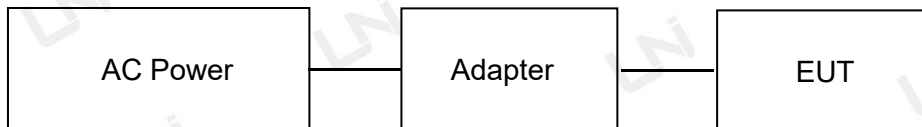

Table for auxiliary equipment:

Equipment Description	Manufacturer	Model	Calibration Due Date
N/A	N/A	N/A	N/A

2.5 MEASUREMENT INSTRUMENTS LIST

Item	Equipment	Manufacturer	Model No.	Serial No.	Calibrated until
Conduction Emissions Measurement					
1	Conducted Emission Test Software	EZ-EMC	Ver.CCS-3A1-CE	N/A	N/A
2	AMN	Schwarzbeck	NNLK8121	8121370	2020.10.15
3	AMN	ETS	3810/2	00020199	2020.10.15
4	AAN	TESEQ	T8-Cat6	38888	2020.10.15
5	Pulse Limiter	CYBRTEK	EM5010	E115010056	2020.05.26
6	EMI Test Receiver	Rohde&Schwarz	ESCI	101210	2020.10.15
Radiated Emissions Measurement					
1	Radiated Emission Test Software	EZ-EMC	Ver.CCS-03A1	N/A	N/A
2	Horn Antenna	Sunol	DRH-118	A101415	2020.10.18
3	Broadband Hybrid Antenna	Sunol	JB1	A090215	2020.11.15
4	PREAMP	HP	8449B	3008A00160	2020.10.21
5	PREAMP	HP	8447D	2944A07999	2020.05.26
6	EMI Test Receiver	Rohde&Schwarz	ESR3	101891	2020.10.15
7	MXA Signal Analyzer	Keysight	N9020A	MY51110104	2020.10.15
8	Active Loop Antenna	Com-Power	AL-310R	10160009	2020.05.28
9	Horn Antenna	Schwarzbeck	BBHA9120D	9120D-1680	2020.05.28
10	Horn Antenna	A-INFOMW	LB-180400-KF	J211060660	2020.10.23
11	Loop Antenna	Beijing daze Technology	ZN30401	13015	2020.10.15
12	EM Clamp	Schwarzbeck	MDS21	03350	2020.10.20



### 3. CONDUCTED EMISSIONS TEST

#### 3.1 Conducted Power Line Emission Limit

For unintentional device, according to § 15.107(a) Line Conducted Emission Limits is as following

Frequency (MHz)	Maximum RF Line Voltage(dBμV)			
	CLASS A		CLASS B	
	Q.P.	Ave.	Q.P.	Ave.
0.15~0.50	79	66	66~56*	56~46*
0.50~5.00	73	60	56	46
5.00~30.0	73	60	60	50

\* Decreasing linearly with the logarithm of the frequency

For intentional device, according to §15.207(a) Line Conducted Emission Limit is same as above table.

#### 3.2 Test Setup

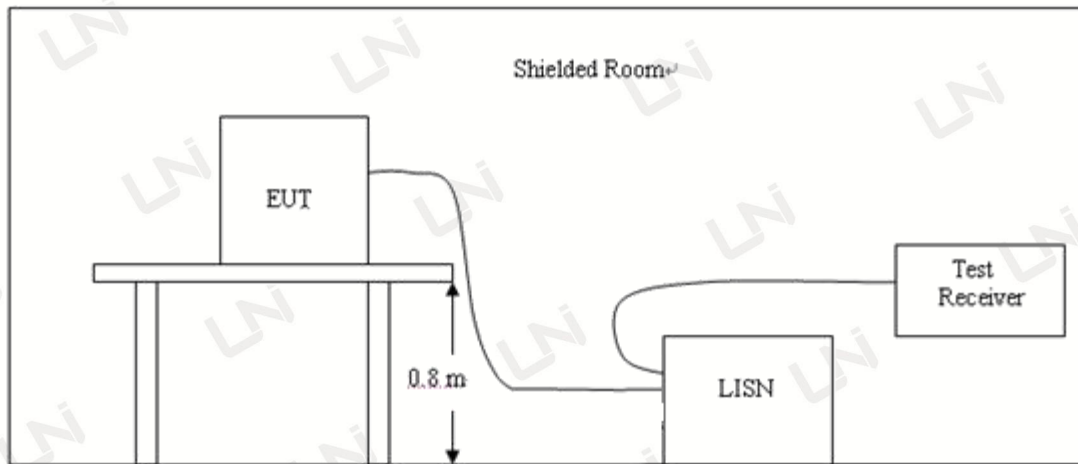

#### 3.3 Test Procedure

- 1, The equipment was set up as per the test configuration to simulate typical actual usage per the user's manual. A wooden table with a height of 0.8 meters is used and is placed on the ground plane as per ANSI C63.10.
- 2, Support equipment, if needed, was placed as per ANSI C63.10.
- 3, All I/O cables were positioned to simulate typical actual usage as per ANSI C63.10.
- 4, If a EUT received DC power from the USB Port of Notebook PC, the PC's adapter received AC120V/60Hz power through a Line Impedance Stabilization Network (LISN) which supplied power source and was grounded to the ground plane.
- 5, All support equipments received AC power from a second LISN, if any.
- 6, The EUT test program was started. Emissions were measured on each current carrying line of the EUT using a spectrum Analyzer / Receiver connected to the LISN powering the EUT. The LISN has two monitoring points: Line 1 (Hot Side) and Line 2 (Neutral Side). Two scans were taken: one with Line 1 connected to Analyzer / Receiver and Line 2 connected to a 50 ohm load; the second scan had Line 1 connected to a 50 ohm load and Line 2 connected to the Analyzer / Receiver.
- 7, Analyzer / Receiver scanned from 150 KHz to 30MHz for emissions in each of the test modes.

#### 3.4 Test Result

Pass

Remark:

1. All modes were tested at AC 120V and 240V, only the worst result of AC 120V was reported.
2. All modes were tested at Low, Middle, and High channel, only the worst result of 802.11b Low Channel was reported as below:

Temperature:	24°C	Relative Humidity:	48%
Test Date:	Mar. 10, 2020	Pressure:	1030hPa
Test Voltage:	AC 120V, 60Hz	Phase:	Line
Test Mode:	Transmitting mode of 802.11b 2412MHz		

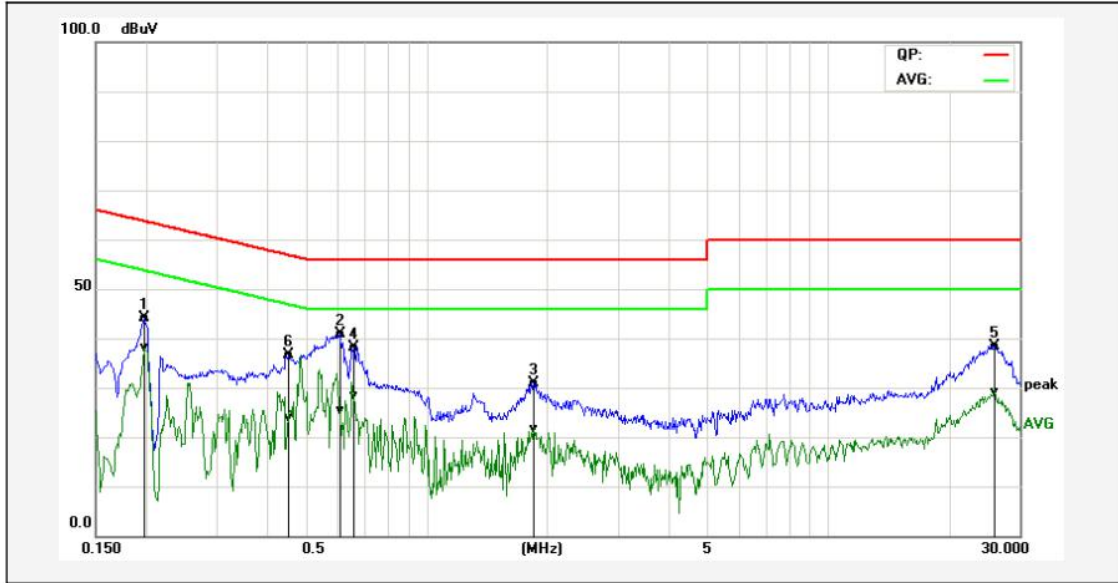

No.	Frequency (MHz)	QuasiPeak reading (dBuV)	Average reading (dBuV)	Correction factor (dB)	QuasiPeak result (dBuV)	Average result (dBuV)	QuasiPeak limit (dBuV)	Average limit (dBuV)	QuasiPeak margin (dB)	Average margin (dB)	Remark
1P	0.1980	44.18	38.18	0.05	44.23	38.23	63.69	53.69	-19.46	-15.46	Pass
2*	0.6100	40.79	25.31	0.05	40.84	25.36	56.00	46.00	-15.16	-20.64	Pass
3P	1.8500	30.91	21.68	0.07	30.98	21.75	56.00	46.00	-25.02	-24.25	Pass
4P	0.6580	38.16	28.34	0.05	38.21	28.39	56.00	46.00	-17.79	-17.61	Pass
5P	25.8860	37.81	28.55	0.68	38.49	29.23	60.00	50.00	-21.51	-20.77	Pass
6P	0.4515	36.57	23.83	0.05	36.62	23.88	56.85	46.85	-20.23	-22.97	Pass

Remark: Factor = Insertion Loss + Cable Loss, Result=Reading + Factor, Margin=Result – Limit.

Temperature:	24°C	Relative Humidity:	48%
Test Date:	Mar. 10, 2020	Pressure:	1030hPa
Test Voltage:	AC 120V, 60Hz	Phase:	Neutral
Test Mode:	Transmitting mode of 802.11b 2412MHz		

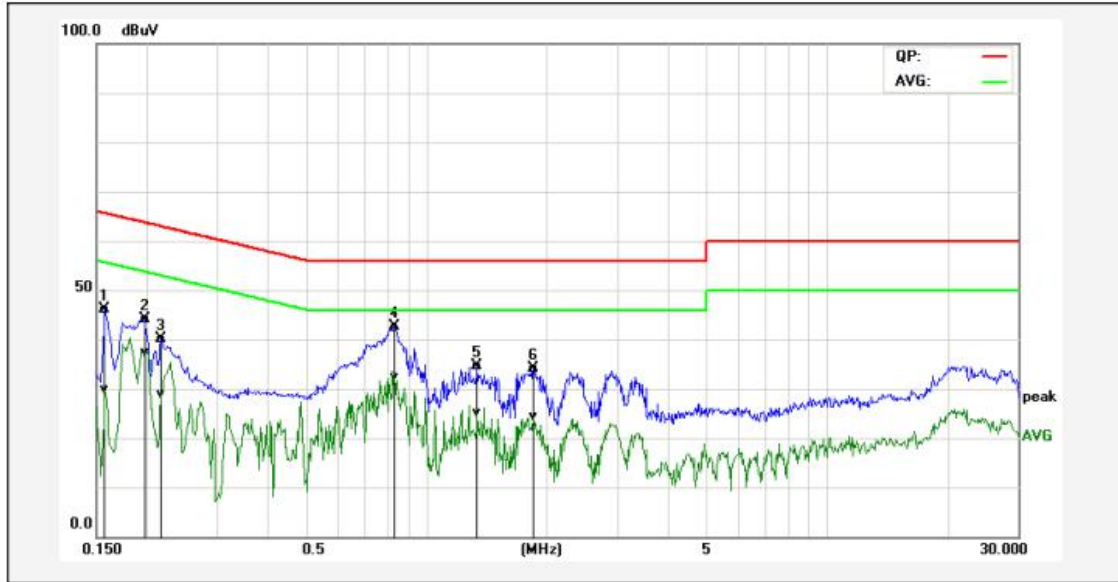

No.	Frequency (MHz)	QuasiPeak reading (dBuV)	Average reading (dBuV)	Correction factor (dB)	QuasiPeak result (dBuV)	Average result (dBuV)	QuasiPeak limit (dBuV)	Average limit (dBuV)	QuasiPeak margin (dB)	Average margin (dB)	Remark
1P	0.1580	46.11	29.78	0.05	46.16	29.83	65.56	55.57	-19.40	-25.74	Pass
2P	0.1980	44.20	37.21	0.05	44.25	37.26	63.69	53.69	-19.44	-16.43	Pass
3P	0.2180	40.20	28.95	0.05	40.25	29.00	62.89	52.89	-22.64	-23.89	Pass
4*	0.8340	42.45	32.35	0.05	42.50	32.40	56.00	46.00	-13.50	-13.60	Pass
5P	1.3380	34.46	25.04	0.06	34.52	25.10	56.00	46.00	-21.48	-20.90	Pass
6P	1.8500	33.94	24.22	0.07	34.01	24.29	56.00	46.00	-21.99	-21.71	Pass

Remark: Factor = Insertion Loss + Cable Loss, Result=Reading + Factor, Margin=Result – Limit.

## 4 RADIATED EMISSION TEST

### 4.1 Radiation Limit

For unintentional device, according to § 15.109(a), except for Class A digital devices, the field strength of radiated emissions from unintentional radiators at a distance of 3 meters shall not exceed the following values:

Frequency (MHz)	Distance (Meters)	Radiated (dB $\mu$ V/m)	Radiated ( $\mu$ V/m)
30-88	3	40	100
88-216	3	43.5	150
216-960	3	46	200
Above 960	3	54	500

For intentional device, according to § 15.209(a), the general requirement of field strength of radiated emissions from intentional radiators at a distance of 3 meters shall not exceed the above table.

### 4.2 Test Setup

#### 1. Radiated Emission Test-Up Frequency Below 30MHz

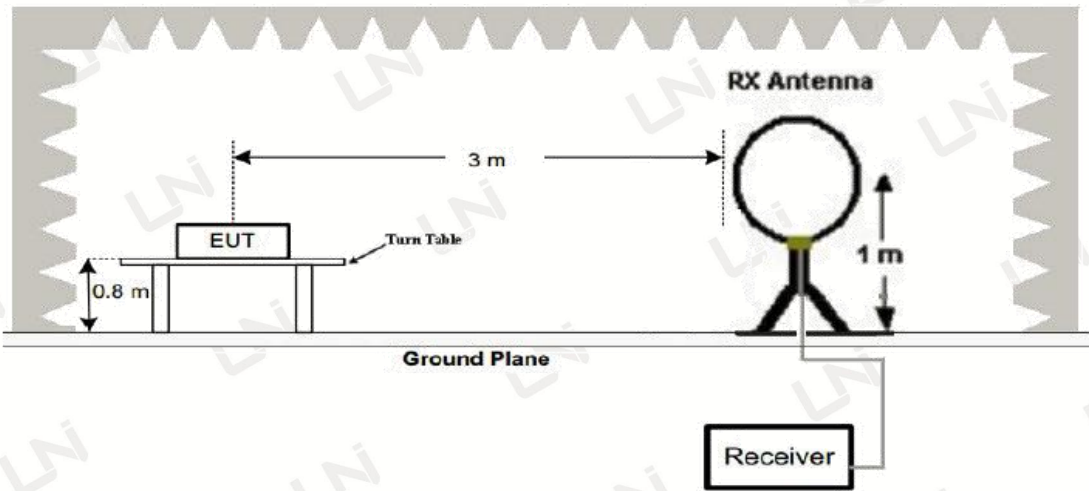

#### 2. Radiated Emission Test-Up Frequency 30MHz~1GHz

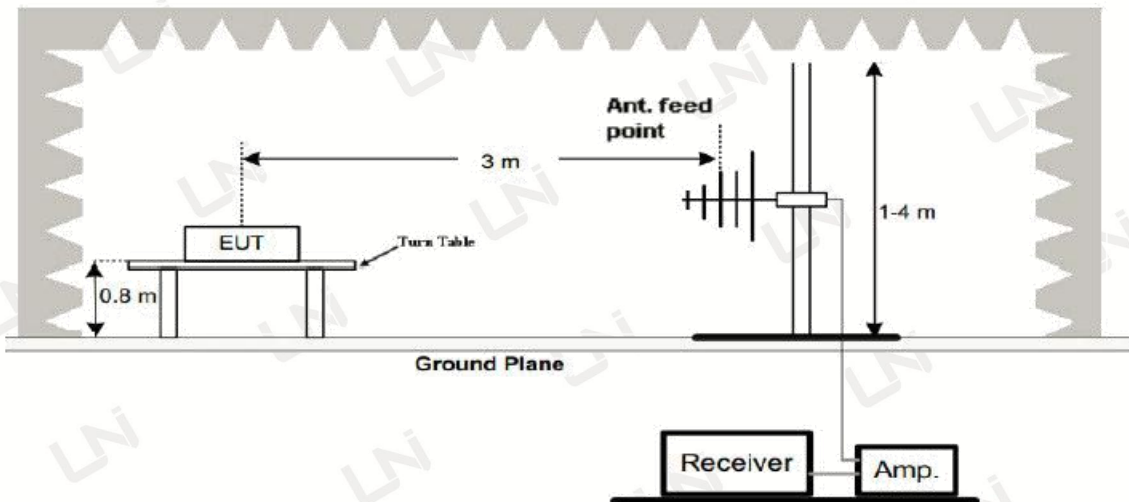



### 3. Radiated Emission Test-Up Frequency Above 1GHz

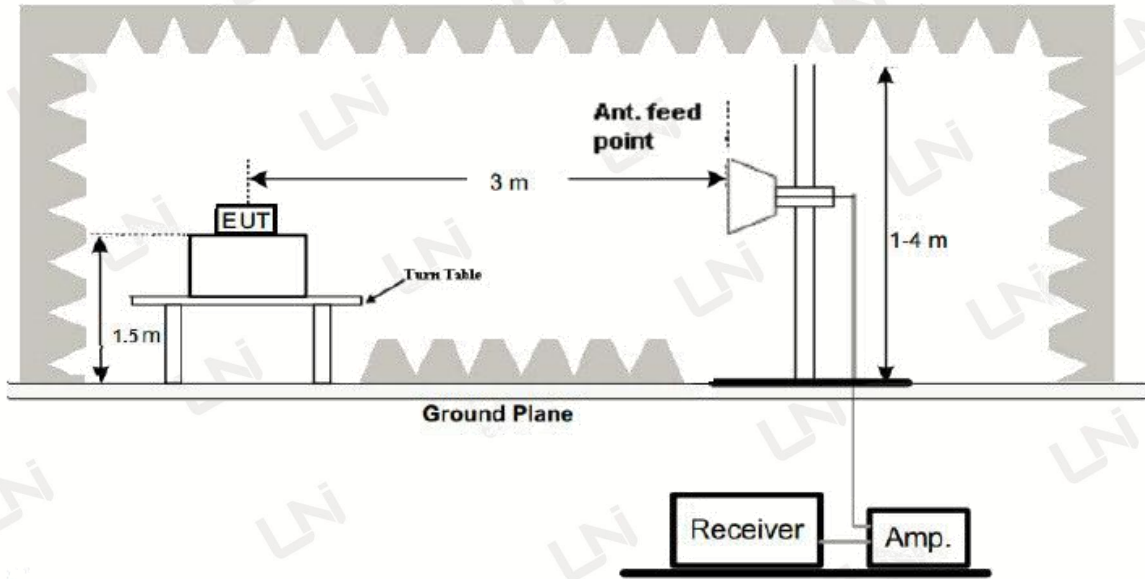

#### 4.3 Test Procedure

1. Below 1GHz measurement the EUT is placed on turntable which is 0.8m above ground plane. And above 1GHz measurement EUT was placed on low permittivity and low tangent turn table which is 1.5m above ground plane.
2. The turntable shall be rotated for 360 degrees to determine the position of maximum emission level.
3. EUT is set 3m away from the receiving antenna, which is varied from 1m to 4m to find out the highest emissions.
4. Maximum procedure was performed on the six highest emissions to ensure EUT compliance.
5. And also, each emission was to be maximized by changing the polarization of receiving antenna both horizontal and vertical.
6. Repeat above procedures until the measurements for all frequencies are complete.
7. The test frequency range from 9KHz to 25GHz per FCC PART 15.33(a).

**Note:**

For battery operated equipment, the equipment tests shall be performed using a new battery.

#### 4.4 Test Result

**PASS**

**Remark:**

1. All modes of 802.11b/g/n20/n40 were test at Low, Middle, and High channel, only the worst result of 802.11b High Channel was reported for below 1GHz test.
2. By preliminary testing and verifying three axis (X, Y and Z) position of EUT transmitted status, it was found that "Z axis" position was the worst, and test data recorded in this report.



Below 1GHz Test Results:

Temperature:	24°C	Relative Humidity:	48%
Test Date:	Mar. 10, 2020	Pressure:	1030hPa
Test Voltage:	AC 120V, 60Hz	Polarization:	Horizontal
Test Mode:	Transmitting mode of 802.11b 2462MHz		

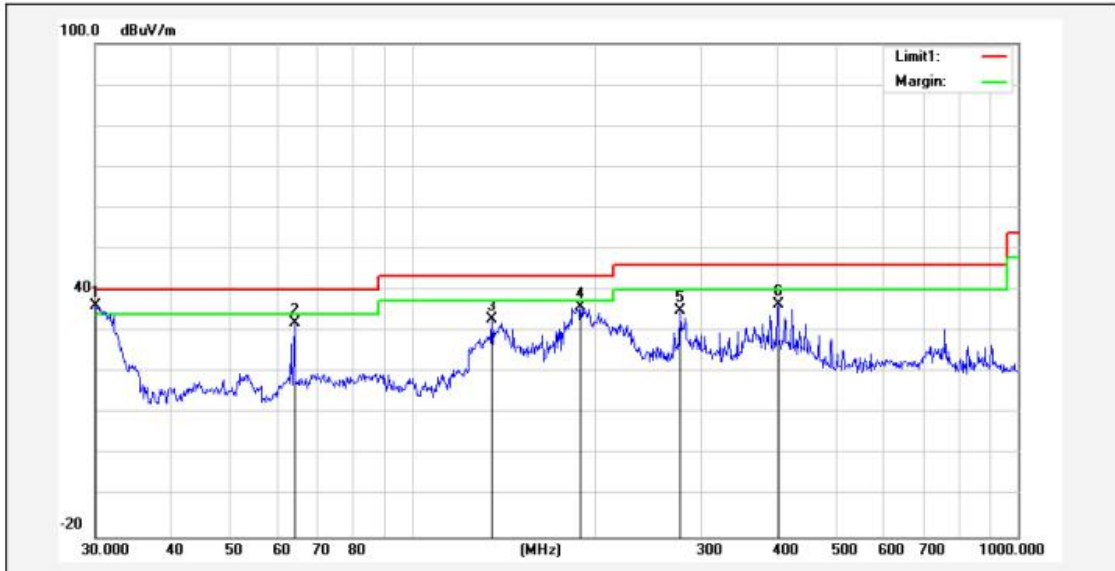

No.	Frequency (MHz)	Reading (dBuV)	Correction factor(dB/m)	Result (dBuV/m)	Limit (dBuV/m)	Margin (dB)	Degree (deg.)	Height (cm)	Remark
1*	30.1052	43.49	-7.23	36.26	40.00	-3.74	120	100	peak
2	63.9827	53.63	-21.55	32.08	40.00	-7.92	300	100	peak
3	135.5062	49.44	-16.41	33.03	43.50	-10.47	60	100	peak
4	189.7384	53.96	-18.03	35.93	43.50	-7.57	360	100	peak
5	277.0935	50.39	-15.27	35.12	46.00	-10.88	240	100	peak
6	401.8385	49.41	-12.84	36.57	46.00	-9.43	120	100	peak

Remark: Absolute Level = Reading Level + Factor, Margin = Absolute Level – Limit  
 Factor = Ant. Factor + Cable Loss – Pre-amplifier

Temperature:	24°C	Relative Humidity:	48%
Test Date:	Mar. 10, 2020	Pressure:	1030hPa
Test Voltage:	AC 120V, 60Hz	Polarization:	Vertical
Test Mode:	Transmitting mode of 802.11b 2462MHz		

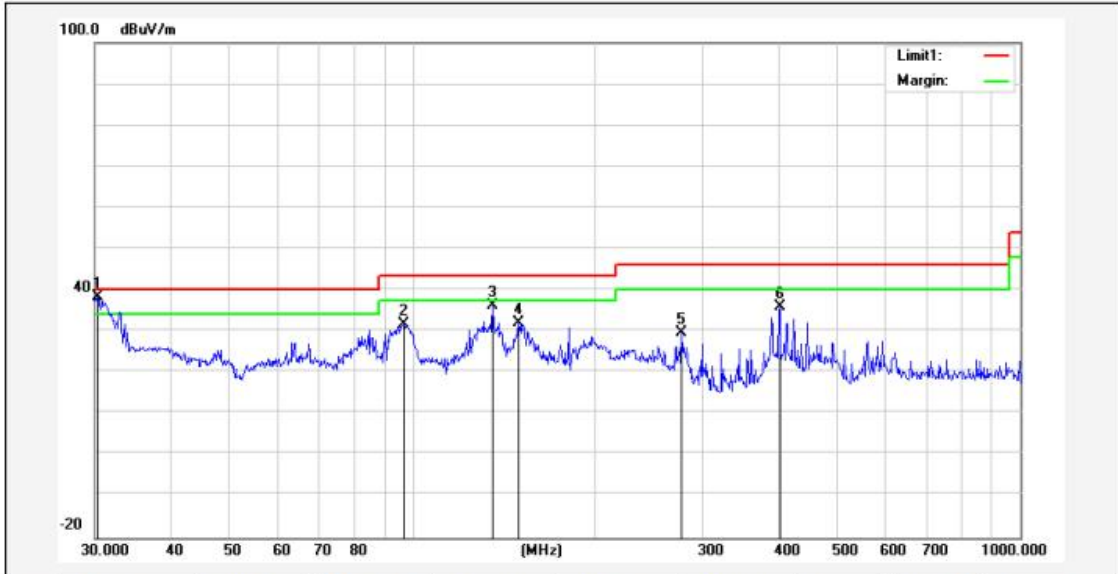

No.	Frequency (MHz)	Reading (dBuV)	Correction factor(dB/m)	Result (dBuV/m)	Limit (dBuV/m)	Margin (dB)	Degree (deg.)	Height (cm)	Remark
1*	30.3172	45.60	-7.40	38.20	40.00	-1.80	90	100	peak
2	96.7750	51.42	-19.79	31.63	43.50	-11.87	180	100	peak
3	135.5062	52.75	-16.41	36.34	43.50	-7.16	270	100	peak
4	149.4857	49.41	-17.35	32.06	43.50	-11.44	150	100	peak
5	277.0935	45.05	-15.27	29.78	46.00	-16.22	300	100	peak
6	401.8385	48.92	-12.84	36.08	46.00	-9.92	330	100	peak

Remark: Absolute Level = Reading Level + Factor, Margin = Absolute Level – Limit  
 Factor = Ant. Factor + Cable Loss – Pre-amplifier

Remark:

- (1) Measuring frequencies from 9 KHz to the 1 GHz, radiated emission test from 9KHz to 30MHz was verified, and no any emission was found except system noise floor.
- (2) \* denotes emission frequency which appearing within the Restricted Bands specified in provision of 15.205, then the general radiated emission limits in 15.209 apply.
- (3) The IF bandwidth of EMI Test Receiver between 30MHz to 1GHz was 120KHz, 1 MHz for measuring above 1 GHz, below 30MHz was 10KHz.

Above 1 GHz Test Results:

CH Low of 802.11b Mode (2412MHz)

Horizontal:

Frequency (MHz)	Reading Result (dBμV)	Factor (dB)	Emission Level (dBμV/m)	Limits (dBμV/m)	Margin (dB)	Detector Type
4824	61.85	-3.64	58.21	74	-15.79	PK
4824	51.36	-3.64	47.72	54	-6.28	AV
7236	58.67	-0.95	57.72	74	-16.28	PK
7236	47.31	-0.95	46.36	54	-7.64	AV

Remark: Factor = Antenna Factor + Cable Loss – Pre-amplifier. Margin = Absolute Level – Limit

Vertical:

Frequency (MHz)	Reading Result (dBμV)	Factor (dB)	Emission Level (dBμV/m)	Limits (dBμV/m)	Margin (dB)	Detector Type
4824	62.39	-3.64	58.75	74	-15.25	PK
4824	50.34	-3.64	46.70	54	-7.30	AV
7236	58.32	-0.95	57.37	74	-16.63	PK
7236	47.82	-0.95	46.87	54	-7.13	AV

Remark: Factor = Antenna Factor + Cable Loss – Pre-amplifier. Margin = Absolute Level – Limit

CH Middle of 802.11b Mode (2437MHz)

Horizontal:

Frequency (MHz)	Reading Result (dBμV)	Factor (dB)	Emission Level (dBμV/m)	Limits (dBμV/m)	Margin (dB)	Detector Type
4874	61.99	-3.51	58.48	74	-15.52	PK
4874	52.34	-3.51	48.83	54	-5.17	AV
7311	58.00	-0.82	57.18	74	-16.82	PK
7311	47.34	-0.82	46.52	54	-7.48	AV

Remark: Factor = Antenna Factor + Cable Loss – Pre-amplifier. Margin = Absolute Level – Limit

Vertical:

Frequency (MHz)	Reading Result (dBμV)	Factor (dB)	Emission Level (dBμV/m)	Limits (dBμV/m)	Margin (dB)	Detector Type
4874	61.34	-3.51	57.83	74	-16.17	PK
4874	50.38	-3.51	46.87	54	-7.13	AV
7311	58.02	-0.82	57.2	74	-16.8	PK
7311	47.39	-0.82	46.57	54	-7.43	AV

Remark: Factor = Antenna Factor + Cable Loss – Pre-amplifier. Margin = Absolute Level – Limit



CH High of 802.11b Mode (2462MHz)

Horizontal:

Frequency	Reading Result	Factor	Emission Level	Limits	Margin	Detector
(MHz)	(dBμV)	(dB)	(dBμV/m)	(dBμV/m)	(dB)	Type
4924	61.35	-3.43	57.92	74	-16.08	PK
4924	50.39	-3.43	46.96	54	-7.04	AV
7386	58.34	-0.75	57.59	74	-16.41	PK
7386	47.35	-0.75	46.60	54	-7.40	AV

Remark: Factor = Antenna Factor + Cable Loss – Pre-amplifier. Margin = Absolute Level – Limit

Vertical:

Frequency	Reading Result	Factor	Emission Level	Limits	Margin	Detector
(MHz)	(dBμV)	(dB)	(dBμV/m)	(dBμV/m)	(dB)	Type
4924	61.46	-3.43	58.03	74	-15.97	PK
4924	50.69	-3.43	47.26	54	-6.74	AV
7386	57.31	-0.75	56.56	74	-17.44	PK
7386	47.81	-0.75	47.06	54	-6.94	AV

Remark: Factor = Antenna Factor + Cable Loss – Pre-amplifier. Margin = Absolute Level – Limit

Remark:

- (1) Measuring frequencies from 1 GHz to the 25 GHz.
- (2) "F" denotes fundamental frequency; "H" denotes spurious frequency. "E" denotes band edge frequency.
- (3) \* denotes emission frequency which appearing within the Restricted Bands specified in provision of 15.205, then the general radiated emission limits in 15.209 apply.
- (4) Data of measurement within this frequency range ,that the value more than 20dB below limit is not record in the form.
- (5) The IF bandwidth of EMI Test Receiver between 30MHz to 1GHz was 120KHz, 1 MHz for measuring above 1 GHz, below 30MHz was 10KHz. The resolution bandwidth of test receiver/spectrum analyzer is 1MHz and video bandwidth is 3MHz for peak measurement with peak detector at frequency above 1GHz. The resolution bandwidth of test receiver/spectrum analyzer is 1MHz and video bandwidth is 10Hz for Average measurement with peak detection at frequency above 1GHz.
- (6) When the test results of Peak Detected below the limits of Average Detected, the Average Detected is not need completed. For example: Top Channel at Fundamental 73.16dBuV/m(PK Value) <93.98(AV Limit), at harmonic 53.20 dBuV/m(PK Value) <54 dBuV/m(AV Limit), the Average Detected not need to completed.



CH Low of 802.11g Mode (2412MHz)

Horizontal:

Frequency (MHz)	Reading Result (dBμV)	Factor (dB)	Emission Level (dBμV/m)	Limits (dBμV/m)	Margin (dB)	Detector Type
4824	62.07	-3.64	58.43	74	-15.57	PK
4824	51.37	-3.64	47.73	54	-6.27	AV
7236	57.02	-0.95	56.07	74	-17.93	PK
7236	47.33	-0.95	46.38	54	-7.62	AV

Remark: Factor = Antenna Factor + Cable Loss – Pre-amplifier. Margin = Absolute Level – Limit

Vertical:

Frequency (MHz)	Reading Result (dBμV)	Factor (dB)	Emission Level (dBμV/m)	Limits (dBμV/m)	Margin (dB)	Detector Type
4824	62.14	-3.64	58.50	74	-15.50	PK
4824	51.08	-3.64	47.44	54	-6.56	AV
7236	57.69	-0.95	56.74	74	-17.26	PK
7236	47.34	-0.95	46.39	54	-7.61	AV

Remark: Factor = Antenna Factor + Cable Loss – Pre-amplifier. Margin = Absolute Level – Limit

CH Middle of 802.11g Mode (2437MHz)

Horizontal:

Frequency (MHz)	Reading Result (dBμV)	Factor (dB)	Emission Level (dBμV/m)	Limits (dBμV/m)	Margin (dB)	Detector Type
4874	62.81	-3.51	59.30	74	-14.70	PK
4874	51.06	-3.51	47.55	54	-6.45	AV
7311	58.34	-0.82	57.52	74	-16.48	PK
7311	47.39	-0.82	46.57	54	-7.43	AV

Remark: Factor = Antenna Factor + Cable Loss – Pre-amplifier. Margin = Absolute Level – Limit

Vertical:

Frequency (MHz)	Reading Result (dBμV)	Factor (dB)	Emission Level (dBμV/m)	Limits (dBμV/m)	Margin (dB)	Detector Type
4874	61.31	-3.51	57.80	74	-16.20	PK
4874	50.39	-3.51	46.88	54	-7.12	AV
7311	58.22	-0.82	57.4	74	-16.6	PK
7311	47.35	-0.82	46.53	54	-7.47	AV

Remark: Factor = Antenna Factor + Cable Loss – Pre-amplifier. Margin = Absolute Level – Limit

CH High of 802.11g Mode (2462MHz)

Horizontal:

Frequency	Reading Result	Factor	Emission Level	Limits	Margin	Detector
(MHz)	(dBμV)	(dB)	(dBμV/m)	(dBμV/m)	(dB)	Type
4924	61.51	-3.43	58.08	74	-15.92	PK
4924	50.67	-3.43	47.24	54	-6.76	AV
7386	58.61	-0.75	57.86	74	-16.14	PK
7386	47.88	-0.75	47.13	54	-6.87	AV

Remark: Factor = Antenna Factor + Cable Loss – Pre-amplifier. Margin = Absolute Level – Limit

Vertical:

Frequency	Reading Result	Factor	Emission Level	Limits	Margin	Detector
(MHz)	(dBμV)	(dB)	(dBμV/m)	(dBμV/m)	(dB)	Type
4924	62.31	-3.43	58.88	74	-15.12	PK
4924	50.89	-3.43	47.46	54	-6.54	AV
7386	57.67	-0.75	56.92	74	-17.08	PK
7386	47.55	-0.75	46.80	54	-7.20	AV

Remark: Factor = Antenna Factor + Cable Loss – Pre-amplifier. Margin = Absolute Level – Limit

Remark:

- (1) Measuring frequencies from 1 GHz to the 25 GHz.
- (2) "F" denotes fundamental frequency; "H" denotes spurious frequency. "E" denotes band edge frequency.
- (3) \* denotes emission frequency which appearing within the Restricted Bands specified in provision of 15.205, then the general radiated emission limits in 15.209 apply.
- (4) Data of measurement within this frequency range ,that the value more than 20dB below limit is not record in the form.
- (5) The IF bandwidth of EMI Test Receiver between 30MHz to 1GHz was 120KHz, 1 MHz for measuring above 1 GHz, below 30MHz was 10KHz. The resolution bandwidth of test receiver/spectrum analyzer is 1MHz and video bandwidth is 3MHz for peak measurement with peak detector at frequency above 1GHz. The resolution bandwidth of test receiver/spectrum analyzer is 1MHz and video bandwidth is 10Hz for Average measurement with peak detection at frequency above 1GHz.
- (6) When the test results of Peak Detected below the limits of Average Detected, the Average Detected is not need completed. For example: Top Channel at Fundamental 73.16dBuV/m(PK Value) <93.98(AV Limit), at harmonic 53.20 dBuV/m(PK Value) <54 dBuV/m(AV Limit), the Average Detected not need to completed.

CH Low of 802.11n/H20 Mode (2412MHz)

Horizontal:

Frequency (MHz)	Reading Result (dBμV)	Factor (dB)	Emission Level (dBμV/m)	Limits (dBμV/m)	Margin (dB)	Detector Type
4824	62.03	-3.64	58.39	74	-15.61	PK
4824	50.37	-3.64	46.73	54	-7.27	AV
7236	57.46	-0.95	56.51	74	-17.49	PK
7236	47.38	-0.95	46.43	54	-7.57	AV

Remark: Factor = Antenna Factor + Cable Loss – Pre-amplifier. Margin = Absolute Level – Limit

Vertical:

Frequency (MHz)	Reading Result (dBμV)	Factor (dB)	Emission Level (dBμV/m)	Limits (dBμV/m)	Margin (dB)	Detector Type
4824	61.38	-3.64	57.74	74	-16.26	PK
4824	50.46	-3.64	46.82	54	-7.18	AV
7236	58.06	-0.95	57.11	74	-16.89	PK
7236	47.61	-0.95	46.66	54	-7.34	AV

Remark: Factor = Antenna Factor + Cable Loss – Pre-amplifier. Margin = Absolute Level – Limit

CH Middle of 802.11n/H20 Mode (2437MHz)

Horizontal:

Frequency (MHz)	Reading Result (dBμV)	Factor (dB)	Emission Level (dBμV/m)	Limits (dBμV/m)	Margin (dB)	Detector Type
4874	62.03	-3.51	58.52	74	-15.48	PK
4874	51.06	-3.51	47.55	54	-6.45	AV
7311	57.39	-0.82	56.57	74	-17.43	PK
7311	47.35	-0.82	46.53	54	-7.47	AV

Remark: Factor = Antenna Factor + Cable Loss – Pre-amplifier. Margin = Absolute Level – Limit

Vertical:

Frequency (MHz)	Reading Result (dBμV)	Factor (dB)	Emission Level (dBμV/m)	Limits (dBμV/m)	Margin (dB)	Detector Type
4874	62.34	-3.51	58.83	74	-15.17	PK
4874	50.31	-3.51	46.80	54	-7.20	AV
7311	57.69	-0.82	56.87	74	-17.13	PK
7311	47.35	-0.82	46.53	54	-7.47	AV

Remark: Factor = Antenna Factor + Cable Loss – Pre-amplifier. Margin = Absolute Level – Limit



CH High of 802.11n/H20 Mode (2462MHz)

Horizontal:

Frequency	Reading Result	Factor	Emission Level	Limits	Margin	Detector
(MHz)	(dBμV)	(dB)	(dBμV/m)	(dBμV/m)	(dB)	Type
4924	61.37	-3.43	57.94	74	-16.06	PK
4924	50.64	-3.43	47.21	54	-6.79	AV
7386	57.81	-0.75	57.06	74	-16.94	PK
7386	47.77	-0.75	47.02	54	-6.98	AV

Remark: Factor = Antenna Factor + Cable Loss – Pre-amplifier. Margin = Absolute Level – Limit

Vertical:

Frequency	Reading Result	Factor	Emission Level	Limits	Margin	Detector
(MHz)	(dBμV)	(dB)	(dBμV/m)	(dBμV/m)	(dB)	Type
4924	60.89	-3.43	57.46	74	-16.54	PK
4924	48.69	-3.43	45.26	54	-8.74	AV
7386	57.26	-0.75	56.51	74	-17.49	PK
7386	47.31	-0.75	46.56	54	-7.44	AV

Remark: Factor = Antenna Factor + Cable Loss – Pre-amplifier. Margin = Absolute Level – Limit

Remark:

- (1) Measuring frequencies from 1 GHz to the 25 GHz.
- (2) "F" denotes fundamental frequency; "H" denotes spurious frequency. "E" denotes band edge frequency.
- (3) \* denotes emission frequency which appearing within the Restricted Bands specified in provision of 15.205, then the general radiated emission limits in 15.209 apply.
- (4) Data of measurement within this frequency range ,that the value more than 20dB below limit is not record in the form.
- (5) The IF bandwidth of EMI Test Receiver between 30MHz to 1GHz was 120KHz, 1 MHz for measuring above 1 GHz, below 30MHz was 10KHz. The resolution bandwidth of test receiver/spectrum analyzer is 1MHz and video bandwidth is 3MHz for peak measurement with peak detector at frequency above 1GHz. The resolution bandwidth of test receiver/spectrum analyzer is 1MHz and video bandwidth is 10Hz for Average measurement with peak detection at frequency above 1GHz.
- (6) When the test results of Peak Detected below the limits of Average Detected, the Average Detected is not need completed. For example: Top Channel at Fundamental 73.16dBuV/m(PK Value) <93.98(AV Limit), at harmonic 53.20 dBuV/m(PK Value) <54 dBuV/m(AV Limit), the Average Detected not need to completed.

## 5 BAND EDGE

### 5.1 Limits

FCC PART 15.247 Emissions radiated outside of the specified frequency bands, except for harmonics, shall be attenuated by at least 50 dB below the level of the fundamental or to the general radiated emission limits in §15.209, whichever is the lesser attenuation.

### 5.2 Test Procedure

The band edge compliance of RF radiated emission should be measured by following the guidance in ANSIC63.10 with respect to maximizing the emission by rotating the EUT, measuring the emission while the EUT is situated in three orthogonal planes (if appropriate), adjusting the measurement antenna height and polarization etc. Set RBW to 1MHz and VBM to 3MHz to measure the peak field strength and set RMS detector to measure the average radiated field strength. The conducted RF band edge was measured by using a spectrum analyzer. Set span wide enough to capture the highest in-band emission and the emission at the band edge. Set RBW to 100 KHz and VBW to 300 KHz, to measure the conducted peak band edge.

### 5.3 Test Result

PASS

Operation Mode: 802.11b Mode TX CH Low (2412MHz)

Horizontal:

Frequency (MHz)	Reading Result (dBμV)	Factor (dB)	Emission Level (dBμV/m)	Limits (dBμV/m)	Margin (dB)	Detector Type
2310	55.37	-5.81	49.56	74	-24.44	PK
2310	/	-5.81	/	54	/	AV
2390	64.37	-5.84	58.53	74	-15.47	PK
2390	48.31	-5.84	42.47	54	-11.53	AV
2400	65.29	-5.84	59.45	74	-14.55	PK
2400	49.55	-5.84	43.71	54	-10.29	AV

Remark: Factor = Antenna Factor + Cable Loss – Pre-amplifier. Margin = Reading result + Factor - Limits

Vertical:

Frequency (MHz)	Reading Result (dBμV)	Factor (dB)	Emission Level (dBμV/m)	Limits (dBμV/m)	Margin (dB)	Detector Type
2310	56.37	-5.81	50.56	74	-23.44	PK
2310	/	-5.81	/	54	/	AV
2390	64.21	-5.84	58.37	74	-15.63	PK
2390	47.38	-5.84	41.54	54	-12.46	AV
2400	65.29	-5.84	59.45	74	-14.55	PK
2400	50.37	-5.84	44.53	54	-9.47	AV

Remark: Factor = Antenna Factor + Cable Loss – Pre-amplifier. Margin = Reading result + Factor - Limits

Operation Mode: 802.11b Mode TX CH High (2462MHz)

Horizontal:

Frequency	Reading Result	Factor	Emission Level	Limits	Margin	Detector Type
(MHz)	(dBμV)	(dB)	(dBμV/m)	(dBμV/m)	(dB)	
2483.5	57.29	-5.65	51.64	74	-22.36	PK
2483.5	/	-5.65	/	54	/	AV
2500	55.11	-5.72	49.39	74	-24.61	PK
2500	/	-5.72	/	54	/	AV

Remark: Factor = Antenna Factor + Cable Loss – Pre-amplifier. Margin=Reading result+Factor-Limits

Vertical:

Frequency	Reading Result	Factor	Emission Level	Limits	Margin	Detector Type
(MHz)	(dBμV)	(dB)	(dBμV/m)	(dBμV/m)	(dB)	
2483.5	56.31	-5.65	50.66	74	-23.34	PK
2483.5	/	-5.65	/	54	/	AV
2500	55.61	-5.72	49.89	74	-24.11	PK
2500	/	-5.72	/	54	/	AV

Remark: Factor = Antenna Factor + Cable Loss – Pre-amplifier. Margin=Reading result+Factor-Limits

Operation Mode: 802.11g Mode TX CH Low (2412MHz)

Horizontal:

Frequency (MHz)	Reading Result (dBμV)	Factor (dB)	Emission Level (dBμV/m)	Limits (dBμV/m)	Margin (dB)	Detector Type
2310	56.21	-5.81	50.40	74	-23.60	PK
2310	/	-5.81	/	54	/	AV
2390	63.58	-5.84	57.74	74	-16.26	PK
2390	48.22	-5.84	42.38	54	-11.62	AV
2400	64.44	-5.84	58.60	74	-15.40	PK
2400	50.39	-5.84	44.55	54	-9.45	AV

Remark: Factor = Antenna Factor + Cable Loss – Pre-amplifier. Margin=Reading result+Factor-Limits

Vertical:

Frequency (MHz)	Reading Result (dBμV)	Factor (dB)	Emission Level (dBμV/m)	Limits (dBμV/m)	Margin (dB)	Detector Type
2310	56.27	-5.81	50.46	74	-23.54	PK
2310	/	-5.81	/	54	/	AV
2390	66.34	-5.84	60.50	74	-13.50	PK
2390	47.39	-5.84	41.55	54	-12.45	AV
2400	67.21	-5.84	61.37	74	-12.63	PK
2400	50.32	-5.84	44.48	54	-9.52	AV

Remark: Factor = Antenna Factor + Cable Loss – Pre-amplifier. Margin=Reading result+Factor-Limits

Operation Mode: 802.11g Mode TX CH High (2462MHz)

Horizontal:

Frequency	Reading Result	Factor	Emission Level	Limits	Margin	Detector Type
(MHz)	(dBμV)	(dB)	(dBμV/m)	(dBμV/m)	(dB)	
2483.5	57.02	-5.65	51.37	74	-22.63	PK
2483.5	/	-5.65	/	54	/	AV
2500	55.99	-5.72	50.27	74	-23.73	PK
2500	/	-5.72	/	54	/	AV

Remark: Factor = Antenna Factor + Cable Loss – Pre-amplifier. Margin=Reading result+Factor-Limits

Vertical:

Frequency	Reading Result	Factor	Emission Level	Limits	Margin	Detector Type
(MHz)	(dBμV)	(dB)	(dBμV/m)	(dBμV/m)	(dB)	
2483.5	56.81	-5.65	51.16	74	-22.84	PK
2483.5	/	-5.65	/	54	/	AV
2500	55.34	-5.72	49.62	74	-24.38	PK
2500	/	-5.72	/	54	/	AV

Remark: Factor = Antenna Factor + Cable Loss – Pre-amplifier. Margin=Reading result+Factor-Limits



Operation Mode: 802.11n/H20 Mode TX CH Low (2412MHz)

Horizontal:

Frequency (MHz)	Reading Result (dBμV)	Factor (dB)	Emission Level (dBμV/m)	Limits (dBμV/m)	Margin (dB)	Detector Type
2310	56.38	-5.81	50.57	74	-23.43	PK
2310	/	-5.81	/	54	/	AV
2390	64.37	-5.84	58.53	74	-15.47	PK
2390	49.25	-5.84	43.41	54	-10.59	AV
2400	65.29	-5.84	59.45	74	-14.55	PK
2400	50.31	-5.84	44.47	54	-9.53	AV

Remark: Factor = Antenna Factor + Cable Loss – Pre-amplifier. Margin=Reading result+Factor-Limits

Vertical:

Frequency (MHz)	Reading Result (dBμV)	Factor (dB)	Emission Level (dBμV/m)	Limits (dBμV/m)	Margin (dB)	Detector Type
2310	56.19	-5.81	50.38	74	-23.62	PK
2310	/	-5.81	/	54	/	AV
2390	64.25	-5.84	58.41	74	-15.59	PK
2390	49.27	-5.84	43.43	54	-10.57	AV
2400	65.37	-5.84	59.53	74	-14.47	PK
2400	50.24	-5.84	44.40	54	-9.60	AV

Remark: Factor = Antenna Factor + Cable Loss – Pre-amplifier. Margin=Reading result+Factor-Limits

Operation Mode: 802.11n/H20 Mode TX CH High (2462MHz)

Horizontal:

Frequency	Reading Result	Factor	Emission Level	Limits	Margin	Detector Type
(MHz)	(dBμV)	(dB)	(dBμV/m)	(dBμV/m)	(dB)	
2483.5	58.62	-5.65	52.97	74	-21.03	PK
2483.5	/	-5.65	/	54	/	AV
2500	56.21	-5.72	50.49	74	-23.51	PK
2500	/	-5.72	/	54	/	AV

Remark: Factor = Antenna Factor + Cable Loss – Pre-amplifier. Margin=Reading result+Factor-Limits

Vertical:

Frequency	Reading Result	Factor	Emission Level	Limits	Margin	Detector Type
(MHz)	(dBμV)	(dB)	(dBμV/m)	(dBμV/m)	(dB)	
2483.5	57.46	-5.65	51.81	74	-22.19	PK
2483.5	/	-5.65	/	54	/	AV
2500	56.34	-5.72	50.62	74	-23.38	PK
2500	/	-5.72	/	54	/	AV

Remark: Factor = Antenna Factor + Cable Loss – Pre-amplifier. Margin=Reading result+Factor-Limits

## 6 OCCUPIED BANDWIDTH MEASUREMENT

### 6.1 Test Limit

FCC Part15(15.247), Subpart C				
Section	Test Item	Limit	Frequency Range (MHz)	Result
15.247(a)(2)	Bandwidth	$\geq 500\text{KHz}$ (6dB bandwidth)	2400-2483.5	PASS

### 6.2 Test Procedure

1. The EUT was placed on a turn table which is 0.8m above ground plane.
2. Set EUT as normal operation.
3. Based on FCC Part15 C Section 15.247: RBW=100KHz, VBW=300KHz.
4. The useful radiated emission from the EUT was detected by the spectrum analyzer with peak detector.

### 6.3 Measurement Equipment Used

Same as Radiated Emission Measurement

### 6.4 Test Result

PASS

TX 802.11b Mode			
Frequency (MHz)	6dB Bandwidth (MHz)	Channel Separation (MHz)	Result
2412	9.006	>=500KHz	PASS
2437	9.021	>=500KHz	PASS
2462	9.033	>=500KHz	PASS

CH: 2412MHz

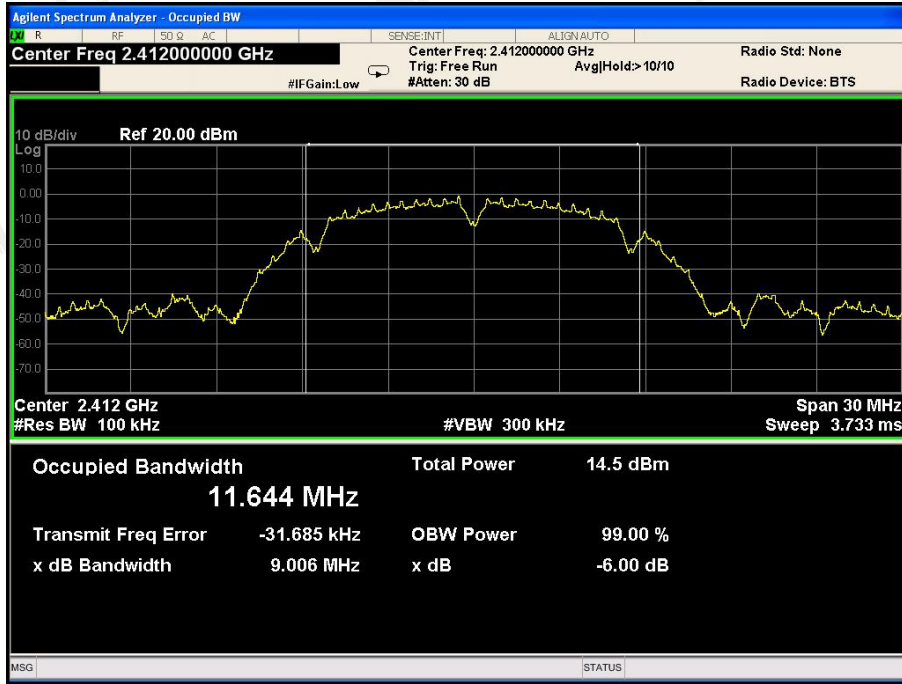

CH: 2437MHz

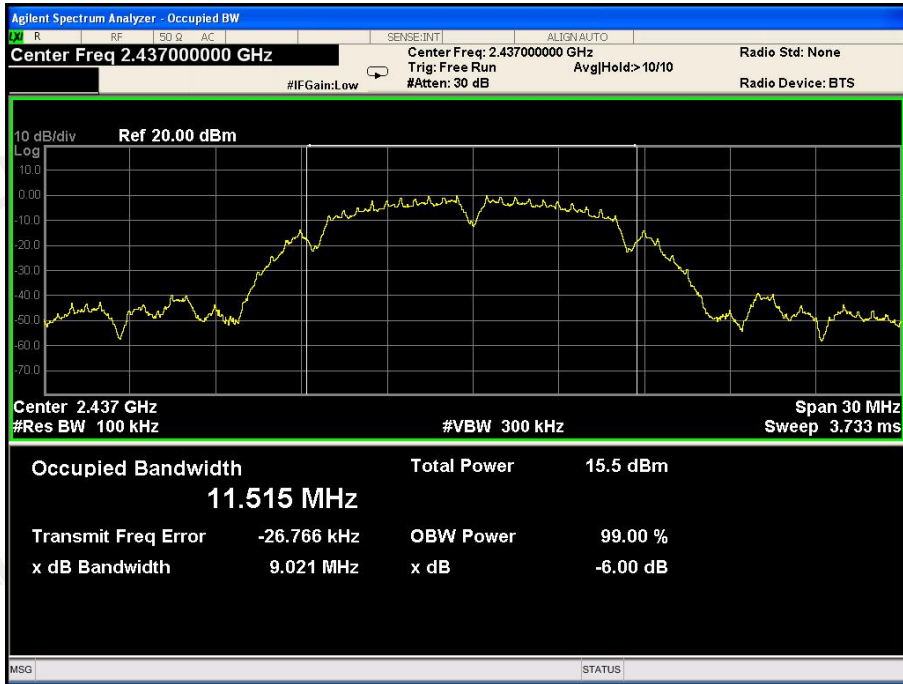

CH: 2462MHz

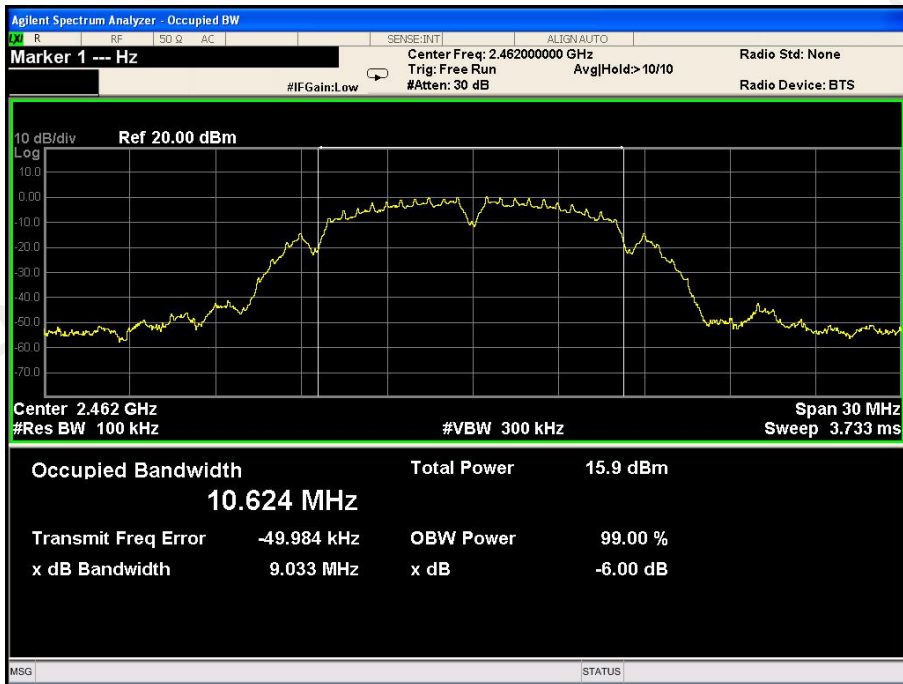



TX 802.11g Mode			
Frequency (MHz)	6dB Bandwidth (MHz)	Channel Separation (MHz)	Result
2412	16.30	>=500KHz	PASS
2437	16.29	>=500KHz	PASS
2462	16.29	>=500KHz	PASS

CH: 2412MHz

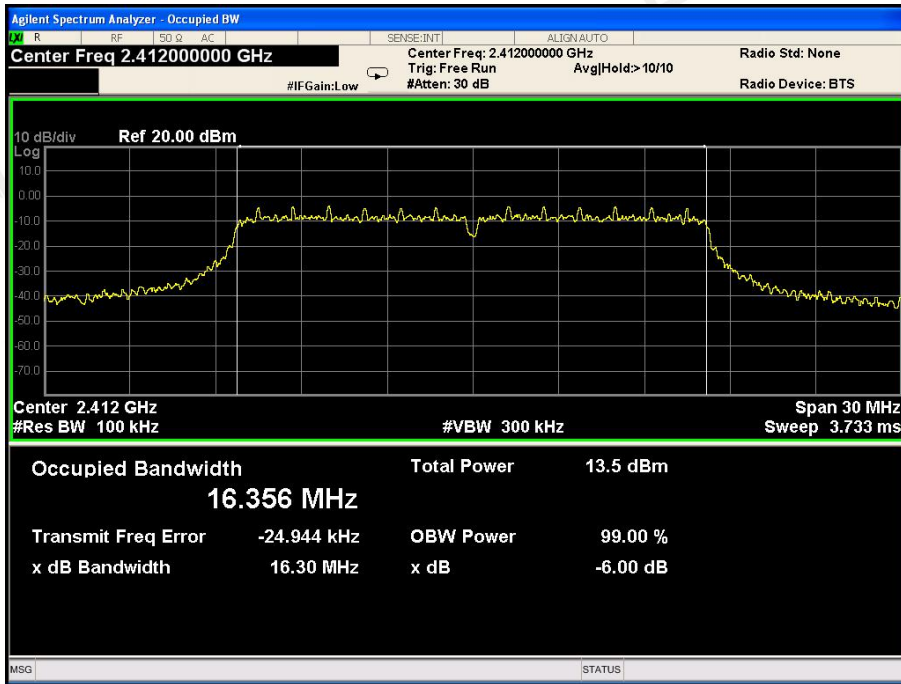

CH: 2437MHz

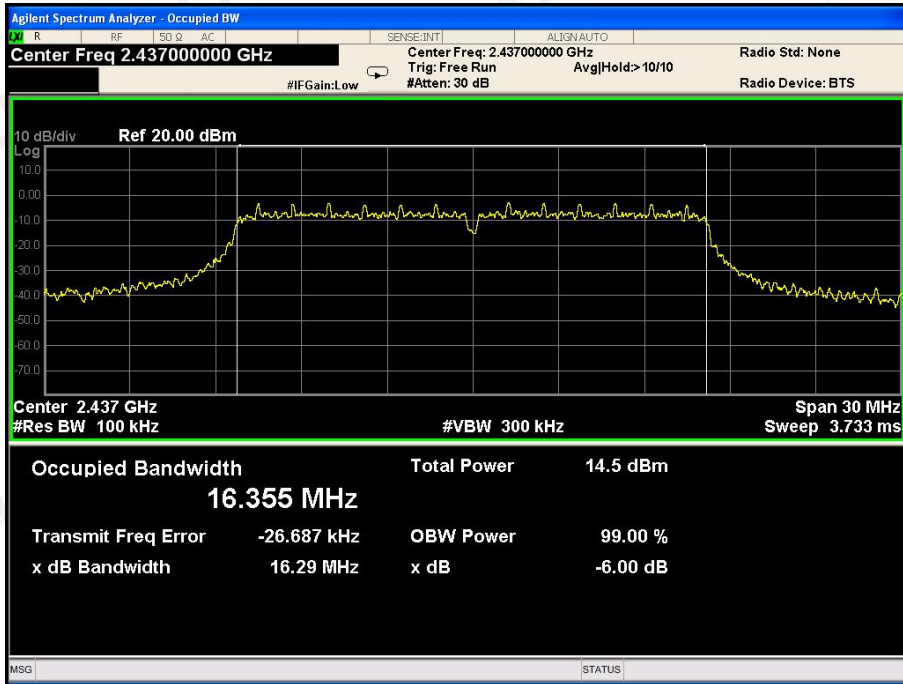

CH: 2462MHz

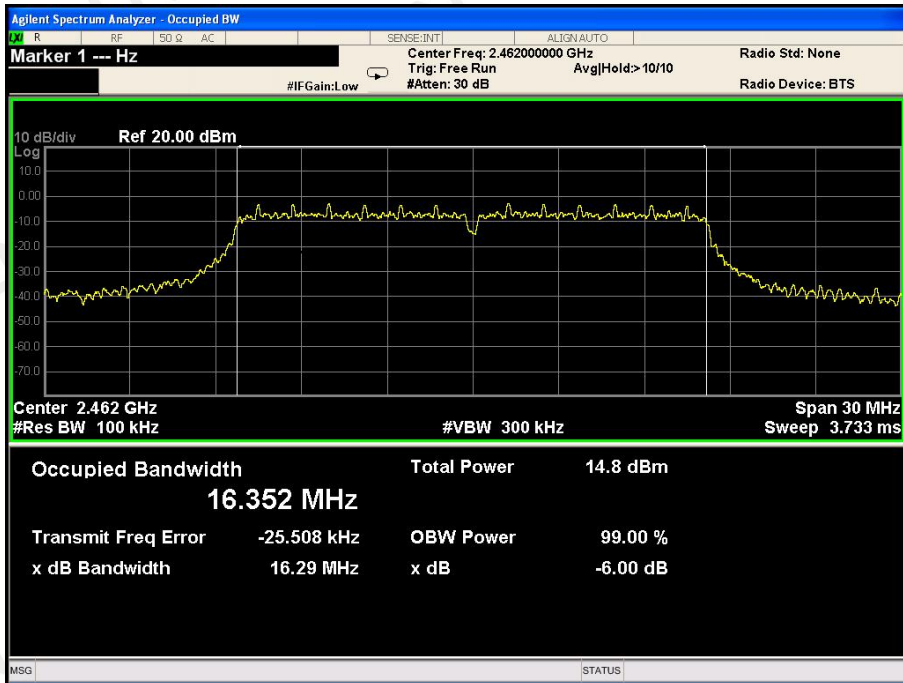

TX 802.11n/HT20 Mode			
Frequency (MHz)	6dB Bandwidth (MHz)	Channel Separation (MHz)	Result
2412	16.63	>=500KHz	PASS
2437	16.57	>=500KHz	PASS
2462	16.58	>=500KHz	PASS

CH: 2412MHz

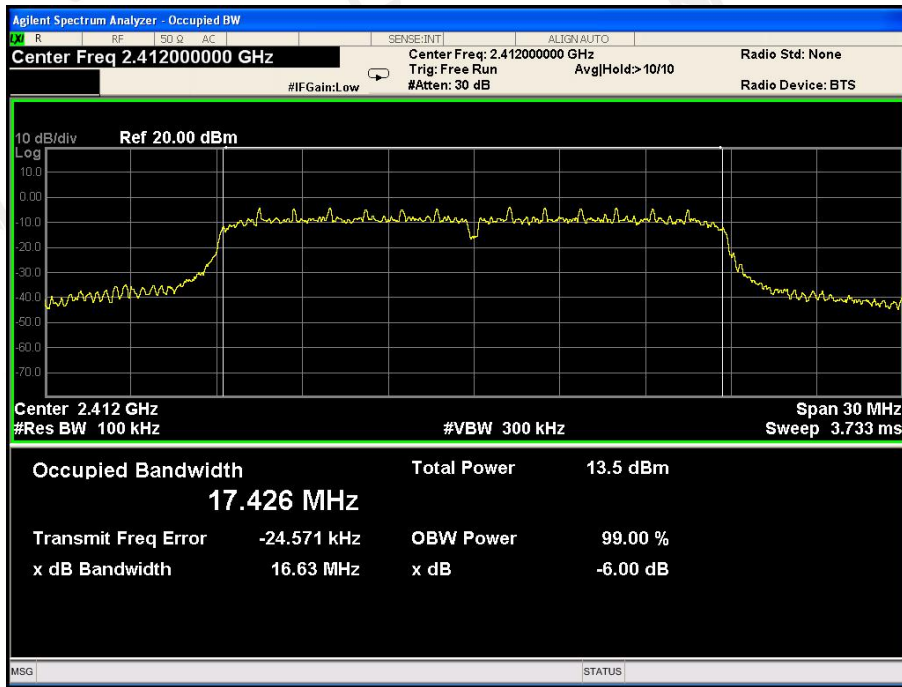

CH: 2437MHz

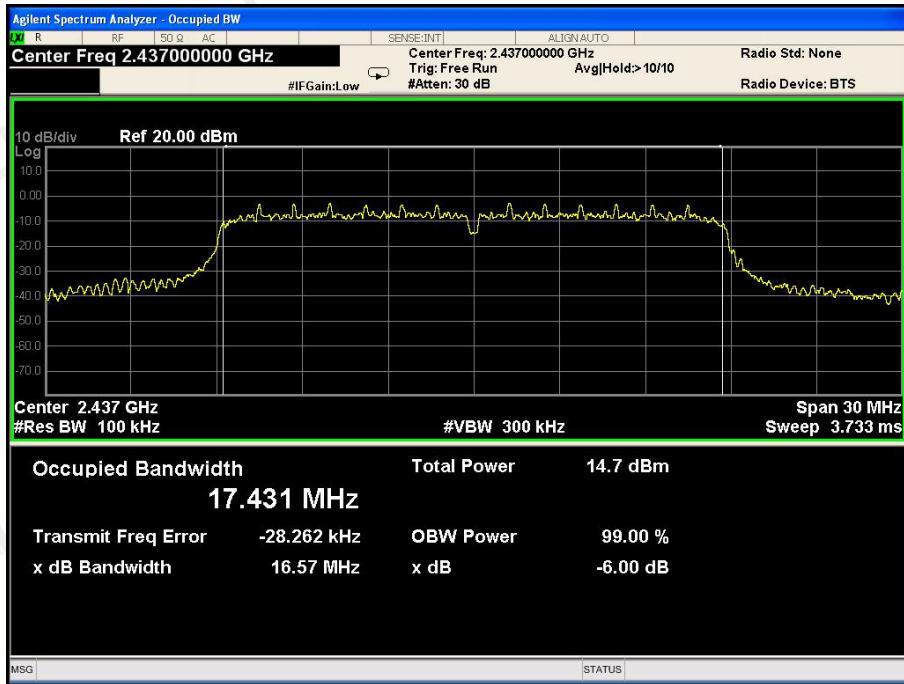

CH: 2462MHz

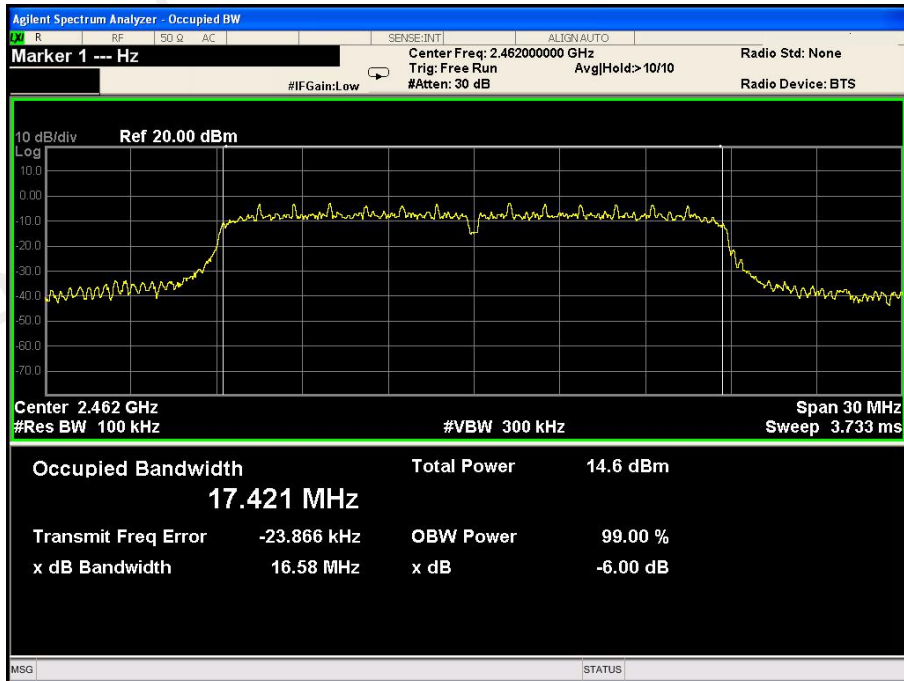

## 7 POWER SPECTRAL DENSITY TEST

### 7.1 Test Limit

FCC Part15(15.247), Subpart C				
Section	Test Item	Limit	Frequency Range (MHz)	Result
15.247	Power Spectral Density	8 dBm (in any 3KHz)	2400-2483.5	PASS

### 7.2 Test Procedure

1. The EUT was placed on a turn table which is 0.8m above ground plane.
2. Set EUT as normal operation.
3. Based on FCC Part15 C Section 15.247: RBW=3KHz, VBW=10KHz.
4. The useful radiated emission from the EUT was detected by the spectrum analyzer with peak detector.

### 7.3 Measurement Equipment Used

Same as Radiated Emission Measurement

### 7.4 Test Result

PASS



TX 802.11b Mode			
Frequency (MHz)	Power Density (dBm/3KHz)	Limit (dBm/3KHz)	Result
2412	-15.000	8	PASS
2437	-13.269	8	PASS
2462	-13.153	8	PASS

CH: 2412MHz

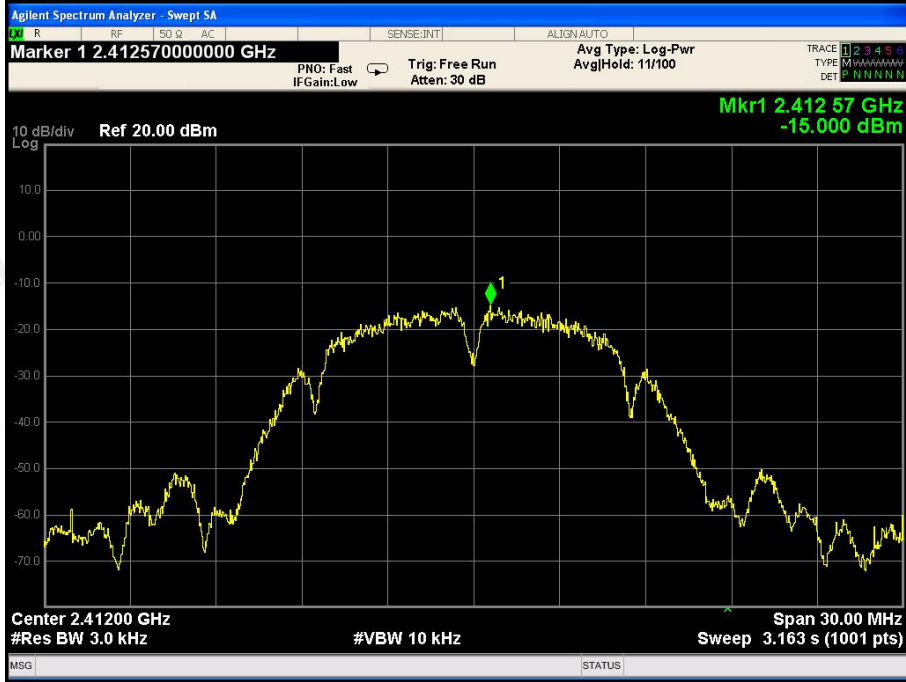

CH: 2437MHz

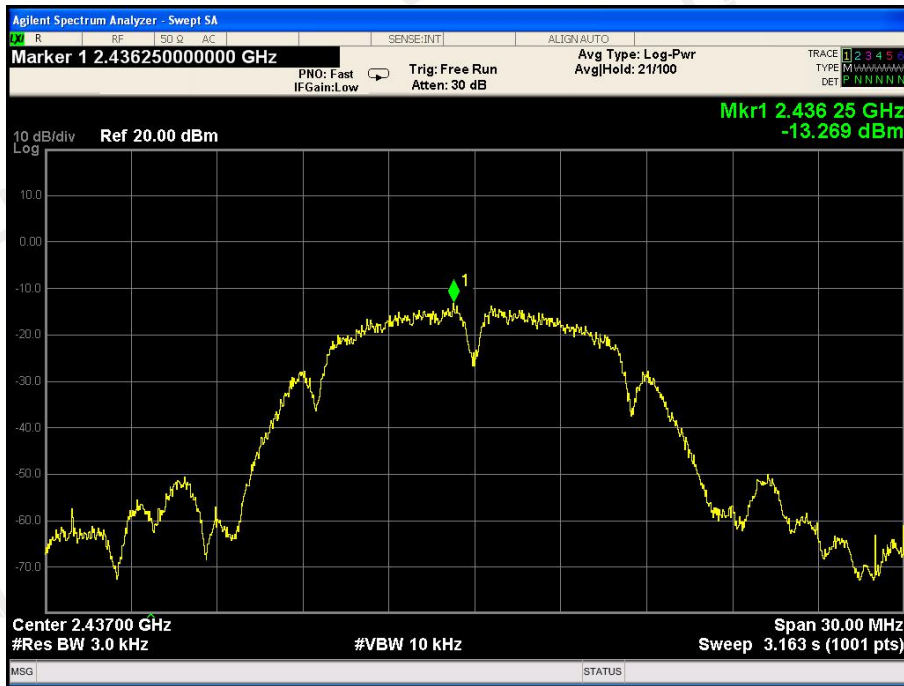

CH: 2462MHz

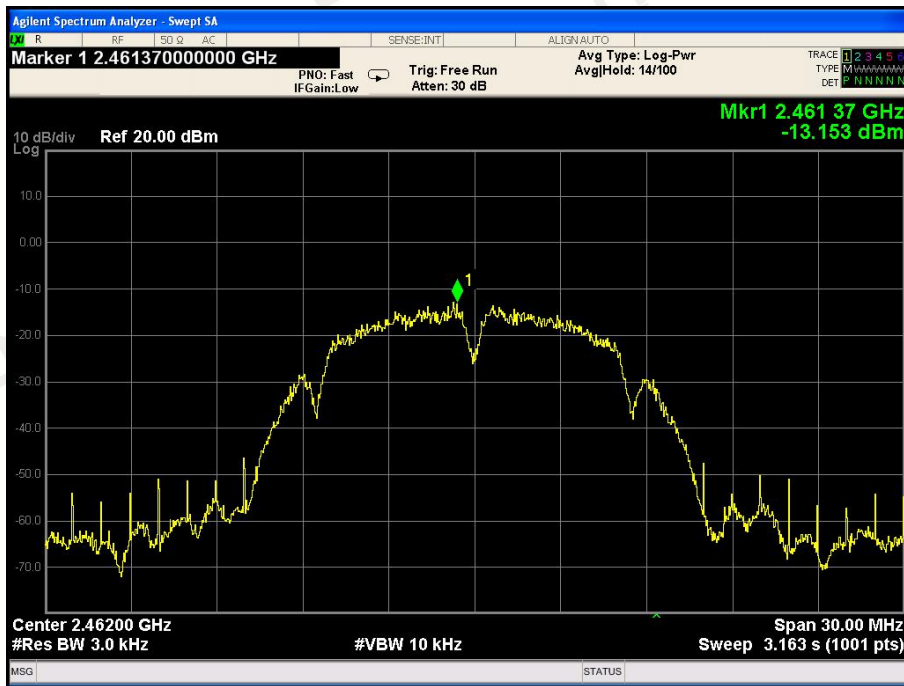

TX 802.11g Mode			
Frequency (MHz)	Power Density (dBm/3KHz)	Limit (dBm/3KHz)	Result
2412	-15.852	8	PASS
2437	-15.805	8	PASS
2462	-15.615	8	PASS

CH: 2412MHz

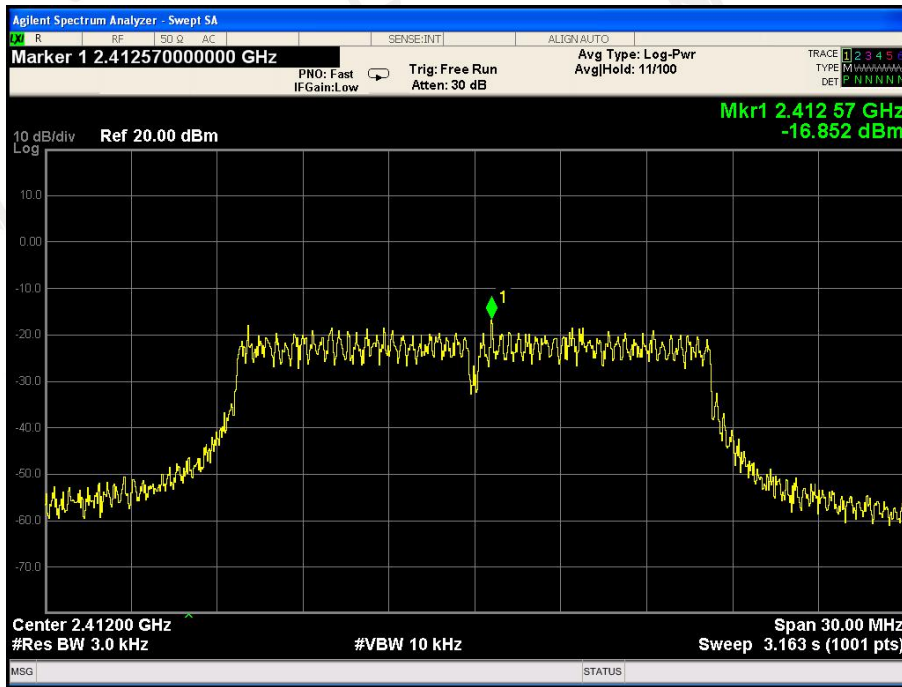

CH: 2437MHz

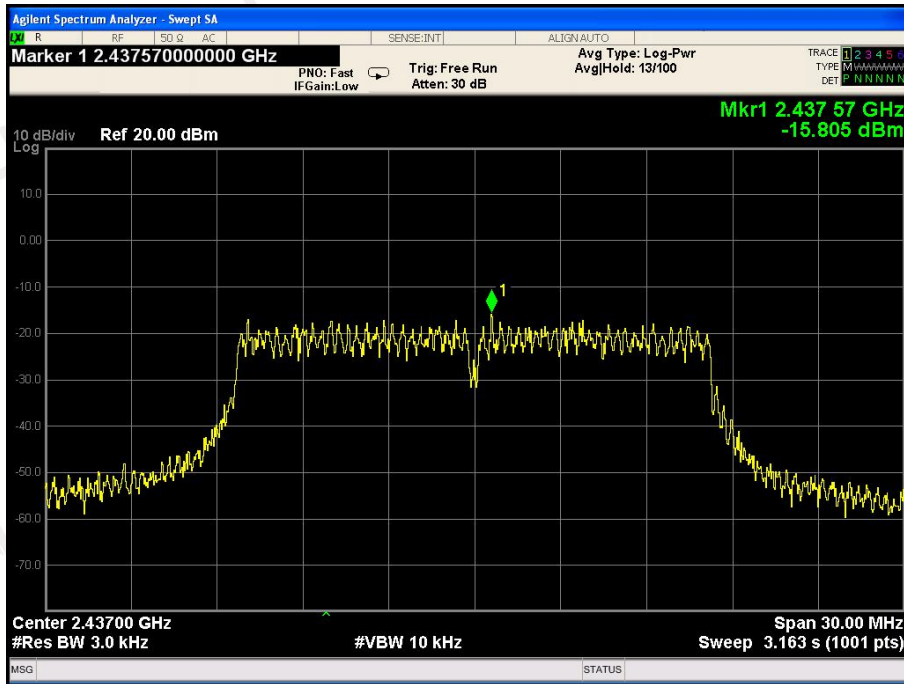

CH: 2462MHz

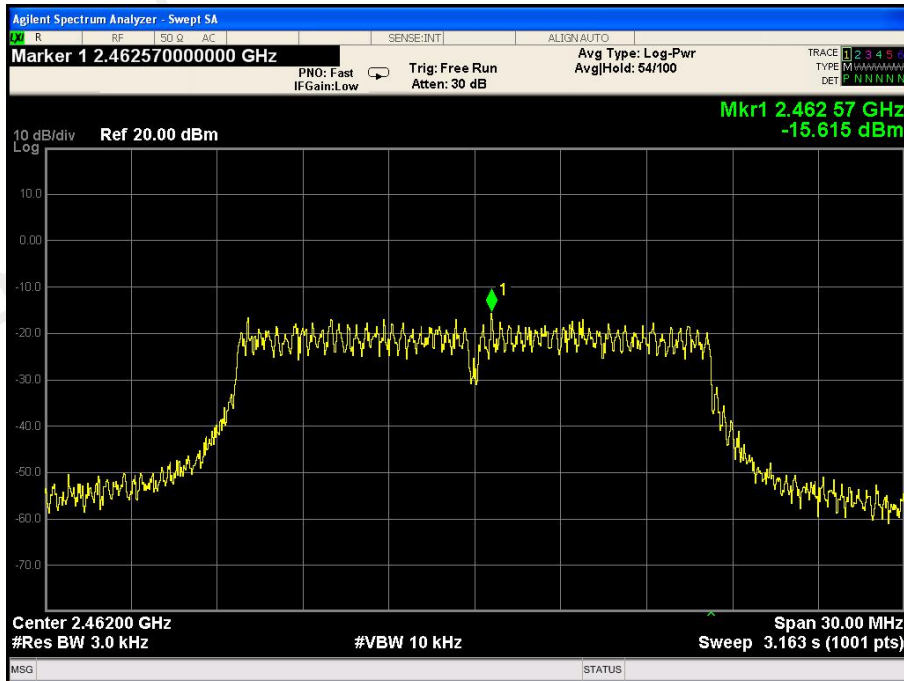

TX 802.11n/HT20 Mode			
Frequency (MHz)	Power Density (dBm/3KHz)	Limit (dBm/3KHz)	Result
2412	-17.068	8	PASS
2437	-16.051	8	PASS
2462	-15.959	8	PASS

CH: 2412MHz

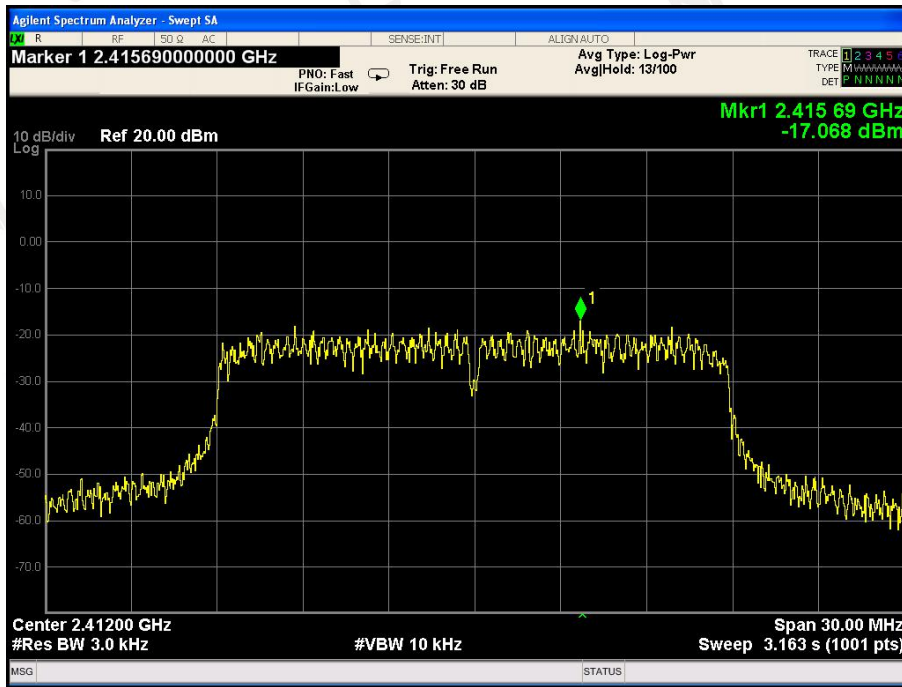



CH: 2437MHz

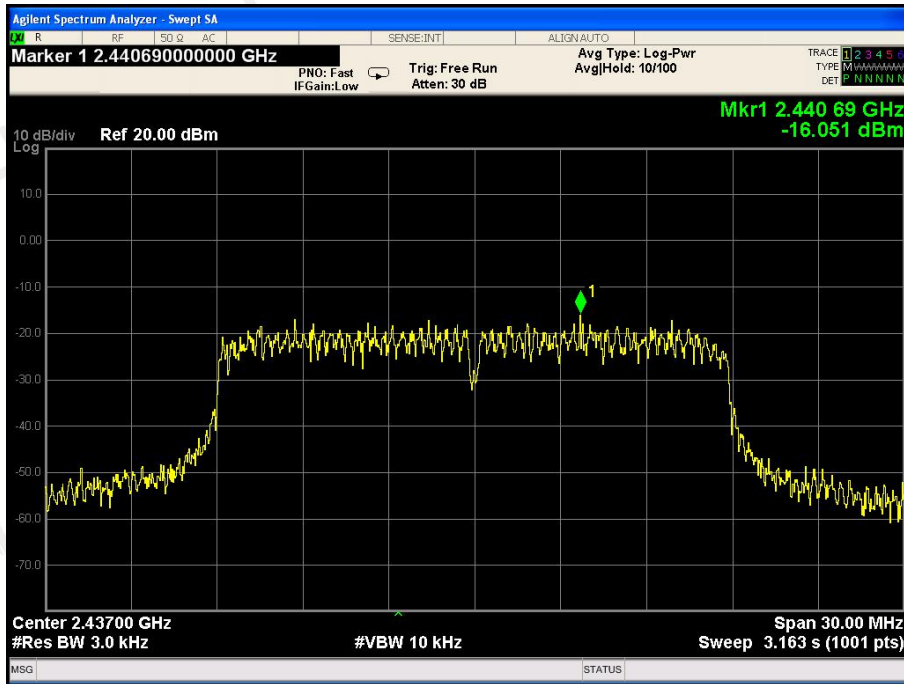

CH: 2462MHz

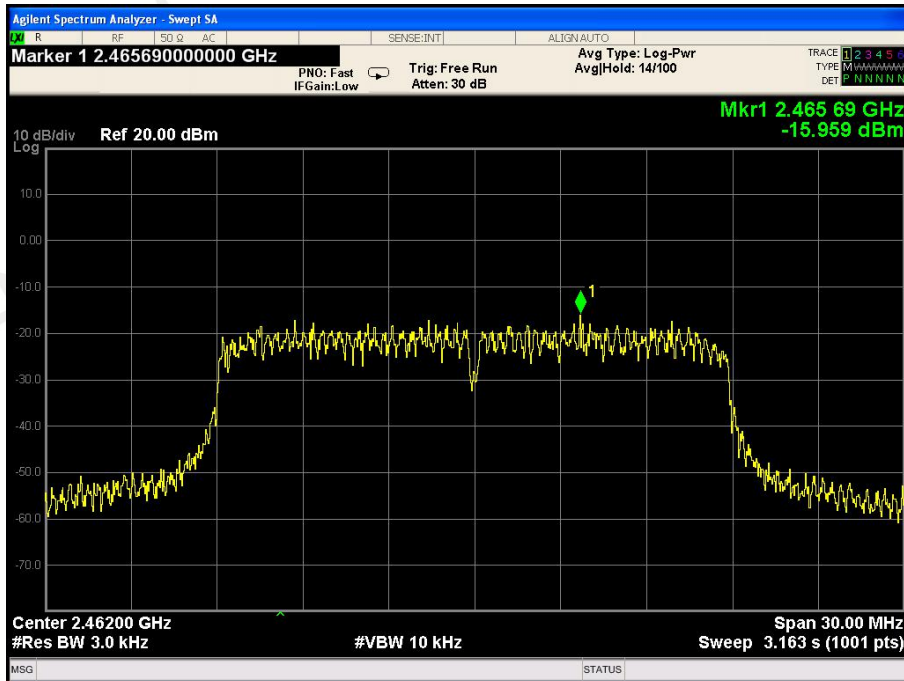

## 8 PEAK OUTPUT POWER TEST

### 8.1 Test Limit

FCC Part15(15.247), Subpart C				
Section	Test Item	Limit	Frequency Range (MHz)	Result
15.247(b)(3)	Peak Output Power	1 watt or 30dBm	2400-2483.5	PASS

### 8.2 Test Procedure

1. The EUT was placed on a turn table which is 0.8m above ground plane.
2. The EUT was directly connected to the Power meter.

### 8.3 Measurement Equipment Used

Same as Radiated Emission Measurement

### 8.4 Test Result

PASS

All the test modes completed for test.

TX 802.11b Mode			
Test Channel	Frequency (MHz)	Maximum Peak Conducted Output Power (dBm)	LIMIT (dBm)
CH01	2412	12.06	30
CH06	2437	12.12	30
CH11	2462	12.28	30
TX 802.11g Mode			
CH01	2412	11.09	30
CH06	2437	11.52	30
CH11	2462	11.34	30
TX 802.11n20 Mode			
CH01	2412	10.86	30
CH06	2437	11.06	30
CH11	2462	11.25	30

## 9 OUT OF BAND EMISSIONS TEST

### 9.1 Test Limit

In any 100 kHz bandwidth outside the frequency band in which the spread spectrum or digitally modulated intentional radiator is operating, the radio frequency power that is produced by the intentional radiator shall be at least 20 dB below that in the 100 kHz bandwidth within the band that contains the highest level of the desired power, based on either an RF conducted or a radiated measurement, provided the transmitter demonstrates compliance with the peak conducted power limits. If the transmitter complies with the conducted power limits based on the use of RMS averaging over a time interval, as permitted under paragraph (b)(3) of this section, the attenuation required under this paragraph shall be 30 dB instead of 20 dB.

### 9.2 Test Procedure

1. The EUT was placed on a turn table which is 0.8m above ground plane.
2. Set EUT as TX operation and connect directly to the spectrum analyzer.
3. Based on FCC Part15 C Section 15.247: RBW=100KHz, VBW=300KHz.
4. Set detected by the spectrum analyzer with peak detector.

### 9.3 Test Setup



### 9.4 Test Result

PASS

TX 802.11b Mode  
CH: 2412MHz

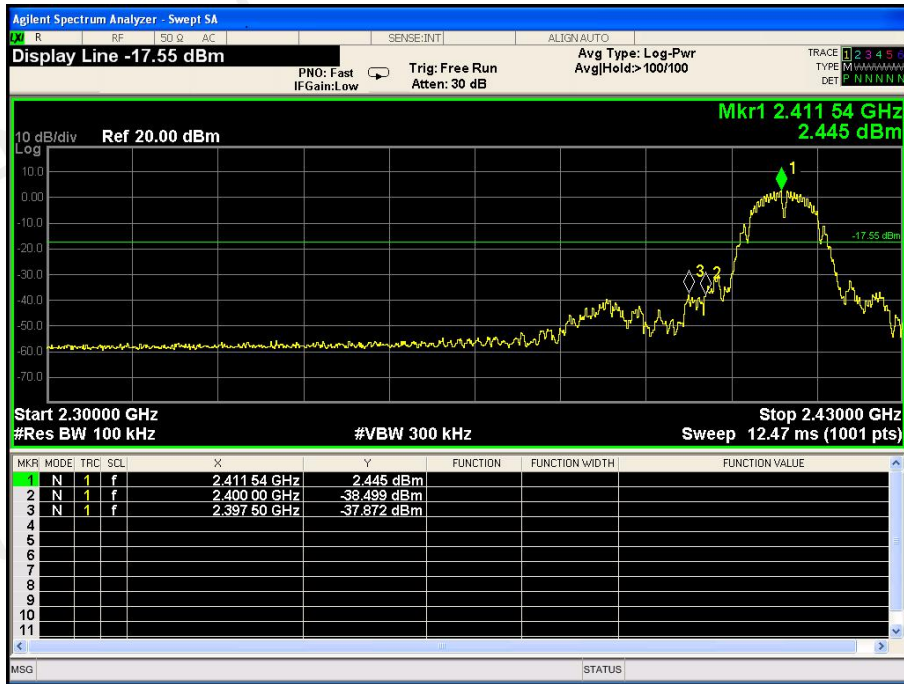

CH: 2462MHz



TX 802.11g Mode  
CH: 2412MHz

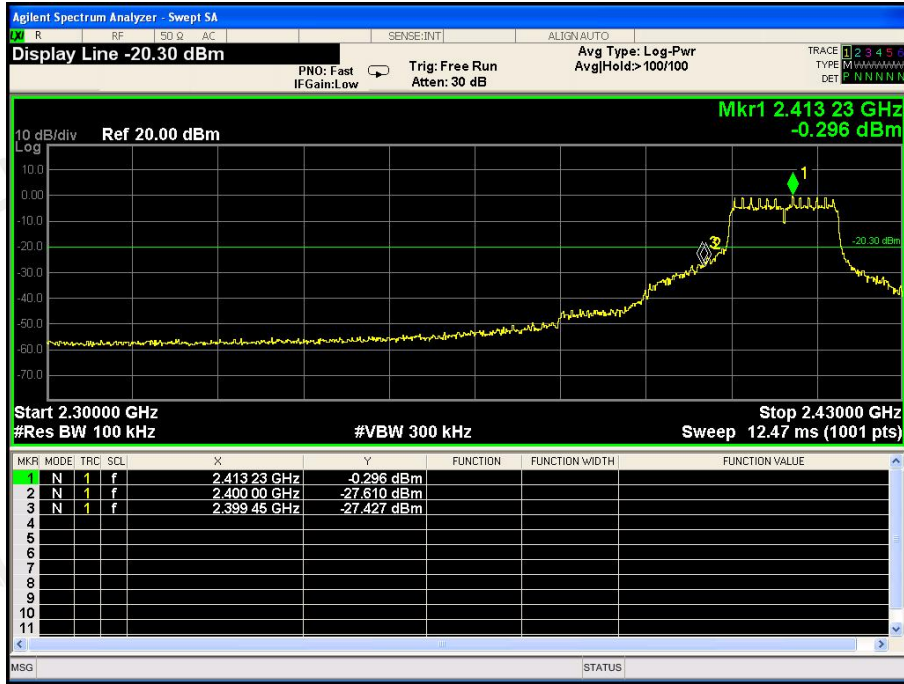

CH: 2462MHz

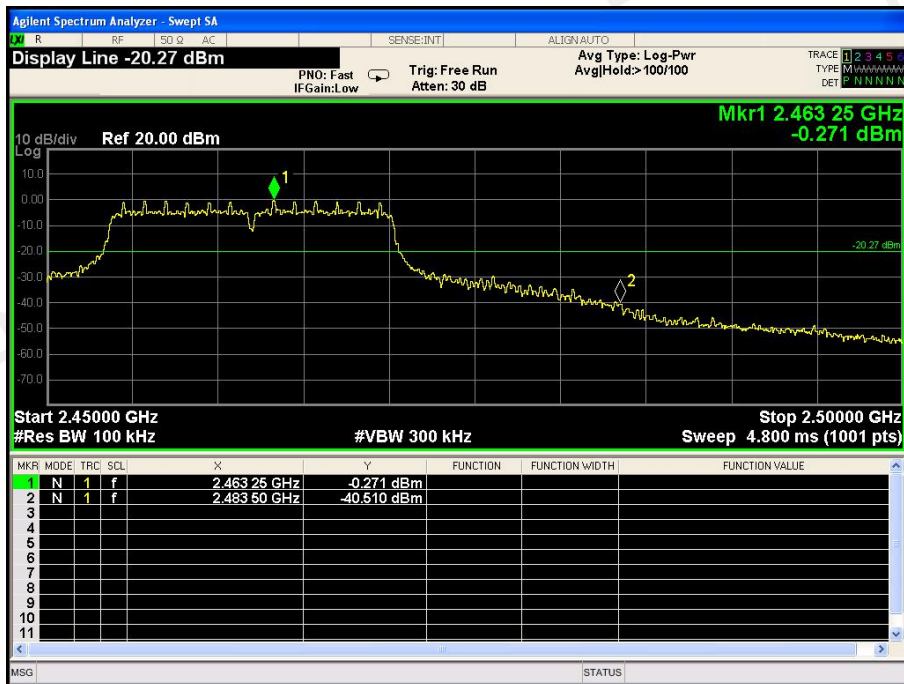



TX 802.11n/HT20 Mode  
CH: 2412MHz



CH: 2462MHz



## 10 ANTENNA REQUIREMENT

### Standard Applicable:

For intentional device, according to FCC 47 CFR Section 15.203, an intentional radiator shall be designed to ensure that no antenna other than that furnished by the responsible party shall be used with the device.

### Antenna Connected Construction

The antenna used is a detachable antenna, using a reverse Internet connector (Provided by non-manufacturers will use the product can not work), considered a special connector accepted by the FCC to comply with rule part 15.203. Please see EUT photos for details, it comply with the standard requirement. The directional gains of antenna used for transmitting is 1dBi.

### ANTENNA:

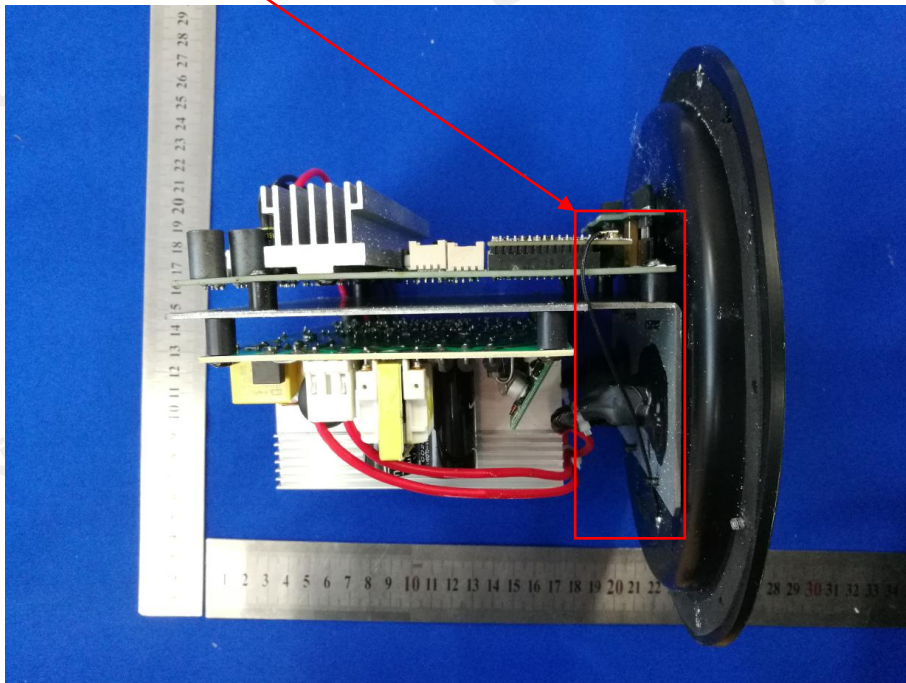

## 8 PHOTOGRAPH OF TEST

### 8.1 Radiated Emission



## 8.2 Conducted Emission

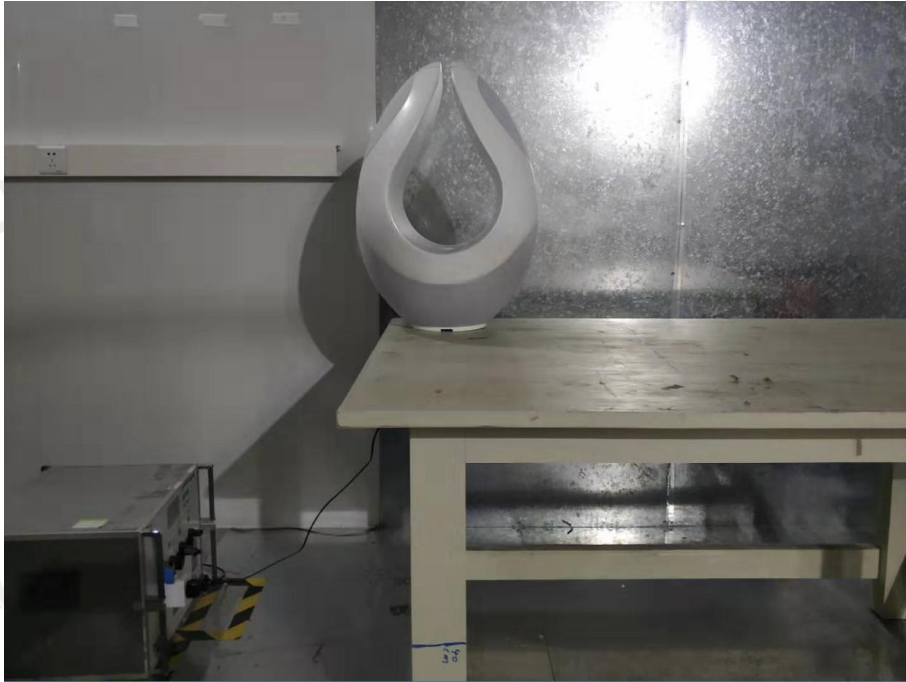

\*\*\*End of Report\*\*\*