

RADIO TEST REPORT

FCC 47 CFR PART 15 SUBPART C

Test Standard	FCC Part 15.247
Product name	SPX Sandpiper Digital Display
Brand Name	Connectpoint
Model No.	CP42
Test Result	Pass
Statements of Conformity	Determination of compliance is based on the results of the compliance measurement, not taking into account measurement instrumentation uncertainty.

The test Result was tested by Compliance Certification Services Inc. The test data, data evaluation, test procedures, and equipment configurations shown in this report were given in ANSI C63.10: 2013 and compliance standards.

The test results of this report relate only to the tested sample (EUT) identified in this report.

The test Report of full or partial shall not copy. Without written approval of Compliance Certification Services Inc. (Wugu Laboratory).

Approved by:



Kevin Tsai
Deputy Manager

Unless otherwise stated the results shown in this test report refer only to the sample(s) tested and such sample(s) are retained for 90 days only.
除非另有說明，此報告結果僅對測試之樣品負責，同時此樣品僅保留90天。本報告未經本公司書面許可，不可部份複製。

This document is issued by the Company subject to its General Conditions of Service printed overleaf, available on request or accessible at <http://www.sgs.com.tw/Terms-and-Conditions> and, for electronic format documents, subject to Terms and Conditions for Electronic Documents at <http://www.sgs.com.tw/Terms-and-Conditions>. Attention is drawn to the limitation of liability, indemnification and jurisdiction issues defined therein. Any holder of this document is advised that information contained hereon reflects the Company's findings at the time of its intervention only and within the limits of client's instruction, if any. The Company's sole responsibility is to its Client and this document does not exonerate parties to a transaction from exercising all their rights and obligations under the transaction documents. This document cannot be reproduced, except in full, without prior written approval of the Company. Any unauthorized alteration, forgery or falsification of the content or appearance of this document is unlawful and offenders may be prosecuted to the fullest extent of the law.

Revision History

Rev.	Issue Date	Revisions	Effect Page	Revised By
00	June 18, 2021	Initial Issue	ALL	Allison Chen

Table of contents

1.	GENERAL INFORMATION.....	4
1.1	EUT INFORMATION.....	4
1.2	EUT CHANNEL INFORMATION.....	5
1.3	ANTENNA INFORMATION.....	5
1.4	MEASUREMENT UNCERTAINTY.....	6
1.5	FACILITIES AND TEST LOCATION.....	7
1.6	INSTRUMENT CALIBRATION.....	7
1.7	SUPPORT AND EUT ACCESSORIES EQUIPMENT.....	8
1.8	TEST METHODOLOGY AND APPLIED STANDARDS.....	8
2.	TEST SUMMARY.....	9
3.	DESCRIPTION OF TEST MODES.....	10
3.1	THE WORST MODE OF OPERATING CONDITION.....	10
3.2	THE WORST MODE OF MEASUREMENT.....	11
3.3	EUT DUTY CYCLE.....	12
4.	TEST RESULT.....	13
4.1	AC POWER LINE CONDUCTED EMISSION.....	13
4.2	6DB BANDWIDTH AND OCCUPIED BANDWIDTH (99%).....	16
4.3	OUTPUT POWER MEASUREMENT.....	26
4.4	POWER SPECTRAL DENSITY.....	29
4.5	CONDUCTED BANDEDGE AND SPURIOUS EMISSION.....	35
4.6	RADIATION BANDEDGE AND SPURIOUS EMISSION.....	48
	APPENDIX 1 - PHOTOGRAPHS OF EUT.....	A-1

Report No.: T210324W02-RP1

1. GENERAL INFORMATION

1.1 EUT INFORMATION

Applicant	Connectpoint Inc. 175 Cremona, Suite 160 Goleta California 93117 United States
Manufacturer	Connectpoint Inc. 175 Cremona, Suite 160 Goleta California 93117 United States
Equipment	SPX Sandpiper Digital Display
Model Name	CP42
Model Discrepancy	N/A
Trade Name	Connectpoint
Received Date	March 24, 2021
Date of Test	May 6 ~ 7, 2021
Power Supply	Power from Adapter. CHANNEL WELL TECHNOLOGY / KPL-050F-VI I/P: 100-240VAC, 50/60Hz, 1.7A O/P: 12VDC, 4.17A 50W

Remark:

1. For more details, refer to the User's manual of the EUT.
2. Disclaimer: Antenna information is provided by the applicant, test results of this report are applicable to the sample EUT received.

Report No.: T210324W02-RP1

1.2 EUT CHANNEL INFORMATION

Frequency Range	802.11b/g/n HT 20: 2412MHz ~ 2462MHz 802.11n HT40: 2422MHz ~ 2452MHz
Modulation Type	1. IEEE 802.11b mode: CCK 2. IEEE 802.11g mode: OFDM 3. IEEE 802.11n HT 20 MHz mode : OFDM 4. IEEE 802.11n HT40 Mode: OFDM
Number of channel	1. IEEE 802.11b mode: 11 Channels 2. IEEE 802.11g mode: 11 Channels 3. IEEE 802.11n HT 20 MHz mode : 11 Channels 4. IEEE 802.11n HT40 Mode : 7 Channels

Remark:

Refer as ANSI C63.10: 2013 clause 5.6.1 Table 4 for test channels

Number of frequencies to be tested		
Frequency range in which device operates	Number of frequencies	Location in frequency range of operation
<input type="checkbox"/> 1 MHz or less	1	Middle
<input type="checkbox"/> 1 MHz to 10 MHz	2	1 near top and 1 near bottom
<input checked="" type="checkbox"/> More than 10 MHz	3	1 near top, 1 near middle, and 1 near bottom

1.3 ANTENNA INFORMATION

Antenna Specification	<input type="checkbox"/> PIFA <input checked="" type="checkbox"/> PCB <input type="checkbox"/> Dipole <input type="checkbox"/> Coils
Antenna Gain	Gain: 4 dBi
Antenna connector	I-PEX

1.4 MEASUREMENT UNCERTAINTY

PARAMETER	UNCERTAINTY
AC Powerline Conducted Emission	+/- 1.2575
Emission bandwidth, 20dB bandwidth	+/- 0.0014
RF output power, conducted	+/- 1.14
Power density, conducted	+/- 1.40
3M Semi Anechoic Chamber / 30M~200M	+/- 4.12
3M Semi Anechoic Chamber / 200M~1000M	+/- 4.68
3M Semi Anechoic Chamber / 1G~8G	+/- 5.18
3M Semi Anechoic Chamber / 8G~18G	+/- 5.47
3M Semi Anechoic Chamber / 18G~26G	+/- 3.81
3M Semi Anechoic Chamber / 26G~40G	+/- 3.87

Remark:

- 1.This uncertainty represents an expanded uncertainty expressed at approximately the 95% confidence level using a coverage factor of k=2
2. ISO/IEC 17025 requires that an estimate of the measurement uncertainties associated with the emissions test results be included in the report.

Report No.: T210324W02-RP1

1.5 FACILITIES AND TEST LOCATION

All measurement facilities used to collect the measurement data are located at No.11, Wugong 6th Rd., Wugu Dist., New Taipei City, Taiwan. (R.O.C.)

Test site	Test Engineer	Remark
AC Conduction Room	Jerry Chang	-
Radiation	Ray Li	-
RF Conducted	Jack Chen	-

Remark: The sites are constructed in conformance with the requirements of ANSI C63.7, ANSI C63.4 and CISPR Publication 22.

1.6 INSTRUMENT CALIBRATION

RF Conducted Test Site					
Name of Equipment	Manufacturer	Model	Serial Number	Calibration Date	Calibration Due
Coaxial Cable	Woken	WC12	CC003	06/29/2020	06/28/2021
Signal Analyzer	R&S	FSV 40	101073	09/17/2020	09/16/2021
Power Meter	Anritsu	ML2487A	6K00003260	05/21/2020	05/20/2021
Power Seneor	Anritsu	MA2490A	032910	05/21/2020	05/20/2021
Software	N/A				

AC Power Line Conducted Emission Test Room					
Name of Equipment	Manufacturer	Model	Serial Number	Calibration Date	Calibration Due
CABLE	EMCI	CFD300-NL	CERF	06/29/2020	06/28/2021
EMI Test Receiver	R&S	ESCI	100064	07/17/2020	07/16/2021
LISN	SCHAFFNER	NNB 41	03/10013	02/02/2021	02/01/2022
Software	EZ-EMC(CCS-3A1-CE-wugu)				

Remark: Each piece of equipment is scheduled for calibration once a year.

3M 966 Chamber Test Site					
Equipment	Manufacturer	Model	S/N	Cal Date	Cal Due
Band Reject Filters	MICRO TRONICS	BRM 50702	120	02/08/2021	02/07/2022
Bilog Antenna	Sunol Sciences	JB3	A030105	07/24/2020	07/23/2021
Horn Antenna	ETS LINDGREN	3116	00026370	12/11/2020	12/10/2021
Coaxial Cable	HUBER SUHNER	SUCOFLEX 104PEA	20995	02/24/2021	02/23/2022
Coaxial Cable	EMCI	EMC105	190914+327109/4	09/19/2020	09/18/2021
K Type Cable	Huber+Suhner	SUCOFLEX 102	29406/2	12/09/2020	12/08/2021
K Type Cable	Huber+Suhner	SUCOFLEX 102	22470/2	12/09/2020	12/08/2021
Digital Thermo-Hygro Meter	WISEWIND	1206	D07	01/06/2021	01/05/2022
double Ridged Guide Horn Antenna	ETC	MCTD 1209	DRH13M02003	09/30/2020	09/29/2021
Loop Ant	COM-POWER	AL-130	121051	04/07/2021	04/06/2022
Pre-Amplifier	EMEC	EM330	060609	02/24/2021	02/23/2022
Pre-Amplifier	HP	8449B	3008A00965	12/25/2020	12/24/2021
Pre-Amplifier	MITEQ	AMF-6F-18004000-37-8P	985646	09/02/2020	09/01/2021
PSA Series Spectrum Analyzer	Agilent	E4446A	MY46180323	07/24/2020	07/23/2021
Antenna Tower	CCS	CC-A-1F	N/A	N.C.R	N.C.R
Controller	CCS	CC-C-1F	N/A	N.C.R	N.C.R
Turn Table	CCS	CC-T-1F	N/A	N.C.R	N.C.R
Software	e3 6.11-20180419c				

Remark: Each piece of equipment is scheduled for calibration once a year.

1.7 SUPPORT AND EUT ACCESSORIES EQUIPMENT

Support Equipment					
No.	Equipment	Brand	Model	Series No.	FCC ID
1	NB(J)	TOSHIBA	PT345T-00L002	N/A	PD97260H

Support Equipment					
No.	Equipment	Brand	Model	Series No.	FCC ID
	N/A				

1.8 TEST METHODOLOGY AND APPLIED STANDARDS

The test methodology, setups and results comply with all requirements in accordance with ANSI C63.10:2013, FCC Part 2, FCC Part 15.247.

2. TEST SUMMARY

FCC Standard Section	Report Section	Test Item	Result
15.203	1.3	Antenna Requirement	Pass
15.207(a)	4.1	AC Conducted Emission	Pass
15.247(a)(2)	4.2	6 dB Bandwidth	Pass
-	4.2	Occupied Bandwidth (99%)	Pass
15.247(b)	4.3	Output Power Measurement	Pass
15.247(e)	4.4	Power Spectral Density	Pass
15.247(d)	4.5	Conducted Band Edge	Pass
15.247(d)	4.5	Conducted Spurious Emission	Pass
15.247(d)	4.6	Radiation Band Edge	Pass
15.247(d)	4.6	Radiation Spurious Emission	Pass

3. DESCRIPTION OF TEST MODES

3.1 THE WORST MODE OF OPERATING CONDITION

<p>Operation mode</p>	<p>IEEE 802.11b mode :1Mbps IEEE 802.11g mode :6Mbps IEEE 802.11n HT20 mode :MCS0 IEEE 802.11n HT40 mode :MCS0</p>
<p>Test Channel Frequencies</p>	<p>IEEE 802.11b mode : 1. Lowest Channel : 2412MHz 2. Middle Channel : 2437MHz 3. Highest Channel : 2462MHz IEEE 802.11g mode : 1. Lowest Channel : 2412MHz 2. Middle Channel : 2437MHz 3. Highest Channel : 2462MHz IEEE 802.11n HT20 mode : 1. Lowest Channel : 2412MHz 2. Middle Channel : 2437MHz 3. Highest Channel : 2462MHz IEEE 802.11n HT40 Mode : 1. Lowest Channel : 2422MHz 2. Middle Channel : 2437MHz 3. Highest Channel : 2452MHz</p>
<p>Operation Transmitter</p>	<p>IEEE 802.11b mode : 1T1R IEEE 802.11g mode : 1T1R IEEE 802.11n HT20 mode : 1T1R IEEE 802.11n HT40 mode : 1T1R</p>

Remark:

1. EUT pre-scanned data rate of output power for each mode, the worst data rate were recorded in this report.

Report No.: T210324W02-RP1

3.2 THE WORST MODE OF MEASUREMENT

AC Power Line Conducted Emission	
Test Condition	AC Power line conducted emission for line and neutral
Power supply Mode	Mode 1: EUT power by Adapter
Worst Mode	<input checked="" type="checkbox"/> Mode 1 <input type="checkbox"/> Mode 2 <input type="checkbox"/> Mode 3 <input type="checkbox"/> Mode 4

Radiated Emission Measurement Below 1G	
Test Condition	Radiated Emission Below 1G
Power supply Mode	Mode 1: EUT power by Adapter
Worst Mode	<input checked="" type="checkbox"/> Mode 1 <input type="checkbox"/> Mode 2 <input type="checkbox"/> Mode 3 <input type="checkbox"/> Mode 4

Radiated Emission Measurement Above 1G	
Test Condition	Radiated Emission Above 1G
Power supply Mode	Mode 1: EUT power by Adapter
Worst Mode	<input checked="" type="checkbox"/> Mode 1 <input type="checkbox"/> Mode 2 <input type="checkbox"/> Mode 3 <input type="checkbox"/> Mode 4
Worst Position	<input type="checkbox"/> Placed in fixed position. <input checked="" type="checkbox"/> Placed in fixed position at X-Plane (E2-Plane) <input type="checkbox"/> Placed in fixed position at Y-Plane (E1-Plane) <input type="checkbox"/> Placed in fixed position at Z-Plane (H-Plane)

Remark:

1. The worst mode was record in this test report.
2. EUT pre-scanned in three axis ,X,Y, Z and two polarity, for radiated measurement. The worst case(X-Plane) were recorded in this report
3. AC power line conducted emission and for below 1G radiation emission were performed the EUT transmit at the highest output power channel as worse case.

Report No.: T210324W02-RP1

3.3 EUT DUTY CYCLE

Temperature: 23.9°C

Test date:

May 6, 2021

Humidity: 51% RH

Tested by:

Jack Chen

Duty Cycle				
Configuration	Duty Cycle (%)	Duty Factor (dB) =10*log (1/Duty Cycle)	1/T (kHz)	VBW setting (kHz)
802.11b	100%	0.00	N/A	0.01
802.11g	100%	0.00	N/A	0.01
802.11n HT20	100%	0.00	N/A	0.01
802.11n HT40	100%	0.00	N/A	0.01

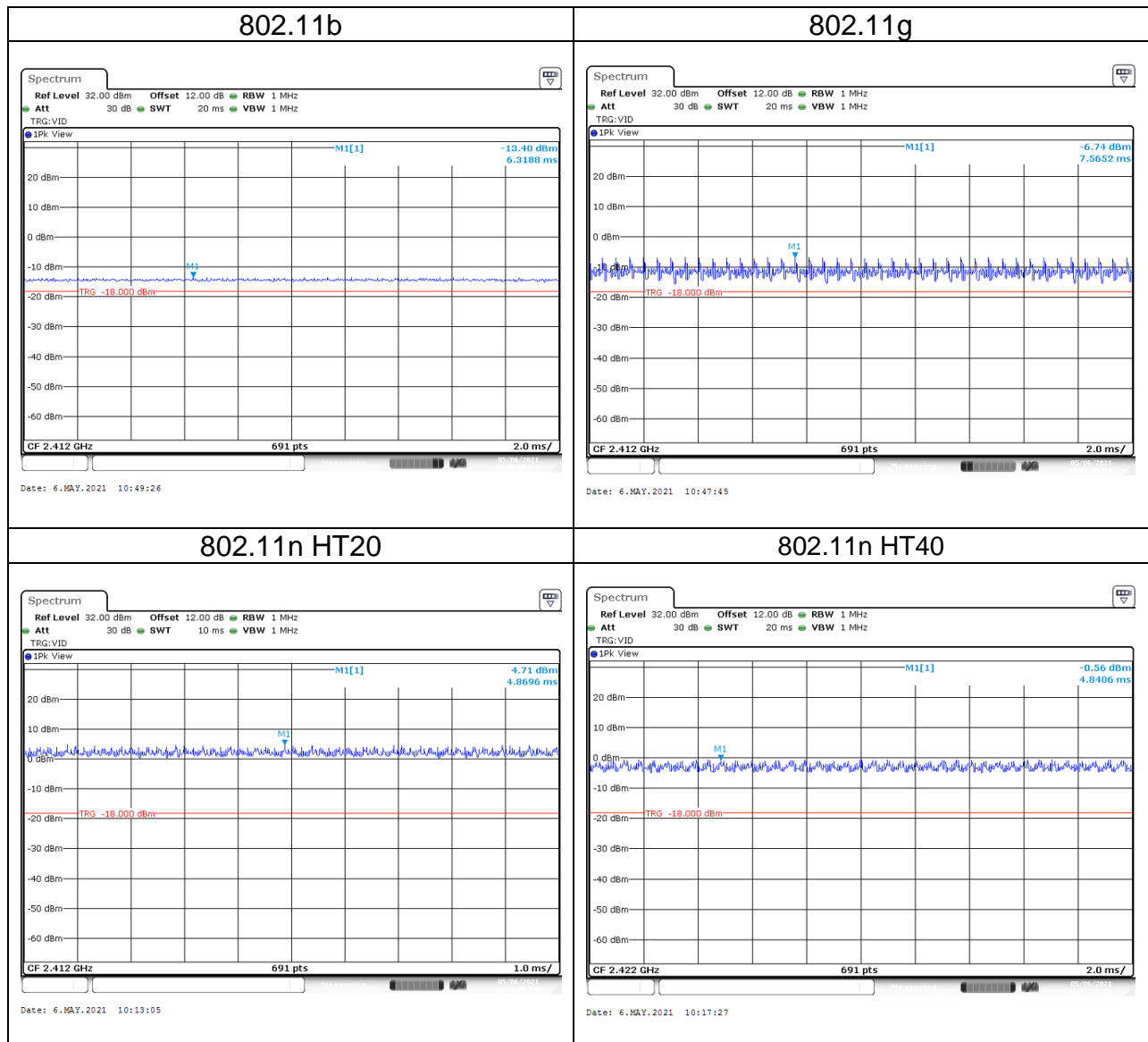

Report No.: T210324W02-RP1

4. TEST RESULT

4.1 AC POWER LINE CONDUCTED EMISSION

4.1.1 Test Limit

According to §15.207(a)(2),

Frequency Range (MHz)	Limits(dBµV)	
	Quasi-peak	Average
0.15 to 0.50	66 to 56*	56 to 46*
0.50 to 5	56	46
5 to 30	60	50

* Decreases with the logarithm of the frequency.

4.1.2 Test Procedure

Test method Refer as ANSI C63.10: 2013,

1. The EUT was placed on a non-conducted table, which is 0.8m above horizontal ground plane and 0.4m above vertical ground plane.
2. EUT connected to the line impedance stabilization network (LISN)
3. Receiver set RBW of 9kHz and Detector Peak, and note as quasi-peak and average.
4. Maximum procedure was performed on the six highest emissions to ensure EUT compliance.
5. Recorded Line for Neutral and Line.

4.1.3 Test Setup

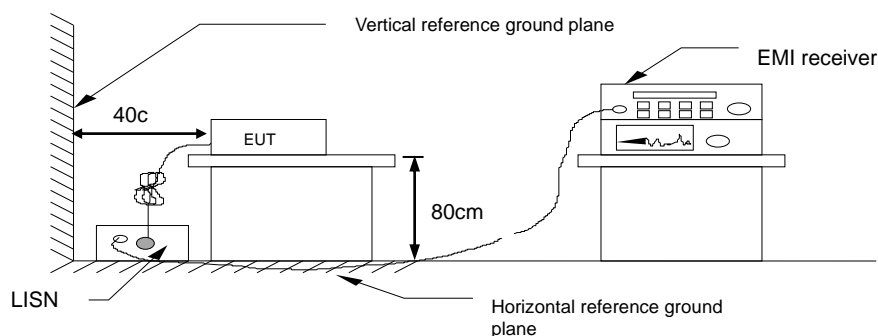

4.1.4 Test Result

Pass.

Test Data

Test Mode:	Mode 1	Temp/Hum	24.3(°C)/ 55%RH
Phase:	Line	Test Date	May 7, 2021
Test Voltage:	120Vac, 60Hz	Test Engineer	Jerry Chang

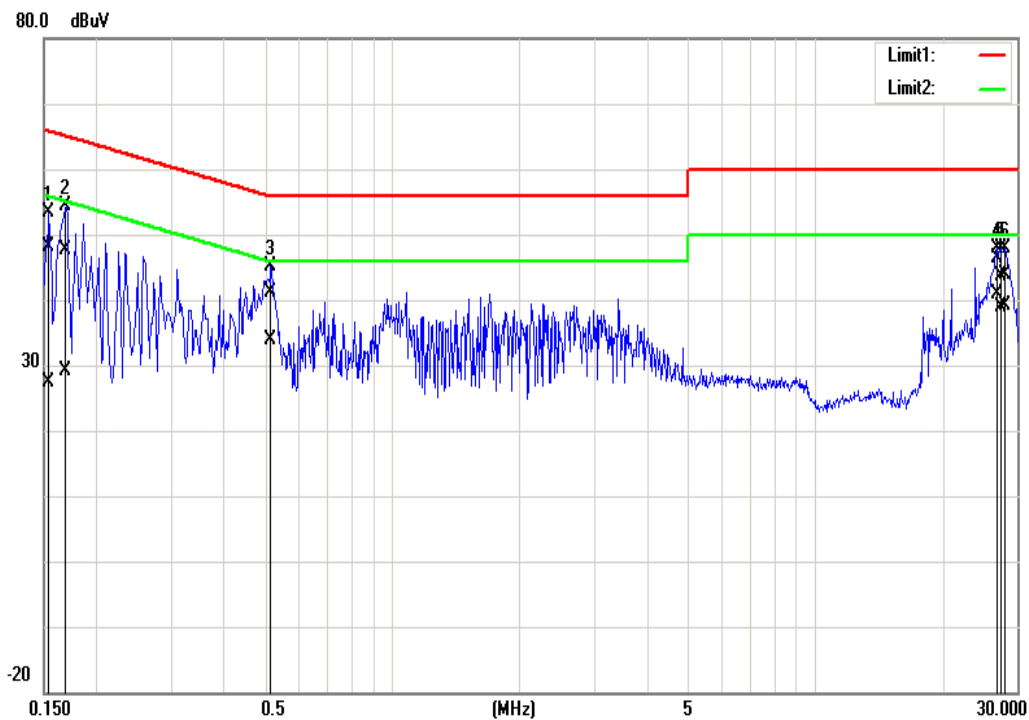

Frequency (MHz)	Quasi Peak reading (dBuV)	Average reading (d uV)	Correction factor (dB)	Quasi Peak result (dBuV)	Average result (dBuV)	Quasi Peak limit (dBuV)	Average limit (dBuV)	Quasi Peak margin (dB)	Average margin (dB)	Remark
0.1540	37.80	17.11	10.29	48.09	27.40	65.78	55.78	-17.69	-28.38	Pass
0.1700	37.39	18.79	10.29	47.68	29.08	64.96	54.96	-17.28	-25.88	Pass
0.5180	30.86	23.51	10.29	41.15	33.80	56.00	46.00	-14.85	-12.20	Pass
26.9380	36.13	30.62	10.24	46.37	40.86	60.00	50.00	-13.63	-9.14	Pass
27.4860	33.40	28.53	10.23	43.63	38.76	60.00	50.00	-16.37	-11.24	Pass
28.0180	33.78	28.88	10.21	43.99	39.09	60.00	50.00	-16.01	-10.91	Pass

Report No.: T210324W02-RP1

Test Mode:	Mode 1	Temp/Hum	24.3(°C)/ 55%RH
Phase:	Neutral	Test Date	May 7, 2021
Test Voltage:	120Vac, 60Hz	Test Engineer	Jerry Chang

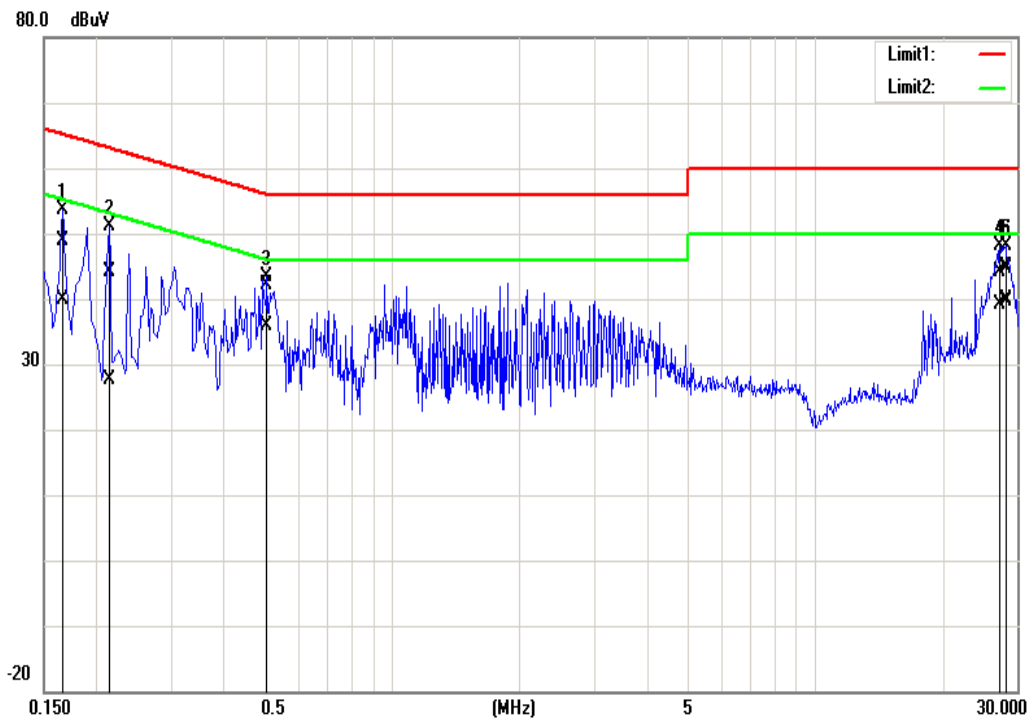

Frequency (MHz)	Quasi Peak reading (dBuV)	Average reading (dBuV)	Correction factor (dB)	Quasi Peak result (dBuV)	Average result (dBuV)	Quasi Peak limit (dBuV)	Average limit (dBuV)	Quasi Peak margin (dB)	Average margin (dB)	Remark
0.1660	38.74	29.69	10.26	49.00	39.95	65.16	55.16	-16.16	-15.21	Pass
0.2140	33.95	17.48	10.26	44.21	27.74	63.05	53.05	-18.84	-25.31	Pass
0.5060	31.95	25.69	10.26	42.21	35.95	56.00	46.00	-13.79	-10.05	Pass
27.3340	33.62	28.47	10.62	44.24	39.09	60.00	50.00	-15.76	-10.91	Pass
27.8940	34.37	29.23	10.63	45.00	39.86	60.00	50.00	-15.00	-10.14	Pass
28.1860	34.02	29.04	10.63	44.65	39.67	60.00	50.00	-15.35	-10.33	Pass

Report No.: T210324W02-RP1

4.2 6dB BANDWIDTH AND OCCUPIED BANDWIDTH (99%)

4.2.1 Test Limit

According to §15.247(a)(2)

6 dB Bandwidth :

Limit	Shall be at least 500kHz
-------	--------------------------

Occupied Bandwidth(99%) : For reporting purposes only.

4.2.2 Test Procedure

Test method Refer as ANSI C63.10: 2013,

1. The EUT RF output connected to the spectrum analyzer by RF cable.
2. Setting maximum power transmit of EUT
3. SA set RBW = 100kHz, VBW = 300kHz and Detector = Peak, to measurement 6 dB Bandwidth.
4. SA set RBW = 1% ~ 5% OBW, VBW = three times the RBW and Detector = Peak, to measurement 99% Bandwidth
5. Measure and record the result of 6 dB Bandwidth and 99% Bandwidth. in the test report.

4.2.3 Test Setup



Report No.: T210324W02-RP1

4.2.4 Test Result

Temperature: 23.9°C

Test date: May 6, 2021

Humidity: 51% RH

Tested by: Jack Chen

Test mode: IEEE 802.11b mode / 2412-2462 MHz						
Channel	Frequency (MHz)	Chain 0 OBW(99%) (MHz)	Chain 1 OBW(99%) (MHz)	Chain 0 6dB BW (MHz)	Chain 1 6dB BW (MHz)	6dB limit (kHz)
Low	2412	13.5021	-	9.087	-	≥500
Mid	2437	13.8929	-	9.5652	-	
High	2462	13.8694	-	10.0	-	

Test mode: IEEE 802.11g mode / 2412-2462 MHz						
Channel	Frequency (MHz)	Chain 0 OBW(99%) (MHz)	Chain 1 OBW(99%) (MHz)	Chain 0 6dB BW (MHz)	Chain 1 6dB BW (MHz)	6dB limit (kHz)
Low	2412	16.5846	-	16.5217	-	≥500
Mid	2437	16.5846	-	16.5217	-	
High	2462	16.5846	-	16.5217	-	

Test mode: IEEE 802.11n HT 20 MHz mode / 2412-2462 MHz						
Channel	Frequency (MHz)	Chain 0 OBW(99%) (MHz)	Chain 1 OBW(99%) (MHz)	Chain 0 6dB BW (MHz)	Chain 1 6dB BW (MHz)	6dB limit (kHz)
Low	2412	17.6700	-	17.6087	-	≥500
Mid	2437	17.6266	-	17.6087	-	
High	2462	17.6700	-	17.6087	-	

Test mode: IEEE 802.11n HT 40 mode / 2422-2452 MHz						
Channel	Frequency (MHz)	Chain 0 OBW(99%) (MHz)	Chain 1 OBW(99%) (MHz)	Chain 0 6dB BW (MHz)	Chain 1 6dB BW (MHz)	6dB limit (kHz)
Low	2422	36.8162	-	36.638	-	≥500
Mid	2437	36.9319	-	36.638	-	
High	2452	36.8162	-	36.638	-	

Test Data

6dB BANDWIDTH

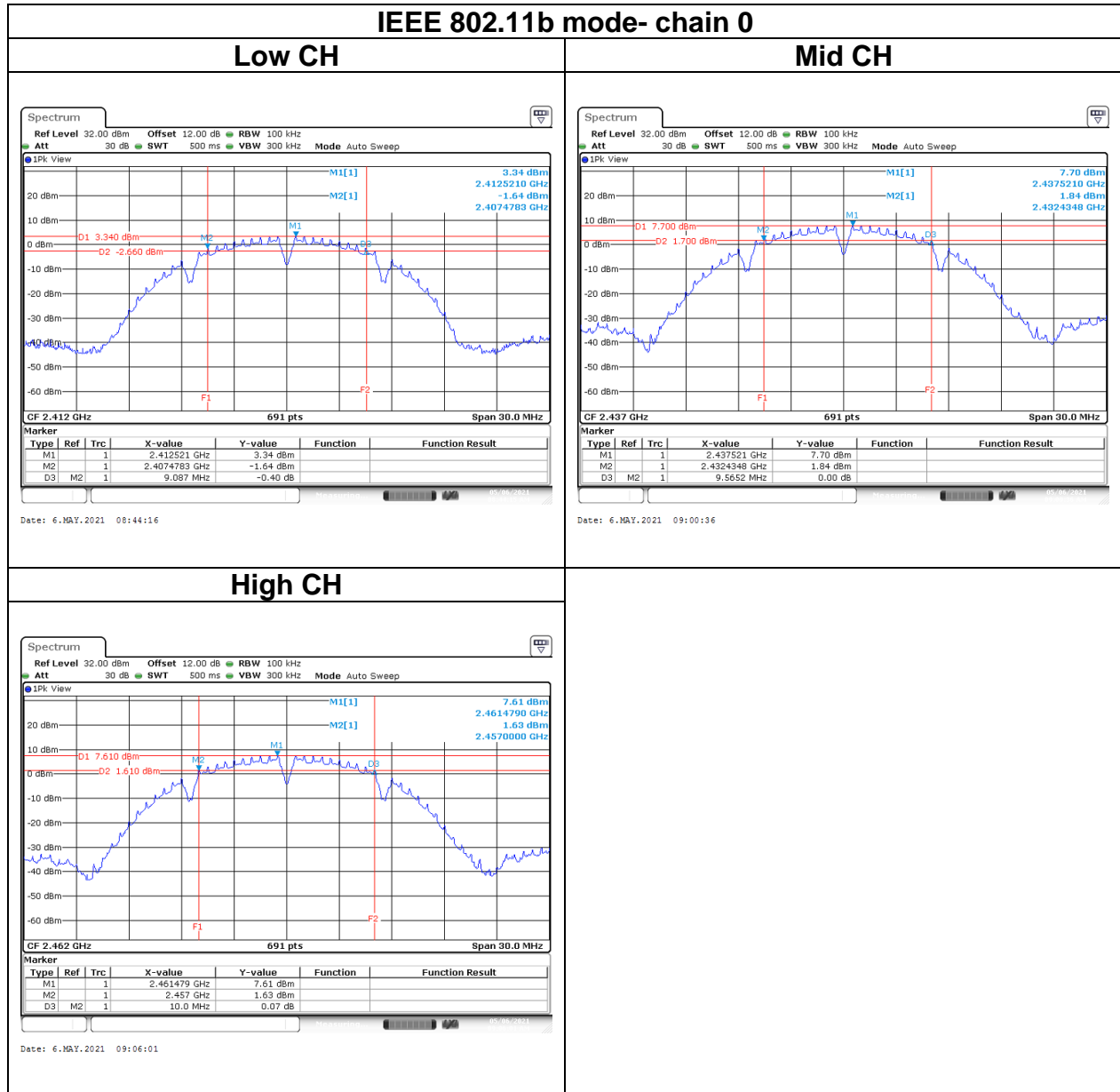

Report No.: T210324W02-RP1

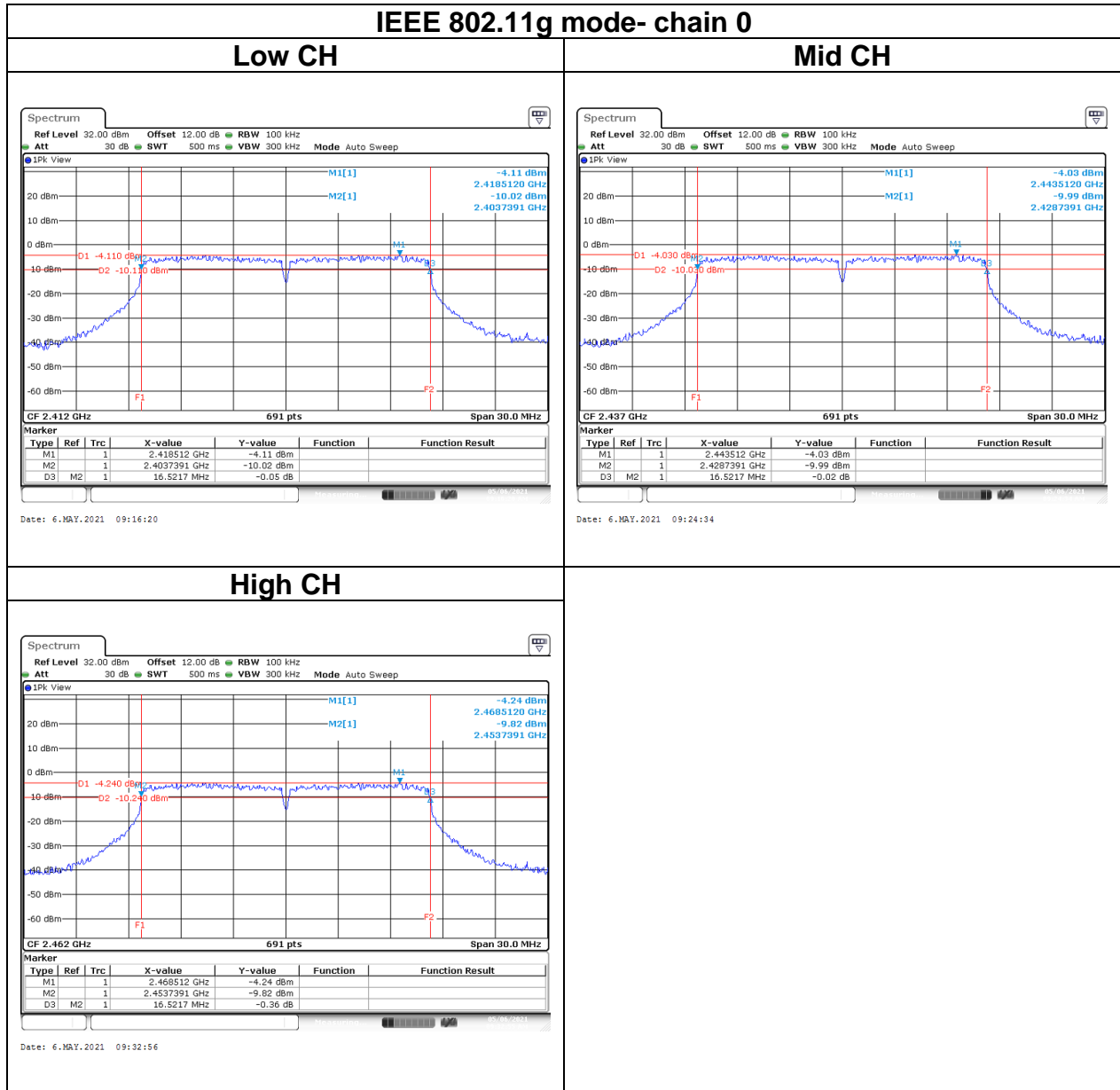

Report No.: T210324W02-RP1

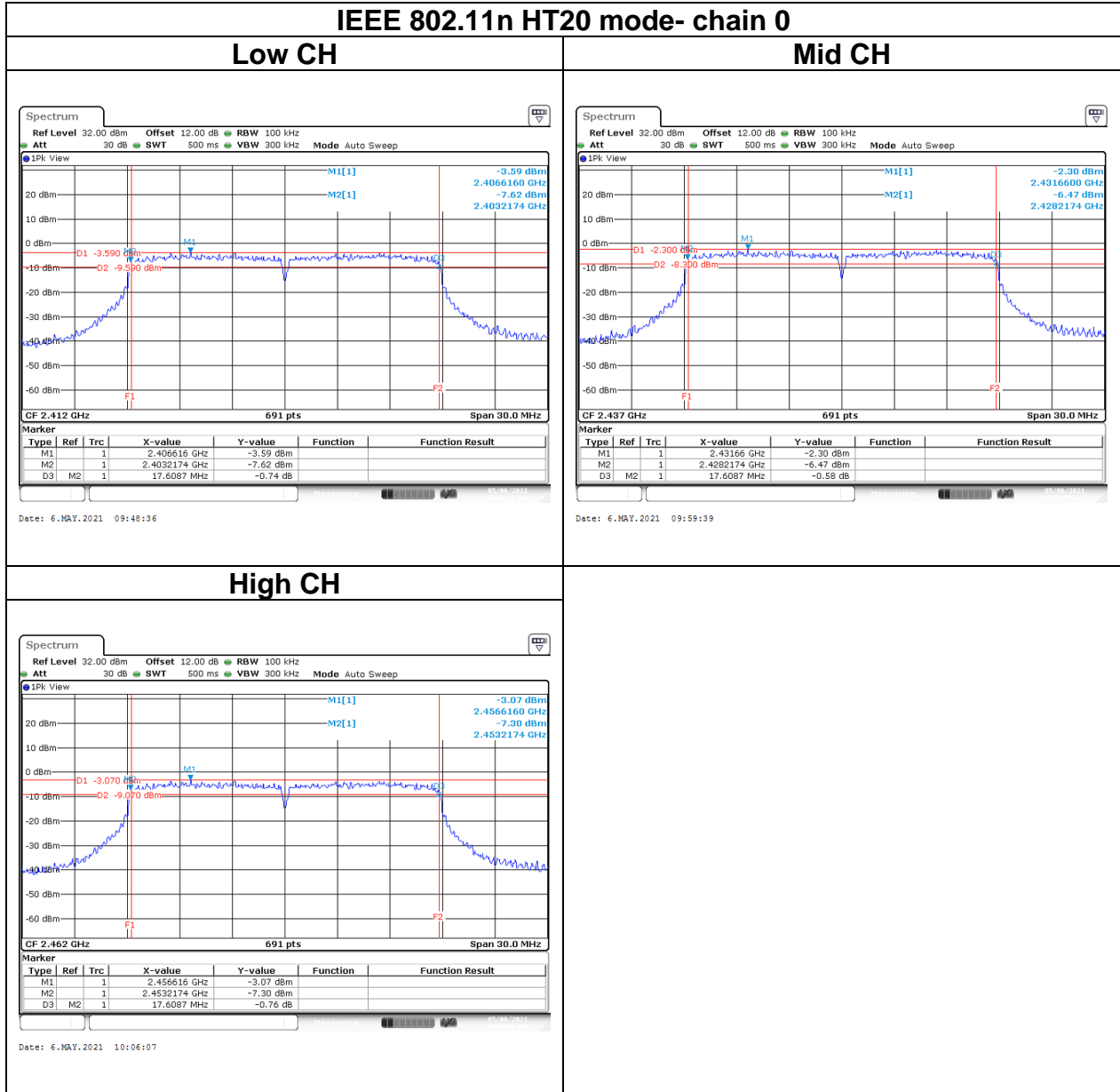

Report No.: T210324W02-RP1

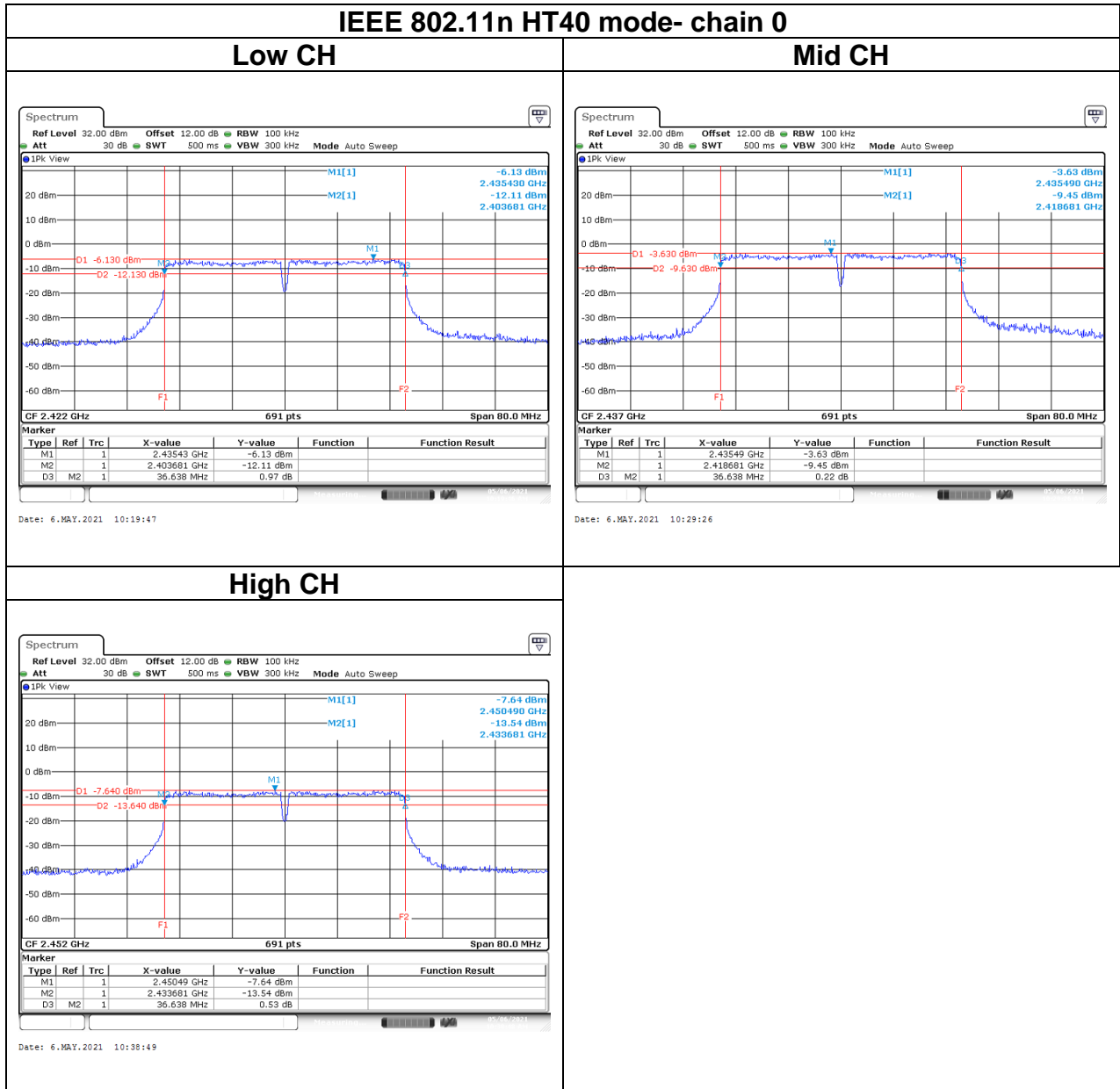

Report No.: T210324W02-RP1

Test Data

BANDWIDTH 99%

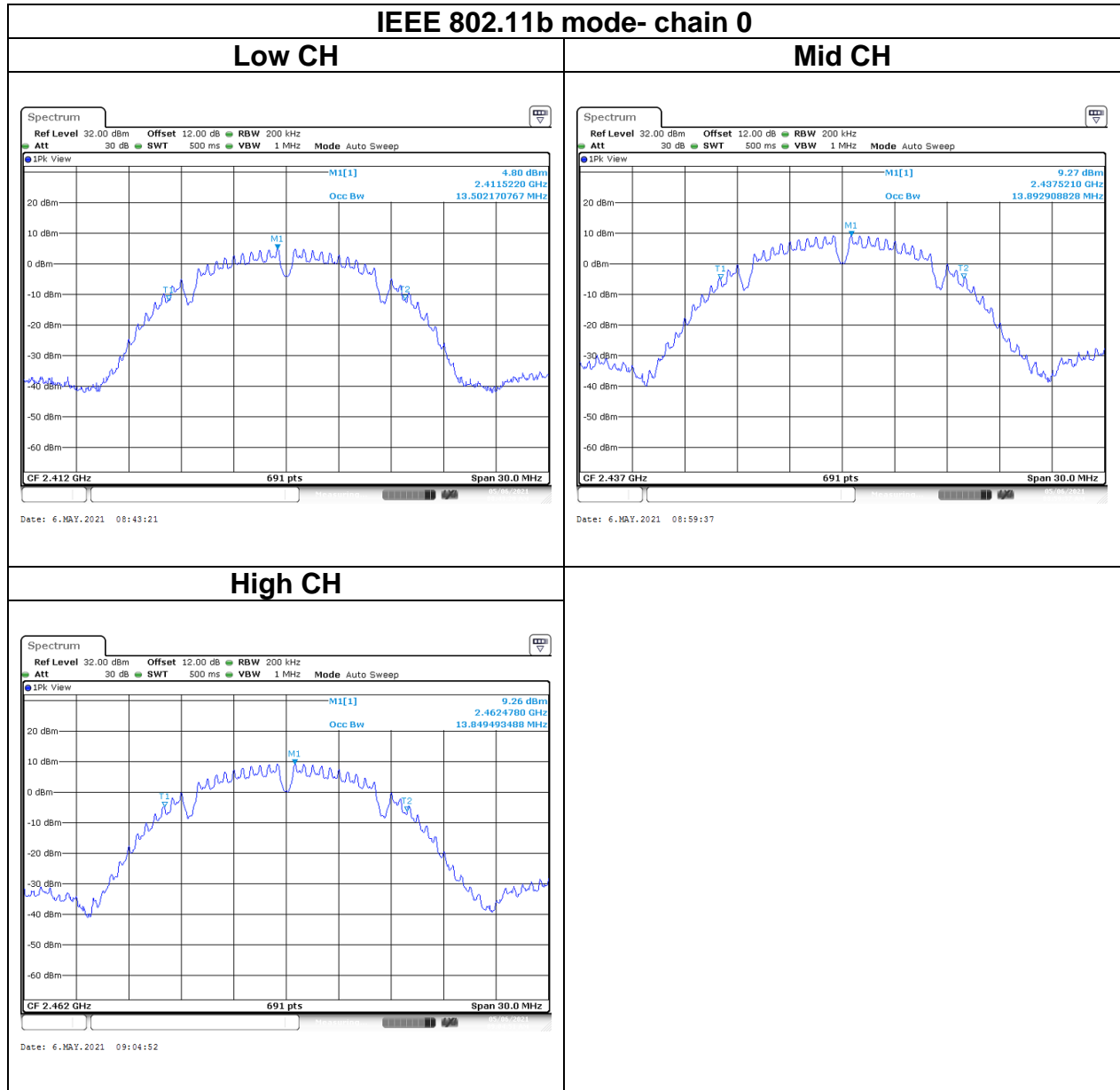

Report No.: T210324W02-RP1

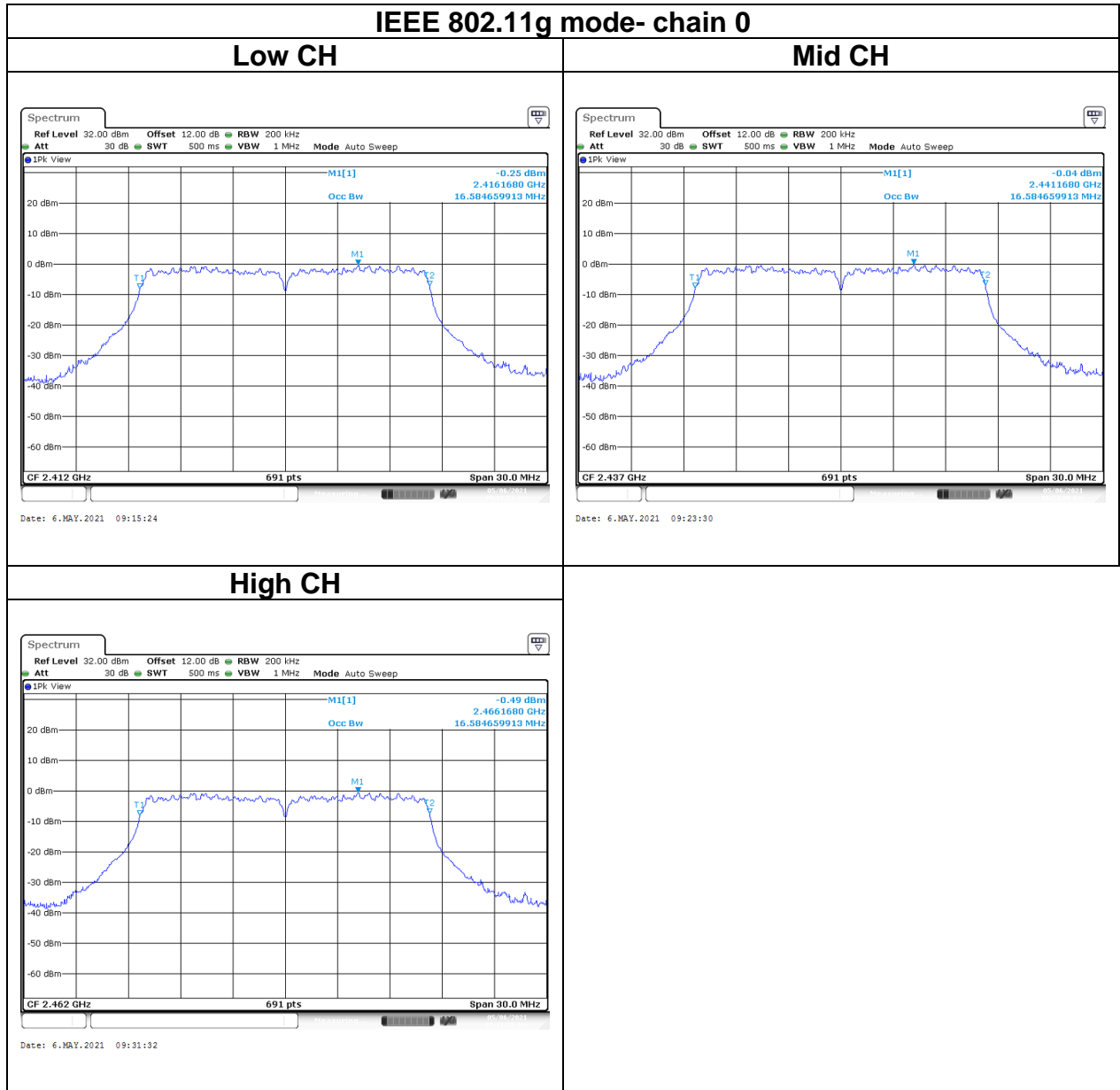

Report No.: T210324W02-RP1

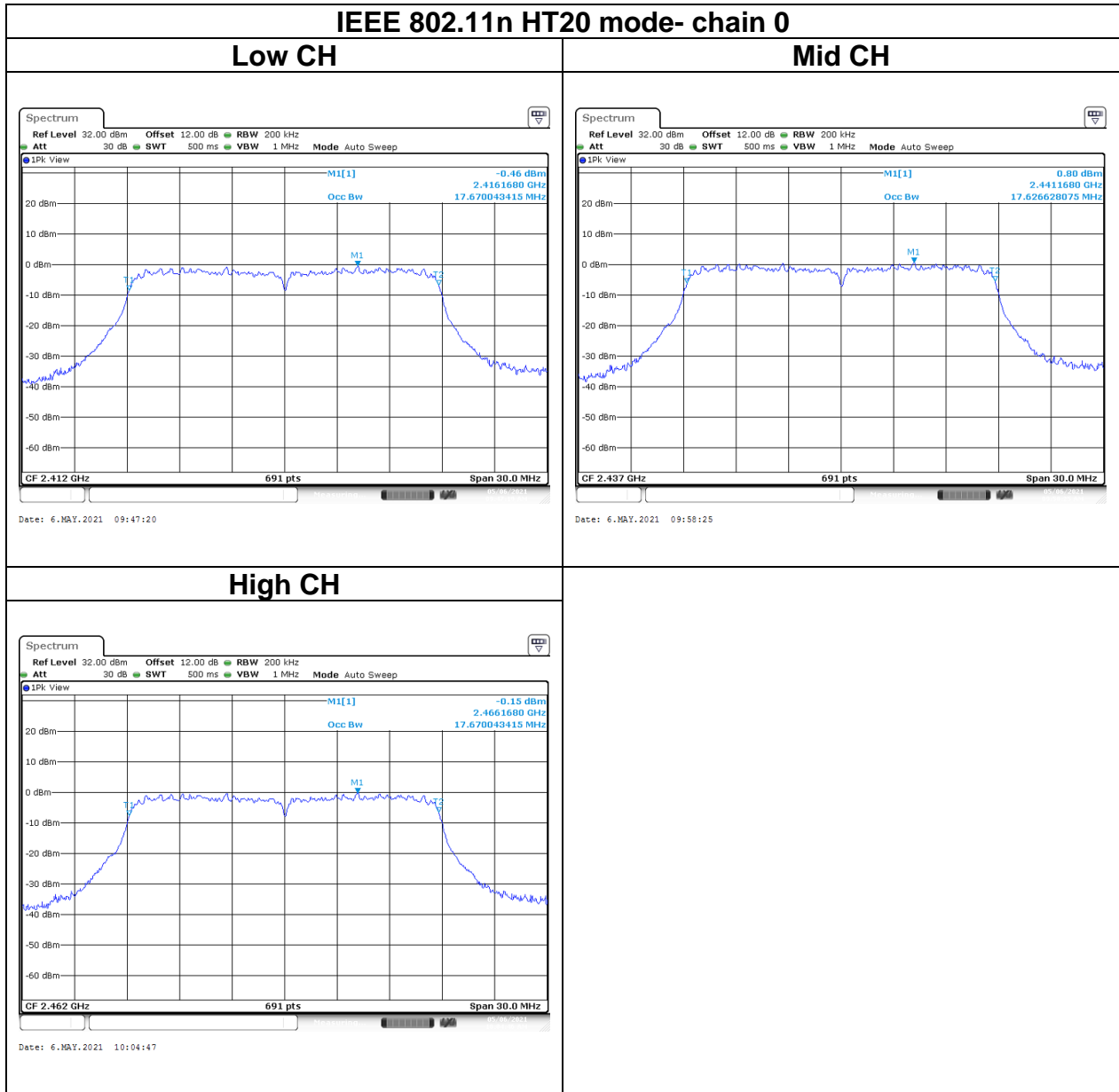

Report No.: T210324W02-RP1

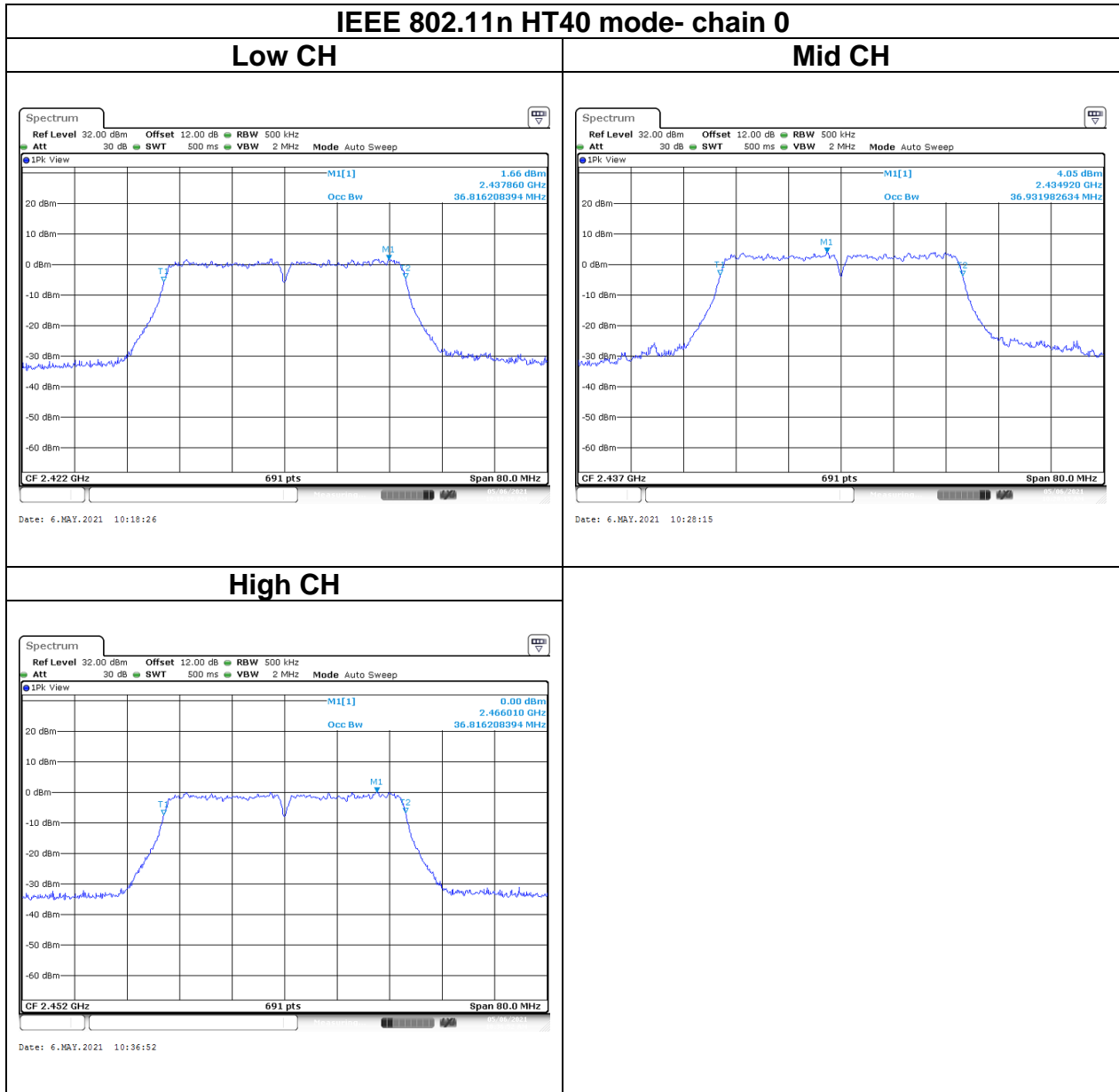

Report No.: T210324W02-RP1

4.3 OUTPUT POWER MEASUREMENT

4.3.1 Test Limit

According to §15.247(b),

Peak output power :

For systems using digital modulation in the 2400-2483.5 MHz, and 5725-5850 MHz bands: 1 Watt(30 dBm) and the e.i.r.p. shall not exceed 4Watt(36 dBm), base on the use of antennas with directional gain not exceed 6 dBi If transmitting antennas of directional gain greater than 6dBi are used the peak output power the conducted output power from the intentional radiator shall be reduced by the amount in dB that the directional gain of the antenna exceeds 6 dBi. In case of point-to-point operation, the limit has to be reduced by 1dB for every 3 dB that the directional gain of the antenna exceeds 6 dBi.

Limit	<input checked="" type="checkbox"/> Antenna not exceed 6 dBi : 30dBm <input type="checkbox"/> Antenna with DG greater than 6 dBi : [Limit = 30 – (DG – 6)] <input type="checkbox"/> Point-to-point operation :
-------	---

Average output power : For reporting purposes only.

4.3.2 Test Procedure

Test method Refer as ANSI C63.10:2013.

1. The EUT RF output connected to the power meter by RF cable.
2. Setting maximum power transmit of EUT.
3. The path loss was compensated to the results for each measurement.
4. Measure and record the result of Peak output power and Average output power. in the test report.

4.3.3 Test Setup

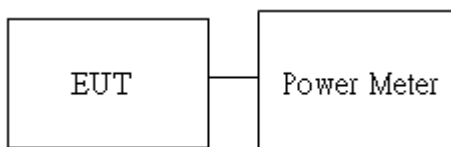

Report No.: T210324W02-RP1

4.3.4 Test Result

Temperature: 23.9°C

Test date:

May 6, 2021

Humidity: 51% RH

Tested by:

Jack Chen

Peak output power :

Wifi 2.4G								
Config	CH	Freq. (MHz)	Power Setting	PK Power (dBm)	PK Total Power (dBm)	PK Total Power (W)	Ant. Gain (dBi)	Limit (dBm)
IEEE 802.11b Data rate: 1Mbps	Low	2412	53	23.11	23.11	0.2046	4	30
	Mid	2437	53	23.16	23.16	0.2070		
	High	2462	52	23.02	23.02	0.2004		
IEEE 802.11g Data rate: 6Mbps	Low	2412	43	23.39	23.39	0.2183		
	Mid	2437	43	23.29	23.29	0.2133		
	High	2462	42	22.95	22.95	0.1972		
IEEE 802.11n HT20 Data rate: MCS0	Low	2412	45	23.09	23.09	0.2037		
	Mid	2437	45	23.07	23.07	0.2028		
	High	2462	45	23.06	23.06	0.2023		
IEEE 802.11n HT40 Data rate: MCS0	Low	2422	44	22.98	22.98	0.1986		
	Mid	2437	48	23.92	23.92	0.2466		
	High	2452	39	21.08	21.08	0.1282		

Report No.: T210324W02-RP1

Average output power :

Wifi 2.4G				
Config	CH	Freq. (MHz)	Power Setting	AV Power (dBm)
IEEE 802.11b Data rate: 1Mbps	Low	2412	53	21.68
	Mid	2437	53	20.87
	High	2462	52	20.53
IEEE 802.11g Data rate: 6Mbps	Low	2412	43	14.16
	Mid	2437	43	14.21
	High	2462	42	13.79
IEEE 802.11n HT20 Data rate: MCS0	Low	2412	45	14.99
	Mid	2437	45	14.98
	High	2462	45	14.97
IEEE 802.11n HT40 Data rate: MCS0	Low	2422	44	14.73
	Mid	2437	48	14.38
	High	2452	39	12.59

Report No.: T210324W02-RP1

4.4 POWER SPECTRAL DENSITY

4.4.1 Test Limit

According to §15.247(e),

For digitally modulated systems, the power spectral density conducted from the intentional radiator to the antenna shall not be greater than 8 dBm in any 3 kHz band during any time interval of continuous transmission.

Limit	<input checked="" type="checkbox"/> Antenna not exceed 6 dBi : 8dBm <input type="checkbox"/> Antenna with DG greater than 6 dBi : [Limit = 8 – (DG – 6)] <input type="checkbox"/> Point-to-point operation :
-------	---

4.4.2 Test Procedure

Test method Refer as ANSI C63.10:2013,

1. The EUT RF output connected to the spectrum analyzer by RF cable.
2. Setting maximum power transmit of EUT
3. SA set RBW = 3kHz, VBW = 30kHz, Span = 1.5 times DTS Bandwidth (6 dB BW), Detector = Peak, Sweep Time = Auto and Trace = Max hold.
4. The path loss and Duty Factor were compensated to the results for each measurement by SA.
5. Mark the maximum level.
6. Measure and record the result of power spectral density. in the test report.

4.4.3 Test Setup

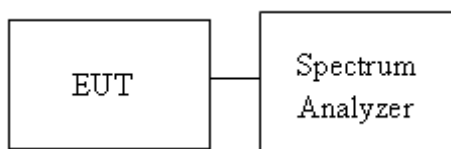

Report No.: T210324W02-RP1

4.4.4 Test Result

Temperature: 23.9°C

Test date: May 6, 2021

Humidity: 51% RH

Tested by: Jack Chen

Test mode: IEEE 802.11b mode / 2412-2462 MHz					
Channel	Frequency (MHz)	Chain 0 PPSD (dBm)	Chain 1 PPSD (dBm)	Total PPSD (dBm)	Limit (dBm)
Low	2412	-12.62	-	-12.62	8
Mid	2437	-12.29	-	-12.29	
High	2462	-12.43	-	-12.43	

Test mode: IEEE 802.11g mode / 2412-2462 MHz					
Channel	Frequency (MHz)	Chain 0 PPSD (dBm)	Chain 1 PPSD (dBm)	Total PPSD (dBm)	Limit (dBm)
Low	2412	-18.66	-	-18.66	8
Mid	2437	-18.52	-	-18.52	
High	2462	-18.36	-	-18.36	

Test mode: IEEE 802.11n HT 20 MHz mode / 2412-2462 MHz					
Channel	Frequency (MHz)	Chain 0 PPSD (dBm)	Chain 1 PPSD (dBm)	Total PPSD (dBm)	Limit (dBm)
Low	2412	-17.82	-	-17.82	8
Mid	2437	-16.83	-	-16.83	
High	2462	-17.15	-	-17.15	

Test mode: IEEE 802.11n HT 40 mode / 2422-2452 MHz					
Channel	Frequency (MHz)	Chain 0 PPSD (dBm)	Chain 1 PPSD (dBm)	Total PPSD (dBm)	Limit (dBm)
Low	2422	-17.13	-	-17.13	8
Mid	2437	-15.09	-	-15.09	
High	2452	-19.1	-	-19.1	

Test Data

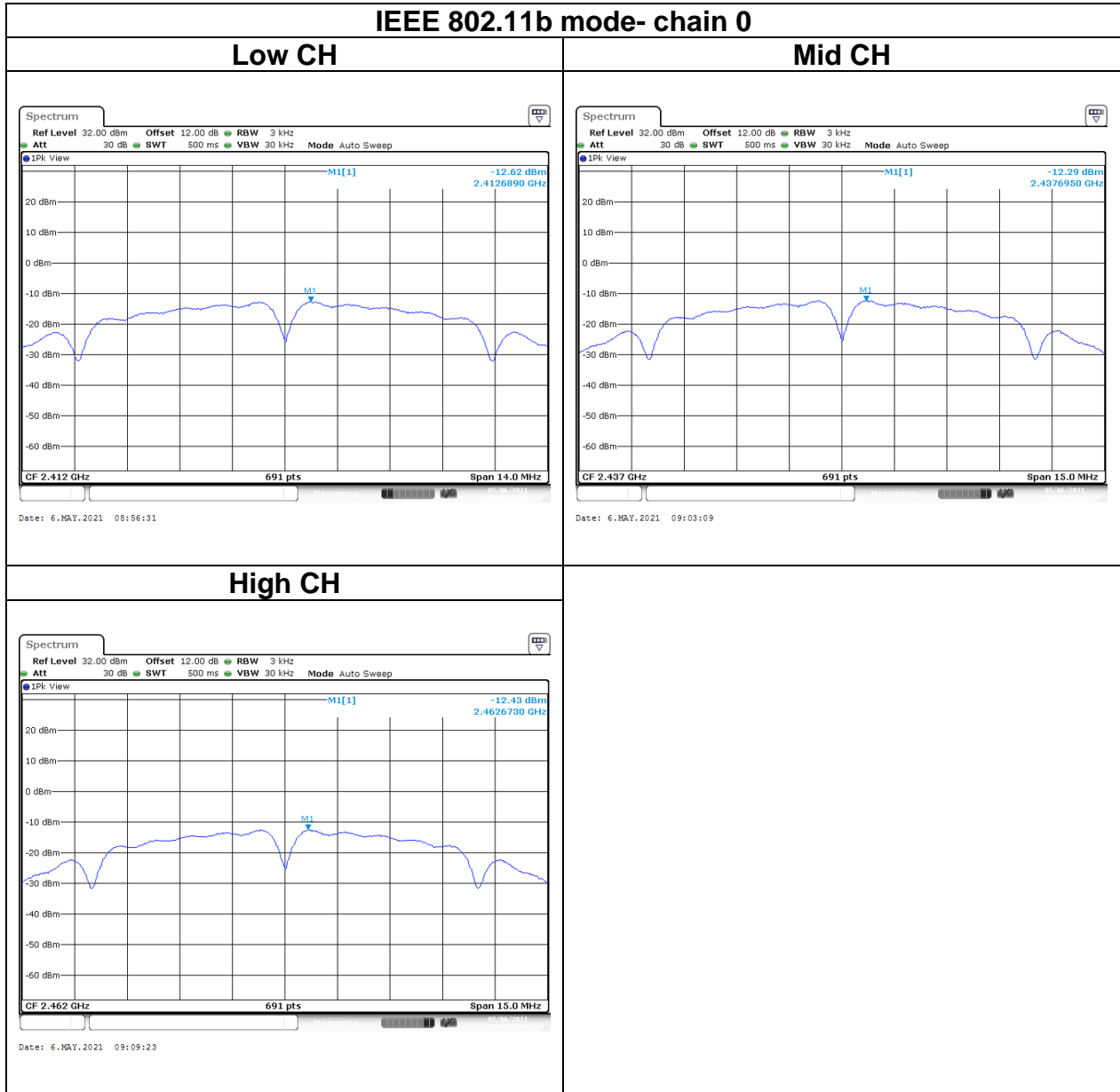

Report No.: T210324W02-RP1

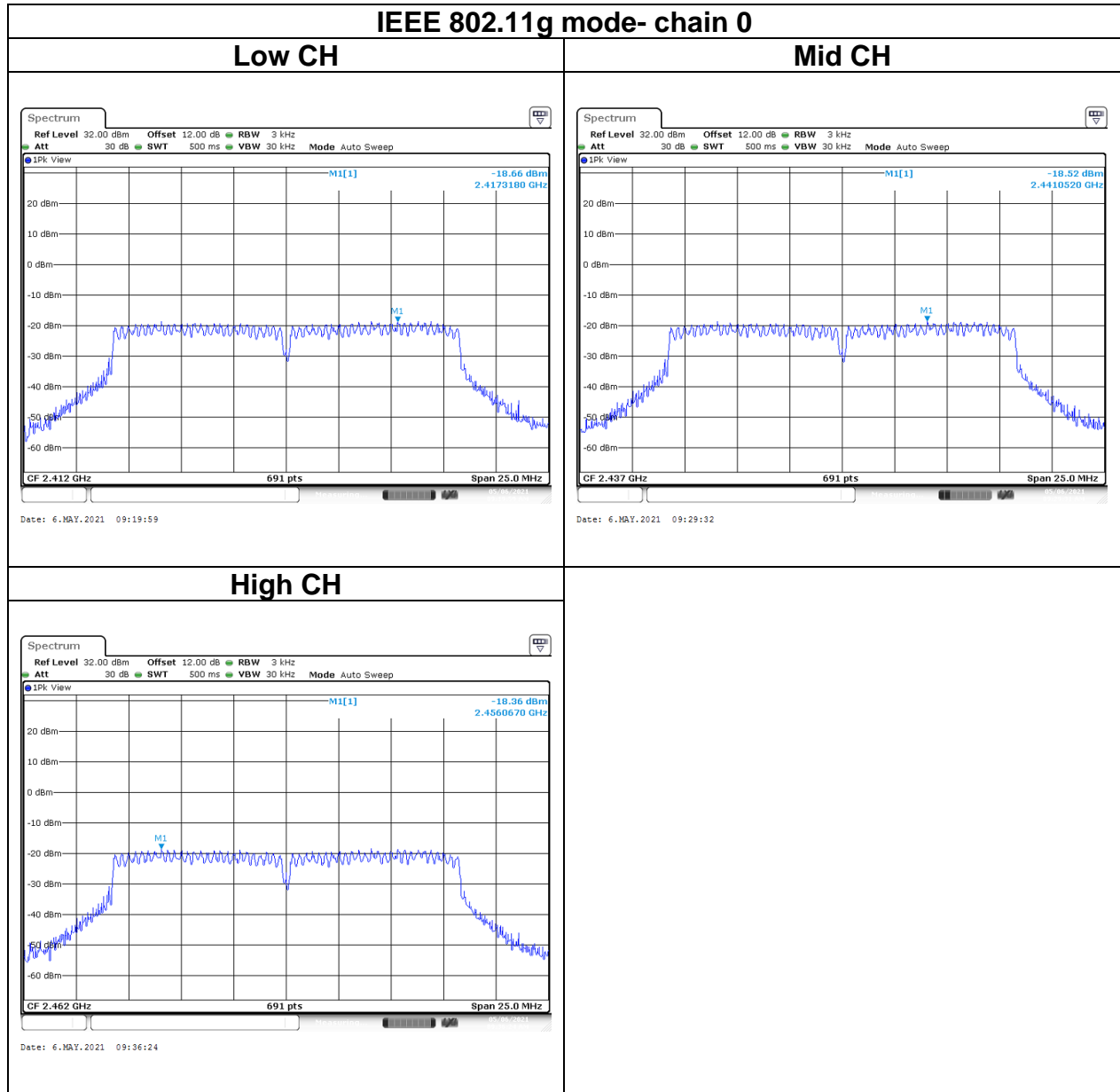

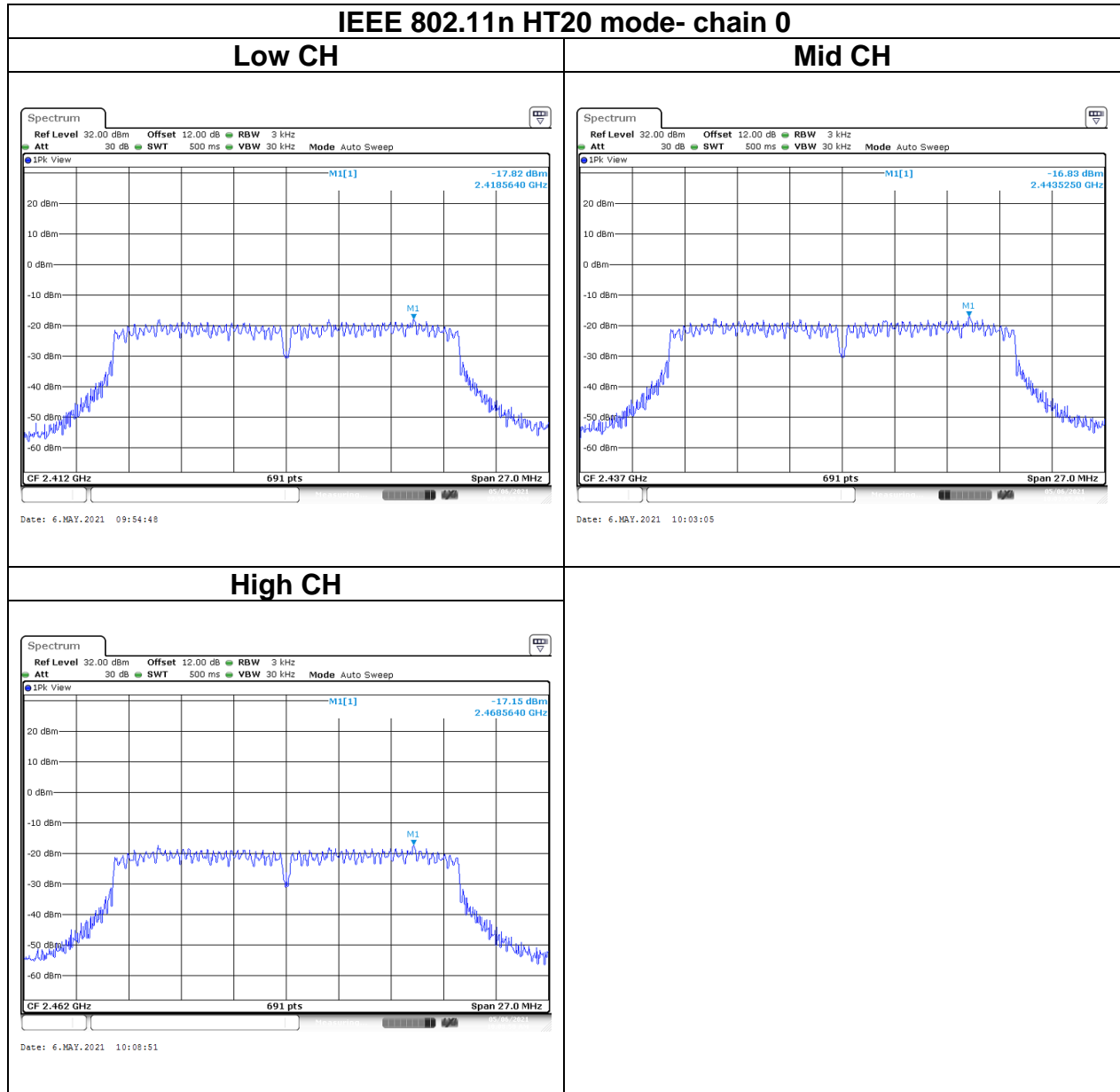

Report No.: T210324W02-RP1

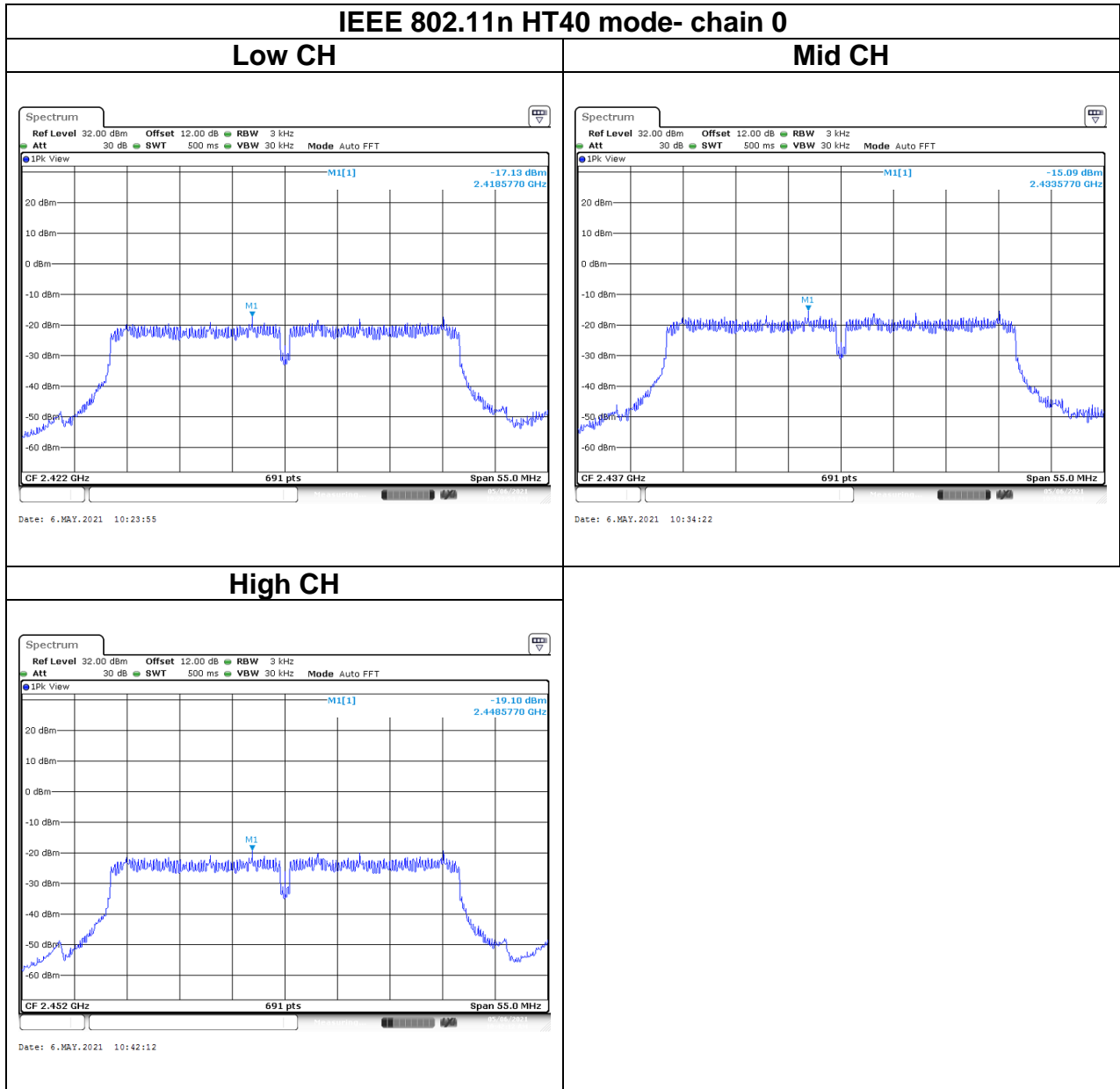

4.5 CONDUCTED BANDEDGE AND SPURIOUS EMISSION

4.5.1 Test Limit

According to §15.247(d),

In any 100 kHz bandwidth outside the authorized frequency band,

Non-restricted bands shall be attenuated at least 20 dB/30 dB relative to the maximum PSD level in 100 kHz by RF conducted or a radiated measurement which fall in the restricted bands, as defined in §15.205(a), must also comply with the radiated emission limits specified in §15.209(a).

4.5.2 Test Procedure

Test method Refer as ANSI C63.10:2013.

1. EUT RF output port connected to the SA by RF cable, and the path loss was compensated to result.
2. SA setting, RBW=100kHz, VBW=300kHz, Detector=Peak, Trace mode = max hold, SWT = Auto.
3. In any 100 kHz bandwidth outside the authorized frequency band, shall be attenuated at least 20 dB relative to the maximum in-band peak PSD level in 100 kHz when conducted power procedure is used. If the transmitter complies with the conducted power limits based on the use of RMS averaging over a time interval, the attenuation required under this paragraph shall be 30 dB instead of 20 dB.

4.5.3 Test Setup

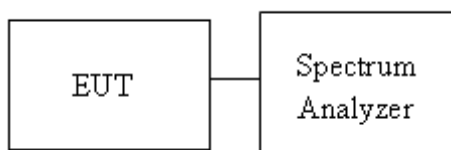

4.5.4 Test Result

Temperature: 23.9°C

Test date: May 6, 2021

Humidity: 51% RH

Tested by: Jack Chen

Test Data

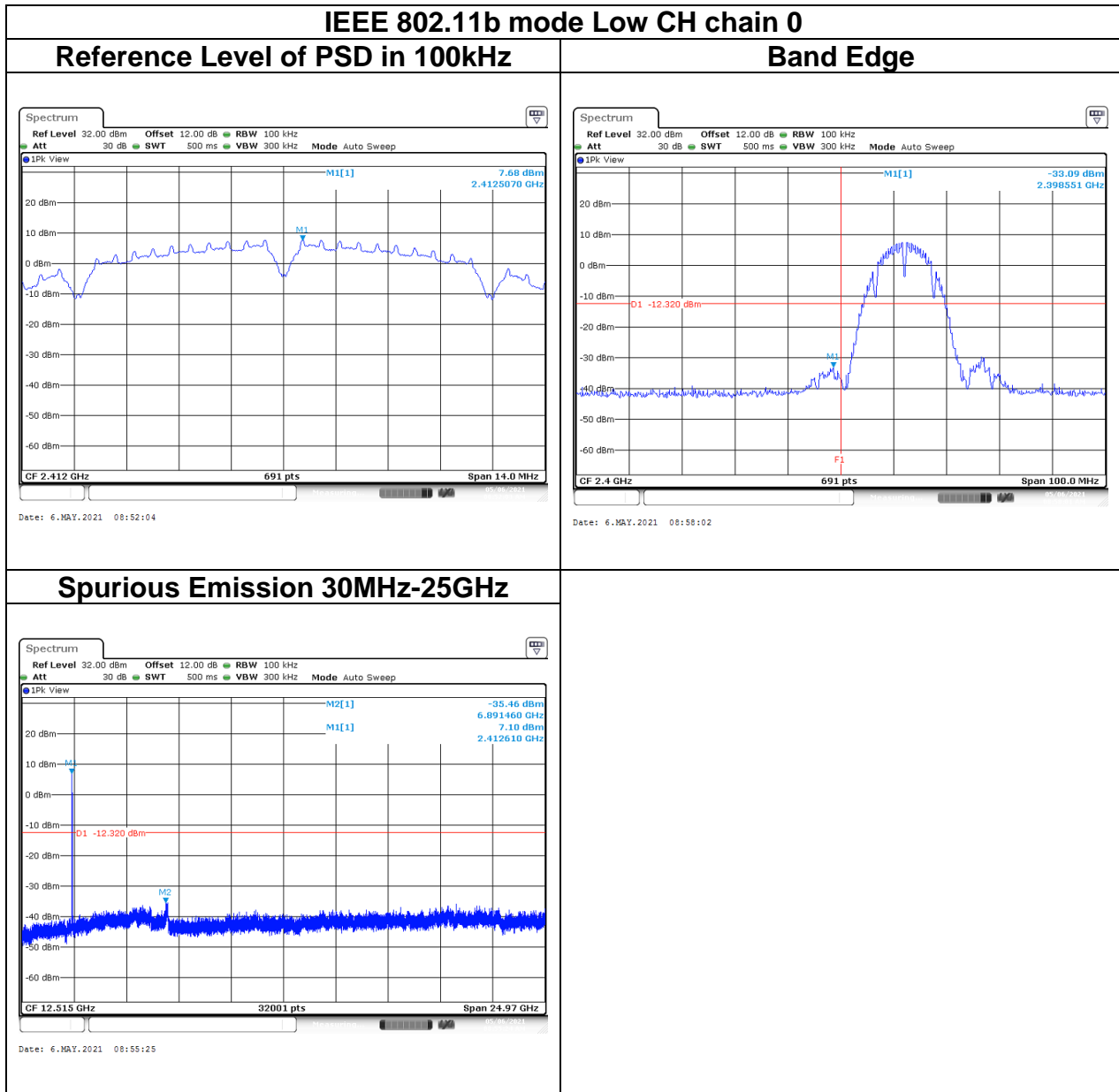

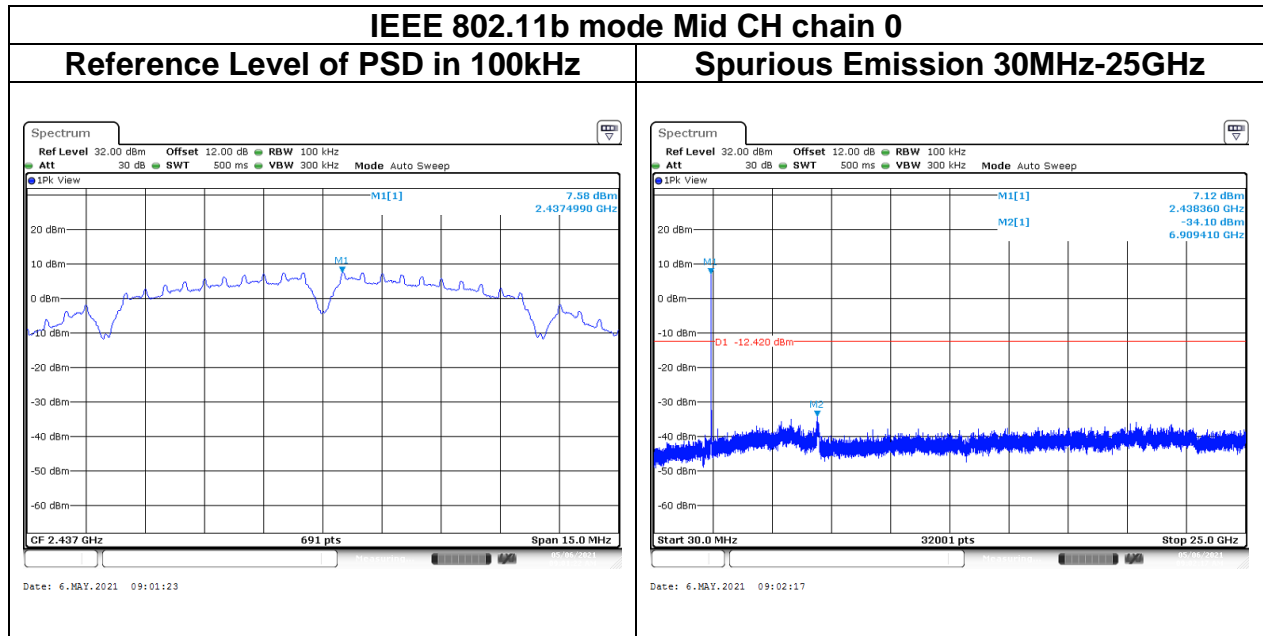

Report No.: T210324W02-RP1

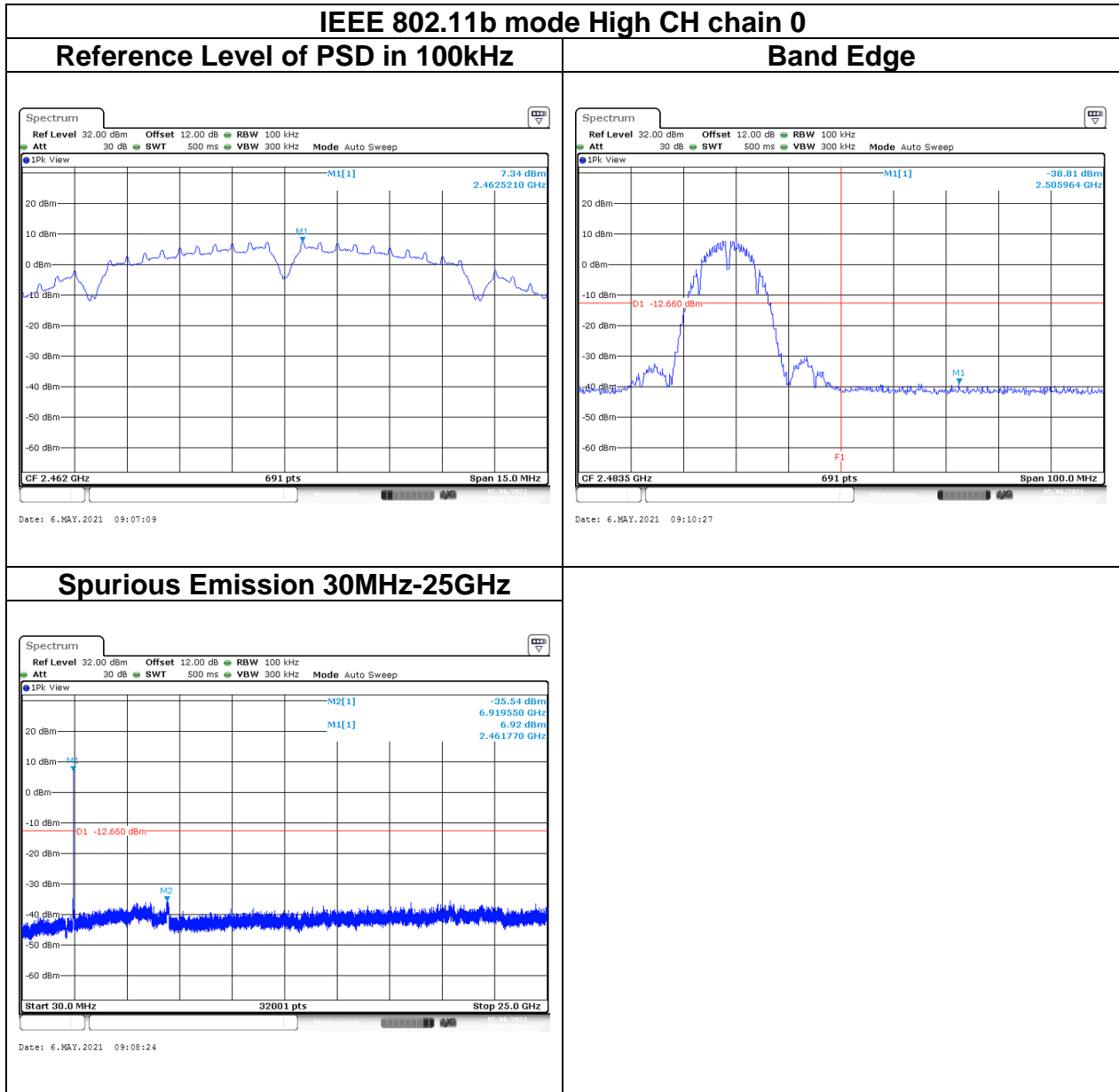

Report No.: T210324W02-RP1

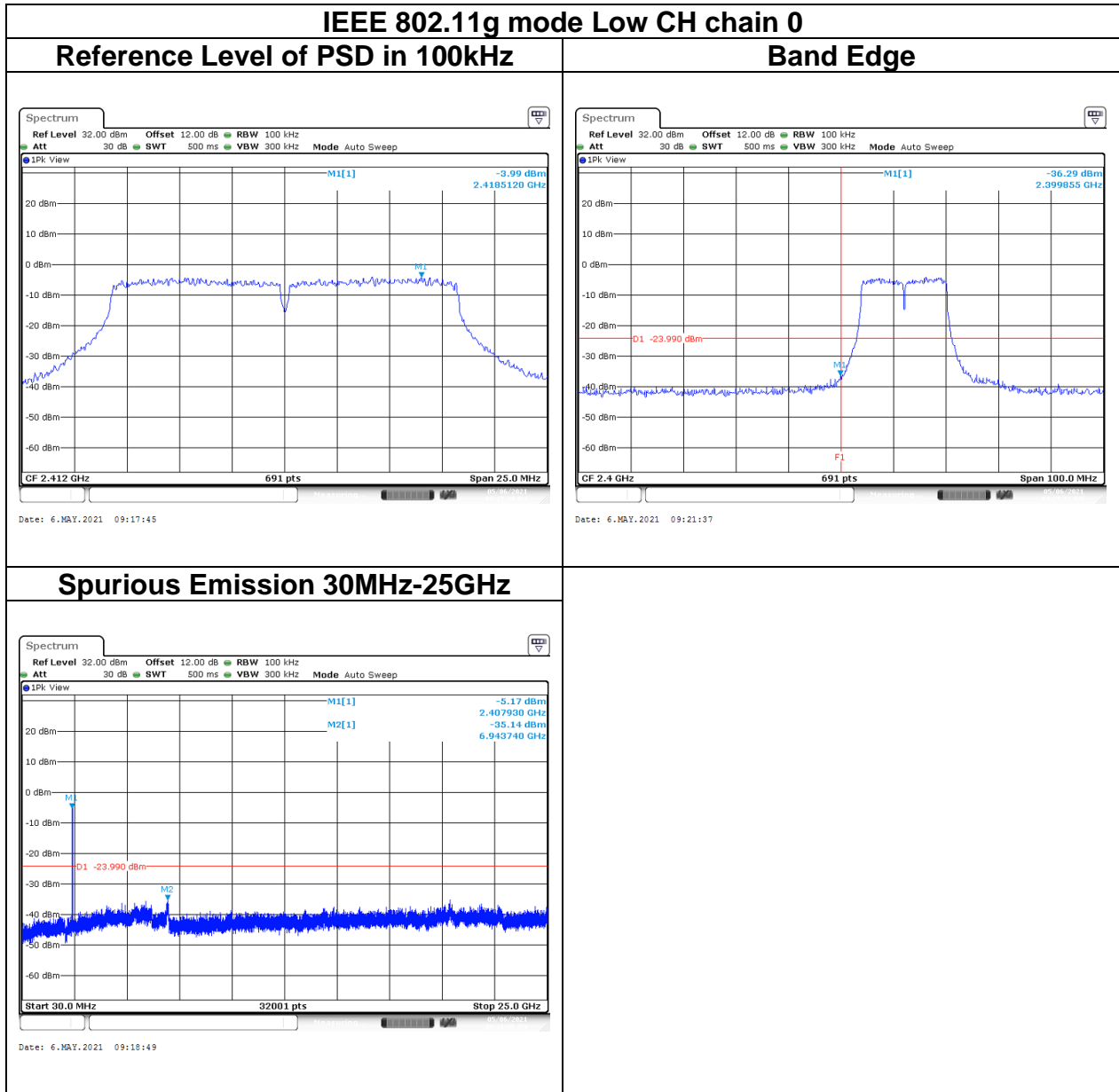

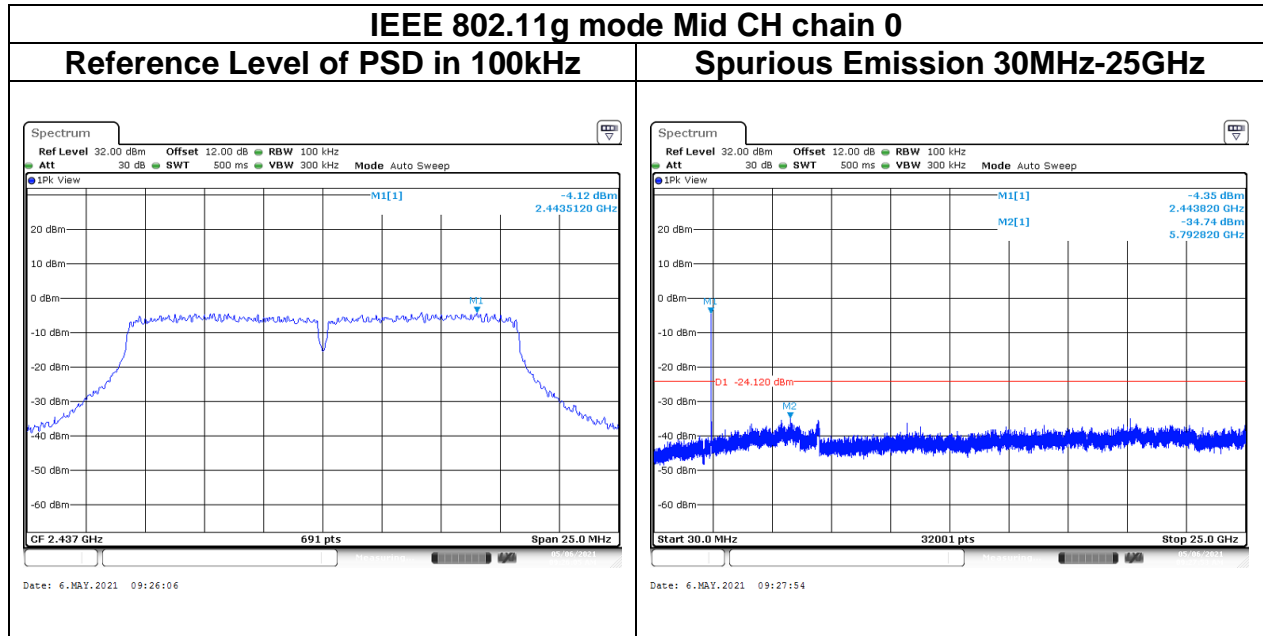

Report No.: T210324W02-RP1

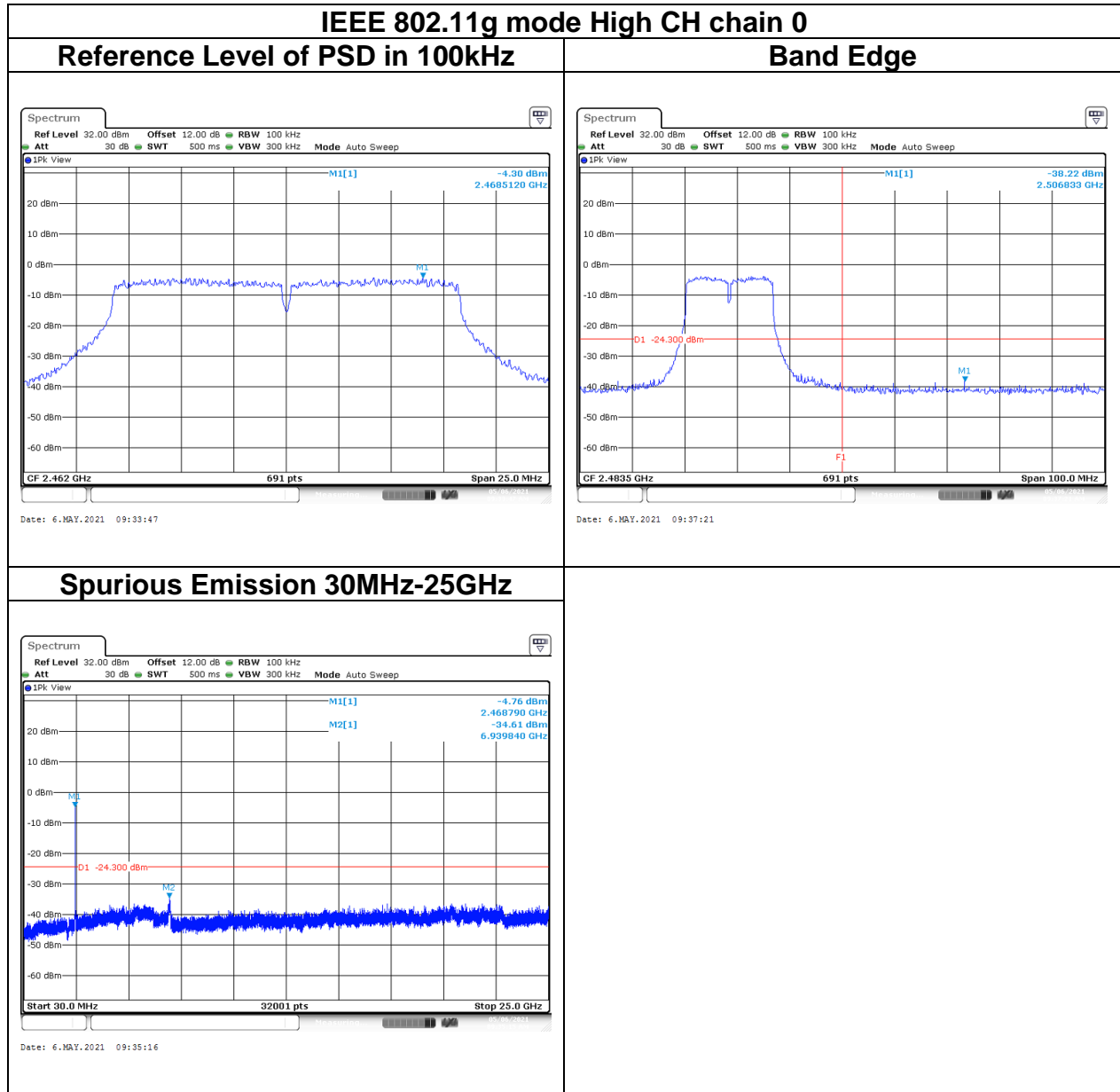

Report No.: T210324W02-RP1

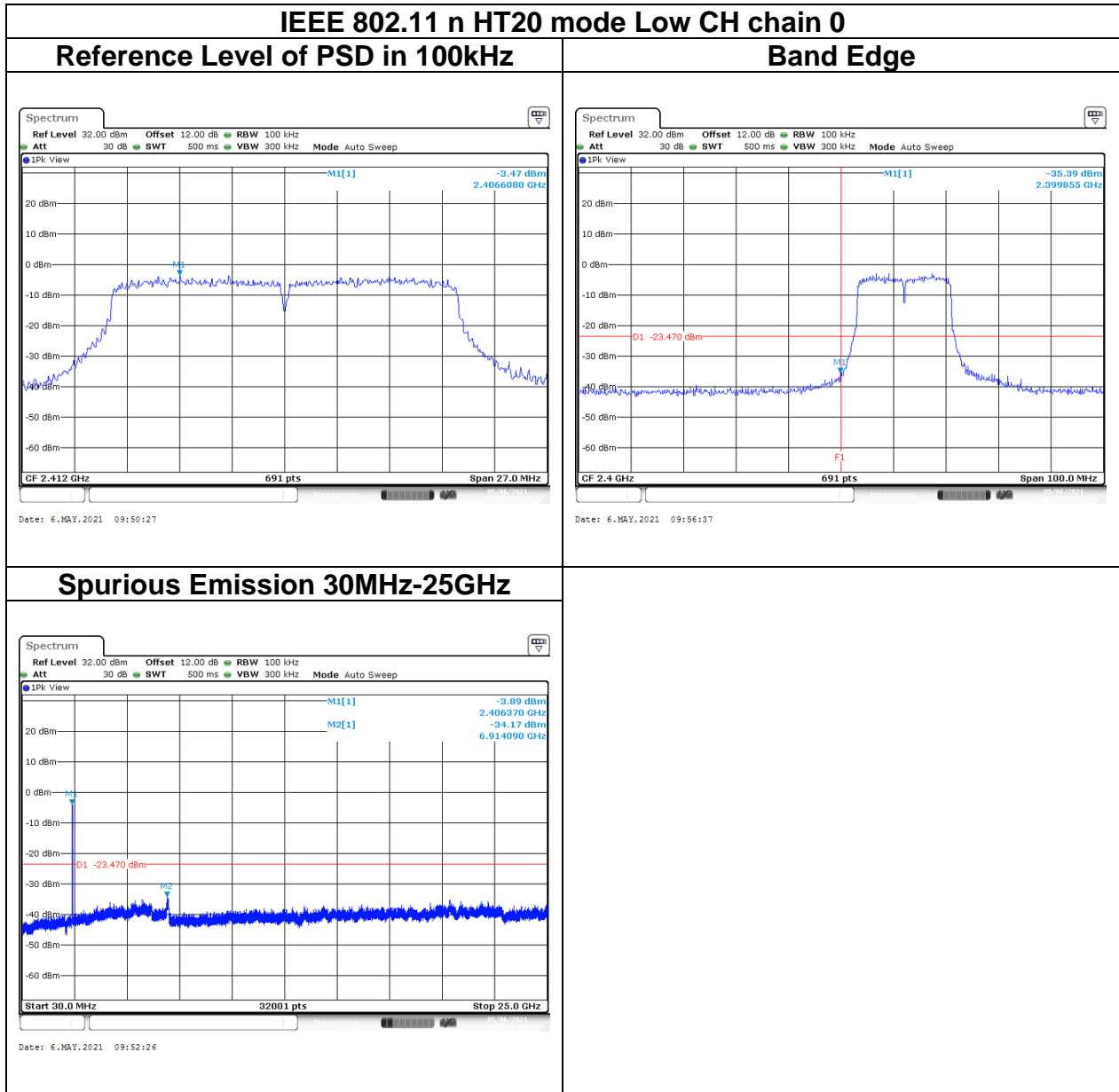

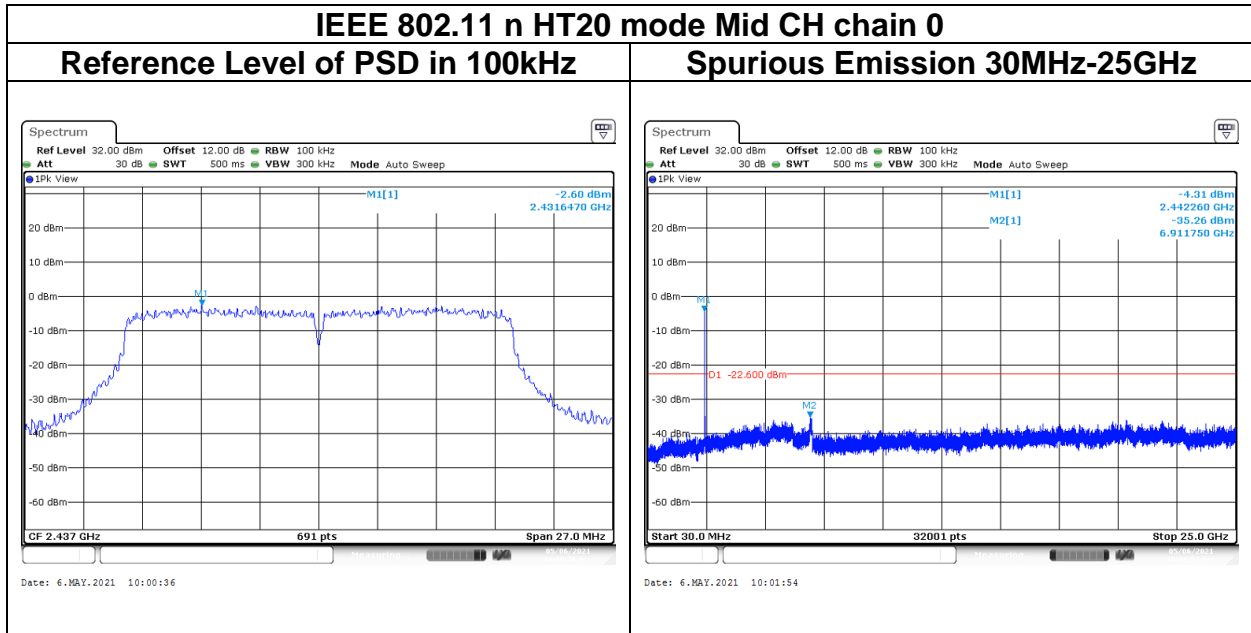

Report No.: T210324W02-RP1

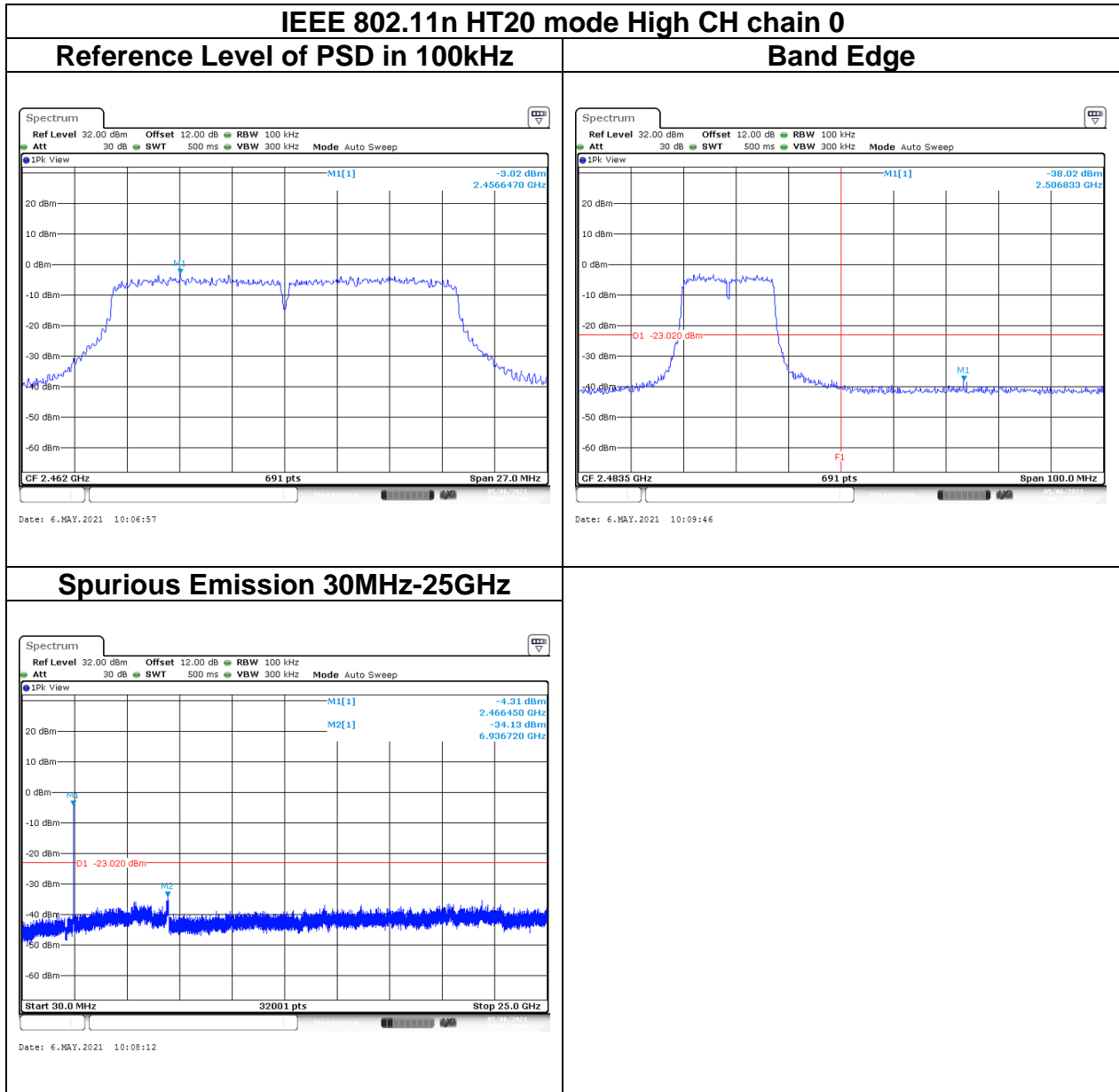

Report No.: T210324W02-RP1

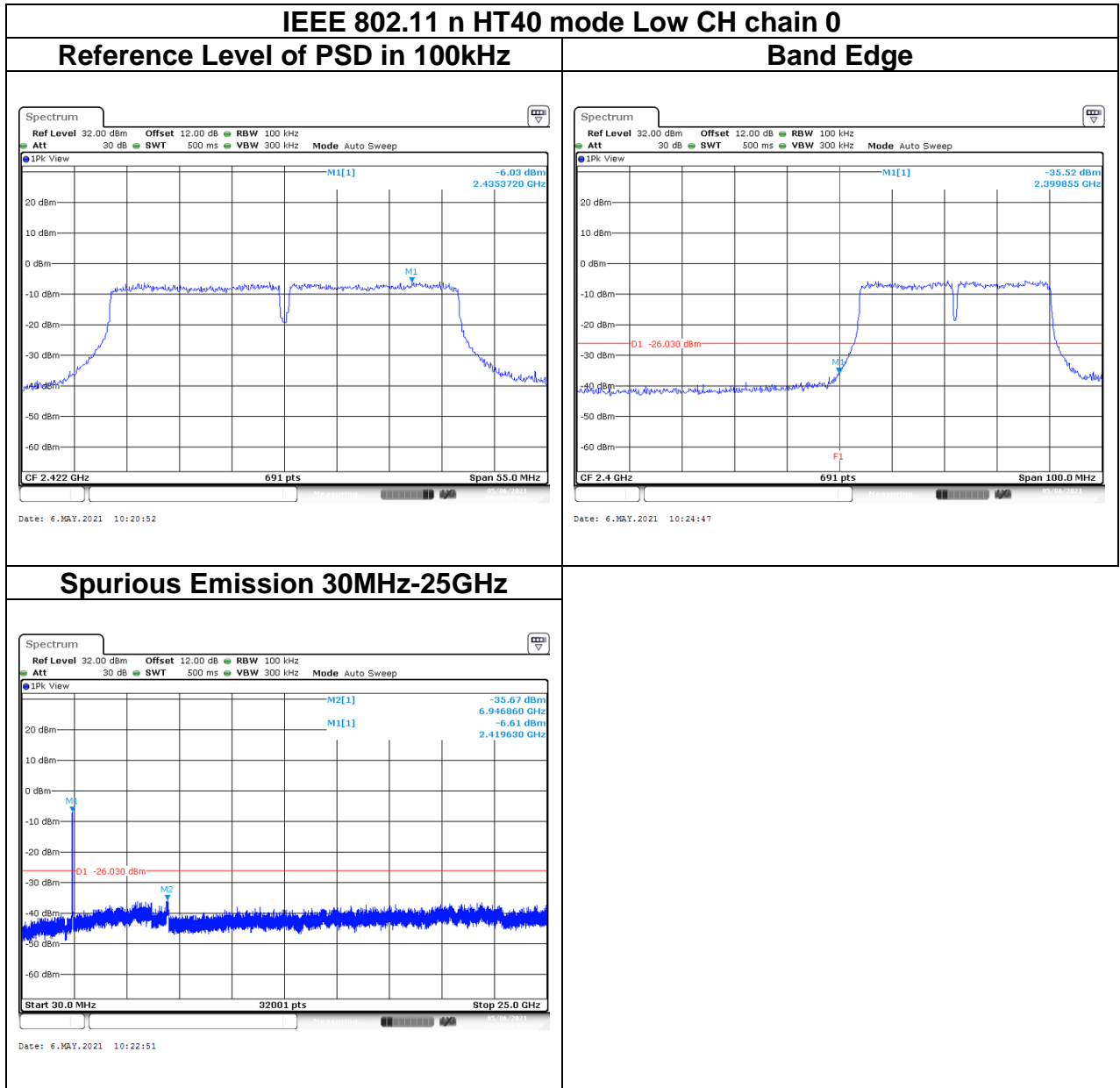

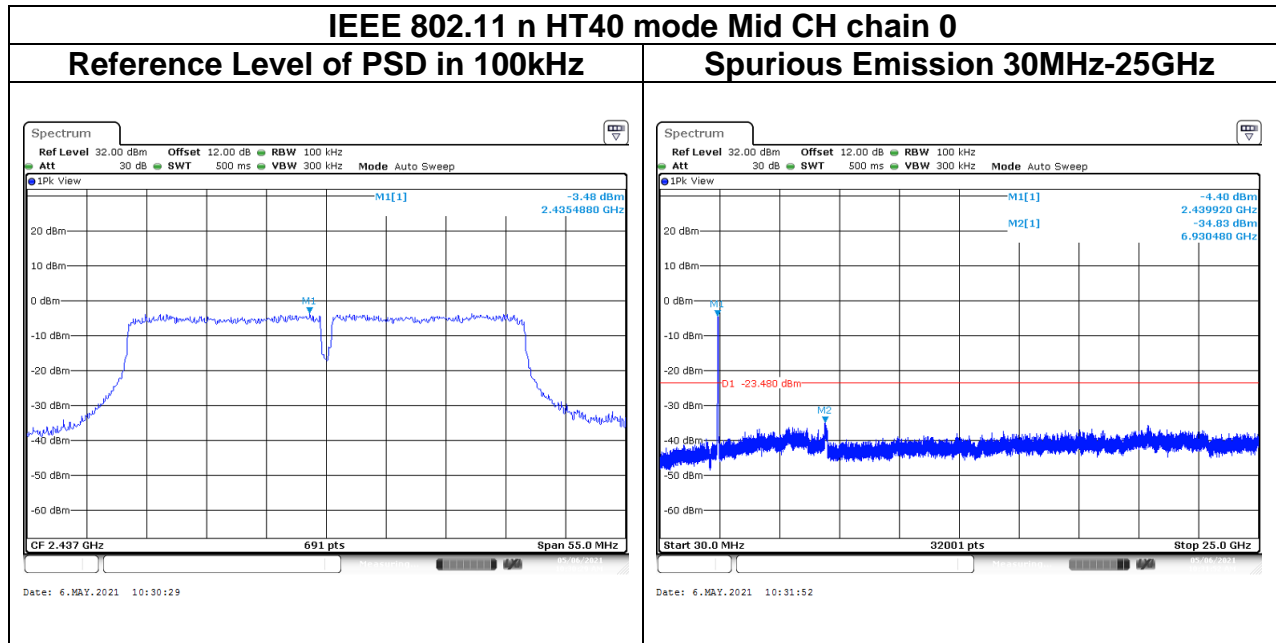

Report No.: T210324W02-RP1

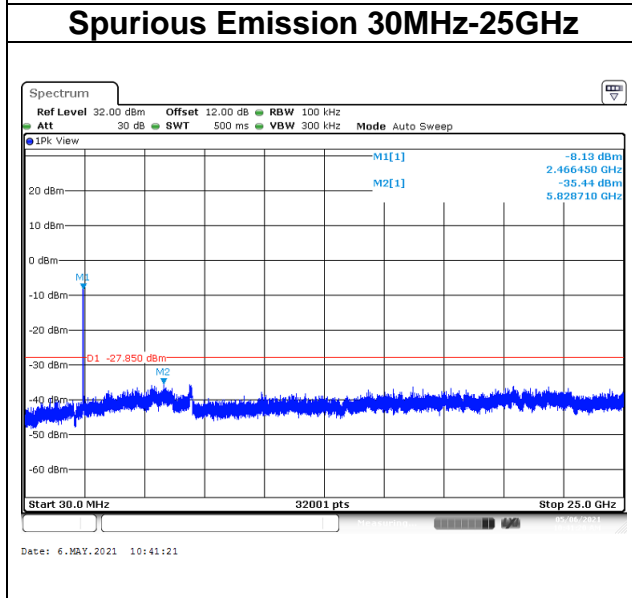
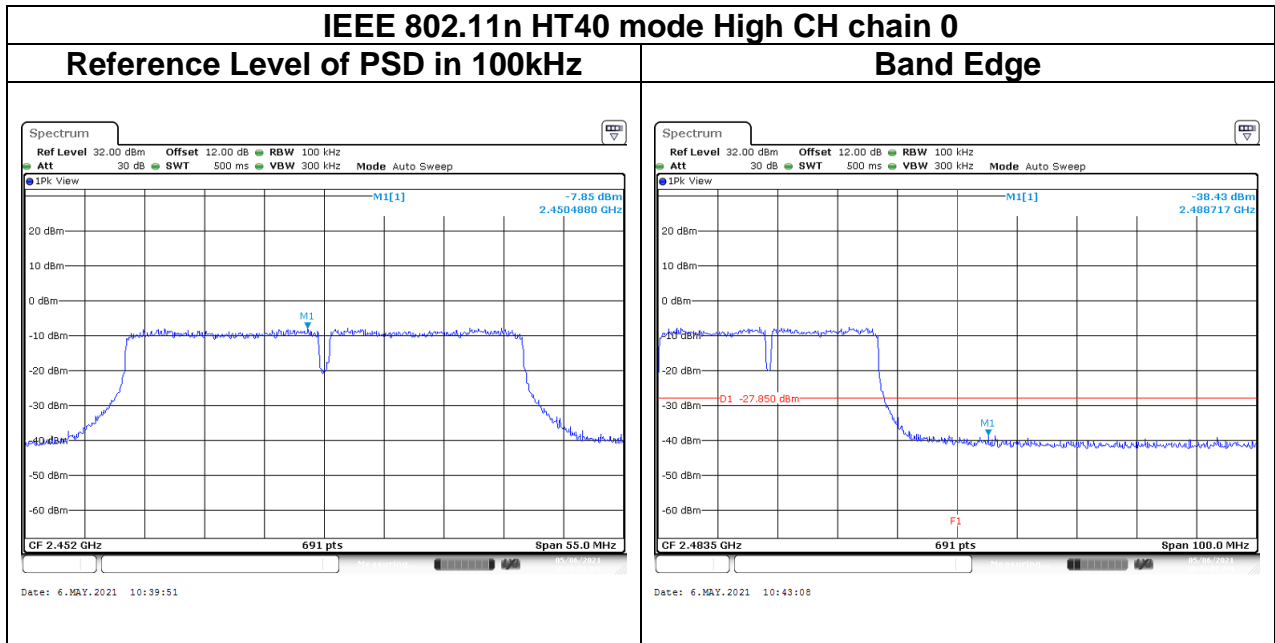

Report No.: T210324W02-RP1

4.6 RADIATION BANDEGE AND SPURIOUS EMISSION

4.6.1 Test Limit

FCC according to §15.247(d), §15.209 and §15.205,

In any 100 kHz bandwidth outside the authorized frequency band, all harmonic and spurious must be least 20 dB below the highest emission level with the authorized frequency band. Radiation emission which fall in the restricted bands must also follow the FCC section 15.209 as below limit in table.

Below 30 MHz

Frequency	Field Strength (microvolts/m)	Magnetic H-Field (microamperes/m)	Measurement Distance (metres)
9-490 kHz	2,400/F (F in kHz)	2,400/F (F in kHz)	300
490-1,705 kHz	24,000/F (F in kHz)	24,000/F (F in kHz)	30
1.705-30 MHz	30	N/A	30

Above 30 MHz

Frequency	Field Strength (microvolts/m)	Measurement Distance (metres)
30-88	100	3
88-216	150	3
216-960	200	3
Above 960	500	3

Report No.: T210324W02-RP1

4.6.2 Test Procedure

Test method Refer as ANSI C63.10:2013.

1. The EUT is placed on a turntable, Above 1 GHz is 1.5m and below 1 GHz is 0.8m above ground plane. The EUT Configured un accordance with ANSI C63.10: 2013, and the EUT set in a continuous mode.

2. The turntable shall be rotated for 360 degrees to determine the position of maximum emission level. And EUT is set 3m away from the receiving antenna, which is scanned from 1m to 4m above the ground plane to find out the highest emissions. Measurement are made polarized in both the vertical and the horizontal positions with antenna.

3. Span shall wide enough to full capture the emission measured. The SA from 9kHz to 26.5GHz set to the low, Mid and High channels with the EUT transmit.

Note: No emission found between lowest internal used/generated frequency to 30MHz (9KHz~30MHz)

Remark:

Although these tests were performed other than open area test site, adequate comparison measurements were confirmed against 30 m open are test site. Therefore sufficient tests were made to demonstrate that the alternative site produces results that correlate with the ones of tests made in an open field based on KDB 414788.

4. The SA setting following :

(1) Below 1G : RBW = 100kHz, VBW \geq 3 RBW, Sweep = Auto, Detector = Peak, Trace = Max hold.

(2) Above 1G :

(2.1) For Peak measurement : RBW = 1MHz, VBW \geq 3 RBW, Sweep = Auto, Detector = Peak, Trace = Max hold.

(2.2) For Average measurement : RBW = 1MHz, VBW

·If Duty Cycle \geq 98%, VBW=10Hz.

·If Duty Cycle < 98%, VBW=1/T.

Report No.: T210324W02-RP1

4.6.3 Test Setup

9kHz ~ 30MHz

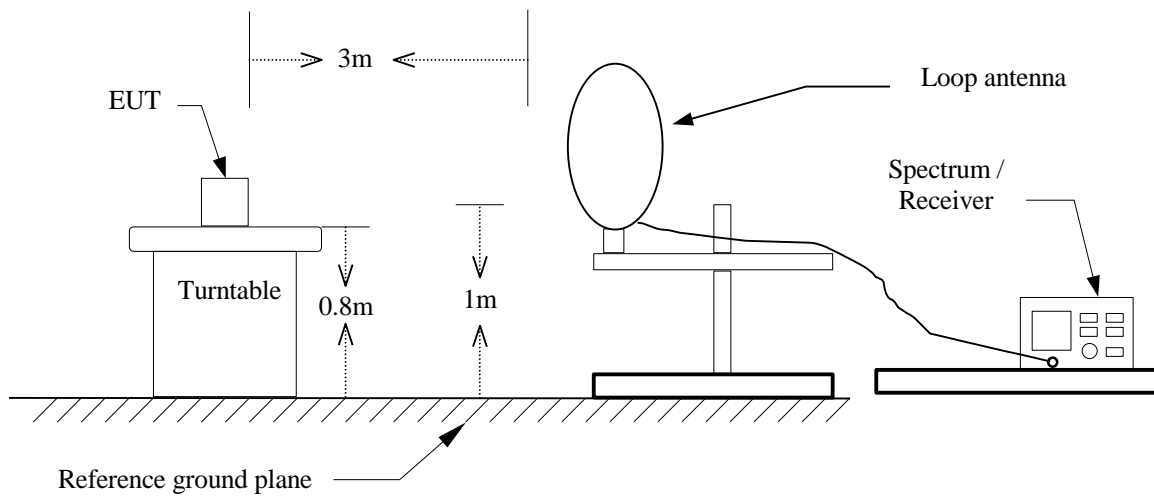

30MHz ~ 1GHz

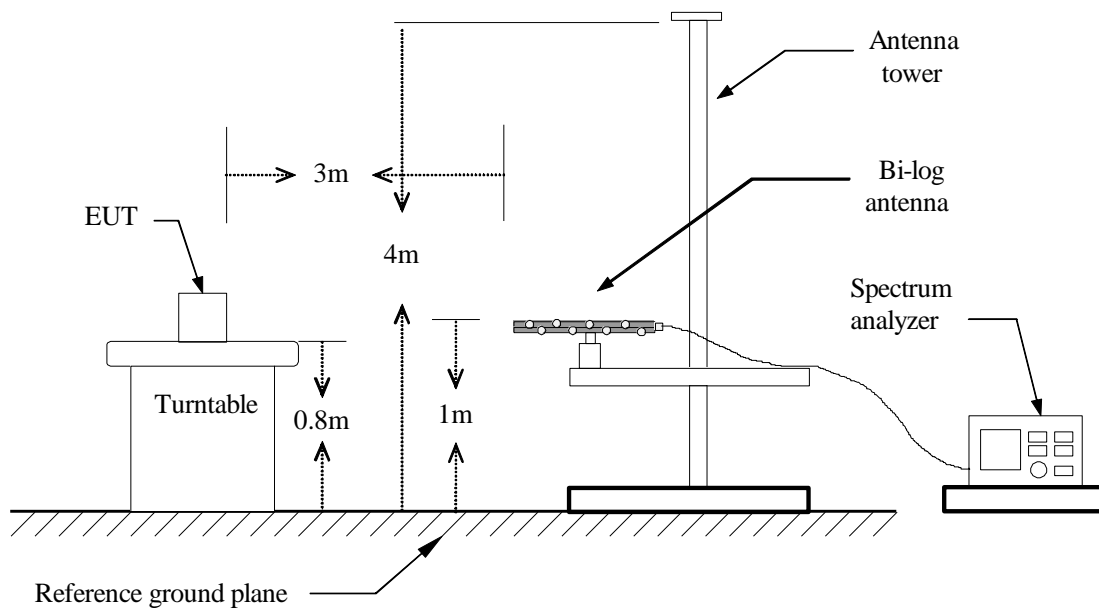

Above 1 GHz

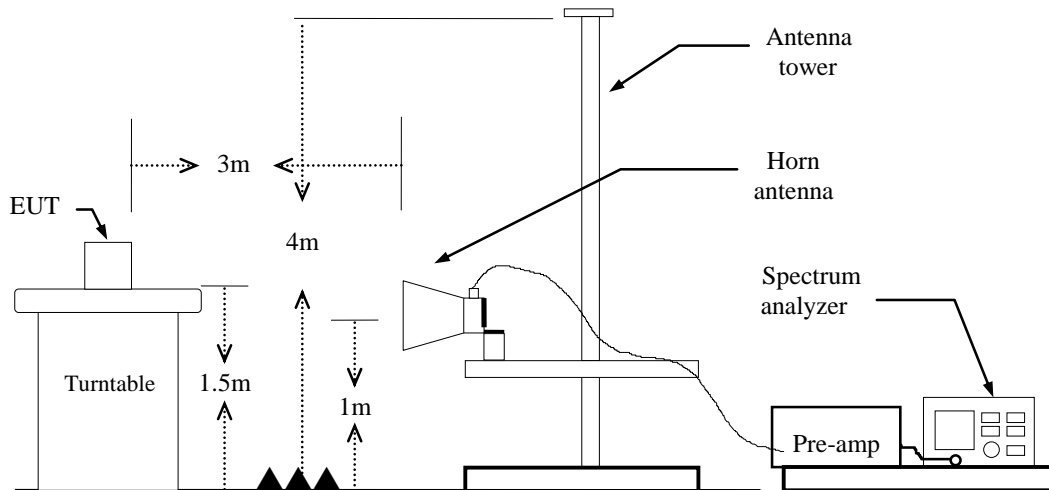

Report No.: T210324W02-RP1

4.6.4 Test Result

Band Edge Test Data

Test Mode	IEEE 802.11b Low CH 2412MHz	Temp/Hum	23.6(°C)/ 64%RH
Test Item	Band Edge	Test Date	May 6, 2021
Polarize	Vertical	Test Engineer	Ray Li
Detector	Peak / Average		

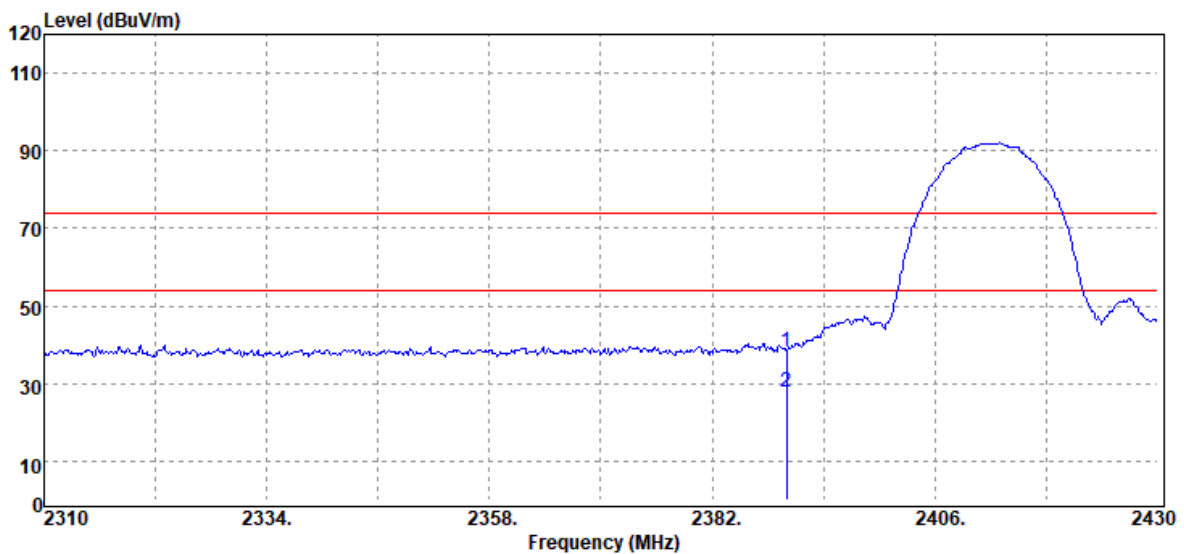

Frequency (MHz)	Detector Mode (PK/QP/AV)	Spectrum Reading Level (dBμV)	Factor (dB)	Actual FS (dBμV/m)	Limit @3m (dBμV/m)	Margin (dB)
2390.00	Peak	47.79	-9.60	38.19	74.00	-35.81
2390.00	Average	37.51	-9.60	27.91	54.00	-26.09

Report No.: T210324W02-RP1

Test Mode	IEEE 802.11b Low CH 2412MHz	Temp/Hum	23.6(°C)/ 64%RH
Test Item	Band Edge	Test Date	May 6, 2021
Polarize	Horizontal	Test Engineer	Ray Li
Detector	Peak / Average		

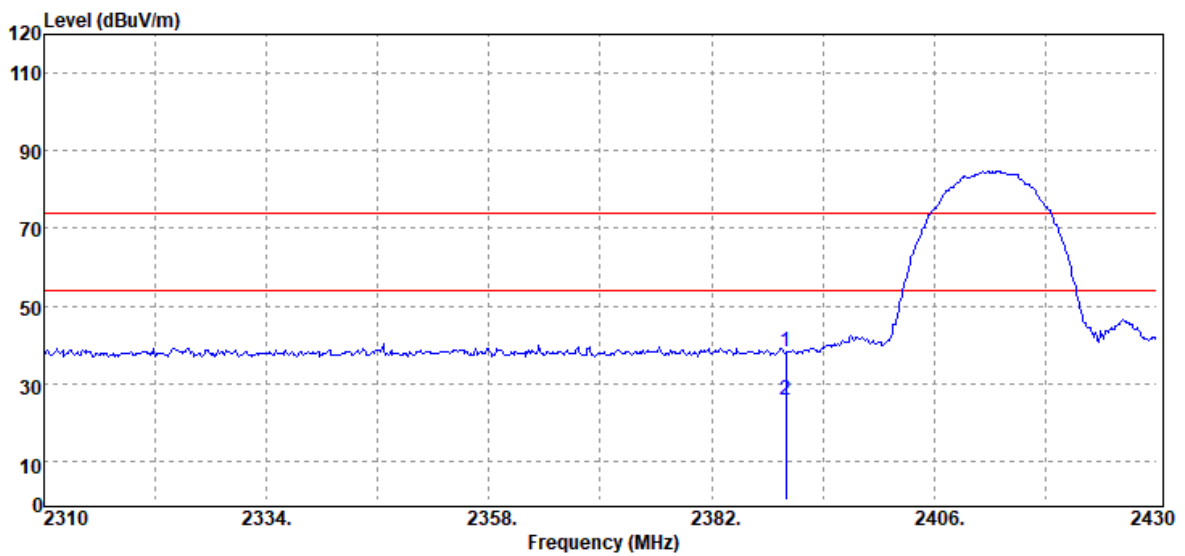

Frequency (MHz)	Detector Mode (PK/QP/AV)	Spectrum Reading Level (dB μ V)	Factor (dB)	Actual FS (dB μ V/m)	Limit @3m (dB μ V/m)	Margin (dB)
2390.00	Peak	47.65	-9.60	38.05	74.00	-35.95
2390.00	Average	35.25	-9.60	25.65	54.00	-28.35

Report No.: T210324W02-RP1

Test Mode	IEEE 802.11b High CH 2462MHz	Temp/Hum	23.6(°C)/ 64%RH
Test Item	Band Edge	Test Date	May 6, 2021
Polarize	Vertical	Test Engineer	Ray Li
Detector	Peak / Average		

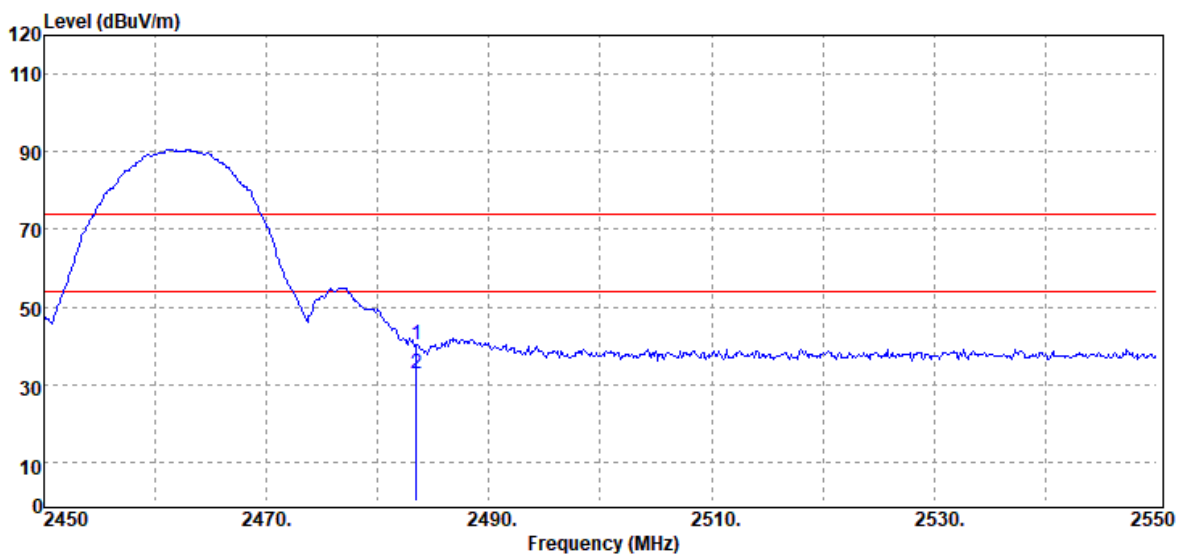

Frequency (MHz)	Detector Mode (PK/QP/AV)	Spectrum Reading Level (dBμV)	Factor (dB)	Actual FS (dBμV/m)	Limit @3m (dBμV/m)	Margin (dB)
2483.50	Peak	49.43	-9.18	40.25	74.00	-33.75
2483.50	Average	41.80	-9.18	32.62	54.00	-21.38

Report No.: T210324W02-RP1

Test Mode	IEEE 802.11b High CH 2462MHz	Temp/Hum	23.6(°C)/ 64%RH
Test Item	Band Edge	Test Date	May 6, 2021
Polarize	Horizontal	Test Engineer	Ray Li
Detector	Peak / Average		

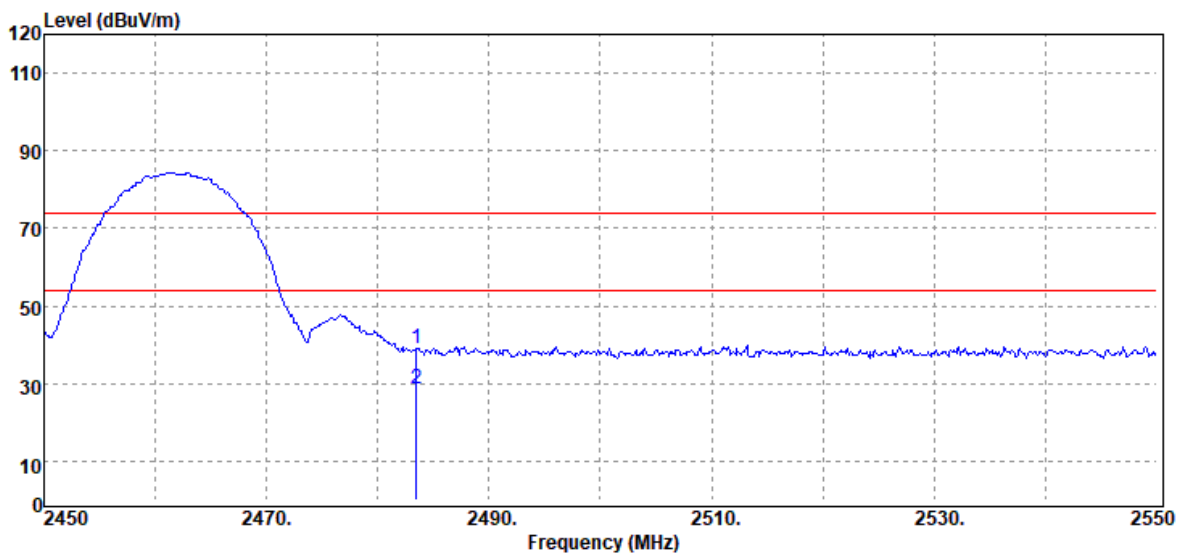

Frequency (MHz)	Detector Mode (PK/QP/AV)	Spectrum Reading Level (dBμV)	Factor (dB)	Actual FS (dBμV/m)	Limit @3m (dBμV/m)	Margin (dB)
2483.50	Peak	48.25	-9.18	39.07	74.00	-34.93
2483.50	Average	37.66	-9.18	28.48	54.00	-25.52

Report No.: T210324W02-RP1

Test Mode	IEEE 802.11g Low CH 2412MHz	Temp/Hum	23.6(°C)/ 64%RH
Test Item	Band Edge	Test Date	May 6, 2021
Polarize	Vertical	Test Engineer	Ray Li
Detector	Peak / Average		

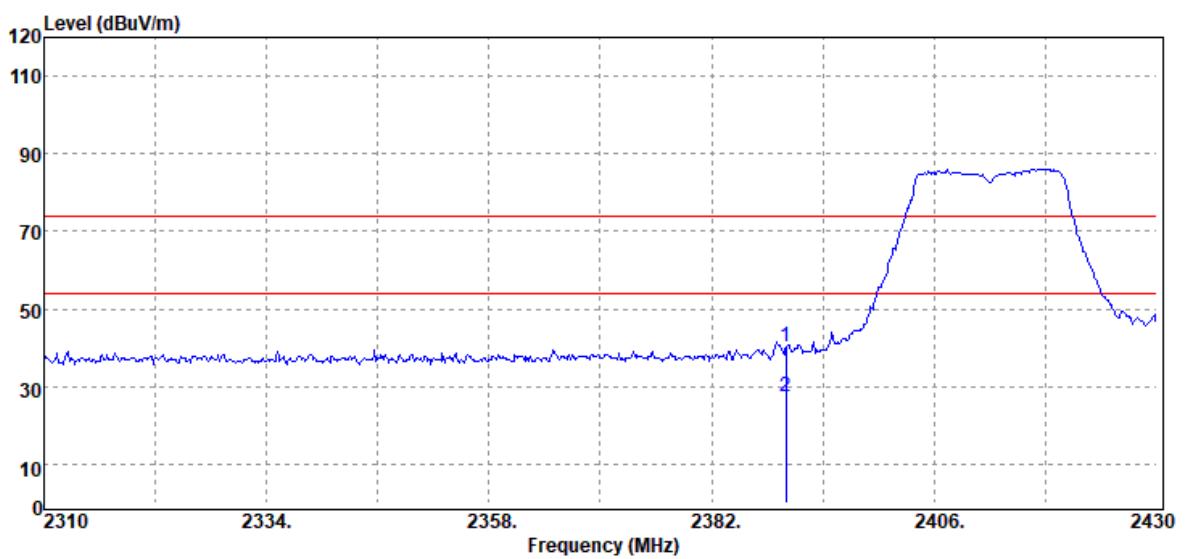

Frequency (MHz)	Detector Mode (PK/QP/AV)	Spectrum Reading Level (dB μ V)	Factor (dB)	Actual FS (dB μ V/m)	Limit @3m (dB μ V/m)	Margin (dB)
2390.00	Peak	49.68	-9.60	40.08	74.00	-33.92
2390.00	Average	37.08	-9.60	27.48	54.00	-26.52

Report No.: T210324W02-RP1

Test Mode	IEEE 802.11g Low CH 2412MHz	Temp/Hum	23.6(°C)/ 64%RH
Test Item	Band Edge	Test Date	May 6, 2021
Polarize	Horizontal	Test Engineer	Ray Li
Detector	Peak / Average		

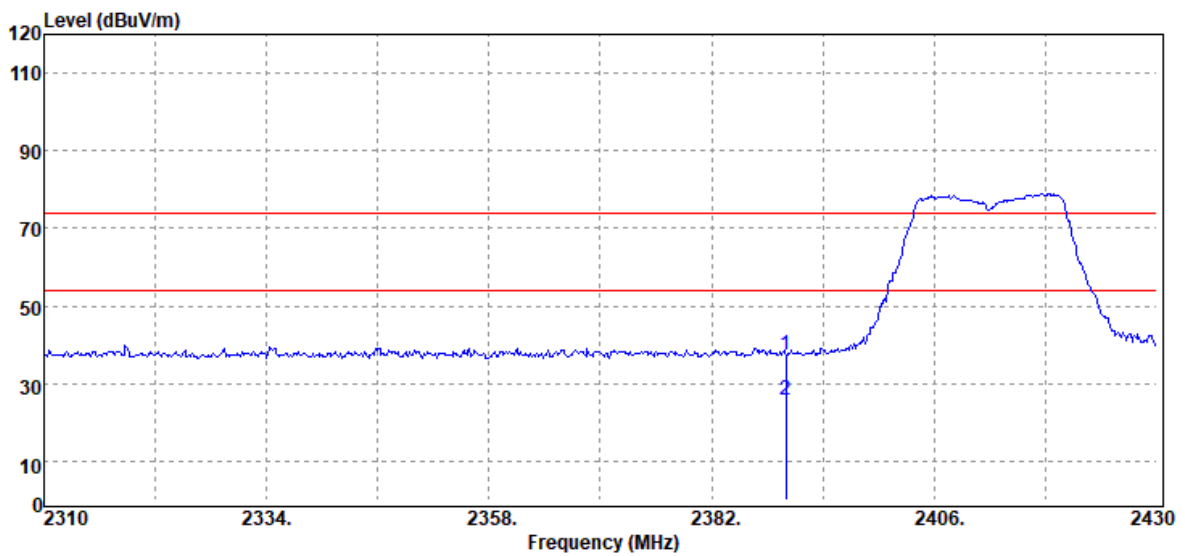

Frequency (MHz)	Detector Mode (PK/QP/AV)	Spectrum Reading Level (dBµV)	Factor (dB)	Actual FS (dBµV/m)	Limit @3m (dBµV/m)	Margin (dB)
2390.00	Peak	46.94	-9.60	37.34	74.00	-36.66
2390.00	Average	35.50	-9.60	25.90	54.00	-28.10

Report No.: T210324W02-RP1

Test Mode	IEEE 802.11g High CH 2462MHz	Temp/Hum	23.6(°C)/ 64%RH
Test Item	Band Edge	Test Date	May 6, 2021
Polarize	Vertical	Test Engineer	Ray Li
Detector	Peak / Average		

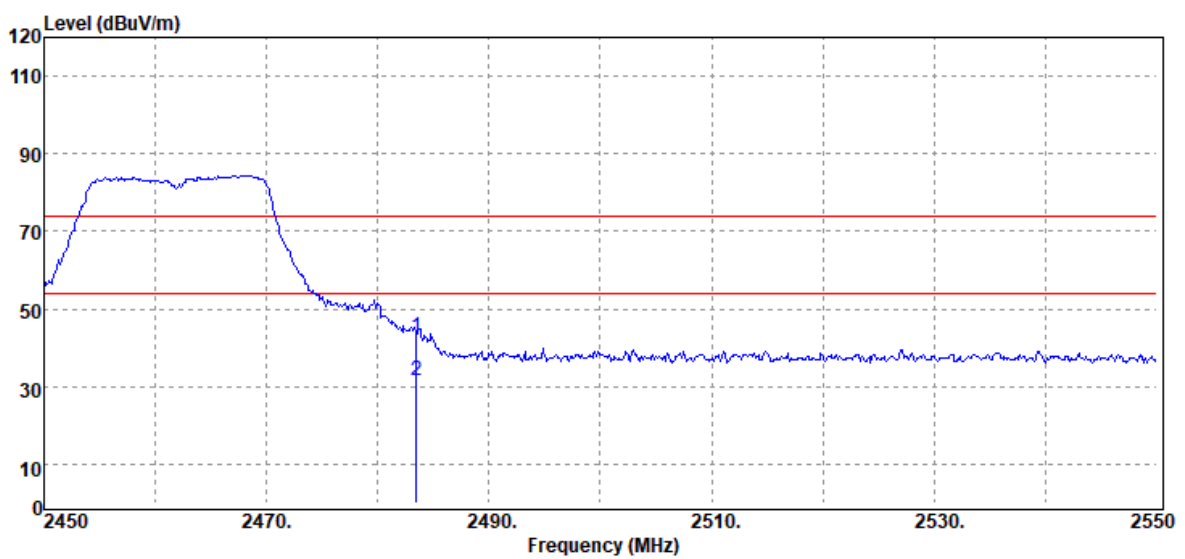

Frequency (MHz)	Detector Mode (PK/QP/AV)	Spectrum Reading Level (dBμV)	Factor (dB)	Actual FS (dBμV/m)	Limit @3m (dBμV/m)	Margin (dB)
2483.50	Peak	52.13	-9.18	42.95	74.00	-31.05
2483.50	Average	40.57	-9.18	31.39	54.00	-22.61

Report No.: T210324W02-RP1

Test Mode	IEEE 802.11g High CH 2462MHz	Temp/Hum	23.6(°C)/ 64%RH
Test Item	Band Edge	Test Date	May 6, 2021
Polarize	Horizontal	Test Engineer	Ray Li
Detector	Peak / Average		

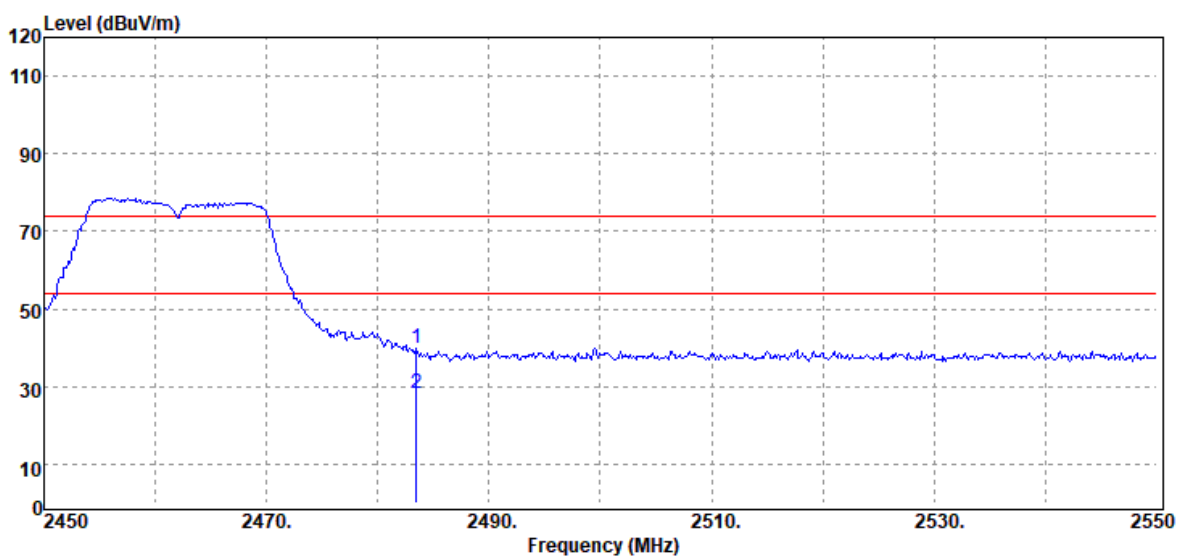

Frequency (MHz)	Detector Mode (PK/QP/AV)	Spectrum Reading Level (dBµV)	Factor (dB)	Actual FS (dBµV/m)	Limit @3m (dBµV/m)	Margin (dB)
2483.50	Peak	49.23	-9.18	40.05	74.00	-33.95
2483.50	Average	37.23	-9.18	28.05	54.00	-25.95

Report No.: T210324W02-RP1

Test Mode	IEEE 802.11n HT20 Low CH 2412MHz	Temp/Hum	23.6(°C)/ 64%RH
Test Item	Band Edge	Test Date	May 6, 2021
Polarize	Vertical	Test Engineer	Ray Li
Detector	Peak / Average		

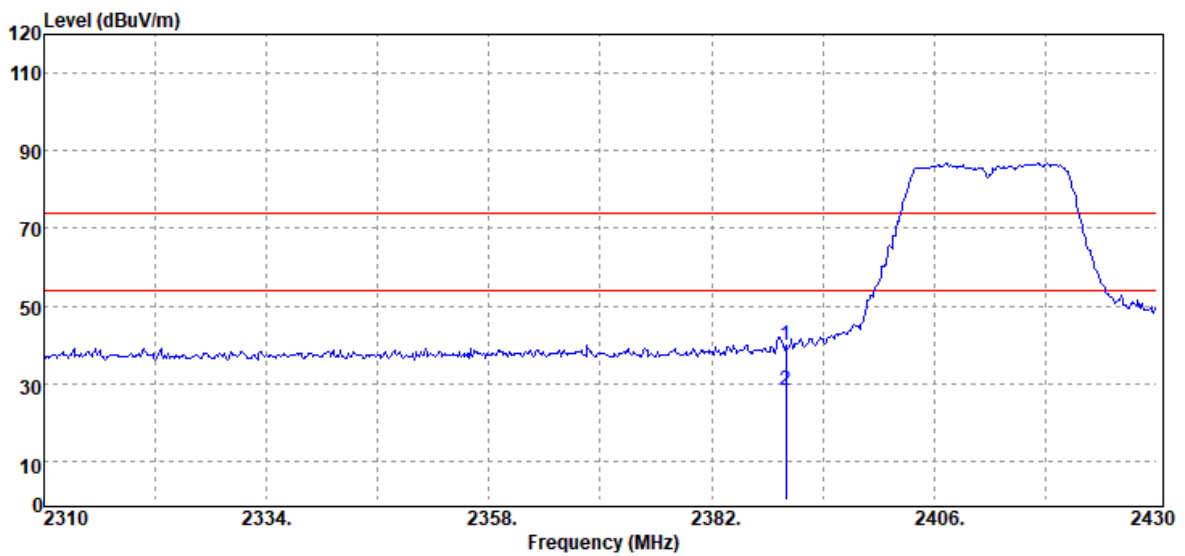

Frequency (MHz)	Detector Mode (PK/QP/AV)	Spectrum Reading Level (dB μ V)	Factor (dB)	Actual FS (dB μ V/m)	Limit @3m (dB μ V/m)	Margin (dB)
2390.00	Peak	49.44	-9.60	39.84	74.00	-34.16
2390.00	Average	37.65	-9.60	28.05	54.00	-25.95

Report No.: T210324W02-RP1

Test Mode	IEEE 802.11 n20 Low CH 2412MHz	Temp/Hum	23.6(°C)/ 64%RH
Test Item	Band Edge	Test Date	May 6, 2021
Polarize	Horizontal	Test Engineer	Ray Li
Detector	Peak / Average		

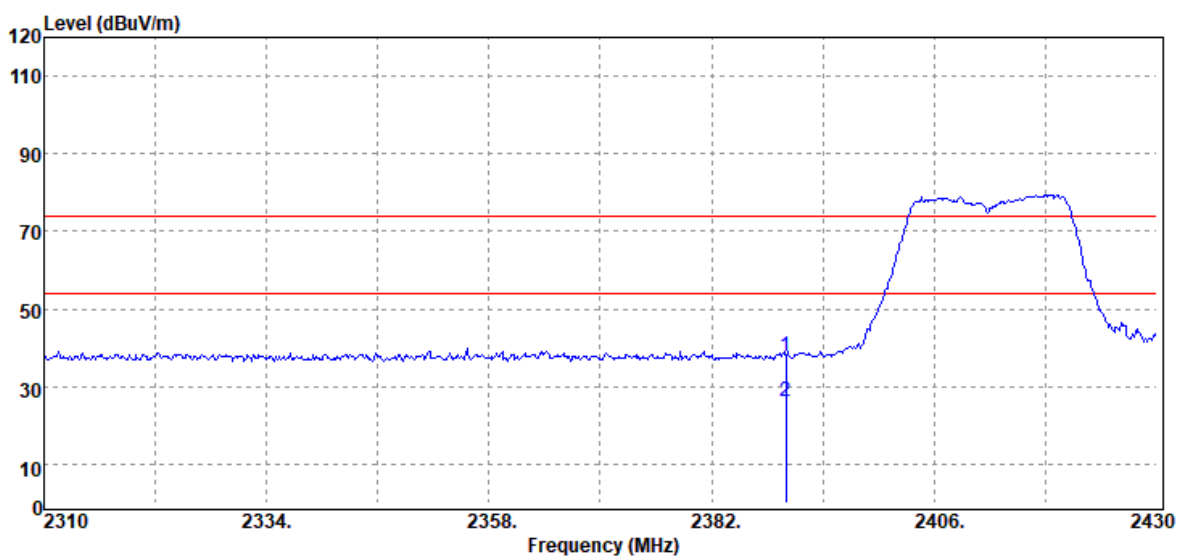

Frequency (MHz)	Detector Mode (PK/QP/AV)	Spectrum Reading Level (dBµV)	Factor (dB)	Actual FS (dBµV/m)	Limit @3m (dBµV/m)	Margin (dB)
2390.00	Peak	47.52	-9.60	37.92	74.00	-36.08
2390.00	Average	35.62	-9.60	26.02	54.00	-27.98

Report No.: T210324W02-RP1

Test Mode	IEEE 802.11n HT20 High CH 2462MHz	Temp/Hum	23.6(°C)/ 64%RH
Test Item	Band Edge	Test Date	May 6, 2021
Polarize	Vertical	Test Engineer	Ray Li
Detector	Peak / Average		

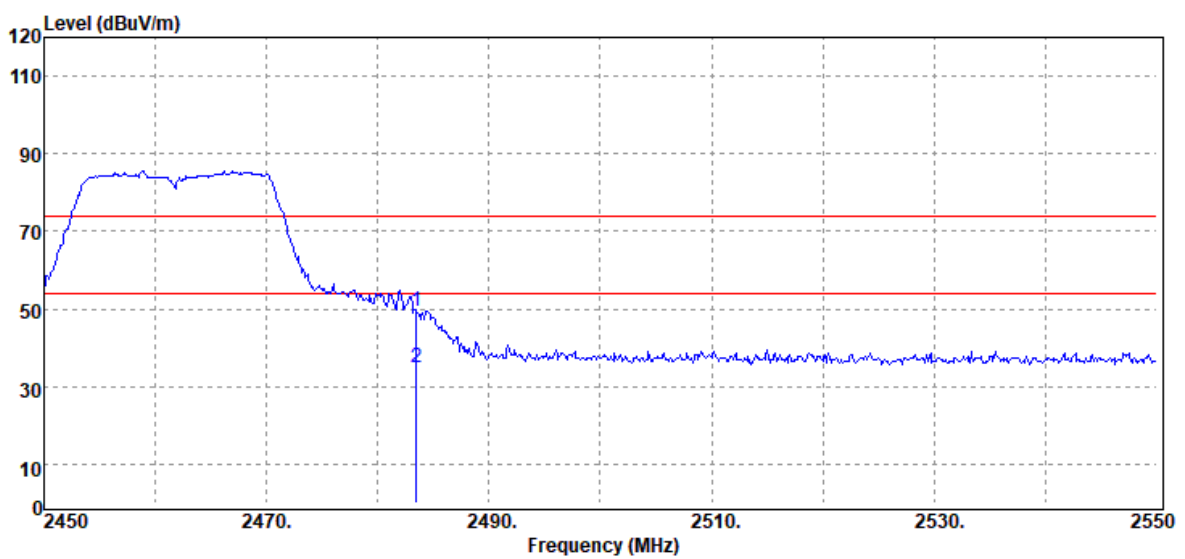

Frequency (MHz)	Detector Mode (PK/QP/AV)	Spectrum Reading Level (dBμV)	Factor (dB)	Actual FS (dBμV/m)	Limit @3m (dBμV/m)	Margin (dB)
2483.50	Peak	58.72	-9.18	49.54	74.00	-24.46
2483.50	Average	44.12	-9.18	34.94	54.00	-19.06

Report No.: T210324W02-RP1

Test Mode	IEEE 802.11n20 High CH 2462MHz	Temp/Hum	23.6(°C)/ 64%RH
Test Item	Band Edge	Test Date	May 6, 2021
Polarize	Horizontal	Test Engineer	Ray Li
Detector	Peak / Average		

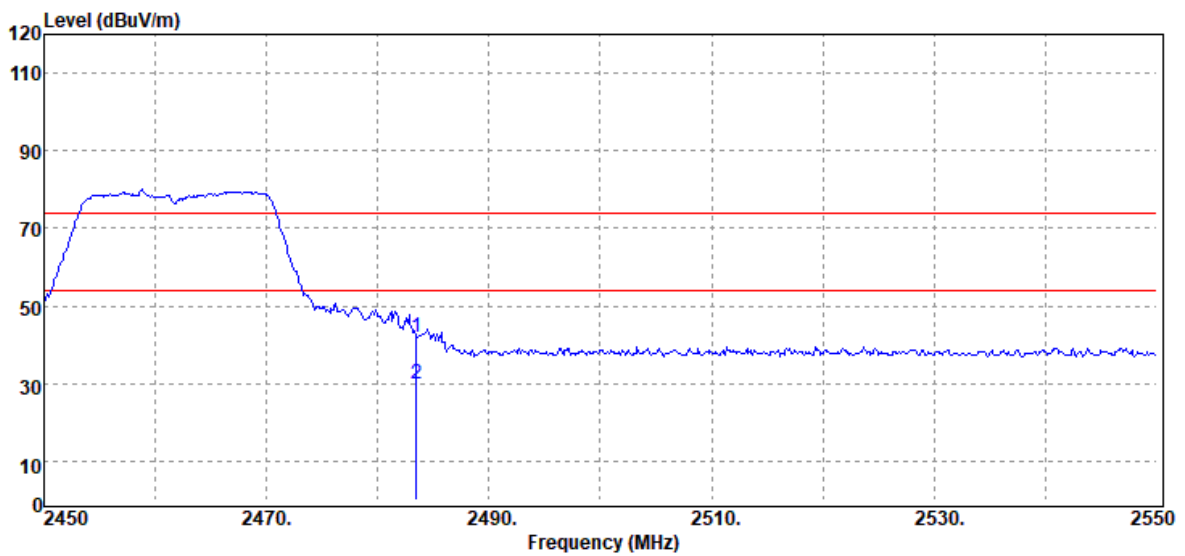

Frequency (MHz)	Detector Mode (PK/QP/AV)	Spectrum Reading Level (dBµV)	Factor (dB)	Actual FS (dBµV/m)	Limit @3m (dBµV/m)	Margin (dB)
2483.50	Peak	51.27	-9.18	42.09	74.00	-31.91
2483.50	Average	38.87	-9.18	29.69	54.00	-24.31

Report No.: T210324W02-RP1

Test Mode	IEEE 802.11n HT40 Low CH 2422MHz	Temp/Hum	23.6(°C)/ 64%RH
Test Item	Band Edge	Test Date	May 6, 2021
Polarize	Vertical	Test Engineer	Ray Li
Detector	Peak / Average		

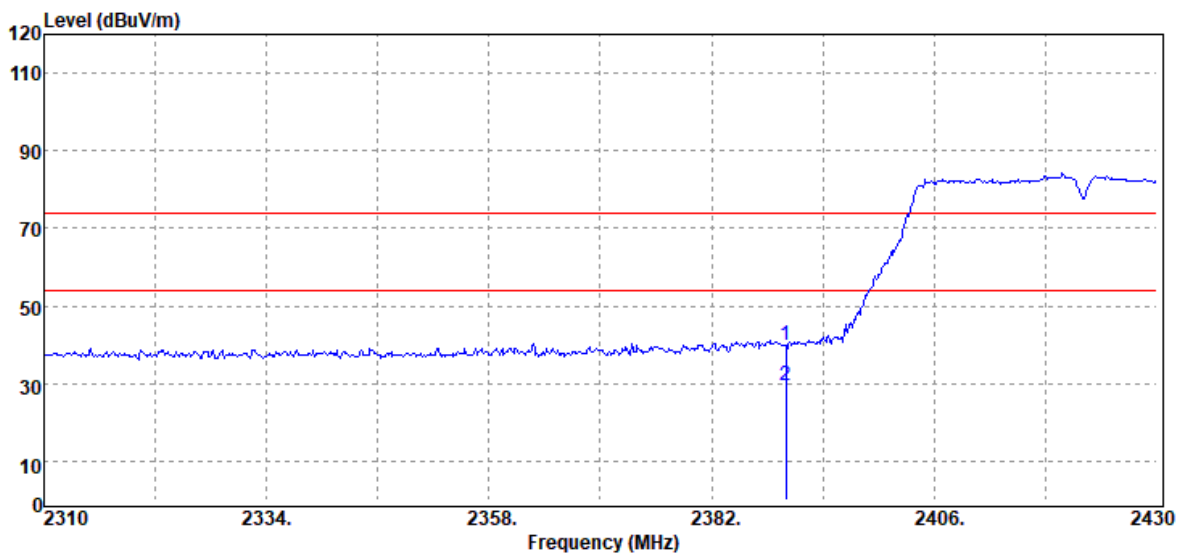

Frequency (MHz)	Detector Mode (PK/QP/AV)	Spectrum Reading Level (dBµV)	Factor (dB)	Actual FS (dBµV/m)	Limit @3m (dBµV/m)	Margin (dB)
2390.00	Peak	49.61	-9.60	40.01	74.00	-33.99
2390.00	Average	38.88	-9.60	29.28	54.00	-24.72

Report No.: T210324W02-RP1

Test Mode	IEEE 802.11 n40 Low CH 2422MHz	Temp/Hum	23.6(°C)/ 64%RH
Test Item	Band Edge	Test Date	May 6, 2021
Polarize	Horizontal	Test Engineer	Ray Li
Detector	Peak / Average		

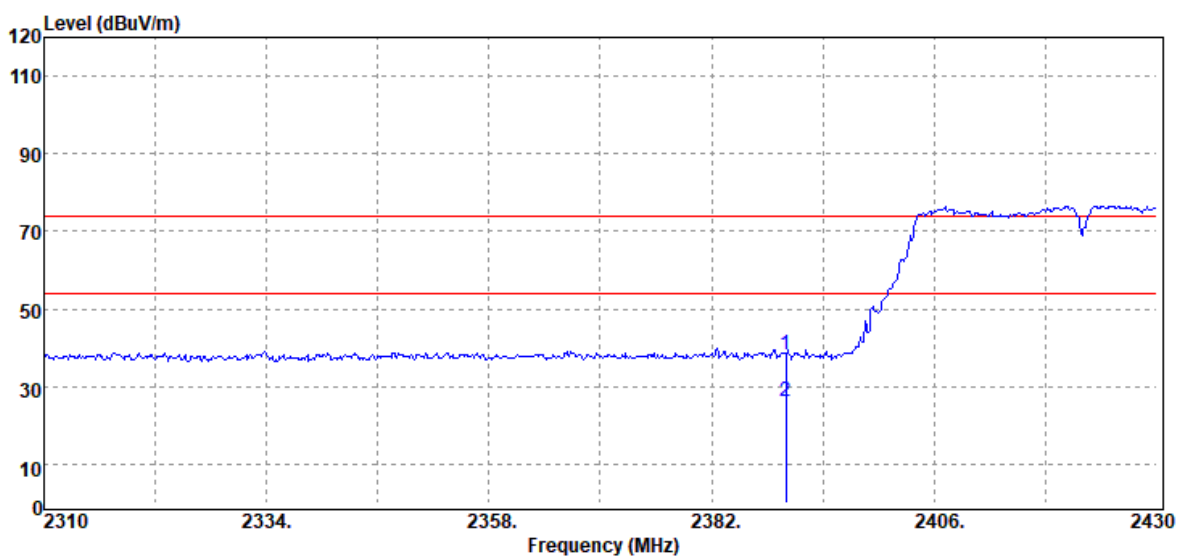

Frequency (MHz)	Detector Mode (PK/QP/AV)	Spectrum Reading Level (dBμV)	Factor (dB)	Actual FS (dBμV/m)	Limit @3m (dBμV/m)	Margin (dB)
2390.00	Peak	47.79	-9.60	38.19	74.00	-35.81
2390.00	Average	35.95	-9.60	26.35	54.00	-27.65

Report No.: T210324W02-RP1

Test Mode	IEEE 802.11n HT40 High CH 2452MHz	Temp/Hum	23.6(°C)/ 64%RH
Test Item	Band Edge	Test Date	May 6, 2021
Polarize	Vertical	Test Engineer	Ray Li
Detector	Peak / Average		

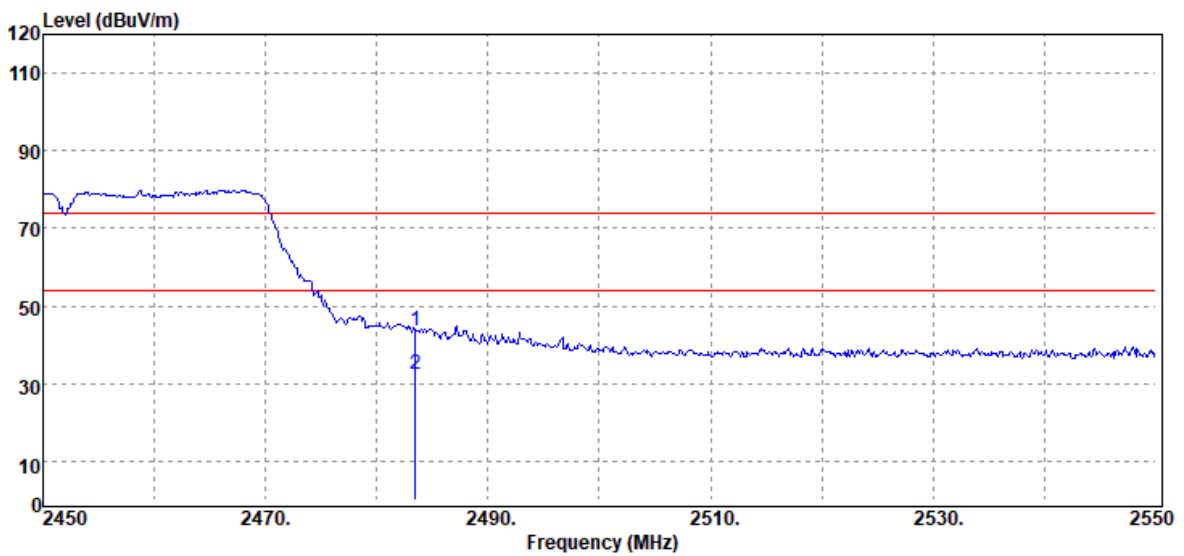

Frequency (MHz)	Detector Mode (PK/QP/AV)	Spectrum Reading Level (dBμV)	Factor (dB)	Actual FS (dBμV/m)	Limit @3m (dBμV/m)	Margin (dB)
2483.50	Peak	52.91	-9.18	43.73	74.00	-30.27
2483.50	Average	41.73	-9.18	32.55	54.00	-21.45

Report No.: T210324W02-RP1

Test Mode	IEEE 802.11n40 High CH 2452MHz	Temp/Hum	23.6(°C)/ 64%RH
Test Item	Band Edge	Test Date	May 6, 2021
Polarize	Horizontal	Test Engineer	Ray Li
Detector	Peak / Average		

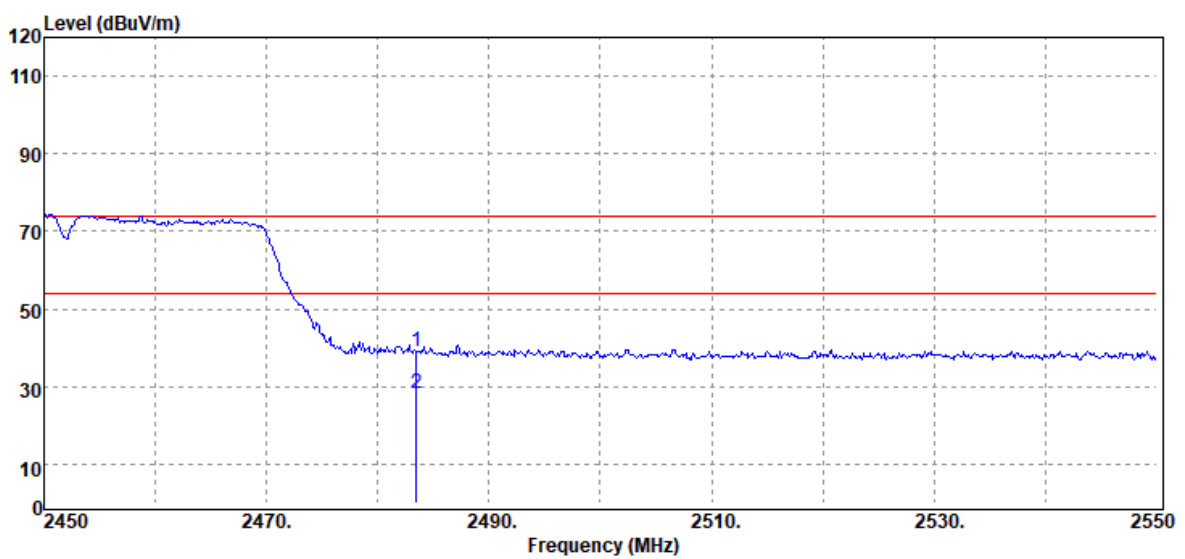

Frequency (MHz)	Detector Mode (PK/QP/AV)	Spectrum Reading Level (dBµV)	Factor (dB)	Actual FS (dBµV/m)	Limit @3m (dBµV/m)	Margin (dB)
2483.50	Peak	48.03	-9.18	38.85	74.00	-35.15
2483.50	Average	37.34	-9.18	28.16	54.00	-25.84

Report No.: T210324W02-RP1

Below 1G Test Data

Test Mode	Mode 1	Temp/Hum	23.6(°C)/ 64%RH
Test Item	30MHz-1GHz	Test Date	May 6, 2021
Polarize	Vertical	Test Engineer	Ray Li
Detector	Peak	Test Voltage	

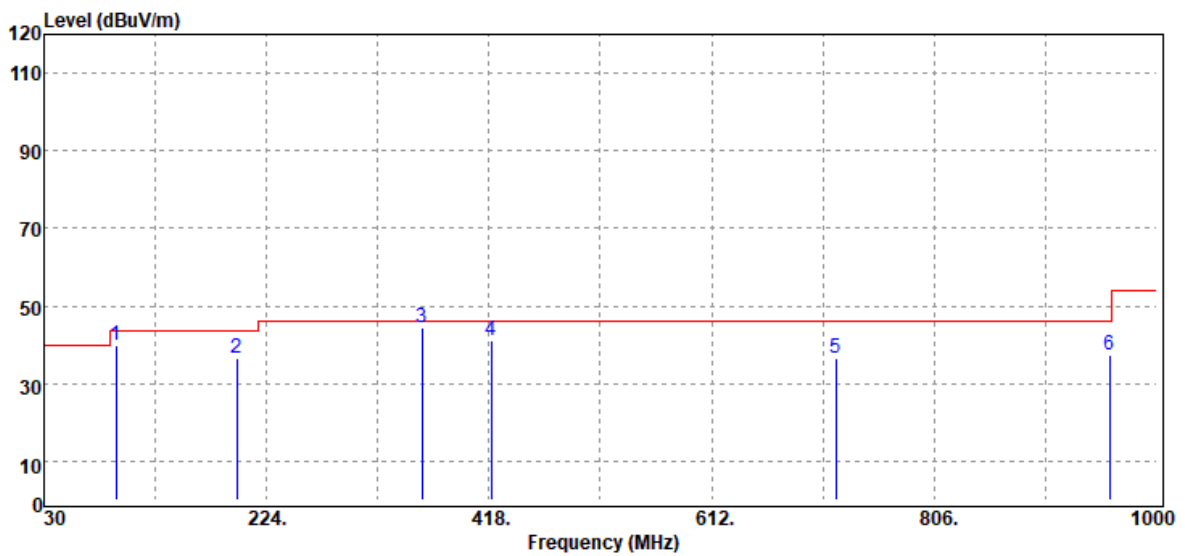

Freq. (MHz)	Detector Mode (PK/QP/AV)	Spectrum Reading Level (dBμV)	Factor (dB)	Actual FS (dBμV/m)	Limit @3m (dBμV/m)	Margin (dB)
93.05	Peak	54.49	-14.52	39.97	43.50	-3.53
197.81	Peak	45.91	-9.26	36.65	43.50	-6.85
359.80	Peak	50.86	-6.59	44.27	46.00	-1.73
419.94	Peak	45.52	-4.42	41.10	46.00	-4.90
720.64	Peak	35.77	0.68	36.45	46.00	-9.55
959.26	Peak	32.97	4.57	37.54	46.00	-8.46

Note: No emission found between lowest internal used/generated frequency to 30MHz(9KHz~30MHz)

Report No.: T210324W02-RP1

Test Mode	Mode 1	Temp/Hum	23.6(°C)/ 64%RH
Test Item	30MHz-1GHz	Test Date	May 6, 2021
Polarize	Horizontal	Test Engineer	Ray Li
Detector	Peak	Test Voltage	

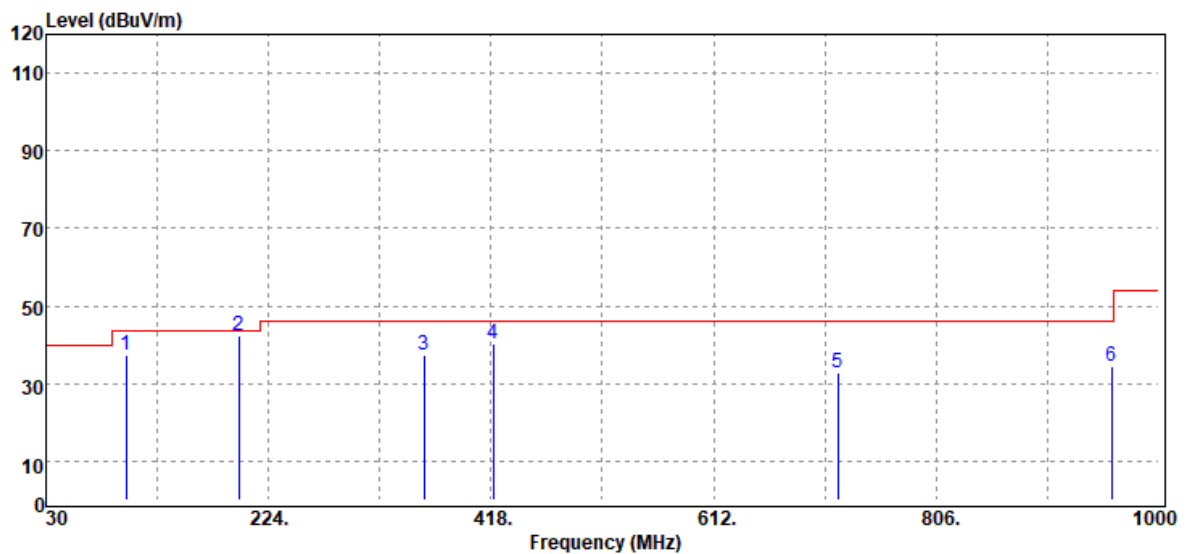

Freq. (MHz)	Detector Mode (PK/QP/AV)	Spectrum Reading Level (dBμV)	Factor (dB)	Actual FS (dBμV/m)	Limit @3m (dBμV/m)	Margin (dB)
99.84	Peak	49.93	-12.55	37.38	43.50	-6.12
197.81	Peak	51.57	-9.26	42.31	43.50	-1.19
359.80	Peak	44.00	-6.59	37.41	46.00	-8.59
419.94	Peak	44.75	-4.42	40.33	46.00	-5.67
720.64	Peak	32.24	0.68	32.92	46.00	-13.08
959.26	Peak	29.89	4.57	34.46	46.00	-11.54

Note: No emission found between lowest internal used/generated frequency to 30MHz(9KHz~30MHz)

Report No.: T210324W02-RP1

Above 1G Test Data

Test Mode	IEEE 802.11b Low CH	Temp/Hum	23.6(°C)/ 64%RH
Test Item	Harmonic	Test Date	May 6, 2021
Polarize	Vertical	Test Engineer	Ray Li
Detector	Peak		

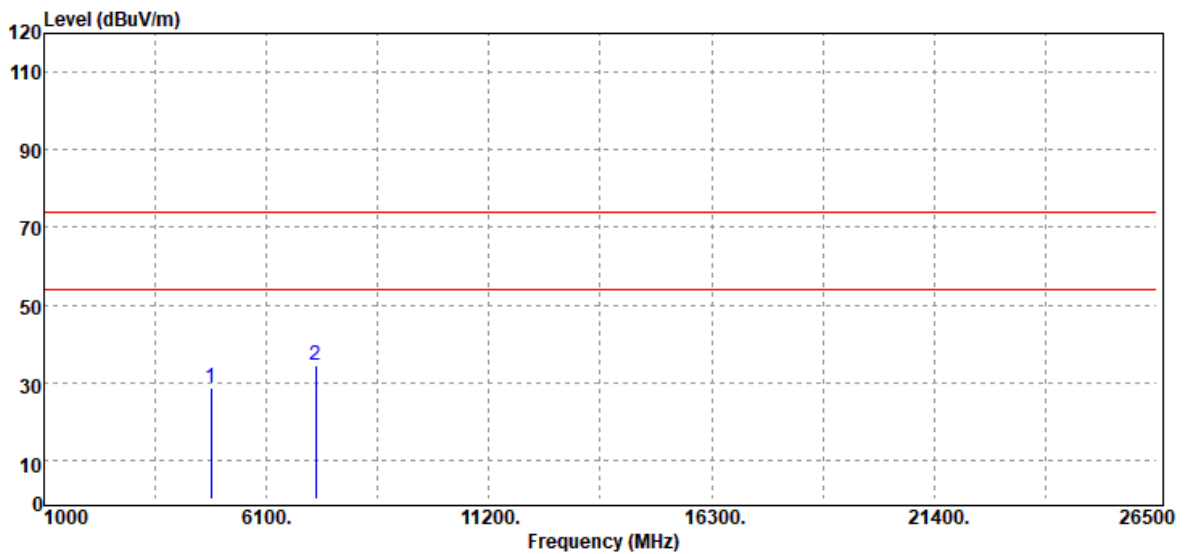

Freq. (MHz)	Detector Mode (PK/QP/AV)	Spectrum Reading Level (dBµV)	Factor (dB)	Actual FS (dBµV/m)	Limit @3m (dBµV/m)	Margin (dB)
4824.00	Peak	34.58	-6.11	28.47	74.00	-45.53
7236.00	Peak	35.29	-0.88	34.41	74.00	-39.59
N/A						

Remark:

1. Measuring frequencies from 1 GHz to the 10th harmonic of highest fundamental frequency.
2. For above 1GHz,the EUT peak value was under average limit, therefore the Average value compliance with the average limit

Report No.: T210324W02-RP1

Test Mode	IEEE 802.11b Low CH	Temp/Hum	23.6(°C)/ 64%RH
Test Item	Harmonic	Test Date	May 6, 2021
Polarize	Horizontal	Test Engineer	Ray Li
Detector	Peak		

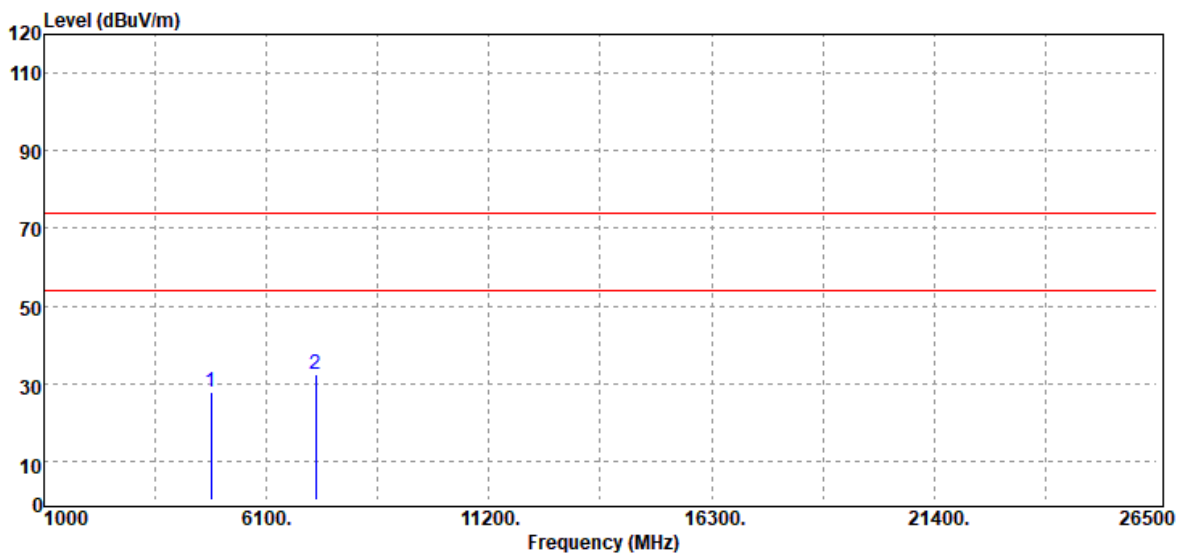

Freq. (MHz)	Detector Mode (PK/QP/AV)	Spectrum Reading Level (dBµV)	Factor (dB)	Actual FS (dBµV/m)	Limit @3m (dBµV/m)	Margin (dB)
4824.00	Peak	33.78	-6.11	27.67	74.00	-46.33
7236.00	Peak	33.29	-0.88	32.41	74.00	-41.59
N/A						

Remark:

1. Measuring frequencies from 1 GHz to the 10th harmonic of highest fundamental frequency.
2. For above 1GHz, the EUT peak value was under average limit, therefore the Average value compliance with the average limit

Report No.: T210324W02-RP1

Test Mode	IEEE 802.11b Mid CH	Temp/Hum	23.6(°C)/ 64%RH
Test Item	Harmonic	Test Date	May 6, 2021
Polarize	Vertical	Test Engineer	Ray Li
Detector	Peak		

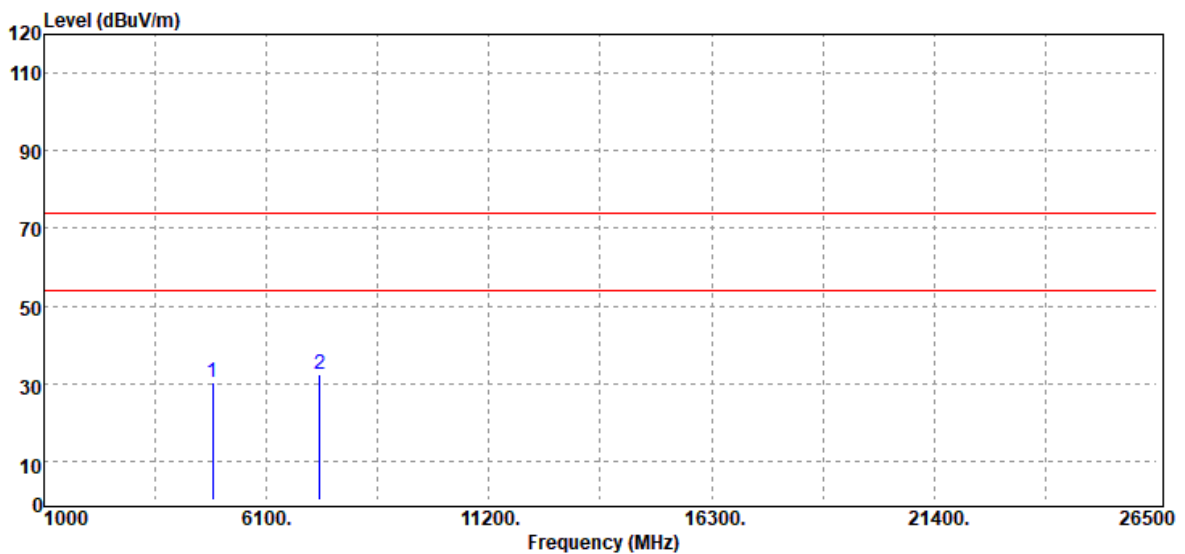

Freq. (MHz)	Detector Mode (PK/QP/AV)	Spectrum Reading Level (dBµV)	Factor (dB)	Actual FS (dBµV/m)	Limit @3m (dBµV/m)	Margin (dB)
4874.00	Peak	36.42	-6.00	30.42	74.00	-43.58
7311.00	Peak	33.12	-0.92	32.20	74.00	-41.80
N/A						

Remark:

1. Measuring frequencies from 1 GHz to the 10th harmonic of highest fundamental frequency.
2. For above 1GHz, the EUT peak value was under average limit, therefore the Average value compliance with the average limit

Report No.: T210324W02-RP1

Test Mode	IEEE 802.11b Mid CH	Temp/Hum	23.6(°C)/ 64%RH
Test Item	Harmonic	Test Date	May 6, 2021
Polarize	Horizontal	Test Engineer	Ray Li
Detector	Peak		

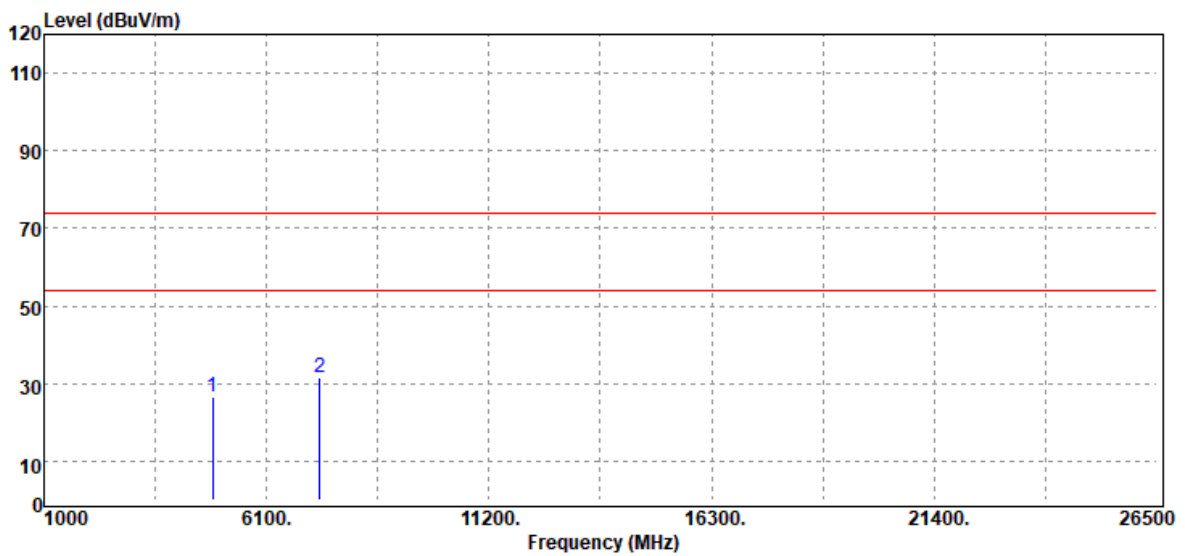

Freq. (MHz)	Detector Mode (PK/QP/AV)	Spectrum Reading Level (dBµV)	Factor (dB)	Actual FS (dBµV/m)	Limit @3m (dBµV/m)	Margin (dB)
4874.00	Peak	32.72	-6.00	26.72	74.00	-47.28
7311.00	Peak	32.31	-0.92	31.39	74.00	-42.61
N/A						

Remark:

1. Measuring frequencies from 1 GHz to the 10th harmonic of highest fundamental frequency.
2. For above 1GHz, the EUT peak value was under average limit, therefore the Average value compliance with the average limit

Report No.: T210324W02-RP1

Test Mode	IEEE 802.11b High CH	Temp/Hum	23.6(°C)/ 64%RH
Test Item	Harmonic	Test Date	May 6, 2021
Polarize	Vertical	Test Engineer	Ray Li
Detector	Peak		

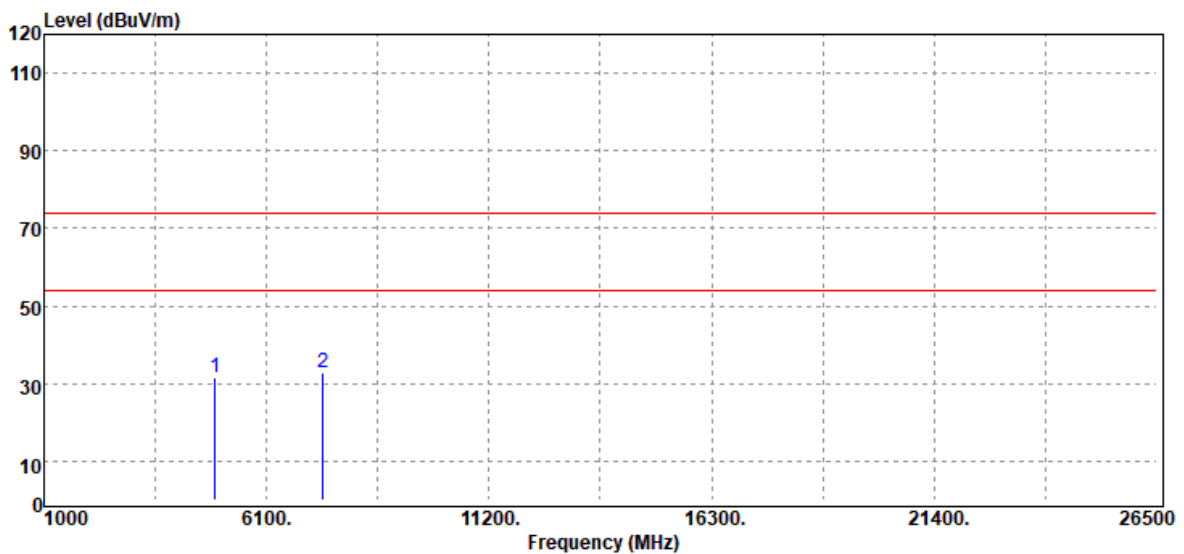

Freq. (MHz)	Detector Mode (PK/QP/AV)	Spectrum Reading Level (dB μ V)	Factor (dB)	Actual FS (dB μ V/m)	Limit @3m (dB μ V/m)	Margin (dB)
4924.00	Peak	37.29	-5.62	31.67	74.00	-42.33
7386.00	Peak	33.59	-0.68	32.91	74.00	-41.09
N/A						

Remark:

1. Measuring frequencies from 1 GHz to the 10th harmonic of highest fundamental frequency.
2. For above 1GHz, the EUT peak value was under average limit, therefore the Average value compliance with the average limit

Report No.: T210324W02-RP1

Test Mode	IEEE 802.11b High CH	Temp/Hum	23.6(°C)/ 64%RH
Test Item	Harmonic	Test Date	May 6, 2021
Polarize	Horizontal	Test Engineer	Ray Li
Detector	Peak		

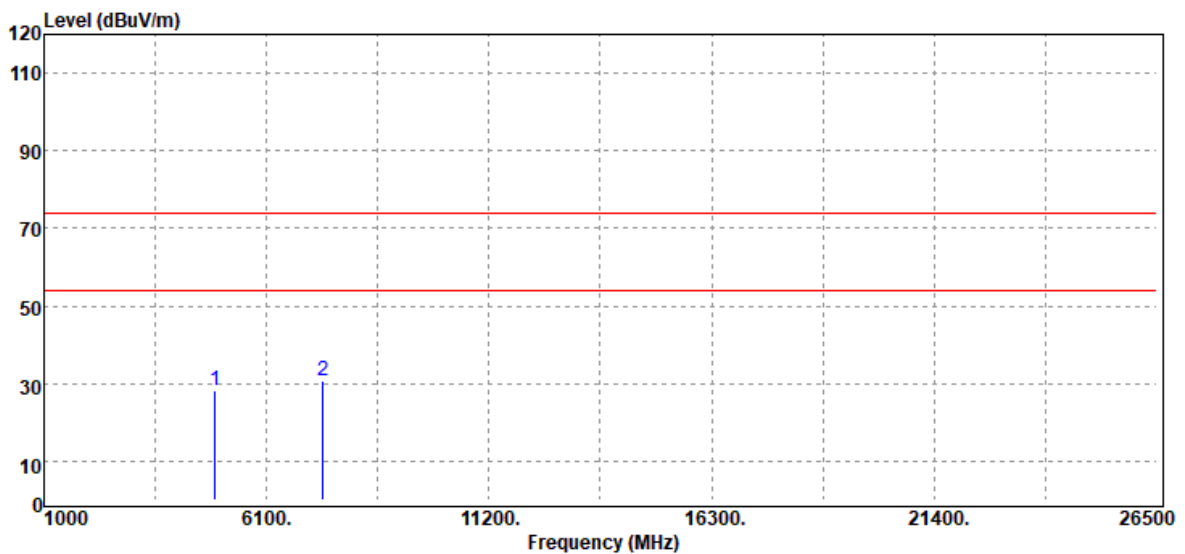

Freq. (MHz)	Detector Mode (PK/QP/AV)	Spectrum Reading Level (dBµV)	Factor (dB)	Actual FS (dBµV/m)	Limit @3m (dBµV/m)	Margin (dB)
4924.00	Peak	33.68	-5.62	28.06	74.00	-45.94
7386.00	Peak	31.31	-0.68	30.63	74.00	-43.37
N/A						

Remark:

1. Measuring frequencies from 1 GHz to the 10th harmonic of highest fundamental frequency.
2. For above 1GHz, the EUT peak value was under average limit, therefore the Average value compliance with the average limit

Report No.: T210324W02-RP1

Test Mode	IEEE 802.11g Low CH	Temp/Hum	23.6(°C)/ 64%RH
Test Item	Harmonic	Test Date	May 6, 2021
Polarize	Vertical	Test Engineer	Ray Li
Detector	Peak		

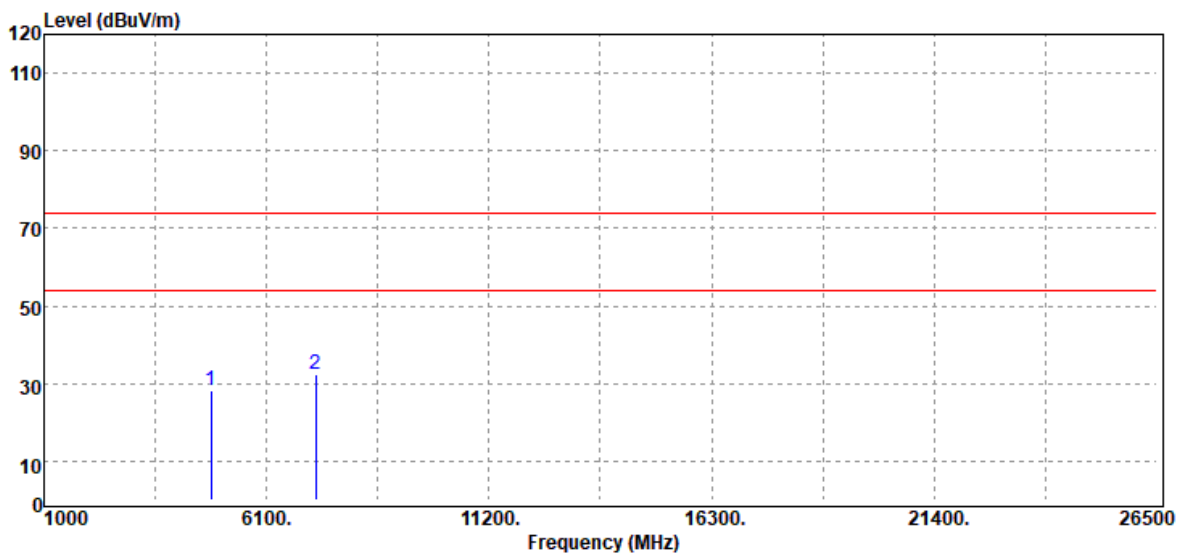

Freq. (MHz)	Detector Mode (PK/QP/AV)	Spectrum Reading Level (dBμV)	Factor (dB)	Actual FS (dBμV/m)	Limit @3m (dBμV/m)	Margin (dB)
4824.00	Peak	34.22	-6.11	28.11	74.00	-45.89
7236.00	Peak	33.32	-0.88	32.44	74.00	-41.56
N/A						

Remark:

1. Measuring frequencies from 1 GHz to the 10th harmonic of highest fundamental frequency.
2. For above 1GHz, the EUT peak value was under average limit, therefore the Average value compliance with the average limit

Report No.: T210324W02-RP1

Test Mode	IEEE 802.11g Low CH	Temp/Hum	23.6(°C)/ 64%RH
Test Item	Harmonic	Test Date	May 6, 2021
Polarize	Horizontal	Test Engineer	Ray Li
Detector	Peak		

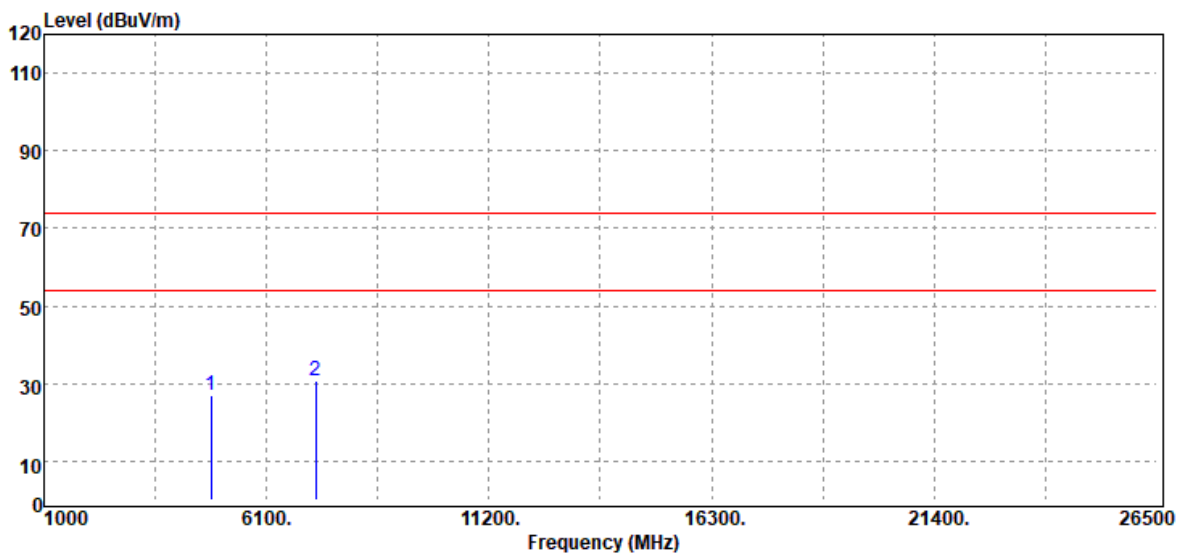

Freq. (MHz)	Detector Mode (PK/QP/AV)	Spectrum Reading Level (dBµV)	Factor (dB)	Actual FS (dBµV/m)	Limit @3m (dBµV/m)	Margin (dB)
4824.00	Peak	33.30	-6.11	27.19	74.00	-46.81
7236.00	Peak	31.74	-0.88	30.86	74.00	-43.14
N/A						

Remark:

1. Measuring frequencies from 1 GHz to the 10th harmonic of highest fundamental frequency.
2. For above 1GHz, the EUT peak value was under average limit, therefore the Average value compliance with the average limit

Report No.: T210324W02-RP1

Test Mode	IEEE 802.11g Mid CH	Temp/Hum	23.6(°C)/ 64%RH
Test Item	Harmonic	Test Date	May 6, 2021
Polarize	Vertical	Test Engineer	Ray Li
Detector	Peak / Average		

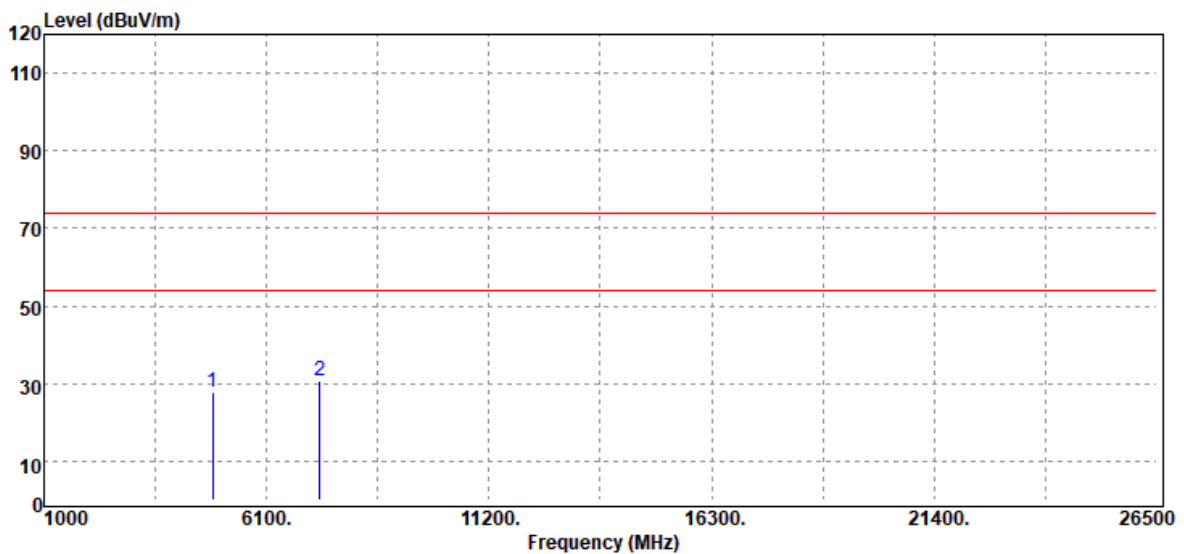

Freq. (MHz)	Detector Mode (PK/QP/AV)	Spectrum Reading Level (dBμV)	Factor (dB)	Actual FS (dBμV/m)	Limit @3m (dBμV/m)	Margin (dB)
4874.00	Peak	33.70	-6.00	27.70	74.00	-46.30
7311.00	Peak	31.64	-0.92	30.72	74.00	-43.28
N/A						

Remark:

1. Measuring frequencies from 1 GHz to the 10th harmonic of highest fundamental frequency.
2. For above 1GHz, the EUT peak value was under average limit, therefore the Average value compliance with the average limit

Report No.: T210324W02-RP1

Test Mode	IEEE 802.11g Mid CH	Temp/Hum	23.6(°C)/ 64%RH
Test Item	Harmonic	Test Date	May 6, 2021
Polarize	Horizontal	Test Engineer	Ray Li
Detector	Peak		

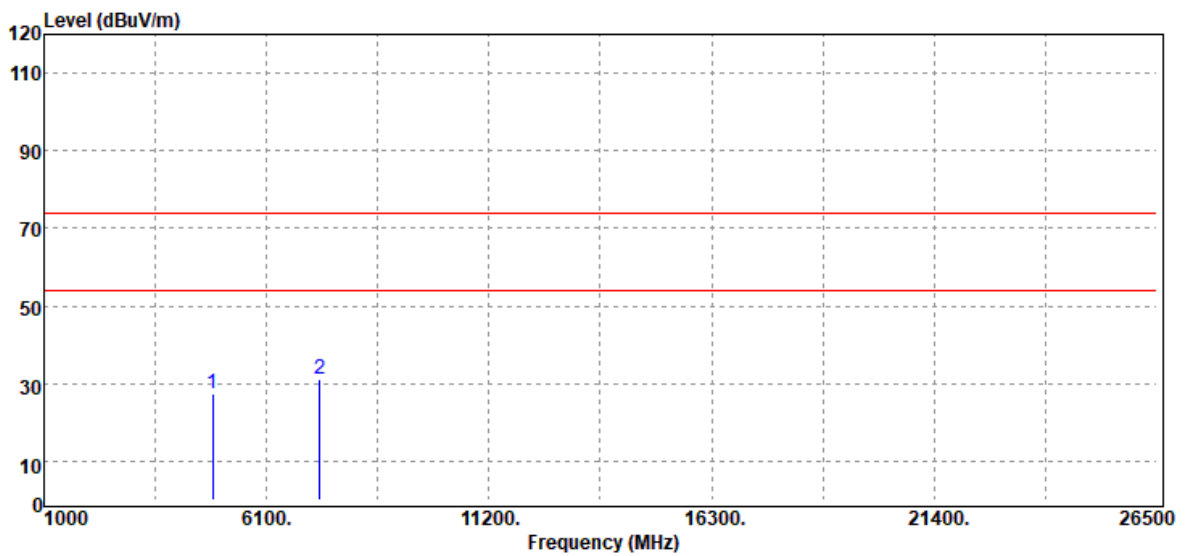

Freq. (MHz)	Detector Mode (PK/QP/AV)	Spectrum Reading Level (dBµV)	Factor (dB)	Actual FS (dBµV/m)	Limit @3m (dBµV/m)	Margin (dB)
4874.00	Peak	33.61	-6.00	27.61	74.00	-46.39
7311.00	Peak	32.00	-0.92	31.08	74.00	-42.92
N/A						

Remark:

1. Measuring frequencies from 1 GHz to the 10th harmonic of highest fundamental frequency.
2. For above 1GHz, the EUT peak value was under average limit, therefore the Average value compliance with the average limit

Report No.: T210324W02-RP1

Test Mode	IEEE 802.11g High CH	Temp/Hum	23.6(°C)/ 64%RH
Test Item	Harmonic	Test Date	May 6, 2021
Polarize	Vertical	Test Engineer	Ray Li
Detector	Peak		

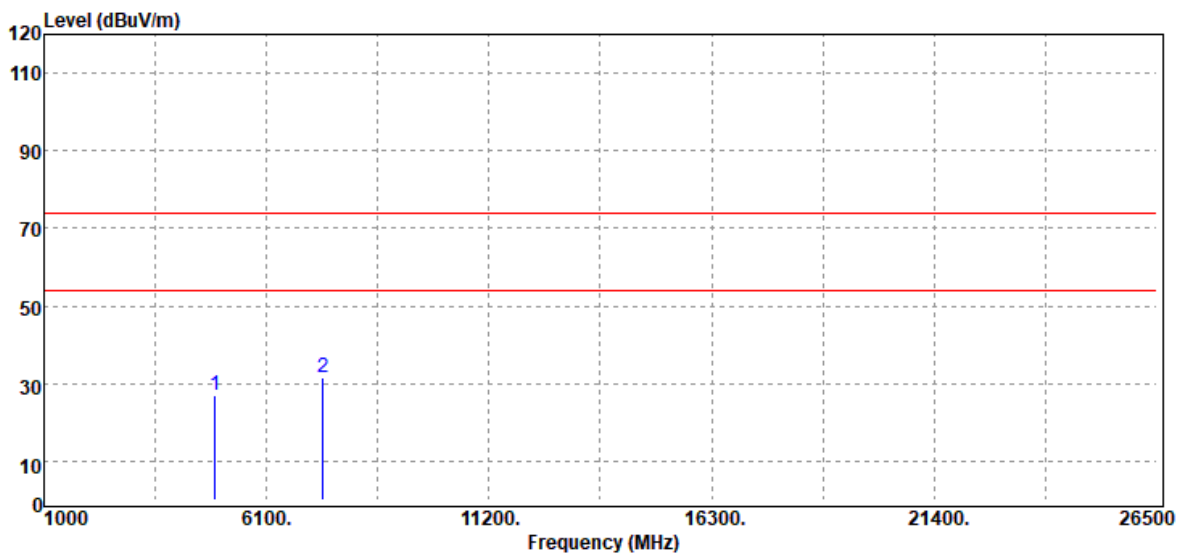

Freq. (MHz)	Detector Mode (PK/QP/AV)	Spectrum Reading Level (dBμV)	Factor (dB)	Actual FS (dBμV/m)	Limit @3m (dBμV/m)	Margin (dB)
4924.00	Peak	32.71	-5.62	27.09	74.00	-46.91
7386.00	Peak	32.40	-0.68	31.72	74.00	-42.28
N/A						

Remark:

1. Measuring frequencies from 1 GHz to the 10th harmonic of highest fundamental frequency.
2. For above 1GHz, the EUT peak value was under average limit, therefore the Average value compliance with the average limit

Report No.: T210324W02-RP1

Test Mode	IEEE 802.11g High CH	Temp/Hum	23.6(°C)/ 64%RH
Test Item	Harmonic	Test Date	May 6, 2021
Polarize	Horizontal	Test Engineer	Ray Li
Detector	Peak		

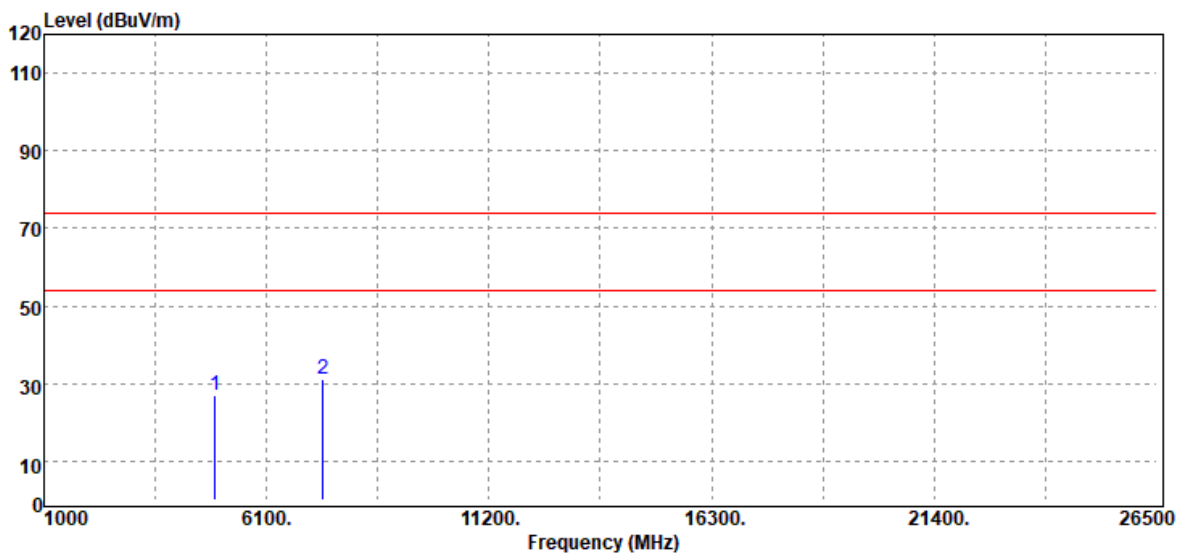

Freq. (MHz)	Detector Mode (PK/QP/AV)	Spectrum Reading Level (dBµV)	Factor (dB)	Actual FS (dBµV/m)	Limit @3m (dBµV/m)	Margin (dB)
4924.00	Peak	32.78	-5.62	27.16	74.00	-46.84
7386.00	Peak	31.65	-0.68	30.97	74.00	-43.03
N/A						

Remark:

1. Measuring frequencies from 1 GHz to the 10th harmonic of highest fundamental frequency.
2. For above 1GHz,the EUT peak value was under average limit, therefore the Average value compliance with the average limit

Report No.: T210324W02-RP1

Test Mode	IEEE 802.11n HT20 Low CH	Temp/Hum	23.6(°C)/ 64%RH
Test Item	Harmonic	Test Date	May 6, 2021
Polarize	Vertical	Test Engineer	Ray Li
Detector	Peak		

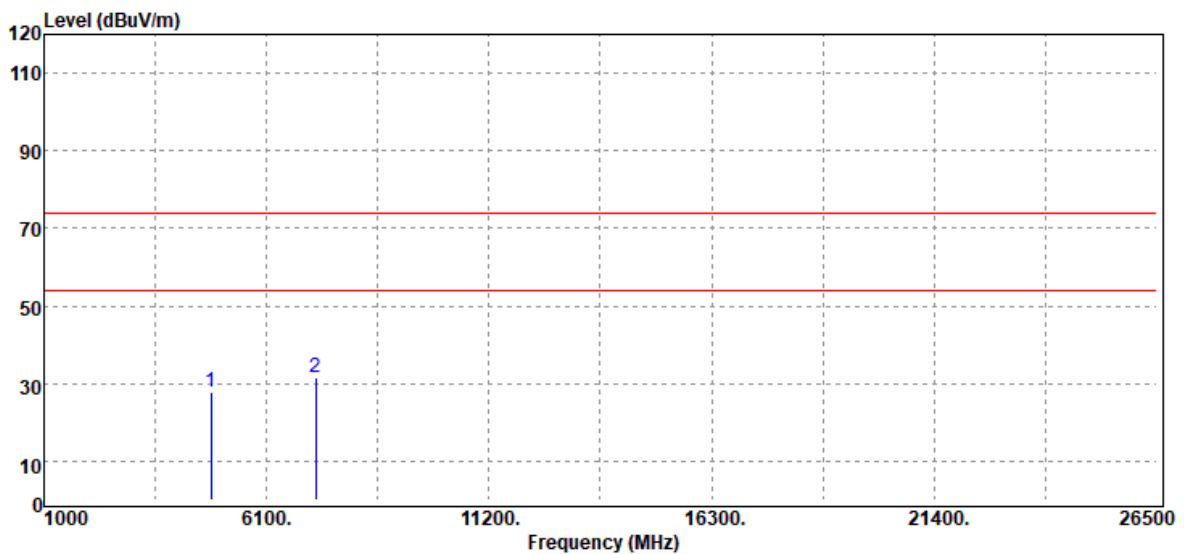

Freq. (MHz)	Detector Mode (PK/QP/AV)	Spectrum Reading Level (dBµV)	Factor (dB)	Actual FS (dBµV/m)	Limit @3m (dBµV/m)	Margin (dB)
4824.00	Peak	33.97	-6.11	27.86	74.00	-46.14
7236.00	Peak	32.56	-0.88	31.68	74.00	-42.32
N/A						

Remark:

1. Measuring frequencies from 1 GHz to the 10th harmonic of highest fundamental frequency.
2. For above 1GHz,the EUT peak value was under average limit, therefore the Average value compliance with the average limit

Report No.: T210324W02-RP1

Test Mode	IEEE 802.11n HT20 Low CH	Temp/Hum	23.6(°C)/ 64%RH
Test Item	Harmonic	Test Date	May 6, 2021
Polarize	Horizontal	Test Engineer	Ray Li
Detector	Peak		

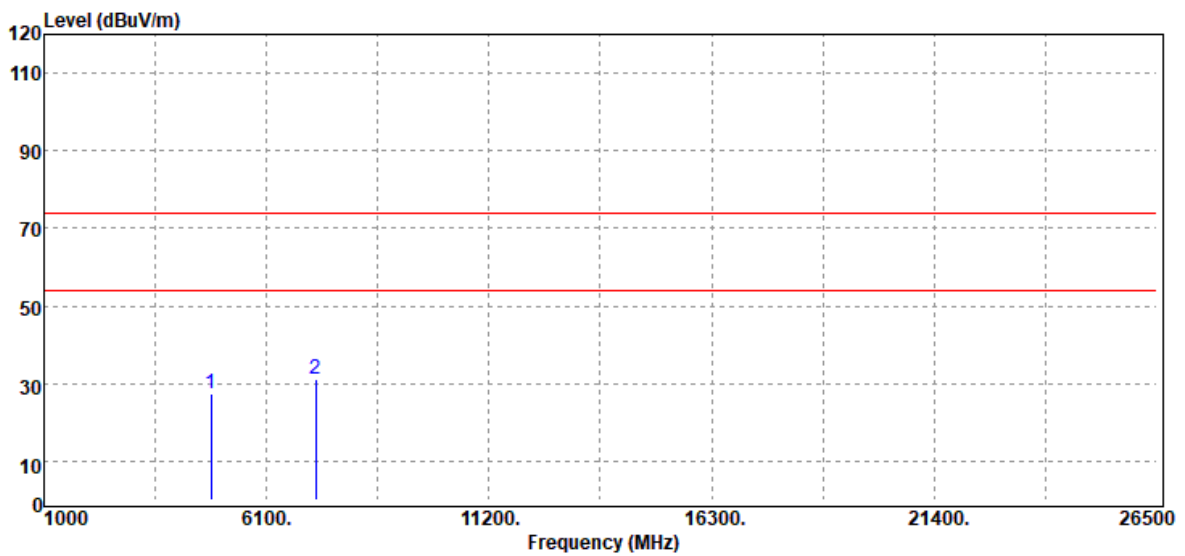

Freq. (MHz)	Detector Mode (PK/QP/AV)	Spectrum Reading Level (dBµV)	Factor (dB)	Actual FS (dBµV/m)	Limit @3m (dBµV/m)	Margin (dB)
4824.00	Peak	33.40	-6.11	27.29	74.00	-46.71
7236.00	Peak	31.97	-0.88	31.09	74.00	-42.91
N/A						

Remark:

1. Measuring frequencies from 1 GHz to the 10th harmonic of highest fundamental frequency.
2. For above 1GHz, the EUT peak value was under average limit, therefore the Average value compliance with the average limit

Report No.: T210324W02-RP1

Test Mode	IEEE 802.11n HT20 Mid CH	Temp/Hum	23.6(°C)/ 64%RH
Test Item	Harmonic	Test Date	May 6, 2021
Polarize	Vertical	Test Engineer	Ray Li
Detector	Peak		

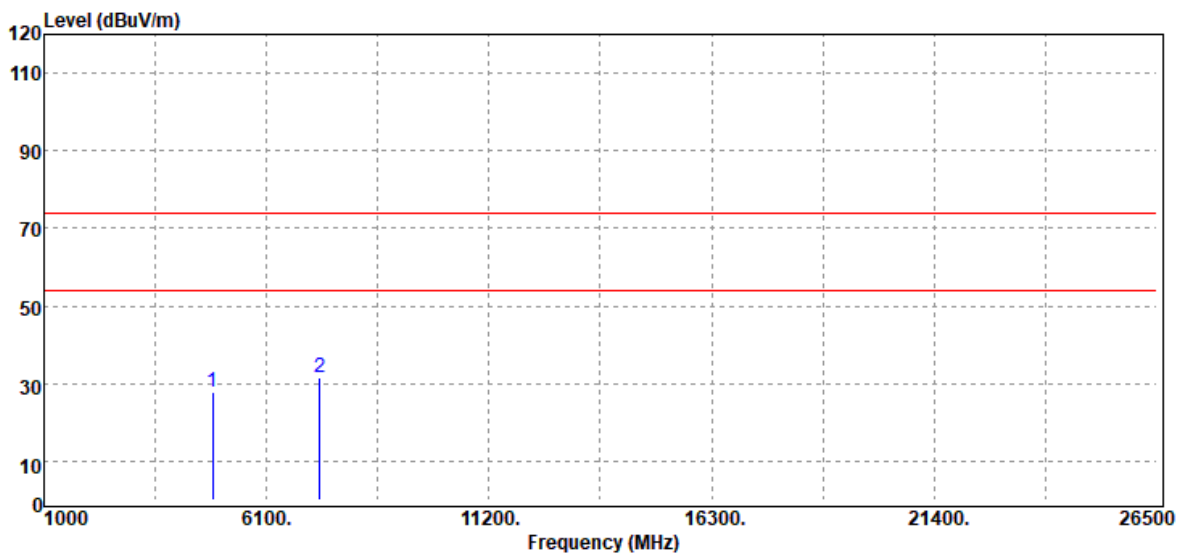

Freq. (MHz)	Detector Mode (PK/QP/AV)	Spectrum Reading Level (dBμV)	Factor (dB)	Actual FS (dBμV/m)	Limit @3m (dBμV/m)	Margin (dB)
4874.00	Peak	33.68	-6.00	27.68	74.00	-46.32
7311.00	Peak	32.37	-0.92	31.45	74.00	-42.55
N/A						

Remark:

1. Measuring frequencies from 1 GHz to the 10th harmonic of highest fundamental frequency.
2. For above 1GHz, the EUT peak value was under average limit, therefore the Average value compliance with the average limit

Report No.: T210324W02-RP1

Test Mode	IEEE 802.11n HT20 Mid CH	Temp/Hum	23.6(°C)/ 64%RH
Test Item	Harmonic	Test Date	May 6, 2021
Polarize	Horizontal	Test Engineer	Ray Li
Detector	Peak		

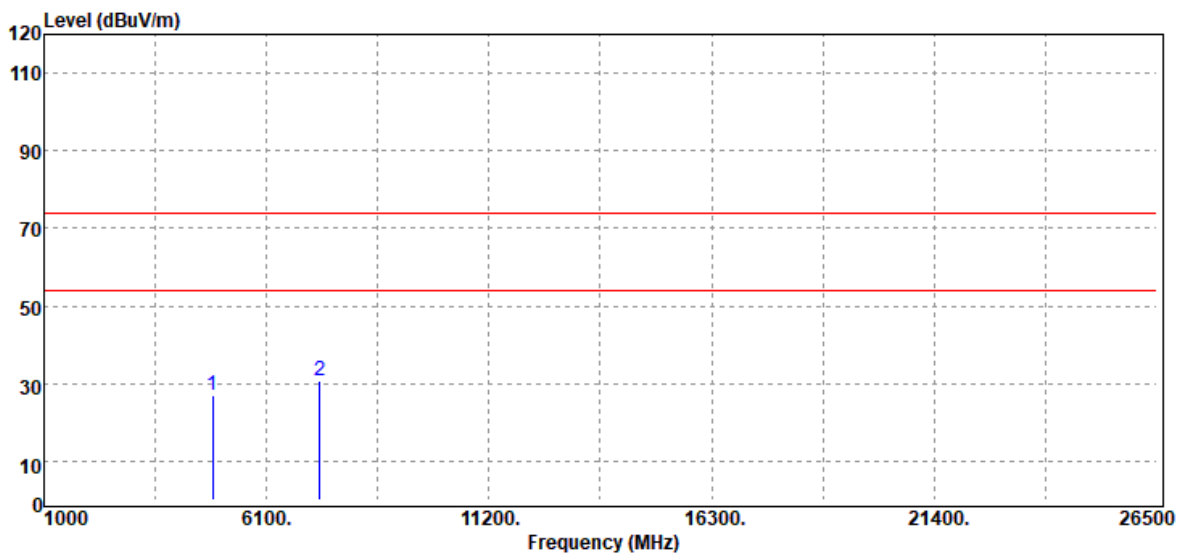

Freq. (MHz)	Detector Mode (PK/QP/AV)	Spectrum Reading Level (dBµV)	Factor (dB)	Actual FS (dBµV/m)	Limit @3m (dBµV/m)	Margin (dB)
4874.00	Peak	32.94	-6.00	26.94	74.00	-47.06
7311.00	Peak	31.82	-0.92	30.90	74.00	-43.10
N/A						

Remark:

1. Measuring frequencies from 1 GHz to the 10th harmonic of highest fundamental frequency.
2. For above 1GHz,the EUT peak value was under average limit, therefore the Average value compliance with the average limit

Report No.: T210324W02-RP1

Test Mode	IEEE 802.11n HT20 High CH	Temp/Hum	23.6(°C)/ 64%RH
Test Item	Harmonic	Test Date	May 6, 2021
Polarize	Vertical	Test Engineer	Ray Li
Detector	Peak		

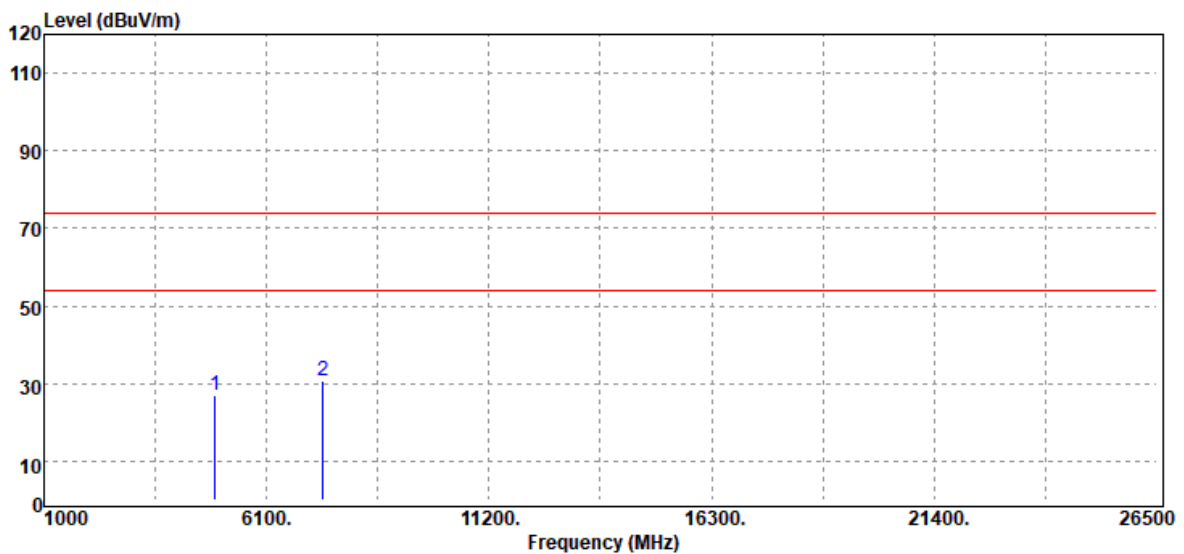

Freq. (MHz)	Detector Mode (PK/QP/AV)	Spectrum Reading Level (dBµV)	Factor (dB)	Actual FS (dBµV/m)	Limit @3m (dBµV/m)	Margin (dB)
4924.00	Peak	32.57	-5.62	26.95	74.00	-47.05
7386.00	Peak	31.57	-0.68	30.89	74.00	-43.11
N/A						

Remark:

1. Measuring frequencies from 1 GHz to the 10th harmonic of highest fundamental frequency.
2. For above 1GHz, the EUT peak value was under average limit, therefore the Average value compliance with the average limit

Report No.: T210324W02-RP1

Test Mode	IEEE 802.11n HT20 High CH	Temp/Hum	23.6(°C)/ 64%RH
Test Item	Harmonic	Test Date	May 6, 2021
Polarize	Horizontal	Test Engineer	Ray Li
Detector	Peak		

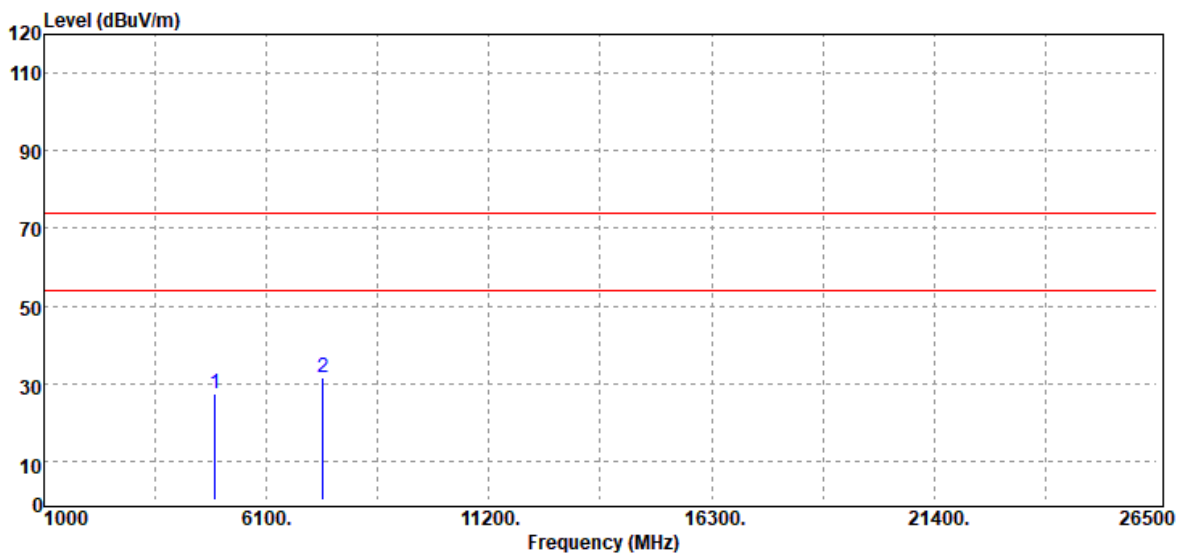

Freq. (MHz)	Detector Mode (PK/QP/AV)	Spectrum Reading Level (dBµV)	Factor (dB)	Actual FS (dBµV/m)	Limit @3m (dBµV/m)	Margin (dB)
4924.00	Peak	32.85	-5.62	27.23	74.00	-46.77
7386.00	Peak	32.22	-0.68	31.54	74.00	-42.46
N/A						

Remark:

1. Measuring frequencies from 1 GHz to the 10th harmonic of highest fundamental frequency.
2. For above 1GHz,the EUT peak value was under average limit, therefore the Average value compliance with the average limit

Report No.: T210324W02-RP1

Test Mode	IEEE 802.11n HT40 Low CH	Temp/Hum	23.6(°C)/ 64%RH
Test Item	Harmonic	Test Date	May 6, 2021
Polarize	Vertical	Test Engineer	Ray Li
Detector	Peak		

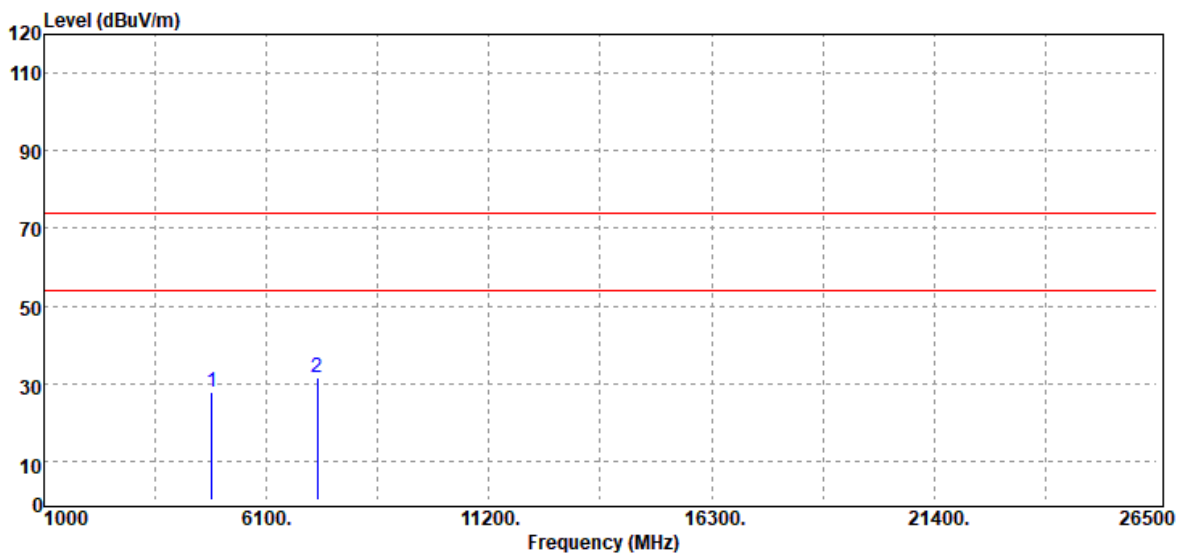

Freq. (MHz)	Detector Mode (PK/QP/AV)	Spectrum Reading Level (dBµV)	Factor (dB)	Actual FS (dBµV/m)	Limit @3m (dBµV/m)	Margin (dB)
4844.00	Peak	33.97	-6.09	27.88	74.00	-46.12
7266.00	Peak	32.34	-0.93	31.41	74.00	-42.59
N/A						

Remark:

1. Measuring frequencies from 1 GHz to the 10th harmonic of highest fundamental frequency.
2. For above 1GHz,the EUT peak value was under average limit, therefore the Average value compliance with the average limit

Report No.: T210324W02-RP1

Test Mode	IEEE 802.11n HT40 Low CH	Temp/Hum	23.6(°C)/ 64%RH
Test Item	Harmonic	Test Date	May 6, 2021
Polarize	Horizontal	Test Engineer	Ray Li
Detector	Peak		

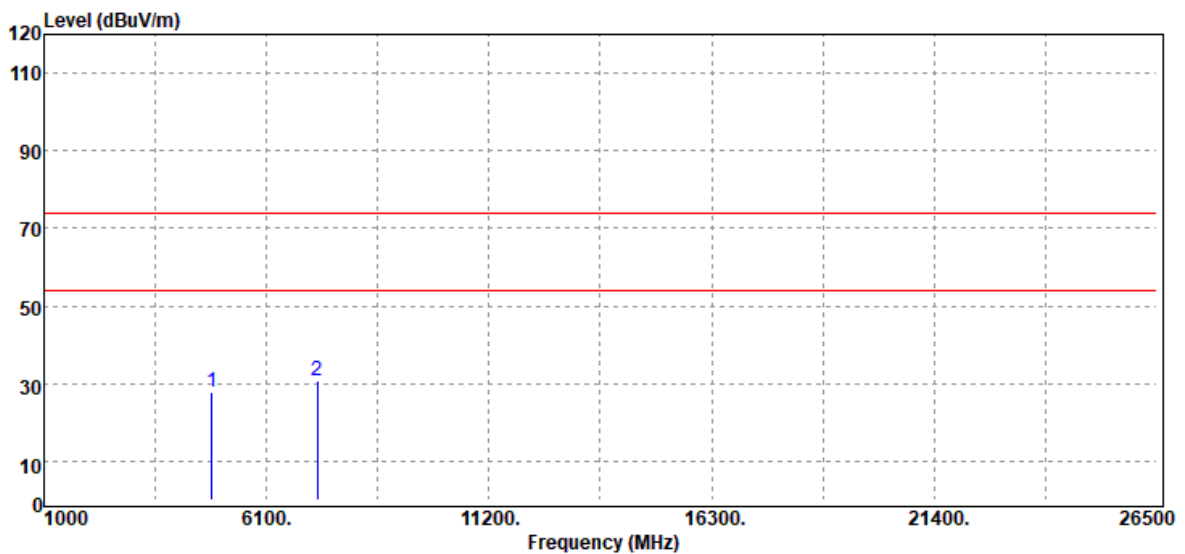

Freq. (MHz)	Detector Mode (PK/QP/AV)	Spectrum Reading Level (dBµV)	Factor (dB)	Actual FS (dBµV/m)	Limit @3m (dBµV/m)	Margin (dB)
4844.00	Peak	34.08	-6.09	27.99	74.00	-46.01
7266.00	Peak	31.76	-0.93	30.83	74.00	-43.17
N/A						

Remark:

1. Measuring frequencies from 1 GHz to the 10th harmonic of highest fundamental frequency.
2. For above 1GHz, the EUT peak value was under average limit, therefore the Average value compliance with the average limit

Report No.: T210324W02-RP1

Test Mode	IEEE 802.11n HT40 Mid CH	Temp/Hum	23.6(°C)/ 64%RH
Test Item	Harmonic	Test Date	May 6, 2021
Polarize	Vertical	Test Engineer	Ray Li
Detector	Peak		

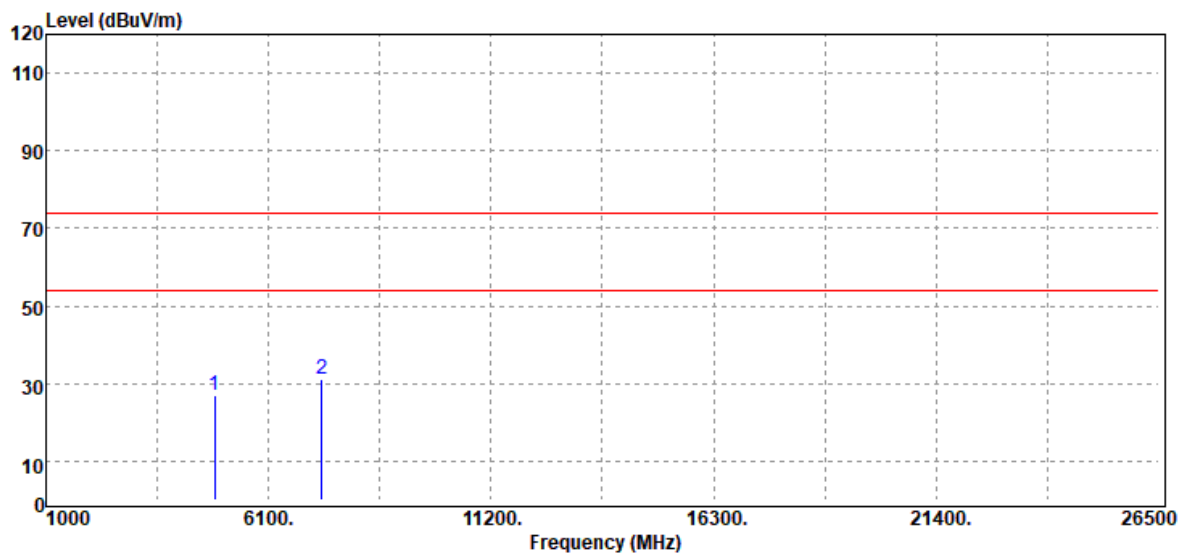

Freq. (MHz)	Detector Mode (PK/QP/AV)	Spectrum Reading Level (dBμV)	Factor (dB)	Actual FS (dBμV/m)	Limit @3m (dBμV/m)	Margin (dB)
4874.00	Peak	33.13	-6.00	27.13	74.00	-46.87
7311.00	Peak	32.08	-0.92	31.16	74.00	-42.84
N/A						

Remark:

1. Measuring frequencies from 1 GHz to the 10th harmonic of highest fundamental frequency.
2. For above 1GHz, the EUT peak value was under average limit, therefore the Average value compliance with the average limit

Report No.: T210324W02-RP1

Test Mode	IEEE 802.11n HT40 Mid CH	Temp/Hum	23.6(°C)/ 64%RH
Test Item	Harmonic	Test Date	May 6, 2021
Polarize	Horizontal	Test Engineer	Ray Li
Detector	Peak		

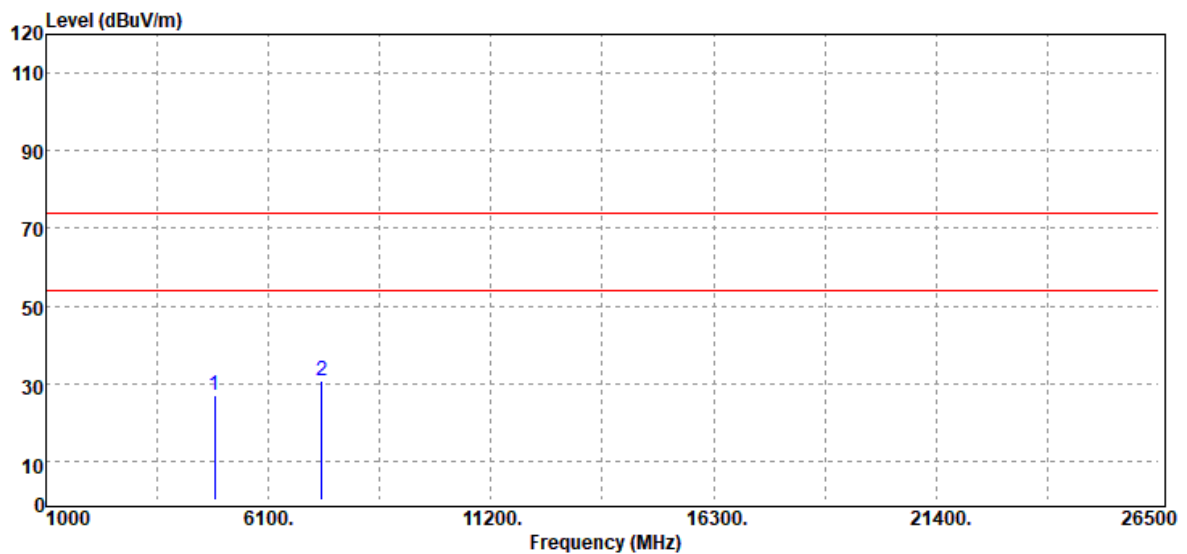

Freq. (MHz)	Detector Mode (PK/QP/AV)	Spectrum Reading Level (dBμV)	Factor (dB)	Actual FS (dBμV/m)	Limit @3m (dBμV/m)	Margin (dB)
4874.00	Peak	32.81	-6.00	26.81	74.00	-47.19
7311.00	Peak	31.70	-0.92	30.78	74.00	-43.22
N/A						

Remark:

1. Measuring frequencies from 1 GHz to the 10th harmonic of highest fundamental frequency.
2. For above 1GHz,the EUT peak value was under average limit, therefore the Average value compliance with the average limit

Report No.: T210324W02-RP1

Test Mode	IEEE 802.11n HT40 High CH	Temp/Hum	23.6(°C)/ 64%RH
Test Item	Harmonic	Test Date	May 6, 2021
Polarize	Vertical	Test Engineer	Ray Li
Detector	Peak		

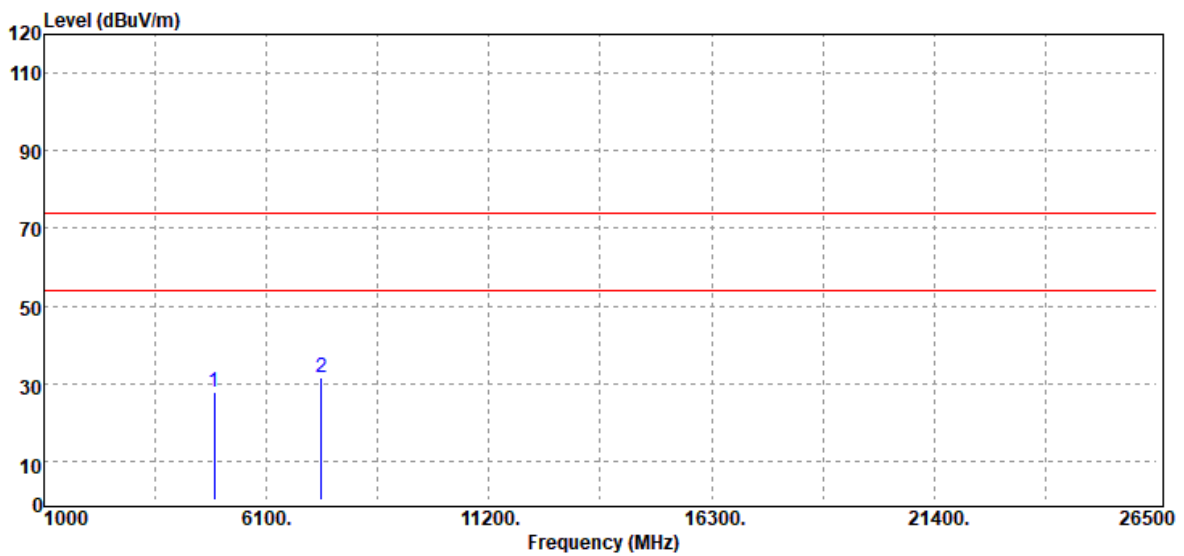

Freq. (MHz)	Detector Mode (PK/QP/AV)	Spectrum Reading Level (dBµV)	Factor (dB)	Actual FS (dBµV/m)	Limit @3m (dBµV/m)	Margin (dB)
4904.00	Peak	33.60	-5.86	27.74	74.00	-46.26
7356.00	Peak	32.34	-0.72	31.62	74.00	-42.38
N/A						

Remark:

1. Measuring frequencies from 1 GHz to the 10th harmonic of highest fundamental frequency.
2. For above 1GHz, the EUT peak value was under average limit, therefore the Average value compliance with the average limit

Report No.: T210324W02-RP1

Test Mode	IEEE 802.11n HT40 High CH	Temp/Hum	23.6(°C)/ 64%RH
Test Item	Harmonic	Test Date	May 6, 2021
Polarize	Horizontal	Test Engineer	Ray Li
Detector	Peak		

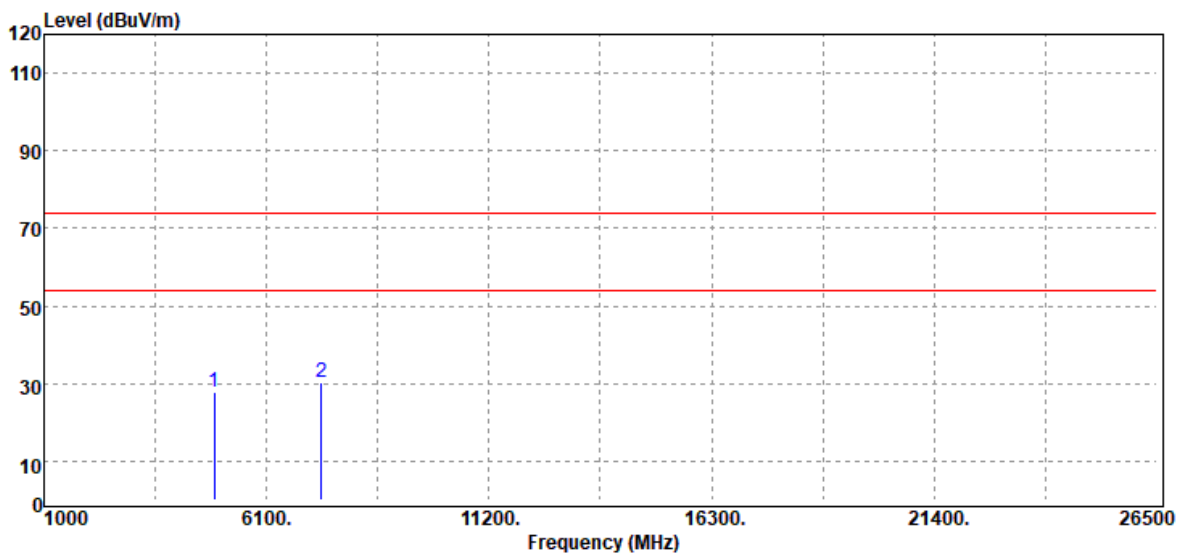

Freq. (MHz)	Detector Mode (PK/QP/AV)	Spectrum Reading Level (dBμV)	Factor (dB)	Actual FS (dBμV/m)	Limit @3m (dBμV/m)	Margin (dB)
4904.00	Peak	33.65	-5.86	27.79	74.00	-46.21
7356.00	Peak	31.01	-0.72	30.29	74.00	-43.71
N/A						

Remark:

1. Measuring frequencies from 1 GHz to the 10th harmonic of highest fundamental frequency.
2. For above 1GHz, the EUT peak value was under average limit, therefore the Average value compliance with the average limit

- End of Test Report -