

承认书

SPECIFICATION FOR APPROVAL

客户名称 (CUSTOMER): 立景科技有限公司

客户料号 (CUSTOMER P/N):

品名 (DESCRIPTION): DATE: 2022-5-13

规格 (SPECIFICATION): A11开L槽+背胶引线长25mm REV.NO.: A0

鸿日昇威科技承认签核、盖章

部门	确认/日期	审核/日期	批准/日期	(盖公司公章)
品质	董晚红 ₂₀₂₂₋₅₋₁₃	吕惠 ₂₀₂₂₋₅₋₁₃	韦函满 ₂₀₂₂₋₅₋₁₃	
工程	何伟华 ₂₀₂₂₋₅₋₁₃	韦立红 ₂₀₂₂₋₅₋₁₃	韦立红 ₂₀₂₂₋₅₋₁₃	

备注:

立景科技承认签核、盖章

部门	确认/日期	审核/日期	批准/日期	(盖公司公章)
开发工程师				
采购				
品质				

备注:

深圳市鸿日昇威科技有限公司

HRSW ELECTRONICS CO.,LTD

ADD: 深圳市龙华新区观澜环观中路48号1栋2楼

TEL: +86-755-23461055 FAX: +86-0755-28015170

page: 1/3

SPECIFICATION FOR APPROVAL

1. MECHANICAL DIMENSION (UNIT:mm)

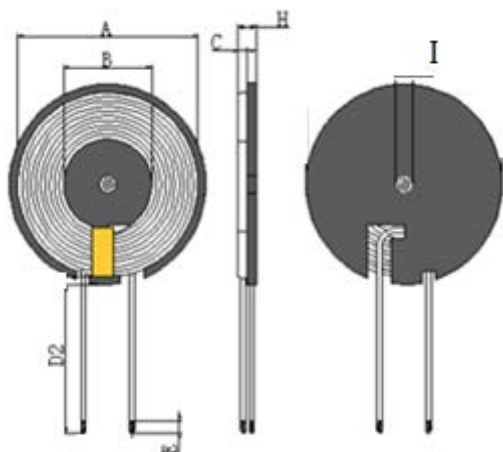

2. SCHEMATICS:

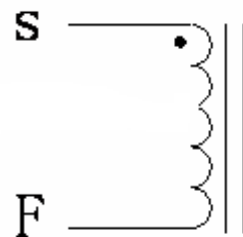

1. 线圈贴磁片，磁片尺寸
50±1mm,
开L线槽。
2. 线圈出线位置
缠胶纸 1-2Ts;
3. 隔磁片底部要贴胶

A	B	C	D2	E	H	I			I
50±1.0	20.5±0.5	1.0±0.05	25±3	4±2	2.8MAX	5±0.5			

3. WINDING:

STEP	START-FINISH	WIRE TYPE	TURNS	TAPE	REMARK
N1	S-F	丝包线 0.08*105mm 2UEW	10TS (Ref)		

4. ELECTRICAL SPECIFICATION:

ITEM	L	DCR	L	Q值	HI-POT
TEST	线圈加磁片	S-F	单独线圈		
CON	100KHz, 0.25V	AT 25°C	100KHz, 0.25V		
SPEC	6.5uH±10%	70mΩ Max	3.8uH±15%		

5. BILF OF MATERIAL:

NO.	ITEM	MATERIAL SPECIFICATION	MANUFACTURER	SGS NO.
1	丝包线0.08*105股	丙酮丝包线0.08*105股	NANJINGJINNINGCO,LTD	
2	无铅锡条	无铅锡条	QIAODO	
3	磁片	ø50锰锌硬磁片开L槽	TAIYI CO.,LTD	
4	胶水	黄胶9999	LIANCHENG CO.,LTD	
5	高温胶纸	8mm宽高温胶纸	CUDAK CO.,LTD	
6	背胶	49*0.1	CUDAK CO.,LTD	

HRSW ELECTRONICS CO.,LTD	PART NO	
	TITLE	A11开L槽+背胶引线长25mm
DRAWN BY	CHECKED BY	APPROVED BY
何伟华	韦立红	韦立红

SPECIFICATION FOR APPROVAL

6. SAMPLE TEST DATA									
6. 1DIMENSION TEST (UNIT: mm)									
TEST ITEM	A	B	C	D	E	H	I		
SPEC	50±1.0	20.5±0.5	1.0±0.05	25±3	4±2	2.8MAX	5±0.5		
1	49.8	20.65	1.01	25	3.50	2.55	5.01		
2	49.9	20.63	0.99	24.6	3.60	2.56	5.03		
3	49.5	20.65	0.98	25.3	3.70	2.49	4.99		
4	50	20.055	0.96	24.69	3.80	2.52	5		
5	49.86	20.45	1	24.28	4.00	2.50	5.01		
6									
7									
8									
9									
10									
MAX	50.00	20.65	1.01	25.30	4.00	2.56	5.03		
MIN	49.50	20.06	0.96	24.28	3.50	2.49	4.99		
AVERAGE	49.81	20.49	0.99	24.77	3.72	2.52	5.01		
6. 2ELECTRICAL TEST									
TEST ITEM	L		DCR	IDC		Q	HI-POT		
	S-F		S-F						
TEST COND	100KHz/0.25v		AT 25°C						
SPEC	6.5uH ±10%		70mΩ (Max)						
1	6.51		52.00						
2	6.52		53.00						
3	6.49		51.00						
4	6.53		49.00						
5	6.52		50.00						
6									
7									
8									
9									
10									
MAX	6.53		53.00						
MIN	6.49		49.00						
AVERAGE	6.51		51.00						
HRSW ELECTRONICS CO., LTD					PART NO				
					TITLE			A11开L槽+背胶引线25mm	
DRAWN BY			CHECKED BY			APPROVED BY			
何伟华			韦立红			韦立红			