

# 承认书

## SPECIFICATION FOR APPROVAL

客户名称 (CUSTOMER) : 深圳市立景科技有限公司

客户料号 (CUSTOMER P/N) : 磁吸线圈

品名 (DESCRIPTION) : \_\_\_\_\_ DATE: 2023/11/8

规格 (SPECIFICATION) : G43开槽+背胶 0.07\*100 10UH 30长 REV.NO.: A0

### 鸿日昇威科技承认签核、盖章

部门	确认/日期	审核/日期	批准/日期	(盖公司公章)
品质	董晚红	吕惠	韦函满	
工程	何伟华	韦红	韦红	

备注:

### 立景科技承认签核、盖章

部门	确认/日期	审核/日期	批准/日期	(盖公司公
----	-------	-------	-------	-------

开发工程				章
采购				
品质				
备注：				
<p>深圳市鸿日昇威科技有限公司</p> <p><b>HRSW ELECTRONICS CO.,LTD</b></p> <p><b>ADD: 深圳市龙华新区观澜环观中路48号1栋2楼</b></p> <p><b>TEL: 13682412162</b></p>				
				page:1/2

## SPECIFICATION FOR APPROVAL

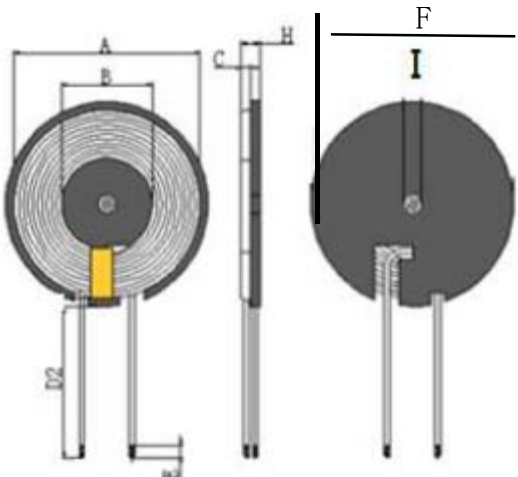
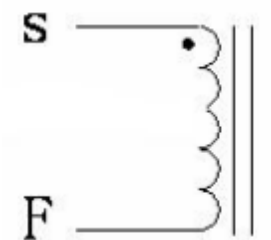
<p><b>1.MECHANICAL DIMENSION (UNIT:mm)</b></p> 	<p><b>2. SCHEMATICS:</b></p>  <ol style="list-style-type: none"> <li>1.Coil attached magnetic sheet, magnetic sheet size:43.5mm±0.5MM, thickness:0.8±0.05mm, open L-line slot.</li> <li>2. Coil outlet position wrap adhesive tape 1-2Ts;</li> <li>3. The bottom of the magnet insulation sheet should be glued.</li> </ol>
---	---

A	B	C	D2	E	H	I	F
41.5±0.3	13.5±0.3	0.8±0.05	30±2	3±1	2.3MAX	5±1	43.3+0-0.3

### 3.WINDING:

STEP	START-FINISH	WIRE TYPE	TURNS	TAPE	REMARK
N1	S-F	silk covered wireø0.07* 100mm 2UEW	15TS (Ref)		

### 4. ELECTRICAL SPECIFICATION:

ITEM	L	DCR	L	HI-POT
TEST CON	Coil+ magnetic sheet	S-F	Individual coil	
	100KHz, 0.25V	AT 25°C	100KHz, 0.25V	
SPEC	10uH+0-1	80mΩ Max	6.2uH±10%	

### 5.BILF OF MATERIAL:

NO.	ITEM	MATERIAL SPECIFICATION	MANUFACTURER	SGS NO.
1	silk covered wire 0.07* 100 strand	Acetone silk covered wire 0.07* 100 strand	NANJINGJINNINGCO,LTD	
2	Lead-free tin strip	Lead-free tin strip	QIAODO	
3	Magnetic sheet	Ø 44*0.8 Manganese-zinc hard magnetic sheet with L slot	TAIYI CO.,LTD	
4	Adhesive	Chloroprene Adhesive9999	LIANCHENG CO.,LTD	
5	High temperature adhesive tape	7mm wide high temperature adhesive tape	CUDAK CO.,LTD	
6	Back Adhesive	Ø 41.5*0.1/3M	CUDAK CO.,LTD	

HRSW ELECTRONICS CO.,LTD	PART NO	
	TITLE	G43.5 with slot + Back adhesive 10UH

DRAWN BY	CHECKED BY	APPROVED BY
He weihua	Wei lihong	Wei lihong