

AC-30 15W产品说明书

尺寸: 350*100mm 单面印刷 材质: 157克铜版纸

User Manual Wireless Car Charger

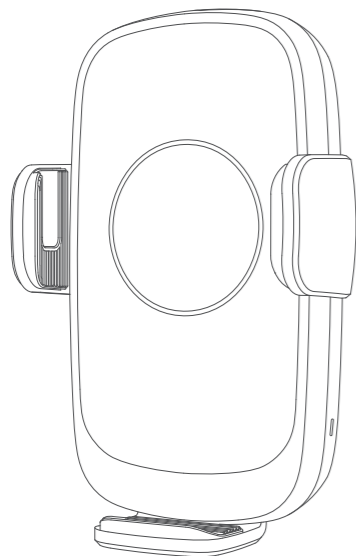

Product Features

- 1.Top backside touch button,touch to open and easy for one hand operation. Charging indicator on both sides, and the center of the product comes with a 7-color circular indicator light that can be cycled.Touch the button at the bottom of the back to adjust the color of the light.
- 2.Built-in wireless charging transmitter coil, the two arms and feet will automatic closing when put the phone on the charger, The transmitter coil automatically starts to find the mobile phone charging coil, and the mobile phone starts wireless charging after coil precise alignment.
- 3.Suitable for different size phones,anti-slip silicone on both arms and feet,Type-C charging port.
- 4.Built-in stepper motor, it works with low noise.
- 5.NPO capacitors,lower charging temperature and high charging efficiency.
- 6.Standby mode: the green and blue LED indicator light flashes alternatively,then the green indicator light keeps on.
- 7.Charging mode: the blue LED indicator light keeps on,the light turns to green if remove the receiver.
- 8.FOD function: when put metal or magnet objects on the charger, the blue and green LED indicator light will flash for reminding.
- 9.Perfect protective function based on over-voltage, over-current, over-temperature and short-circuit protection.

Specifications

| | |
|---------------------|----------------------------|
| Input | DC 12V/1.5A,9V/1.67A,5V/2A |
| Output | 15W/10W/5W |
| Product Standard | Qi |
| Charging Distance | <= 10mm |
| Charging Efficiency | <= 80% |
| Product Dimension | Φ72.5*74*116.3mm |
| Product Material | ABS+Tempered Glass |

※ Fast wireless charging requires quick 18W or 18W above adapter.

Product Parts Description 1

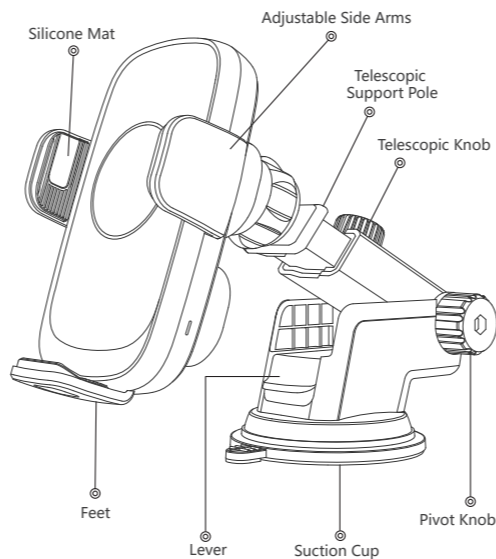

Product Parts Description 2

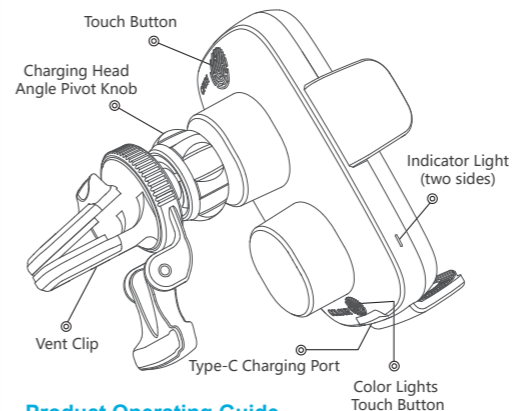

Product Operating Guide

1. Please make sure the product connect to the power before using.
2. The green LED indicator light on if connected with power.
3. The LED indicator light will flashes and the product stop charging when the current is too large or there is foreign object. Do not wireless charging the phone if similar situation happened.
4. Please touch the backside power button to open the two arms, the wireless charging start and the two arms will closing automatically once you put the phone on the charger. Only need to touch the power button again to release two arms and easily remove the phone.
5. Please purchase the wireless receiver module or case separately (Not included in the product) if your phone do not support wireless charging.

Attention

- 1.Please do not vigorously extrude or collide.
- 2.Please do not dismantle or put it into fire or water when the product is power on,to avoid short circuit or leakage.
- 3.Please do not use it in severely high temperature,high humidity or corrosive environment,to avoid damage to the circuit leakage.
- 4.Please do not put the magnetic strip or chip card (Such as ID card,bankcard etc.)on the charging pad to avoid to cause magneticcard lose efficacy.
- 5.Please do not put the metal (Such as coin etc.) on the charging pad when charging,to avoid damage from heating.

FCC Warning

This device complies with part 15 of the FCC Rules. Operation is subject to the following two conditions:(1) This device may not cause harmful interference, and (2) this device must accept any interference received, including interference that may cause undesired operation.

Any Changes or modifications not expressly approved by the party responsible for compliance could void the user's authority to operate the equipment.

This equipment has been tested and found to comply with the limits for a Class B digital device, pursuant to part 15 of the FCC Rules. These limits are designed to provide reasonable protection against harmful interference in a residential installation. This equipment generates uses and can radiate radio frequency energy and, if not installed and used in accordance with the instructions, may cause harmful interference to radio communications. However, there is no guarantee that interference will not occur in a particular installation. If this equipment does cause harmful interference to radio or television reception, which can be determined by turning the equipment off and on, the user is encouraged to try to correct the interference by one or more of the following measures:

- Reorient or relocate the receiving antenna.
- Increase the separation between the equipment and receiver.
- Connect the equipment into an outlet on a circuit different from that to which the receiver is connected.
- Consult the dealer or an experienced radio/TV technician for help.

FCC RF exposure statement:

The equipment complies with FCC radiation exposure limits set forth for an uncontrolled environment. This equipment should be installed and operated with minimum distance between 20cm the radiator your body.