

# SPECIFICATION FOR APPROVAL

## 1.MECHANICAL DIMENSION (UNIT:mm)

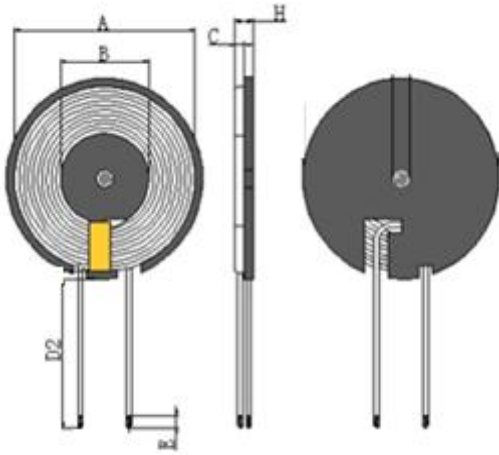

## 2. SCHEMATICS:

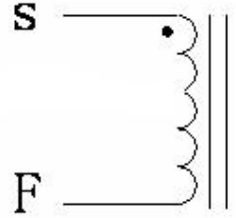

- 1.Coil attached magnetic sheet, magnetic sheet size:  
50±1mm,  
Open L-line slot.
- 2.Coil outlet position  
wrap adhesive tape 1-2Ts;
- 3.The bottom of the magnet insulation sheet should be glued

A	B	C	D2	E	H				I
50±1.0	20.5±0.5	0.9±0.05	60±2	3±1.5	2.8MAX				

## 3.WINDING:

STEP	START-FINISH	WIRE TYPE	TURNS	TAPE	REMARK
N1	S-F	silk covered wire Ø 0.08*105mm 2UEW	10TS (Ref)		

## 4. ELECTRICAL SPECIFICATION:

ITEM	L	DCR	L	Q value	HI-POT
TEST	Coil+ magnetic sheet	S-F	Individual coil		
CON	100KHz, 0.25V	AT 25°C	100KHz, 0.25V		
SPEC	6.3uH±10%	70mΩ Max	3.8uH±15%		

## 5.BILF OF MATERIAL:

NO.	ITEM	MATERIAL SPECIFICATION	MANUFACTURER	SGS NO.
1	silk covered wire 0.08*105 strand	Acetone silk covered wire 0.08*105 strand	NANJINGJINNINGCO,LTD	
2	Lead-free tin strip	Lead-free tin strip	QIAODO	
3	Magnetic sheet	Ø 50*1.0 Manganese-zinc hard magnetic sheet with L slot	TAIYI CO.,LTD	
4	Adhesive	Chloroprene Adhesive 9999	LIANCHENG CO.,LTD	
5	High temperature adhesive tape	8mm wide high temperature adhesive tape	CUDAK CO.,LTD	
6	Back Adhesive	Ø 48.5*0.1	CUDAK CO.,LTD	

HRSW ELECTRONICS CO.,LTD	PART NO	
	TITLE	G50 single coil slotting+ Back adhesive
DRAWN BY	CHECKED BY	APPROVED BY

Xie Chao	He weihua	Wei lihong
----------	-----------	------------

# SPECIFICATION FOR APPROVAL

6. SAMPLE TEST DATA									
6. 1DIMENSION TEST (UNIT:mm)									
TEST ITEM	A	B	C	D	E	H			
SPEC	50±1.0	20.5±0.5	0.9±0.05	60±2	3±1.5	2.8MAX			
1	49.8	20.65	0.89	62	3.50	2.55			
2	49.9	20.63	0.9	61	3.60	2.56			
3	49.8	20.65	0.92	61.5	3.70	2.49			
4	50	20.055	0.9	61.4	3.80	2.52			
5	49.86	20.45	0.9	62.3	4.00	2.50			
6									
7									
8									
9									
10									
MAX	50.00	20.65	0.92	62.30	4.00	2.56			
MIN	49.80	20.06	0.89	61.00	3.50	2.49			
AVERAGE	49.87	20.49	0.90	61.64	3.72	2.52			
6. 2ELECTRICAL TEST									
TEST ITEM	L		DCR	IDC		Q	HI-POT		
	S-F		S-F						
TEST COND	100KHz/0.25v		AT 25°C						
SPEC	6.3uH ±10%		70mΩ (Max)						
1	6.35		52.00						
2	6.40		53.00						
3	6.32		51.00						
4	6.38		49.00						
5	6.37		50.00						
6									
7									
8									
9									
10									
MAX	6.40		53.00						
MIN	6.32		49.00						
AVERAGE	6.36		51.00						
HRSW ELECTRONICS CO., LTD					PART NO				
					TITLE		G50单线圈开槽+背胶		
DRAWN BY			CHECKED BY			APPROVED BY			
Xie Chao			He weihua			Wei lihong			