



RADIO TEST REPORT

Test Report No. : 14113269H-A-R1

Applicant : DAIHATSU MOTOR CO., LTD.
Type of EUT : Keyfree system
Model Number of EUT : DH19C-1
FCC ID : 2AVSADH19C-1
Test regulation : FCC Part 15 Subpart C: 2021
Test Result : Complied (Refer to SECTION 3)

1. This test report shall not be reproduced in full or partial, without the written approval of UL Japan, Inc.
2. The results in this report apply only to the sample tested.
3. This sample tested is in compliance with the limits of the above regulation.
4. The test results in this test report are traceable to the national or international standards.
5. This test report must not be used by the customer to claim product certification, approval, or endorsement by the A2LA accreditation body.
6. This test report covers Radio technical requirements. It does not cover administrative issues such as Manual or non-Radio test related Requirements. (if applicable)
7. The all test items in this test report are conducted by UL Japan, Inc. Ise EMC Lab.
8. The opinions and the interpretations to the result of the description in this report are outside scopes where UL Japan has been accredited.
9. The information provided from the customer for this report is identified in SECTION 1.
10. This report is a revised version of 14113269H-A. 14113269H-A is replaced with this report.

Date of test: December 16, 2021 to January 30, 2022

Representative test engineer:

Hiroyuki Furutaka
Engineer

Approved by:

Tsubasa Takayama
Leader



CERTIFICATE 5107.02

- The testing in which "Non-accreditation" is displayed is outside the accreditation scopes in UL Japan.
 There is no testing item of "Non-accreditation".

UL Japan, Inc.
Ise EMC Lab.

4383-326 Asama-cho, Ise-shi, Mie-ken 516-0021 JAPAN
Telephone : +81 596 24 8999
Facsimile : +81 596 24 8124

REVISION HISTORY

Original Test Report No.: 14113269H-A

Revision	Test report No.	Date	Page revised	Contents
- (Original)	14113269H-A	January 14, 2022	-	-
1	14113269H-A-R1	February 2, 2022	P.1	Addition of test date due to additional test (Mode 7)).
1	14113269H-A-R1	February 2, 2022	P.8	Correction of Item name in Clause 3.3 From "99 % Occupied Band Width" to "99 % Occupied Bandwidth"
1	14113269H-A-R1	February 2, 2022	P.10	- Addition of mode 7) in Clause 4.1 - Addition of Remarks and note *1)
1	14113269H-A-R1	February 2, 2022	P.16, 17	Deletion of the unnecessary notation on data
1	14113269H-A-R1	February 2, 2022	P.22, 24, 27	Addition of test data due to additional test (Mode 7)).
1	14113269H-A-R1	February 2, 2022	P.28	Deletion of "MLPA-02" from Test equipment
1	14113269H-A-R1	February 2, 2022	P.29	Addition of Test equipment due to additional test (Mode 7)).

UL Japan, Inc.

Ise EMC Lab.

4383-326 Asama-cho, Ise-shi, Mie-ken 516-0021 JAPAN

Telephone : +81 596 24 8999

Facsimile : +81 596 24 8124

Reference: Abbreviations (Including words undescribed in this report)

A2LA	The American Association for Laboratory Accreditation	LIMS	Laboratory Information Management System
AC	Alternating Current	MCS	Modulation and Coding Scheme
AFH	Adaptive Frequency Hopping	MRA	Mutual Recognition Arrangement
AM	Amplitude Modulation	N/A	Not Applicable
Amp, AMP	Amplifier	NIST	National Institute of Standards and Technology
ANSI	American National Standards Institute	NS	No signal detect.
Ant, ANT	Antenna	NSA	Normalized Site Attenuation
AP	Access Point	OBW	Occupied BandWidth
ASK	Amplitude Shift Keying	OFDM	Orthogonal Frequency Division Multiplexing
Atten., ATT	Attenuator	P/M	Power meter
AV	Average	PCB	Printed Circuit Board
BPSK	Binary Phase-Shift Keying	PER	Packet Error Rate
BR	Bluetooth Basic Rate	PHY	Physical Layer
BT	Bluetooth	PK	Peak
BT LE	Bluetooth Low Energy	PN	Pseudo random Noise
BW	BandWidth	PRBS	Pseudo-Random Bit Sequence
Cal Int	Calibration Interval	PSD	Power Spectral Density
CCK	Complementary Code Keying	QAM	Quadrature Amplitude Modulation
Ch., CH	Channel	QP	Quasi-Peak
CISPR	Comite International Special des Perturbations Radioelectriques	QPSK	Quadrature Phase Shift Keying
CW	Continuous Wave	RBW	Resolution BandWidth
DBPSK	Differential BPSK	RDS	Radio Data System
DC	Direct Current	RE	Radio Equipment
D-factor	Distance factor	RF	Radio Frequency
DFS	Dynamic Frequency Selection	RMS	Root Mean Square
DQPSK	Differential QPSK	RNSS	Radio Navigation Satellite Service
DSSS	Direct Sequence Spread Spectrum	RSS	Radio Standards Specifications
DUT	Device Under Test	Rx	Receiving
EDR	Enhanced Data Rate	SA, S/A	Spectrum Analyzer
EIRP, e.i.r.p.	Equivalent Isotropically Radiated Power	SG	Signal Generator
EMC	ElectroMagnetic Compatibility	SVSWR	Site-Voltage Standing Wave Ratio
EMI	ElectroMagnetic Interference	TR, T/R	Test Receiver
EN	European Norm	Tx	Transmitting
ERP, e.r.p.	Effective Radiated Power	VBW	Video BandWidth
ETSI	European Telecommunications Standards Institute	Vert.	Vertical
EU	European Union	WLAN	Wireless LAN
EUT	Equipment Under Test		
Fac.	Factor		
FCC	Federal Communications Commission		
FHSS	Frequency Hopping Spread Spectrum		
FM	Frequency Modulation		
Freq.	Frequency		
FSK	Frequency Shift Keying		
GFSK	Gaussian Frequency-Shift Keying		
GNSS	Global Navigation Satellite System		
GPS	Global Positioning System		
Hori.	Horizontal		
ICES	Interference-Causing Equipment Standard		
IEC	International Electrotechnical Commission		
IEEE	Institute of Electrical and Electronics Engineers		
IF	Intermediate Frequency		
ILAC	International Laboratory Accreditation Conference		
ISED	Innovation, Science and Economic Development Canada		
ISO	International Organization for Standardization		
JAB	Japan Accreditation Board		
LAN	Local Area Network		

UL Japan, Inc.

Ise EMC Lab.

4383-326 Asama-cho, Ise-shi, Mie-ken 516-0021 JAPAN

Telephone : +81 596 24 8999

Facsimile : +81 596 24 8124

CONTENTS	PAGE
SECTION 1: Customer information.....	5
SECTION 2: Equipment under test (EUT).....	5
SECTION 3: Test specification, procedures & results.....	7
SECTION 4: Operation of EUT during testing	10
SECTION 5: Radiated emission (Fundamental and Spurious Emission)	12
SECTION 6: -20 dB Bandwidth.....	15
SECTION 7: 99% Bandwidth.....	15
APPENDIX 1: Test data	16
Radiated Emission (Fundamental and Spurious Emission).....	16
-20 dB Bandwidth / 99 % Occupied Bandwidth	24
APPENDIX 2: Test instruments	28
APPENDIX 3: Photographs of test setup	30
Radiated Spurious Emission.....	30
Worst Case Position	31

SECTION 1: Customer information

Company Name : DAIHATSU MOTOR CO., LTD.*
Address : 2-1-1, Momozono, Ikeda-shi, Osaka, 563-8651, Japan
Telephone Number : +81-72-754-5619
Contact Person : Kouji Ozawa

***Remarks:**

DAIHATSU MOTOR CO., LTD. designates DENSO CORPORATION and TOKAI RIKA CO., LTD. as manufacturer of the product (Keyfree system).

The information provided from the customer is as follows;

- Applicant, Type of EUT, Model Number of EUT, FCC ID on the cover and other relevant pages
- Operating/Test Mode(s) (Mode(s)) on all the relevant pages
- SECTION 1: Customer information
- SECTION 2: Equipment under test (EUT)
- SECTION 4: Operation of EUT during testing

* The laboratory is exempted from liability of any test results affected from the above information in SECTION 2 and 4.

SECTION 2: Equipment under test (EUT)

2.1. Identification of EUT

Type : Keyfree system
Model Number : DH19C-1
Serial Number : Refer to SECTION 4.2
Receipt Date : November 29, 2021
Condition : Production prototype
(Not for Sale: This sample is equivalent to mass-produced items.)
Modification : No Modification by the test lab.

2.2. Product Description

Model: DH19C-1 (referred to as the EUT in this report) is a Keyfree system.

General Specification

Rating : System:
DC 12.0 V
Internal:
DC 12.0 V (Transmitter)
DC 5.0 V (Receiver)
Clock Frequency (maximum) : 8 MHz (CPU)

Radio Specification

[Transmitter part]

Radio Type : LF Transmitter
Frequency of Operation : 125 kHz
Oscillator frequency : 4.0000 MHz (Ceramic)
Modulation : ASK (A1D)
Antenna type : LF Antenna (Outside Antenna D)
LF Antenna (Outside Antenna P)
LF Antenna (Outside Antenna B)
LF Antenna (Inside Antenna Fr)
LF Antenna (Inside Antenna Rr)
Immobilizer Antenna
Antenna Specification : LF antenna: Ferrite antenna coil
Immobilizer antenna: Loop antenna coil

[Receiver part]

Frequency of Operation : 433.92 MHz (Keyfree)
433.90 MHz (TPMS)
Oscillator frequency : 33.6 MHz (Crystal)
Intermediate frequency : 525 kHz (Keyfree)
1.05 MHz (TPMS)
Modulation : FSK (F1D)
Type of receiving system : Super-heterodyne
Antenna Specification : Internal antenna (Inverted F antenna)

SECTION 3: Test specification, procedures & results

3.1 Test Specification

Test Specification : FCC Part 15 Subpart C
FCC Part 15 final revised on May 3, 2021 and effective July 2, 2021

Title : FCC 47CFR Part15 Radio Frequency Device Subpart C Intentional Radiators
Section 15.207 Conducted limits
Section 15.209 Radiated emission limits; general requirements.

*Also the EUT complies with FCC Part 15 Subpart B.

3.2 Procedures and results

Item	Test Procedure	Specification	Remarks	Deviation	Worst margin	Results
Conducted Emission	<FCC> ANSI C63.10:2013 6 Standard test methods <ISED> RSS-Gen 8.8	<FCC> Section 15.207 <ISED> RSS-Gen 8.8	-	N/A	N/A	N/A *1)
Electric Field Strength of Fundamental Emission	<FCC> ANSI C63.10:2013 6 Standard test methods <ISED> RSS-Gen 6.5, 6.12	<FCC> Section 15.209 <ISED> RSS-210 7.2 RSS-Gen 8.9	Radiated	N/A	3.7 dB 125 kHz, 0 deg. Peak with Duty factor <Mode 5>	Complied a)
Electric Field Strength of Spurious Emission	<FCC> ANSI C63.10:2013 6 Standard test methods <ISED> RSS-Gen 6.5, 6.6, 6.13	<FCC> Section 15.209 <ISED> RSS-210 7.3 RSS-Gen 8.9	Radiated	N/A	3.1 dB 35.420 MHz, Vertical, QP <Mode 5>	Complied# a)
-20 dB Bandwidth	<FCC> ANSI C63.10:2013 6 Standard test methods <ISED> -	<FCC> Reference data <ISED> -	Radiated	N/A	N/A	Complied b)

Note: UL Japan, Inc.'s EMI Work Procedures No. 13-EM-W0420 and 13-EM-W0422.

*1) The test is not applicable since the EUT is not the device that is designed to be connected to the public utility (AC) power line.

a) Refer to APPENDIX 1 (data of Radiated emission)

b) Refer to APPENDIX 1 (data of -20 dB Bandwidth / 99 % Occupied Bandwidth)

Symbols:

Complied The data of this test item has enough margin, more than the measurement uncertainty.

Complied# The data of this test item meets the limits unless the measurement uncertainty is taken into consideration.

FCC Part 15.31 (e)

The battery voltage (DC 12V) is provided to the EUT. Input voltage to RF part does not go through the regulator. So the test was performed with the supply voltage varied between 85 % and 115% of the nominal rated supply voltage (DC 12 V) and the variation of the input power does not affect the test result, therefore the EUT complies with the requirement.

FCC Part 15.203 Antenna requirement

It is impossible for end users to replace the antenna, because the antenna is mounted inside of the vehicle. Therefore, the equipment complies with the antenna requirement of Section 15.203.

UL Japan, Inc.

Ise EMC Lab.

4383-326 Asama-cho, Ise-shi, Mie-ken 516-0021 JAPAN

Telephone : +81 596 24 8999

Facsimile : +81 596 24 8124

3.3 Addition to standard

Item	Test Procedure	Specification	Remarks	Deviation	Worst margin	Results
99 % Occupied Bandwidth	RSS-Gen 6.7	-	Radiated	N/A	N/A	-

Other than above, no addition, exclusion nor deviation has been made from the standard.

3.4 Uncertainty

There is no applicable rule of uncertainty in this applied standard. Therefore, the results are derived depending on whether or not laboratory uncertainty is applied.

The following uncertainties have been calculated to provide a confidence level of 95 % using a coverage factor $k=2$.

Test Item		Frequency range	Uncertainty (+/-)	
Radiated emission	3 m	9 kHz to 30 MHz	3.3 dB	
	10 m		3.2 dB	
	3 m	30 MHz to 200 MHz	(Horizontal)	4.8 dB
			(Vertical)	5.0 dB
		200 MHz to 1000 MHz	(Horizontal)	5.2 dB
			(Vertical)	6.3 dB
	10 m	30 MHz to 200 MHz	(Horizontal)	4.8 dB
			(Vertical)	4.8 dB
200 MHz to 1000 MHz		(Horizontal)	5.0 dB	
		(Vertical)	5.0 dB	
-20 dB Bandwidth / 99 % Occupied Bandwidth		-	0.96 %	

3.5 Test Location

UL Japan, Inc. Ise EMC Lab.

*A2LA Certificate Number: 5107.02 / FCC Test Firm Registration Number: 884919

ISED Lab Company Number: 2973C / CAB identifier: JP0002

4383-326 Asama-cho, Ise-shi, Mie-ken 516-0021 JAPAN

Telephone: +81 596 24 8999, Facsimile: +81 596 24 8124

Test site	Width x Depth x Height (m)	Size of reference ground plane (m) / horizontal conducting plane	Other rooms	Maximum measurement distance
No.1 semi-anechoic chamber	19.2 x 11.2 x 7.7	7.0 x 6.0	No.1 Power source room	10 m
No.2 semi-anechoic chamber	7.5 x 5.8 x 5.2	4.0 x 4.0	-	3 m
No.3 semi-anechoic chamber	12.0 x 8.5 x 5.9	6.8 x 5.75	No.3 Preparation room	3 m
No.3 shielded room	4.0 x 6.0 x 2.7	N/A	-	-
No.4 semi-anechoic chamber	12.0 x 8.5 x 5.9	6.8 x 5.75	No.4 Preparation room	3 m
No.4 shielded room	4.0 x 6.0 x 2.7	N/A	-	-
No.5 semi-anechoic chamber	6.0 x 6.0 x 3.9	6.0 x 6.0	-	-
No.5 measurement room	6.4 x 6.4 x 3.0	6.4 x 6.4	-	-
No.6 shielded room	4.0 x 4.5 x 2.7	4.0 x 4.5	-	-
No.6 measurement room	4.75 x 5.4 x 3.0	4.75 x 4.15	-	-
No.7 shielded room	4.7 x 7.5 x 2.7	4.7 x 7.5	-	-
No.8 measurement room	3.1 x 5.0 x 2.7	3.1 x 5.0	-	-
No.9 measurement room	8.8 x 4.6 x 2.8	2.4 x 2.4	-	-
No.10 shielded room	3.8 x 2.8 x 2.8	3.8 x 2.8	-	-
No.11 measurement room	4.0 x 3.4 x 2.5	N/A	-	-
No.12 measurement room	2.6 x 3.4 x 2.5	N/A	-	-

* Size of vertical conducting plane (for Conducted Emission test) : 2.0 x 2.0 m for No.1, No.2, No.3, and No.4 semi-anechoic chambers and No.3 and No.4 shielded rooms.

3.6 Test data, Test instruments, and Test set up

Refer to APPENDIX.

UL Japan, Inc.

Ise EMC Lab.

4383-326 Asama-cho, Ise-shi, Mie-ken 516-0021 JAPAN

Telephone : +81 596 24 8999

Facsimile : +81 596 24 8124

SECTION 4: Operation of EUT during testing

4.1. Operating Mode(s)

Test mode	Remarks *1)
1) Tx 125 kHz Outside Antenna D	Section 2 of Timing of transmission
2) Tx 125 kHz Outside Antenna P	Section 2 of Timing of transmission
3) Tx 125 kHz Outside Antenna B	Section 2 of Timing of transmission
4) Tx 125 kHz Inside Antenna Fr	Section 2 of Timing of transmission
5) Tx 125 kHz Inside Antenna Rr	Section 2 of Timing of transmission
6) Tx 125 kHz Immobilizer Antenna	Section 3 of Timing of transmission
7) Tx 125 kHz Outside Antenna D+P	Section 1 of Timing of transmission
* EUT was set by the software as follows; Software: 200213_RadioTest_TypeA.s Version - (Date: February 13, 2020, Storage location: EUT memory)	
*This setting of software is the worst case. Any conditions under the normal use do not exceed the condition of setting. In addition, end users cannot change the settings of the output power of the product.	

*1) Refer to Timing of transmission in “Theory of Operation” for details.

4.2. Configuration and peripherals

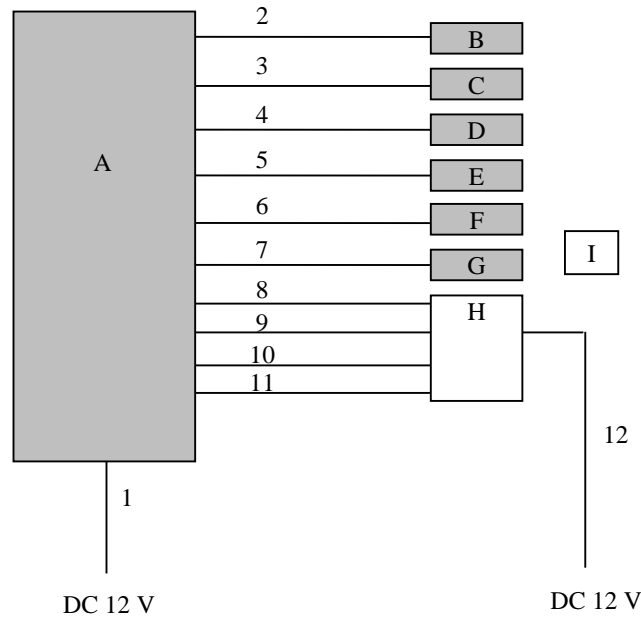

* Cabling and setup(s) were taken into consideration and test data was taken under worse case conditions.

** The input voltage (DC 12 V) passes through Item No. A without affecting it and is supplied to the antennas (Item No. G) without any drop in voltage.

For the antenna (Item No. B to F), a fixed voltage is supplied through the regulator.

Description of EUT and Support equipment

No.	Item	Model number	Serial number	Manufacturer	Remarks
A	Body ECU	DH19C-1	No.237	DENSO CORPORATION	EUT
B	Antenna	Outside Antenna D	No.237-1	TOKAI RIKA CO., LTD.	EUT
C	Antenna	Outside Antenna P	No.237-2	TOKAI RIKA CO., LTD.	EUT
D	Antenna	Outside Antenna B	No.237-3	TOKAI RIKA CO., LTD.	EUT
E	Antenna	Inside Antenna Fr	No.237-4	TOKAI RIKA CO., LTD.	EUT
F	Antenna	Inside Antenna Rr	No.237-5	TOKAI RIKA CO., LTD.	EUT
G	Antenna	Immobilizer Antenna	No.237	TOKAI RIKA CO., LTD.	EUT
H	Evaluation Bench	-	7	DENSO CORPORATION	-
I	Smart Key	-	237	DENSO CORPORATION	-

List of cables used

No.	Name	Length (m)	Shield		Remark
			Cable	Connector	
1	DC Cable	3.0	Unshielded	Unshielded	-
2	Antenna Cable (AND)	3.0	Unshielded	Unshielded	-
3	Antenna Cable (ANP)	3.0	Unshielded	Unshielded	-
4	Antenna Cable (ANB)	3.0	Unshielded	Unshielded	-
5	Antenna Cable (ANF)	3.0	Unshielded	Unshielded	-
6	Antenna Cable (ANR)	3.0	Unshielded	Unshielded	-
7	Antenna Cable	3.0	Unshielded	Unshielded	-
8	Signal Cable (CN-C)	3.0	Unshielded	Unshielded	-
9	Signal Cable (CN-K)	3.0	Unshielded	Unshielded	-
10	Signal Cable (CN-M)	3.0	Unshielded	Unshielded	-
11	Signal Cable (CN-P)	3.0	Unshielded	Unshielded	-
12	DC Cable	3.0	Unshielded	Unshielded	-

UL Japan, Inc.

Ise EMC Lab.

4383-326 Asama-cho, Ise-shi, Mie-ken 516-0021 JAPAN

Telephone : +81 596 24 8999

Facsimile : +81 596 24 8124

SECTION 5: Radiated emission (Fundamental and Spurious Emission)

Test Procedure

EUT was placed on a urethane platform of nominal size, 1.0 m by 1.5 m, raised 0.8 m above the conducting ground plane. The Radiated Electric Field Strength has been measured in a Semi Anechoic Chamber with a ground plane.

Frequency: From 9 kHz to 30 MHz

The EUT was rotated a full revolution in order to obtain the maximum value of the electric field intensity.

The measurements were performed for vertical polarization (antenna angle: 0 deg., 45 deg., 90 deg., and 135 deg.) and horizontal polarization.

*Refer to Figure 1 about Direction of the Loop Antenna.

Frequency: From 30 MHz to 1 GHz

The measuring antenna height varied between 1 and 4 m and EUT was rotated a full revolution in order to obtain the maximum value of the electric field intensity.

The measurements were performed for both vertical and horizontal antenna polarization.

The test was made with the detector (RBW/VBW) in the following table.

When using Spectrum analyzer, the test was made with adjusting span to zero by using peak hold.

Test Antennas are used as below;

Frequency	Below 30 MHz	30 MHz to 200 MHz	200 MHz to 1 GHz
Antenna Type	Loop	Biconical	Logperiodic

Frequency	From 9 kHz to 90 kHz and From 110 kHz to 150 kHz	From 90 kHz to 110 kHz	From 150 kHz to 490 kHz	From 490 kHz to 30 MHz	From 30 MHz to 1 GHz
Instrument used	Test Receiver				
Detector	PK / AV	QP	PK / AV	QP	QP
IF Bandwidth	200 Hz	200 Hz	9 kHz	9 kHz	120 kHz
Test Distance	3 m *1)	3 m *1)	3 m *1)	3 m *2)	3 m

*1) Distance Factor: $40 \times \log(3 \text{ m} / 300 \text{ m}) = -80 \text{ dB}$

*2) Distance Factor: $40 \times \log(3 \text{ m} / 30 \text{ m}) = -40 \text{ dB}$

Although these tests were performed other than open field test site, adequate comparison measurements were confirmed against 30 m open field test site. Therefore, sufficient tests were made to demonstrate that the alternative site produces results that correlate with the ones of tests made in an open field based on KDB 414788.

These tests were performed in semi anechoic chamber. Therefore, the measured level of emissions may be higher than if measurements were made without a ground plane.

However, test results were confirmed to pass against standard limit.

UL Japan, Inc.

Ise EMC Lab.

4383-326 Asama-cho, Ise-shi, Mie-ken 516-0021 JAPAN

Telephone : +81 596 24 8999

Facsimile : +81 596 24 8124

[Test Setup]
Below 1 GHz

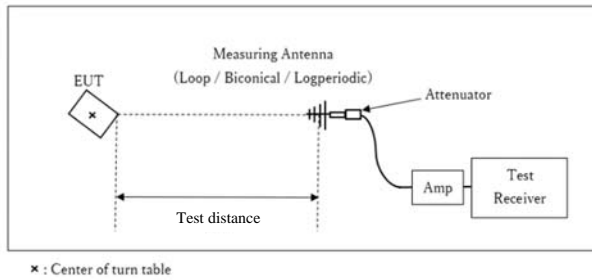

Test Distance: 3 m

- The carrier level and noise levels were confirmed at each position of X, Y and Z axes of EUT to see the position of maximum noise, and the test was made at the position that has the maximum noise.

This EUT has two modes which transponder key is attached or not. The worst case was confirmed with and without transponder key attached, as a result, the test without transponder key attached was the worst case. Therefore the test without transponder key attached was performed only.

The test results and limit are rounded off to one decimal place, so some differences might be observed.

Measurement range : 9 kHz - 1 GHz
Test data : APPENDIX
Test result : Pass

Figure 1: Direction of the Loop Antenna

Side View (Vertical)

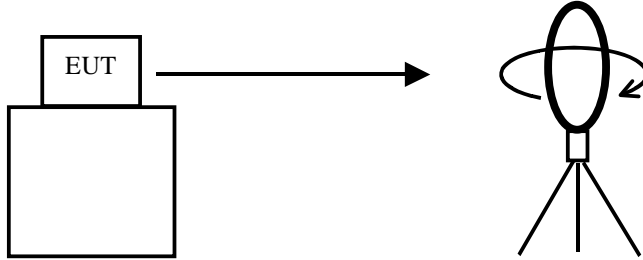

.....
Top View (Horizontal)

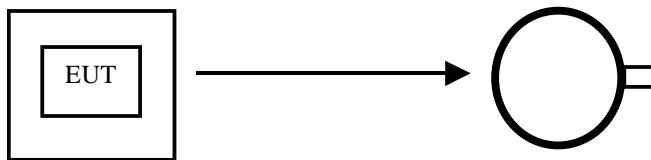

Antenna was not rotated.

.....

Top View (Vertical)

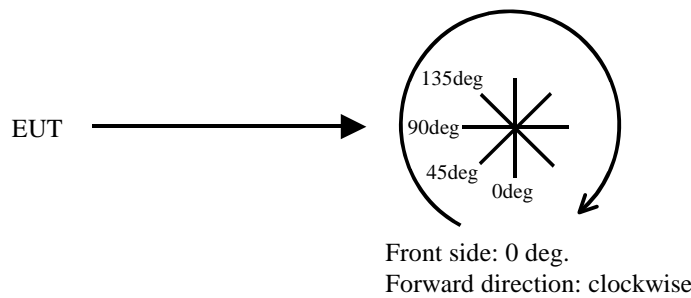

SECTION 6: -20 dB Bandwidth

Test Procedure

The test was measured with a spectrum analyzer using a test fixture.

Test	Span	RBW	VBW	Sweep	Detector	Trace	Instrument used
-20 dB Bandwidth	Enough width to display emission skirts	1 to 5 % of OBW	Three times of RBW	Auto	Peak	Max Hold	Spectrum Analyzer

Test data : APPENDIX 1

Test result : Pass

SECTION 7: 99% Bandwidth

Test Procedure

The test was measured with a spectrum analyzer using a test fixture.

Test	Span	RBW	VBW	Sweep	Detector	Trace	Instrument used
99 % Occupied Bandwidth	Enough width to display emission skirts	1 to 5 % of OBW	Three times of RBW	Auto	Peak *1)	Max Hold *1)	Spectrum Analyzer

*1) The measurement was performed with Peak detector, Max Hold since the duty cycle was not 100 %.
Peak hold was applied as Worst-case measurement.

Test data : APPENDIX

Test result : Pass

APPENDIX 1: Test data

Radiated Emission (Fundamental and Spurious Emission)

Report No. 14113269H
Test place Ise EMC Lab.
Semi Anechoic Chamber No.2 No.3
Date December 16, 2021 January 7, 2022
Temperature / Humidity 18 deg. C / 31 % RH 18 deg. C / 33 % RH
Engineer Hiroyuki Furutaka Nachi Konegawa
Mode Mode 1

PK or QP

Ant Deg [deg] or Polarity [Hori/Vert]	Frequency [MHz]	Detector	Reading [dBuV]	Ant Factor [dB/m]	Loss [dB]	Gain [dB]	Duty Factor [dB]	Result [dBuV/m]	Limit [dBuV/m]	Margin [dB]	Remark
0deg	0.12500	PK	108.3	18.9	-74.0	32.1	-	21.1	45.6	24.5	Fundamental (DC 10.2V)
0deg	0.12500	PK	108.3	18.9	-74.0	32.1	-	21.1	45.6	24.5	Fundamental (DC 12.0V)
0deg	0.12500	PK	108.3	18.9	-74.0	32.1	-	21.1	45.6	24.5	Fundamental (DC 13.8V)
0deg	0.25000	PK	55.5	18.8	-64.3	32.3	-	-22.3	39.6	61.9	
0deg	0.37500	PK	42.1	18.7	-64.3	32.3	-	-35.8	36.1	71.9	
0deg	0.50000	QP	29.7	18.7	-24.3	32.3	-	-8.2	33.6	41.8	
0deg	0.62500	QP	25.0	18.7	-24.3	32.4	-	-13.0	31.7	44.7	
0deg	0.75000	QP	23.5	18.7	-24.3	32.4	-	-14.5	30.1	44.6	
0deg	0.87500	QP	24.1	18.7	-24.3	32.4	-	-13.9	28.7	42.6	
0deg	1.00000	QP	22.4	18.7	-24.3	32.4	-	-15.6	27.6	43.2	
0deg	1.12500	QP	22.8	18.7	-24.3	32.4	-	-15.2	26.5	41.7	
0deg	1.25000	QP	22.5	18.7	-24.3	32.4	-	-15.5	25.6	41.1	
Hori.	76.615	QP	36.0	6.6	7.2	28.4	-	21.4	40.0	18.6	
Hori.	99.600	QP	40.1	10.2	7.5	28.3	-	29.5	43.5	14.0	
Hori.	118.234	QP	29.5	12.7	7.6	28.3	-	21.5	43.5	22.0	
Hori.	137.012	QP	28.9	14.3	7.7	28.2	-	22.7	43.5	20.8	
Hori.	290.500	QP	26.4	14.1	8.7	27.6	-	21.6	46.0	24.4	
Hori.	388.892	QP	28.5	15.8	9.5	28.3	-	25.5	46.0	20.5	
Vert.	32.185	QP	36.0	18.0	6.8	28.5	-	32.3	40.0	7.7	
Vert.	35.207	QP	29.3	16.9	6.8	28.5	-	24.5	40.0	15.5	
Vert.	64.000	QP	42.7	7.0	7.1	28.4	-	28.4	40.0	11.6	
Vert.	77.120	QP	39.7	6.6	7.3	28.4	-	25.2	40.0	14.8	
Vert.	102.607	QP	41.3	10.7	7.5	28.3	-	31.2	43.5	12.3	
Vert.	136.647	QP	31.7	14.3	7.7	28.2	-	25.5	43.5	18.0	

Result = Reading + Ant Factor + Loss (Cable + Attenuator + Filter + D.Factor) - Gain(Amplifier)

PK with Duty factor

Ant Deg [deg] or Polarity [Hori/Vert]	Frequency [MHz]	Detector	Reading [dBuV]	Ant Factor [dB/m]	Loss [dB]	Gain [dB]	Duty Factor [dB]	Result [dBuV/m]	Limit [dBuV/m]	Margin [dB]	Remark
0deg	0.12500	PK	108.3	18.9	-74.0	32.1	0.0	21.1	25.6	4.5	Fundamental (DC 10.2V)
0deg	0.12500	PK	108.3	18.9	-74.0	32.1	0.0	21.1	25.6	4.5	Fundamental (DC 12.0V)
0deg	0.12500	PK	108.3	18.9	-74.0	32.1	0.0	21.1	25.6	4.5	Fundamental (DC 13.8V)
0deg	0.25000	PK	55.5	18.8	-64.3	32.3	0.0	-22.3	19.6	41.9	
0deg	0.37500	PK	42.1	18.7	-64.3	32.3	0.0	-35.8	16.1	51.9	

Result = Reading + Ant Factor + Loss (Cable + Attenuator + Filter + D.Factor) - Gain(Amplifier) + Duty factor *

* Since the peak emission result satisfied the average limit, duty factor was omitted.

Result of the fundamental emission at 3 m without Distance factor

Ant Deg [deg]	Frequency [MHz]	Detector	Reading [dBuV]	Ant Factor [dB/m]	Loss [dB]	Gain [dB]	Duty Factor [dB]	Result [dBuV/m]	Limit [dBuV/m]	Margin [dB]	Remark
0deg	0.12500	PK	108.3	18.9	6.0	32.1	-	101.1	-	-	Fundamental

Result = Reading + Ant Factor + Loss (Cable+Attenuator) - Gain(Amplifier)

If Gain 0.0dB shown in the above table, pre-amplifier was not used to avoid the influence of carrier power. The pre-amplifier used for carrier frequency measurement was not saturated. Other frequency noises omitted in this report were not seen or had enough margin (more than 20 dB).

Radiated Emission (Fundamental and Spurious Emission)

Report No.	14113269H	
Test place	Ise EMC Lab.	
Semi Anechoic Chamber	No.2	No.3
Date	December 16, 2021	January 7, 2022
Temperature / Humidity	18 deg. C / 31 % RH	18 deg. C / 33 % RH
Engineer	Hiroyuki Furutaka	Nachi Konegawa
Mode	Mode 2	

PK or QP

Ant Deg [deg] or Polarity [Hori/Vert]	Frequency [MHz]	Detector	Reading [dBuV]	Ant Factor [dB/m]	Loss [dB]	Gain [dB]	Duty Factor [dB]	Result [dBuV/m]	Limit [dBuV/m]	Margin [dB]	Remark
Odeg	0.12500	PK	108.3	18.9	-74.0	32.1	-	21.1	45.6	24.5	Fundamental (DC 10.2V)
Odeg	0.12500	PK	108.3	18.9	-74.0	32.1	-	21.1	45.6	24.5	Fundamental (DC 12.0V)
Odeg	0.12500	PK	108.3	18.9	-74.0	32.1	-	21.1	45.6	24.5	Fundamental (DC 13.8V)
Odeg	0.25000	PK	55.0	18.8	-64.3	32.3	-	-22.8	39.6	62.4	
Odeg	0.37500	PK	42.1	18.7	-64.3	32.3	-	-35.8	36.1	71.9	
Odeg	0.50000	QP	28.7	18.7	-24.3	32.3	-	-9.2	33.6	42.8	
Odeg	0.62500	QP	24.5	18.7	-24.3	32.4	-	-13.5	31.7	45.2	
Odeg	0.75000	QP	23.4	18.7	-24.3	32.4	-	-14.6	30.1	44.7	
Odeg	0.87500	QP	23.4	18.7	-24.3	32.4	-	-14.6	28.7	43.3	
Odeg	1.00000	QP	22.4	18.7	-24.3	32.4	-	-15.6	27.6	43.2	
Odeg	1.12500	QP	22.7	18.7	-24.3	32.4	-	-15.3	26.5	41.8	
Odeg	1.25000	QP	22.3	18.7	-24.3	32.4	-	-15.7	25.6	41.3	
Hori.	77.134	QP	36.0	6.6	7.3	28.4	-	21.5	40.0	18.5	
Hori.	99.601	QP	40.2	10.2	7.5	28.3	-	29.6	43.5	13.9	
Hori.	118.368	QP	28.6	12.7	7.6	28.3	-	20.6	43.5	22.9	
Hori.	137.000	QP	28.7	14.3	7.7	28.2	-	22.5	43.5	21.0	
Hori.	293.241	QP	32.5	14.1	8.8	27.6	-	27.8	46.0	18.2	
Hori.	387.882	QP	29.9	15.8	9.5	28.3	-	26.9	46.0	19.1	
Vert.	32.185	QP	29.0	18.0	6.8	28.5	-	25.3	40.0	14.7	
Vert.	48.558	QP	30.2	11.9	6.9	28.4	-	20.6	40.0	19.4	
Vert.	69.260	QP	40.1	6.4	7.2	28.4	-	25.3	40.0	14.7	
Vert.	77.120	QP	39.7	6.6	7.3	28.4	-	25.2	40.0	14.8	
Vert.	101.602	QP	39.8	10.5	7.5	28.3	-	29.5	43.5	14.0	
Vert.	136.734	QP	34.6	14.3	7.7	28.2	-	28.4	43.5	15.1	

Result = Reading + Ant Factor + Loss (Cable + Attenuator + Filter + D.Factor) - Gain(Amplifier)

PK with Duty factor

Ant Deg [deg] or Polarity [Hori/Vert]	Frequency [MHz]	Detector	Reading [dBuV]	Ant Factor [dB/m]	Loss [dB]	Gain [dB]	Duty Factor [dB]	Result [dBuV/m]	Limit [dBuV/m]	Margin [dB]	Remark
Odeg	0.12500	PK	108.3	18.9	-74.0	32.1	0.0	21.1	25.6	4.5	Fundamental (DC 10.2V)
Odeg	0.12500	PK	108.3	18.9	-74.0	32.1	0.0	21.1	25.6	4.5	Fundamental (DC 12.0V)
Odeg	0.12500	PK	108.3	18.9	-74.0	32.1	0.0	21.1	25.6	4.5	Fundamental (DC 13.8V)
Odeg	0.25000	PK	55.0	18.8	-64.3	32.3	0.0	-22.8	19.6	42.4	
Odeg	0.37500	PK	42.1	18.7	-64.3	32.3	0.0	-35.8	16.1	51.9	

Result = Reading + Ant Factor + Loss (Cable + Attenuator + Filter + D.Factor) - Gain(Amplifier) + Duty factor *

* Since the peak emission result satisfied the average limit, duty factor was omitted.

Result of the fundamental emission at 3 m without Distance factor

Ant Deg [deg]	Frequency [MHz]	Detector	Reading [dBuV]	Ant Factor [dB/m]	Loss [dB]	Gain [dB]	Duty Factor [dB]	Result [dBuV/m]	Limit [dBuV/m]	Margin [dB]	Remark
Odeg	0.12500	PK	108.3	18.9	6.0	32.1	-	101.1	-	-	Fundamental

Result = Reading + Ant Factor + Loss (Cable+Attenuator) - Gain(Amplifier)

If Gain 0.0dB shown in the above table, pre-amplifier was not used to avoid the influence of carrier power. The pre-amplifier used for carrier frequency measurement was not saturated.
Other frequency noises omitted in this report were not seen or had enough margin (more than 20 dB).

UL Japan, Inc.

Ise EMC Lab.

4383-326 Asama-cho, Ise-shi, Mie-ken 516-0021 JAPAN

Telephone : +81 596 24 8999

Facsimile : +81 596 24 8124

Radiated Emission (Fundamental and Spurious Emission)

Report No.	14113269H	
Test place	Ise EMC Lab.	
Semi Anechoic Chamber	No.2	No.3
Date	December 16, 2021	January 7, 2022
Temperature / Humidity	18 deg. C / 31 % RH	18 deg. C / 33 % RH
Engineer	Hiroyuki Furutaka	Nachi Konegawa
Mode	Mode 3	

PK or QP

Ant Deg [deg] or Polarity [Hori/Vert]	Frequency [MHz]	Detector	Reading [dBuV]	Ant Factor [dB/m]	Loss [dB]	Gain [dB]	Duty Factor [dB]	Result [dBuV/m]	Limit [dBuV/m]	Margin [dB]	Remark
Odeg	0.12500	PK	109.0	18.9	-74.0	32.1	-	21.8	45.6	23.8	Fundamental (DC 10.2V)
Odeg	0.12500	PK	109.0	18.9	-74.0	32.1	-	21.8	45.6	23.8	Fundamental (DC 12.0V)
Odeg	0.12500	PK	109.0	18.9	-74.0	32.1	-	21.8	45.6	23.8	Fundamental (DC 13.8V)
Odeg	0.25000	PK	53.1	18.8	-64.3	32.3	-	-24.7	39.6	64.3	
Odeg	0.37500	PK	43.8	18.7	-64.3	32.3	-	-34.1	36.1	70.2	
Odeg	0.50000	QP	24.3	18.7	-24.3	32.3	-	-13.6	33.6	47.2	
Odeg	0.62500	QP	23.2	18.7	-24.3	32.4	-	-14.8	31.7	46.5	
Odeg	0.75000	QP	23.1	18.7	-24.3	32.4	-	-14.9	30.1	45.0	
Odeg	0.87500	QP	22.3	18.7	-24.3	32.4	-	-15.7	28.7	44.4	
Odeg	1.00000	QP	22.0	18.7	-24.3	32.4	-	-16.0	27.6	43.6	
Odeg	1.12500	QP	21.8	18.7	-24.3	32.4	-	-16.2	26.5	42.7	
Odeg	1.25000	QP	21.6	18.7	-24.3	32.4	-	-16.4	25.6	42.0	
Hori.	76.620	QP	35.6	6.6	7.2	28.4	-	21.0	40.0	19.0	
Hori.	100.599	QP	37.0	10.4	7.5	28.3	-	26.6	43.5	16.9	
Hori.	118.314	QP	29.3	12.7	7.6	28.3	-	21.3	43.5	22.2	
Hori.	137.011	QP	29.0	14.3	7.7	28.2	-	22.8	43.5	20.7	
Hori.	290.500	QP	30.1	14.1	8.7	27.6	-	25.3	46.0	20.7	
Hori.	383.886	QP	31.3	15.6	9.5	28.3	-	28.1	46.0	17.9	
Vert.	32.690	QP	31.3	17.8	6.8	28.5	-	27.4	40.0	12.6	
Vert.	37.219	QP	38.0	16.1	6.8	28.5	-	32.4	40.0	7.6	
Vert.	63.568	QP	42.8	7.1	7.1	28.4	-	28.6	40.0	11.4	
Vert.	77.120	QP	38.8	6.6	7.3	28.4	-	24.3	40.0	15.7	
Vert.	102.607	QP	41.5	10.7	7.5	28.3	-	31.4	43.5	12.1	
Vert.	131.725	QP	31.7	13.9	7.7	28.2	-	25.1	43.5	18.4	

Result = Reading + Ant Factor + Loss (Cable + Attenuator + Filter + D.Factor) - Gain(Amplifier)

PK with Duty factor

Ant Deg [deg] or Polarity [Hori/Vert]	Frequency [MHz]	Detector	Reading [dBuV]	Ant Factor [dB/m]	Loss [dB]	Gain [dB]	Duty Factor [dB]	Result [dBuV/m]	Limit [dBuV/m]	Margin [dB]	Remark
Odeg	0.12500	PK	109.0	18.9	-74.0	32.1	0.0	21.8	25.6	3.8	Fundamental (DC 10.2V)
Odeg	0.12500	PK	109.0	18.9	-74.0	32.1	0.0	21.8	25.6	3.8	Fundamental (DC 12.0V)
Odeg	0.12500	PK	109.0	18.9	-74.0	32.1	0.0	21.8	25.6	3.8	Fundamental (DC 13.8V)
Odeg	0.25000	PK	53.1	18.8	-64.3	32.3	0.0	-24.7	19.6	44.3	
Odeg	0.37500	PK	43.8	18.7	-64.3	32.3	0.0	-34.1	16.1	50.2	

Result = Reading + Ant Factor + Loss (Cable + Attenuator + Filter + D.Factor) - Gain(Amplifier) + Duty factor *

* Since the peak emission result satisfied the average limit, duty factor was omitted.

Result of the fundamental emission at 3 m without Distance factor

Ant Deg [deg]	Frequency [MHz]	Detector	Reading [dBuV]	Ant Factor [dB/m]	Loss [dB]	Gain [dB]	Duty Factor [dB]	Result [dBuV/m]	Limit [dBuV/m]	Margin [dB]	Remark
Odeg	0.12500	PK	109.0	18.9	6.0	32.1	-	101.8	-	-	Fundamental

Result = Reading + Ant Factor + Loss (Cable+Attenuator) - Gain(Amplifier)

If Gain 0.0dB shown in the above table, pre-amplifier was not used to avoid the influence of carrier power. The pre-amplifier used for carrier frequency measurement was not saturated.
Other frequency noises omitted in this report were not seen or had enough margin (more than 20 dB).

UL Japan, Inc.

Ise EMC Lab.

4383-326 Asama-cho, Ise-shi, Mie-ken 516-0021 JAPAN

Telephone : +81 596 24 8999

Facsimile : +81 596 24 8124

Radiated Emission (Fundamental and Spurious Emission)

Report No.	14113269H	
Test place	Ise EMC Lab.	
Semi Anechoic Chamber	No.2	No.3
Date	December 16, 2021	January 7, 2022
Temperature / Humidity	18 deg. C / 31 % RH	18 deg. C / 33 % RH
Engineer	Hiroyuki Furutaka	Nachi Konegawa
Mode	Mode 4	

PK or QP

Ant Deg [deg] or Polarity [Hori/Vert]	Frequency [MHz]	Detector	Reading [dBuV]	Ant Factor [dB/m]	Loss [dB]	Gain [dB]	Duty Factor [dB]	Result [dBuV/m]	Limit [dBuV/m]	Margin [dB]	Remark
0deg	0.12500	PK	108.2	18.9	-74.0	32.1	-	21.0	45.6	24.6	Fundamental (DC 10.2V)
0deg	0.12500	PK	108.2	18.9	-74.0	32.1	-	21.0	45.6	24.6	Fundamental (DC 12.0V)
0deg	0.12500	PK	108.2	18.9	-74.0	32.1	-	21.0	45.6	24.6	Fundamental (DC 13.8V)
0deg	0.25000	PK	55.7	18.8	-64.3	32.3	-	-22.1	39.6	61.7	
0deg	0.37500	PK	41.2	18.7	-64.3	32.3	-	-36.7	36.1	72.8	
0deg	0.50000	QP	29.1	18.7	-24.3	32.3	-	-8.8	33.6	42.4	
0deg	0.62500	QP	23.2	18.7	-24.3	32.4	-	-14.8	31.7	46.5	
0deg	0.75000	QP	23.0	18.7	-24.3	32.4	-	-15.0	30.1	45.1	
0deg	0.87500	QP	22.3	18.7	-24.3	32.4	-	-15.7	28.7	44.4	
0deg	1.00000	QP	22.0	18.7	-24.3	32.4	-	-16.0	27.6	43.6	
0deg	1.12500	QP	21.8	18.7	-24.3	32.4	-	-16.2	26.5	42.7	
0deg	1.25000	QP	21.2	18.7	-24.3	32.4	-	-16.8	25.6	42.4	
Hori.	76.600	QP	35.4	6.6	7.2	28.4	-	20.8	40.0	19.2	
Hori.	100.600	QP	37.5	10.4	7.5	28.3	-	27.1	43.5	16.4	
Hori.	119.716	QP	31.6	12.9	7.6	28.3	-	23.8	43.5	19.7	
Hori.	134.100	QP	29.2	14.1	7.7	28.2	-	22.8	43.5	20.7	
Hori.	292.519	QP	32.8	14.1	8.8	27.6	-	28.1	46.0	17.9	
Hori.	376.882	QP	30.4	15.4	9.4	28.2	-	27.0	46.0	19.0	
Vert.	33.838	QP	31.7	17.3	6.8	28.5	-	27.3	40.0	12.7	
Vert.	44.550	QP	34.4	13.4	6.9	28.4	-	26.3	40.0	13.7	
Vert.	63.600	QP	43.0	7.1	7.1	28.4	-	28.8	40.0	11.2	
Vert.	77.140	QP	41.3	6.6	7.3	28.4	-	26.8	40.0	13.2	
Vert.	102.607	QP	41.7	10.7	7.5	28.3	-	31.6	43.5	11.9	
Vert.	138.634	QP	32.6	14.3	7.8	28.2	-	26.5	43.5	17.0	

Result = Reading + Ant Factor + Loss (Cable + Attenuator + Filter + D.Factor) - Gain(Amplifier)

PK with Duty factor

Ant Deg [deg] or Polarity [Hori/Vert]	Frequency [MHz]	Detector	Reading [dBuV]	Ant Factor [dB/m]	Loss [dB]	Gain [dB]	Duty Factor [dB]	Result [dBuV/m]	Limit [dBuV/m]	Margin [dB]	Remark
0deg	0.12500	PK	108.2	18.9	-74.0	32.1	0.0	21.0	25.6	4.6	Fundamental (DC 10.2V)
0deg	0.12500	PK	108.2	18.9	-74.0	32.1	0.0	21.0	25.6	4.6	Fundamental (DC 12.0V)
0deg	0.12500	PK	108.2	18.9	-74.0	32.1	0.0	21.0	25.6	4.6	Fundamental (DC 13.8V)
0deg	0.25000	PK	55.7	18.8	-64.3	32.3	0.0	-22.1	19.6	41.7	
0deg	0.37500	PK	41.2	18.7	-64.3	32.3	0.0	-36.7	16.1	52.8	

Result = Reading + Ant Factor + Loss (Cable + Attenuator + Filter + D.Factor) - Gain(Amplifier) + Duty factor *

* Since the peak emission result satisfied the average limit, duty factor was omitted.

Result of the fundamental emission at 3 m without Distance factor

Ant Deg [deg]	Frequency [MHz]	Detector	Reading [dBuV]	Ant Factor [dB/m]	Loss [dB]	Gain [dB]	Duty Factor [dB]	Result [dBuV/m]	Limit [dBuV/m]	Margin [dB]	Remark
0deg	0.12500	PK	108.2	18.9	6.0	32.1	-	101.0	-	-	Fundamental

Result = Reading + Ant Factor + Loss (Cable+Attenuator) - Gain(Amplifier)

If Gain 0.0dB shown in the above table, pre-amplifier was not used to avoid the influence of carrier power. The pre-amplifier used for carrier frequency measurement was not saturated.
Other frequency noises omitted in this report were not seen or had enough margin (more than 20 dB).

UL Japan, Inc.

Ise EMC Lab.

4383-326 Asama-cho, Ise-shi, Mie-ken 516-0021 JAPAN

Telephone : +81 596 24 8999

Facsimile : +81 596 24 8124

Radiated Emission (Fundamental and Spurious Emission)

Report No.	14113269H	
Test place	Ise EMC Lab.	
Semi Anechoic Chamber	No.2	No.3
Date	December 16, 2021	January 7, 2022
Temperature / Humidity	18 deg. C / 31 % RH	18 deg. C / 33 % RH
Engineer	Hiroyuki Furutaka	Nachi Konegawa
Mode	Mode 5	

PK or QP

Ant Deg [deg] or Polarity [Hori/Vert]	Frequency [MHz]	Detector	Reading [dBuV]	Ant Factor [dB/m]	Loss [dB]	Gain [dB]	Duty Factor [dB]	Result [dBuV/m]	Limit [dBuV/m]	Margin [dB]	Remark
Odeg	0.12500	PK	109.1	18.9	-74.0	32.1	-	21.9	45.6	23.7	Fundamental (DC 10.2V)
Odeg	0.12500	PK	109.1	18.9	-74.0	32.1	-	21.9	45.6	23.7	Fundamental (DC 12.0V)
Odeg	0.12500	PK	109.1	18.9	-74.0	32.1	-	21.9	45.6	23.7	Fundamental (DC 13.8V)
Odeg	0.25000	PK	53.7	18.8	-64.3	32.3	-	-24.1	39.6	63.7	
Odeg	0.37500	PK	46.1	18.7	-64.3	32.3	-	-31.8	36.1	67.9	
Odeg	0.50000	QP	33.2	18.7	-24.3	32.3	-	-4.7	33.6	38.3	
Odeg	0.62500	QP	29.0	18.7	-24.3	32.4	-	-9.0	31.7	40.7	
Odeg	0.75000	QP	23.3	18.7	-24.3	32.4	-	-14.7	30.1	44.8	
Odeg	0.87500	QP	22.8	18.7	-24.3	32.4	-	-15.2	28.7	43.9	
Odeg	1.00000	QP	22.0	18.7	-24.3	32.4	-	-16.0	27.6	43.6	
Odeg	1.12500	QP	22.8	18.7	-24.3	32.4	-	-15.2	26.5	41.7	
Odeg	1.25000	QP	22.4	18.7	-24.3	32.4	-	-15.6	25.6	41.2	
Hori.	77.139	QP	36.1	6.6	7.3	28.4	-	21.6	40.0	18.4	
Hori.	99.601	QP	38.8	10.2	7.5	28.3	-	28.2	43.5	15.3	
Hori.	119.716	QP	32.0	12.9	7.6	28.3	-	24.2	43.5	19.3	
Hori.	138.223	QP	29.6	14.3	7.7	28.2	-	23.4	43.5	20.1	
Hori.	292.534	QP	32.6	14.1	8.8	27.6	-	27.9	46.0	18.1	
Hori.	390.895	QP	31.0	15.9	9.5	28.3	-	28.1	46.0	17.9	
Vert.	32.192	QP	35.4	18.0	6.8	28.5	-	31.7	40.0	8.3	
Vert.	35.420	QP	41.8	16.8	6.8	28.5	-	36.9	40.0	3.1	
Vert.	63.568	QP	42.1	7.1	7.1	28.4	-	27.9	40.0	12.1	
Vert.	75.622	QP	40.7	6.5	7.2	28.4	-	26.0	40.0	14.0	
Vert.	101.602	QP	39.7	10.5	7.5	28.3	-	29.4	43.5	14.1	
Vert.	133.453	QP	33.6	14.0	7.7	28.2	-	27.1	43.5	16.4	

Result = Reading + Ant Factor + Loss (Cable + Attenuator + Filter + D.Factor) - Gain(Amplifier)

PK with Duty factor

Ant Deg [deg] or Polarity [Hori/Vert]	Frequency [MHz]	Detector	Reading [dBuV]	Ant Factor [dB/m]	Loss [dB]	Gain [dB]	Duty Factor [dB]	Result [dBuV/m]	Limit [dBuV/m]	Margin [dB]	Remark
Odeg	0.12500	PK	109.1	18.9	-74.0	32.1	0.0	21.9	25.6	3.7	Fundamental (DC 10.2V)
Odeg	0.12500	PK	109.1	18.9	-74.0	32.1	0.0	21.9	25.6	3.7	Fundamental (DC 12.0V)
Odeg	0.12500	PK	109.1	18.9	-74.0	32.1	0.0	21.9	25.6	3.7	Fundamental (DC 13.8V)
Odeg	0.25000	PK	53.7	18.8	-64.3	32.3	0.0	-24.1	19.6	43.7	
Odeg	0.37500	PK	46.1	18.7	-64.3	32.3	0.0	-31.8	16.1	47.9	

Result = Reading + Ant Factor + Loss (Cable + Attenuator + Filter + D.Factor) - Gain(Amplifier) + Duty factor *

* Since the peak emission result satisfied the average limit, duty factor was omitted.

Result of the fundamental emission at 3 m without Distance factor

Ant Deg [deg]	Frequency [MHz]	Detector	Reading [dBuV]	Ant Factor [dB/m]	Loss [dB]	Gain [dB]	Duty Factor [dB]	Result [dBuV/m]	Limit [dBuV/m]	Margin [dB]	Remark
Odeg	0.12500	PK	109.1	18.9	6.0	32.1	-	101.9	-	-	Fundamental

Result = Reading + Ant Factor + Loss (Cable+Attenuator) - Gain(Amplifier)

If Gain 0.0dB shown in the above table, pre-amplifier was not used to avoid the influence of carrier power. The pre-amplifier used for carrier frequency measurement was not saturated.
Other frequency noises omitted in this report were not seen or had enough margin (more than 20 dB).

Radiated Emission (Fundamental and Spurious Emission)

Report No. 14113269H
Test place Ise EMC Lab.
Semi Anechoic Chamber No.2
Date December 16, 2021
Temperature / Humidity 18 deg. C / 31 % RH
Engineer Hiroyuki Furutaka
Mode Mode 6

PK or QP

Ant Deg [deg] or Polarity [Hori/Vert]	Frequency [MHz]	Detector	Reading [dBuV]	Ant Factor [dB/m]	Loss [dB]	Gain [dB]	Duty Factor [dB]	Result [dBuV/m]	Limit [dBuV/m]	Margin [dB]	Remark
Odeg	0.12500	PK	91.8	18.9	-74.0	32.1	-	4.6	45.6	41.0	Fundamental (DC 10.2V)
Odeg	0.12500	PK	91.8	18.9	-74.0	32.1	-	4.6	45.6	41.0	Fundamental (DC 12.0V)
Odeg	0.12500	PK	91.8	18.9	-74.0	32.1	-	4.6	45.6	41.0	Fundamental (DC 13.8V)
Odeg	0.25000	PK	46.0	18.9	-73.9	32.1	-	-41.1	39.6	80.7	
Odeg	0.37500	PK	54.9	18.8	-73.9	32.1	-	-32.3	36.1	68.4	
Odeg	0.50000	QP	33.4	18.8	-33.9	32.0	-	-13.7	33.6	47.3	
Odeg	0.62500	QP	44.0	18.8	-33.9	32.1	-	-3.2	31.7	34.9	
Odeg	0.75000	QP	32.2	18.8	-33.8	32.1	-	-14.9	30.1	45.0	
Odeg	0.87500	QP	39.0	18.8	-33.8	32.1	-	-8.1	28.7	36.8	
Odeg	1.00000	QP	31.7	18.8	-33.8	32.2	-	-15.5	27.6	43.1	
Odeg	1.12500	QP	36.0	18.8	-33.8	32.2	-	-11.2	26.5	37.7	
Odeg	1.25000	QP	31.6	18.8	-33.8	32.2	-	-15.6	25.6	41.2	
Hori.	108.197	QP	19.2	11.5	7.5	28.3	-	9.9	43.5	33.6	
Hori.	116.112	QP	24.6	12.5	7.6	28.3	-	16.4	43.5	27.1	
Hori.	136.029	QP	18.8	14.2	7.7	28.2	-	12.5	43.5	31.0	
Hori.	164.346	QP	18.8	15.6	7.9	28.1	-	14.2	43.5	29.3	
Hori.	284.284	QP	27.7	14.2	8.7	27.7	-	22.9	46.0	23.1	
Hori.	404.401	QP	28.7	16.4	9.6	28.5	-	26.2	46.0	19.8	
Vert.	108.105	QP	29.5	11.5	7.5	28.3	-	20.2	43.5	23.3	
Vert.	116.112	QP	28.1	12.5	7.6	28.3	-	19.9	43.5	23.6	
Vert.	136.139	QP	22.8	14.2	7.7	28.2	-	16.5	43.5	27.0	
Vert.	164.160	QP	26.0	15.6	7.9	28.1	-	21.4	43.5	22.1	
Vert.	228.231	QP	27.7	12.4	8.3	27.8	-	20.6	46.0	25.4	
Vert.	396.391	QP	26.9	16.2	9.6	28.4	-	24.3	46.0	21.7	

Result = Reading + Ant Factor + Loss (Cable + Attenuator + D.Factor) - Gain(Amplifier)

PK with Duty factor

Ant Deg [deg] or Polarity [Hori/Vert]	Frequency [MHz]	Detector	Reading [dBuV]	Ant Factor [dB/m]	Loss [dB]	Gain [dB]	Duty Factor [dB]	Result [dBuV/m]	Limit [dBuV/m]	Margin [dB]	Remark
Odeg	0.12500	PK	91.8	18.9	-74.0	32.1	0.0	4.6	25.6	21.0	Fundamental (DC 10.2V)
Odeg	0.12500	PK	91.8	18.9	-74.0	32.1	0.0	4.6	25.6	21.0	Fundamental (DC 12.0V)
Odeg	0.12500	PK	91.8	18.9	-74.0	32.1	0.0	4.6	25.6	21.0	Fundamental (DC 13.8V)
Odeg	0.25000	PK	46.0	18.9	-73.9	32.1	0.0	-41.1	19.6	60.7	
Odeg	0.37500	PK	54.9	18.8	-73.9	32.1	0.0	-32.3	16.1	48.4	

Result = Reading + Ant Factor + Loss (Cable + Attenuator + D.Factor) - Gain(Amplifier) + Duty factor *

* Since the peak emission result satisfied the average limit, duty factor was omitted.

Result of the fundamental emission at 3 m without Distance factor

Ant Deg [deg]	Frequency [MHz]	Detector	Reading [dBuV]	Ant Factor [dB/m]	Loss [dB]	Gain [dB]	Duty Factor [dB]	Result [dBuV/m]	Limit [dBuV/m]	Margin [dB]	Remark
Odeg	0.12500	PK	91.8	18.9	6.0	32.1	-	84.6	-	-	Fundamental

Result = Reading + Ant Factor + Loss (Cable+Attenuator) - Gain(Amplifier)

If Gain 0.0dB shown in the above table, pre-amplifier was not used to avoid the influence of carrier power. The pre-amplifier used for carrier frequency measurement was not saturated.
Other frequency noises omitted in this report were not seen or had enough margin (more than 20 dB).

UL Japan, Inc.

Ise EMC Lab.

4383-326 Asama-cho, Ise-shi, Mie-ken 516-0021 JAPAN

Telephone : +81 596 24 8999

Facsimile : +81 596 24 8124

Radiated Emission (Fundamental and Spurious Emission)

Report No. 14113269H
Test place Ise EMC Lab.
Semi Anechoic Chamber No.4
Date January 30, 2022
Temperature / Humidity 21 deg. C / 35 % RH
Engineer Yuta Moriya
Mode Mode 7

PK or QP

Ant Deg [deg] or Polarity [Hori/Vert]	Frequency [MHz]	Detector	Reading [dBuV]	Ant Factor [dB/m]	Loss [dB]	Gain [dB]	Duty Factor [dB]	Result [dBuV/m]	Limit [dBuV/m]	Margin [dB]	Remark
Odeg	0.12500	PK	100.6	18.9	-73.8	32.3	-	13.4	45.6	32.2	Fundamental (DC 10.2V)
Odeg	0.12500	PK	100.6	18.9	-73.8	32.3	-	13.4	45.6	32.2	Fundamental (DC 12.0V)
Odeg	0.12500	PK	100.6	18.9	-73.8	32.3	-	13.4	45.6	32.2	Fundamental (DC 13.8V)
Odeg	0.25000	PK	47.2	18.9	-64.0	32.3	-	-30.2	39.6	69.8	
Odeg	0.37500	PK	62.2	18.8	-64.1	32.3	-	-15.4	36.1	51.5	
Odeg	0.50000	QP	25.7	18.8	-24.1	32.3	-	-11.9	33.6	45.5	
Odeg	0.62500	QP	44.7	18.8	-24.1	32.4	-	7.0	31.7	24.7	
Odeg	0.75000	QP	23.0	18.8	-24.1	32.4	-	-14.7	30.1	44.8	
Odeg	0.87500	QP	38.1	18.8	-24.1	32.4	-	0.4	28.7	28.3	
Odeg	1.00000	QP	22.2	18.8	-24.1	32.4	-	-15.5	27.6	43.1	
Odeg	1.12500	QP	34.7	18.8	-24.1	32.4	-	-3.0	26.5	29.5	
Odeg	1.25000	QP	21.8	18.8	-24.1	32.4	-	-15.9	25.6	41.5	
Hori.	34.468	QP	21.3	17.0	7.1	32.0	-	13.4	40.0	26.6	
Hori.	60.598	QP	32.4	7.7	7.4	32.0	-	15.5	40.0	24.5	
Hori.	102.758	QP	21.4	10.7	7.9	32.0	-	8.0	43.5	35.5	
Hori.	148.664	QP	21.5	15.0	8.3	32.0	-	12.8	43.5	30.7	
Hori.	243.196	QP	29.0	11.8	9.0	31.9	-	17.9	46.0	28.1	
Hori.	443.076	QP	27.6	16.5	10.3	32.0	-	22.4	46.0	23.6	
Vert.	34.468	QP	25.1	17.0	7.1	32.0	-	17.2	40.0	22.8	
Vert.	60.598	QP	32.6	7.7	7.4	32.0	-	15.7	40.0	24.3	
Vert.	102.758	QP	27.6	10.7	7.9	32.0	-	14.2	43.5	29.3	
Vert.	148.664	QP	31.0	15.0	8.3	32.0	-	22.3	43.5	21.2	
Vert.	244.220	QP	36.2	11.8	9.0	31.9	-	25.1	46.0	20.9	
Vert.	443.076	QP	21.0	16.5	10.3	32.0	-	15.8	46.0	30.2	

Result = Reading + Ant Factor + Loss (Cable + Attenuator + Filter + D.Factor) - Gain(Amplifier)

PK with Duty factor

Ant Deg [deg] or Polarity [Hori/Vert]	Frequency [MHz]	Detector	Reading [dBuV]	Ant Factor [dB/m]	Loss [dB]	Gain [dB]	Duty Factor [dB]	Result [dBuV/m]	Limit [dBuV/m]	Margin [dB]	Remark
Odeg	0.12500	PK	100.6	18.9	-73.8	32.3	0.0	13.4	25.6	12.2	Fundamental (DC 10.2V)
Odeg	0.12500	PK	100.6	18.9	-73.8	32.3	0.0	13.4	25.6	12.2	Fundamental (DC 12.0V)
Odeg	0.12500	PK	100.6	18.9	-73.8	32.3	0.0	13.4	25.6	12.2	Fundamental (DC 13.8V)
Odeg	0.25000	PK	47.2	18.9	-64.0	32.3	0.0	-30.2	19.6	49.8	
Odeg	0.37500	PK	62.2	18.8	-64.1	32.3	0.0	-15.4	16.1	31.5	

Result = Reading + Ant Factor + Loss (Cable + Attenuator + Filter + D.Factor) - Gain(Amplifier) + Duty factor *

* Since the peak emission result satisfied the average limit, duty factor was omitted.

Result of the fundamental emission at 3 m without Distance factor

Ant Deg [deg]	Frequency [MHz]	Detector	Reading [dBuV]	Ant Factor [dB/m]	Loss [dB]	Gain [dB]	Duty Factor [dB]	Result [dBuV/m]	Limit [dBuV/m]	Margin [dB]	Remark
Odeg	0.12500	PK	100.6	18.9	6.2	32.3	-	93.4	-	-	Fundamental

Result = Reading + Ant Factor + Loss (Cable+Attenuator) - Gain(Amplifier)

If Gain 0.0dB shown in the above table, pre-amplifier was not used to avoid the influence of carrier power. The pre-amplifier used for carrier frequency measurement was not saturated.
Other frequency noises omitted in this report were not seen or had enough margin (more than 20 dB).

UL Japan, Inc.

Ise EMC Lab.

4383-326 Asama-cho, Ise-shi, Mie-ken 516-0021 JAPAN

Telephone : +81 596 24 8999

Facsimile : +81 596 24 8124

Radiated Spurious Emission
(Plot data, Worst case for Spurious Emission)

Report No.	14113269H	No.3
Test place	Ise EMC Lab.	January 7, 2022
Semi Anechoic Chamber	No.2	
Date	December 16, 2021	18 deg. C / 33 % RH
Temperature / Humidity	18 deg. C / 31 % RH	18 deg. C / 33 % RH
Engineer	Hiroyuki Furutaka	Nachi Konegawa
Mode	Mode 5	

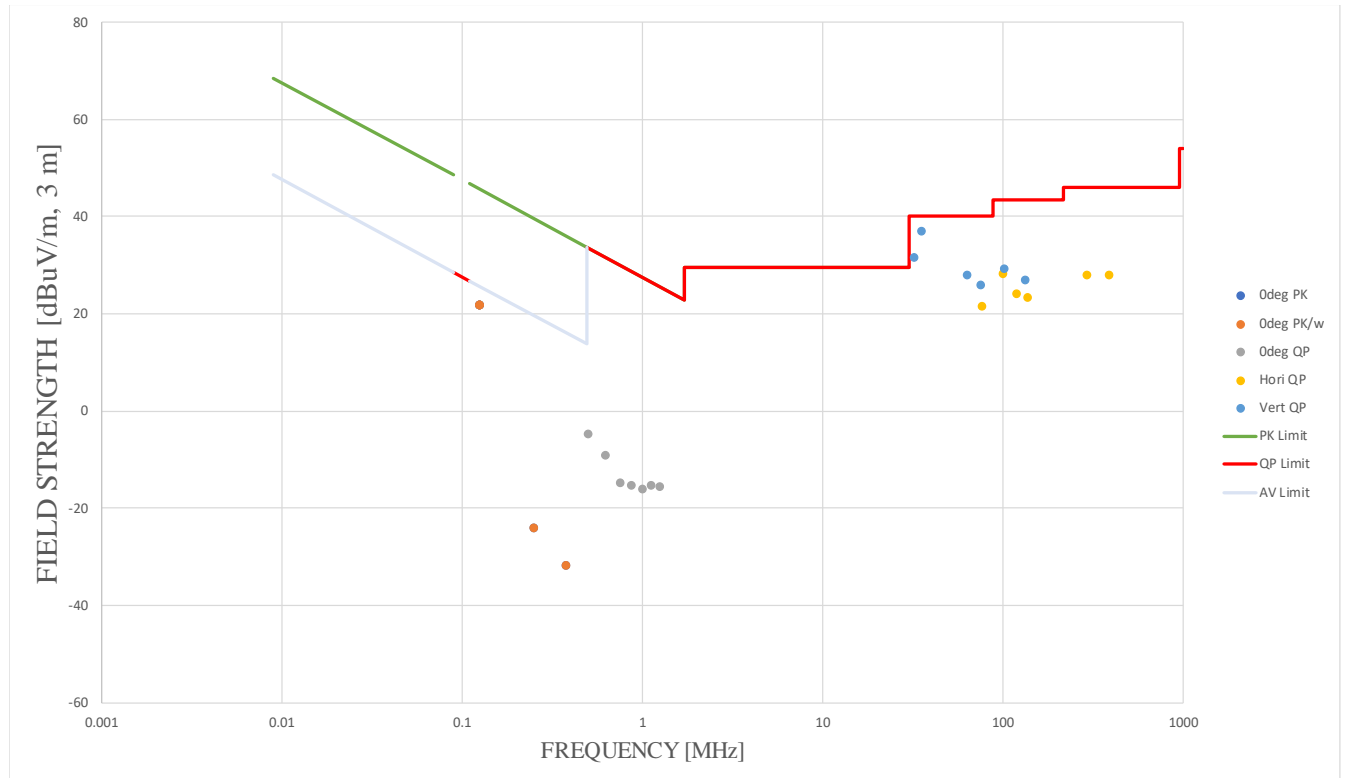

-20 dB Bandwidth / 99 % Occupied Bandwidth

Report No.	14113269H		
Test place	Ise EMC Lab.		
Semi Anechoic Chamber	No.2	No.3	No.4
Date	December 16, 2021	January 7, 2022	January 30, 2022
Temperature / Humidity	18 deg. C / 31 % RH	18 deg. C / 33 % RH	21 deg. C / 35 % RH
Engineer	Hiroyuki Furutaka	Nachi Konegawa	Yuta Moriya
Mode	Tx 125kHz		

Mode	-20 dB Bandwidth [kHz]	99 % Occupied Bandwidth [kHz]
1) Outside Antenna D	10.666	23.1900
2) Outside Antenna P	10.574	22.7989
3) Outside Antenna B	10.214	16.6797
4) Inside Antenna Fr	16.855	22.1895
5) Inside Antenna Rr	10.298	16.6826
6) Immobilizer Antenna (With transponder key attached)	17.755	34.4453
Immobilizer Antenna (Without transponder key attached)	10.408	21.8549
7) Outside Antenna D+P	24.398	32.4049

-20 dB Bandwidth / 99 % Occupied Bandwidth

Report No.	14113269H
Test place	Ise EMC Lab.
Semi Anechoic Chamber	No.2
Date	December 16, 2021
Temperature / Humidity	18 deg. C / 31 % RH
Engineer	Hiroyuki Furutaka
Mode	Mode 1 to 6

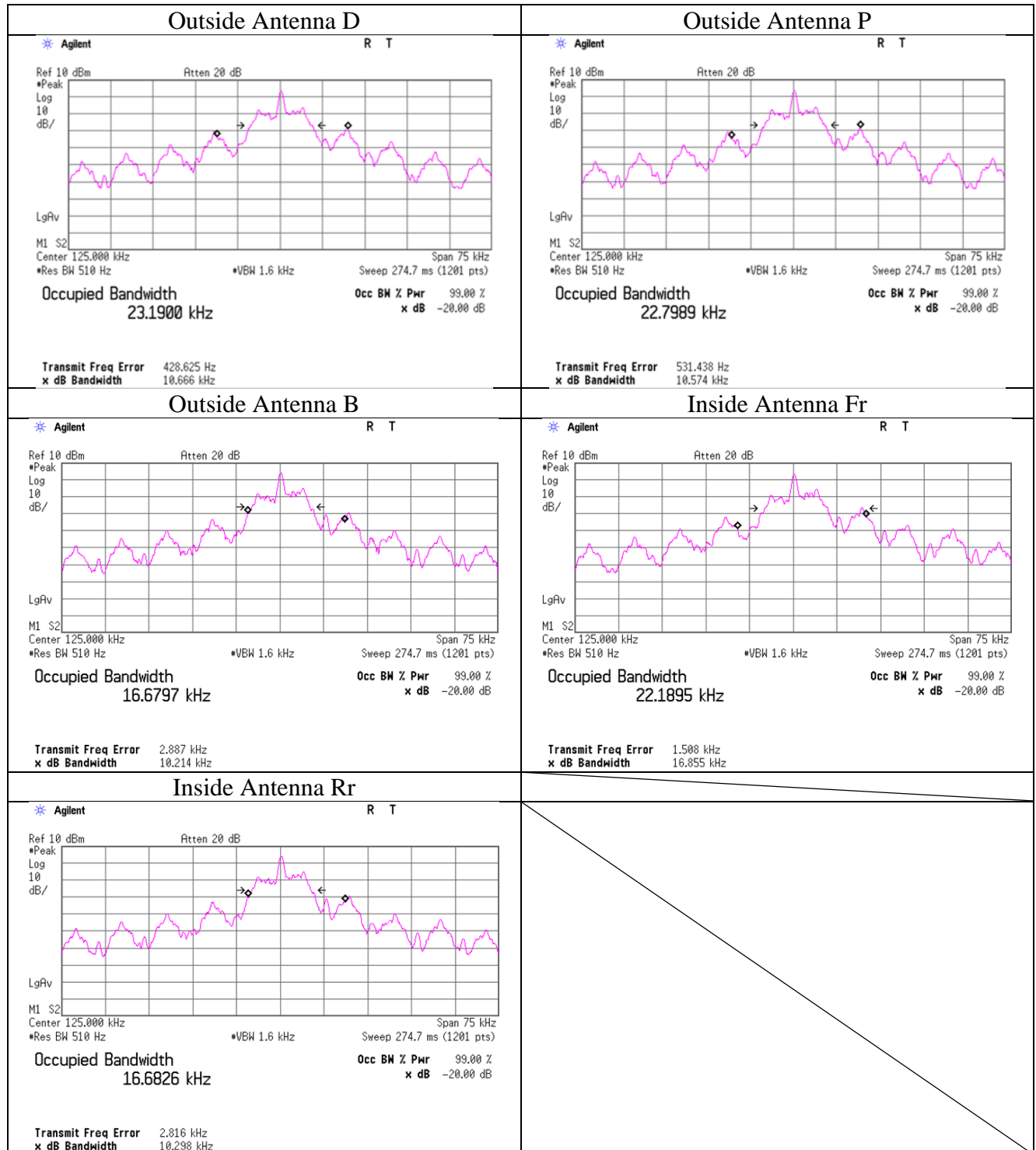

-20 dB Bandwidth / 99 % Occupied Bandwidth

Report No.	14113269H	No.3
Test place	Ise EMC Lab.	January 7, 2022
Semi Anechoic Chamber	No.2	18 deg. C / 33 % RH
Date	December 16, 2021	18 deg. C / 33 % RH
Temperature / Humidity	18 deg. C / 31 % RH	Nachi Konegawa
Engineer	Hiroyuki Furutaka	Mode 1 to 6
Mode	Mode 1 to 6	

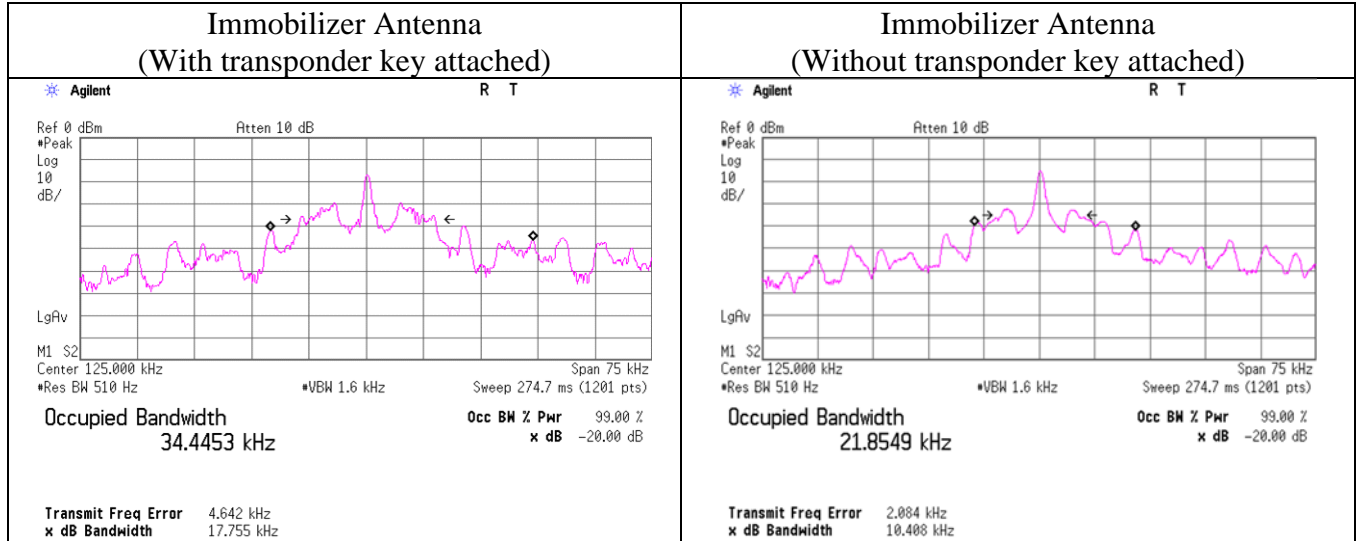

-20 dB Bandwidth / 99 % Occupied Bandwidth

Report No. 14113269H
Test place Ise EMC Lab.
Semi Anechoic Chamber No.4
Date January 30, 2022
Temperature / Humidity 21 deg. C / 35 % RH
Engineer Yuta Moriya
Mode Mode 7

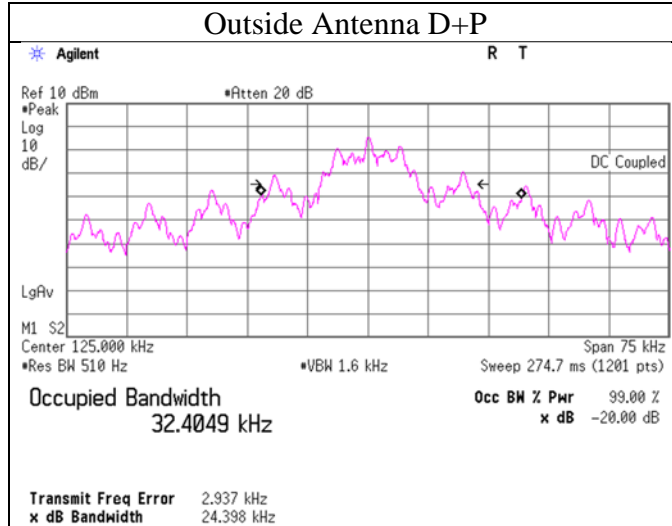

APPENDIX 2: Test instruments

Test equipment (Tested on December 16, 2021 and January 7, 2022)

Test Item	Local ID	LIMS ID	Description	Manufacturer	Model	Serial	Last Calibration Date	Cal Int
RE	MAEC-02	142004	AC2_Semi Anechoic Chamber(NSA)	TDK	Semi Anechoic Chamber 3m	DA-06902	05/26/2020	24
RE	MOS-41	192300	Thermo-Hygrometer	CUSTOM. Inc	CTH-201	0013	12/19/2021	12
RE	MMM-01	141542	Digital Tester	Fluke Corporation	FLUKE 26-3	78030611	08/10/2021	12
RE	MJM-27	142228	Measure	KOMELON	KMC-36	-	-	-
RE	COTS-MEMI-02	178648	EMI measurement program	TSJ (Techno Science Japan)	TEPTO-DV	-	-	-
RE	MAT-07	141203	Attenuator(6dB)	Weinschel Corp	2	BK7970	11/09/2021	12
RE	MBA-08	141427	Biconical Antenna	Schwarzbeck Mess-Elektronik OHG	VHA9103B+ BBA9106	08031	07/10/2021	12
RE	MCC-12	141317	Coaxial Cable	UL Japan Inc.	-	-	09/06/2021	12
RE	MLA-21	141265	Logperiodic Antenna (200-1000MHz)	Schwarzbeck Mess-Elektronik OHG	VUSLP9111B	9111B-190	07/10/2021	12
RE	MPA-24	141594	Pre Amplifier	Keysight Technologies Inc	8447D	2944A10150	02/18/2021	12
RE	MTR-10	141951	EMI Test Receiver	Rohde & Schwarz	ESR26	101408	03/09/2021	12
RE	MCC-13	141222	Coaxial Cable	Fujikura,HP,Mini-Circuits,Fujikura	3D-2W(12m)/5D-2W(5m)/5D-2W(0.8m)/5D-2W(1m)	-	02/18/2021	12
RE	MLPA-01	141254	Loop Antenna	Rohde & Schwarz	HFH2-Z2	100017	04/17/2021	12
RE	MCC-255	207745	Coaxial Cable	UL Japan Inc.	-	-	05/17/2021	12
RE	MPA-14	141583	Pre Amplifier	SONOMA INSTRUMENT	310	260833	02/18/2021	12
RE	MSA-04	141885	Spectrum Analyzer	Keysight Technologies Inc	E4448A	US44300523	11/10/2021	12
RE	MAEC-03	142008	AC3_Semi Anechoic Chamber(NSA)	TDK	Semi Anechoic Chamber 3m	DA-10005	05/22/2020	24
RE	MOS-13	141554	Thermo-Hygrometer	CUSTOM. Inc	CTH-201	1301	01/15/2021	12
RE	MMM-08	141532	DIGITAL HiTESTER	HIOKI E.E. CORPORATION	3805	51201197	01/07/2021	12
RE	MJM-16	142183	Measure	KOMELON	KMC-36	-	-	-
RE	MTR-03	141942	Test Receiver	Rohde & Schwarz	ESCI	100300	08/05/2021	12
RE	MCC-64	141327	Coaxial Cable	UL Japan	-	-	02/03/2021	12
RE	MAT-95	142314	Attenuator	Pasternack Enterprises	PE7390-6	D/C 1504	06/09/2021	12
RE	MHF-24	141295	High Pass Filter 0.15-30MHz	Rohde & Schwarz	EZ-25/3	100041	02/18/2021	12
RE	MCC-112	141216	Coaxial cable	Fujikura/Suhner/TSJ	5D-2W/SFM14/sucoform141-PE/421-010/RFM-E321(SW)	-/00640	07/19/2021	12
RE	LP-01	146966	Loop Antenna	Rohde & Schwarz	HFH2-Z2	829425/014	01/19/2021	12

*Hyphens for Last Calibration Date and Cal Int (month) are instruments that Calibration is not required (e.g. software), or instruments checked in advance before use.

The expiration date of the calibration is the end of the expired month.

As for some calibrations performed after the tested dates, those test equipment have been controlled by means of an unbroken chains of calibrations.

All equipment is calibrated with valid calibrations. Each measurement data is traceable to the national or international standards.

Test item: RE: Radiated Emission

UL Japan, Inc.

Ise EMC Lab.

4383-326 Asama-cho, Ise-shi, Mie-ken 516-0021 JAPAN

Telephone : +81 596 24 8999

Facsimile : +81 596 24 8124

Test equipment (Tested on January 30, 2022)

Test Item	Local ID	LIMS ID	Description	Manufacturer	Model	Serial	Last Calibration Date	Cal Int
RE	MAEC-04	142011	AC4_Semi Anechoic Chamber(NSA)	TDK	Semi Anechoic Chamber 3m	DA-10005	05/25/2020	24
RE	MOS-15	141562	Thermo-Hygrometer	CUSTOM. Inc	CTH-201	0010	01/10/2022	12
RE	MMM-10	141545	DIGITAL HiTESTER	HIOKI E.E. CORPORATION	3805	51201148	01/07/2021	12
RE	MJM-29	142230	Measure	KOMELON	KMC-36	-	-	-
RE	COTS-MEMI-02	178648	EMI measurement program	TSJ (Techno Science Japan)	TEPTO-DV	-	-	-
RE	MAT-34	141331	Attenuator(6dB)	TME	UFA-01	-	02/02/2021	12
RE	MBA-05	141425	Biconical Antenna	Schwarzbeck Mess-Elektronik OHG	VHA9103+BBA9106	VHA 91031302	08/28/2021	12
RE	MCC-50	141397	Coaxial Cable	UL Japan	-	-	11/03/2021	12
RE	MLA-23	141267	Logperiodic Antenna (200-1000MHz)	Schwarzbeck Mess-Elektronik OHG	VUSLP9111B	9111B-192	08/28/2021	12
RE	MPA-14	141583	Pre Amplifier	SONOMA INSTRUMENT	310	260833	02/18/2021	12
RE	MTR-03	141942	Test Receiver	Rohde & Schwarz	ESCI	100300	08/05/2021	12
RE	MCC-113	141217	Coaxial cable	Fujikura/Suhner/TSJ	5D-2W/SFM141/421-010/sucoform141-PE/RFM-E121(SW)	-/04178	06/02/2021	12
RE	MLPA-01	141254	Loop Antenna	Rohde & Schwarz	HFH2-Z2	100017	04/17/2021	12
RE	MCC-255	207745	Coaxial Cable	UL Japan Inc.	-	-	05/17/2021	12
RE	MPA-13	141582	Pre Amplifier	SONOMA INSTRUMENT	310	260834	02/18/2021	12
RE	MSA-14	141901	Spectrum Analyzer	Keysight Technologies Inc	E4440A	MY48250080	01/10/2022	12

*Hyphens for Last Calibration Date and Cal Int (month) are instruments that Calibration is not required (e.g. software), or instruments checked in advance before use.

The expiration date of the calibration is the end of the expired month.

As for some calibrations performed after the tested dates, those test equipment have been controlled by means of an unbroken chains of calibrations.

All equipment is calibrated with valid calibrations. Each measurement data is traceable to the national or international standards.

Test item: RE: Radiated Emission

UL Japan, Inc.

Ise EMC Lab.

4383-326 Asama-cho, Ise-shi, Mie-ken 516-0021 JAPAN

Telephone : +81 596 24 8999

Facsimile : +81 596 24 8124