



**SENSORWORX®**

# WIRELESS WIDEVIEW & HALLWAY OCCUPANCY SENSORS

## INSTALLATION & OPERATION INSTRUCTIONS

MODEL NUMBERS	DESCRIPTION
SWX-401-B	WIRELESS WIDEVIEW SENSOR, PIR, BATTERY POWERED
SWX-402-B	WIRELESS HALLWAY SENSOR, PIR, BATTERY POWERED

## OVERVIEW

The **SENSORWORX®** wireless wide view and hallway occupancy sensors are a simple, yet reliable battery powered control solution. Preferred by contractors for their flexible mounting methods, **SENSORWORX** wireless sensors greatly reduce total installation time and wireless pairing fuss. Requiring just a few seconds per device, **SENSORWORX** wireless sensors can be linked to one or more wireless load controllers (such as the **SWX-851** wireless wall switch, or a **SWX-950** series wireless power pack). Additionally, these sensors can be configured to work in applications with other wireless or wired ceiling, corner, or hallway sensors to provide extended coverage in large or irregularly shaped spaces. As with all **SENSORWORX** products, the latest passive infrared technology and digital signal processing techniques are used to provide unmatched occupant detection performance and energy savings.

## BASIC OPERATION

Sensors detect movement in the infrared energy that radiates from occupants as they move within the device's field-of-view. Once occupancy is detected, the sensor immediately signals a wirelessly linked load controller (e.g. power pack) to switch on or dim up the connected lighting. At regular intervals, the sensor will retransmit its latest occupancy status such that the load controller can keep lights on for occupants during brief periods of inactivity, while returning the space to an energy saving lights off (or dim) state once no longer occupied.

## FEATURES

- Pairs in Seconds with Wireless Controllers
- Passive Infrared (PIR) Detection
- Wide View or Hallway (Long Range) Coverage Pattern Options
- 10 Year Battery Life Design
- Compact Size and Matte Finish
- Five Contractor Friendly Mounting Methods
- Mounting Nipple Attachment with Integrated Hole Saw
- Convenient Test Modes

## SPECIFICATIONS

### ELECTRICAL & WIRELESS

**BATTERY TYPE**  
Requires one CR123(A) Lithium Battery

**BATTERY LIFE**  
Designed for 10 Year Life (under default settings)  
Non-Volatile Memory (saves all settings regardless of battery state)  
Blink Warning @10% Life

**RANGE**  
80' line of site w/o obstruction (walls)  
40' with obstruction (walls/floors)

**FREQUENCY**  
915 MHz ISM Band

**WIRELESS LINKING**  
Simple 3 sec. Push Button Process

**SECURITY**  
All Wireless Data is Encrypted

### ENVIRONMENTAL

**OPERATING TEMP**  
32°F to 122°F (0°C to 50°C)

**RELATIVE HUMIDITY**  
0-95% Non-Condensing,  
Indoor Use Only

### CODE COMPLIANCE

These sensors can be used to meet ASHRAE 90.1, IECC, & Title 24 energy code requirements.

### PHYSICAL

**SIZE**  
2.875" H x 2.75" W x 3.25"D  
(7.30 x 6.98 x 8.25 cm)

**WEIGHT**  
4.75 oz.

**COLOR**  
White

**LED INDICATION**  
Motion Detection (when in Test Mode)  
Wireless Linking (Pairing)

### OPERATION

**OPERATING MODES**  
Occupancy & Vacancy Modes  
Configured on Linked Controller

**COMPATIBLE LOAD CONTROLLERS**  
SWX-851 Wall Switch  
SWX-950 Series Power Packs

**WIRELESS TEST MODE**  
Button Toggles On/Off  
Wirelessly Linked Loads

**COVERAGE TEST MODE**  
White LED Illuminates Upon Detected Occupancy

**TIME DELAY OPTIONS**  
Configured at Load Controller(s)  
1, 5, 10, 15, 20, 30 min.



## DETAILED OPERATION

- By default, every ~60 seconds the sensor transmits whether or not occupancy was detected during the previous period.
- Referred to as the sensor's "heartbeat", this period can be reduced to ~30 seconds although this will decrease expected battery life.
- If a sensor transmitted "unoccupied" at its last heartbeat, any new occupancy detection event will be transmitted immediately.
- If a sensor transmitted "occupied" at its last heartbeat, new occupancy events will only be transmitted at the heartbeat interval, thus conserving battery life.
- The wirelessly linked wall switch load controller and/or power pack maintains a master time delay that is reset every time a linked sensor reports occupancy. Lights will be switched off once all linked sensors have continuously reported unoccupied for the duration of the time delay.

# COVERAGE PATTERN

## PASSIVE INFRARED (PIR)

### WIDE VIEW 120°

- Small motion (e.g., hand movements) detection up to 40 ft (12.19 m)
- Large motion (e.g., walking) detection up to 70 ft (21.34 m)
- Designed for 8 to 12 ft (2.44 to 3.66 m) high mounting

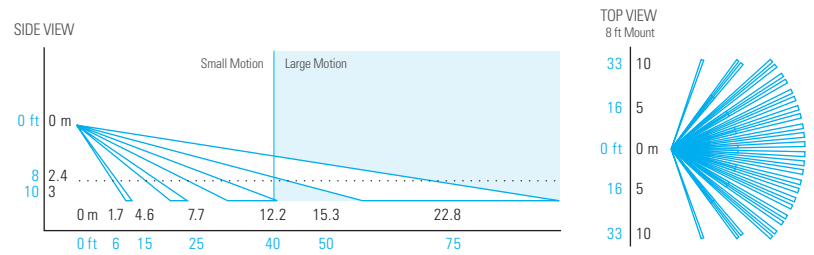
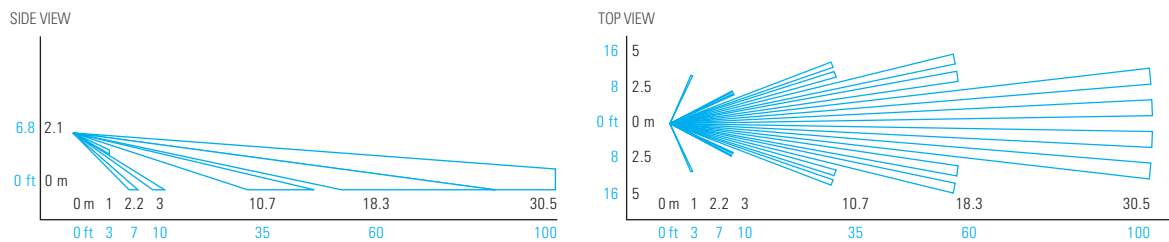

Diagram reflects sensor in first position. Adjust angle downward if mounting above 10 feet or to decrease gap directly under sensor.

### HALLWAY (LONG RANGE)

- Designed for 8 to 12 ft (2.44 to 3.66 m) high mounting
- Large motion (e.g., walking) detection up to 100 ft (30.48 m)
- Detection occurs sooner when crossing coverage beams upon entry to a hallway as opposed to entering from the end and walking directly at the sensor



# APPLICATIONS

A single wireless wide view sensor provides an excellent solution for a medium sized space like a conference room or small classroom. However, multiple wireless sensors can be easily linked to the same load controller(s) to provide coverage for larger spaces like an open office or large classroom. The wireless hallway sensor provides excellent coverage of hallways from one or both ends. Additionally, when linked to wireless wall switch load controllers (**SWX-851**) or to wireless power packs (**SWX-950** Series) and remote wireless wall stations, these sensors can be used to meet ASHRAE 90.1, IECC, & Title 24 energy code requirements that require vacancy operation.

- Classrooms
- Open Offices
- Conference Rooms
- Hallways
- Break Rooms

## COMPATIBLE WIRELESS DEVICES

The below chart lists the devices that can be used in a **SENSORWORX** wireless application. Note that sensors and remote switch & dimmer devices are transmit only devices and therefore must be linked to a load controller for switching or dimming of lighting.

MODEL #	DESCRIPTION	WIRELESS TYPE	POWER TYPE
SWX-201-B	Small Motion 360° Sensor, PIR	Transmit	Battery
SWX-401-B	Wide View Sensor, PIR	Transmit	Battery
SWX-402-B	Long Range Hallway Sensor, PIR	Transmit	Battery
SWX-851-xx	Wall Switch Load Controller, No Neutral Required, <xx = color>	Transmit & Receive	120-277 VAC
SWX-852-B-xx	Remote Switch (On/Off), <xx = color>	Transmit	Battery
SWX-854-B-xx	Remote Dimming Switch (On/Off, Raise/Lower), <xx = color>	Transmit	Battery
SWX-950	Power Pack Load Controller, 20A	Receive	120/277 VAC
SWX-950-D2	Power Pack Load Controller, 20A, 0-10V Dimming	Receive	120/277 VAC
SWX-950-AX	Hybrid Wireless/Wired Power Pack Load Controller, 20A	Transmit & Receive	120/277 VAC
SWX-950-AX-D2	Hybrid Wireless/Wired Power Pack Load Controller, 20A, 0-10V Dimming	Transmit & Receive	120/277 VAC

# BATTERY INFORMATION

- The sensor runs on one CR123(A) Lithium Battery (included).
- Install battery prior to mounting sensor. Polarity is indicated on the battery compartment door.
- If the sensor's battery life reaches 10%, all wirelessly linked load controllers will blink lights on/off/on upon initial occupancy as a replacement warning.
- Replacement batteries are available at most retailers or home centers where batteries are sold or from **SENSORWORX**.

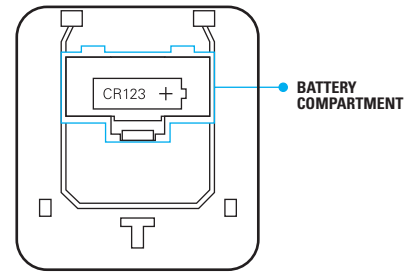

# INSTALLATION OPTIONS

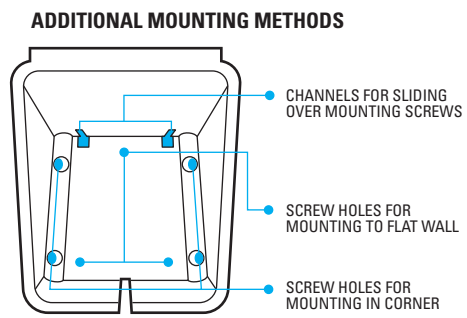
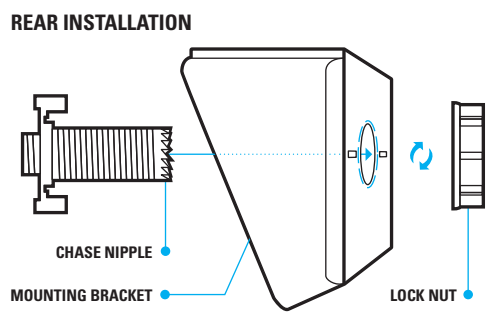
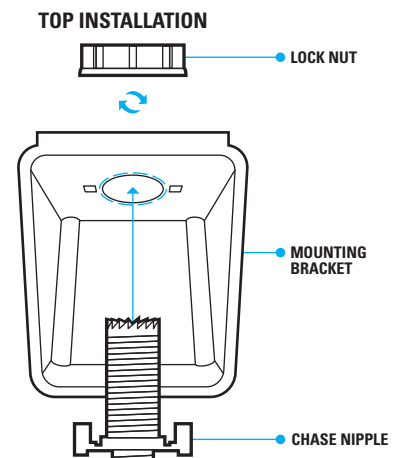
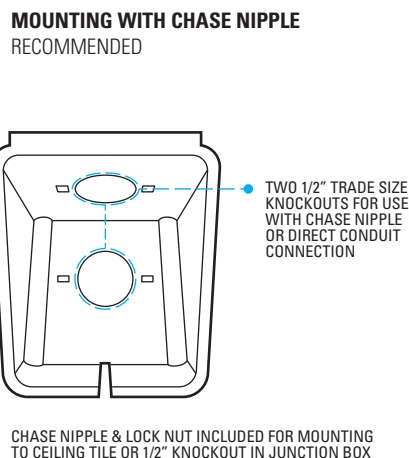
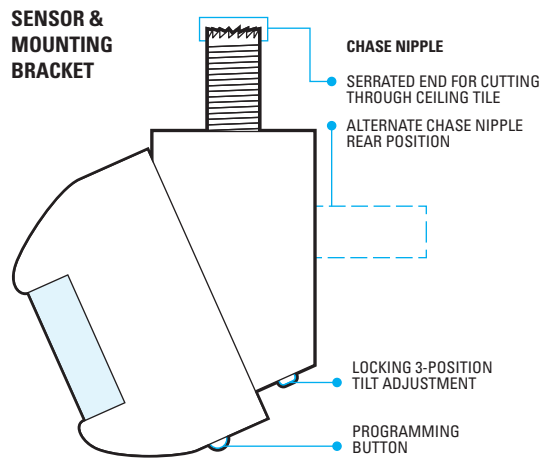

# WIRELESS LINKING (PAIRING)

Linking a sensor with a wireless load controller is quickly done via the following procedure:

- Step 1.** Enter pairing mode by holding down the wireless load controller button for 3 seconds until the LED starts alternating white then blue, then release.
- Step 2.** At the sensor, hold down the programming button for 3 seconds until the LED starts alternating white then blue. Releasing will link the sensor with any device in pairing mode (see note 1 below). The lights will toggle once as confirmation.
- Step 3.** Repeat step 2 to link another sensor or device.
- Step 4.** When all devices have been linked, exit pairing mode on the wireless load controller by pressing the button 1 time. Pairing will also be automatically closed after 15 minutes of no new devices being linked.

**Note 1:** When in pairing mode, the alternating LED colors on the wireless load controller will periodically pause and blink out the total number of linked devices. There will be no blinks during the pause until the first device is linked.

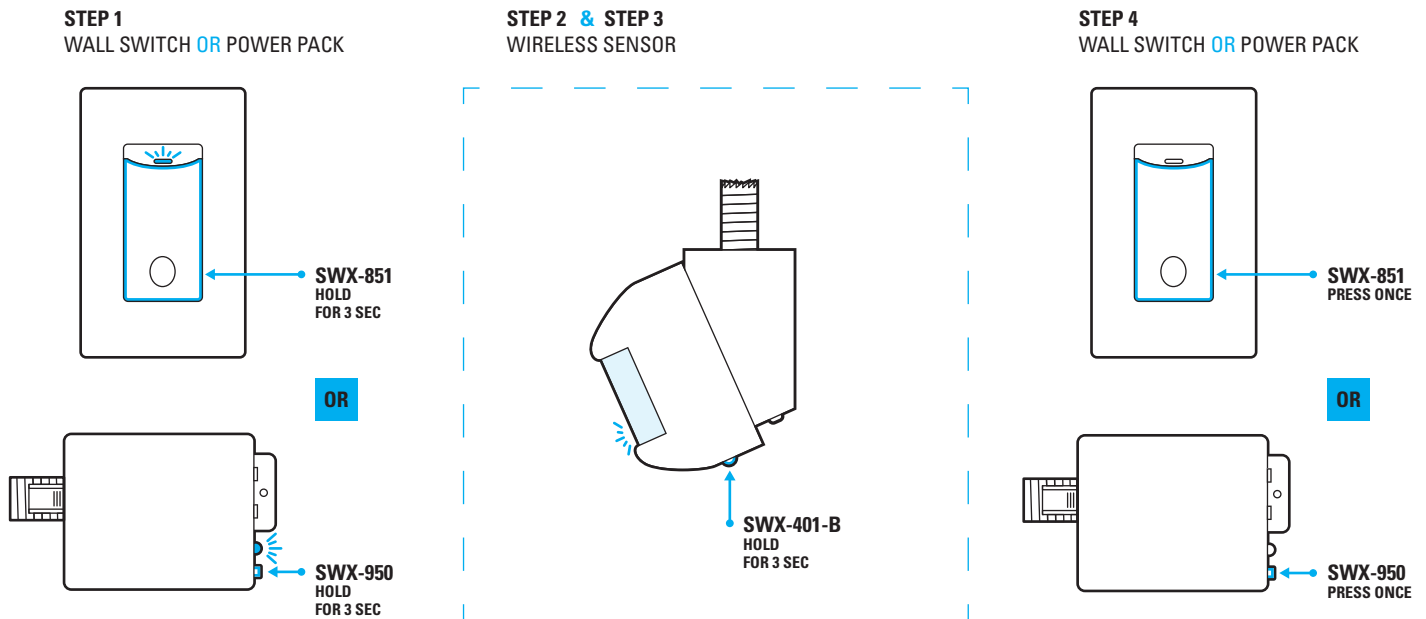

# CONFIGURATION

## SENSOR HEARTBEAT TIME

The period between transmissions of a wireless sensor is referred to as the sensor's "heartbeat". For best battery life performance, it is recommended that the default heartbeat time of 1 minute be used. However, if a linked load controller is using the 30 second time delay option, the sensor's heartbeat needs to also be changed to 30 seconds. Note that doing so will decrease battery life.

SETTING #	DESCRIPTION
2	30 Seconds
3	1 Minute (Default)

## CHANGING THE HEARTBEAT TIME

- 1** Read through the above list and note the number of the desired setting (e.g. 2 = 30 secs.)
- 2** Press and release the unit's pushbutton **3 times**, then wait 2 seconds. The White LED will blink back the number of the current setting (repeats 3x before exiting).
- 3** Interrupt blink back by pressing the button the number times equal to the new desired setting (e.g. 2 = 30 secs).
- 4** The LED will blink back the new setting number as confirmation and will be saved after three confirmations. After the third confirmation sequence, a successful save will be indicated by two sets of rapid White flashes. If the Blue LED rapid flashes twice, save was unsuccessful and process should be started over.

# TESTING & TROUBLESHOOTING

## COVERAGE TEST MODE

To put a sensor in **COVERAGE** test mode for 10 minutes:

1. Press and release the button **two times**.
2. Once the LED blinks white, press and release the button **one** additional time.
3. The LED will blink back white three times and then rapid flash twice indicating the change to test mode was successful.

To test coverage, wait until lights turn off then walk into range of sensor. While in test mode the LED will blink when it transmits an occupied signal (maximum of once every 4 seconds). After 10 minutes, the unit will automatically exit test mode.

**Note:** Once test mode has been initiated from a linked sensor, the linked controller will ignore all other sensors until a new sensor initiates test mode or the 10 minutes expires.

## TESTING WIRELESS LINKING (PAIRING)

1. Press and release the button one time.

Lighting controlled by any/all linked load controller(s) will toggle one time as confirmation.

## RESTORING FACTORY DEFAULTS / UNPAIRING

To return a wireless sensor to its original factory default settings or to unpair from all linked wireless load controllers the following commands can be executed.

SETTING #	DESCRIPTION
3	Restore Factory Defaults
4	Send a "Forget Me" Message to all Paired Controllers

### ENTERING A RESTORE FACTORY DEFAULTS OR FORGET ME COMMAND

- 1 Read through the above list and note the number of the desired command
- 2 Press and release the unit's pushbutton **8 times**, then wait 2 seconds. The White LED will blink back 2 times, pause and repeat.
- 3 Interrupt the blink back and press the pushbutton the number times equal to the desired command (e.g. 3 times to Restore Factory Defaults).
- 4 The LED will flash back the command number as confirmation and will be executed after three confirmations. Two sets of rapid White flashes indicates success. If the Blue LED rapid flashes twice, the command was unsuccessful and process should be started over.

## FCC INFORMATION (FCC ID: 2AVRY-SWX0002)

This device complies with Part 15 of the FCC Rules. Operation is subject to the following conditions:

1. This device may not cause harmful interference, and
2. This device must accept any interference received, including interference that may cause undesired operation

Changes and Modifications not expressly approved by BLP Technologies can void your authority to operate this equipment under Federal Communications Commission's rules.

In order to comply with FCC/ISED RF Exposure requirements, this device must be installed to provide at least 20 cm separation from the human body at all times.

This equipment has been tested and found to comply with the limits for a Class B digital device, pursuant to Part 15 of the FCC Rules. These limits are designed to provide reasonable protection against harmful interference in a residential installation. This equipment generates uses and can radiate radio frequency energy and, if not installed and used in accordance with the instructions, may cause harmful interference to radio communications. However, there is no guarantee that interference will not occur in a particular installation. If this equipment does cause harmful interference to radio or television reception, which can be determined by turning the equipment off and on, the user is encouraged to try to correct the interference by one of the following measures:

- Reorient or relocate the receiving antenna.
- Increase the separation between the equipment and receiver.
- Connect the equipment into an outlet on a circuit different from that to which the receiver is connected.
- Consult the dealer or an experienced radio/TV technician for help

## ISED CANADA INFORMATION (IC: 26012-SWX0002)

This device contains licence-exempt transmitter(s)/receiver(s) that comply with Innovation, Science and Economic Development Canada's licence-exempt RSS(s). Operation is subject to the following two conditions:

1. This device may not cause interference.
2. This device must accept any interference, including interference that may cause undesired operation of the device.

In order to comply with FCC/ISED RF Exposure requirements, this device must be installed to provide at least 20 cm separation from the human body at all times.

L'émetteur/récepteur exempt de licence contenu dans le présent appareil est conforme aux CNR d'Innovation, Sciences et Développement économique Canada applicables aux appareils radio exempts de licence. L'exploitation est autorisée aux deux conditions suivantes :

1. L'appareil ne doit pas produire de brouillage;
2. L'appareil doit accepter tout brouillage radioélectrique subi, même si le brouillage est susceptible d'en compromettre le fonctionnement.
3. Afin de se conformer aux exigences d'exposition RF FCC / ISED, cet appareil doit être installé pour fournir au moins 20 cm de séparation du corps humain en tout temps

